

JRC SCIENCE FOR POLICY REPORT

Best Available Techniques (BAT) Reference Document for the Food, Drink and Milk Industries

*Industrial Emissions Directive
2010/75/EU
(Integrated Pollution
Prevention and Control)*

Germán Giner Santonja, Panagiotis Karlis,
Kristine Raunkjær Stubdrup,
Serge Roudier

2019



Best Available Techniques (BAT) Reference Document for the Food, Drink and Milk Industries

Industrial Emissions Directive 2010/75/EU
Integrated Pollution Prevention and Control

Authors:

Germán GINER SANTONJA
Panagiotis KARLIS
Kristine Raunkjær STUBDRUP
Serge ROUDIER

2019

EUR 29978 EN

This publication is a Science for Policy report by the Joint Research Centre, the European Commission's in-house science service. It aims to provide evidence-based scientific support to the European policy-making process. The scientific output expressed does not imply a policy position of the European Commission. Neither the European Commission nor any person acting on behalf of the Commission is responsible for the use which might be made of this publication.

Contact information

Name: European IPPC Bureau

Address: Joint Research Centre, Edificio Expo c/ Inca Garcilaso 3, E-41092 Seville, Spain

E-mail: JRC-B5-EIPPCB@ec.europa.eu

Tel.: +34 95 4488 284

JRC Science Hub

<https://ec.europa.eu/jrc>

Legal Notice

Under the Commission Decision of 12 December 2011 on the Re-use of Commission Documents (2011/833/EU), the present BREF document is subject to free re-use, except for parts covered by any third-party rights which may be present in the document (such as images, tables, data, written material, or similar, the rights to which need to be acquired separately from their respective rights-holders for further use). The European Commission is not liable for any consequence stemming from the re-use of this publication. Any re-use is subject to the acknowledgement of the source and non-distortion of the original meaning or message.

JRC118627

EUR 29978 EN

PDF ISBN 978-92-76-13091-8 ISSN 1831-9424 doi:10.2760/243911

Luxembourg: Publications Office of the European Union, 2019.

© European Union, 2019

How to cite this report: Germán Giner Santonja, Panagiotis Karlis, Kristine Raunkjær Stubdrup, Serge Roudier; *Best Available Techniques (BAT) Reference Document for the Food, Drink and Milk Industries*; EUR 29978 EN; doi:10.2760/243911.

All images © European Union 2019, except: Cover picture credits in clockwise order starting from the left: 1. Tanks © FoodDrinkEurope; 2.stockphoto © fotolia.com - stockphoto-graf; 3. Food industry. Shop equipment © fotolia.com - Buhanovskiy.com.ua.

Title

Best Available Techniques (BAT) Reference Document for the Food, Drink and Milk Industries

Abstract

The Best Available Techniques (BAT) Reference Document (BREF) for the Food, Drink and Milk Industries is part of a series of documents presenting the results of an exchange of information between EU Member States, the industries concerned, non-governmental organisations promoting environmental protection, and the Commission, to draw up, review and – where necessary – update BAT reference documents as required by Article 13(1) of Directive 2010/75/EU on Industrial Emissions (the Directive). This document is published by the European Commission pursuant to Article 13(6) of the Directive.

The BREF for the Food, Drink and Milk Industries covers the treatment and processing, other than exclusively packaging, of the animal and/or vegetable raw materials, whether previously processed or unprocessed, intended for the production of food or feed, as specified in Section 6.4 (b) of Annex I to Directive 2010/75/EU.

Important issues for the implementation of Directive 2010/75/EU in the food, drink and milk (FDM) sector are emissions to water, energy and water consumption. Chapter 1 provides general information on the FDM sector and on the industrial processes and techniques used within this sector. Chapter 2 provides information on the common industrial processes, abatement systems and general techniques that are used across the FDM sector. General techniques to consider in the determination of BAT (i.e. those techniques to consider that are widely applied in the FDM sector) are reported in Chapter 2. Chapters 3 to 15 give the applied processes, current emission and consumption levels, techniques to consider in the determination of BAT and emerging techniques for the FDM sectors that are covered by these chapters. Chapter 16 provides thumbnail descriptions of additional FDM sectors, for which a data collection via questionnaires has not been carried out. Chapter 17 presents the BAT conclusions as defined in Article 3(12) of the Directive, both general and sector-specific. Concluding remarks and recommendations for future work are presented in Chapter 18.

Acknowledgements

This report was produced by the European Integrated Pollution Prevention and Control Bureau (EIPPCB) at the European Commission's Joint Research Centre – Directorate B: Growth and Innovation under the supervision of Serge Roudier (Head of the EIPPCB) and Luis Delgado Sancho (Head of the Circular Economy and Industrial Leadership Unit).

The authors of this BREF were Germán Giner Santonja, Panagiotis Karlis and Kristine Raunkjær Stubdrup.

This report was drawn up in the framework of the implementation of the Industrial Emissions Directive (2010/75/EU) and is the result of the exchange of information provided for in Article 13 of the Directive.

Major contributors of information were:

- among EU Member States: Austria, Belgium, Denmark, Finland, France, Germany, Ireland, Italy, the Netherlands, Poland, Portugal, Spain, Sweden and the United Kingdom;
- among industry: CEFS (European Association of Sugar Manufacturers), CLITRAVI (Liaison Centre for the Meat Processing Industry in the European Union), COPA-COGECA (Committee of Professional Agricultural Organisations and General Committee for Agricultural Cooperation in the European Union), EDA (European Dairy Association), FEDIAF (European Pet Food Industry), FEDIOL (The EU Vegetable Oil and Proteinmeal Industry Association), FEFAC (European Feed Manufacturers' Federation), FoodDrinkEurope, Starch Europe and The Brewers of Europe;
- among environmental Non-Governmental Organisations: EEB (European Environmental Bureau).

Other contributors to the review process were Croatia, Czechia, Romania, Slovakia, Slovenia, ADEPALE (Association Des Entreprises de Produits ALimentaires Élaborés), ANIA (French Food and Drink Association), ATLA (French Association of Dairy Processors), AVEC (Association of Poultry Processors and Poultry Trade in the EU countries), EPURE (European Renewable Ethanol), European Coffee Federation, EUPPA (European Potato Processors' Association), EUROMALT and SNFS (French Sugar Manufacturers Association).

The whole EIPPCB team provided contributions and peer reviewing.

This report was edited by Anna Atkinson and formatted by Carmen Ramírez Martín.

This document is one of a series of foreseen documents listed below:

Reference Document on Best Available Techniques (BREF)	Code
Ceramic Manufacturing Industry	CER
Common Waste Water and Waste Gas Treatment/Management Systems in the Chemical Sector	CWW
Common Waste Gas Management and Treatment Systems in the Chemical Sector	WGC
Emissions from Storage	EFS
Energy Efficiency	ENE
Ferrous Metals Processing Industry	FMP
<i>Food, Drink and Milk Industries</i>	<i>FDM</i>
Industrial Cooling Systems	ICS
Intensive Rearing of Poultry or Pigs	IRPP
Iron and Steel Production	IS
Large Combustion Plants	LCP
Large Volume Inorganic Chemicals – Ammonia, Acids and Fertilisers Industries	LVIC-AAF
Large Volume Inorganic Chemicals – Solids and Others Industry	LVIC-S
Large Volume Organic Chemical Industry	LVOC
Management of Tailings and Waste-rock in Mining Activities	MTWR
Manufacture of Glass	GLS
Manufacture of Organic Fine Chemicals	OFC
Non-ferrous Metals Industries	NFM
Production of Cement, Lime and Magnesium Oxide	CLM
Production of Chlor-alkali	CAK
Production of Polymers	POL
Production of Pulp, Paper and Board	PP
Production of Speciality Inorganic Chemicals	SIC
Production of Wood-based Panels	WBP
Refining of Mineral Oil and Gas	REF
Slaughterhouses and Animals By-products Industries	SA
Smitheries and Foundries Industry	SF
Surface Treatment of Metals and Plastics	STM
Surface Treatment Using Organic Solvents including Wood and Wood Products Preservation with Chemicals	STS
Tanning of Hides and Skins	TAN
Textiles Industry	TXT
Waste Incineration	WI
Waste Treatment	WT
Reference Document (REF)	
Economics and Cross-media Effects	ECM
Monitoring of Emissions to Air and Water from IED Installations	ROM

Electronic versions of draft and finalised documents are publicly available and can be downloaded from <http://eippcb.jrc.ec.europa.eu>.

PREFACE

1. Status of this document

Unless otherwise stated, references to ‘the Directive’ in this document refer to Directive 2010/75/EU of the European Parliament and the Council on industrial emissions (integrated pollution prevention and control) (Recast).

The original best available techniques (BAT) reference document (BREF) on Food, Drink and Milk Industries was adopted by the European Commission in 2006. This document is the result of a review of that BREF. The review commenced in December 2013.

This BAT reference document for the Food, Drink and Milk Industries forms part of a series presenting the results of an exchange of information between EU Member States, the industries concerned, non-governmental organisations promoting environmental protection and the Commission, to draw up, review, and where necessary, update BAT reference documents as required by Article 13(1) of the Directive. This document is published by the European Commission pursuant to Article 13(6) of the Directive.

As set out in Article 13(5) of the Directive, the Commission Implementing Decision (EU) 2019/2031 on the BAT conclusions contained in Chapter 17 was adopted on 12 November 2019 and published on 4 December 2019¹.

2. Participants in the information exchange

As required in Article 13(3) of the Directive, the Commission has established a forum to promote the exchange of information, which is composed of representatives from Member States, the industries concerned and non-governmental organisations promoting environmental protection (Commission Decision of 16 May 2011 establishing a forum for the exchange of information pursuant to Article 13 of the Directive 2010/75/EU on industrial emissions (2011/C 146/03), OJ C 146, 17.05.2011, p. 3).

Forum members have nominated technical experts constituting the technical working group (TWG) that was the main source of information for drafting this document. The work of the TWG was led by the European IPPC Bureau (of the Commission’s Joint Research Centre).

3. Structure and contents of this document

Chapter 1 provides general information on the food, drink and milk (FDM) sector and on the industrial processes and techniques used within this sector.

Chapter 2 provides information on the common industrial processes, abatement systems and general techniques that are used across the sector. General techniques to consider in the determination of BAT (i.e. those techniques to consider that are widely applied in this sector) are reported in Chapter 2. Chapters 3 to 15 give the applied processes, current emission and consumption levels, techniques to consider in the determination of BAT and emerging techniques for the FDM sectors that are covered by these chapters. Chapter 16 provides thumbnail descriptions of additional FDM sectors, for which a data collection via questionnaires has not been carried out. Chapter 17 presents the BAT conclusions as defined in Article 3(12) of the Directive, both general and sector-specific.

¹ [OJ L 313, 4.12.2019, p. 60.](#)

Chapters 3 to 15 provide the information given below on specific FDM sectors (i.e. animal feed, brewing, dairies, ethanol production, fish and shellfish processing, fruit and vegetables, grain milling, meat processing, oilseed processing and vegetable oil refining, olive oil processing and refining, soft drinks and nectar/juice, starch production, sugar manufacturing). For each FDM sector, the chapter is structured as follows (*X* is the chapter number):

- Section X.1 provides general information on the FDM sector.
- Section X.2 provides information on applied processes and techniques.
- Section X.3 provides data and information concerning the environmental performance of installations within the sector, and in operation at the time of writing, in terms of current emissions, consumption and nature of raw materials, and use of energy.
- Section X.4 describes in more detail the techniques to prevent or, where this is not practicable, to reduce the environmental impact of operating installations in this sector that were considered in determining the BAT. This information includes, where relevant, the environmental performance levels (e.g. emission and consumption levels) which can be achieved by using the techniques, the associated monitoring, the costs and the cross-media issues associated with the techniques.
- Section X.5 presents information on emerging techniques as defined in Article 3(14) of the Directive.

Concluding remarks and recommendations for future work are presented in Chapter 18.

4. Information sources and the derivation of BAT

This document is based on information collected from a number of sources, in particular through the TWG that was established specifically for the exchange of information under Article 13 of the Directive. The information has been collated and assessed by the European IPPC Bureau (of the Commission's Joint Research Centre) who led the work on determining BAT, guided by the principles of technical expertise, transparency and neutrality. The work of the TWG and all other contributors is gratefully acknowledged.

The BAT conclusions have been established through an iterative process involving the following steps:

- identification of the key environmental issues for the Food, Drink and Milk Industries;
- examination of the techniques most relevant to address these key issues;
- identification of the best environmental performance levels, on the basis of the available data in the European Union and worldwide;
- examination of the conditions under which these environmental performance levels were achieved, such as costs, cross-media effects, and the main driving forces involved in the implementation of the techniques;
- selection of the best available techniques (BAT), their associated emission levels (and other environmental performance levels) and the associated monitoring for this sector according to Article 3(10) of, and Annex III to, the Directive.

Expert judgement by the European IPPC Bureau and the TWG has played a key role in each of these steps and the way in which the information is presented here.

Where available, economic data have been given together with the descriptions of the techniques presented in *Techniques to consider in the determination of BAT* sections. These data give a rough indication of the magnitude of the costs and benefits. However, the actual costs and benefits of applying a technique may depend strongly on the specific situation of the installation concerned, which cannot be evaluated fully in this document. In the absence of data concerning costs, conclusions on the economic viability of techniques are drawn from observations on existing installations.

5. Review of BAT reference documents (BREFs)

BAT is a dynamic concept and so the review of BREFs is a continuing process. For example, new measures and techniques may emerge, science and technologies are continuously developing and new or emerging processes are being successfully introduced into the industries. In order to reflect such changes and their consequences for BAT, this document will be periodically reviewed and, if necessary, updated accordingly.

6. Contact information

All comments and suggestions should be made to the European IPPC Bureau at the Joint Research Centre (JRC) at the following address:

European Commission
JRC Directorate B - Growth and Innovation
European IPPC Bureau
Edificio Expo
c/ Inca Garcilaso, 3
E-41092 Seville, Spain
Telephone: +34 95 4488 284
E-mail: JRC-B5-EIPPCB@ec.europa.eu
Internet: <http://eippcb.jrc.ec.europa.eu>

**Best Available Techniques Reference Document for
Food, Drink and Milk Industries**

PREFACE	I
SCOPE	XXXIII
1 GENERAL INFORMATION ABOUT THE FDM SECTOR	1
1.1 DESCRIPTION, TURNOVER, GROWTH, EMPLOYMENT	1
1.2 SECTOR STRUCTURE	3
1.3 TRADE.....	5
1.4 MARKET FORCES: DEMAND, DISTRIBUTION AND COMPETITION	7
1.4.1 Demand	7
1.4.2 Distribution	7
1.4.3 Competition.....	7
1.5 THE IMPORTANCE OF FOOD SAFETY IN FDM PROCESSING	8
1.6 LEGISLATIVE FRAMEWORK FOR FOOD, DRINK AND MILK PRODUCTS.....	9
1.7 THE FDM SECTOR AND THE ENVIRONMENT.....	10
1.7.1 Key environmental issues.....	11
2 GENERAL PROCESSES AND TECHNIQUES ACROSS THE FDM SECTOR	13
2.1 APPLIED PROCESSES AND TECHNIQUES ACROSS THE FDM SECTOR.....	13
2.1.1 Introduction	13
2.1.2 Energy consumption.....	14
2.1.2.1 General processing techniques	15
2.1.2.1.1 Combined heat and power generation	15
2.1.2.1.2 Heat pumps for heat recovery.....	15
2.1.2.1.3 Use of permanent magnet synchronous motors.....	16
2.1.2.1.4 Electrical power supply	16
2.1.2.2 Techniques related to cooling/freezing	16
2.1.2.2.1 Heat recovery from cooling systems	18
2.1.2.2.2 Use of high-efficiency motors for driving fans	18
2.1.2.2.3 Dynamic cooling condensation control	18
2.1.2.3 Techniques related to compressed air systems	18
2.1.2.3.1 Optimisation of the air inlet temperature.....	18
2.1.3 Water consumption	19
2.1.3.1 Types of water consumption	20
2.1.3.1.1 Process water.....	20
2.1.3.1.2 Cooling water	21
2.1.3.1.3 Boiler feed water	21
2.1.3.1.4 Water recycling and reuse	21
2.1.3.2 Cleaning and disinfection.....	22
2.1.3.2.1 Selection of cleaning agents	23
2.1.3.2.2 Sinner's circle.....	26
2.1.4 Solid output	26
2.1.4.1 Packaging.....	27
2.1.5 Waste water treatment.....	29
2.1.5.1 Introduction.....	29
2.1.5.2 Waste water discharge.....	30
2.1.5.2.1 Waste water landspreading	31
2.1.5.3 Waste water treatment techniques.....	32
2.1.5.3.1 Introduction	32
2.1.5.3.2 Primary treatment.....	34

2.1.5.3.3	Secondary treatment	34
2.1.5.3.4	Tertiary treatment	37
2.1.5.3.5	Natural treatment	37
2.1.5.3.6	Sludge treatment	38
2.1.6	Treatment of emissions to air.....	38
2.1.6.1	Process-integrated techniques	39
2.1.6.2	Treatment techniques for emissions to air	39
2.1.6.2.1	Dynamic separation techniques	41
2.1.6.2.2	Filters	41
2.1.6.2.3	Absorption	42
2.1.6.2.4	Biological treatment.....	45
2.1.6.2.5	Thermal treatment of waste gases.....	45
2.1.6.3	Odour.....	46
2.1.6.4	Emissions to air control strategy.....	47
2.1.6.4.1	Step 1: Definition of the problem	49
2.1.6.4.2	Step 2: Inventory of site emissions	49
2.1.6.4.3	Step 3: Measurement of major emissions	51
2.1.6.4.4	Step 4: Selection of air emission control techniques.....	52
2.1.7	Accidental release	54
2.2	CURRENT CONSUMPTION AND EMISSION LEVELS ACROSS THE FDM SECTOR	55
2.2.1	Energy consumption	55
2.2.2	Water consumption	55
2.2.3	Waste water discharge	56
2.3	TECHNIQUES TO CONSIDER IN THE DETERMINATION OF BAT ACROSS THE FDM SECTOR	67
2.3.1	General environmental performance.....	68
2.3.1.1	Environmental management systems.....	68
2.3.1.2	Integrated monitoring system	71
2.3.1.3	Temperature control by dedicated measurement and correction	72
2.3.1.4	Level measurement.....	73
2.3.1.5	Conductivity measurement	74
2.3.1.6	Turbidity measurement.....	77
2.3.1.7	Consumption and stream inventory/register	78
2.3.2	Techniques to increase energy efficiency	79
2.3.2.1	General processing techniques.....	79
2.3.2.1.1	Heat recovery.....	79
2.3.2.1.2	Use of the biogas generated	81
2.3.2.1.3	Process control systems	82
2.3.2.1.4	Combined heat and power generation.....	83
2.3.2.1.5	Insulation of pipes, vessels and equipment.....	84
2.3.2.1.6	Frequency converters on motors	85
2.3.2.1.7	Energy-efficient lighting.....	87
2.3.2.1.8	Energy efficiency plan	87
2.3.2.1.9	High-efficiency motors	88
2.3.2.1.10	Combustion regulation and control.....	89
2.3.2.2	Techniques related to steam systems	90
2.3.2.2.1	Standard and condensing economiser	90
2.3.2.2.2	Minimisation of the blowdown from the boiler	91
2.3.2.2.3	Avoidance of losses of flash steam from condensate return	92
2.3.2.2.4	Multistage evaporation	93
2.3.2.3	Techniques related to compressed air	98
2.3.2.3.1	Reduction of air leaks and optimisation of pressure settings	98
2.3.2.4	Techniques related to cooling/freezing	99
2.3.2.4.1	Optimisation of condensation and evaporation temperature of cooling systems.....	99
2.3.2.5	Techniques related to cleaning	101

2.3.2.5.1	Optimisation of chemical dosing and water use in CIP.....	101
2.3.2.6	Techniques related to cooking.....	101
2.3.2.6.1	Avoidance of precooking step if possible.....	101
2.3.3	Techniques to reduce water consumption	102
2.3.3.1	General processing techniques	102
2.3.3.1.1	Water recycling and/or reuse.....	102
2.3.3.1.2	Optimisation of water flow.....	104
2.3.3.1.3	Optimisation of water nozzles and hoses	106
2.3.3.1.4	Segregation of water streams	108
2.3.3.2	Techniques related to cleaning	109
2.3.3.2.1	Dry cleaning.....	109
2.3.3.2.2	Pigging system for pipes	110
2.3.3.2.3	High-pressure cleaning.....	113
2.3.3.2.4	Optimisation of chemical dosing and water use in cleaning-in-place	114
2.3.3.2.5	Low-pressure foam and/or gel cleaning	118
2.3.3.2.6	Optimised design and construction of equipment and process areas.....	119
2.3.3.2.7	Cleaning of equipment as soon as possible	121
2.3.3.2.8	Fitting of cleaning hoses with hand-operated triggers.....	122
2.3.3.3	Techniques related to cooling/freezing	123
2.3.3.3.1	Closed-circuit cooling	123
2.3.3.3.2	Recirculation of cooling water after electrochemical treatment	124
2.3.3.4	Techniques related to bottling	125
2.3.3.4.1	Dry disinfection.....	125
2.3.3.5	Techniques related to steam systems.....	126
2.3.3.5.1	Maximisation of condensate return	126
2.3.4	Techniques to avoid the use of harmful substances	127
2.3.4.1	Proper selection of cleaning chemicals and/or disinfectants	127
2.3.4.2	Reuse of cleaning chemicals in cleaning-in-place.....	128
2.3.4.3	Dry cleaning.....	128
2.3.4.4	Optimised design and construction of equipment and process areas.....	128
2.3.4.5	Use of refrigerants without ozone depletion potential and with low global warming potential.....	128
2.3.5	Techniques to increase resource efficiency.....	130
2.3.5.1	Anaerobic digestion	130
2.3.5.2	Use of residues	131
2.3.5.3	Separation of residues	133
2.3.5.4	Recovery and reuse of residues from the pasteuriser	135
2.3.5.5	Phosphorus recovery as struvite	137
2.3.5.6	Use of waste water for landspreading	137
2.3.6	Waste water treatment techniques.....	138
2.3.6.1	Preliminary, primary and general treatment	138
2.3.6.1.1	Equalisation.....	138
2.3.6.1.2	Neutralisation	139
2.3.6.1.3	Screening.....	140
2.3.6.1.4	Fat trap or oil separator for the removal of FOG and light hydrocarbons	142
2.3.6.1.5	Buffer storage for waste water	143
2.3.6.2	Secondary treatment.....	144
2.3.6.2.1	Aerobic treatment	144
2.3.6.2.2	Anaerobic treatment	152
2.3.6.2.3	Aerobic/anaerobic treatment	160
2.3.6.3	Nitrogen removal	164
2.3.6.3.1	Nitrification and denitrification.....	164
2.3.6.3.2	Partial nitritation-anaerobic ammonium oxidation.....	165
2.3.6.3.3	Ammonia stripping.....	166
2.3.6.4	Phosphorus recovery and/or removal	168
2.3.6.4.1	Phosphorus recovery as struvite	168
2.3.6.4.2	Precipitation	170

2.3.6.4.3	Enhanced biological phosphorus removal	172
2.3.6.5	Final solids removal.....	174
2.3.6.5.1	Coagulation and flocculation	174
2.3.6.5.2	Sedimentation	175
2.3.6.5.3	Filtration	176
2.3.6.5.4	Flotation.....	177
2.3.6.5.5	Membrane filtration	178
2.3.6.5.6	UV radiation	181
2.3.6.6	Natural treatment	182
2.3.6.6.1	Integrated constructed wetlands.....	182
2.3.6.7	Sludge and waste treatment	184
2.3.6.8	Analysis of key parameters	189
2.3.6.8.1	Chemical oxygen demand (COD).....	190
2.3.6.8.2	Total organic carbon (TOC).....	193
2.3.6.8.3	Biochemical oxygen demand in five days (BOD ₅)	195
2.3.6.8.4	Total suspended solids (TSS).....	197
2.3.6.8.5	Total nitrogen (TN).....	200
2.3.6.8.6	Total phosphorous (TP)	202
2.3.7	Techniques to reduce emissions to air	204
2.3.7.1	Techniques applicable for a number of pollutants	204
2.3.7.1.1	Collection of emissions to air at source and local exhaust ventilation.....	204
2.3.7.1.2	Exhaust gas recirculation	205
2.3.7.1.3	Combustion optimisation	207
2.3.7.2	Techniques to reduce dust emissions.....	207
2.3.7.2.1	Separator.....	207
2.3.7.2.2	Bag filter	208
2.3.7.2.3	Cyclone	211
2.3.7.2.4	Electrostatic precipitator	213
2.3.7.2.5	Packed bed filter	215
2.3.7.3	Techniques mainly used to reduce organic/odour emissions	216
2.3.7.3.1	Wet scrubber	216
2.3.7.3.2	Plate absorber.....	219
2.3.7.3.3	Adsorption	221
2.3.7.3.4	Biofilter.....	223
2.3.7.3.5	Bioscrubber.....	227
2.3.7.3.6	Thermal oxidation.....	229
2.3.7.3.7	Catalytic oxidation.....	232
2.3.7.3.8	Non-thermal plasma treatment.....	235
2.3.7.3.9	Extension of the height of the discharge stack.....	239
2.3.7.3.10	Increase of the stack discharge velocity.....	240
2.3.7.3.11	Odour management plan	241
2.3.7.4	Techniques to reduce NO _x emissions	242
2.3.7.4.1	Low-NO _x burners	242
2.3.8	Techniques to reduce noise.....	243
2.3.8.1	Low-noise equipment	243
2.3.8.2	Design of pipework to minimise noise emissions.....	245
2.3.8.3	Sound insulation of equipment	246
2.3.8.4	Appropriate location of equipment and buildings.....	247
2.3.8.5	Sound insulation of buildings	248
2.3.8.6	Noise abatement	249
2.3.8.7	Application of a spiral turbulence generator to a chimney to minimise noise emissions	250
2.3.8.8	Fitting of silencers to air inlets and exhausts	251
2.3.8.9	Management of on-site vehicle movements.....	252
2.3.8.10	Switching off of the engine and refrigerator unit of a vehicle during loading/unloading and when parked.....	254
2.4	EMERGING TECHNIQUES ACROSS THE FDM SECTOR	255

2.4.1	Use of UV/ozone in absorption for odour abatement.....	255
2.4.2	Electrochemical activation	255
2.4.3	Waste-activated sludge reduction and generation of carbon source for denitrification	256
2.4.4	Integrated fixed-film activated sludge systems with biological phosphorus removal.....	256
2.4.5	Microbial fuel cell-based treatment system.....	257
3	ANIMAL FEED	259
3.1	GENERAL INFORMATION ABOUT THE SECTOR	260
3.1.1	Compound feed for food-producing animals	260
3.1.2	Pet food	262
3.1.3	Feed for fur animals	262
3.1.4	Green fodder (dehydrated forage)	263
3.2	APPLIED PROCESSES AND TECHNIQUES	264
3.2.1	Compound feed for food-producing animals	264
3.2.1.1	General.....	264
3.2.1.2	Receipt and storage of raw materials	265
3.2.1.3	Size reduction of raw materials	265
3.2.1.4	Processing of raw materials.....	266
3.2.1.5	Product storage and dispatch.....	266
3.2.1.6	Cleaning activities.....	267
3.2.2	Pet food	267
3.2.2.1	General.....	267
3.2.2.2	Receipt and storage of raw materials	268
3.2.2.3	Size reduction of raw materials	269
3.2.2.4	Processing of raw materials.....	269
3.2.2.5	Product storage and dispatch.....	271
3.2.2.6	Cleaning activities.....	271
3.2.3	Feed for fur animals	272
3.2.3.1	General.....	272
3.2.3.2	Receipt and storage of raw materials	273
3.2.3.3	Processing of materials into the final product	273
3.2.3.4	Storage and dispatch of the final product.....	273
3.2.3.5	Cleaning activities.....	273
3.2.4	Green fodder (dehydrated forage)	273
3.2.4.1	First stages.....	273
3.2.4.2	Dehydration by the high-temperature dry process	274
3.2.4.3	Dehydration by the wet process	275
3.3	CURRENT CONSUMPTION AND EMISSION LEVELS	276
3.3.1	Energy consumption.....	276
3.3.2	Water consumption	276
3.3.3	Emissions to water	277
3.3.4	Emissions to air	277
3.3.4.1	Dust emissions from green fodder drying	277
3.3.4.2	Dust emissions from compound feed manufacturing	278
3.4	TECHNIQUES TO CONSIDER IN THE DETERMINATION OF BAT.....	280
3.4.1	Techniques to increase energy efficiency in green fodder drying.....	280
3.4.1.1	Use of predried fodder	280
3.4.1.2	Recycling of waste gas from the dryer	282
3.4.1.3	Use of waste heat for predrying	283
3.4.2	Techniques to reduce emissions to air.....	284
3.4.2.1	Techniques to reduce dust emissions from green fodder drying	284

3.4.2.1.1	Cyclone	284
3.4.2.1.2	Wet scrubber	285
3.4.2.2	Techniques to reduce dust emissions from compound feed manufacturing	286
3.4.2.2.1	Bag filter	286
3.4.2.2.2	Cyclone	287
3.4.2.3	Techniques to reduce odour	288
3.4.2.3.1	Non-thermal plasma treatment	288
3.4.2.3.2	Biofilter	288
4	BREWING	289
4.1	GENERAL INFORMATION ABOUT THE SECTOR	289
4.2	APPLIED PROCESSES AND TECHNIQUES	292
4.2.1	Wort production	293
4.2.1.1	Overview	293
4.2.1.2	Raw materials handling	294
4.2.1.3	Milling	294
4.2.1.4	Mashing	294
4.2.1.4.1	Malt mash	294
4.2.1.4.2	Adjunct mash	294
4.2.1.5	Mash filtration	295
4.2.1.6	Wort boiling	295
4.2.1.7	Separation and cooling of trub	295
4.2.1.8	High-gravity brewing	295
4.2.2	Fermentation / Beer processing area	296
4.2.2.1	Overview	296
4.2.2.2	Fermentation	296
4.2.2.3	Yeast handling	297
4.2.2.4	Maturation and storage	297
4.2.2.5	Filtration and stabilisation	298
4.2.3	Beer packaging and storage	298
4.2.3.1	Overview	298
4.2.3.2	Returnable bottles	299
4.2.3.3	Non-returnable bottles	300
4.2.3.4	Cans	300
4.2.3.5	Kegs	301
4.2.3.6	Plastic bottles	301
4.2.3.7	Warehouse storage	301
4.2.4	Non-alcoholic beer production	301
4.2.4.1	Fermentation-free brewing	302
4.2.4.2	Dilution	302
4.2.4.3	Alcohol removal (dealcoholisation)	302
4.2.4.3.1	Vacuum distillation	302
4.2.4.3.2	Water vapour / Gas stripping under vacuum	302
4.2.4.3.3	Dialysis	303
4.2.4.3.4	Reverse osmosis	303
4.2.4.4	Restricted alcohol fermentation	303
4.2.5	Cleaning and disinfection	304
4.3	CURRENT CONSUMPTION AND EMISSION LEVELS	306
4.3.1	Energy consumption	306
4.3.2	Water consumption	307
4.3.3	Solid output	308
4.3.4	Emissions to water	309
4.3.5	Emissions to air	310
4.3.5.1	Dust emissions	310
4.3.5.2	Odour	312

4.4	TECHNIQUES TO CONSIDER IN THE DETERMINATION OF BAT	313
4.4.1	Techniques to increase energy efficiency	313
4.4.1.1	Mash infusion process	313
4.4.1.2	Mashing-in at higher temperatures	314
4.4.1.3	Heat recovery from wort kettle vapour	315
4.4.1.4	Increase of the degree of high-gravity brewing	316
4.4.1.5	Integrated energy system in the CO ₂ recovery plant	317
4.4.1.6	Decrease of evaporation rate during wort boiling	318
4.4.1.7	Mixer in fermentation tank	318
4.4.2	Techniques to reduce water consumption	319
4.4.2.1	Reuse of hot water from wort cooling	319
4.4.2.2	Reuse of waste water from the lauter tun	320
4.4.2.3	Reuse of pasteurising water	322
4.4.3	Techniques to reduce waste	323
4.4.3.1	Recovery and (re)use of yeast after fermentation	323
4.4.3.2	Recovery and (re)use of natural filter material	324
4.4.3.3	Use of brewery surplus yeast, rest beer and soft drinks for bioethanol feedstock	325
4.4.4	Techniques to reduce emissions to air	326
4.4.4.1	Techniques to reduce dust emissions from the brewing process	326
4.4.4.1.1	Bag filter	326
4.4.4.1.2	Cyclone	328
4.4.4.2	Techniques to reduce odour	328
4.4.4.2.1	Heat recovery from wort kettle vapour	328
4.4.4.3	Carbon dioxide recovery and purification	328
4.5	EMERGING TECHNIQUES	331
4.5.1	External cooling of the fermentation tank	331
5	DAIRIES	333
5.1	GENERAL INFORMATION ABOUT THE SECTOR	333
5.2	APPLIED PROCESSES AND TECHNIQUES	335
5.2.1	Milk and cream	335
5.2.2	Condensed and powdered milk	339
5.2.3	Butter	341
5.2.4	Cheese	342
5.2.5	Yoghurt	344
5.2.6	Ice cream	346
5.2.7	Whey	346
5.2.8	Cleaning procedures in the dairy industry	347
5.2.8.1	Cleaning with chemicals	347
5.2.8.1.1	General approach	347
5.2.8.1.2	Dairy soils and the selection of the right cleaning chemicals	347
5.2.8.1.3	Biocides	348
5.2.8.2	CIP procedures	348
5.3	CURRENT CONSUMPTION AND EMISSION LEVELS	349
5.3.1	Energy consumption	349
5.3.2	Water consumption	351
5.3.3	Solid output	352
5.3.4	Emissions to water	354
5.3.5	Emissions to air	357
5.3.5.1	Dust emissions from dryers	357
5.3.6	Consumption of chemicals	358
5.4	TECHNIQUES TO CONSIDER IN THE DETERMINATION OF BAT	359
5.4.1	General environmental performance	359

5.4.1.1	Reduction of EDTA use by minimising milk fouling and milkstone formation by production planning	359
5.4.1.2	Use of computer-controlled milk transfer, pasteurisation, homogenisation and CIP equipment	360
5.4.2	Techniques to increase energy efficiency	362
5.4.2.1	Partial milk homogenisation	362
5.4.2.2	Energy-efficient homogeniser.....	362
5.4.2.3	Sterile water use in homogeniser	363
5.4.2.4	Use of continuous pasteurisers	364
5.4.2.5	Regenerative heat exchange in pasteurisation	365
5.4.2.6	Hibernation for pasteurisers and sterilisers	366
5.4.2.7	Ultra-high temperature process of milk without intermediate pasteurisation	367
5.4.2.8	Multistage drying in powder production.....	369
5.4.2.9	Precooling of ice-water.....	371
5.4.2.10	Production of cheese.....	372
5.4.2.10.1	High-temperature cheese ripening with later humidification and ionisation of the ventilation air	372
5.4.2.10.2	Use of ultrafiltration for protein standardisation of cheese milk.....	373
5.4.3	Techniques to reduce water consumption.....	374
5.4.3.1	Dry cleaning	374
5.4.3.2	Reduction of centrifuge cleaning requirements by improved preliminary milk filtration and clarification	374
5.4.3.3	Reuse and recycling of water.....	375
5.4.3.4	Water recycling by using membrane filtration techniques	377
5.4.4	Techniques to reduce waste	379
5.4.4.1	Separation of residues.....	379
5.4.4.2	Just-in-time mixing component filling.....	380
5.4.4.3	Optimised operation of centrifuges.....	381
5.4.4.4	Butter production.....	381
5.4.4.4.1	Rinsing of the cream heater with skimmed milk or water	381
5.4.4.5	Production of ice cream.....	382
5.4.4.5.1	Continuous freezing of ice cream mix	382
5.4.4.6	Cheese production	383
5.4.4.6.1	Minimisation of the generation of acid whey	383
5.4.4.6.2	Reduction of fat and cheese fines in whey.....	384
5.4.4.6.3	Recovery and use of whey	385
5.4.5	Techniques to reduce emissions to water.....	387
5.4.5.1	Salt management - Handling of brine in cheese production	387
5.4.6	Techniques to reduce emissions to air	388
5.4.6.1	Techniques to reduce dust emissions from dryers	388
5.4.6.1.1	Bag filter	388
5.4.6.1.2	Cyclone.....	392
5.4.6.1.3	Wet scrubber.....	393
6	ETHANOL PRODUCTION	395
6.1	GENERAL INFORMATION ABOUT THE SECTOR.....	395
6.2	APPLIED PROCESSES AND TECHNIQUES.....	396
6.3	CURRENT CONSUMPTION AND EMISSION LEVELS	399
6.3.1	Energy consumption	399
6.3.2	Water consumption	399
6.4	TECHNIQUES TO CONSIDER IN THE DETERMINATION OF BAT	400
6.4.1	Techniques to reduce emissions to air	400
6.4.1.1	Carbon dioxide recovery and purification	400
6.4.2	Techniques to reduce waste	400
6.4.2.1	Recovery and further processing of stillage distiller's dried grains with solubles.....	400

6.4.2.2	Recovery and (re)use of yeast after fermentation.....	401
7	FISH AND SHELLFISH PROCESSING.....	403
7.1	GENERAL INFORMATION ABOUT THE SECTOR	403
7.2	APPLIED PROCESSES AND TECHNIQUES	406
7.2.1	General	406
7.2.2	Preliminary processing.....	407
7.2.2.1	General	407
7.2.2.2	Freezing/Thawing	408
7.2.2.2.1	Thawing using water recirculation and air stirring.....	409
7.2.2.2.2	Thawing in containers filled with warm water with air bubbles at the bottom	409
7.2.2.2.3	Thawing by sprinkling.....	409
7.2.2.2.4	Thawing by 100 % water-saturated heated air	409
7.2.2.3	Grading.....	409
7.2.2.4	Scaling.....	410
7.2.2.5	Deheading and gutting	410
7.2.2.6	Filleting and skinning.....	411
7.2.3	Fish preservation methods.....	411
7.2.3.1	Canning	411
7.2.3.2	Salting	411
7.2.3.3	Smoking	411
7.2.3.4	Drying	413
7.3	CURRENT CONSUMPTION AND EMISSION LEVELS	414
7.3.1	Overview	414
7.3.2	Energy consumption.....	416
7.3.3	Water consumption	416
7.3.4	Emissions to water	416
7.3.5	Emissions to air	419
7.3.5.1	Odour	419
7.3.6	Solid output	419
7.4	TECHNIQUES TO CONSIDER IN THE DETERMINATION OF BAT	421
7.4.1	Techniques to reduce water consumption	421
7.4.1.1	General processing techniques	421
7.4.1.1.1	Removal of fat and viscera by vacuum	421
7.4.1.1.2	Use of the filtered recirculated scaling waste water for preliminary fish rinsing.....	421
7.4.1.1.3	Avoidance of scaling if the fish is subsequently skinned	422
	Avoidance of scaling if the fish is subsequently skinned.	422
7.4.1.1.4	Dry transport of fat, viscera, skin and fillets	423
7.4.1.2	Techniques related to cleaning	424
7.4.1.2.1	Dry cleaning	424
7.4.2	Techniques to reduce waste.....	425
7.4.2.1	Separation of residues	425
7.4.2.2	Use of only high-quality fish.....	425
7.4.3	Techniques to reduce emissions to air.....	426
7.4.3.1	Techniques to reduce TVOC emissions from smoke kilns and odour	426
7.4.3.1.1	Use of purified smoke	426
7.4.3.1.2	Biofilter	427
7.4.3.1.3	Non-thermal plasma treatment	428
7.4.3.1.4	Thermal oxidation of waste gases	428
7.4.3.1.5	Wet scrubber and electrostatic precipitator	431
8	FRUIT AND VEGETABLES	433
8.1	GENERAL INFORMATION ABOUT THE SECTOR	433

8.2	APPLIED PROCESSES AND TECHNIQUES	434
8.2.1	Peeling	435
8.2.1.1	Steam peeling – continuous process	435
8.2.1.2	Steam peeling – batch process	437
8.2.1.3	Abrasion peeling	437
8.2.1.4	Knife peeling	438
8.2.1.5	Wet caustic peeling	440
8.2.1.6	Dry caustic peeling	440
8.2.1.7	Enzymatic peeling	441
8.2.2	Blanching	441
8.2.2.1	Steam blanching with air cooling	441
8.2.2.2	Belt blanching with water cooling	442
8.2.2.3	Belt blanching with air cooling	443
8.2.2.4	Drum blancher with countercurrent water cooling	443
8.2.3	Ready meals containing predominantly fruit and vegetables	444
8.2.4	Fruit juice	444
8.2.5	Heat-treated fruit	445
8.2.6	Frozen fruit and vegetables	445
8.2.7	Fruit preserves	446
8.2.8	Dried fruit	446
8.2.9	Tomatoes	447
8.2.10	Potatoes	447
8.2.10.1	Potato fries	448
8.2.10.2	Potato crisps	448
8.2.11	Vegetable juice	449
8.2.12	Heat-treated and frozen vegetables	449
8.2.13	Pickling of vegetables	449
8.2.14	Vegetable drying	449
8.3	CURRENT CONSUMPTION AND EMISSION LEVELS	450
8.3.1	Energy consumption	450
8.3.2	Water consumption	451
8.3.3	Solid output	452
8.3.4	Emissions to water	453
8.3.5	Data for some fruit and vegetable products	456
8.3.5.1	Fresh-pack fruit and vegetables	456
8.3.5.2	Preserved fruit and vegetables	456
8.3.5.3	Frozen vegetables	458
8.3.5.4	Juices	459
8.3.5.5	Other products	459
8.4	TECHNIQUES TO CONSIDER IN THE DETERMINATION OF BAT	460
8.4.1	Techniques to increase energy efficiency	460
8.4.1.1	Cooling fruit and vegetables before freezing	460
8.4.2	Techniques to reduce water consumption	462
8.4.2.1	Dry cleaning	462
8.4.2.2	Water recycling	462
8.4.3	Techniques to reduce waste	464
8.4.3.1	Separation of residues	464
8.4.3.2	Use of automatic sorting machines, to reduce raw material losses	464
8.4.3.3	Recovery of starch in potato processing	465
8.5	EMERGING TECHNIQUES	467
8.5.1	Water recycling at the washing step for freshly cut vegetables after an O ₃ /UV treatment	467

8.5.2	Use of NEOW as an alternative to conventional sodium hypochlorite for disinfection of salads	468
9	GRAIN MILLING	471
9.1	GENERAL INFORMATION ABOUT THE SECTOR	471
9.2	APPLIED PROCESSES AND TECHNIQUES	472
9.2.1	General overview	472
9.2.2	Specific processes	473
9.3	CURRENT CONSUMPTION AND EMISSION LEVELS	474
9.3.1	Energy consumption.....	474
9.3.2	Water consumption	475
9.3.3	Emissions to air	476
9.3.3.1	Dust emissions	476
9.4	TECHNIQUES TO CONSIDER IN THE DETERMINATION OF BAT	478
9.4.1	Techniques to reduce emissions to air.....	478
9.4.1.1	Techniques to reduce dust emissions from the grain milling process	478
9.4.1.1.1	Bag filter.....	478
9.4.1.1.2	Cyclone	479
10	MEAT PROCESSING.....	481
10.1	GENERAL INFORMATION ABOUT THE SECTOR	481
10.2	APPLIED PROCESSES AND TECHNIQUES	484
10.2.1	General overview	484
10.2.2	Cleaning	493
10.2.3	Thawing processes	493
10.3	CURRENT CONSUMPTION AND EMISSION LEVELS	494
10.3.1	General information	494
10.3.1.1	Energy consumption.....	495
10.3.1.2	Water consumption	496
10.3.1.3	Solid output	497
10.3.1.4	Emissions to water	497
10.3.1.5	Emissions to air	499
10.3.2	Meat and poultry production	499
10.3.2.1	General information	499
10.3.2.2	Salami and sausage production	500
10.3.2.3	Freezing.....	500
10.3.2.4	Curing	500
10.3.2.5	Smoking	500
10.3.2.5.1	TVOC emissions to air from smoke kilns	501
10.3.2.6	Drying	501
10.3.2.7	Canning	501
10.4	TECHNIQUES TO CONSIDER IN THE DETERMINATION OF BAT	502
10.4.1	Techniques to reduce water consumption	502
10.4.1.1	Techniques related to cleaning	502
10.4.1.1.1	Dry cleaning.....	502
10.4.1.1.2	Minimisation of the production and use of flake ice	502
10.4.2	Techniques to reduce waste.....	503
10.4.2.1	Separation of residues	503
10.4.3	Techniques to reduce emissions to air.....	504
10.4.3.1	Techniques to reduce TVOC emissions from smoke kilns	504
10.4.3.1.1	Adsorption.....	504
10.4.3.1.2	Thermal oxidation of waste gases	504
10.4.3.1.3	Wet scrubber and electrostatic precipitator	506

10.4.3.1.4	Use of purified smoke.....	508
10.4.3.2	Techniques to reduce odour.....	509
10.4.3.2.1	Recirculation and burning of exhaust gases from frying	509
11	OILSEED PROCESSING AND VEGETABLE OIL REFINING	511
11.1	GENERAL INFORMATION ABOUT THE SECTOR.....	511
11.1.1	Oilseed processing	511
11.1.2	Vegetable oil refining	511
11.2	APPLIED PROCESSES AND TECHNIQUES.....	513
11.2.1	Oilseed processing	513
11.2.2	Vegetable oil refining	513
11.2.2.1	Refining of vegetable oils	513
11.2.2.1.1	Chemical refining of vegetable oils	513
11.2.2.1.2	Physical refining of vegetable oils	514
11.2.2.1.3	Differences between chemical and physical refining of vegetable oils.....	515
11.2.2.2	Degumming	516
11.2.2.3	Deodorisation.....	518
11.2.2.3.1	Single wet scrubber in combination with an alkaline closed-circuit system.....	518
11.2.2.3.2	Single wet scrubber in combination with dry/ice condensing.....	520
11.2.2.3.3	Double wet scrubber in combination with a once-through cooling system	522
11.2.2.4	Crystallisation of edible oils and fats.....	524
11.2.2.5	Further processing of edible oils and fats – margarine	524
11.3	CURRENT CONSUMPTION AND EMISSION LEVELS	525
11.3.1	Energy consumption	525
11.3.2	Water consumption	526
11.3.3	Solid output.....	527
11.3.4	Chemicals used	528
11.3.5	Emissions to water.....	529
11.3.6	Emissions to air.....	530
11.3.6.1	Dust emissions from seed processing / drying and cooling of meal	530
11.3.6.2	TVOC emissions.....	532
11.3.6.3	Hexane losses	532
11.3.6.4	Odour emissions	534
11.4	TECHNIQUES TO CONSIDER IN THE DETERMINATION OF BAT	535
11.4.1	Techniques to increase energy efficiency	535
11.4.1.1	Generation of an auxiliary vacuum.....	535
11.4.2	Techniques to reduce emissions to air	536
11.4.2.1	Reduction of dust emissions from seed handling and preparation.....	536
11.4.2.1.1	Bag filter	536
11.4.2.1.2	Cyclone.....	538
11.4.2.1.3	Wet scrubber	539
11.4.2.2	Reduction of dust emissions from the drying and cooling of meal.....	539
11.4.2.2.1	Cyclone.....	539
11.4.2.3	Reduction of odour emissions.....	541
11.4.2.3.1	Bioscrubber.....	541
11.4.2.3.2	Biofilter.....	541
11.4.2.3.3	Wet scrubber in combination with a biofilter	541
11.4.2.4	Recovery of hexane	542
11.4.2.4.1	Monitoring of hexane losses using a mass balance (bookkeeping process)	542
11.4.2.4.2	Countercurrent flow of meal and steam in the desolventiser-toaster	543
11.4.2.4.3	Evaporation from the oil/hexane mixture	545
11.4.2.4.4	Condensation in combination with a mineral oil wet scrubber	547
11.4.2.4.5	Gravitational phase separation in combination with distillation	548
11.5	EMERGING TECHNIQUES.....	550

11.5.1	Use of substances other than hexane for oil extraction	550
12	OLIVE OIL PROCESSING AND REFINING.....	551
12.1	GENERAL INFORMATION ABOUT THE SECTOR	551
12.2	APPLIED PROCESSES AND TECHNIQUES	552
12.2.1	Olive-pomace oil refining	554
12.2.2	Waste water treatment.....	554
12.2.2.1	Olive oil waste water.....	555
12.3	CURRENT CONSUMPTION AND EMISSION LEVELS.....	556
12.3.1	Energy consumption.....	556
12.3.2	Water consumption	556
12.3.3	Solid output	556
12.3.4	Emissions to water	556
12.4	TECHNIQUES TO CONSIDER IN THE DETERMINATION OF BAT.....	558
12.4.1	Techniques to reduce emissions to air.....	558
12.4.1.1	Production of olive-pomace oil	558
12.4.1.1.1	Mineral oil scrubber to recover hexane	558
12.4.1.1.2	Hexane recovery using a reboiler and gravity separator.....	558
13	SOFT DRINKS AND NECTAR/JUICE MADE FROM PROCESSED FRUIT AND VEGETABLES	559
13.1	GENERAL INFORMATION ABOUT THE SECTOR	559
13.2	APPLIED PROCESSES AND TECHNIQUES	561
13.3	CURRENT CONSUMPTION AND EMISSION LEVELS.....	562
13.3.1	Energy consumption.....	562
13.3.2	Water consumption	562
13.3.3	Emissions to water	563
13.4	TECHNIQUES TO CONSIDER IN THE DETERMINATION OF BAT.....	564
13.4.1	Techniques to increase energy efficiency	564
13.4.1.1	Application of a negative pressure for mixing purposes	564
13.4.1.2	Single pasteuriser for nectar/juice production.....	565
13.4.1.3	Hydraulic sugar transportation	566
13.4.1.4	Energy-efficient homogeniser for nectar/juice production.....	567
13.4.1.5	Use low-pressure blowers for bottle drying	567
13.4.2	Techniques to reduce water consumption	568
13.4.2.1	Water recycling	568
13.4.3	Techniques to reduce waste.....	569
13.4.3.1	Separation of residues	569
13.5	EMERGING TECHNIQUES	570
13.5.1	Optimised juice pasteurisation	570
14	STARCH PRODUCTION.....	571
14.1	GENERAL INFORMATION ABOUT THE SECTOR	571
14.2	APPLIED PROCESSES AND TECHNIQUES	573
14.2.1	Maize starch	573
14.2.2	Wheat starch.....	574
14.2.3	Potato starch	575
14.2.4	Sweeteners.....	576
14.2.5	Modified (physical/chemical) starches.....	576
14.2.6	Waste water treatment	576
14.3	CURRENT CONSUMPTION AND EMISSION LEVELS.....	578

14.3.1	Energy consumption	578
14.3.2	Water consumption	579
14.3.3	Solid output.....	579
14.3.4	Emissions to water	580
14.3.5	Emissions to air.....	580
14.3.5.1	Dust emissions from dryers	580
14.3.5.2	Dust emissions from preparation of raw materials	582
14.4	TECHNIQUES TO CONSIDER IN THE DETERMINATION OF BAT	583
14.4.1	Techniques to increase energy efficiency	583
14.4.1.1	Heat recovery for preheating the potato juice	583
14.4.2	Techniques to reduce water consumption.....	584
14.4.2.1	Countercurrent water use/reuse in starch washing.....	584
14.4.2.2	Reuse of process water in potato starch manufacturing.....	585
	Reuse of process water in potato starch manufacturing.....	585
14.4.3	Techniques to reduce waste	587
14.4.3.1	Separation of residues.....	587
14.4.4	Techniques to reduce emissions to air	587
14.4.4.1	Techniques to reduce dust emissions from dryers	587
14.4.4.1.1	Bag filter	587
14.4.4.1.2	Cyclone	589
14.4.4.1.3	Wet scrubber	591
14.4.4.2	Techniques to reduce dust emissions from preparation of raw materials	592
14.4.4.2.1	Bag filters.....	592
15	SUGAR MANUFACTURING	593
15.1	GENERAL INFORMATION ABOUT THE SECTOR.....	593
15.2	APPLIED PROCESSES AND TECHNIQUES.....	594
15.2.1	Sugar beet extraction	595
15.2.2	Drying of sugar beet pulp	595
15.2.3	Sugar cane.....	596
15.2.4	Sugar refining	596
15.3	CURRENT CONSUMPTION AND EMISSION LEVELS	598
15.3.1	Sugar beet	598
15.3.1.1	Energy consumption	598
15.3.1.2	Water consumption.....	598
15.3.1.3	Solid output.....	599
15.3.1.4	Emissions to water.....	600
15.3.1.5	Emissions to air from beet pulp dryers	602
15.3.1.5.1	Dust emissions	602
15.3.1.5.2	TVOC emissions.....	603
15.3.1.5.3	NO _x emissions	604
15.3.1.5.4	CO emissions	605
15.3.1.5.5	SO _x emissions	606
15.3.2	Cane sugar refining.....	607
15.4	TECHNIQUES TO CONSIDER IN THE DETERMINATION OF BAT	608
15.4.1	Techniques to increase energy efficiency	608
15.4.1.1	Pressing of sugar beet pulp	608
15.4.1.2	Indirect (steam drying) of beet pulp.....	608
15.4.1.3	Solar drying of sugar beet pulp.....	611
15.4.1.4	High-temperature drying of sugar beet pulp	612
15.4.1.5	Low-temperature drying of sugar beet pulp.....	614
15.4.1.5.1	Low-temperature (pre)drying of sugar beet pulp	614
15.4.1.5.2	Other uses of LTD dryers	615

15.4.1.6	Recycling of hot gases	616
15.4.2	Techniques to reduce water consumption	616
15.4.2.1	Water recycling	616
15.4.3	Techniques to reduce waste.....	617
15.4.3.1	Reduction of sugar beet soil tare	617
15.4.4	Techniques to reduce emissions to air.....	619
15.4.4.1	Reduction of dust emissions from beet pulp dryers	619
15.4.4.1.1	Cyclone	619
15.4.4.1.2	Wet scrubber	620
15.4.4.1.3	Use of gaseous fuels.....	620
15.4.4.1.4	Indirect (steam drying) of sugar beet pulp.....	621
15.4.4.1.5	Low-temperature (pre)drying of sugar beet pulp.....	621
15.4.4.1.6	Solar drying of beet pulp	621
15.4.4.2	Reduction of TVOC emissions from beet pulp dryers	622
15.4.4.2.1	Wet scrubber	622
15.4.4.3	Techniques to reduce SO _x emissions from beet pulp dryers.....	622
15.4.4.3.1	Wet scrubber	622
15.4.4.3.2	Use of natural gas or fuels with a low sulphur content.....	623
16	ADDITIONAL SECTORS (THUMBNAIL DESCRIPTIONS).....	625
16.1	DRY PASTA	625
16.1.1	Main processes and techniques	625
16.1.2	Energy consumption.....	627
16.1.3	Water consumption	627
16.2	BAKERY GOODS	628
16.2.1	Main processes and techniques	628
16.3	COFFEE MANUFACTURING	630
16.3.1	Main processes and techniques	630
16.3.2	Water consumption	635
16.3.3	Solid output	635
16.3.4	Emissions to air	635
16.4	DISTILLED BEVERAGES	638
16.4.1	Main processes and techniques	638
16.4.2	Energy consumption.....	639
16.4.3	Water consumption	639
16.4.4	Residues	639
16.4.5	Emissions to water	639
16.4.6	Emissions to air	640
16.5	WINE PRODUCTION	641
16.5.1	Main processes and techniques	641
16.5.2	Energy consumption.....	642
16.5.3	Water consumption	642
16.5.4	Emissions to water	642
16.5.5	Emissions to air	642
16.5.6	Residues	643
16.5.7	Natural tartaric acid production.....	643
16.5.7.1	Main processes and techniques	643
16.5.7.2	Energy consumption.....	644
16.5.7.3	Water consumption	644
16.5.7.4	Waste output	644
16.5.7.5	Emissions to water	644
16.6	CITRIC ACID PRODUCTION	645

16.6.1	Main processes and techniques.....	645
16.6.2	Water consumption.....	646
16.6.3	Residues.....	647
16.6.4	Emissions to water.....	647
16.7	YEAST.....	648
16.7.1	Main processes and techniques.....	648
16.7.2	Emissions to water.....	648
16.8	CONFECTIONERY.....	650
16.8.1	Main processes and techniques.....	650
16.9	MALTING.....	652
16.9.1	Main processes and techniques.....	652
16.9.2	Energy consumption.....	653
16.9.3	Water consumption.....	653
16.9.4	Residues.....	653
16.9.5	Emissions to water.....	653
16.9.6	Emissions to air.....	653
17	BEST AVAILABLE TECHNIQUES (BAT) CONCLUSIONS FOR THE FOOD, DRINK AND MILK INDUSTRIES	655
	SCOPE.....	655
	DEFINITIONS.....	657
	GENERAL CONSIDERATIONS	658
17.1	GENERAL BAT CONCLUSIONS	660
17.1.1	Environmental management systems.....	660
17.1.2	Monitoring.....	662
17.1.3	Energy efficiency.....	664
17.1.4	Water consumption and waste water discharge.....	665
17.1.5	Harmful substances.....	666
17.1.6	Resource efficiency.....	667
17.1.7	Emissions to water.....	668
17.1.8	Noise.....	670
17.1.9	Odour.....	671
17.2	BAT CONCLUSIONS FOR ANIMAL FEED.....	672
17.2.1	Energy efficiency.....	672
17.2.1.1	Compound feed/Pet food.....	672
17.2.1.2	Green fodder.....	672
17.2.2	Water consumption and waste water discharge.....	673
17.2.3	Emissions to air.....	673
17.3	BAT CONCLUSIONS FOR BREWING.....	674
17.3.1	Energy efficiency.....	674
17.3.2	Water consumption and waste water discharge.....	674
17.3.3	Waste.....	675
17.3.4	Emissions to air.....	675
17.4	BAT CONCLUSIONS FOR DAIRIES.....	676
17.4.1	Energy efficiency.....	676
17.4.2	Water consumption and waste water discharge.....	677
17.4.3	Waste.....	677
17.4.4	Emissions to air.....	678
17.5	BAT CONCLUSIONS FOR ETHANOL PRODUCTION.....	679

17.5.1	Waste.....	679
17.6	BAT CONCLUSIONS FOR FISH AND SHELLFISH PROCESSING.....	680
17.6.1	Water consumption and waste water discharge	680
17.6.2	Emissions to air	680
17.7	BAT CONCLUSIONS FOR THE FRUIT AND VEGETABLE SECTOR.....	682
17.7.1	Energy efficiency	682
17.7.2	Water consumption and waste water discharge	682
17.8	BAT CONCLUSIONS FOR GRAIN MILLING	683
17.8.1	Energy efficiency	683
17.8.2	Emissions to air	683
17.9	BAT CONCLUSIONS FOR MEAT PROCESSING	684
17.9.1	Energy efficiency	684
17.9.2	Water consumption and waste water discharge	684
17.9.3	Emissions to air	684
17.10	BAT CONCLUSIONS FOR OILSEED PROCESSING AND VEGETABLE OIL REFINING.....	686
17.10.1	Energy efficiency	686
17.10.2	Water consumption and waste water discharge	686
17.10.3	Emissions to air	687
17.10.4	Hexane losses	687
17.11	BAT CONCLUSIONS FOR SOFT DRINKS AND NECTAR/JUICE MADE FROM PROCESSED FRUIT AND VEGETABLES	689
17.11.1	Energy efficiency	689
17.11.2	Water consumption and waste water discharge	689
17.12	BAT CONCLUSIONS FOR STARCH PRODUCTION.....	690
17.12.1	Energy efficiency	690
17.12.2	Water consumption and waste water discharge	690
17.12.3	Emissions to air	691
17.13	BAT CONCLUSIONS FOR SUGAR MANUFACTURING.....	692
17.13.1	Energy efficiency	692
17.13.2	Water consumption and waste water discharge.....	692
17.13.3	Emissions to air	693
17.14	DESCRIPTION OF TECHNIQUES	695
17.14.1	Emissions to water	695
17.14.2	Emissions to air	696
18	CONCLUDING REMARKS AND RECOMMENDATIONS FOR FUTURE WORK.....	697
19	ANNEXES.....	701
19.1	ANNEX I - INSTALLATIONS THAT PARTICIPATED IN THE FDM DATA COLLECTION	701
19.2	ANNEX II - PROCESSING TECHNIQUES AND UNIT OPERATIONS	735
19.2.1	Materials reception and preparation	735
19.2.1.1	Materials handling and storage	735
19.2.1.2	Sorting/screening, grading, dehulling, destemming/destalking and trimming	735
19.2.2	Size reduction, mixing and forming	736
19.2.2.1	Cutting, slicing, chopping, mincing, pulping and pressing	736
19.2.2.2	Mixing/blending, homogenisation and conching	737
19.2.2.3	Grinding/milling and crushing	738
19.2.3	Separation techniques.....	739
19.2.3.1	Extraction	739
19.2.3.2	Centrifugation	740

19.2.3.3	Filtration	741
19.2.4	Heat processing.....	742
19.2.4.1	Cooking and boiling	742
19.2.4.2	Pasteurisation, sterilisation and UHT treatment	743
19.2.5	Concentration by heat	744
19.2.5.1	Evaporation (liquid to liquid)	744
19.2.5.2	Dehydration (solid to solid)	747
19.2.6	Processing by the removal of heat	749
19.2.6.1	Freezing	749
19.2.7	Utility processes.....	751
19.2.7.1	Vacuum generation.....	751
GLOSSARY.....		753
I.	ISO COUNTRY CODES	754
II.	MONETARY UNITS	755
III.	UNIT PREFIXES, NUMBER SEPARATORS AND NOTATIONS.....	756
IV.	UNITS AND MEASUREMENTS	757
V.	CHEMICAL ELEMENTS	759
VI.	CHEMICAL FORMULAE COMMONLY USED IN THIS DOCUMENT	760
VII.	ACRONYMS.....	761
VIII.	TECHNICAL DEFINITIONS.....	764
REFERENCES.....		769

List of figures

Figure 2.1:	Ideal Sinner's circle	26
Figure 2.2:	Distribution of FDM installations participating in the data collection according to the type of discharge	30
Figure 2.3:	Types and classification of filters	42
Figure 2.4:	Flow chart for the selection of odour abatement techniques.....	48
Figure 2.5:	Flow sheet for the selection of odour abatement equipment.....	53
Figure 2.6:	Continuous improvement in an EMS model.....	69
Figure 2.7:	MVR evaporator principle.....	95
Figure 2.8:	Flow chart of a four-stage MVR milk evaporator system.....	96
Figure 2.9:	Comparison of the operating costs of TVR and MVR evaporators	97
Figure 2.10:	Optimising the freezing tunnels in the production of deep-frozen vegetables.....	100
Figure 2.11:	Pigging system.....	111
Figure 2.12:	Flow sheet of a cleaning-in-place system	115
Figure 2.13:	A CIP system for the bottling process in a brewery	116
Figure 2.14:	Scheme for beverage processing with in-line blending and recovery functions	136
Figure 2.15:	Simplified process flow diagram of the MBR system	160
Figure 2.16:	The ammonia stripping process	166
Figure 2.17:	Flow diagram for one example of phosphorus recovery as struvite	168
Figure 2.18:	Phosphorus removal by chemical precipitation	171
Figure 2.19:	Example of a membrane unit implemented in a dairy	179
Figure 2.20:	The principle of cross-flow filtration, compared to dead-end filtration.....	180
Figure 2.21:	COD concentration in the effluent of the WWTP (direct discharge) in FDM installations (1 of 4)	191
Figure 2.22:	COD concentration in the effluent of the WWTP (direct discharge) in FDM installations (2 of 4)	191
Figure 2.23:	COD concentration in the effluent of the WWTP (direct discharge) in FDM installations (3 of 4)	192
Figure 2.24:	COD concentration in the effluent of the WWTP (direct discharge) in FDM installations (4 of 4)	192
Figure 2.25:	COD specific load in the effluent of the WWTP (direct discharge) in FDM installations	193
Figure 2.26:	TOC concentration in the effluent of the WWTP (direct discharge) in FDM installations	194
Figure 2.27:	TOC specific load in the effluent of the WWTP (direct discharge) in FDM installations.	194
Figure 2.28:	BOD ₅ concentration in the effluent of the WWTP (direct discharge) in FDM installations (1 of 3)	195
Figure 2.29:	BOD ₅ concentration in the effluent of the WWTP (direct discharge) in FDM installations (2 of 3)	196
Figure 2.30:	BOD ₅ concentration in the effluent of the WWTP (direct discharge) in FDM installations (3 of 3)	196
Figure 2.31:	BOD ₅ specific load in the effluent of the WWTP (direct discharge) in FDM installations	197
Figure 2.32:	TSS concentration in the effluent of the WWTP (direct discharge) in FDM installations (1 of 3)	198
Figure 2.33:	TSS concentration in the effluent of the WWTP (direct discharge) in FDM installations (2 of 3)	198
Figure 2.34:	TSS concentration in the effluent of the WWTP (direct discharge) in FDM installations (3 of 3)	199
Figure 2.35:	TSS specific load in the effluent of the WWTP (direct discharge) in FDM installations..	199
Figure 2.36:	TN concentration in the effluent of the WWTP (direct discharge) in FDM installations (1 of 2)	200
Figure 2.37:	TN concentration in the effluent of the WWTP (direct discharge) in FDM installations (2 of 2)	201
Figure 2.38:	TN specific load in the effluent of the WWTP (direct discharge) in FDM installations ...	201
Figure 2.39:	TP concentration in the effluent of the WWTP (direct discharge) in FDM installations (1 of 3)	202
Figure 2.40:	TP concentration in the effluent of the WWTP (direct discharge) in FDM installations (2 of 3)	203
Figure 2.41:	TP concentration in the effluent of the WWTP (direct discharge) in FDM installations (3 of 3)	203
Figure 2.42:	TP specific load in the effluent of the WWTP (direct discharge) in FDM installations	204
Figure 2.43:	Picture of an industrial bag filter	209
Figure 2.44:	Operational principle of a cyclone.....	211
Figure 2.45:	Typical arrangement of an electrostatic precipitator (only two zones shown).....	213

Figure 2.46: Spray chamber layout.....	217
Figure 2.47: Plate absorber layout	220
Figure 2.48: Biofilter layout	224
Figure 2.49: Bioscrubber layout	228
Figure 2.50: Thermal oxidiser layout	230
Figure 2.51: Catalytic oxidiser incineration layout.....	233
Figure 2.52: Industrial non-thermal plasma treatment equipment	236
Figure 2.53: The effect of the number of fan blades on the distance of noise transmission	244
Figure 2.54: Reduction in noise emissions from a chimney	250
Figure 3.1: General overview of the feed chain.....	259
Figure 3.2: Origin of feed (in million tonnes) in the EU-28 in 2014	260
Figure 3.3: Feed materials in the EU-27 feed industry in 2014	261
Figure 3.4: Activities undertaken in the manufacture of compound animal feed	265
Figure 3.5: Manufacture of pet food.....	268
Figure 3.6: Manufacture of dry pet food.....	270
Figure 3.7: Manufacture of wet pet food	271
Figure 3.8: Manufacture of feed for fur animals.....	272
Figure 3.9: Three-pass drying drum	274
Figure 3.10: Centrifuge system in a dehydration site	275
Figure 3.11: Specific energy consumption (MWh/tonne of products) in animal feed production.....	276
Figure 3.12: Specific waste water discharge in animal feed production (m ³ /tonne of products) for all types of discharges	277
Figure 3.13: Total dust emissions to air from compound feed manufacturing (1 of 2)	278
Figure 3.14: Total dust emissions to air from compound feed manufacturing (2 of 2)	278
Figure 3.15: Tonnes of water to be evaporated depending on the humidity of the fodder for one tonne of pellets	281
Figure 3.16: Implementation of a low-temperature predryer on a dehydration site.....	283
Figure 4.1: Beer production in the EU-28 in 2016 (in 1 000 hl).....	289
Figure 4.2: Beer consumption in the EU-28 in 2016 (in 1 000 hl)	290
Figure 4.3: Number of active breweries in the EU-28 in 2016.....	291
Figure 4.4: Overview of the beer production process.....	292
Figure 4.5: Scheme of wort production	293
Figure 4.6: Scheme of fermentation / Beer processing	296
Figure 4.7: Scheme of returnable bottles line	299
Figure 4.8: Scheme of non-returnable bottles line.....	300
Figure 4.9: Scheme of canning line	300
Figure 4.10: Scheme of kegging line	301
Figure 4.11: Bottle cleaning and rinsing steps.....	304
Figure 4.12: Specific energy consumption (MWh/hl of products) in brewing	307
Figure 4.13: Specific water consumption (m ³ /hl of products) in brewing	307
Figure 4.14: Co-product, by-product and solid waste quantities from a brewery producing 1 million hl beer/yr.....	308
Figure 4.15: Specific waste water discharge (m ³ /hl of products) in brewing for all types of discharges.....	310
Figure 4.16: Total dust emissions to air from the brewing process (1 of 2)	311
Figure 4.17: Total dust emissions to air from the brewing process (2 of 2)	311
Figure 4.18: Energy recovery from vapour condensation.....	315
Figure 4.19: Process flow diagram of a CO ₂ conditioning system in a large brewery.....	329
Figure 5.1: Production and use of milk in the EU-28 in 2014 (million tonnes).....	333
Figure 5.2: Collection of cows' milk by dairies in 2014 (% share of EU-28 total)	334
Figure 5.3: Utilisation of whole milk in the EU-28 in 2014	334
Figure 5.4: Short-time pasteurised milk process.....	336
Figure 5.5: Production of UHT milk	337
Figure 5.6: Production of sterilised milk	338
Figure 5.7: Flow sheet of processes for condensed products (e.g. UHT condensed milk) and intermediate products (e.g. milk concentrates).....	339
Figure 5.8: Flow sheet of powdered milk production.....	340
Figure 5.9: Continuous butter-making	342
Figure 5.10: Manufacture of cheese	343
Figure 5.11: Yoghurt production	345
Figure 5.12: Specific energy consumption (MWh/tonne of raw materials) in production of market milk	349
Figure 5.13: Specific energy consumption (MWh/tonne of raw materials) in production of cheese.....	350
Figure 5.14: Specific energy consumption (MWh/tonne of raw materials) in production of powder	350

Figure 5.15:	Specific energy consumption (MWh/tonne of raw materials) in production of fermented milk.....	351
Figure 5.16:	Flow chart of food waste in a typical dairy.....	352
Figure 5.17:	Typical losses of milk in the dairy industry.....	354
Figure 5.18:	Specific waste water discharge (m ³ /tonne of raw materials) in production of market milk.....	355
Figure 5.19:	Specific waste water discharge (m ³ /tonne of raw materials) in production of cheese.....	355
Figure 5.20:	Specific waste water discharge (m ³ /tonne of raw materials) in production of powder.....	356
Figure 5.21:	Specific waste water discharge (m ³ /tonne of raw materials) in production of fermented milk.....	356
Figure 5.22:	Total dust emissions to air from dryers (1 of 2).....	357
Figure 5.23:	Total dust emissions to air from dryers (2 of 2).....	357
Figure 5.24:	Processing flow sheet for a dairy producing milk.....	360
Figure 5.25:	Comparison of UHT processes with and without the intermediate pasteurisation step.....	368
Figure 5.26:	A two-stage drying process in a large dairy.....	370
Figure 5.27:	Water recycling scheme in a dairy.....	378
Figure 5.28:	Flow diagram of the membrane processing system.....	385
Figure 5.29:	Whey recovery using turbidity measurement.....	386
Figure 5.30:	Example treatment for emissions to air from the drying of whey powder.....	389
Figure 6.1:	Ethanol production process.....	396
Figure 7.1:	Fish and fishery products in live weight and fish contribution to protein supply (2012) ..	403
Figure 7.2:	Seafood products balance in the EU in 2011 (live weight equivalent).....	404
Figure 7.3:	Fisheries production (tonnes) in Nordic countries by capture and aquaculture in 2012.....	404
Figure 7.4:	Salmon filleting machine.....	407
Figure 7.5:	Heading, gutting and roe recovery machine.....	408
Figure 7.6:	Vibrating grading machine.....	410
Figure 7.7:	Equipment used for the dry removal of viscera.....	423
Figure 7.8:	Flow diagram showing the origin and process management of the hot gas from the waste gas cleaning system of a smokehouse.....	429
Figure 7.9:	Mass balance of a waste gas treatment system with direct flame thermal oxidation.....	430
Figure 8.1:	Steam peeling process in an example potato processing installation.....	436
Figure 8.2:	Fast steam peeling.....	437
Figure 8.3:	Flow diagram of fruit and vegetable canning.....	439
Figure 8.4:	The process for deep-frozen fruit and vegetables.....	446
Figure 8.5:	Main unitary operations of industrial tomato derivatives process.....	447
Figure 8.6:	Specific energy consumption (MWh/tonne of products) in fruit and vegetable production.....	450
Figure 8.7:	Specific water consumption (m ³ /tonne of products) in fruit and vegetable production.....	451
Figure 8.8:	Specific waste water discharge (m ³ /tonne of products) in fruit and vegetable production for all types of discharges.....	454
Figure 8.9:	Waste water produced in fruit and vegetable processing.....	455
Figure 8.10:	Installation of a water cooler in the ice-water trough.....	460
Figure 8.11:	Installation of an evaporator plate under the ice-water trough.....	461
Figure 9.1:	Specific energy consumption (MWh/tonne of products) in grain milling.....	474
Figure 9.2:	Specific water consumption (m ³ /tonne of products) in grain milling.....	475
Figure 9.3:	Total dust emissions to air from the grain milling process (1 of 2).....	476
Figure 9.4:	Total dust emissions to air from the grain milling process (2 of 2).....	477
Figure 10.1:	Total meat consumption in the EU in kg per capita (retail weight).....	482
Figure 10.2:	Specific energy consumption (MWh/tonne of raw materials) in meat processing.....	496
Figure 10.3:	Specific water consumption (m ³ /tonne of raw materials) in meat processing.....	497
Figure 10.4:	Specific waste water discharge (m ³ /tonne of raw materials) in meat processing for all types of discharges.....	498
Figure 10.5:	Difference in COD specific loads between meat installations including and excluding selected processes.....	498
Figure 10.6:	Difference in TSS specific loads between meat installations including and excluding selected processes.....	499
Figure 10.7:	Heat and oil recovery with heat exchangers mounted in the fryer exhaust hood.....	510
Figure 11.1:	Chemical refining of vegetable oils.....	514
Figure 11.2:	Basic flow diagram for the acid degumming of vegetable oil.....	517
Figure 11.3:	Basic flow diagram of an alkaline closed-circuit cooling water system as a part of a deodoriser vacuum system.....	519
Figure 11.4:	Basic flow diagram of a single scrubber in combination with a DC system.....	521
Figure 11.5:	Basic flow diagram of the double scrubber arrangement in deodorisation.....	523

Figure 11.6: Specific energy consumption (MWh/tonne of oil produced) in integrated crushing and refining	525
Figure 11.7: Specific energy consumption (MWh/tonne of oil produced) in stand-alone refining	526
Figure 11.8: Specific water consumption (m ³ /tonne of oil produced) in oilseed processing and vegetable oil refining.....	526
Figure 11.9: Specific waste water discharge (m ³ /tonne of oil produced) in integrated crushing and refining for all types of discharges	529
Figure 11.10: Specific waste water discharge (m ³ /tonne of oil produced) in stand-alone refining for all types of discharges	529
Figure 11.11: Total dust emissions to air from seed processing (1 of 3)	530
Figure 11.12: Total dust emissions to air from seed processing (2 of 3)	531
Figure 11.13: Total dust emissions to air from seed processing (3 of 3)	531
Figure 11.14: TVOC emissions to air from oilseed processing and vegetable oil refining	532
Figure 11.15: Specific hexane losses (kg per tonne of seeds or beans processed).....	534
Figure 11.16: Basic flow diagram of wet dust emission separation by cyclones.....	540
Figure 11.17: Countercurrent flow in the desolventiser-toaster.....	544
Figure 11.18: Vapour-heat integration in the desolventiser-toaster.....	546
Figure 11.19: Mineral oil system and related process steps	547
Figure 11.20: Process flow diagram for hexane recovery from process water in the extraction of unrefined vegetable oils	549
Figure 11.21: Schematic representation of the processing of rapeseed. Left) classical method and right) processing according to the concept of ethanolic, mild extraction	550
Figure 12.1: Production of olives for olive oil by main producing EU Member States in 2014 (% share of EU-28 production)	551
Figure 13.1: Specific energy consumption (MWh/hl of products) in soft drinks and nectar/juice production	562
Figure 13.2: Specific water consumption (m ³ /hl of products) in soft drinks and nectar/juice production	563
Figure 13.3: Specific waste water discharge (m ³ /hl of products) in soft drinks and nectar/juice production for all types of discharges	563
Figure 13.4: Comparison between single- and dual-line solution.....	565
Figure 14.1: Starch production in the EU-28 (2014)	571
Figure 14.2: Starch production in the EU-28.....	572
Figure 14.3: Main starch applications in the EU-28 (2014)	572
Figure 14.4: Starch production process	573
Figure 14.5: Maize starch production process	574
Figure 14.6: Wheat starch production process.....	575
Figure 14.7: Potato starch production process.....	575
Figure 14.8: Specific energy consumption (MWh/tonne of raw materials) in starch production	578
Figure 14.9: Specific water consumption (m ³ /tonne of raw materials) in starch production.....	579
Figure 14.10: Specific waste water discharge (m ³ /tonne of raw materials) in starch production for all types of discharges	580
Figure 14.11: Total dust emissions to air from dryers (1 of 2)	581
Figure 14.12: Total dust emissions to air from dryers (2 of 2)	581
Figure 14.13: Water circuit in a potato starch installation	585
Figure 15.1: Distribution of sugar production in the EU-28 (2015)	593
Figure 15.2: Product range in a sugar factory.....	594
Figure 15.3: Specific energy consumption (MWh/tonne of sugar beet) from sugar beet processing	598
Figure 15.4: Specific water consumption (m ³ /tonne of sugar beet) in sugar beet processing.....	599
Figure 15.5: Major material streams during beet sugar production	600
Figure 15.6: Specific waste water discharge (m ³ /tonne of beet) from sugar beet processing for all types of discharges	601
Figure 15.7: Total dust emissions to air from beet pulp dryers (concentration normalised at 16 % O ₂)	602
Figure 15.8: Average NO _x emissions to air from beet pulp dryers	604
Figure 15.9: Total CO emissions to air from beet pulp dryers.....	605
Figure 15.10: Average SO _x emissions to air from beet pulp dryers (concentration normalised at 16 % O ₂)	606
Figure 15.11: Total dust emissions from handling and preparation of raw materials in cane sugar refining	607
Figure 15.12: Pressurised steam fluidised bed dryer	610
Figure 15.13: Reduction of soil tare in Sweden.....	618
Figure 16.1: Summary of the dry pasta production process	626
Figure 16.2: Batch roaster used by a German coffee company	632

Figure 16.3: Continuous coffee roasting process used by a German company	633
Figure 16.4: CO and NO ₂ emissions at different measured points in an Italian coffee installation	636
Figure 16.5: Citric acid fermentation process	646
Figure 19.1: Distribution of FDM installations by main FDM sectors	734
Figure 19.2: The principle of falling film evaporation	746
Figure 19.3: Milk evaporation using a falling film	746

List of tables

Table 1.1:	Structure and production of the food and drink industry by Member State in the EU-28.....	1
Table 1.2:	Structure and production of some food and drink sectors in the EU-28.....	2
Table 1.3:	Summary of existing FDM installations requiring a permit by activity category in Annex I to Directive 2010/75/EU (reference period 2012–2013).....	3
Table 1.4:	Top export destinations of EU-28 FDM products in 2014.....	5
Table 1.5:	Origins of top imports of non-EU FDM products in 2014.....	5
Table 1.6:	Exports by sector in the EU-28 in 2014.....	6
Table 1.7:	Key environmental issues for emissions to air and to water agreed on at the kick-off meeting for the review of the FDM BREF.....	12
Table 2.1:	The processing techniques and unit operations most commonly used in the FDM sector ...	13
Table 2.2:	Typical cooling processes in the FDM sector.....	17
Table 2.3:	Typical freezing processes in the FDM sector.....	17
Table 2.4:	Waste water treatment techniques reported in the FDM data collection.....	32
Table 2.5:	Advantages and disadvantages of aerobic waste water treatment processes.....	34
Table 2.6:	Advantages and disadvantages of anaerobic waste water treatment processes.....	35
Table 2.7:	Common operational problems experienced with biological treatment processes.....	37
Table 2.8:	End-of-pipe treatment techniques for emissions to air reported in the FDM data collection.....	39
Table 2.9:	Key parameters for the end-of-pipe selection procedure.....	40
Table 2.10:	Comparisons of some separation techniques.....	41
Table 2.11:	Typical absorber design guidelines.....	43
Table 2.12:	Advantages and disadvantages of biological treatment.....	45
Table 2.13:	Data sheet for collecting information on odorous emissions.....	50
Table 2.14:	Checklist for abnormal operation.....	50
Table 2.15:	A typical odour measurement programme using simplified measurements from an unspecified food manufacturing site.....	51
Table 2.16:	Summary of generalised criteria for selecting odour/VOC abatement techniques.....	52
Table 2.17:	Ranges of yearly average concentrations of COD in the effluent of the WWTP.....	57
Table 2.18:	Ranges of yearly average specific loads of COD in the effluent of the WWTP.....	57
Table 2.19:	Ranges of yearly average concentrations of TOC in the effluent of the WWTP.....	58
Table 2.20:	Ranges of yearly average specific loads of TOC in the effluent of the WWTP.....	58
Table 2.21:	Ranges of yearly average concentrations of BOD ₅ in the effluent of the WWTP.....	59
Table 2.22:	Ranges of yearly average specific loads of BOD ₅ in the effluent of the WWTP.....	59
Table 2.23:	Ranges of yearly average concentrations of TSS in the effluent of the WWTP.....	60
Table 2.24:	Ranges of yearly average specific loads of TSS in the effluent of the WWTP.....	60
Table 2.25:	Ranges of yearly average concentrations of NH ₄ -N in the effluent of the WWTP.....	61
Table 2.26:	Ranges of yearly average specific loads of NH ₄ -N in the effluent of the WWTP.....	61
Table 2.27:	Ranges of yearly average concentrations of TN in the effluent of the WWTP.....	62
Table 2.28:	Ranges of yearly average specific loads of TN in the effluent of the WWTP.....	62
Table 2.29:	Ranges of yearly average concentrations of TP in the effluent of the WWTP.....	63
Table 2.30:	Ranges of yearly average specific loads of TP in the effluent of the WWTP.....	63
Table 2.31:	Ranges of yearly average concentrations of Cl ⁻ in the effluent of the WWTP.....	64
Table 2.32:	Ranges of yearly average specific loads of Cl ⁻ in the effluent of the WWTP.....	64
Table 2.33:	Ranges of abatement efficiencies for the WWTP in FDM installations.....	65
Table 2.34:	Information for each technique.....	67
Table 2.35:	Examples of use of level sensors in FDM processing.....	74
Table 2.36:	Examples of the use of conductivity measurement in the FDM sector.....	76
Table 2.37:	Typical applications of conductivity measurement in the FDM sector.....	76
Table 2.38:	Examples of the use of turbidity measurement in the FDM sector.....	77
Table 2.39:	Various examples of heat recovery in the FDM sector.....	80
Table 2.40:	Potential savings by reducing boiler blowdown in the deep freezing of vegetables.....	91
Table 2.41:	Comparison of efficiencies of multi-effect evaporators in the dairy industry.....	94
Table 2.42:	Examples of the use of flow control in the FDM sector.....	105
Table 2.43:	Typical applications of flow measurements in the FDM sector.....	105
Table 2.44:	Environmental benefits and associated cost reduction using pigging systems.....	112
Table 2.45:	Reduction in water and energy consumption during sanitation of hygienically designed equipment compared to conventional equipment.....	120
Table 2.46:	Water savings in sanitation of hygienically designed versus conventional equipment.....	120
Table 2.47:	Market price of eco-hygienic certified equipment.....	121
Table 2.48:	Examples of sources of animal feed from FDM manufacturing for human consumption..	132
Table 2.49:	Performance data of an activated sludge WWTP reported for the brewing sector.....	145

Table 2.50:	Characterisation of a typical SBR.....	148
Table 2.51:	Reported performance of a UASB reactor in the brewing sector	153
Table 2.52:	Reported performance of an EGSB reactor in the brewing sector	159
Table 2.53:	Advantages and disadvantages associated with membrane bioreactors.....	162
Table 2.54:	Design parameters for ammonia stripping of industrial waste water (condensate) from the sugar sector	167
Table 2.55:	Total phosphorus emission levels from five Finnish potato starch installations with an activated sludge process and simultaneous precipitation.....	171
Table 2.56:	Phosphorus removal efficiencies of various waste water treatment techniques.....	173
Table 2.57:	Typical performance data of the brewery sector after sedimentation	175
Table 2.58:	Advantages and disadvantages of sedimentation.....	175
Table 2.59:	Performance levels reported for an ICW	183
Table 2.60:	Symbols used in the graphs of Section 2.3.6.8	189
Table 2.61:	Abbreviations used in the graphs of Section 2.3.6.8 (1 of 2).....	189
Table 2.62:	Abbreviations used in the graphs of Section 2.3.6.8 (2 of 2).....	190
Table 2.63:	Comparison between different bag filter systems	209
Table 2.64:	Average values of periodic measurements of dust in dryer emissions after treatment in an electrostatic precipitator (dry basis)	214
Table 2.65:	Dust removal from air – overview of wet scrubbers.....	218
Table 2.66:	Properties of activated carbon.....	221
Table 2.67:	Principle of operation of the main types of adsorbers.....	222
Table 2.68:	Conditions at different stages of thermal oxidation	230
Table 2.69:	Volumes treated at some installations that apply non-thermal plasma treatment to reduce odour emissions	237
Table 2.70:	A guide to the noise reduction expected from reducing fan speeds.....	244
Table 2.71:	Noise measurements (mean of three independent measurements) from a German brewery	252
Table 2.72:	Calculated partial rating levels for materials transport and transhipment processes.....	253
Table 3.1:	Specific water consumption in animal feed production	276
Table 3.2:	Total dust emissions to air from green fodder drying (dry basis)	277
Table 3.3:	Symbols used in the graphs for emissions to air	279
Table 3.4:	Abbreviations used in the graphs for emissions to air	279
Table 3.5:	Dust emissions to air from green fodder drying after treatment in a cyclone (dry basis) ..	285
Table 3.6:	Dust emissions to air from compound feed manufacturing after treatment in a bag filter (dry basis)	286
Table 3.7:	Dust emissions to air from compound feed manufacturing after treatment in a cyclone (dry basis)	287
Table 4.1:	Heat consumption for different brewery departments/processes	306
Table 4.2:	Waste water production in different brewery departments/processes.....	309
Table 4.3:	Energy consumption in the brewhouse of a large brewery with a mash infusion process .	313
Table 4.4:	Waste water characteristics in a brewery	321
Table 4.5:	Summary of the pollution reduction results when treating lauter tun waste water	321
Table 4.6:	Dust emissions to air from brewing processes after treatment in a bag filter (dry basis) ..	327
Table 4.7:	Dust emissions to air from brewing processes after treatment in a cyclone (dry basis)	328
Table 5.1:	Water consumption in European dairies (years 2012-2014).....	351
Table 5.2:	Product losses in some processes in the dairy industry.....	353
Table 5.3:	Solid output per tonne of processed milk	353
Table 5.4:	Consumption of cleaning agents used in European dairies	358
Table 5.5:	Comparison between two different homogenisation devices.....	363
Table 5.6:	Energy reduction in a UHT unit by applying hibernation.....	367
Table 5.7:	Savings in water and energy consumption in a dairy using UF for protein standardisation	373
Table 5.8:	Water recycling opportunities at dairies	376
Table 5.9:	Dust emissions to air from a dryer after treatment in a bag filter (dry basis)	389
Table 5.10:	Average and maximum values of continuous measurements of dust in dryer emissions to air after treatment in a bag filter (dry basis)	391
Table 5.11:	Dust emissions to air from a dryer after treatment in a cyclone (dry basis).....	392
Table 5.12:	Dust emissions to air from a dryer after treatment in a wet scrubber (dry basis).....	393
Table 6.1:	Types of ethanol by industrial sector	395
Table 6.2:	Consumption data for the drying of DDGS	400
Table 7.1:	EU's main suppliers of seafood in 2012.....	405
Table 7.2:	Environmental impact of the different methods of smoke generation	413
Table 7.3:	Environmental impact of processes of the fish processing industry	414

Table 7.4:	Inputs and outputs of different types of fish production (per 1 000 kg of fish).....	415
Table 7.5:	Specific water consumption and organic load in Nordic countries	416
Table 7.6:	Waste water characteristics from fish filleting	417
Table 7.7:	Characteristics of untreated fish industry waste water and primary treatment efficiencies	418
Table 7.8:	Typical waste water production rates and characteristics for fish processing in Germany	418
Table 7.9:	Discharge data before and after introduction of dry removal and transport of viscera	424
Table 7.10:	Odour reduction using non-thermal plasma treatment	428
Table 7.11:	Technical data of a direct flame thermal oxidiser applied in a smokehouse	428
Table 7.12:	Technical data for a direct flame thermal oxidiser applied in a smokehouse	430
Table 7.13:	Periodic measurements of TVOC emissions to air from a smoke kiln after thermal oxidation.....	431
Table 7.14:	Periodic measurements of TVOC emissions to air from a smoke kiln after wet scrubbing	431
Table 8.1:	Summary of the possible processing routes of some fruit and vegetables	434
Table 8.2:	Energy carriers and consumption for steam peeling, prior to freezing vegetables	436
Table 8.3:	The effect of a combination of abrasion pre-peeling and knife peeling on water pollution loads in the production of half pears in syrup	438
Table 8.4:	The effect of caustic peeling on water pollution in the production of half pears in syrup	440
Table 8.5:	Energy carriers and consumption for caustic peeling, prior to freezing vegetables	440
Table 8.6:	Energy carriers and consumption for a belt blancher with water cooling	442
Table 8.7:	Energy carriers and consumption for a belt blancher with air cooling	443
Table 8.8:	Energy carriers and order of magnitude indicators of the drum blancher	444
Table 8.9:	Energy carriers and consumption for countercurrent drum water cooling	444
Table 8.10:	Water consumption for some processes in the fruit and vegetable sector	452
Table 8.11:	Emissions to water from potato processing	454
Table 8.12:	Emissions to water from fruit and vegetable processing	454
Table 8.13:	Waste water values of brine during the production of sauerkraut	458
Table 8.14:	Electricity consumption during the sorting of vegetables	458
Table 8.15:	Energy carriers and consumption for the caustic peeling of vegetables	458
Table 8.16:	Energy carriers and consumption for the steam peeling of vegetables.....	459
Table 9.1:	Total dust emissions to air from the grain milling process after treatment in a bag filter (dry basis).....	478
Table 9.2:	Total dust emissions to air from the grain milling process after treatment in a cyclone (dry basis).....	479
Table 10.1:	Typical processes applied in FDM meat processing installations	484
Table 10.2:	General overview of processes applied for different meat products	489
Table 10.3:	Potential environmental effects of typical processes applied in meat processing installations	494
Table 10.4:	Reported TVOC emission data from smoke kilns (spot samples, concentrations).....	501
Table 10.5:	Average values of periodic measurements of TVOC emissions to air from a smoke kiln after thermal oxidation	504
Table 10.6:	Additional data of periodic measurements of TVOC emissions to air from a smoke kiln after thermal oxidation	506
Table 10.7:	Data of periodic measurements of TVOC emissions to air from a smoke kiln after wet scrubbing	507
Table 11.1:	Energy data of an alkaline closed-circuit system	520
Table 11.2:	Performance data of an example DC system.....	521
Table 11.3:	Energy data of a double scrubber combined with a once-through cooling system.....	523
Table 11.4:	Summary of key solid/liquid emissions and by-products in the manufacturing of crude vegetable oils.....	528
Table 11.5:	Indicative contribution of sources of hexane losses during oilseed processing.....	533
Table 11.6:	Total dust emissions to air from seed handling, preparation and drying after treatment in a bag filter	536
Table 11.7:	Total dust emissions to air from seed handling, preparation and drying after treatment in a cyclone	538
Table 11.8:	Dust emissions to air from seed handling preparation and drying after treatment in a wet scrubber (dry basis)	539
Table 11.9:	Average values of periodic measurements of dust emissions from the drying and cooling of meal after treatment in a cyclone (dry basis)	540
Table 11.10:	Energy consumption data for the DT and downstream drying operation in oilseed extraction.....	545
Table 12.1:	Comparison of throughputs for the three-phase and two-phase olive oil processes.....	554
Table 12.2:	Comparison of treatment alternatives for olive oil waste water	555
Table 12.3:	Characteristics of olive oil mill waste water	556

Table 12.4:	Volumes of olive oil waste waters from the two- and three-phase extraction processes ...	557
Table 12.5:	Compositon of olive oil waste waters from the two- and three-phase extraction processes	557
Table 13.1:	Comparison of heat treatment processes for pasteurisation	570
Table 14.1:	Characteristics of starch sector waste water after treatment	577
Table 14.2:	Total dust emissions to air from preparation of raw materials (dry basis)	582
Table 14.3:	Concentration of potato starch process water by evaporation – design data	586
Table 14.4:	Biological waste water treatment characteristics in a potato starch installation	586
Table 14.5:	Total dust emissions to air from a dryer after treatment in a bag filter	588
Table 14.6:	Total dust emissions to air from a dryer after treatment in a cyclone	589
Table 14.7:	Total dust emissions to air from a dryer after treatment in a wet scrubber	591
Table 14.8:	Total dust emissions to air from raw material preparation after treatment in a bag filter (dry basis)	592
Table 15.1:	Average TVOC emissions to air from a beet pulp dryer (spot sampling)	603
Table 15.2:	Characteristic LTD and HTD of sugar beet pulp	614
Table 15.3:	Total dust emissions to air from a beet pulp dryer after treatment in a cyclone	619
Table 15.4:	Total dust emissions to air from a beet pulp dryer after treatment in a wet scrubber	620
Table 15.5:	Average values of periodic measurements of TVOC emissions to air from a beet pulp dryer after treatment in a wet scrubber (dry basis)	622
Table 15.6:	Average values of periodic measurements of SO _x emissions to air from a beet pulp dryer after treatment in a wet scrubber (dry basis)	622
Table 15.7:	Average values of continuous measurements of SO ₂ emissions to air from a beet pulp dryer after treatment in a wet scrubber	622
Table 15.8:	Average values of periodic measurements of SO _x emissions to air from a beet pulp dryer	623
Table 16.1:	Why and how coffee beans change during the roasting process	631
Table 16.2:	Solvent decaffeination process	634
Table 16.3:	Water decaffeination process	634
Table 16.4:	Solid wastes and by-products in the citric acid fermentation process	647
Table 16.5:	Treated waste water pollutant levels per tonne of installed production capacity in citric acid fermentation	647
Table 17.1:	BAT-associated emission levels (BAT-AELs) for direct emissions to a receiving water body	669
Table 17.2:	Indicative environmental performance levels for specific energy consumption	672
Table 17.3:	Indicative environmental performance level for specific waste water discharge	673
Table 17.4:	BAT-associated emission levels (BAT-AELs) for channelled dust emissions to air from grinding and pellet cooling in compound feed manufacture	673
Table 17.5:	Indicative environmental performance level for specific energy consumption	674
Table 17.6:	Indicative environmental performance level for specific waste water discharge	674
Table 17.7:	BAT-associated emission levels (BAT-AELs) for channelled dust emissions to air from handling and processing of malt and adjuncts	675
Table 17.8:	Indicative environmental performance levels for specific energy consumption	676
Table 17.9:	Indicative environmental performance levels for specific waste water discharge	677
Table 17.10:	BAT-associated emission level (BAT-AEL) for channelled dust emissions to air from drying	678
Table 17.11:	BAT-associated emission level (BAT-AEL) for channelled TVOC emissions to air from a smoke chamber	681
Table 17.12:	Indicative environmental performance levels for specific energy consumption	682
Table 17.13:	Indicative environmental performance levels for specific waste water discharge	682
Table 17.14:	Indicative environmental performance level for specific energy consumption	683
Table 17.15:	BAT-associated emission level (BAT-AEL) for channelled dust emissions to air from grain milling	683
Table 17.16:	Indicative environmental performance level for specific energy consumption	684
Table 17.17:	Indicative environmental performance level for specific waste water discharge	684
Table 17.18:	BAT-associated emission level (BAT-AEL) for channelled TVOC emissions to air from a smoke chamber	685
Table 17.19:	Indicative environmental performance levels for specific energy consumption	686
Table 17.20:	Indicative environmental performance levels for specific waste water discharge	686
Table 17.21:	BAT-associated emission levels (BAT-AELs) for channelled dust emissions to air from handling and preparation of seeds as well as drying and cooling of meal	687
Table 17.22:	BAT-associated emission levels (BAT-AELs) for hexane losses from oilseed processing and refining	688
Table 17.23:	Indicative environmental performance level for specific energy consumption	689

Table 17.24: Indicative environmental performance level for specific waste water discharge	689
Table 17.25: Indicative environmental performance levels for specific energy consumption	690
Table 17.26: Indicative environmental performance levels for specific waste water discharge.....	690
Table 17.27: BAT-associated emission levels (BAT-AELs) for channelled dust emissions to air from starch, protein and fibre drying	691
Table 17.28: Indicative environmental performance level for specific energy consumption.....	692
Table 17.29: Indicative environmental performance level for specific waste water discharge	692
Table 17.30: BAT-associated emission level (BAT-AEL) for channelled dust emissions to air from beet pulp drying in the case of high-temperature drying (above 500 °C).....	693
Table 17.31: BAT-associated emission level (BAT-AEL) for channelled SO _x emissions to air from beet pulp drying in the case of high-temperature drying (above 500 °C) when natural gas is not used	694
Table 18.1: Key milestones of the FDM review process.....	697
Table 18.2: Split views.....	698
Table 19.1: List of installations that participated in the FDM data collection.....	701
Table 19.2: Examples of heat treatment combinations used in the FDM sector	743
Table 19.3: Typical total solids concentrations for various types of evaporators.....	745
Table 19.4: Typical freezing points of various FDM products.....	749

SCOPE

This BAT reference document (BREF) concerns the following activities specified in Sections 6.4 (b) and (c) of Annex I to Directive 2010/75/EU, namely:

- 6.4 (b) Treatment and processing, other than exclusively packaging, of the following raw materials, whether previously processed or unprocessed, intended for the production of food or feed from:
 - (i) only animal raw materials (other than exclusively milk) with a finished product production capacity greater than 75 tonnes per day;
 - (ii) only vegetable raw materials with a finished product production capacity greater than 300 tonnes per day or 600 tonnes per day where the installation operates for a period of no more than 90 consecutive days in any year;
 - (iii) animal and vegetable raw materials, both in combined and separate products, with a finished product production capacity in tonnes per day greater than:
 - 75 if A is equal to 10 or more; or
 - $[300 - (22.5 \times A)]$ in any other case,
 where 'A' is the portion of animal material (in percent of weight) of the finished product production capacity.

Packaging shall not be included in the final weight of the product.

This subsection shall not apply where the raw material is milk only.

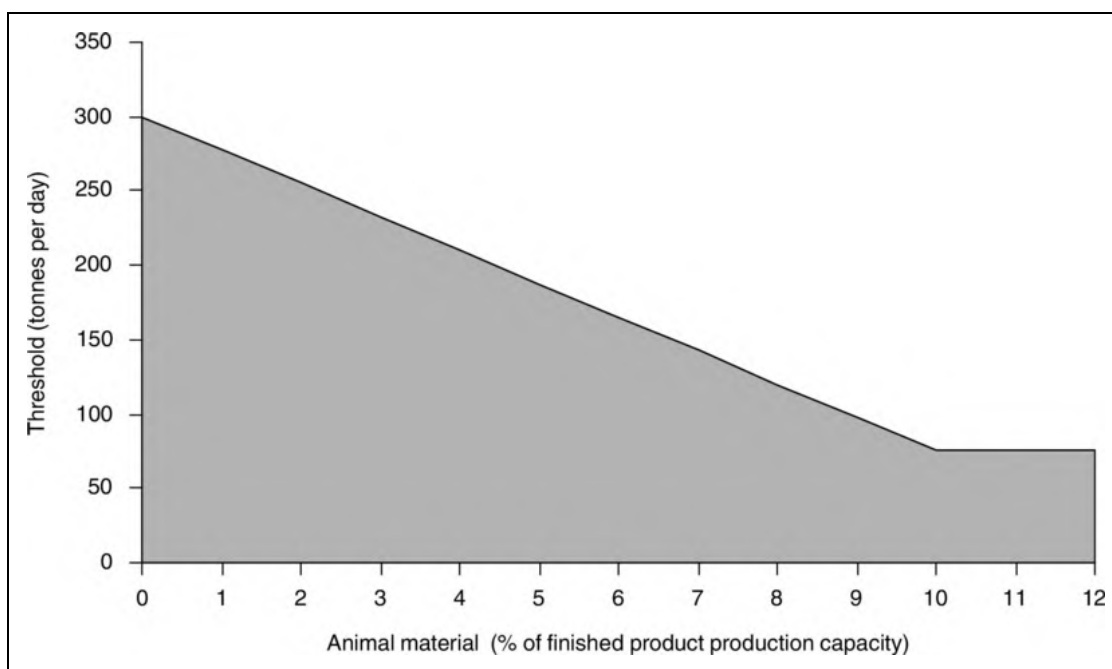

- 6.4 (c) Treatment and processing of milk only, the quantity of milk received being greater than 200 tonnes per day (average value on an annual basis).
- 6.11 Independently operated treatment of waste water not covered by Directive 91/271/EEC provided that the main pollutant load originates from activities specified in Sections 6.4 (b) or (c) of Annex I to Directive 2010/75/EU.

This document also covers:

- the combined treatment of waste water from different origins provided that the main pollutant load originates from the activities specified in Sections 6.4 (b) or 6.4 (c) of Annex I to Directive 2010/75/EU and that the waste water treatment is not covered by Directive 91/271/EEC²;
- the production of ethanol taking place on an installation covered by the activity description in 6.4 (b) (ii) of Annex I to Directive 2010/75/EU or as a directly associated activity to such an installation.

This document does not address the following:

- On-site combustion plants generating hot gases that are not used for direct contact heating, drying or any other treatment of objects or materials. This may be covered by the BAT conclusions for Large Combustion Plants (LCP) or by Directive (EU) 2015/2193 of the European Parliament and of the Council³.
- Production of primary products from animal by-products, such as rendering and fat melting, fishmeal and fish oil production, blood processing and gelatine manufacturing. This may be covered by the BAT conclusions for Slaughterhouses and Animal By-products Industries (SA).
- The making of standard cuts for large animals and cuts for poultry. This may be covered by the BAT conclusions for Slaughterhouses and Animal By-products Industries (SA).

Other BAT conclusions and reference documents which could be relevant for the activities covered by this BREF include the following:

- Large Combustion Plants (LCP);
- Slaughterhouses and Animal By-products Industries (SA);
- Common Waste Water and Waste Gas Treatment/Management Systems in the Chemical Sector (CWW);
- Large Volume Organic Chemical Industry (LVOC);
- Waste Treatment (WT);
- Production of Cement, Lime and Magnesium Oxide (CLM);
- Monitoring of emissions to Air and Water from IED Installations (ROM);
- Economics and Cross-Media Effects (ECM);
- Emissions from Storage (EFS);
- Energy Efficiency (ENE);
- Industrial Cooling Systems (ICS).

The scope of this document does not include matters that only concern safety in the workplace or the safety of products because these matters are not covered by the Directive. They are discussed only where they affect matters within the scope of the Directive.

² Council Directive 91/271/EEC of 21 May 1991 concerning urban waste-water treatment (OJ L 135, 30.5.1991, p. 40).

³ Directive (EU) 2015/2193 of the European Parliament and of the Council of 25 November 2015 on the limitation of emissions of certain pollutants into the air from medium combustion plants (OJ L 313, 28.11.2015, p. 1).

1 GENERAL INFORMATION ABOUT THE FDM SECTOR

1.1 Description, turnover, growth, employment

The FDM sector produces both finished products destined for consumption and intermediate products destined for further processing.

Europe's food and drink industry had an annual turnover of EUR 1 039 billion and generated 4.42 million jobs in 2016, making it the largest manufacturing industry in the EU-28 that year. This represented 14.6 % of the total manufacturing sector turnover and 14.5 % of the total manufacturing sector employment in the EU-28. The industry is highly fragmented with over 287 000 companies, approximately 285 000 of which are small and medium-sized enterprises (SMEs), which account for almost half of the total industry turnover and two thirds of overall industry employment. Europe's food manufacturing industry is also a local industry, using 70 % of agricultural raw materials produced in the EU, which helps generate jobs both up and downstream in communities throughout the European Union. Data from Member States in the EU-28 are presented in Table 1.1 and in Table 1.2.

Table 1.1: Structure and production of the food and drink industry by Member State in the EU-28

Member State	Turnover (million EUR)	Number of persons employed	Number of enterprises	Exports (million EUR)	Imports (million EUR)
Austria	21 614	80 536	3 818	2 154	1 385
Belgium	45 872	95 843	6 984	4 473	5 928
Bulgaria	4 921	94 342	5 834	1 142	404
Croatia	5211	62 909	3 240	606	444
Cyprus	1 409	11 677	886	120	151
Czechia	13 835	113 062	8 432	472	410
Denmark	25 746	62 504	1 575	4 607	3 173
Estonia	1 778	14 369	490	376	88
Finland	11 283	39 374	1 737	712	703
France	182 821	624 357	60 603	19 516	8 875
Germany	193 159	867 495	29 635	12 981	13 631
Greece	13 423	86 979	15 429	1 178	946
Hungary	11 396	102 261	6 625	973	269
Ireland	NA	NA	NA	2 499	914
Italy	128 342	428 601	57 640	9 615	8 035
Latvia	1 894	25 653	968	1 001	225
Lithuania	4 144	42 128	1 489	2 165	447
Luxembourg	884	5 457	162	39	80
Malta	NA	3 696	397	187	59
Poland	69 301	126 096	5 587	135 84	15 769
Portugal	55 191	404 963	12 631	4 120	2 150
Romania	14 960	102 670	10 649	1 490	1 551
Slovakia	11 216	184 476	8 566	1 889	755
Slovenia	4 462	37 242	2 766	109	95
Spain	2 137	16 007	1 940	318	636
Sweden	103 249	355 262	27 119	7 395	8 961
The Netherlands	19 584	63 242	3 820	1 970	4 357
United Kingdom	91 331	368 140	8 230	8 732	13 170
EU-28	1 039 159	4 419 341	287 252	104 421	93 612
NB: NA = not available. Source: [176, Eurostat 2016]					

Table 1.2: Structure and production of some food and drink sectors in the EU-28

	Production		Added value		Employees	
	Million EUR	%	Million EUR	%	Number	%
Processing and preserving of meat and production of meat products	207 683	24.7	30 577	18.3	886 000	22.7
Processing and preserving of fish, crustaceans and molluscs	23 630	2.8	4 208	2.5	114 300	2.9
Processing and preserving of fruit and vegetables	60 425	7.2	13 177	7.9	249 700	6.4
Manufacture of vegetable and animal oils and fats	45 243	5.4	4 258	2.5	56 700	1.5
Manufacture of dairy products	140 000	16.7	20 000	11.9	NA	NA
Manufacture of grain mill products, starches and starch products	43 379	5.2	7 273	4.3	101 300	2.6
Manufacture of bakery and farinaceous products	107 411	12.8	40 281	24.0	1 350 200	34.6
Manufacture of other food products	NA	NA	NA	NA	600 000	15.4
Manufacture of prepared animal feeds	70 000	8.3	10 100	6.0	122 000	3.1
Manufacture of beverages	142 801	17.0	37 636	22.5	425 900	10.9
Total	840 572	100	167 513	100	3 906 100	100
NB: NA = not available. Source: [176, Eurostat 2016]						

1.2 Sector structure

Available statistics show that the EU-28 FDM sector comprises close to 287 000 companies, around 90 % of which have 20 employees or less. The food and drink industry is the top employment sector in the EU (14.5 %) and leading employer in the manufacturing sector in more than half of the EU Member States.

The EU-28 FDM sector is exceptionally diverse compared to many other industrial sectors. This diversity can be seen in terms of the size and nature of companies; the wide range of raw materials, products and processes and the numerous combinations of each, and the production of homogenised global products as well as numerous specialist or traditional products on national and even regional scales. The sector is also subject to very diverse local economic, social and environmental conditions, and varying national legislation.

The EU-28 FDM industry is quite fragmented. Approximately 92 % of the sector is made up of SMEs, although there are some sectors, such as sugar manufacturing, which have very large companies. Approximately 70 % of the agricultural raw materials used by the industry are produced in the EU, which helps generate jobs both up and downstream in rural and urban communities throughout the European Union. This fragmentation and diversity, as well as divergent data collection systems in individual MS, makes it difficult to ascertain exact figures for the sector as a whole. Based on data submitted by Member States during 2012–2013, information on the number of installations specified in Sections 6.4 (b) and (c) of Annex I to the IED Directive is given in Table 1.3.

Table 1.3: Summary of existing FDM installations requiring a permit by activity category in Annex I to Directive 2010/75/EU (reference period 2012–2013)

Member State	6.4 (b)	6.4 (c)	Total
Austria	12	10	22
Belgium	58	16	74
Bulgaria	8	0	8
Croatia	NA	NA	NA
Cyprus	NA	NA	NA
Czechia	74	18	92
Denmark	38	20	58
Estonia	1	3	4
Finland	16	13	29
France	384	199	583
Germany	285	121	406
Greece	36	7	43
Hungary	21	4	25
Ireland	14	24	38
Italy	259	32	291
Latvia	NA	5	5
Lithuania	NA	NA	NA
Luxembourg	NA	1	1
Malta	NA	NA	NA
Poland	136	45	181
Portugal	60	10	70
Romania	22	2	24
Slovakia	13	3	16
Slovenia	4	2	6
Spain	292	40	332
Sweden	20	17	37
The Netherlands	94	31	125
United Kingdom	287	56	343
EU-28	2134	678	2812
NB: ; NA = not available.			
Source: [177, COM 2016] [2, IED Forum 2018]			

The sector is spread all over Europe, in very industrialised regions as well as in rural areas. Traditionally, industrial production has been closely related to primary production, climate and natural resources, e.g. land and water, along with the actual requirements of the particular production technique. These significantly influence the structure and geographical location of specific industrial production. Although this kind of dependence is being reduced, it still holds true in many sectors. For example, some sectors are still concentrated in special regions, e.g. fish processing is usually found in countries or regions which have direct access to the sea and traditions of fishing, and olive oil is mainly manufactured in Mediterranean countries, especially in Andalusia in Spain. Other activities such as sugar production/refining, grain milling and dairy industries are found in all countries. Some FDM production activities have special requirements with regards to natural resources, such as the need for a receiving water body for the discharge of large volumes of treated waste water. Sugar- and starch-producing installations, oilseeds installations and oil refineries and fruit and vegetable preservation installations are normally situated near water for this reason.

1.3 Trade

For many companies, exporting their product out of Europe is an important part of their business. In the first semester of 2013, the EU-28 FDM sector exports amounted to EUR 42 400 million. This is a 4 % increase compared to 2012 figures.

The main export market for European FDM products is the US. The Chinese, Japanese, Swiss and Russian markets are also significant. The top export destinations of EU-28 FDM products in 2014, in financial terms, are shown in Table 1.4. The origins of the top imports to the EU-28 are shown in Table 1.5.

Table 1.4: Top export destinations of EU-28 FDM products in 2014

Export destination	Million EUR
USA	14 566
Russia	6 335
China	5 583
Switzerland	5 304
Japan	4 607
Hong Kong	3 662
Norway	3 146
Canada	2 592
Australia	2 348
Saudi Arabia	2 219
<i>Source: [176, Eurostat 2016]</i>	

Table 1.5: Origins of top imports of non-EU FDM products in 2014

Import origin	Million EUR
Brazil	6 706
USA	4 853
Argentina	4 341
Switzerland	4 137
China	3 655
India	3 647
Thailand	2 549
Turkey	2 505
Norway	1 989
Malaysia	1 765
<i>Source: [176, Eurostat 2016]</i>	

The top individual export sectors in the FDM sector in 2014 are shown in Table 1.6.

Table 1.6: Exports by sector in the EU-28 in 2014

Sector	Million EUR
Drinks, of which:	25 706
spirits	10 176
wine	8 867
mineral water and soft drinks	2 761
Chocolate and confectionery	5 235
Processed tea and coffee	2 111
Meat products	11 249
Dairy products	9 488
Fruit and vegetable products	4 981
Oils and fats	4 538
Prepared animal feeds	2 883
Bakery and farinaceous products	3 498
Fish and sea food products	3 419
Grain mill products and starch products	2 828
<i>Source: [176, Eurostat 2016]</i>	

The UN predicts that the world population will reach 9 billion in 2050 and will require 70 % more food production. This will necessarily lead to an increased demand for food, drink and milk products and production. The European food and drink industry is faced with the twin challenges of ensuring access to raw materials at competitive prices and the sustainable supply of nutritious food against the backdrop of global food security.

1.4 Market forces: demand, distribution and competition

1.4.1 Demand

An ever-increasing number of social and economic factors affect FDM consumption patterns throughout the EU-28, leading to some diversification in consumption and purchasing. Greater homogeneity in lifestyles is reflected in the consumption and purchasing patterns for a growing variety of goods. The European food and drink industry is constantly responding to changing consumer demands by providing a wide range of food products. Even so, FDM products still retain elements of cultural specificity linked to national or regional traditions. So although consumers want to be able to purchase the same items and quality of products throughout the whole of the EU-28, they also demand the option/choice of different products linked to their own tradition or culture. This can be reflected at a national, regional or even more local level and can also vary throughout the year. For instance, for the feed industry, this impacts feed formulation through diverse feed specifications to allow livestock farmers to meet the requirements related to the quality of animal products, while ensuring their profitability and resource efficiency. Food and feed products may have different quality specifications (e.g. on taste, colour, texture) that require specific technologies.

1.4.2 Distribution

Cost control activities, e.g. labour-saving technologies, improvements in logistics and distribution channels and resource-saving practices, have been introduced. In general, most FDM products tend to be distributed to the major retail chains, although substantial differences persist between countries.

1.4.3 Competition

Even if great fragmentation still persists in most countries, the size and corresponding economic strength of companies is becoming crucial for balancing the increasing bargaining power of retailers and achieving the minimum critical mass in terms of production volumes.

1.5 The importance of food safety in FDM processing

As well as environmental considerations, there are other legal requirements and prohibitions which must be considered when identifying best available techniques in the FDM industry. There are specific requirements, for example relating to food safety, and these are updated from time to time. All FDM production installations, regardless of their size, geographical location or point in the production process, must comply with the required food safety standards.

The achievement of the required standards can be made easier if all of the operators with responsibilities collaborate closely. The FDM industry has identified five key areas that can ensure day-to-day food safety, i.e. improved food safety systems, robust traceability systems, crisis management, risk identification and communication. The application of such principles, in particular in relation to crisis management, risk identification and communication, should also be considered with respect to environmental protection. Where quality management systems have been developed from ISO 9001 *Quality System–Model for quality assurance in design/development, production, installation and servicing*, and ISO 22000 *Food Safety Management* for example, familiarity with such systems may facilitate the use of equivalent environmental standards-related systems.

Food safety laws may have an influence on environmental considerations. For example, food safety and hygiene requirements may affect the requirement for water use to clean the equipment and the installation, making it necessary to use hot water, so there are also energy considerations. Likewise, waste water is contaminated by substances used for hygiene purposes, for cleaning and sterilisation, e.g. during the production and packaging of long-life FDM products. Heat treatment is a key tool to manage microbiological contamination of feed and is even mandatory under many countries' national legislation. These issues have to be considered to ensure that hygiene standards are maintained, but taking into account the control of water, energy, and detergent and steriliser use. Cooling is another parameter relevant to maintenance of hygiene requirements and food safety that will also have a significant impact on energy consumption.

1.6 Legislative framework for food, drink and milk products

Protection of the consumer and of the environment, and the elimination of obstacles to the free movement of goods are among the main concerns of EU FDM legislation. The EU legislative framework is based on horizontal measures across product categories as well as on commodity-specific so-called vertical measures, derived from agricultural policy or the agri-monetary system.

As well as the general legislation, e.g. financial, environmental, health and safety, the FDM sector is also controlled by specific very detailed and comprehensive legislation starting at the farm gate and ending on the dinner plate. This legislation covers the following main areas:

- food and feed safety (contaminants, pesticide residues, quality of water intended for food consumption, official control of foodstuffs, materials in contact with foodstuffs);
- food and feed hygiene (general rules, health rules concerning foodstuffs of animal origin);
- food and feed composition (additives, flavourings, processing aids, genetically modified organisms);
- consumer information (general labelling rules, quantitative ingredient declaration, lot identification, unit pricing);
- food and feed nutrition, food and feed labelling;
- animal by-products;
- ionisation;
- organic production.

Section 1.7 refers to some selected legislation on the environment. Other pieces of environmental legislation are also valid for the industry, e.g. Council Directive 98/83/EC on the quality of water for human consumption.

1.7 The FDM sector and the environment

The FDM sector often depends on the quality of natural resources, especially that of land and water, so preserving the environment in which the raw materials are grown is very important. The level of pollution in waste water and the amount of waste produced by the industry can represent a significant load in some countries or regions. While most emissions from the industry are biodegradable, some sectors use materials such as salt or brine which are resistant to conventional treatment methods.

The trigger for the sector to improve its environmental performance has therefore been based on efficiency improvements, e.g. maximising the utilisation of materials, which subsequently leads to a minimisation of waste. Food wastage represents a major waste of resources and a needless source of greenhouse gas emissions that impacts climate change. There are also negative economic consequences for everyone along the food chain when food goes to waste. For this reason, significant efforts have been made to reduce the amount of food wasted in the food and drink sector through different industry initiatives. In 2013, some food chain partners launched a joint effort to tackle the problem of food wastage via the publication of their 'Every Crumb Counts' Joint Declaration, aiming at maximising the food and feed use of inedible crop residues, inedible animal parts and by-products [[178, Every Crumb Counts 2015](#)].

The FDM industry focuses on proactive environmental management systems, natural resource conservation and the performance of waste minimisation techniques. To ensure sustainability, the effects of the raw material supply, food processing, transport, distribution, preparation, packaging and disposal must be considered and controlled. Both primary production and processing are critically dependent upon a reliable water supply and adequate water quality, in conformity with legal requirements.

The FDM sector complies with the requirements of the Directive 94/62/EC on packaging and packaging waste [[120, EC 1994](#)] by preventing the production of packaging waste, and by reuse and recycling as well as by recovery of packaging waste. Packaging is essential for complying with the food and drink products' strict hygienic standards and preserving their quality from production to consumption, which also helps to prevent and reduce food waste. It is also a marketing and sales tool and it conveys information like ingredients, nutrient content, cooking instructions and storage information.

Annex I to the Packaging and Packaging Waste Directive lays out the essential requirements on the composition and the reusable and recoverable (including recyclable) nature of packaging. The essential requirements, along with their associated CEN standards, are the leading set of legally binding EU design requirements for packaging. A list of CEN standards developed on packaging design can be found below:

- EN 13427: requirements for the use of European Standards in the field of packaging and packaging waste.
- EN 13428: requirements specific to manufacturing and composition - Prevention by source reduction.
- EN 13429: reuse.
- EN 13430: requirements for packaging recoverable by material recycling.
- EN 13431: requirements for packaging recoverable in the form of energy recovery, including specification of minimum inferior calorific value.
- EN 13432: requirements for packaging recoverable through composting and biodegradation.

These standards offer the required flexibility to encourage innovation and enable packaging to be adapted to consumer needs. They can also be incorporated into the environmental and quality management systems within companies.

Many FDM companies have implemented an EMS and some are certified or in the process of being certified to ISO 14001 or the EU Eco-Management and Audit Scheme (EMAS). The FDM sector is one of the industrial sectors with the most EMAS-registered organisations [107, COM 2017], [179, COM 2015] (for further information see Section 2.3.1.1).

1.7.1 Key environmental issues

Being part of a diverse industrial sector, the different FDM sectors have different environmental issues and challenges. Although the paragraphs below streamline impacts throughout the FDM sector, subsequent chapters will therefore reflect these divergences in terms of relevant consumptions, emissions and subsequently BAT conclusions.

Water consumption is one of the key environmental issues for the FDM sector. Water, which is not used as an ingredient ultimately, appears in the waste water stream or is transformed into steam and emitted to air. Typically, untreated FDM waste water is high in both COD and BOD content. Emission levels can be 10–500 times higher than in domestic waste water. The TSS concentration varies from negligible to more than 100 g/l. Untreated waste water from some sectors, e.g. meat, fish, dairy and vegetable oil production, contains high concentrations of fats, oils and greases (FOG). Waste water from the FDM industry is, in most cases, biodegradable and hence can be treated together with domestic waste water or waste water from other industrial sectors (e.g. carbon source for denitrification or for biological phosphorus removal).

The FDM sector accounts for approximately 10 % of the industrial final energy consumption in the EU-28 [106, COM 2016]. Energy consumption is thus another key environmental issue.

The main air pollutants from FDM processes are dust and volatile organic compounds (VOC). Moreover, relevant amount of refrigerants containing halogens may be released.

Table 1.7 provides an overview of the key environmental issues agreed on at the kick-off meeting for the review of the FDM BREF across the 13 FDM sectors for which data were collected.

For the other sectors, described in Chapter 16, only general information was collected as agreed on at the kick-off meeting. These sectors mostly have a very limited number of installations in Europe within the scope of the FDM BREF.

Table 1.7: Key environmental issues for emissions to air and to water agreed on at the kick-off meeting for the review of the FDM BREF

Sectors for data collection	Key environmental issues		
	Emissions to water (direct discharge, indirect discharge, landspreading)		Emissions to air
	General parameters	Additional parameters	
Animal feed	TOC, COD, TSS, TN, TP	—	Total dust
Brewing		—	Total dust
Dairies		Chloride (Cl)	Total dust
Ethanol production		—	—
Fish and shellfish processing		Chloride (Cl)	TVOC
Fruit and vegetables		—	—
Grain milling		—	Total dust
Meat processing		—	TVOC
Oilseed processing and vegetable oil refining		—	Total dust, TVOC, hexane
Olive oil processing and refining		—	Total dust, TVOC
Soft drinks and nectar/juice made from concentrate		—	—
Starch production		—	Total dust
Sugar manufacturing		—	Total dust, TVOC, NO _x , SO ₂ , CO

NB: NA = not applicable.
Source [235, COM 2015]

The TWG also decided at the kick-off meeting to collect data for BOD and NH₄-N emissions to water. These parameters are useful to assess the abatement efficiency of the WWTP.

The main sources of solid waste output are inherent losses besides spillage, leakage, overflow, defects/returned products, and retained material that cannot freely drain to the next stage in the process.

2 GENERAL PROCESSES AND TECHNIQUES ACROSS THE FDM SECTOR

2.1 Applied processes and techniques across the FDM sector

2.1.1 Introduction

The most commonly used processing techniques and unit operations in the FDM sector are shown in Table 2.1. Some of these processing techniques are described in Annex II (Section 19.2) of this BREF, to avoid repetition throughout the document.

Table 2.1: The processing techniques and unit operations most commonly used in the FDM sector

Materials reception and preparation
Materials handling and storage
Sorting/screening, grading, dehulling, destemming/destalking and trimming
Peeling
Washing
Thawing
Size reduction, mixing and forming
Cutting, slicing, chopping, mincing, pulping and pressing
Mixing/blending, homogenisation and conching
Grinding/milling and crushing
Forming/moulding and extruding
Separation techniques
Extraction
Deionisation
Fining
Centrifugation and sedimentation
Filtration
Membrane separation
Crystallisation
Removal of free fatty acids by neutralisation
Bleaching
Deodorisation by steam stripping
Decolourisation
Distillation
Product processing technology
Soaking
Dissolving
Solubilisation/alkalising
Fermentation
Coagulation
Germination
Brining/curing and pickling
Smoking
Hardening
Sulphitation
Carbonatation
Carbonation
Coating/spraying/enrobing/agglomeration/encapsulation
Ageing
Heat processing
Melting
Blanching
Cooking and boiling

Baking
Roasting
Frying
Tempering
Pasteurisation, sterilisation and UHT processing
Concentration by heat
Evaporation (liquid to liquid)
Drying (liquid to solid)
Dehydration (solid to solid)
Processing by removal of heat
Cooling, chilling and cold stabilisation
Freezing
Freeze-drying/lyophilisation
Post-processing operations
Packing and filling
Gas flushing and storage under gas
Utility processes
Cleaning and disinfection
Energy generation and consumption
Water treatment
Vacuum generation
Refrigeration
Compressed air generation
<i>Source: [1, CIAA 2002]</i>

The raw materials used by the FDM sector are natural products, which may vary from season to season and from year to year. It may, therefore, be necessary to adapt production processes to accommodate the changes in characteristics of the raw materials.

To process a raw material into a product normally involves applying a range of processing techniques linked together into a production line.

Providing a detailed description of every process applied in the FDM sector is beyond the scope of this document.

2.1.2 Energy consumption

FDM manufacturing requires electrical and thermal energy for virtually every step of the process. Electricity is needed for lighting, for process control of the installation, for heating, for refrigeration and as the driving power for machinery. It is usually generated and supplied by utility companies. When steam and electricity are generated on site, the efficiency factor can be considerably higher.

Thermal energy is needed for heating processing lines and buildings. The heat generated by the combustion of fossil fuels is transferred to the consumers by means of heat transfer media, which, depending on the requirements, are steam, hot water, air or thermal oil.

The basic boiler/generator design generally consists of a combustion chamber, where fuel combustion takes place. The heat is initially transferred by radiation, followed by a tubular heat exchanger for heat transfer by convection. The hot gas and heat transfer media are separated from each other by a specially designed heat-exchange system. Thermal efficiencies of heat generators very much depend on the application and fuel type. Efficiencies, calculated on the basis of lowest calorific value, range from 75 % to 90 %. Some products are heated up by means of direct radiation with open flames or convection with directly heated process air. In this particular case, natural gas or extra-light fuel oil is burned.

On-site combined generation of heat and power (CHP) is a valuable alternative for FDM manufacturing processes for which heat and power loads are balanced. The following cogeneration concepts are used in the FDM sector: high-pressure steam boilers/steam turbine, gas turbines or gas engines or diesel generators with waste heat recovery for steam or hot water generation. The overall fuel utilisation factor of CHP systems exceeds 70 % and is typically about 85 %. Energy efficiency can be up to 90 % or 95 % when the exhaust gases from a waste heat recovery system, such as a steam boiler, are used for other drying purposes. A dryer uses the hot gases from a combustion plant for direct contact with the product to be dried (e.g. sugar beet pulp, green fodder, starch). A similar principle is used by a smoke kiln, which uses the hot gas to smoke and/or cook the product (e.g. meat, fish).

The fuel conversion efficiency greatly exceeds that of any design of a commercial power station, even the latest generation of combined cycle gas turbines, which can achieve a conversion efficiency of 55 %. Sometimes surplus electricity can be sold to other users. Natural gas and fuel oil are the most convenient fuels. However, a few installations still burn solid fuels such as coal or process wastes. The utilisation of process wastes can be a convenient and competitive source of energy, and additionally helps to reduce the cost of off-site waste disposal.

The high energy usage in the FDM industry allied to the rising cost and decreasing availability of fossil fuels means that alternative, long-term energy supplies must be investigated. The extent of electricity generation by the food industry itself is low, meaning that there is a big gap between its consumption and generation which could be filled, to some extent, by appropriate renewable energy recovery from wastes. Given the nature of the raw materials available, one technology which seems well suited to the FDM industry is anaerobic digestion, a process in which biodegradable material is broken down by microorganisms, in the absence of oxygen, to yield biogas (see Section 2.3.5.1) [131, Hall et al. 2012].

In the FDM sector, a number of common techniques are applied with the aim of reducing energy consumption. A summary is presented below. Most of these techniques are described in more detail in the ENE BREF [132, COM 2009].

The Carbon Trust initiative also introduces simple and straightforward opportunities for saving energy in the food and drink industry [22, Carbon Trust 2012].

2.1.2.1 General processing techniques

2.1.2.1.1 Combined heat and power generation

Combined heat and power (CHP) generation, also known as cogeneration, is a technique through which heat and electricity are produced in one single process. In-house combined generation of heat and power can be used in food manufacturing processes for which heat and power loads are balanced. For example, sugar manufacturing requires electrical and thermal energy in every step of the process. Electricity is needed for lighting, for installation process control, and as the driving power for machinery. Steam and hot water are needed for heating process vessels and buildings. For example, as the size of dairies increases, the amounts of thermal and electrical energy needed for evaporation/drying steps is growing, making CHP a feasible alternative.

2.1.2.1.2 Heat pumps for heat recovery

The working principle of a heat pump is based on heat transfer from a lower temperature to a higher temperature by aid of electrical power. For example, the recovery of heat from warm cooling water. The cooling water is cooled down and the heat can be used for heating another stream of water.

Heat pumps are generally only a good solution when the site energy recovery has been fully optimised and only low-grade heat remains [203, FEFAC 2015].

2.1.2.1.3 Use of permanent magnet synchronous motors

In the case of a permanent magnet synchronous (PMAC) motor, the rotor itself contains permanent magnet material, which is either surface-mounted to the rotor lamination stack or embedded within the rotor laminations. Electrical power is supplied through the stator windings. PMAC motors are more efficient due to the elimination of rotor conductor losses, lower resistance winding and flatter efficiency curve. Due to their synchronous operation, PMAC motors offer more precise speed control. PMAC motors provide a higher power density due to the higher magnetic flux compared to induction machines. Finally, PMAC motors generally operate at cooler temperatures, resulting in a longer lifetime [193, TWG 2015].

2.1.2.1.4 Electrical power supply

Public electrical power is supplied via high-voltage grids where the voltage and current vary in sine wave cycles at 50 Hz (in Europe) in three phases at 120 ° intervals. The voltage is high to minimise current losses in transmission. Depending on the equipment used, the voltage is stepped down on entering the site, or close to specific equipment, usually to 440 V for industrial use, and 240 V for offices, etc.

Various factors affect the delivery and the use of energy, including the resistance in the delivery systems, and the effects some equipment and uses have on the supply. Stable voltages and undistorted waveforms are highly desirable in power systems.

If the power factor is corrected, for example by installing a capacitor at the loading point, this totally or partially eliminates the reactive power draw at the power supply company.

Moreover, certain electrical equipment with non-linear loads causes harmonics in the supply (the addition of distortions in the sine wave). Examples of non-linear loads are rectifiers, some forms of electric lighting, electric arc furnaces, welding equipment, switched mode power supplies, computers, etc. [132, COM 2009].

2.1.2.2 Techniques related to cooling/freezing

The typical cooling processes applied in the FDM sector are presented in Table 2.2. It should be noted that the selection of cooling agents and refrigerants is influenced by Regulation (EC) No 1005/2009 [118, COM 2009] and Regulation (EU) No 517/2014 [137, EC 2014].

Table 2.2: Typical cooling processes in the FDM sector

Cooling of products	Brief description / application examples
Cooling with air	
Blast cooling, batch cooling	Batch cooling in dedicated chilling rooms or cabinets. Cooling of unpacked or packed products.
Spiral cooling	Continuous cooling in dedicated equipment. Air speed of approximately 6 m/s. Cooling of unpacked or packed products.
Impingement cooling	Continuous cooling in dedicated equipment. Air speed of approximately 20–30 m/s. Cooling primarily of unpacked products.
Cooling with water	
Water spray	Spraying of water directly at the product. Cooling of unpacked or packed products.
Immersion in water (spin chiller)	Products immersed in chilled water, e.g. spin chiller. Cooling of unpacked or packed products.
Brine cooling (superchill)	Products immersed in brine superchill to -3°C . Cooling of packed products.
Ice, flake ice	Addition of flake ice to the product during the process to reach the optimal product temperature.
Cooling with air and water	
Evaporative cooling	Alternating addition of water spray and air to exploit both the media temperature and the heat used for vaporisation of the water. Cooling of unpacked and packed products.
Cooling with cryogenic gases	
Liquid CO ₂	Continuous or batch process. Shell freezing before slicing of products. Freezing of unpacked products.
CO ₂ pellets	Addition of CO ₂ pellets to the product. Post-chilling of products.
<i>Source: [220, Clitravi-Avec 2016]</i>	

Table 2.3 shows the typical freezing processes applied in the FDM sector. For more information about freezing see Section 19.2.6.1.

Table 2.3: Typical freezing processes in the FDM sector

Freezing of products	Brief description / application examples
Freezing with air	
Blast freezing	Batch freezing in cabinets. Packed products.
Spiral freezing	Continuous freezing system. Air speed of approximately 3–6 m/s. Freezing of unpacked or packed products.
Impingement freezing	Continuous freezing system. Air speed of approximately 20–30 m/s. Freezing of unpacked products.
Contact freezing, plate freezing	
Plate freezing	Batch freezing. Direct contact between product and evaporator. Freezing of packed or unpacked products.
Freezing with cryogenic gases	
Liquid CO ₂	Continuous or batch process. Shell freezing before slicing of products. Freezing of unpacked products.
<i>Source: [220, Clitravi-Avec 2016]</i>	

Further information on general techniques for cooling is available in the ICS BREF [162, COM 2001].

Major energy savings can be achieved in cooling and freezing. Savings are possible by correct adjustment of the working parameters, such as the evaporator temperature, conveyor belt speed and blower power in the freezing tunnel. These depend on the product being processed and the throughput. The consumption of energy in electrical systems in the freezing tunnel can be kept as low as possible by opting for frequency converters on the blowers, on the distributor conveyor and by installing high-efficiency low-energy lighting.

2.1.2.2.1 Heat recovery from cooling systems

Heat can be recovered from cooling equipment and compressors. This involves the use of heat exchangers and storage tanks for warm water. Depending on the cooling equipment, 50–60 °C temperatures can be achieved.

2.1.2.2.2 Use of high-efficiency motors for driving fans

The motors for driving the fans are set up in the freezing tunnel. The electrical energy supplied to the motors must, therefore, be dissipated by the freezer unit. By opting for high-efficiency motors for driving the fans, not only is there a direct saving in electricity, e.g. lower consumption by the fans, but also an indirect saving, e.g. through the lower cooling load on the refrigeration unit.

2.1.2.2.3 Dynamic cooling condensation control

Dynamic cooling condensation control is a programmable logic-control-based copyright system for condensation pressure optimisation. By monitoring the external temperature, atmospheric pressure and moisture, the system determines the best NH₃ (or other cooling gas used) condensation pressure value. Consequently, the NH₃ plant works between 8.5 bar and 11 bar, rather than 11 bar all the time, saving compressor energy.

By applying this process, the electric energy usage can be reduced by as much as 50 % [193, TWG 2015].

2.1.2.3 Techniques related to compressed air systems

2.1.2.3.1 Optimisation of the air inlet temperature

Compressors operate more efficiently using cool air. This is generally achieved by ensuring the air is taken from outside the building. This can be checked by measuring the dryer inlet temperature, which should not exceed 35 °C with the compressors on full load. The temperature of the dryer room should be within 5 °C of the outside ambient temperature. If the room temperature is too high, this lowers the compressor's performance [39, Environment Agency of England and Wales 2001].

2.1.3 Water consumption

A large part of the FDM sector cannot operate without a substantial amount of good quality water. In the FDM sector, hygiene and food safety standards have to be maintained. A systematic approach to control the use of water and reduce water consumption and its contamination is generally effective.

Each application of water requires its own specific quality. In the FDM sector, the quality requirements depend on whether or not contact between water and the food product is possible. Water that comes into contact with the product must, with a few exceptions, at least be of drinking water standard. Both chemical and microbiological quality aspects are important. It is advisable to conduct a regular check of the microbiological parameters of the water at the most critical places, i.e. at the point of use. This is normally incorporated in the hazard analysis critical control point system (HACCP). The quality standards for drinking water are laid down in Council Directive 98/83/EC [36, EC 1998].

The treatment required to produce water of a safe quality depends very much on the water source and its analysis. A minimum treatment concept involves water filtering, disinfecting and storage, but, depending on the water requirements, may also include de-ironing, desilication, or active carbon filtering. Treated drinking water is pumped from the storage tank and distributed through the installation pipe network to the users.

Additional treatment, such as softening, dealkalising, demineralising or chlorinating the water, is needed for usage in specific food processes or utilities. Ion exchangers or membrane filtration processes are the most common techniques used for this purpose.

The following sources of water are used in the FDM sector: tap water, groundwater, surface water, rainwater, and water originating from the raw material and reused water.

Tap water is distributed by a water main. The supplier is usually responsible for the quality of the water delivered and for checking the quality of the water regularly.

The composition of groundwater is generally reasonably constant and microbiological counts are mostly low, especially in deep boreholes. In most cases, little treatment is necessary before groundwater can be used as process water or cooling water. In most countries, a licence is needed for the extraction of groundwater. The quality of the groundwater is monitored by the user. Sometimes the authorities require notification of the results of regular water quality analyses.

Surface water cannot be used as process water unless it is treated first. When available, it is often used as cooling water. A licence may be required for such use.

Depending on the region, rainwater may be a source of water. This requires a storage basin. After appropriate treatment and control, rainwater may be used as process water, in open cooling systems.

Some raw materials that are processed in the FDM sector contain a considerable percentage of water as a liquid water phase, which can be separated from the solid constituents for separate utilisation. This separation can be carried out by, for example, pressing, centrifuging, evaporation or by using membrane techniques. Some examples are fruit juice, potato juice, sugar beet juice and milk. Such liquids can mostly be utilised if they are not used as a primary product. Sometimes they can be used without further treatment, e.g. condensate of the first stages of evaporators for boiler feed water, but otherwise appropriate treatment is necessary.

Reused water may come from chilled water, pump seal water, recovered condensate, or final cleaning rinses, etc.

2.1.3.1 Types of water consumption

Water is used in the FDM sector for:

- food processing, where the water either comes into contact with, or is added to, the product;
- equipment and installation cleaning;
- washing of raw materials;
- water which does not come into contact with the product, e.g. boilers, cooling circuits, refrigeration, chillers, air conditioning and heating, water used for product pasteurisation;
- cleaning of packaging materials;
- firefighting.

2.1.3.1.1 Process water

In the FDM sector, process water is used for direct preparation of products or other items which come into direct contact with the products, cleaning and disinfection, regeneration of water treatment equipment and for various technical purposes. Water that comes into contact with the product must, with a few exceptions, at least be of drinking water standard. For the production of soft drinks and beer, often special quality characteristics are required that sometimes exceed those of drinking water quality.

Examples of uses of process water that is used for direct preparation of products or other items which come into direct contact with the products include:

- starting up of continuous process lines such as in pasteurisers and evaporators;
- flushing out the product from the process equipment at the end of a production run;
- washing raw materials and products;
- wet transport, e.g. in a flume;
- dissolving ingredients;
- production of drinks;
- cooking in water bath or shower ovens.

Water of varying quality can be used for cleaning and disinfection purposes. The main steps involved in these processes are pre-rinsing with water, cleaning with cleaning agents, post-rinsing with water, and disinfection. Water is also needed for cleaning the outside of equipment, walls and floors. In this case, contact with the food product is unlikely, so drinking water quality is not required. However, often drinking water quality is used, to avoid any hazard.

Large quantities of process water for the regeneration of water treatment equipment are required for the removal of iron and/or manganese and for product softening and demineralisation. This water needs to be of a good quality, to prevent bacteriological contamination of the filter material and the need for the water to be treated afterwards. Furthermore, it is preferable for the water to have a low iron content and low hardness, to prevent rapid fouling and scaling of equipment.

Finally, process water is also used for other technical purposes, e.g. cooling water is used for pump seals, seal water for vacuum pumps and water in closed circuits for hot water systems and heat-exchange systems. Water is also used for air conditioning humidity control in storage areas and for processing raw materials. If there is a risk that, in the event of equipment failure, contact with the food product is possible, the water needs to be of drinking water quality.

2.1.3.1.2 Cooling water

Cooling water is the water used for the removal of heat from process streams and products. In the FDM sector, the cooling systems commonly applied are once-through cooling systems with no recirculation of cooling water, closed circulation cooling systems, open circulation cooling systems or cooling towers and cooling by direct contact with cooling water.

Cooling water is used in direct contact with food, e.g. after blanching of fruit and vegetables and for example to cool cans and glass bottles after sterilisation.

In open cooling systems, i.e. cooling towers, not only does evaporation of the water occur but also a small part of the water is sprayed. Furthermore, in a cooling tower the conditions for growth of *Legionella* bacteria are favourable. This means that the spray of cooling towers, if contaminated, may be a possible source of legionnaires' disease. To prevent the occurrence of legionnaires' disease, companies which operate these systems must comply with regulations requiring them to manage, maintain and treat them properly [101, Health and Safety Executive 2004]. Amongst other things, this means that the water must be treated and the system cleaned regularly. Air quality from cooling systems comes within the scope of the ICS BREF [162, COM 2001].

2.1.3.1.3 Boiler feed water

In the FDM sector, steam is generated using boilers with working pressures that can reach 120 bar. For power generation with steam turbines, higher steam pressures are needed. Steam is used for the sterilisation of tanks and pipelines. Another application is UHT treatment with direct steam injection. Sometimes steam injection is used for heating the product or for adjusting the water content of the raw material. In all these cases, some level of direct contact between steam and the food product is possible so drinking water quality is required.

Requirements generally depend on the working pressure and temperature of the boiler and the conductivity [38, CEOC 1984]. The higher the pressure and temperature, the higher the quality requirements are. This makes extensive water treatment necessary, e.g. removal of iron, softening and chemical conditioning. The quality of the boiler water is controlled by the quality of the boiler feed water. The frequency of boiler water blowdown also controls the quality.

It is important that boiler feed water does not cause scaling in the boiler or corrosion of the steam system. This means that boiler feed water has to have a very low hardness and be de-aerated. Returned condensate can also be used as boiler feed water supplemented by suitably treated make-up water.

2.1.3.1.4 Water recycling and reuse

In line with the EU Action Plan for the Circular Economy [180, COM 2015], recycling and reuse of process and waste water aims to improve the resource efficiency of the FDM sector. The potential role of treated waste water as an alternative source of water supply is now well acknowledged and embedded within European and national strategies.

The distinction between the concepts of recycling and reuse is made in the Waste Directive [59, WFD 98/EC 2008]. Reuse means any operation by which products or components that are not waste (e.g. process water) are used again for the same purpose for which they were conceived. Recycling means any recovery operation by which waste materials are reprocessed into products, materials or substances whether for the original or other purposes.

Consequently water reuse can be considered the reuse of water which is not waste water, whilst recycling is the use of waste water.

Depending on the local situation, there can be several types of water streams in a FDM installation. It can be divided into many sources according to its quality, e.g.:

- potable water;
- reused water from the process (e.g. from filtration of milk, from starch slurry);
- uncontaminated water and surface water that is not of drinking water quality;
- water recovered from treatment of waste water and from anaerobic digestion of waste (e.g. for landspreading).

When it is being decided which water sources can be reused and/or recycled in the installation, several issues might require consideration:

- Legal requirements related to food safety and hygiene.
- Customer requirements related to food safety, cleaning, etc.
- Product-related issues, e.g. distinguish between products that the consumer will use without further preparation and products that the consumer will prepare before eating.
- Risks related to water consumption. The installation might consider the possibility of monitoring the hygiene quality of the water to assess the risk of contamination of products. If contamination of products may occur, the installation might weigh up the benefits and disadvantages of reusing a certain water source.
- The consequences of reusing a specific water source, such as energy and chemical consumption for treatment of the water before reuse/recycling.
- Possible water shortage.

When looking at water consumption, it is not only the volume that should be taken into consideration. As most water used in the food industry will require some treatment, cooling and/or heating before use, the water consumption should be reduced as much as possible. This will also reduce energy use, e.g. for pumping and treatment. Moreover, both water shortage and excess of water at local level should be considered, where relevant. Different requirements on food safety and hygiene for products also have an influence on the water consumption. Additionally, the water quality itself can have an influence on how much water is needed for a specific use, e.g. for CIP.

All the aforementioned issues must be taken into consideration when evaluating the water consumption and considering water reuse and recycling in a specific installation [184, EDA 2016].

2.1.3.2 Cleaning and disinfection

Processing equipment and production installations are cleaned and disinfected periodically to comply with legal hygiene requirements. The frequency can vary considerably depending on the products and the processes. The aim of cleaning and disinfection is to remove product remnants, other contaminants and microorganisms.

Before starting the cleaning process, equipment is emptied as far as possible. Cleaning and disinfection can be carried out in various ways. Traditionally, it has been carried out manually. Cleaning-in-place (CIP), washing-in-place and, cleaning-out-of-place are all expressions used for different forms of cleaning. Cleaning agents are delivered in a variety of ways, for example in bags, e.g. powdered cleaning agents, or in drums or bulk tankers. Many cleaning agents are potentially hazardous to the health and safety of the operator and systems can be provided to minimise the risk during storage, handling, use and disposal.

CIP is used especially for closed process equipment and tanks, whether stationary or small mobile processing units. The cleaning solution is pumped through the equipment and distributed by sprayers in vessels, tanks and reactors. The cleaning programme is mostly run automatically,

and applies the following steps; pre-rinse with water, circulation with a cleaning solution, intermediate rinse, disinfection, and final rinse with water. In automatic CIP systems, the final rinse water is often reused for pre-rinsing or may be recycled/reused in the process. In CIP, high temperatures of up to 90 °C are used, together with strong cleaning agents. CIP systems used for open systems like freezers are almost entirely automatic, except for some dry clean-up and opening of hatches. Temperatures for medium-pressure systems are normally below 50 °C and the pressure is 10 bar to 15 bar.

Cleaning-out-of-place is used when several of the machine's components need to be dismantled, usually before the manual or automated cleaning of the machine is started. The dismantled components are cleaned separately outside the machine. Forming machines are one example of this. There are augers, pistons, valves, forming plates and seals which all have to be dismantled before cleaning the machine. High-pressure jet cleaning, using gels and foams, can be carried out manually or automatically. The appropriate cleaning method involves an appropriate combination of cleaning factors such as water, temperature of the cleaning solution, cleaning agents, i.e. chemicals, and mechanical forces. Only mild conditions, with regard to temperature and cleaning agents, can be used for manual cleaning.

High-pressure jet cleaning and foam cleaning are generally applied for open equipment, walls and floors. Water is sprayed onto the surface to be cleaned, usually at a pressure of about 40 bar to 65 bar. Cleaning agents are injected into the water, at moderate temperatures of up to 60 °C. An important part of the cleaning action takes place due to mechanical forces.

In foam cleaning, a foaming cleaning solution is sprayed onto the surface to be cleaned. The foam adheres to the surface. It stays on the surface for about 5 to 15 minutes and is then rinsed away with water. Foaming can be carried out both manually and automatically. Gel cleaning is similar to foam cleaning.

2.1.3.2.1 Selection of cleaning agents

In some cases, cleaning is undertaken using hot water only. However, this depends on the nature of the product and the process. Nevertheless, cleaning agents are normally used in the FDM sector. Cleaning agents are typically alkalis, i.e. sodium and potassium hydroxide, metasilicate and sodium carbonate; acids, i.e. nitric acid, phosphoric acid, citric acid and gluconic acid; composed cleaning agents containing chelating agents, i.e. EDTA, NTA, phosphates, polyphosphates; and phosphonates, surface-active agents, and/or enzymes. Disinfectants, such as hypochlorites, iodophors, hydrogen peroxide, peracetic acid and quaternary ammonium compounds, can be used.

The selection of the cleaning agents is dependent on several criteria, including the installation design, cleaning techniques available, type of soiling and nature of the production processes. Cleaning agents must be fit for purpose but other aspects are also important, e.g. gluconic acid is less corrosive than the other acids. Furthermore, cleaning in the FDM sector does not just mean the removal of impurities: disinfection is equally important.

The selection and use of cleaning and disinfection agents must ensure effective hygiene control but with due consideration of environmental implications [45, FoodDrinkEurope 2002]. When the use of cleaning agents is essential, it is necessary to first check that they can achieve an adequate level of hygiene and then to assess their potential environmental impact. The design of equipment for food processing also has a significant effect on the level of food security; a relevant consortium of equipment manufacturers, food industries, research institutes as well as public health authorities is the European Hygienic Engineering & Design Group.

Detergents are an important type of cleaning agents and are usually mixed with water before use. They can be divided into three broad groups, depending on the kind of solution they form: acidic, neutral or alkaline [205, Nordic Council of Ministers 2015].

Acid detergents are generally based on phosphoric or sulphuric acid, and their use is limited. They are extremely effective at removing salts precipitated from water in hard water areas, and at cleaning aluminium as the acids readily remove the white scale that forms on the surface of the metal.

Neutral detergents comprise a wide range of materials that are mainly suitable for light cleaning. They are generally similar to household detergents and their good wetting ability makes them ideal for the dispersal of grease and oil.

Alkaline detergents can vary in strength from those that are only a little stronger than the neutral types to ones that are strongly alkaline, consisting almost entirely of caustic soda, and requiring extreme care in use.

2.1.3.2.1.1 Selection of disinfectants and sterilisers

The chemicals used for disinfection and sterilisation of equipment and installations operate on the principle that they affect the cell structure within bacteria and prevent their replication.

The most commonly used sanitiser in food processing is chlorine, in its various forms. Commonly used chlorine compounds include liquid chlorine, hypochlorite, inorganic chloramines, and organic chloramines. Chlorine is active at low temperature, is relatively cheap, and leaves minimal residue or film on surfaces. The major disadvantage of chlorine compounds is the corrosive effect it has on many metal surfaces (especially at higher temperatures) [[205, Nordic Council of Ministers 2015](#)].

Several other types of treatment can also be applied. These involve the use of oxidising biocides, non-oxidising biocides, UV radiation and heat.

Non-oxidising biocides involve the use of, for example, quaternary ammonium salts, formaldehyde and glutaraldehyde. These are generally applied using a technique called fogging where the substance is sprayed into the area to be sterilised as a mist and allowed to coat the exposed surfaces. This is carried out between process shifts, so the fog has dispersed before the operator enters the work area. Exposure can cause respiratory problems, so occupational health needs to be considered when selecting and using disinfectants and sterilisers.

2.1.3.2.1.2 EDTA

EDTA (ethylenediaminetetraacetic acid) is the chelating agent used in the largest quantities. EDTA is mainly used due to its property as a chelating agent for calcium. In the dairy sector, the calcium content in milk is related to its protein content as calcium phosphocaseinate. EDTA may be used during CIP in dairies, as follows:

- To remove the calcium fouling, (also known as milkstone) which occurs on the stainless steel surfaces of milk processing machinery at temperatures from 70–80 °C. EDTA is used particularly on UHT equipment; membranes, e.g. ultrafiltration (UF) and reverse osmosis (RO) and for the preliminary cleaning of evaporators and spray dryers. Most of this fouling is made up of stable denatured proteins. These are destabilised using EDTA, which then enables the surface to be cleaned. Scale also builds up in other applications and it is reported that skilled operators can tell when a periodic clean is required to prevent this. The deposits are composed of proteins, minerals and fat.
- As a hardening stabiliser, to avoid precipitation of calcium when diluting concentrated alkaline detergents with water. High-temperature alkaline cleaning may leave a carbonate layer that could cause biofilm build up. In multiple-phase cleaning, alkaline cleaning is followed, after intermediate rinsing, by nitric acid cleaning. The acid cleaning leaves a shiny surface in contact with the product. Single-phase cleaning, using EDTA to capture the calcium ions contained in water, reduces this effect and removes the acid step.

- To bind calcium, magnesium and heavy metals to prevent sedimentation and incrustation, e.g. in the pipes and containers to be cleaned.
- The bactericidal activity of cleaning and disinfection agents, especially towards Gram-negative bacteria, increases when EDTA is incorporated, because of its ability to destroy the outer cell wall of these often resistant species.
- To improve the reuse of chemicals and to reduce water and energy consumption related to single-phase cleaning compared with two-phase cleaning with caustic and nitric acid.

EDTA forms very stable and water-soluble complexes which are not normally degraded in biological WWTPs, so the heavy metals remain in the waste water and not in the sludge, and they are discharged to surface water bodies. The EDTA can then also remobilise heavy metals from the sediment of rivers. Furthermore, nitrogen contained in EDTA may contribute to eutrophication of water. Many other chelating agents also contain either nitrogen or phosphorus.

Biological degradation of EDTA is slow and only proceeds under certain conditions, such as [67, Boehm et al. 2002] [68, Knepper et al. 2001]:

- long hydraulic retention time and sludge age;
- slightly alkaline conditions;
- a comparatively high EDTA concentration;
- EDTA should not be present as a heavy metal complex.

In addition, according to the draft risk assessment of 7 February 2003 under Regulation 793/93/EEC [111, COM 1993], EDTA causes a risk to the aquatic environment when used as a chelating agent in some industries. The predicted no-effect concentration in surface water bodies is 2.2 mg EDTA/l.

2.1.3.2.2 Sinner's circle

Sinner's circle is a model used to describe factors that influence the efficiency of a cleaning procedure. Sinner's circle describes the four main factors which influence cleaning efficiency. These four factors are cleaning time, temperature used, mechanics of cleaning and chemistry used. Ideally, these factors should influence the cleaning efficiency in equal parts, as is shown in Figure 2.1. But in fact, in most cases, Sinner's circle is composed differently because each factor's contribution to the cleaning efficiency varies [210, EDA 2016].

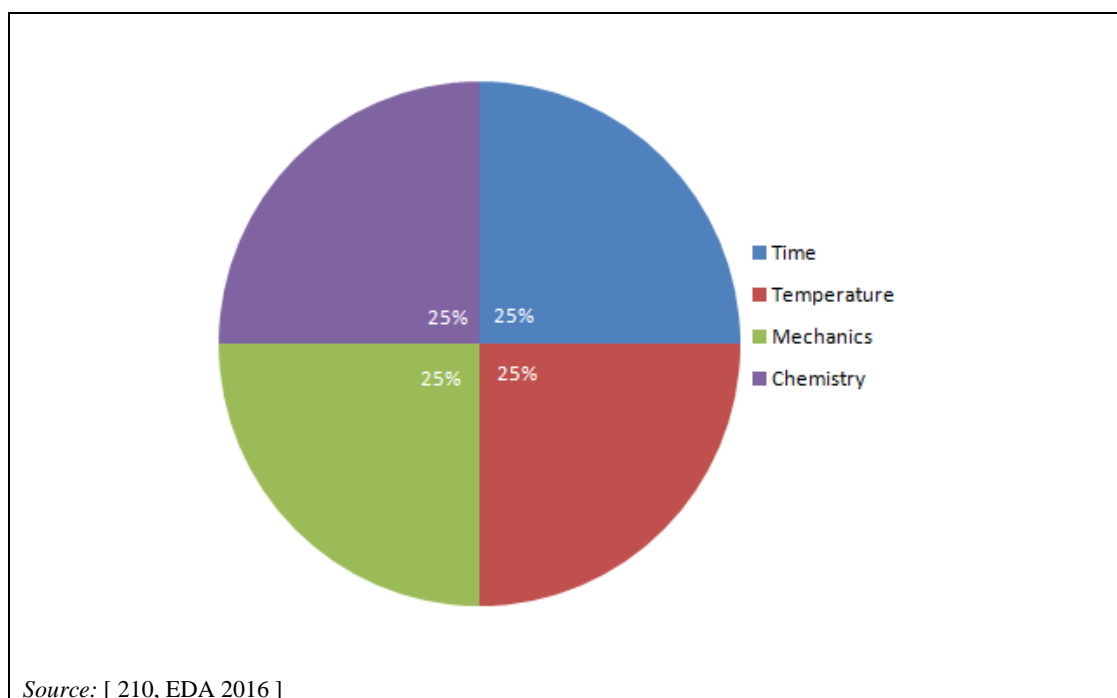

Figure 2.1: Ideal Sinner's circle

For example, mechanical forces exerting pressure on facility components may have a small influence on the cleaning efficiency of CIP cleaning of dairy facilities. This may be the case for example in pipes through which the production cycle's liquid components flow. For this reason, those mechanical forces do not contribute significantly to the cleaning process and the influence of added chemistry is much more important for cleaning efficiency. The cleaning temperature and time afforded for cleaning may contribute in equal parts.

How Sinner's circle is composed for the purpose of proving the cleaning efficiency is to be examined for each individual cleaning situation and is up to the company. Sinner's circle therefore provides a mathematical tool for calculating the proportion and intensity of each factor influencing cleaning efficiency.

2.1.4 Solid output

European estimations reveal that 70 % of EU food waste arises in the household, food service and retail sectors, with production and processing sectors contributing to the remaining 30 %. The EU Platform on Food Losses and Food Waste aims to support all actors in: defining measures needed to prevent food waste; sharing best practice; and evaluating progress made over time [127, COM 2016].

When heavily loaded waste water streams (high COD) are treated in an anaerobic waste water treatment unit, this results in a higher amount of biogas, but also a higher concentration of

recalcitrant COD. This COD will not be easily removed in the subsequent aerobic waste water treatment and will end up as emissions to water. Furthermore, in the case of intense reuse of water (e.g. reverse osmosis), the concentration of recalcitrant COD will increase. The reason why companies that do not have enough organic solid waste cannot install a digester is that a digester needs a constant feed. Small digesters do not deliver enough biogas to be profitable. Therefore it is recommended to reduce the load of solid materials to the anaerobic waste water treatment plant, and to send all collected solids to a digester. This can be achieved by:

- process-integrated techniques (e.g. preventing pulp, peels, etc. from ending up in the waste water);
- installing a sieve of at least 1.5 mm at the entrance of the anaerobic waste water treatment; problems, such as blocking of the sieve, occur when smaller sieves are used;
- installing a sedimentation unit at the entrance of the anaerobic waste water treatment [163, Belgium-VITO 2015].

In the anaerobic biological processes (anaerobic digestion), anaerobic bacteria convert part of the organic matter in the waste water into biogas. Temperature and pH conditions should be maintained within the optimum range. The technique could be generally applied at facilities where effluents with a high BOD/COD level are produced.

Generally, the biogas generated is a valuable source of renewable energy. Anaerobic digestion can be considered a sustainable method to manage organic waste. Furthermore, the overall energy requirement to treat waste water anaerobically is lower than that of aerobic treatment.

2.1.4.1 Packaging

The objective of packing is to use any products made of any materials of any nature for the containment, protection, handling, delivery and presentation of goods. Packing may be applied to raw materials and to processed goods. Filling is the process of putting the product in the package in a proper way.

The majority of food products are packaged before they enter the distribution chain. In some cases packing is an integral part of the production process, which means that the packaged product is further processed. An example of this is the canning and bottling of foods and subsequent heat conservation.

Most FDM products involve primary, secondary and tertiary packaging processes throughout the manufacture and distribution chain.

The packaging materials used in the FDM sector are textiles, wood, metal, glass, rigid and semi-rigid plastic, flexible plastic films, paper and board. Regulation (EC) No 1935/2004 provides a harmonised legal EU framework. It sets out the general principles of safety and inertness for all food contact materials.

Textiles have poor barrier properties. Textile bags are still used to transport bulk products including grain, flour, sugar and salt. Wooden shipping containers have traditionally been used for a range of foods, such as fruits, vegetables, tea, wines, spirits and beer. Wooden containers were replaced a long time ago in some sectors, and are now increasingly being replaced everywhere by plastic drums and crates.

Hermetically sealed metal cans have high barrier properties and can withstand high and low temperatures. The materials used for metal cans are steel (tinplate or tin-free) and aluminium, but they may also be coated with tin or lacquers to prevent interaction with the foods within the can. Metal cans are widely used for soft drinks and beer. They are also used for canning sterilised foods, e.g. fruit, vegetables, condensed milk and meat products. Metal cans are recyclable. Aluminium foil is also widely used to pack several types of food.

Glass has high barrier properties, is inert, and is suitable for heat and microwave processing. However, two disadvantages of glass are the weight and the risk of fracturing. Glass bottles and jars are widely used for milk, beer, wines and spirits, preserves, pastes and purées and also for some foods and instant drinks. Glass bottles and jars are reusable and recyclable.

Rigid and semi-rigid plastic containers include bottles, jars, cups, trays and tubs made from single or co-extruded polymers. They are low weight, tough and unbreakable, easy to seal, have reasonably high barrier properties and great chemical resistance. Several techniques are available for the production of these containers, such as thermoforming, blow moulding, injection blow moulding, extrusion blow moulding and stretch blow moulding. Typical materials used are PVC (polyvinylchloride), PS (polystyrene), PP (polypropylene), expanded polypropylene (for thermoforming), HDPE (high-density polyethylene), PET (polyethylene terephthalate), and polycarbonate. The containers are often made on site. Some of the containers are reusable, e.g. polycarbonate bottles for milk. Rigid and semi-rigid plastic containers are typically used for milk, soft drinks, dairy products, margarine, dried foods and ice cream.

Flexible films are formed from non-fibrous plastic polymers, which are normally less than 0.25 mm thick. Typical materials used for flexible films are PE (polyethylene), low-density polyethylene, PP, PET, HDPE, PS, and PVC. In general, flexible films are relatively cheap; they can be produced with a range of barrier properties; they are heat-sealable; add little weight; can be laminated to paper, aluminium and other plastics; and are easy to handle. Flexible films are used for packaging a large range of both wet and dry food products.

Finally, paper and board can be produced in many grades and many different forms. They are recyclable and biodegradable and can easily be combined with other materials. Laminated cardboard packs are used on a large scale for milk and fruit juices. Paper and board are also used extensively for food packaging and often as secondary packaging.

An important step in the packing process is the sealing of the container or packs. The maintenance of the food quality depends largely on adequate sealing of the packs. Seals are usually the weakest part of the packs and also suffer the most frequent faults during production, e.g. when food is trapped in a seal, or due to incorrect sealing temperatures or incorrect can seamer settings. Cans are seamed and glass bottles and jars are sealed with metallic caps, plastic caps or corks. Form-fill-sealing is now a well-established technique. In this process, the container is formed and partly sealed, filled and then finally closed by full sealing.

The requirements for filling are accuracy, to ensure that the required amount of product is packed, and hygiene, to ensure that the product is hygienically filled at the correct temperature to guarantee the highest possible quality and optimum shelf life. The selection of an appropriate filling technique depends on the nature of the product and the production rate required. The filling can be by level, volume or weight.

Level filling is most frequently used in the drink industry, especially for beer. Volumetric filling is applied to liquids, pastes and powders. The most common is the piston filler. Finally, weight filling is applied to large particulate materials, e.g. confectionery. These are filled into containers using a photoelectric device, to count individual pieces. Also multi-head weighers are being developed which aim to weigh different products simultaneously, prior to filling into the same container.

Containers need to be filled accurately without spillage and without contamination of the seal. The filling of liquid foods like milk and fruit/vegetable juices can be categorised by the temperature of the food at the time of filling, e.g. hot, ambient or fresh cold filling, or as aseptic filling. The temperature ranges involved in the filling process are best illustrated by the hot filling and fresh cold filling processes. Hot filling is undertaken at temperatures of up to 95 °C, to inactivate certain relevant microorganisms, whilst many drink products are formulated with ingredients that do not need to be heat-treated to be microbiologically safe and these are, therefore, fresh cold filled at between 0 °C and 5 °C. For aseptic packing, pre-sterilised, e.g. by hydrogen peroxide, containers are necessary, and the filling needs to take place in a sterile zone.

Solid waste includes cast-offs due, for example, to packaging machine faults/inefficiencies during filling, and capping process waste, especially during machine start-ups and shutdowns. Processes such as glass bottle blowing are usually completed off site by suppliers but waste can result from breakages in situ. Bottle blowing of PET may be carried out on site using either PET pellets or supplied preforms. This produces waste from offcuts. Aluminium or steel can cylinders and aluminium can ends are pre-manufactured off site. Laminated cartons and pouches are formed on site. This results in waste from offcuts. Small amounts of solid waste are produced from inks and from the cleaning of printing equipment. The lubrication of equipment and the transport systems also produce waste. Some packaging is recycled.

2.1.5 Waste water treatment

2.1.5.1 Introduction

Water pollution control can be carried out by reducing the volume and pollutant load of the waste water generated, by an appropriate combination of:

- process-integrated techniques such as eliminating or decreasing the concentration of certain pollutants, reducing water consumption, recycling/reducing raw materials and by-products, recycling or reusing water;
- end-of-pipe techniques, i.e. waste water treatment; the techniques for waste water treatment are listed in Section 2.1.5.3.

Waste water treatment is an end-of-pipe treatment which is required because waste water is produced from various sources. Although the FDM sector is an extremely diverse sector, certain sources of waste water are common to many of its sectors. These sources may include:

- washing of the raw material;
- steeping of raw material;
- water used for transporting or fluming raw material or waste;
- cleaning of installations, process lines, equipment and process areas;
- cleaning of product containers, washing of packaging materials;
- blowdown from steam boilers;
- once-through cooling water or bleed from closed-circuit cooling water systems;
- backwash from regeneration of the WWTP;
- freezer defrost water;
- storm water run-off.

Waste water treatment is applied after process-integrated operations have minimised both the consumption and the contamination of water. Techniques widely applicable in the FDM sector achieve environmental benefits such as waste minimisation and may achieve some or all of the following effects related to a specific waste water stream:

- reduction in the volume;
- reduction in the pollutant load;
- elimination of, or decrease in, the concentration of certain substances;
- increase in the suitability for recycling or reuse.

These techniques are discussed throughout this document. Some are applicable in the whole FDM sector and others are only applicable in individual unit operations or sectors.

There are many factors which influence the choice of waste water treatment. The main factors are:

- volume and composition of the waste water being discharged;
- the local situation in terms of the receiver of the discharge, e.g. MWWTP, river, estuary, lake, sea, and any discharge limits applied;
- economics;
- the removal of pollutants, including for example dangerous substances as defined in Council Directive 76/464/EEC [114, EEC 1976] and priority hazardous substances as defined in Directive 2000/60/EC [164, WFD 2000/60/EC 2000].

2.1.5.2 Waste water discharge

The three main options for discharging waste water from a FDM installation are:

- direct discharge to a receiving water body;
- indirect discharge to a WWTP;
- landspreading of waste water.

Of the 353 questionnaires received during the FDM data collection (see Annex I, Section 19.1), 134 concern WWTPs that discharge directly to a receiving water body, 148 concern indirect discharges, while 13 concern landspreading. Most of the direct discharges were to a river and most of the indirect discharges were to municipal WWTPs (Figure 2.2). In the case of direct discharge to a receiving water body, the waste water needs to be treated. Waste water needs to be partly treated before indirect discharge to a WWTP in many cases (e.g. equalisation, neutralisation, fat trap).

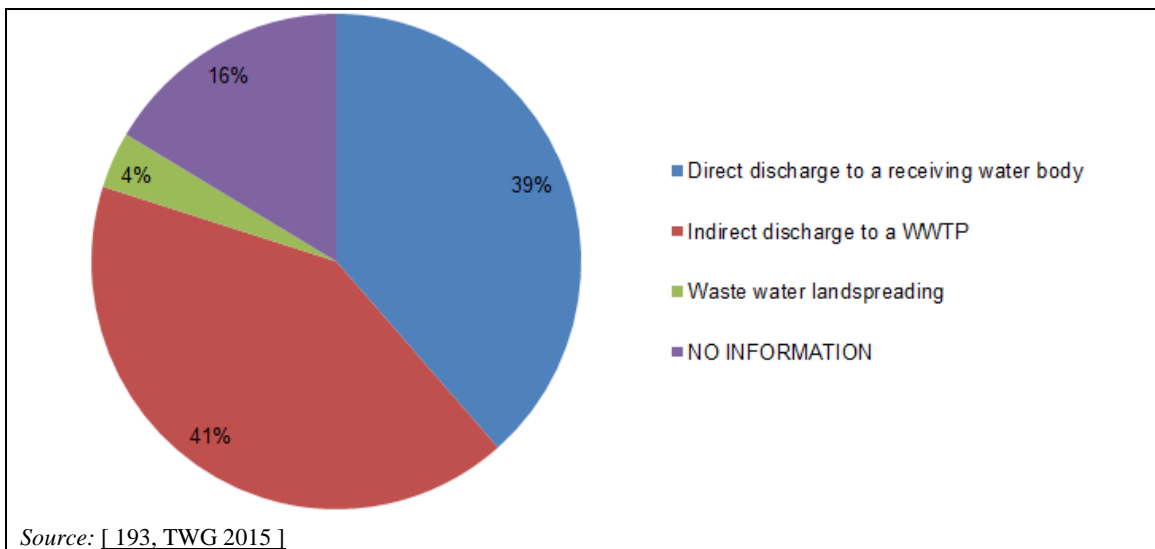

Figure 2.2: Distribution of FDM installations participating in the data collection according to the type of discharge

Where it is essential for the installation to be close to the source of its raw material, i.e. in a remote location, there may be no alternative but to carry out full treatment and discharge to a local watercourse. In most cases, however, two or more options will merit detailed consideration. Waste water disposal may be a major factor in the choice of site for new installations.

The advantages of the treatment of individual waste water streams on site are reported to be [8, Environment Agency of England and Wales 2000]:

- more flexibility for increased production, or for reacting to changing conditions;
- facilities for treatment at source are usually tailor-made and so normally perform well;
- operators of the production units demonstrate a more responsible attitude towards waste water treatment when they are made responsible for the quality of their own waste water discharge.

The advantages of treatment at an on- or off-site combined/mixed waste water installation are reported as follows:

- making use of mixing effects, such as temperature or pH;
- lower capital costs due to economy of scale;
- more effective use of chemicals and equipment, thus decreasing relative operating costs;
- dilution of certain contaminants which may be difficult to treat individually, e.g. emulsified fats and sulphates.

Where waste water is treated in an off-site WWTP, the above advantages apply, provided that:

- the treatment at the off-site WWTP is as good as would be achieved if treated on site, particularly in terms of the load, but not the concentration, of each substance discharged to the receiving water;
- there is an acceptably low probability of the treatment plant being bypassed, via surface/emergency overflows or at intermediate pumping stations;
- there is a suitable monitoring programme in place for emissions to an off-site WWTP, taking into consideration the potential inhibition of any downstream biological processes.

Additionally, the off-site WWTP may benefit by receiving the FDM waste water, e.g. because of its biodegradability.

2.1.5.2.1 Waste water landspreading

Effluents of FDM industries contain water and fertilising nutrients coming mainly from the raw materials. Their return to agriculture is an option, considering the large amounts of fertilisers replaced when landspreading is carried out according to the crops' needs.

There is a proposal for a Regulation of the European Parliament and of the Council on minimum quality requirements for reused water in the EU⁴, accompanied by an Impact Assessment on the minimum requirements for water reuse.

Waste water landspreading should be carried out in line with legal requirements [104, EEC 1991] and according to the agricultural needs. Only waste water beneficial to the soil or crop nutrition can be spread, and landspreading is subject to strict regulation, local threshold values and monitoring measures. Waste water is spread only when there is an available crop that can benefit from the nutrients applied to the field. Waste water landspreading is strictly prohibited in the following situations:

- during periods when the soil is largely frozen or covered in abundant snow;
- during heavy rain periods and periods with a risk of flooding;
- outside regularly cultivated land and operated pastures or forests;
- on steep-sloped terrains, under conditions that would lead to run-off outside the scope of the landspreading process;
- using air sprays generating fine mist when the waste water is likely to contain pathogenic microorganisms.

⁴ COM(2018) 337 final - 2018/0169 (COD) and annexes 1 to 2.

2.1.5.3 Waste water treatment techniques

2.1.5.3.1 Introduction

The descriptions of the various waste water treatment techniques in the following sections show the sequence that the techniques typically follow to progressively achieve a better quality of waste water. Due to the nature of the raw materials used and the products produced, waste water arising from the FDM sector is primarily biodegradable in nature. However, cleaning and disinfection agents may represent a problem if they are poorly degradable.

Table 2.4 shows the waste water treatment techniques described in Section 2.3.6, and in which FDM sectors and how many FDM installations they are applied, according to the FDM data collection.

Table 2.4: Waste water treatment techniques reported in the FDM data collection

Technique	BREF Section	FDM sectors (number of FDM installations)
Preliminary, primary and general treatment		
Equalisation	Section 2.3.6.1.1	AN (1), BR (14), DA (26), ET (1), FR (9), ME (1), OI (8), ST (8), SU (6)
Neutralisation	Section 2.3.6.1.2	BR (14), DA (28), FR (3), ME (3), OI (5), SO (5), ST (3), SU (2)
Screening	Section 2.3.6.1.3	AN (1), BR (15), DA (14), FR (15), ME (9), OI (2), SO (2), ST (2), SU (6)
Fat trap or oil separator for the removal of FOG and light hydrocarbons	Section 2.3.6.1.4	AN (2), DA (14), FR (2), ME (11), OI (9), OL (1), SU (1)
Buffer storage for waste water incurred during other than normal operating conditions	Section 2.3.6.1.5	BR (10), DA (11), FR (3), ME (1), OI (1), ST (4), SU (1)
Secondary treatment – Aerobic treatment		
Activated sludge	Section 2.3.6.2.1.1	BR (12), DA (27), ET (1), FR (9), ME (4), OI (13), SO (4), ST (10), SU (13)
Aerobic lagoons	Section 2.3.6.2.1.2	AN (1), BR (1), DA (4), FR (3), ME (2), OI (2), ST (2), SU (11)
Pure oxygen systems	Section 2.3.6.2.1.3	BR (1), DA (1), FR (1), ME (2), ST (1)
Sequencing batch reactors (SBR)	Section 2.3.6.2.1.4	BR (2), DA (2), FR (1), ME (1), OI (1)
Trickling filters	Section 2.3.6.2.1.5	OI (1)
Bio-towers	Section 2.3.6.2.1.6	BR (3), DA (5), ST (1)
Rotating biological contactors	Section 2.3.6.2.1.7	DA (1)
High and ultra-high rate filters	Section 2.3.6.2.1.8	ST (2)
Secondary treatment – Anaerobic treatment		
Upflow anaerobic sludge blanket (UASB)	Section 2.3.6.2.2.1	BR (5), DA (1), FR (5), ST (2), SU (2)
Anaerobic contact processes	Section 2.3.6.2.2.2	BR (2), DA (2), FR (1), SO (1), ST (1), SU (7)
Anaerobic lagoons	Section 2.3.6.2.2.3	SU (5)
Anaerobic filters	Section 2.3.6.2.2.4	DA (2)
Internal circulation reactors	Section 2.3.6.2.2.5	BR (6), DA (2), OI (2), ST (1)
Fluidised and expanded bed reactors	Section 2.3.6.2.2.6	OI (1)
Expanded granular sludge bed reactors	Section 2.3.6.2.2.7	BR (3), ET (1), SU (1)

Technique	BREF Section	FDM sectors (number of FDM installations)
Secondary treatment – Aerobic/anaerobic treatment		
Membrane bioreactors	Section 2.3.6.2.3.1	DA (5), FR (1), OI (1)
Multistage systems	Section 2.3.6.2.3.2	DA (1), SO (1), ST (1), SU (1)
Nitrogen removal		
Biological nitrification and denitrification	Section 2.3.6.3.1	BR (4), DA (22), FR (7), ME (2), OI (1), ST (5), SU (11)
Partial nitrification-anaerobic ammonium oxidation	Section 2.3.6.3.2	DA (1)
Ammonia stripping	Section 2.3.6.3.3	DA (1)
Phosphorus recovery and/or removal		
Phosphorus recovery as struvite	Section 2.3.6.4.1	FR (2)
Precipitation	Section 2.3.6.5	BR (2), DA (9), FR (1), OI (1), SO (1), ST (2), SU (1)
Enhanced biological phosphorus removal (EBPR)	Section 2.3.6.4.3	BR (3), DA (13), FR (2), ME (2)
Final solids removal		
Coagulation and flocculation	Section 2.3.6.5.1	BR (2), DA (8), FR (2), OI (6)
Sedimentation	Section 2.3.6.5.2	AN (2), BR (7), DA (16), FR (12), ME (2), OI (7), SO (3), ST (9), SU (12)
Filtration	Section 2.3.6.5.3	AN (1), BR (2), DA (9), FR (5), ME (3), OI (1), SO (1)
Flotation	Section 2.3.6.5.4	BR (3), DA (21), FR (2), ME (7), OI (13), ST (1)
Membrane filtration	Section 2.3.6.5.5	BR (1), DA (2), FR (2), OI (1)
UV radiation	Section 2.3.6.5.6	BR (1), DA (1)
Natural treatment		
Integrated constructed wetlands	Section 2.3.6.6.1	DA (1)
Sludge treatment		
Sludge conditioning	Section 2.3.6.7.1.1	AN (1), BR (2), DA (2), FR (2), ME (2), SO (1)
Sludge stabilisation	Section 2.3.6.7.1.2	BR (1), DA (8), FR (2), OI (1), ST (3)
Sludge thickening	Section 2.3.6.7.1.3	BR (4), DA (10), ET (1), FR (6), ME (1), OI (1), SO (2), ST (4), SU (4)
Sludge dewatering	Section 2.3.6.7.1.4	BR (6), DA (18), FR (8), ME (2), OI (7), ST (4), SU (2)
Sludge drying	Section 2.3.6.7.1.5	BR (2), DA (1), FR (2), ST (1)
NB: Figures in brackets indicate the number of installations per FDM sector that have implemented the technique. AN = animal feed; BR = brewing; DA = dairies; ET = ethanol production; FI = fish and shellfish processing; FR = fruit and vegetables; GR = grain milling; ME = meat processing; OI = oilseed processing and vegetable oil refining; OL = olive oil processing and refining; SO = soft drinks and nectar/juice made from fruit and vegetables; ST = starch production; SU = sugar manufacturing. Source: [193, TWG 2015]		

Waste water in the FDM sector may have the following typical characteristics:

- solids (gross and finely dispersed/suspended);
- low and high pH level;
- free edible fat/oil;
- emulsified material, e.g. edible fat/oil;
- soluble biodegradable organic material, e.g. BOD;
- volatile substances, e.g. ammonia and organics;
- plant nutrients, e.g. phosphorus and/or nitrogen;
- pathogens, e.g. from sanitary water;
- dissolved non-biodegradable organics.

Waste water produced in the various sectors may vary considerably in composition and pollution levels, and a variety of techniques may be used to treat it. Combinations of techniques are frequently used to treat heavily polluted waste water.

2.1.5.3.2 Primary treatment

Primary treatment is designed to remove gross, suspended and floating solids from raw sewage. It includes screening to trap solid objects and sedimentation by gravity to remove suspended solids. This level is sometimes referred to as mechanical treatment, although chemicals are often used to accelerate the sedimentation process. Primary treatment can reduce the BOD of the incoming waste water by 20–30 % and the total suspended solids by some 50–60 %. Primary treatment is usually the first stage of waste water treatment [232, World Bank Group 2016].

Typical techniques for primary treatment are screening, fat trap for the removal of FOG and light hydrocarbons, flow and load equalisation, neutralisation, sedimentation, dissolved air flotation, centrifugation or precipitation.

2.1.5.3.3 Secondary treatment

Secondary treatment is directed principally towards the removal of biodegradable organics and suspended solids using biological methods. Adsorption of pollutants to the organic sludge produced will also remove non-biodegradable materials, e.g. heavy metals. Organic nitrogen and phosphorus can also be partially removed from the waste water. Secondary treatment options can be used alone or in combination, depending on the characteristics of the waste water and the requirements before discharge.

There are essentially three types of metabolic processes, i.e. aerobic processes, using dissolved oxygen; anaerobic processes, without oxygen supply; and anoxic processes, using biological reduction of oxygen donors [8, Environment Agency of England and Wales 2000], [35, Germany 2002], [58, FoodDrinkEurope 2002]. This section describes techniques that use mainly aerobic and anaerobic metabolic processes.

Aerobic processes

Aerobic processes are only generally applicable and cost-effective when the waste water is readily biodegradable. Microorganisms in the mixed liquor can receive the oxygen input from either the surface or from diffusers submerged in the waste water. Surface injection of oxygen is carried out by means of either surface aerators or oxygenation cages. The advantages and disadvantages of aerobic waste water treatment processes are shown in Table 2.5.

Table 2.5: Advantages and disadvantages of aerobic waste water treatment processes

Advantages	Disadvantages
Degradation into harmless compounds	Large quantities of sludge produced
	Stripping results in fugitive releases that may cause odours/aerosols
	Bacterial activity is reduced at low temperatures. Nevertheless, surface aeration and the injection of pure oxygen can be used to enhance the process
	If FOG is not removed prior to aerobic biological treatment, it may hinder the operation of the WWTP as it is not easily degraded by bacteria
<i>Source:</i> [1, CIAA 2002], [8, Environment Agency of England and Wales 2000], [35, Germany 2002]	

Anaerobic processes

In the absence of oxygen, organic matter is broken down, producing methane (CH₄) as a by-product, which can be used to heat the reactors. In standard anaerobic processes, the reactors are usually unheated, but in high-rate anaerobic processes, the reactors are usually heated. In both cases, the temperature of the reactor has to be maintained at around 30–35 °C (mesophilic) or 45–50 °C (thermophilic), and whether heat is required depends essentially on the temperature of the feed [78, Metcalf & Eddy 1991], [110, CIAA 2003]. The main advantages and disadvantages of anaerobic waste water treatment processes, compared to aerobic processes, are shown in Table 2.6.

Table 2.6: Advantages and disadvantages of anaerobic waste water treatment processes

Advantages of anaerobic treatment	Disadvantages of anaerobic treatment
Low specific surplus sludge production; the lower growth rates mean lower macro/micro nutrient requirements	Mesophilic bacteria, which thrive at 20–45 °C, may require an external source of heat
Low energy requirements due to lack of forced ventilation	Low growth rate requires good biomass retention
Generally lower capital and operating costs per kg of COD removed. These are associated with a decrease in sludge production and lower mixing costs	Initial commissioning/acclimatisation phase can be long (not for reactors with granular sludge, e.g. EGSB, seeded with the sludge of operating plants)
Produces biogas that can be used for power or heat generation	Anaerobic systems are more sensitive than aerobic systems to fluctuations in temperature, pH, concentration and pollution loads
Small space requirements	Some constituents of treated waste water can be toxic/corrosive, e.g. H ₂ S
Can be easily decommissioned for extended periods and remain in a dormant state (useful for seasonal manufacturing processes, e.g. sugar beet)	
A particular advantage of the process is the formation of pellets. This permits not only rapid reactivation after months-long breaks in operation, but also the sale of surplus sludge pellets, e.g. for the inoculation of new systems	
Some substances that cannot be degraded by aerobic means can be degraded anaerobically, e.g. pectin and betaine	
Less odour problems, if appropriate abatement techniques are employed	
No aerosol formation, can assimilate FOG (not for UASB)	
<i>Source:</i> [8, Environment Agency of England and Wales 2000], [35, Germany 2002], [58, FoodDrinkEurope 2002]	

Although anaerobic growth is slower than in an aerobic process, higher BOD loadings are achievable with an anaerobic technique (in terms of kg BOD/m³ of reactor volume) for highly polluted waste water. Anaerobic techniques are generally utilised in those industries where there is a high level of soluble and readily biodegradable organic material and the concentration of the waste water, expressed in COD, is generally greater than 1 500–2 000 mg/l. For the FDM sector, the application of anaerobic waste water treatment is largely confined to relatively heavily polluted waste water with a COD between 3 000 mg/l and 40 000 mg/l, e.g. in the sugar, starch, fruit and vegetable and alcoholic drinks sectors. There has been some success in using certain anaerobic systems even for less heavily polluted waste water with a COD between 1 500 mg/l and 3 000 mg/l, e.g. in breweries, dairies and in the fruit juice, mineral water and soft drinks sectors [35, Germany 2002]. Where there are large fluctuations in volume and pollutant load, e.g. for waste water in the fruit and vegetable sector, this treatment is less effective.

One of the most fundamental aspects of anaerobic waste water treatment is that the vast majority of organic carbon associated with the influent BOD is converted to methane as opposed to being used for new cell growth. The opposite is true with aerobic processes, which convert most of the organic carbon to new cells which eventually form waste biosolids that require either further treatment or off-site disposal. Anaerobic processes produce much less waste sludge. Also, the methane produced has a high calorific value and as such can be reused as fuel, e.g. elsewhere in an installation.

An anaerobic system alone would not achieve a final waste water quality high enough for discharge to a watercourse. Therefore anaerobic installations are usually followed by an aerobic system (see Section 2.3.6.2.1), as the latter achieves lower absolute emissions levels, and will remove hydrogen sulphide, ensuring that the final waste water is well aerated to assist in the breakdown of the remaining BOD. The energy gained from the anaerobic plant can be equivalent to that consumed by the aerobic plant. In certain circumstances, the aerobic treatment may be the municipal WWTP. This will depend upon the receiving WWTP and the balance between waste water treatment charges and an on-site aerobic treatment stage. The anaerobically treated waste water may be surface-aerated on site prior to transfer to a municipal WWTP. This is normally carried out in a post-treatment holding tank providing positive dissolved oxygen levels before being discharged to a WWTP.

The methanogenic bacteria involved in the final stage of the anaerobic process, producing the methane gas, need to be protected from excessive chlorinated and sulphur compounds, pH and temperature fluctuations. In the acidification stage other bacteria will predominate and break down many of the substances which cause the problems. Due to the slow microbial growth there is no phosphorus removal. No nitrification and denitrification occurs so nitrogen cannot be removed by anaerobic treatment.

Modern reactor designs permit higher loading rates, increase biogas production or offer greater stability. Once the bacterial populations in such systems are adapted to the waste water then increased stability occurs.

On-site treatment facilities relying upon an anaerobic reactor as the main treatment process have a similar layout. They have a waste water collection sump/vessel or equalisation tank from which the waste is pumped/flows to a primary treatment tank. The primary treatment processes are as described for aerobic systems.

From the primary treatment stage, the waste water is passed to a conditioning or buffer tank where the waste water is conditioned, e.g. pH correction or nutrient addition, before it is passed via the influent distribution system through to the bioreactor. Early anaerobic reactors allow the initial stages of the anaerobic metabolism to be initiated in the conditioning tank (often referred to as the acidification tank). Modern reactor designs allow all the metabolic pathways to take place in the reactor. The conditioning tank is, therefore, generally only required for pH correction and nutrient addition.

Treatment occurs in the reactor, producing biogas which is collected. Other components often included are a sludge storage tank, vent gas disposal and primary treatment facilities.

Some common operational problems experienced with anaerobic treatment processes are given in Table 2.7.

Table 2.7: Common operational problems experienced with biological treatment processes

Problem	Possible solution
Lack of macro-nutrients	BOD:N:P ratios are normally maintained at 500:5:1
pH	The pH is maintained at 6.8–7.5
Temperature	The optimum temperature for mesophilic bacteria is 35–37 °C
Lack of micro-nutrients	Minimum quantities of micro-nutrients are maintained, especially for Fe, Ca, Mg and Zn, according to the specific process employed
Physical blockage of the reactor inlet pipework	Effective screening and primary treatment is essential
Overloading	Care needs to be taken to ensure the original hydraulic, solid and organic loading design rates do not exceed the manufacturer's recommendations
<i>Source: [8, Environment Agency of England and Wales 2000]</i>	

2.1.5.3.4 Tertiary treatment

After secondary treatment, further treatment may be needed either to enable the water to be reused as process water or low-grade wash water, or to meet discharge requirements. Tertiary treatment refers to any process that is considered a polishing step, up to and including disinfection and sterilisation systems.

In this document, tertiary treatment means an advanced treatment of the waste water to remove constituents of particular concern including ammonia, plant nutrients, dangerous and priority hazardous substances or residual TSS and organics.

Plant nutrients, i.e. nitrogen and phosphorus, need to be removed before discharge into surface water in sensitive areas [165, EEC 1991]. In selecting an appropriate nutrient control strategy, it is important to assess:

- the characteristics of untreated waste water;
- the type of WWTP to be used;
- the level of nutrient control required;
- the need for seasonal or year-round nutrient removal.

2.1.5.3.5 Natural treatment

In the natural environment, biological and physico-chemical processes occur when water, soil, plants, microorganisms and the atmosphere interact. Natural treatment systems are designed to take advantage of these processes, to provide waste water treatment. The processes involved include many of those used in conventional waste water treatment systems, such as sedimentation, filtration, precipitation and chemical oxidation, but occur at natural rates [78, Metcalf & Eddy 1991]. They are slower than conventional systems.

The soil-based systems mainly use the complex purification mechanism of the soil and uptake by crops and other vegetation. In the aquatic-based systems, e.g. natural and constructed wetlands and aquatic plant systems, the vegetation provides a surface for bacterial growth. Natural treatments are prohibited by law in some MS, due to concerns about hazards to groundwater [94, Germany 2003].

2.1.5.3.6 Sludge treatment

This section covers the treatment of waste water sludge. Techniques for the use and disposal of waste water sludges off site are not covered in this document. The choice of sludge treatment may be influenced by the use and disposal options available to the operator. These include landspreading, disposal by landfill, use as a sealing material, incineration, co-incineration, wet oxidation, pyrolysis, gasification, vitrification.

The capital and operating costs associated with sludge treatment can be high compared with the rest of the WWTP activities and consequently merit consideration, to minimise costs, at an early stage in designing an installation.

Sludge treatment techniques on site generally either reduce the volume for disposal or change its nature for disposal or reuse. Typically, volume reduction through dewatering can occur on site, whereas further sludge treatment is generally carried out off site. Reducing the volume of sludge for disposal leads to reduced transport costs and, if going to landfill, reduced landfill charges [8, Environment Agency of England and Wales 2000]. The on-site treatment techniques normally applied in the FDM sector are detailed in Section 2.3.6.7.

2.1.6 Treatment of emissions to air

Emissions to air can be divided into ducted, diffuse, and fugitive emissions. Fugitive emissions are a subset of diffuse emissions. Only ducted emissions can be treated. Diffuse and fugitive emissions can, however, also be prevented and/or minimised. The CWW BREF gives an indication of the techniques for the prevention and reduction of TVOC emissions [168, COM 2016]. The sources of ducted emissions in the FDM sector are:

- process emissions, released through a vent pipe by the process equipment and inherent to the running of the installation, e.g. in frying, boiling, cooking operations;
- waste gases from purge vents or preheating equipment, which are used only in start-up or shutdown operations;
- emissions from vents from storage and handling operations, e.g. transfers, the loading and unloading of products, raw materials and intermediates;
- hot gases from units providing energy, such as process furnaces, steam boilers, combined heat and power units, gas turbines, gas engines;
- waste gases from emission control equipment, such as filters, thermal oxidisers or adsorbers;
- waste gases from solvent regeneration, e.g. in vegetable oil extraction installations;
- discharges of safety relief devices, e.g. safety vents and safety valves;
- exhaust of general ventilation systems;
- exhaust of vents from captured diffuse and/or fugitive sources, e.g. diffuse sources installed within an enclosure or building.

The main sources of diffuse and fugitive emissions in the FDM sector are:

- process emissions from the process equipment and inherent to the running of the installation, released from a large surface or through openings;
- working losses and breathing losses from storage equipment and during handling operations, e.g. filling of drums, trucks or containers;
- emissions from flares;
- secondary emissions, resulting from the handling or disposal of waste, e.g. volatile material from sewers, waste water handling facilities or cooling water;
- odour losses during storage, filling and emptying of bulk tanks and silos;
- stripping of odorous compounds from a WWTP resulting in releases to air and/or odour problems;

- storage tank vents;
- fumigation;
- pipework leaks;
- vapour losses during storage, filling and emptying of bulk solvent tanks and drums, including hose decoupling;
- burst discs and relief valve discharges;
- leakages from flanges, pumps, seals and valve glands;
- building losses from windows, doors, etc.;
- settling ponds;
- cooling towers and cooling ponds.

The main air pollutants from FDM processes, not including the pollutants released in associated activities such as energy production, are:

- dust;
- VOC and odour (some caused by VOC);
- refrigerants containing ammonia and halogen;
- products of combustion, such as CO₂, NOX and SO₂.

2.1.6.1 Process-integrated techniques

Process-integrated procedures to minimise emissions to air generally have other environmental benefits, such as optimising the use of raw materials and minimising waste generation. Some of the techniques described as air abatement techniques are also integrated in the process and enable the recovery of materials for reprocessing, e.g. cyclones (see Section 2.3.4.6).

2.1.6.2 Treatment techniques for emissions to air

Measures are designed to reduce not only the mass concentrations, but also the mass flows of the air pollutants originating from a unit operation or a process.

Table 2.8 lists some widely used air treatment techniques and the number of FDM installations in which they are applied, according to the FDM data collection.

Table 2.8: End-of-pipe treatment techniques for emissions to air reported in the FDM data collection

Technique	BREF Section	FDM sectors (number of FDM installations)
Separator	2.3.7.2.1	AN (1), OI (2)
Bag filter	2.3.7.2.2	AN (44), BR (55), DA (57), GR (63), ME (1), OI (70), ST (31), SU (13)
Cyclone	2.3.7.2.3	AN (34), BR (42), DA (38), ET (1), GR (4), ME (3), OI (73), ST (40), SU (23)
Wet scrubber	2.3.7.3.1	AN (1), DA (9), ET (1), ME (1), OI (13), ST (8), SU (12)
Electrostatic precipitator	2.3.7.2.4	OI (1)
Carbon adsorption	2.3.7.3.3	ME (1)
Bioscrubber	2.3.7.3.5	AN (1), OI (2)
Biofilter	2.3.7.3.4	AN (1), DA (1), ME (1), OI (5)
Thermal oxidation	2.3.7.3.6	ME (1), OI (1), ST (2), SU (1)
Catalytic oxidation	2.3.7.3.7	DA (1), OI (1)
NB: Figures in brackets indicate the number of installations per FDM sector that have implemented the technique.		
Source: [193, TWG 2015]		

The characteristics of the emission determine the selection of the most appropriate technique. This may need some flexibility, to enable the treatment of additional sources identified at a later date. Table 2.9 shows the key parameters for the selection procedure.

Table 2.9: Key parameters for the end-of-pipe selection procedure

Parameter	Unit
Flow rate	m ³ /h
Temperature	°C
Relative humidity	%
Typical range of components present	–
Dust level	mg/Nm ³
Organic level	mg/Nm ³
Odour level	OU _E /Nm ³
<i>Source: [192, COM 2006]</i>	

In some cases, the components of the emission are easily identified. In the case of odour, the emission to be treated usually contains a complex cocktail and not just one or two readily definable components. The abatement plant is, therefore, often designed based on experience within other similar installations. The uncertainty caused by the presence of a considerable number of airborne components may necessitate the need for pilot plant trials. The flow rate to be treated is a major parameter in the selection process and very often the abatement techniques are listed against the optimum flow rate range for their application.

Transport of ducted emissions to the treatment plant needs careful consideration, to minimise any operational problems. In particular, the potential for particulate deposition and the potential for condensation of water and other airborne contaminants can result in severe fouling, requiring frequent cleaning, and may lead to hygiene problems. Incorporating cleaning points and drain valves in the ventilation ductwork enables cleaning to remove accumulated material.

The purchase of an abatement plant will normally include a number of guarantee statements, e.g. relating to mechanical and electrical reliability for a period of at least one year. As part of the selection and procurement procedure, the supplier will also require information regarding the removal efficiency of the process. The form of the process guarantee is an important part of the contract. For example, guarantee statements relating to odour removal performance can take a number of forms. In the absence of any olfactometric data then the guarantee might simply state no perceivable odour outside the process boundary or outside the installation site.

Extremely high standards for clean gas dust concentrations can be achieved by using two-stage layouts of high-performance separation techniques, e.g. using two fabric filters or using them in combination with HEPA filters (described in the CWW BREF [168, COM 2016]) or with ESP filters.

Table 2.10 shows a comparison of the performance of some separation techniques.

Table 2.10: Comparisons of some separation techniques

Technique	Dust particle size (μm)	Collection efficiency at 1 μm (%)	Maximum operating temperature ($^{\circ}\text{C}$)	Comments
Cyclone	10	40*	1 100	Coarse particles. Used to assist other methods
Wet separation	1–3	> 80–99	Inlet 1 000 Outlet 80	Good performance with suitable dust types. Acid gas reduction
Dry ESP	< 0.1	> 99 depending on design	450	Four or five zones. Usual application is pre-abatement
Wet ESP	0.01	< 99	80	ESP with two zones in series. Mainly mist precipitation
Filtration, i.e. fabric filter	0.01	> 99.5	220	Good performance with suitable dust type
Filtration, i.e. ceramic filter	0.01	99.5	900	Very good performance with suitable dust types
NB: * For larger particle sizes and high-performance cyclones, collection efficiencies of around 99 % can be achieved. Source: [35, Germany 2002], [109, Finland 2003]				

More information about techniques for reducing emissions to air is given in the following chapters.

2.1.6.2.1 Dynamic separation techniques

The basis for the separation and removal of particles in dynamic separators are the field forces, which are proportional to the mass of the particles. Hence, gravity separators, deflection or inertia separators and centrifugal separators, such as cyclones, multicyclones and rotary flow dedusters, are all dynamic separators. They are mainly used for separation of large particles (> 10 μm) only or as an initial step before the removal of fine dust by other means. Use of physical dispersion, via chimney stacks and increasing the dispersion potential by extending the height of the discharge stack or increasing the discharge velocity, is also practised.

2.1.6.2.2 Filters

Filter separators are typically used as final separators, after preliminary separators are used, for example where the waste gas contains components with properties damaging to filters, e.g. abrasive dust or aggressive gases. This ensures adequate filter life and operating reliability.

In filter separators, the gas is fed through a porous medium in which the dispersed solid particles are held back as a result of various mechanisms. Filter separators can be classified on the basis of the filter medium, performance range and filter cleaning facilities, as summarised in Figure 2.3.

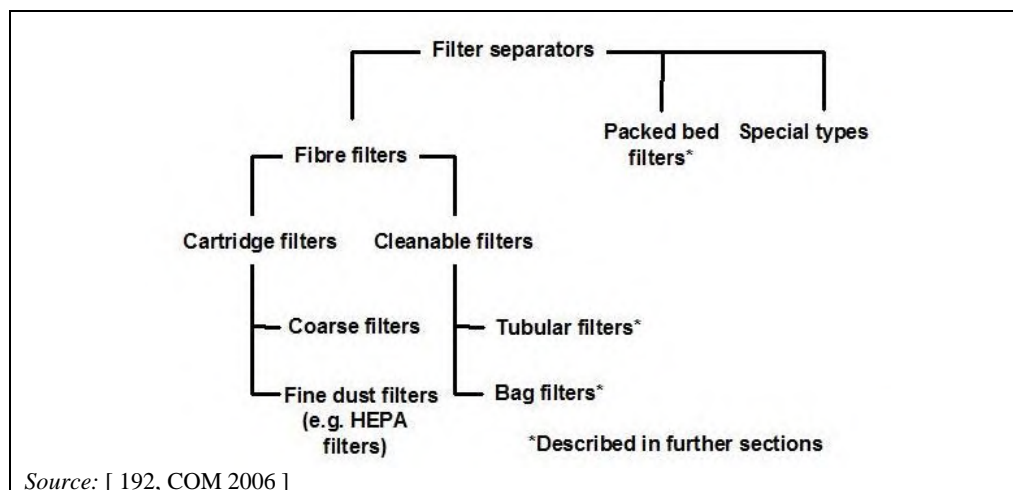

Figure 2.3: Types and classification of filters

In a fabric or fibre filter, waste gas is passed through a tightly woven or felted fabric, causing dust to be collected on the fabric by sieving or other mechanisms. Fabric filters can be in the form of sheets, cartridges or bags (the most common type) with a number of the individual fabric filter units housed together in a group. The dust cake that forms on the filter can significantly increase the collection efficiency.

Cleanable filters are among the most important types of filter separators used in industrial particulate removal. The practice of using a woven fabric filter material has largely changed to the use of non-woven and needle-felt materials. The most important parameters in cleanable filters are the air to cloth ratio and the pressure loss.

The filter material performs the actual separation and is the essential component of a filter separator. Woven fabrics have threads which cross at right angles. Non-wovens and needle-felts, by contrast, are flat three-dimensional structures that may be stabilised by the adhesion of the fibres or by alternating the insertion and removal of fibres. Non-wovens and needle-felts may also contain an internal supporting woven fabric, e.g. polyester or glass fibre fabric, to reinforce them. Needle-felts made of synthetic fibres are being increasingly used.

Non-wovens and needle-felts possess three-dimensional filtering characteristics. Dust particles are caught in the filter structure, forming an ancillary filter layer that ensures good separation of even the finest particles. One characteristic of this deep filtration is a large effective specific surface area. Regular intensive cleaning removes the accumulated dust layer and prevents excessive pressure losses. Problems, however, may be caused by sticky, fatty, agglomerating, adhesive, abrasive and/or hygroscopic dust particles.

2.1.6.2.3 Absorption

The words absorber and scrubber are sometimes used interchangeably and this can cause confusion. Absorbers are generally used for trace gas removal and scrubbers for particulate abatement. This distinction is not always so rigid, as odour and gaseous components in the air may also be removed together with dust by using vapour condensation or wet scrubbing (see wet separators in Section 2.3.7.3.1).

The aim of absorption is to make the largest possible liquid surface available and provide a good countercurrent flow of gas and liquid. The absorption process relies on the preferential solubility of the polluting components present in the exhaust stream within the absorption medium. There are a number of different types of absorber design based on the contact between the gas and the liquid, and many variations with different removal efficiency performances.

Principle of operation

The process involves a mass transfer between a soluble gas and a liquid solvent in a gas-liquid contacting device. The rate at which a substance is removed from an airstream depends upon its degree of saturation at the solvent surface within the absorber, which in turn depends upon its solubility and its rate of removal from the circulating solvent by reaction and bleed-off. This rate mechanism determines the efficiency of removal for a particular size of absorption plant and a particular air flow rate. Thus, the efficiency of removal depends on the reaction time, the degree of saturation at the surface of the liquor and the reactivity of the gas components within the absorbing solvent.

Providing the airborne components to be removed are reasonably soluble in water, then an absorber can be designed to achieve a desired removal efficiency. The problem arises in the need to maintain a low enough concentration within the absorbing liquor at the surface to maintain the driving force for dissolution. This often results in excessive volumes of water being needed to achieve a reasonable efficiency. It is, therefore, generally impractical to remove different components effectively using water alone and other absorbents are typically employed.

Water-only systems can, however, be considered as a first stage before other absorbers, but much of their effectiveness is due to mechanisms other than absorption. For example, water absorption of a non-saturated airstream will result in a cooling of the airstream to saturation via the process of adiabatic cooling. This cooling effect can lead to condensation and the removal of components from the airstream as they cool to a temperature below their boiling point.

Design considerations

Effective liquid and air distribution are fundamental requirements in all absorber designs. Optimal design according to standard chemical engineering principles requires data on concentration, solubility and mass transfer for the components to be removed from the gas stream. Most emissions to air from the FDM sector are complex mixtures for which it is difficult to ascertain all the chemical species present and even more difficult to determine their concentrations. The nature and kinetics of the oxidation reactions are generally not known and these are very difficult to determine even for individual compounds. It is claimed that the design of absorption equipment should be empirical rather than scientific. Thus, the volume of packing is chosen according to the volume previously found to give reasonably complete absorption of those compounds that can be absorbed. If there is only limited operational experience with the discharge in question, then pilot plant trials can be undertaken.

Pilot plant trials or previous experience can, therefore, be used to determine the height of the packing required to achieve a given performance. The packing is chosen to allow the required height for the required efficiency. The packing size and type, the linear gas velocity, which determines the absorber diameter, the linear liquid velocity, the gas pressure drop and the absorber efficiency per unit height, which determines the packed height, are all interrelated. The design procedure, therefore, looks towards optimising the design in terms of capital and operating costs, taking into consideration the required volumetric throughput, absorption efficiency and constraints such as possible clogging of the packing and the maximum allowable pressure drop. Typical ranges of the parameters detailed above are shown in Table 2.11.

Table 2.11: Typical absorber design guidelines

Design parameter	Units	Value
Gas velocity	m/s	0.5–2.0
Gas flow rate	kg/m ² /h	2 500–5 000
Liquid flow rate	kg/m ² /h	25 000–50 000
Gas residence time	sec	1–3
Pressure drop	mm/metre	20–50
Liquid bleed rate	% of recycle flow	0–10
Flooding	% of flooding	40–60
<i>Source:</i> [192, COM 2006]		

Absorbing reagents

The efficiency of absorption can be increased if the absorbing liquid contains a reagent which reacts with the components present in the airstream. This effectively reduces the concentration of the airborne components at the liquid surface and thereby maintains the driving force for absorption without the need for vast amounts of absorbing liquid. There are a number of specific reagents that can be employed within absorption systems to remove odorous and other organic components from an airstream. These reagents are generally oxidising solutions.

The most widely applied agents include sodium hypochlorite, hydrogen peroxide, ozone and potassium permanganate. The use of acids and alkalis as absorbing mediums is also fairly widespread and often the acid/alkali system is employed in conjunction with an oxidising absorbent. Due to the considerable number of components that can be present in the emissions to air from a food processing installation, multistage absorbers are often used. Thus, an absorbing system could comprise an initial water scrubber followed by an acid or alkali stage and finally an oxidising stage.

Sodium hypochlorite is a very widely applied oxidising agent, primarily due to its high reactivity. Hypochlorite has been found to be particularly useful in installations with significant emission levels of sulphur- and nitrogen-based odorous compounds.

Hypochlorite is generally used at an alkaline pH to prevent dissociation into free chlorine. There is a tendency for the hypochlorite to react with certain components via a chlorination rather than an oxidation reaction. This is a particular concern where an airstream contains aromatic material which could generate chlorinated aromatic compounds in the treated gas stream. The chlorination potential is greater at higher hypochlorite concentrations, so a design incorporating lower hypochlorite concentrations in the absorbing liquor than is actually required for optimal absorption reduces the risk of this occurring.

To address this, a new process was developed which is essentially a conventional hypochlorite absorber, but with a catalyst incorporated into the liquid recycling system. The catalyst is based on nickel oxide and the system is claimed to dramatically increase the hypochlorite reaction rate and prevent any chlorination reactions. The potential chlorination reaction is avoided as the catalyst promotes the decomposition of the hypochlorite into gaseous oxygen and sodium chloride as opposed to free chlorine. This in turn allows the use of increased hypochlorite concentrations in the absorber and improved efficiency. The pH is controlled to approximately pH 9 and the redox potential is controlled to an optimised voltage.

Hydrogen peroxide is generally less effective than hypochlorite, due to its lower oxidising power. It does, however, have the advantage that its reaction product is water and can be used for applications where aromatics are present, for reasons mentioned above. Hydrogen peroxide is usually used under acidified conditions, primarily to control its rate of decomposition.

Ozone is also a powerful oxidising agent, although its oxidative power is more pronounced in the liquid phase than in the gas phase. An application that incorporates ultraviolet light to enhance the oxidative performance of ozone is discussed further in Section 2.4.1.

A number of surfactant-based absorbing solutions have been used, although there is limited information available on their performance. In particular, a non-ionic-based surfactant system with reduced foaming, such as the material used for dishwasher rinse aids, has been employed successfully.

Solid oxidising agents are also used, e.g. a calcium oxide scrubber, where particulate calcium oxide is put into contact with the odorous gas stream producing a solid residue of calcium carbonate. A limited odour removal performance and severe operational problems in terms of solids handling are reported. It is, therefore, more common for only liquid absorbing agents to be used.

2.1.6.2.4 Biological treatment

The process of using microorganisms to break down airborne odour emissions is used extensively. The reaction speed of the biodegradation process is relatively low and optimising operating conditions can have a crucial influence.

There are two types of biological treatment, biofilters (see Section 2.3.7.3.4) and bioscrubbers (see Section 2.3.7.3.5). The most popular type of biological treatment is the biofilter. There are a number of design considerations which need to be taken into account to ensure effective operation; these are residence time, temperature, humidity, effects of dust and fat on the filter, organic/odour load, and design and characteristics of the filter material. Advantages and disadvantages of biological treatment methods are shown in Table 2.12.

Table 2.12: Advantages and disadvantages of biological treatment

Advantages	Disadvantages
Relatively low capital cost	Restricted to wet bulb temperatures < 40 °C
Relatively low operating costs	High land area requirements
Potentially high odour removal ~ 90–99 %	Potential for visible plume formation
Simple design and operation	Requires control of pH and water content
-	Slow adaptation to fluctuating concentrations
<i>Source: [16, Willey et al. 2001]</i>	

Principle of operation

The biofilm is the water layer prevailing around individual particles of the filter material where microorganisms are present. When the airstream to be treated flows around the particles, there is a continuous mass transfer between the gas phase and the biolayer. Volatile components present in the exhaust gas, together with oxygen, are partially dissolved in the liquid phase of the biolayer. The second reaction step is the aerobic biological degradation of the components in the liquid phase. In this way, a concentration gradient is created in the biolayer which maintains a continuous mass flow of the components from the gas to the wet biolayer.

Transport across the phase boundary and diffusion into the biolayer provide food for the microorganisms living in the biolayer. Nutrients, required for cell growth, are provided from the filter material.

2.1.6.2.5 Thermal treatment of waste gases

Certain gaseous pollutants and odour can be oxidised at high temperatures. The speed of the reaction increases exponentially with temperature. Oxidisable pollutants include all organic compounds, as well as inorganic substances such as carbon monoxide and ammonia. Given complete combustion, carbon and hydrogen react with oxygen to form CO₂ and water. Incomplete combustion can result in new pollutants such as carbon monoxide and in totally or partially unoxidised organic compounds. If the waste gas contains elements such as sulphur, nitrogen, halogens and phosphorus, combustion gives rise to inorganic pollutants such as oxides of sulphur, oxides of nitrogen and hydrogen halides, which subsequently have to be removed by means of other waste gas purification processes if the concentrations are too high. This restricts the field of applications for the combustion of pollutants.

There are a number of safety requirements, in particular:

- The need for protection against flame flashback between the thermal oxidiser and the gas stream to be treated. This can generally be achieved via a flame arrestor or water seal.
- On start-up, before the burner is ignited, the thermal oxidiser needs to be purged with air by a volume equivalent to five times the plant volume. Any re-ignition of burners during the operation is preceded by a burner purge period.
- When the air is rich in solvents, a risk assessment is required.

2.1.6.3 Odour

Odour is mostly a local problem. Some emissions to air which are harmful may also be odorous. For two identical installations producing the same products and using the same raw materials and process operations, one may be subject to considerable complaints whilst for the other the odour emission may not be a problem. There are many cases where installations, previously situated in rural areas on the outskirts of a town or city, are now faced with odour problems as new housing estates have been constructed near the site as the town has grown. Odour problems are usually related to waste water treatment operations. Ammonia used in cooling systems may leak or accidental releases may occur which also result in odour complaints.

In the vast majority of countries, odour emissions are regulated under the laws of nuisance. Some countries have quantified legislation. This quantified legislation can relate to either the magnitude of the odorous emission or alternatively to a maximum concentration of a component or group of components which are known to cause odorous emissions. The internationally accepted units of odour are odour units per cubic metre (OU_E/m^3). Instrumental odour measurements exist but the quantification of odour is still based on olfactometry to a great extent.

In Germany for example, the legislation for odorous processes is largely directed towards ensuring that the outlet concentration of organics is only related to the process being conducted and the efficiency of the chosen abatement plan. The legislation, under TA Luft, contains a general statement about odour emissions and describes the need to consider containment, the surroundings and the ability of the abatement plan to achieve 99 % odour reduction for odour emissions greater than $100\,000 \text{OU}_E/\text{m}^3$. For specific process operations TA Luft provides maximum outlet concentrations of organics that should not be exceeded.

The Netherlands considers odour to be a local matter, which needs an immission-based approach, based on the local situation (e.g. emission concentration, distance to sensitive objects, stack height) and the nature of the odour (hedonic value).

For odour, an acceptable solution is to reduce the impact on the surroundings by emission through a suitable stack. However, in many cases, this is not enough and other abatement systems should be applied [161, Nordic Council of Ministers 2016].

Dispersion is sometimes used via existing installations on the site, e.g. using a high discharge boiler stack. The legislation governing odorous emissions, if they are not also considered to be harmful, is impact-related and not source-controlled. This means that the need to treat an odorous emission is governed by the impact it has on the surrounding environment following dispersion in the air. Controls of the dispersion of the emission to air typically consider both the prevention of complaints as well as legal requirements associated with odour emissions and their composition, e.g. if they contain VOC.

For example, reduced ground level concentrations could be achieved without any reduction in the magnitude of the odour emission, but merely by enhancing its dispersion in the air. Adding a perfumed component, i.e. a masking agent, is another option for physically treating the odour, but it is not recommended.

The dispersion of an exhaust emission in the air, and hence its resultant ground level odour concentration, will depend upon a variety of factors, including:

- the prevailing climatic conditions;
- the height of the discharge;
- positioning of nearby buildings or structures;
- stack temperature (thermal buoyancy) and discharge velocity;
- configuration of the discharge stack.

With the exception of the prevailing climatic conditions, all of the aforementioned factors can be altered with the desired intention of improving the dispersion potential of the discharge. The influence of the above factors can be examined in a computer-based dispersion model which incorporates these factors in the computation of ground-level odour concentrations. The model allows the sensitivity of stack height or increases to the discharge velocity to be quantitatively judged related to resultant ground-level concentrations.

The computer-based air dispersion models are not described in this document. There are also equations available to calculate optimum stack characteristics and these can be determined without using an expensive air dispersion model. These procedures can be used as a guideline and can, therefore, be used as an initial check to see whether increases to either the stack height or stack velocity are possible. The practicality of carrying out such changes can also be assessed.

2.1.6.4 Emissions to air control strategy

The strategy is divided into a number of evaluation stages. The extent to which each stage needs to be applied depends on the particular installation situation and certain stages may or may not be required to achieve the levels of protection sought. The strategy can be used for all emissions to air, i.e. gases, dust and odours, some of which are caused by VOC emissions. Odour is mainly a local issue based on nuisance but, as it often arises due to the emission of VOC, these also need to be considered. For each stage, odour is used as an illustrative example. The approach of this example, summarised in Figure 2.4, is particularly useful for large operating sites where there are a high number of discrete odour sources and where the major contributors to the overall odorous discharge are not fully understood.

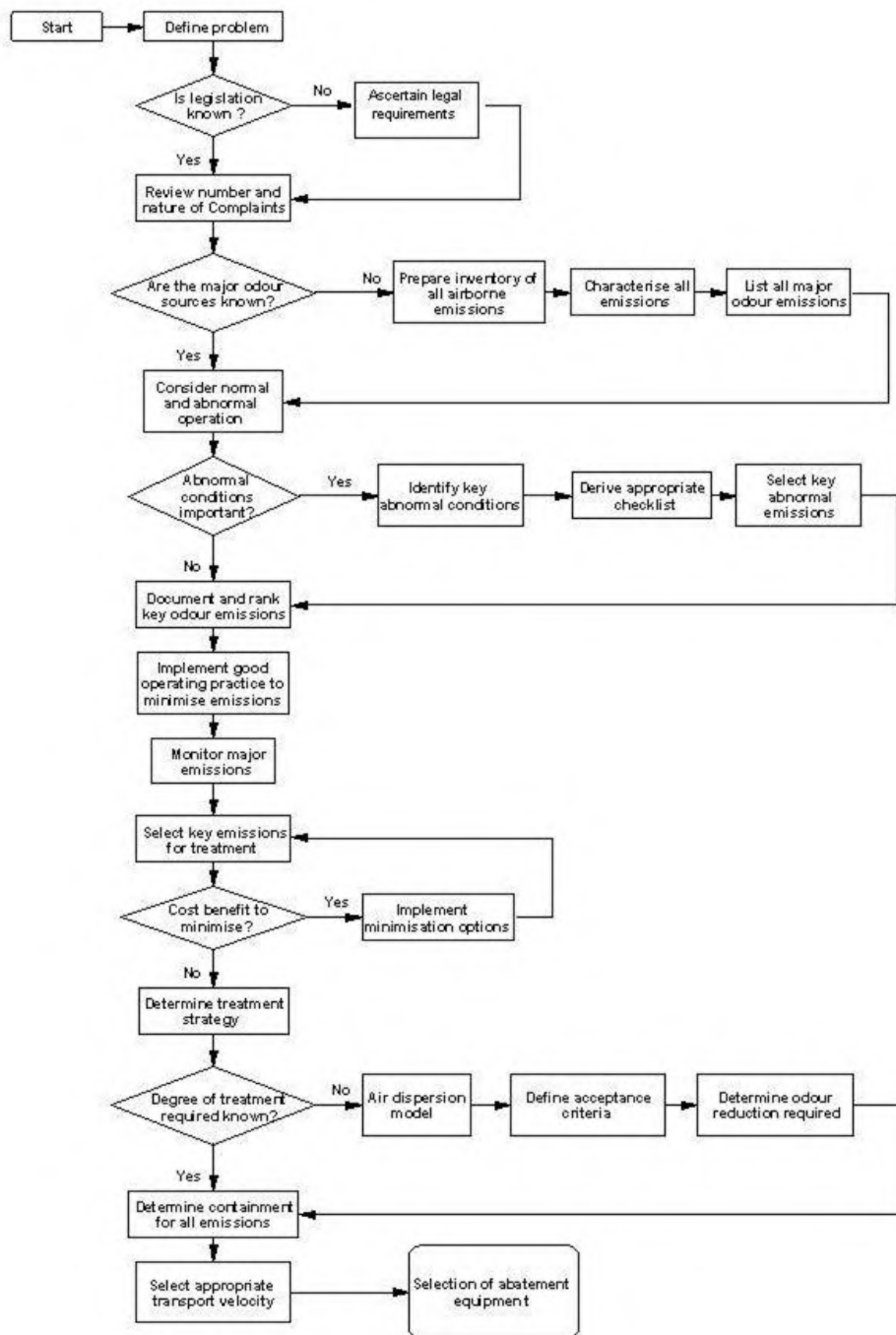

Source: [16, Willey et al. 2001]

Figure 2.4: Flow chart for the selection of odour abatement techniques

2.1.6.4.1 Step 1: Definition of the problem

Information is gathered about legislative requirements regarding emissions to air. The local setting, e.g. weather and geographical conditions, may also be relevant when defining the problem, for example for odour.

2.1.6.4.1.1 Odour example

People working at the installation will generally be well aware of what the odour problems are and can assist a consultant or person unfamiliar with the local situation.

First, the number and frequency of complaints and the characteristics related to odour can be reviewed. The location of the complainants related to the installation, together with any comments made by the complainants or the local authority representatives, help to identify what needs to be addressed. A complaints logging system can be set up, which includes a system for answering all complaints made directly to the installation with either a telephone call or personal visit. If the exact processing conditions at the time of the complaint are examined and documented, this can assist in locating the odour sources which need to be controlled.

Any correspondence with the local authority or the local community can be reviewed. The level of activity of the local community, together with the approach and actions taken by the local authority representatives, can enable the severity of the problem to be established and influence the likely timescale available to modify the process or install an abatement plant.

Finally, the prevailing local climatic conditions can be established. In particular, the prevailing wind direction and wind speed and the frequency of inversions. This information can be used to ascertain whether the complaints are largely generated as a result of certain weather conditions or are generated by specific operations carried out at the installation.

2.1.6.4.2 Step 2: Inventory of site emissions

The inventory includes normal and abnormal operational emissions. Characterising each emission point allows subsequent comparison and ranking with other site emission points.

A systematic way to identify normal operational emissions to air is to work through each process and identify all potential emissions. For example, this study may cover from raw material delivery and storage, production to packaging and palletising/warehousing.

The study can be conducted with varying degrees of sophistication. Process flow sheets or process and instrumentation diagrams can be used during a tour around the site to systematically identify all the emission sources.

Depending on the severity of the problem and the key site operations that cause the problem, it may be necessary to extend this analysis to cover abnormal and even emergency situations.

2.1.6.4.2.1 Odour example

It is important to fully evaluate the range of odorous emissions from the site and to identify the discrete emissions with the greatest potential to cause odour complaints.

Table 2.13 shows one way of recording information of normal operational odour sources. It may be the case that odour problems only arise during abnormal operations. A typical checklist for abnormal operations is shown in Table 2.14.

Table 2.13: Data sheet for collecting information on odorous emissions

Odour source	Examples
Type of discharge	Forced/natural/ventilation
Process operation conducted	Heating/cooling/maintenance/cleaning
Continuity of emission	Continuous/discontinuous/periodic
Operational time	Duration per hour/per day/per production cycle
Discharge arrangement	Stack/manhole/in building/atmospheric
Discharge configuration	Stack diameter/elevation of discharge
Description of odour	Sweet/sour/pungent/fruity
Strength of odour	Very faint/faint/distinct/strong/very strong
Estimated flow rate	Measurement/fan curves/estimate
Location in installation site	Coordinates of discharge
Operation	Normal/abnormal/emergency
Overall ranking	e.g. -10 to +10 or 0 to 10
<i>Source: [192, COM 2006]</i>	

Table 2.14: Checklist for abnormal operation

Parameter	Examples
Loss of containment	Overfilling/leaks/failure control
Disposal emptying	Waste materials and process materials
Potential for material to enter process	Steam coil breakage
Runaway reaction	Failure to input a material or to control temperature
Corrosion/erosion	Inspection frequency
Loss of services	Fail-safe instrumentation
Control/manning	Level of control and supervision
Ventilation/extraction	Design basis correct
Maintenance/inspection	Frequency, what is required?
Start-up/shutdown	Implications for downstream operations
Throughput changes	100 %, 110 % of production + low production
Formulation changes	Odorous ingredients
<i>Source: [192, COM 2006]</i>	

The odorous emissions can be ranked in terms of the severity of their impact on the surrounding environment. A possible system to devise a ranking order could start with grouping the emissions into categories such as major, medium and minor according to their odour characteristics and the related complaints. The ranking within each category is strongly influenced by the strength of the perceived odour from the source together with the associated airflow and nature of operation, i.e. continuous or non-continuous. This process may require a degree of professional judgement in addition to the factors detailed above.

2.1.6.4.3 Step 3: Measurement of major emissions

Emissions to air are quantified for determining priorities for prevention and treatment. The measurement will allow the emissions to be ordered in terms of the magnitude of their impact.

2.1.6.4.3.1 Odour example

The quantification of the major odorous emissions is undertaken using the following formula:

$$\text{Odour emission (OU}_E\text{/s)} = \text{measured odour level (OU}_E\text{/m}^3\text{)} \times \text{associated volumetric airflow (m}^3\text{/s)}$$

Odour measurement is difficult and the results may have a wide statistical deviation. Nevertheless, a quantitative measurement of odour may ultimately be required by a contractor supplying abatement equipment or to demonstrate compliance with legislation.

If the key odorous emissions are known, together with the related flow rates and with the physical location of the emissions within the site, this will allow a possible treatment scenario to be developed. Table 2.15 is based on a real but unspecified situation simplified to illustrate the principle. It shows the calculation of odour emissions and, based on this level, this technique proposes an emission ranking.

Table 2.15: A typical odour measurement programme using simplified measurements from an unspecified food manufacturing site

Source	Flow rate (m ³ /s)	Odour level (OU _E /m ³)	Odour emission (OU _E /s)	Emission ranking based on the odour emission*	Operational hours (h/yr)
Raw material handling	180 000	1 610	22	5	480
Raw material heating	172 800	1 250	16	6	960
Process heating	3 960	11 290	3.4	7	2 100
Vacuum generation	1 440 000	17 180	1 909	2	5 760
Fat trap	5 760	90	0.04	8	6 240
Vent to air from process plant	6 912 000	350	190	4	48
Packing hall	45 720 000	80	275	3	5 760
Waste facility	12 600 000	2 690	2 611	1	387
* This does not take account of odour impact, exposure times or other characteristics. Number 1 has the highest priority for treatment as it has the highest emission level, down to 8 which is the lowest.					
Source: [16, Willey et al. 2001]					

Air dispersion modelling can enable the impact of the major measured emissions to be fully quantified. The impact, in this respect, is the resultant ground-level odour concentration of the total emissions from the site at varying distances from the site boundary related to climatic conditions, to determine any required action to control odour emissions. If there are several odours or components from the same source, which is usually the case, these may all be considered together. If there is more than one odour source, it is necessary to consider each one separately.

2.1.6.4.4 Step 4: Selection of air emission control techniques

An inventory of emissions, immissions and complaints, e.g. in the case of odour, which often arises due to the emission of VOC, can identify the major sources of emissions to air from the site that need to be part of a treatment plan or strategy. It enables any sources whose impact can be eliminated or, if not, reduced to be identified. Control techniques include process-integrated and end-of-pipe treatment.

Process-integrated treatment includes substance-related measures, such as selecting substitutes for harmful substances such as carcinogens, mutagens or teratogens; using low-emission materials, e.g. low-volatility liquids and low-fine dust solids and process-related measures, such as using low-emission systems and production processes. If, after applying process-integrated measures, emission reduction is still required, further control of gases, odour/VOC and dust by the application of end-of-pipe techniques may be needed.

When selecting odour abatement techniques, the first stage is to analyse the flow rate, temperature, humidity, and the particulate and contaminant concentrations of the odorous emission. Odours often arise due to the emissions of VOC, in which case the abatement technique applied needs to take account of toxic and flammable hazards. A summary of generalised criteria for selecting odour/VOC abatement techniques is shown in Table 2.16, where these parameters are shown in a matrix against some generic types of abatement equipment available. Table 2.16 is a guideline and does not contain the full details about the advantages and limitations of individual techniques. Each property of the odorous emission has been segregated into two or three ranges. In this example, flow rate is segregated into two ranges, i.e. above and below 10 000 m³/h. Each cell in the matrix has been assigned a value of between 0 and 3, with a value of 3 representing the optimum operating condition.

For each of the abatement techniques, the relevant range of each of the odorous emission properties is totalled. This allows a simple ranking system, by which the techniques with the highest scores are considered further. Typically, three to five abatement techniques are carried forward to the next stage in the selection procedure.

Table 2.16: Summary of generalised criteria for selecting odour/VOC abatement techniques

Treatment	Flow rate (m ³ /h)		Temperature (°C)		Relative humidity (%)		Particulate (mg/Nm ³)		Contaminant concentration (mg/Nm ³)			Score
	< 10 000	> 10 000	< 50	> 50	< 75	> 75	0	< 20	> 20	< 500	> 500	
Physical	1	2	1	2	2	1	1	1	2	1	0	
Absorption-water	1	1	2	1	2	1	1	1	3	1	0	
Absorption-chemical	2	2	2	1	2	1	2	1	1	2	1	
Adsorption	3	1	3	0	2	0	3	0	0	2	1	
Biological	3*	2*	3	0	2	2	3	1	0	3	0	
Thermal oxidation	3	1	1	3	2	1	3	2	1	3	3	
Catalytic oxidation	3	2	1	3	2	1	3	0	0	3	3	
Plasma	2	3	3	1–2	3	2	3	3	1–2	3	2	
Score rating	Description											
0	This treatment is not suitable or unlikely to be effective, so is not considered as part of the selection procedure.											
1	Worthwhile considering although unlikely to be the best choice											
2	The abatement technique is well suited for this condition											
3	Represents the best operating condition for the given treatment system											
*	Depends on the surface area											

Source: [16, Willey et al. 2001]

The effectiveness or required performance is considered next. This can be assessed using professional guidance and information from the manufacturers of the abatement techniques. The next step in the selection procedure is a feasibility assessment. The capital and operating costs,

space requirements and whether the abatement technique has been proven to be applicable in a similar process are all considered. Figure 2.5 shows a flow sheet that summarises this process of selecting end-of-pipe odour/VOC abatement techniques.

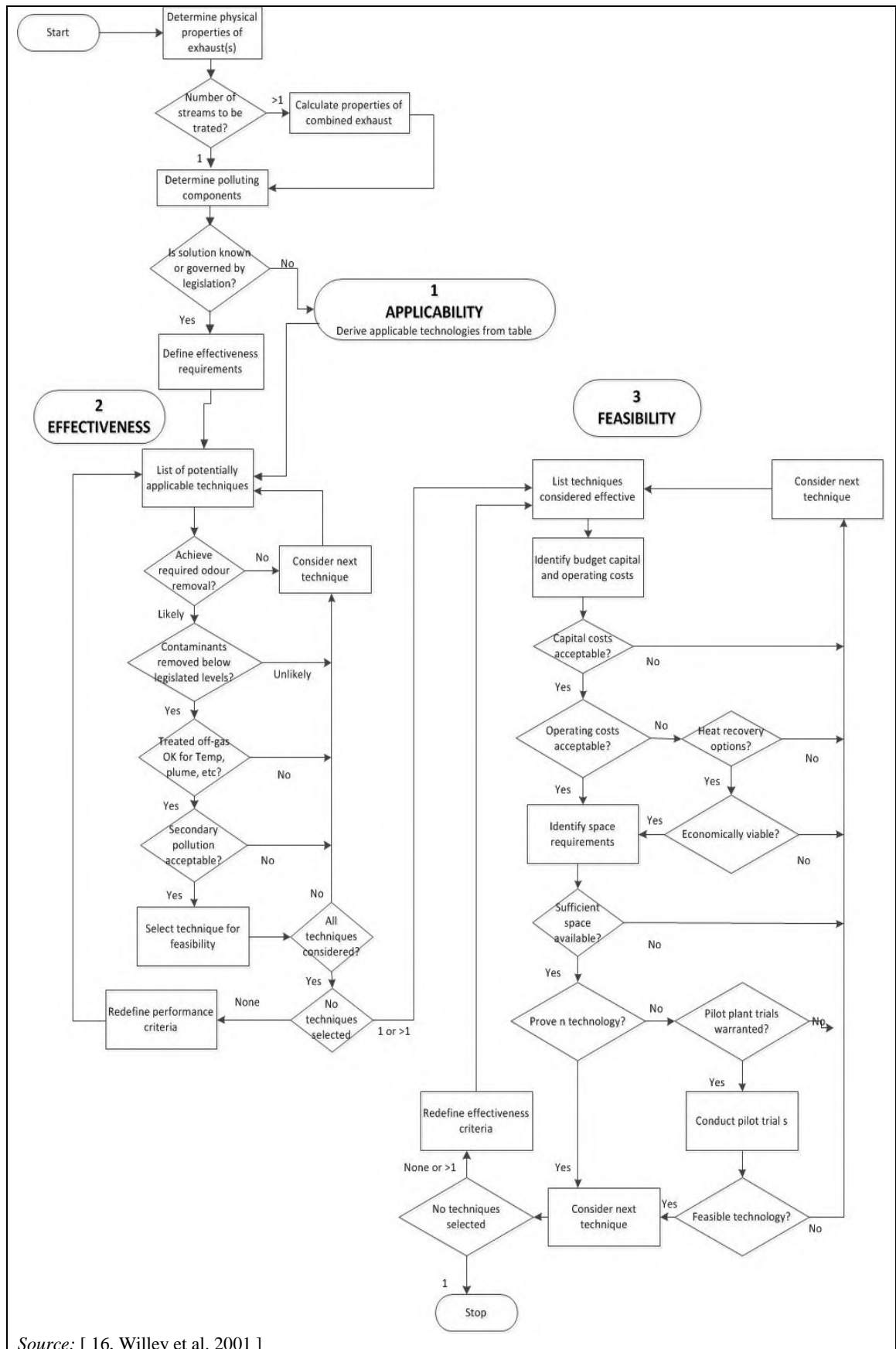

Source: [16, Willey et al. 2001]

Figure 2.5: Flow sheet for the selection of odour abatement equipment

2.1.7 Accidental release

One potential environmental impact associated with a FDM installation is an accident which could pollute the environment. This is usually characterised by an accidental release of material directly to air, water or land, although it may also be a failure that leads to the generation of otherwise avoidable waste. For example, the accidental release of the contents of a tank containing raw material such as milk, or product such as vegetable oil, or an auxiliary material such as ammonia can have a significant detrimental impact on a local watercourse or water supply. Such accidents may occur during routine or non-routine operations.

There are a number of stages in the management of accidental releases:

- identify potential accidents that could pollute the environment;
- conduct a risk assessment on the identified potential accidents to determine their probability of occurrence and potential specific type and severity of harm to the environment;
- develop control measures to prevent, eliminate or reduce, to an acceptable level, the risks associated with identified potential accidents;
- develop and implement an emergency plan;
- investigate all accidents and near misses, to identify their causes and take action to prevent recurrence.

2.2 Current consumption and emission levels across the FDM sector

2.2.1 Energy consumption

Data on specific energy consumption are available in the sectorial chapters. The TWG considered the data of specific energy consumption as confidential. The calculation of specific energy consumption is based on the following equation:

$$\text{specific energy consumption} = \frac{\text{final energy consumption}}{\text{activity rate}}$$

where:

Final energy consumption is the total amount of energy consumed by the specific processes concerned during the production period (in the form of heat and electricity), expressed in MWh/year.

Activity rate is the total amount of products or raw materials processed, depending on the specific sector, expressed in tonnes/year or hl/year. Packaging is not included in the weight of the product. Raw material is any material entering the plant, treated or processed for the production of food or feed.

2.2.2 Water consumption

Water consumption is one of the key environmental issues for the FDM sector. Water has many different uses, e.g.:

- for cooling and cleaning;
- as a raw material, especially for the drinks industry;
- as process water, e.g. for washing raw materials, intermediates and products;
- for cooking, dissolving and for transportation;
- for cleaning of packaging materials;
- as auxiliary water, e.g. for the production of vapour and vacuum;
- as sanitary water.

The quality of water needed depends on the specific use.

Generally, large quantities of water are required for cleaning and disinfection. In many installations, this is the main consumer of water, with the amount depending on the type and size of equipment to be cleaned and the materials processed. Cleaning and disinfection produces waste water. This typically contains soluble organic material, FOG, TSS, nitrate, nitrite, ammonia and phosphate from product remnants and removed deposited soil. It also contains residues of cleaning agents, e.g. acid or alkali solutions. In principle, the cleaning and disinfection agents that are used are discharged via the waste water, either in their original state or as reaction products.

Ranges of specific water consumption at installation level are available in each specific chapter of this BREF. The TWG considered the data of specific water consumption as confidential. The calculation of specific water consumption is based on the following equation:

$$\text{specific water consumption} = \frac{\text{water consumption}}{\text{activity rate}}$$

where:

Water consumption is the total amount of water consumed by the specific processes concerned during the production period, expressed in m³/year excluding:

- the total amount of recycled/reused water;
- the cooling water and run-off water that are not reused and are discharged separately from process water.

Activity rate is the total amount of all products (or all raw materials, depending on the specific sector), expressed in tonnes/year or hl/year. Packaging is not included in the weight of the product. Raw material is any material entering the plant, treated or processed for the production of food or feed.

Water recycling and/or reuse is a common technique in all FDM sectors. Raw materials in some FDM sectors (e.g. dairies, starch production, sugar manufacturing) are characterised by the high water content that is released. In these specific sectors, the amount of reused water can be several times the amount of water consumption. An indicative list of ways for recycling and/or reusing water is given in Section 2.3.3.1.1.

2.2.3 Waste water discharge

The FDM sector has traditionally been a large user of water as an ingredient, cleaning agent, means of conveyance and feed to utility systems. Large FDM processing installations can use several hundred cubic metres of water a day. Most of the water not used as an ingredient ultimately appears in the waste water stream.

Substantial reductions in the volume of waste water generated in this sector can be achieved through waste minimisation techniques (see for example Section 2.3.5). There is no simple relationship between the amount of water used in cleaning and hygiene standards, and food safety legislation requirements prevent water use minimisation from causing unsatisfactory levels of cleanliness, hygiene or product quality.

Waste water flow rates may be very variable on a daily, weekly or seasonal basis. The waste water profile is largely dependent on production and cleaning patterns. In some sectors, e.g. sugar beet and olive oil production, processing takes place on a campaign basis and there is little or no waste water generated for part of the year.

FDM waste water is extremely variable in composition. It is, however, typically high in both COD and BOD. Emission levels can be 10–100 times higher than those of domestic waste water.

Ranges of emission data on yearly average concentrations and specific loads for different parameters in the effluent of the WWTP by FDM sector and type of discharge for the installations are shown from Table 2.17 to Table 2.32. The ranges of abatement efficiencies of the WWTP for each parameter are shown in Table 2.33. The emission data sets for different parameters and for specific plants are shown in Section 2.3.6.8. The TWG considered the emission data expressed in specific loads as confidential.

Table 2.17: Ranges of yearly average concentrations of COD in the effluent of the WWTP

FDM sector	Yearly average COD concentration (mg/l)		
	Direct discharge	Indirect discharge	Landspreading
Animal feed	19–155	778–8 890	NI
Brewing	16–85	111–5 779	NI
Dairies	8–147	40–4 475	20–1 001
Ethanol production	41–65	NI	NI
Fish and shellfish processing	NI	5 741	NI
Fruit and vegetables	13–187	33–2 319	2 205–5 402
Grain milling	NI	NI	NI
Meat processing	22–259	406–3 800	1 059–1 692
Oilseed processing and vegetable oil refining	15–363	53–5 561	NI
Olive oil processing and refining	NI	53–645	NI
Soft drinks and nectar/juice	6–78	1 537–3 253	3 322–3 459
Starch production	31–284	72–78	513–11 333
Sugar manufacturing	22–132	1 560–4 675	5 556
All FDM sectors	6–363	40–8 890	20–11 333
NB: NI = no information provided. Source: [193, TWG 2015]			

Table 2.18: Ranges of yearly average specific loads of COD in the effluent of the WWTP

FDM sector	Yearly average COD specific load			
	Unit	Direct discharge	Indirect discharge	Landspreading
Animal feed	g/t raw materials	85	403–4 778	NI
Brewing	g/hl products	4.4–40.2	11–1 595	NI
Dairies	g/t raw materials	0.8–649	28–18 631	74–1 258
Ethanol production	g/t products	5.1	NI	NI
Fish and shellfish processing	g/t raw materials	NI	NI	NI
Fruit and vegetables	g/t products	16–2 489	37	15 457–35 541
Grain milling		NI	NI	NI
Meat processing	g/t raw materials	80–609	831–11 363	NI
Oilseed processing and vegetable oil refining	g/t products	0.01–221	108–4 984	NI
Olive oil processing and refining		NI	NI	NI
Soft drinks and nectar/juice	g/hl products	0.7–4	170	390
Starch production	g/t raw materials	78–1 127	NI	572–23 743
Sugar manufacturing		29–2 059	3 618	5 940
NB: NI = no information provided. Source: [193, TWG 2015]				

Table 2.19: Ranges of yearly average concentrations of TOC in the effluent of the WWTP

FDM sector	Yearly average TOC concentration (mg/l)		
	Direct discharge	Indirect discharge	Landspreading
Animal feed	NI	357–421	NI
Brewing	NI	50–911	NI
Dairies	3.7–7.2	116–1 131	NI
Ethanol production	NI	NI	NI
Fish and shellfish processing	NI	NI	NI
Fruit and vegetables	15	NI	NI
Grain milling	NI	NI	NI
Meat processing	15.8–22.2	NI	NI
Oilseed processing and vegetable oil refining	NI	310–970	NI
Olive oil processing and refining	NI	NI	NI
Soft drinks and nectar/juice	6–13.7	480–2 733	NI
Starch production	19.5–116	NI	NI
Sugar manufacturing	1.3–28.2	NI	1 433–1 931
All FDM sectors	1.3–116	50–2 733	1 433–1 931
NB: NI = no information provided. Source: [193, TWG 2015]			

Table 2.20: Ranges of yearly average specific loads of TOC in the effluent of the WWTP

FDM sector	Yearly average TOC specific load			
	Unit	Direct discharge	Indirect discharge	Landspreading
Animal feed	g/t raw materials	NI	1 363	NI
Brewing	g/hl products	NI	14.7–254	NI
Dairies	g/t raw materials	8.95	299–1 568	NI
Ethanol production	g/t products	NI	NI	NI
Fish and shellfish processing	g/t raw materials	NI	NI	NI
Fruit and vegetables	g/t products	220	NI	NI
Grain milling		NI	NI	NI
Meat processing	g/t raw materials	25.15	NI	NI
Oilseed processing and vegetable oil refining	g/t products	NI	178	NI
Olive oil processing and refining		NI	NI	NI
Soft drinks and nectar/juice	g/hl products	NI	NI	NI
Starch production	g/t raw materials	NI	NI	NI
Sugar manufacturing		3.23–10.01	NI	NI
NB: NI = no information provided. Source: [193, TWG 2015]				

Table 2.21: Ranges of yearly average concentrations of BOD₅ in the effluent of the WWTP

FDM sector	Yearly average BOD ₅ concentration (mg/l)		
	Direct discharge	Indirect discharge	Landspreading
Animal feed	3.3–40	650–801	NI
Brewing	2–11.5	200–4 000	NI
Dairies	0.5–30.7	8.35–2 825	5.6–10.2
Ethanol production	2.2–5.7	NI	NI
Fish and shellfish processing	NI	NI	NI
Fruit and vegetables	1.2–56.5	1 125–1 593	2 711–5 054
Grain milling	NI	NI	NI
Meat processing	2.7–110.7	392–1 446	NI
Oilseed processing and vegetable oil refining	2–44	5–1 800	NI
Olive oil processing and refining	NI	120–750	NI
Soft drinks and nectar/juice	2.8–23.3	376	1 437–1 599
Starch production	1.8–84	20.75	232–335
Sugar manufacturing	1.6–143	345–1 625	2 948–4 210
All FDM sectors	0.5–143	5–4 000	5.6–5 054

NB: NI = no information provided.
Source: [193, TWG 2015]

Table 2.22: Ranges of yearly average specific loads of BOD₅ in the effluent of the WWTP

FDM sector	Yearly average BOD ₅ specific load			
	Unit	Direct discharge	Indirect discharge	Landspreading
Animal feed	g/t raw materials	14.74	NI	NI
Brewing	g/hl products	0.63–4.46	10.9–482.1	NI
Dairies	g/t raw materials	0.2–74.6	32–5 058	20.95
Ethanol production	g/t products	31.46	NI	NI
Fish and shellfish processing	g/t raw materials	NI	NI	NI
Fruit and vegetables	g/t products	1.99–744.1	17.79	9 715–20 863
Grain milling		NI	NI	NI
Meat processing	g/t raw materials	17.6–65.1	4 906–6 823	NI
Oilseed processing and vegetable oil refining	g/t products	1.8–18.3	174.25	NI
Olive oil processing and refining		274.58	NI	NI
Soft drinks and nectar/juice	g/hl products	0.4–15.5	41.5	167
Starch production	g/t raw materials	3.9–130	NI	259
Sugar manufacturing		1–560	NI	3 152

NB: NI = no information provided.
Source: [193, TWG 2015]

Table 2.23: Ranges of yearly average concentrations of TSS in the effluent of the WWTP

FDM sector	Yearly average TSS concentration (mg/l)		
	Direct discharge	Indirect discharge	Landspreading
Animal feed	4.6–97	91–303	NI
Brewing	2.5–21	1.6–1 095	NI
Dairies	0.6–41.4	18–1 095	NI
Ethanol production	NI	NI	NI
Fish and shellfish processing	NI	2 814–3 633	NI
Fruit and vegetables	3–65.3	5.1–84	301–1 132
Grain milling	NI	NI	NI
Meat processing	0.02–51.2	135–1 440	254–481
Oilseed processing and vegetable oil refining	0.02–166	0.15–153	NI
Olive oil processing and refining	NI	130–300	NI
Soft drinks and nectar/juice	0.05–34.4	29–1 341	88–163
Starch production	5–42.8	29–53	130–5 107
Sugar manufacturing	0.04–128	660–980	3 148–5 281
All FDM sectors	0.02–166	0.15–3 633	88–5 281
NB: NI = no information provided. Source: [193, TWG 2015]			

Table 2.24: Ranges of yearly average specific loads of TSS in the effluent of the WWTP

FDM sector	Yearly average TSS specific load			
	Unit	Direct discharge	Indirect discharge	Landspreading
Animal feed	g/t raw materials	21.8	675.3	NI
Brewing	g/hl product	1.05–11.73	4.81–279.21	NI
Dairies	g/t raw materials	0.04–299	87–2 572	3.52
Ethanol production	g/t product	NI	NI	NI
Fish and shellfish processing	g/t raw materials	NI	NI	NI
Fruit and vegetables	g/t products	3.43–902	1.32	2 110–7 448
Grain milling		NI	NI	NI
Meat processing	g/t raw materials	0.22–64	206–2 134	1 377
Oilseed processing and vegetable oil refining	g/t products	0.006–63.13	19–681	NI
Olive oil processing and refining		NI	NI	NI
Soft drinks and nectar/juice	g/hl products	0.008–26.94	NI	10.22
Starch production	g/t raw materials	11–476	NI	348
Sugar manufacturing		6–535	NI	4 299
NB: NI = no information provided. Source: [193, TWG 2015]				

Table 2.25: Ranges of yearly average concentrations of NH₄-N in the effluent of the WWTP

FDM sector	Yearly average NH ₄ -N concentration (mg/l)		
	Direct discharge	Indirect discharge	Landspreading
Animal feed	1–7.4	56.3	NI
Brewing	0.03–3.96	0.7–48.7	NI
Dairies	0.03–8.75	1.3–160	NI
Ethanol production	0.5–1.9	NI	NI
Fish and shellfish processing	NI	NI	NI
Fruit and vegetables	0.06–4.83	0.17–0.54	NI
Grain milling	NI	NI	NI
Meat processing	0.08–9.12	1.6–5.7	0.39–1.11
Oilseed processing and vegetable oil refining	0.6–3.1	1.32–82	NI
Olive oil processing and refining	NI	NI	NI
Soft drinks and nectar/juice	0.04–1.24	0.3–0.7	NI
Starch production	0.14–18	NI	0.92–47
Sugar manufacturing	0.06–8.68	NI	4–17
All FDM sectors	0.03–18	0.7–160	0.39–47
NB: NI = no information provided. Source: [193, TWG 2015]			

Table 2.26: Ranges of yearly average specific loads of NH₄-N in the effluent of the WWTP

FDM sector	Yearly average NH ₄ -N specific load			
	Unit	Direct discharge	Indirect discharge	Landspreading
Animal feed	g/t raw materials	9.38	NI	NI
Brewing	g/hl products	0.01–0.088	0.19–4.78	NI
Dairies	g/t raw materials	0.009–17.73	5.9–173.2	NI
Ethanol production	g/t products	3.76–10.48	NI	NI
Fish and shellfish processing	g/t raw materials	NI	NI	NI
Fruit and vegetables	g/t products	0.73–50.10	0.002	NI
Grain milling		NI	NI	NI
Meat processing	g/t raw materials	8.7	NI	NI
Oilseed processing and vegetable oil refining	g/t products	0.49–0.5	16.38	NI
Olive oil processing and refining		NI	NI	NI
Soft drinks and nectar/juice	g/hl products	0.01–0.37	NI	NI
Starch production	g/t raw materials	2.32	NI	NI
Sugar manufacturing		0.05–2.95	NI	4.27
NB: NI = no information provided. Source: [193, TWG 2015]				

Table 2.27: Ranges of yearly average concentrations of TN in the effluent of the WWTP

FDM sector	Yearly average TN concentration (mg/l)		
	Direct discharge	Indirect discharge	Landspreading
Animal feed	2.4–12	89–231	NI
Brewing	4.8–25	26.5–81.5	NI
Dairies	1.1–23.4	38–214	4.2–111
Ethanol production	NI	NI	NI
Fish and shellfish processing	NI	NI	NI
Fruit and vegetables	0.4–22.8	10.2–14.8	9–105
Grain milling	NI	NI	NI
Meat processing	2.4–17.9	33–358	25.6–53
Oilseed processing and vegetable oil refining	0.9–15.3	2.5–110	NI
Olive oil processing and refining	NI	4–7	NI
Soft drinks and nectar/juice	1.3–4.1	5–10	11.7–16.4
Starch production	3–13.4	3.3–5.3	55–2 150
Sugar manufacturing	1.7–26.3	21.5–265	74–94
All FDM sectors	0.4–26.3	2.5–358	4.2–2 150
NB: NI = no information provided. Source: [193, TWG 2015]			

Table 2.28: Ranges of yearly average specific loads of TN in the effluent of the WWTP

FDM sector	Yearly average TN specific load			
	Unit	Direct discharge	Indirect discharge	Landspreading
Animal feed	g/t raw materials	10.72	21.18	NI
Brewing	g/hl products	0.30–2.79	1.05–22.64	NI
Dairies	g/t raw materials	0.57–40.68	43–1 241	15.46
Ethanol production	g/t products	4.8–14.9	NI	NI
Fish and shellfish processing	g/t raw materials	NI	NI	NI
Fruit and vegetables	g/t products	2.33–619	0.16	63–159
Grain milling		NI	NI	NI
Meat processing	g/t raw materials	20–58	811	NI
Oilseed processing and vegetable oil refining	g/t products	0.60–17.07	3.56–36.24	NI
Olive oil processing and refining		NI	9.15	NI
Soft drinks and nectar/juice	g/hl products	0.17– 2.77	NI	1.36
Starch production	g/t raw materials	5.6–71.3	NI	860
Sugar manufacturing	g/t raw materials	1.61–25.81	NI	91.94
NB: NI = no information provided. Source: [193, TWG 2015]				

Table 2.29: Ranges of yearly average concentrations of TP in the effluent of the WWTP

FDM sector	Yearly average TP concentration (mg/l)		
	Direct discharge	Indirect discharge	Landspreading
Animal feed	0.25–2.82	2.76–118	NI
Brewing	0.5–4.3	1.4–89	NI
Dairies	0.09–6.27	3.18–75	0.14–1.3
Ethanol production	0.8–1.1	NI	NI
Fish and shellfish processing	NI	NI	NI
Fruit and vegetables	0.18–16	2.19–22.27	2–23
Grain milling	NI	NI	NI
Meat processing	0.43–6.21	3.91–47.15	5.1–9.4
Oilseed processing and vegetable oil refining	0.03–39	0.74–2 655	NI
Olive oil processing and refining	NI	6–12	NI
Soft drinks and nectar/juice	0.13–2.4	18–30	2.14–3.27
Starch production	0.2–4.8	0.85–2.37	4.4–380
Sugar manufacturing	0.03–2.7	1.4–2	10–14
All FDM sectors	0.03–39	0.74–2 655	0.14–380
NB: NI = no information provided. Source: [193, TWG 2015]			

Table 2.30: Ranges of yearly average specific loads of TP in the effluent of the WWTP

FDM sector	Yearly average TP specific load			
	Unit	Direct discharge	Indirect discharge	Landspreading
Animal feed	g/t raw materials	NI	7.85	NI
Brewing	g/hl products	0.19–0.91	2.25–550	NI
Dairies	g/t raw materials	0.25–12.81	6.7–550	0.52 and 1.6
Ethanol production	g/t products	0.58	NI	NI
Fish and shellfish processing	g/t raw materials	NI	NI	NI
Fruit and vegetables	g/t products	0.7–99.61	0.03	14.02–35.05
Grain milling		NI	NI	NI
Meat processing	g/t raw materials	7.03–11.93	142–150	NI
Oilseed processing and vegetable oil refining	g/t products	0.02–8.07	1.15–21.94	NI
Olive oil processing and refining		13.72	NI	NI
Soft drinks and nectar/juice	g/hl products	0.029–1.55	NI	0.24
Starch production	g/t raw materials	0.28–24.04	NI	7.82–284
Sugar manufacturing		0.08–2.55	NI	14.96
NB: NI = no information provided. Source: [193, TWG 2015]				

Table 2.31: Ranges of yearly average concentrations of Cl⁻ in the effluent of the WWTP

FDM sector	Yearly average Cl ⁻ concentration (mg/l)		
	Direct discharge	Indirect discharge	Landspreading
Animal feed	NI	NI	NI
Brewing	NI	60.49	NI
Dairies	153–687	78–1 569	167
Ethanol production	NI	NI	NI
Fish and shellfish processing	NI	2 879	NI
Fruit and vegetables	NI	NI	NI
Grain milling	NI	NI	NI
Meat processing	NI	969	NI
Oilseed processing and vegetable oil refining	NI	480–763	NI
Olive oil processing and refining	NI	NI	NI
Soft drinks and nectar/juice	NI	NI	NI
Starch production	NI	NI	NI
Sugar manufacturing	NI	NI	NI
All FDM sectors	153–687	60.49–1 569	167

NB: NI = no information provided.
Source: [193, TWG 2015]

Table 2.32: Ranges of yearly average specific loads of Cl⁻ in the effluent of the WWTP

FDM sector	Yearly average Cl ⁻ specific load			
	Unit	Direct discharge	Indirect discharge	Landspreading
Animal feed	g/t raw materials	NI	NI	NI
Brewing	g/hl products	NI	17.8	NI
Dairies	g/t raw materials	200–17 139	78–9 542	618
Ethanol production	g/t products	NI	NI	NI
Fish and shellfish processing	g/t raw materials	NI	NI	NI
Fruit and vegetables	g/t products	NI	NI	NI
Grain milling		NI	NI	NI
Meat processing	g/t raw materials	NI	6 890	NI
Oilseed processing and vegetable oil refining	g/t products	NI	NI	NI
Olive oil processing and refining		NI	NI	NI
Soft drinks and nectar/juice	g/hl products	NI	NI	NI
Starch production	g/t raw materials	NI	NI	NI
Sugar manufacturing		NI	NI	NI

NB: NI = no information provided.
Source: [193, TWG 2015]

Table 2.33: Ranges of abatement efficiencies for the WWTP in FDM installations

Parameter	Abatement efficiency (%) in FDM installations (based on yearly average data)					
	For emissions expressed in concentrations			For emissions expressed in specific loads		
	Direct discharge	Indirect discharge	Waste water landspreading	Direct discharge	Indirect discharge	Waste water landspreading
COD	40–99	18–98	73 - 96	41–99	18–98	73–96
TOC	96–99	19	NI	99	NI	NI
BOD ₅	60–99	30–83	91–98	60–99	37	91–98
TSS	38–99	10–96	99	68–99	50	99
NH ₄ -N	23–99	28–85	NI	29–99	NI	NI
TN	37–99	30–75	91	37–99	67–76	89
TP	38–99	6–39	97	49–99	NI	97
Cl ⁻	13	NI	5	13	NI	NI

NB: NI = no information provided.
Source: [193, TWG 2015]

Data on specific waste water discharge are available in the sectorial chapters. The TWG considered the data of specific waste water discharge as confidential. The calculation of specific waste water discharge is based on the following equation:

$$\text{specific waste water discharge} = \frac{\text{waste water discharge}}{\text{activity rate}}$$

where:

Waste water discharge is the total amount of waste water discharged (as direct discharge, indirect discharge and/or landspreading) by the specific processes concerned during the production period, expressed in m³/year, excluding any cooling water and run-off water that is discharged separately.

Activity rate is the total amount of products or raw materials processed, depending on the specific sector, expressed in tonnes/year or hl/year. Packaging is not included in the weight of the product. Raw material is any material entering the plant, treated or processed for the production of food or feed.

Food processing waste water varies from very acidic, i.e. pH 3.5, to very alkaline, i.e. pH 11. Factors affecting waste water pH include:

- the natural pH of the raw material;
- pH adjustment of fluming water to prevent raw material deterioration;
- use of caustic or acid solutions in processing operations;
- use of caustic or acid solutions in cleaning operations;
- acidic waste streams, e.g. acid whey;
- acid-forming reactions in the waste water, e.g. high yeast content waste water, lactic and formic acids from degrading milk content;
- nature of raw water source, either hard or soft.

Waste water contains few compounds that individually have an adverse effect on a WWTP or a receiving water body. Possible exceptions include:

- salt where large amounts are used, e.g. pickling and cheesemaking;
- pesticide residues not readily degraded during treatment;
- residues and by-products from the use of chemical disinfection techniques;
- some cleaning products.

The presence of pathogenic organisms in the waste water may be an issue, particularly where meat or fish are being processed. The amount of plant nutrients may also be an issue. Excessive emission levels of phosphorus can also occur, particularly where large quantities of phosphoric acid are used in the process, e.g. vegetable oil de-gumming, or in cleaning. If such waste water becomes anaerobic during treatment then there is a risk that constituents containing phosphate could release phosphorus to the final discharge water. The use of nitric acid in the process produces a similar effect, thereby increasing the emission levels of nitrate in the waste water.

2.3 Techniques to consider in the determination of BAT across the FDM sector

This section describes techniques (or combinations thereof), and associated monitoring, considered to have the potential for achieving a high level of environmental protection in the activities within the scope of this document. The techniques described will include both the technology used and the way in which the installations are designed, built, maintained, operated and decommissioned.

It covers environmental management systems, process-integrated techniques and end-of-pipe measures. Waste prevention and management, including waste minimisation and recycling procedures are also considered, as well as techniques that reduce the consumption of raw materials, water and energy by optimising use and reuse. The techniques described also cover measures used to prevent or to limit the environmental consequences of accidents and incidents, as well as site remediation measures. They also cover measures taken to prevent or reduce emissions under other than normal operating conditions (such as start-up and shutdown operations, leaks, malfunctions, momentary stoppages and the definitive cessation of operations).

Annex III to the Directive lists a number of criteria for determining BAT, and the information within this chapter will address these considerations. As far as possible, the standard structure in Table 2.34 is used to outline the information on each technique, to enable a comparison of techniques and the assessment against the definition of BAT in the Directive.

This chapter does not necessarily provide an exhaustive list of techniques which could be applied in the sector. Other techniques may exist, or may be developed, which could be considered in the determination of BAT for an individual installation.

Table 2.34: Information for each technique

Headings within the sections
Description
Technical description
Achieved environmental benefits
Environmental performance and operational data
Cross-media effects
Technical considerations relevant to applicability
Economics
Driving force for implementation
Example plants
Reference literature

In this document, techniques have been included in this chapter, whether or not they are considered in the determination of BAT.

The techniques described show that prevention can be achieved in many ways, such as using production techniques that pollute less than others; reducing material inputs; re-engineering the processes to reuse products, which for example have not met the customer's specification; improving management practices and substituting substances with less hazardous ones. This chapter provides information on some general and specific pollution prevention and control techniques that have been implemented on an industrial scale.

The EFS BREF [167, COM 2006] covers general storage and handling techniques so these are generally not included in this document, unless they are related to FDM-specific issues such as food safety and shelf life.

The FDM sector is so diverse that it is impractical to describe every technique that can be considered in the determination of BAT for every activity and under every circumstance. It is, however, evident that there are various good techniques used in one part of the sector that are also applicable in others. Care has been taken to ensure that the techniques described do not conflict with other relevant legislation, e.g. on hygiene, food/feed safety or refrigerants.

2.3.1 General environmental performance

2.3.1.1 Environmental management systems

Description

A formal system to demonstrate compliance with environmental objectives.

Technical description

The Directive defines ‘techniques’ (under the definition of best available techniques) as ‘both the technology used and the way in which the installation is designed, built, maintained, operated and decommissioned’.

In this respect, an environmental management system (EMS) is a technique allowing operators of installations to address environmental issues in a systematic and demonstrable way. EMSs are most effective and efficient where they form an inherent part of the overall management and operation of an installation.

An EMS focuses the attention of the operator on the environmental performance of the installation; in particular through the application of clear operating procedures for both normal and other than normal operating conditions, and by setting out the associated lines of responsibility.

All effective EMSs incorporate the concept of continuous improvement, meaning that environmental management is an ongoing process, not a project which eventually comes to an end. There are various process designs, but most EMSs are based on the plan-do-check-act cycle (which is widely used in other company management contexts). The cycle is an iterative dynamic model, where the completion of one cycle flows into the beginning of the next (see Figure 2.6).

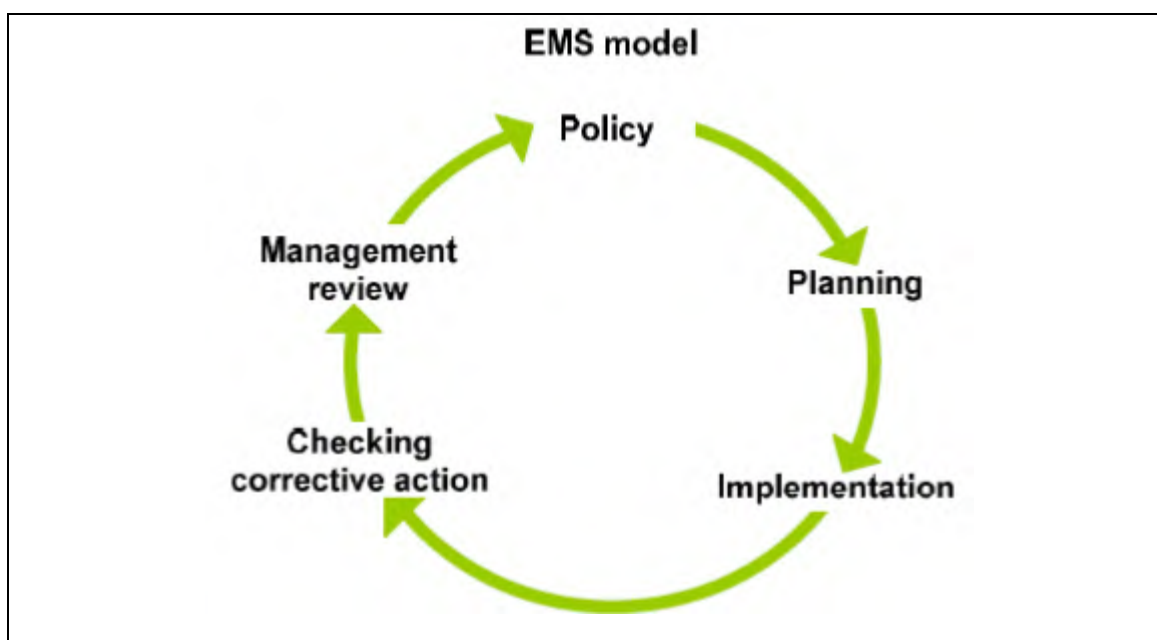

Figure 2.6: Continuous improvement in an EMS model

An EMS can take the form of a standardised or non-standardised (or customised) system. Implementation and adherence to an internationally accepted standardised system, such as EN ISO 14001:2015, can give higher credibility to the EMS especially when subjected to a properly performed external verification. The European Union eco-management and audit scheme (EMAS) according to Regulation (EC) No 1221/2009 provides additional credibility due to the interaction with the public through the environmental statement and the mechanism to ensure compliance with the applicable environmental legislation. However, non-standardised systems can, in principle, be equally effective provided that they are properly designed and implemented.

While both standardised systems (EN ISO 14001:2015 or EMAS) and non-standardised systems apply in principle to organisations, this document takes a narrower approach, not including all activities of an organisation, e.g. with regard to their products and services, due to the fact that the Directive only regulates installations.

An EMS can contain the following features:

- i. commitment, leadership, and accountability of the management, including senior management, for the implementation of an effective EMS;
- ii. an analysis that includes the determination of the organisation's context, the identification of the needs and expectations of interested parties, the identification of characteristics of the installation that are associated with possible risks for the environment (or human health) as well as of the applicable legal requirements relating to the environment;
- iii. development of an environmental policy that includes the continuous improvement of the environmental performance of the installation;
- iv. establishing objectives and performance indicators in relation to significant environmental aspects, including safeguarding compliance with applicable legal requirements;
- v. planning and implementing the necessary procedures and actions (including corrective and preventive actions where needed), to achieve the environmental objectives and avoid environmental risks;
- vi. determination of structures, roles and responsibilities in relation to environmental aspects and objectives and provision of the financial and human resources needed;

- vii. ensuring the necessary competence and awareness of staff whose work may affect the environmental performance of the installation (e.g. by providing information and training);
- viii. internal and external communication;
- ix. fostering employee involvement in good environmental management practices;
- x. Establishing and maintaining a management manual and written procedures to control activities with significant environmental impact as well as relevant records;
- xi. effective operational planning and process control;
- xii. implementation of appropriate maintenance programmes;
- xiii. emergency preparedness and response protocols, including the prevention and/or mitigation of the adverse (environmental) impacts of emergency situations;
- xiv. when (re)designing a (new) installation or a part thereof, consideration of its environmental impacts throughout its life, which includes construction, maintenance, operation and decommissioning;
- xv. implementation of a monitoring and measurement programme, if necessary, information can be found in the Reference Report on Monitoring of Emissions to Air and Water from IED Installations;
- xvi. application of sectoral benchmarking on a regular basis;
- xvii. periodic independent (as far as practicable) internal auditing and periodic independent external auditing in order to assess the environmental performance and to determine whether or not the EMS conforms to planned arrangements and has been properly implemented and maintained;
- xviii. evaluation of causes of nonconformities, implementation of corrective actions in response to nonconformities, review of the effectiveness of corrective actions, and determination of whether similar nonconformities exist or could potentially occur;
- xix. periodic review, by senior management, of the EMS and its continuing suitability, adequacy and effectiveness;
- xx. following and taking into account the development of cleaner techniques.

EMAS is an example of an EMS that includes the aforementioned features i. to xx.

Achieved environmental benefits

An EMS promotes and supports the continuous improvement of the environmental performance of the installation. If the installation already has a good overall environmental performance, an EMS helps the operator to maintain the high performance level.

Environmental performance and operational data

No information provided.

Cross-media effects

None reported. The systematic analysis of the initial environmental impacts and scope for improvements in the context of the EMS sets the basis for assessing the best solutions for all environmental media.

Technical considerations relevant to applicability

The components described above can typically be applied to all installations within the scope of this document. The level of detail and the degree of formalisation of the EMS will generally be related to the nature, scale and complexity of the installation, and the range of environmental impacts it may have.

Economics

It is difficult to determine accurately the costs and economic benefits of introducing and maintaining a good EMS. There are also economic benefits that are the result of using an EMS and these vary widely from sector to sector.

External costs relating to verification of the system can be estimated from guidance issued by the International Accreditation Forum [[171, IAF 2010](#)].

Driving force for implementation

The driving forces for the implementation of an EMS include:

- improved environmental performance;
- improved insight into the environmental aspects of the company which can be used to fulfil the environmental requirements of customers, regulatory authorities, banks, insurance companies or other stakeholders (e.g. people living or working in the vicinity of the installation);
- improved basis for decision-making;
- improved motivation of personnel (e.g. managers can have confidence that environmental impacts are controlled and employees can feel that they are working for an environmentally responsible company);
- additional opportunities for operational cost reduction and product quality improvement
- improved company image;
- reduced liability, insurance and non-compliance costs.

Example plants

EMSs are applied in a high number of installations throughout the EU. The FDM sector is one of the industrial sectors with the most EMAS-registered organisations [179, COM 2015].

Reference literature

[2, IED Forum 2018], [171, IAF 2010], [172, EC 2009], [173, DG Environment 2010], [179, COM 2015]

2.3.1.2 Integrated monitoring system

Description

Integrated monitoring system, formed by a large amount of measuring equipment and permitting the tracking of the energy, gas and water consumption from input to points of consumption.

Technical description

An integrated monitoring system is formed by a large amount of measuring equipment and it permits the tracking of the energy, gas and water consumption from input to points of consumption. The system can obtain data from measuring equipment, such as calorimeters, electric watt-hour meters, gas meters and CO₂ meters.

Monitoring of water and energy consumption could include direct measurements, calculation or recording, e.g. using suitable meters or invoices. The monitoring is broken down at the most appropriate level (e.g. at process or plant/installation level) and considers any significant changes in the plant/installation.

This technique could also include a system of hardware and software for the automatic detection of electric energy and water consumption. It allows the constant monitoring of installation energy consumption (process consumption and utilities such as air compressors, air treatment units, refrigeration unit and lighting), the detection of deviations and the estimation of the consumption reduction.

Achieved environmental benefits

Benefits include the control and measurement of water and energy consumption in an integrated way. This permits the main points of consumption and potential points of savings to be identified, consumption levels to be controlled, points of losses or incorrect functioning to be identified, and achieved savings to be measured.

Environmental performance and operational data

An example of monitoring is to control temperature, by dedicated measurement and correction.

Cross-media effects

No information provided.

Technical considerations relevant to applicability

The technique can be implemented in the overall operation of a FDM installation.

Economics

Investment and operating costs generally depend on the type of measurement and complexity of installation.

Driving force for implementation

The implementation of this technique is stimulated by the potential economic savings, rise in yield and efficiency, and improvement of operating conditions.

Example plants

A dairy installation (#189) [[193, TWG 2015](#)].

Reference literature

[[193, TWG 2015](#)]

2.3.1.3 Temperature control by dedicated measurement and correction

Description

Raw material waste and waste water generation can be reduced by controlling the temperature, e.g. in storage vessels, processing vessels and transfer lines.

Technical description

Raw material waste and waste water generation can be reduced by controlling the temperature, e.g. in storage vessels, processing vessels and transfer lines. Possible benefits from this include reduced deterioration of materials, reduced out-of-specification products and less biological contamination. The application of temperature sensors can sometimes be optimised by using them for dual purposes, e.g. for monitoring both product and cleaning temperatures.

Achieved environmental benefits

Reduced energy consumption and reduced waste generation. Potentially reduces water consumption, if water or steam are used for heating.

Environmental performance and operational data

It has been reported that in dairies the temperature of the milk can be maintained during heat treatment by controlling the flow of steam or hot water.

In confectionery manufacture, temperature sensors can be used to minimise the temperature drop during product transfer, thereby minimising product deterioration.

In meat processing, the temperature of thawing baths for frozen meat can be maintained by controlling the water flow.

In an example meat processing company, installing thermocouples to provide temperature control allowed it to reduce its water supply costs by up to 10 %. Thermocouples on the water inlet and outlet to a chilling and washing system feed into an automated control valve which optimises the flow rate. The control system has reduced water use, energy use and waste water generation significantly, while maintaining a sufficient flow rate to meet the process's hygiene requirements.

A company fermenting molasses to produce alcohol installed an improved temperature control in a fermentation vessel, which was regularly exceeding the required temperature by 5 °C. The result was increased production yields and a 15 % reduction in waste.

Cross-media effects

No information provided.

Technical considerations relevant to applicability

Applicable in installations where heat processes are applied and/or materials are stored or transferred at critical temperatures or within critical temperature ranges.

Economics

In the example where thermocouples were used, the company reported savings of GBP 13 000/year for an initial investment of GBP 3 000, giving a payback period of 12 weeks (2000). Savings can be achieved due to increased production yields and reduced waste generation.

Driving force for implementation

Minimisation of product deterioration, increased production yields and reduced water consumption.

Example plants

Applied in dairies, confectionery manufacture, at least one meat processing installation in the UK and at least one molasses fermentation installation in the UK.

Reference literature

[10, Envirowise (UK) & Entec UK Ltd 1999]

2.3.1.4 Level measurement

Description

Application of level-detecting sensors and level-measurement sensors.

Technical description

The two main categories of level sensors are level-detecting sensors and level-measurement sensors. Level-detecting sensors indicate whether or not a fluid is present at a specific point in a vessel (usually a high or low point). Most applications are connected to a visual indicator, a visual or audible alarm, or on-off control of flows in or out of the vessel. Level-measurement sensors allow continuous monitoring of actual fluid levels, with associated variable controls, e.g. increasing or slowing pumping rates.

Achieved environmental benefits

Reduced consumption of cleaning materials and water; reduced generation of waste water and reduced risk of contamination of soil, surface and groundwater.

Environmental performance and operational data

At an example brewery, a capacitance level switch is used to detect the interface between yeast and beer. The beer was then run off to storage. Yeast can be recovered and used as animal feed.

In beer making, every 1 % of wort going to drain adds about 5 % to the waste water COD; this can be avoided by using level sensors to prevent overfilling of process vessels with very high COD emission levels.

An example large vegetable processing company made savings through reduced water costs, waste water charges and operator time by installing level controls on the water supply tanks to the flume system that transported the vegetables. Previously, an operator adjusted the water

supply controls manually, which led to excessive water overflow from the tanks when the operator was occupied elsewhere. A simple float valve was identified as offering a low-cost solution. The valve now controls the water flow to the tanks, freeing the operator to work elsewhere.

Cross-media effects

There are no cross-media effects associated with this technique.

Technical considerations relevant to applicability

Widely applicable in the FDM sector, e.g. where liquids are stored or reacted in tanks or vessels, either during manufacturing or cleaning processes. Table 2.35 shows some examples of how level sensors can be used to reduce material waste and waste water generation.

Table 2.35: Examples of use of level sensors in FDM processing

Installation	Reason for control
Storage or reaction tanks	Prevent overflow and waste of material or water
Storage vessels	Provide information for stock control. Minimise waste from out-of-date stock or production losses due to material not being available
Vessels with automatic transfer controls	Minimise waste from transfer losses or inaccurate batch recipes
Liquid food materials	To monitor the level in storage tanks to avoid overfilling and loss to drain
CIP/disinfection-in-place	As a level switch in vessel cleaning to optimise the amount of water/detergent used and to protect against overspill

Source: [192, COM 2006]

Economics

In the example brewery, the process modifications cost GBP 9 500 (1999), but the associated reduction in beer losses and waste water charges worth GBP 800 000/year meant the payback period was 5 days.

The example vegetable processing company saved over GBP 15 000/year through reduced water costs, waste water charges and operator time. The payback period was a few months.

Driving force for implementation

Expensive loss of product.

Example plants

Widely applicable in the FDM sector.

Reference literature

[1, CIAA 2002], [7, Environment Agency of England and Wales 2000], [8, Environment Agency of England and Wales 2000], [10, Envirowise (UK) & Entec UK Ltd 1999], [192, COM 2006]

2.3.1.5 Conductivity measurement

Description

Measurement of the conductivity of water.

Technical description

Conductivity measurements are used to determine the purity of water or the concentration of acid or alkali, i.e. by determining the sum of the ionic components of the water. Electrode cells and inductive sensors are two types of sensors used to measure conductivity.

Electrode cells are contact-type sensors, which operate by passing the process fluid between two electrode plates. They are reported to be very accurate. Applications include monitoring process water for reuse, thereby minimising waste water generation and monitoring boiler water to minimise the build-up of deposits on hot surfaces.

Conductivity can also be measured using inductive sensors. These non-contact sensors use two electromagnetic coils around the process fluid and are suitable for hygienic applications. Inductive sensors have a greater range than electrode cells.

The conductivity of rinsing water from CIP (see Section 2.3.3.2.4) is used to determine when flushing is sufficient and CIP can be stopped (instead of using a timer). Rinsing water is collected for reuse to pre-rinse in CIP. By measuring the conductivity of rinsing water, CIP is stopped at the exact moment when flushing is sufficient. This causes consumption of water for rinsing to be reduced.

Achieved environmental benefits

Reduced water and detergent use and reduced quantities of waste water.

Environmental performance and operational data

Although fluid flow is not essential, it provides a self-cleaning effect. Air pockets should be avoided. The equipment should be able to compensate for the change in the conductivity of a fluid with temperature.

At an example dairy (Example A), the CIP cycle comprises a water flush to rinse out residual product; cleaning using acid or caustic detergent for a set period, followed by a water rinse. These stages were previously controlled by individual timers to limit the amount of detergent used. A number of lines and vessels are cleaned by each CIP unit, so the cleaning cycles vary. The timing of the opening and closing of the drain valve was, therefore, a compromise. This resulted in significant quantities of detergent being discharged as waste water.

Conductivity measurements were introduced to control the addition of acid or caustic cleaning solutions and to determine whether the cleaning solution(s) and/or water could be recovered. This indicated when detergent and/or water could be recovered, and whether the right amount of detergent was being used. All existing CIP units were retrofitted with conductivity probes and they were included in the specification for all new units.

The system works by placing a conductivity probe in the main pipeline from the process equipment, close to the detergent tank inlet. The probe monitors the detergent/water concentration flowing through the line during a cleaning cycle. Detergent cleaning is initiated by a timer and detergent gradually replaces the flush water in the system, which is drained for waste water treatment. Once a set detergent concentration is detected, the conductivity probe signals an actuator to close the drain valve. The flow is then diverted back to the detergent tank and circulated through the system, rather than being discharged. The rinse stage is then initiated by a timer; detergent is recycled back to the detergent tank until dilution has occurred and the set detergent concentration is reached again. At this point, a signal from the conductivity probe opens the drain valve and the rinse water is drained for waste water treatment until the probe detects clean water again.

The drain valve is then closed and the clean water is diverted to the water tank. The conductivity probe also ensures that the required detergent strength is maintained throughout the cleaning process. Minimal operator attention is required. Each conductivity probe receives some cleaning when the process equipment is cleaned in place. Daily detergent use is monitored by a flow meter on every CIP unit. If detergent use increases, this indicates that the probe requires further cleaning, i.e. a 10-minute task done by the operators. Additional probe cleaning is usually required every 4 to 6 weeks.

The dairy reports an estimated 15 % saving on detergent for each CIP unit; reduced amounts of water and detergent discharged for waste water treatment; reduced downtime of equipment and optimised quantity of detergent used for each cleaning cycle.

In another dairy (Example B), conductivity meters were installed to help reduce detergent use. The conductivity probe detects whether water or detergent is in the line and, if detergent is present, it diverts the flow to a detergent recovery tank. The result was recycling of rinse water, reduced use of detergent and a consequent reduction in COD in the waste water.

Cross-media effects

There are no cross-media effects associated with this technique.

Technical considerations relevant to applicability

Widely applicable in the FDM sector in processing and cleaning applications. Examples of the use of conductivity measurement in the FDM sector are shown in Table 2.36. Typical applications of conductivity measurement in the FDM sector are shown in Table 2.37.

Table 2.36: Examples of the use of conductivity measurement in the FDM sector

Activity	Reason for control
Monitor levels of dissolved salts prior to water reuse	Minimise fresh water use and waste water generation
Monitor well water	Minimise production of poor quality product (that becomes waste) due to use of unsuitable process water

Source: [192, COM 2006]

Table 2.37: Typical applications of conductivity measurement in the FDM sector

Sector/activity	Application
CIP	Conductivity monitoring for installation valve control, based on differences between product, e.g. between beer and water or caustic and acid
Bottling (general)	Conductivity monitoring of caustic use in bottle-cleaning solutions
Product monitoring (inductive sensors)	Throughout the drinks industries and in dairies

Source: [192, COM 2006]

Economics

The saving on detergent by the Example A dairy is reported as GBP 13 000/year. The company reports a payback period of 16 months.

The Example B dairy reported savings of GBP 10 000/year and a payback period of 4 months on the investment.

Driving force for implementation

Reduced detergent use.

Example plants

Numerous installations in the drinks and dairy industries and where CIP is used.

Reference literature

[7, Environment Agency of England and Wales 2000], [10, Envirowise (UK) & Entec UK Ltd 1999], [192, COM 2006], [193, TWG 2015]

2.3.1.6 Turbidity measurement

Description

Measurement of the turbidity of water.

Technical description

Scattered light turbidity devices use a light diffusion method to measure the light scattered through a right angle by the particles or bubbles in the liquid. This method is used for low to average turbidity measurements, including the measurement of turbidity in distilled water. Sampling devices can be used when it is difficult to install the turbidity meter into a process line. This helps to improve hygiene.

Suspended solids turbidity meters work using a light absorption method that measures the amount of light transmitted through matter in the process fluid. They are used for measuring medium to high levels of turbidity.

Achieved environmental benefits

Reduced material loss during processing, increased reuse of water and reduced waste water generation.

Environmental performance and operational data

Turbidity meters should preferably be installed in vertical pipes with an upward flow and the optical unit facing the direction of flow for maximum self-cleaning. To avoid incorrect measurements from floating or settled debris, horizontal pipes should have meters installed at the side and not at the bottom or top, to avoid fouling by deposition and floating debris respectively. The fluid velocity should not exceed 2 m/s to avoid spurious readings. To minimise deflection of the beam, gas bubbles and degassing should be avoided.

In a reported food manufacturing process, some product was lost down the drain during the separation stages, which resulted in a breach of the company's water discharge consent. The installation of a hygienic turbidity meter and a flow meter resulted in reduced product losses to drain, increased product yield and financial savings.

Cross-media effects

Energy consumption associated with the turbidity meter.

Technical considerations relevant to applicability

Applicable where product yield can be increased by recovery from process water and for the reuse of cleaning water.

Examples of the use of turbidity measurement in the FDM sector are shown in Table 2.38.

Table 2.38: Examples of the use of turbidity measurement in the FDM sector

Activity	Reason for control
Monitor quality of process water	Minimise waste water from out-of-specification process water or products
Monitor CIP systems	Optimise reuse of cleaning water, thus minimising waste water generation
<i>Source:</i> [192, COM 2006]	

A typical application of turbidity measurement in the FDM sector is the monitoring of process waste streams to determine viability for recovery back into the process.

Economics

Reported lower waste water treatment costs and savings of over GBP 100 000/year and reported cost savings of around GBP 16 000/year and a payback period of 8 months on combined capital and installation costs.

Driving force for implementation

- Reduced product loss.
- To lower the COD level in the waste water and especially the fat content which may cause problems in the waste water pipes.

Example plants

At least one cheesemaking dairy and another unspecified food manufacturing installation in the UK.

Reference literature

[7, Environment Agency of England and Wales 2000], [10, Envirowise (UK) & Entec UK Ltd 1999], [192, COM 2006], [193, TWG 2015]

2.3.1.7 Consumption and stream inventory/register

Description

The compilation of relevant basic data on water, energy and raw materials consumption as well as on the composition and quantity of waste water and waste gas streams – each one individually – is done in a consumption and stream inventory/register. The consumption and emitted streams are listed respective to their source, i.e. the process from which they originate. This is a key element in assessing the resource efficiency of the installation, the nature of the contaminants as well as the possibilities of reduction at the source.

Technical description

A consumption and stream inventory/register addresses the following aspects, if relevant to the particular local conditions:

- (i) Information about the food, drink and milk production processes, including:
 - (a) simplified process flow sheets that show the origin of the emissions;
 - (b) descriptions of process-integrated techniques and waste water/waste gas treatment techniques to prevent or reduce emissions, including their performance.
- (ii) Information about water consumption and usage (e.g. flow diagrams and water mass balances), and identification of actions to reduce water consumption and waste water volume.
- (iii) Information about the quantity and characteristics of the waste water streams, such as:
 - (a) average values and variability of flow, pH, temperature;
 - (b) average concentration and load values of relevant pollutants/parameters and their variability (e.g. COD/TOC, nitrogen species, phosphorus, conductivity).
- (iv) Information about the characteristics of the waste gas streams, such as:
 - (a) average values and variability of flow and temperature;
 - (b) average concentration and load values of relevant pollutants/parameters and their variability (e.g. dust, TVOC, CO, NO_x, SO_x) and their variability;
 - (c) presence of other substances that may affect the waste gas treatment system or plant safety (e.g. oxygen, water vapour, dust).
- (v) Information about energy consumption and usage, the quantity of raw materials used, as well as the quantity and characteristics of residues generated, and identification of actions for continuous improvement of resource efficiency.
- (vi) Identification and implementation of an appropriate monitoring strategy with the aim of increasing resource efficiency, taking into account energy, water and raw materials consumption. Monitoring can include direct measurements, calculations or recording with an appropriate frequency. The monitoring is broken down at the most appropriate level (e.g. at process or plant/installation level).

Achieved environmental benefits

The reduction of emissions to water and/or air. Identification of relevant waste water/waste gas streams is a prerequisite for an efficient waste water/waste gas management and for the reduction of emissions by technical and management measures.

Environmental performance and operational data

No information provided.

Cross-media effects

None.

Technical considerations related to applicability

The scope (e.g. level of detail) and nature of the inventory will generally be related to the nature, scale and complexity of the installation, and the range of environmental impacts it may have.

Economics

No information provided.

Driving force for implementation

Inventories/registers may be used to assess the implementation of BAT and may constitute basic information for authorities in order to set emission limit values.

Example plants

Stream inventory is applied in a number of installations throughout the EU.

Reference literature

[168, COM 2016]

2.3.2 Techniques to increase energy efficiency**2.3.2.1 General processing techniques****2.3.2.1.1 Heat recovery****Description**

Use of heat exchangers and heat pumps to recover heat.

Technical description

The FDM sector has plenty of examples of heat recovery. The most commonly used heat recovery methods are the following:

- direct usage: heat exchangers make use of heat as it is in the surplus stream;
- heat pumps upgrade the heat in relatively cold streams so that it can perform more useful work than could be achieved at its present temperature (i.e. an input of high-quality energy raises the energy quality of the waste/surplus heat).

Heat can be also recovered from the blowdown of a boiler.

Another example of heat recovery is related to air compressors. From 80 % to 90 % of the mechanical energy that is consumed by compressors in an air-compressed system is converted to thermal energy. This causes an increase in air temperature and for this reason a compressor cooling system is required. In this way, this heat can be recovered and reused. The heat output from air compressors can be crossed with water or air to transfer the heat and, then, the heat can be reused. Heating systems, the drying processes and heat feed to the steam boiler or oven burners are the main applications of the heated airstream. The applications of heated water streams are varied [193, TWG 2015].

Achieved environmental benefits

Reduction of energy consumption.

Environmental performance and operational data

There are multiple ways of reusing water reported in the questionnaires of the FDM BREF data collection [193, TWG 2015]. Some examples are presented in Table 2.39.

Table 2.39: Various examples of heat recovery in the FDM sector

Heat recovery technique	Technical description	Example installations	Economics
Breweries			
Heat recovery from wort boiling	The simplest way to recover heat from the vapour is to use it to produce hot water for various processes, e.g. for use in production, cleaning operations, flushing brew kettles or for room heating.	#157, #159	EUR 1 600 000 as installation cost and EUR 30 000 as annual operating cost (maintenance cost), for a reduction of 4 kWh/hl of heat consumption
Dairies			
Heat recovery from the refrigeration plant to pasteurisation	An ammonia-based heat pump is incorporated to use waste heat from the refrigeration cycle to boost pasteurising temperatures.	At least one dairy installation in UK	High investment and operating costs, with a payback period of around 8 years
Heat recovery from pasteurisation in ice cream production	The heat released to the water from the ice cream mix can preheat the water for various purposes, mainly for cleaning operations.	At least one ice cream installation in SE	NI
Heat recovery from warm whey	Utilisation of heat from warm whey for preheating cheese milk	Dairies in DK and in UK (#408)	Investment cost of about EUR 500 000 and annual operating cost of about EUR 20 000
Oilseed processing and vegetable oil refining			
Heat recovery from the hardening of vegetable oils	The hydrogenation reaction that occurs during the hardening of oils to produce fats for cooking, eating and soap-making is an exothermic process. The heat can be used to heat the product to the desired reaction temperature and to generate steam later in the reaction.	Widely applied in the OI sector	Additional investment costs are needed. Lower operational costs due to the reduced input of steam generation.
Heat recovery from the rapeseed dryer	The exhausted vapours from the rotary dryer in the rapeseed processing installation are used to heat water for preheating the seeds and reaching an optimum heat recovery.	#86, #466	Investment cost: approximately EUR 100 000 for a heat exchanger with operational air flow rate of 20 000 Bm ³ . Operating cost: approximately EUR 3 900 annually (electricity for circulation pump).
Starch production			
Preheating of potato fruit juice	Preheating of potato fruit juice to about 100 °C is performed by reusing hot fruit juice, from where protein already has been extracted.	#149, #150, #151, #152	An investment cost of EUR 1 300 000 (capacity about 100 m ³ /h in terms of fruit juice) and annual savings of EUR 200 000 (reduction of natural gas consumption) have been reported.
NB: ; NI= no information provided. Source: [108, NEWPOTATOPRO LIFE project 2007], [192, COM 2006], [193, TWG 2015], [227, United Kingdom 2015]			

Cross-media effects

No information provided.

Technical considerations relevant to applicability

Heat recovery opportunities are present in existing and new FDM installations. As indicated in the ENE BREF [132, COM 2009], heat recovery is not applicable where there is no demand that matches the production curve.

Economics

See Table 2.39.

Driving force for implementation

In line with the EU Action Plan for the Circular Economy [180, COM 2015], heat recovery aims to improve the resource efficiency of the FDM sector.

Example plants

Heat recovery is commonly reported in all FDM sectors [193, TWG 2015].

Reference literature

[108, NEWPOTATOPRO LIFE project 2007], [132, COM 2009], [180, COM 2015], [192, COM 2006], [193, TWG 2015], [227, United Kingdom 2015]

2.3.2.1.2 Use of the biogas generated**Description**

The biogas generated by anaerobic digestion or anaerobic treatment of waste water is used as a fuel, e.g. in a gas engine or in a boiler. It may be previously treated (e.g. to remove hydrogen sulphide).

Technical description

The biogas (methane) produced by the anaerobic digester or by anaerobic waste water treatment passes through a scrubber (sodium hydroxide to remove hydrogen sulphide) and then flows through a series of condensate traps before entering a biogas holder. The methane stored in the biogas holder is preconditioned (dried) and then passes through a gas analyser and then on to the gas engine. The gas is combusted in a gas engine which powers a generator producing electricity. Heat is recovered from cooling water and the exhaust is used to heat boiler feed water for example.

Alternatively, the biogas can also be used directly, e.g. in a boiler producing process heat or a DDGS dryer, without treatment. In the big installations the steam from the boilers is usually used in combined production of power and process heat (e.g. sugar industry).

CHP plants are most suited to sites where the feed source is readily available and ideally generated at the site as either a waste or by-product such as FDM installations with large amounts of organic wastes which are treated by anaerobic digestion. For general information about CHP see Section 2.1.2.1.1.

Achieved environmental benefits

The CHP plant enables the methane gas generated by the anaerobic digester to be converted to a valuable renewable source of energy. Additionally, the CHP plant enables the anaerobic digester to divert waste and instead convert it to a valuable product.

Environmental performance and operational data

In a dairy installation (#296), the electricity produced from the generator is converted from low to medium voltage (400 V – 10 000 V) and directed to the main switch room for use on site.

A dryer and recuperator were installed on the gas supply line to the CHP. This was necessary to maintain the gas quality, thereby preventing damage to the CHP engine resulting from condensation and other gases. The engine is sensitive to hydrogen sulphide gas and therefore a scrubber system is provided upstream to remove this compound.

Cross-media effects

Emissions to air are generated from the combustion.

Technical considerations relevant to applicability

Generally applicable.

Economics

A total cost of around EUR 1 million has been reported (for a CHP plant that generates 600 kWh of electrical and 600 kWh of thermal energy) [193, TWG 2015].

Driving force for implementation

- Reduction of fuel consumption.
- Generation and utilisation of a renewable source of energy and conversion of waste product into a valuable asset.

Example plants

Installation #296 uses biogas generated from an anaerobic digester. Installation #287 uses the generated biogas directly in a DDGS dryer.

Reference literature

[193, TWG 2015]

2.3.2.1.3 Process control systems

Description

Automation of a facility to switch off equipment when it is not needed.

Technical description

Automation of a manufacturing facility involves the design and construction of a process control system, requiring sensors, instruments, computers and the application of data processing. It is widely recognised that automation of manufacturing processes is important not only to improve product quality and workplace safety, but also to increase the efficiency of the process itself and contribute to energy efficiency. More information on process control systems can be found in the ENE BREF [132, COM 2009].

Many measures can be taken through process control systems, such as switching off equipment, such as compressors and lighting. Pumps and fans that circulate cold air, chilled water or an antifreeze solution generate heat, contributing most of the power they consume to the cooling load, so switching them off when not required saves energy. This is also true for lights in a coldstore or cooled room, as they contribute most of the power they consume to the cooling load.

The switching can be timed according to a fixed programme or schedule. Conditions can be monitored to detect high or low temperatures for example and switch off motors when they are not needed. The load of a motor can be sensed, so that the motor is switched off when idling.

Achieved environmental benefits

Reduced energy consumption.

Environmental performance and operational data

See process control systems in the ENE BREF [132, COM 2009].

Cross-media effects

See process control systems in the ENE BREF [132, COM 2009].

Technical considerations relevant to applicability

Widely applicable in the FDM sector.

Economics

See process control systems in the ENE BREF [132, COM 2009].

Driving force for implementation

Reduced energy costs.

Example plants

This technique is commonly reported in all FDM sectors [193, TWG 2015].

Reference literature

[39, Environment Agency of England and Wales 2001],[132, COM 2009],[193, TWG 2015]

2.3.2.1.4 Combined heat and power generation**Description**

Use of a heat engine or power station to generate electricity and useful heat at the same time.

Technical description

Information on different cogeneration applications can be found in the ENE BREF [132, COM 2009].

Achieved environmental benefits

Reduced energy consumption and emissions to air, e.g. NO_x, CO₂ and SO₂.

Environmental performance and operational data

The energy efficiency of CHP can be as high as 90 %. This optimises the use of fossil fuels and reduces the production of CO₂. New CHP installations save at least 10 % of the fuel otherwise used in the separate production of heat and electricity. Furthermore, gas-fired CHP schemes can eliminate SO₂ emissions and NO_x can be controlled to meet environmental legislation. Modern CHP equipment is likely to require less effort to operate and maintain than many older boiler systems, as it is equipped with automatic control and monitoring systems.

It is reported that most of the energy required in sugar manufacturing is obtained by burning gas, heavy fuel oil or coal in a boiler house, which converts it, by means of CHP equipment, into steam and electricity. In this sector, the overall fuel utilisation factor of CHP exceeds 70 % and is typically above 80 %. This fuel conversion efficiency greatly exceeds that of any design of commercial power stations whose steam is not used further, including even the latest generation of combined cycle gas turbines, which are around 55 % efficient. Excess electricity produced may be sold to other users [192, COM 2006].

Cross-media effects

See cogeneration in the ENE BREF [132, COM 2009].

Technical considerations relevant to applicability

Widely applicable. The applicability of CHP very much depends on several technical aspects. Although CHP is a well-established and technically mature technique, it is vital that the right design decisions are made. The main factors to consider are the consumption pattern of electricity and heat in the installation and the ratio between electricity and heat consumption.

Additional important factors are whether the installation is running continuously and whether large variations in processes occur. A simple rule of thumb is that the site needs to have a simultaneous demand for heat and electricity for at least 4 000 hours a year.

Economics

A decision on whether to implement CHP based on investigation of the economic aspects will take account of the price of gas and electricity. A balance of relatively expensive gas or other fuels and cheap electricity mitigates against the selection of CHP. For example, if electricity prices fall or gas prices rise, the financial return from CHP will decrease. This is possible in a free energy market. One option, which is sometimes applied, is to design the CHP installation on the basis of heat consumption with excess electricity being sold to the public grid. Whether this is an attractive option very much depends on the price obtained for the excess electricity that is sold.

With regard to financing of the CHP installation, the tendency is for companies to not finance it themselves. Sometimes joint ventures with energy suppliers are formed and sometimes third parties completely finance the CHP installation. A contract for delivery of electricity and heat by the CHP installation normally runs for 10 to 15 years.

In the UK, it has been found that CHP can now reduce the total energy bills of an installation by 20 %. In the example brewery, the savings in energy costs were 16.2 %.

Example plants

Applied in sugar manufacturing installations, dairies, breweries and distilleries.

Driving force for implementation

The introduction of measures and procedures to promote cogeneration installations is supported by Directive 2012/27/EU of the European Parliament and of the Council of 25 October 2012 on energy efficiency.

Reference literature

[53, COM 2002], [132, COM 2009], [192, COM 2006]

2.3.2.1.5 Insulation of pipes, vessels and equipment

Description

Insulation of pipes, vessels and equipment by selecting effective coating materials.

Technical description

Insulation of pipes, vessels and equipment such as ovens and freezers can minimise energy consumption. Insulation can be optimised by selecting effective coating materials with low conductivity values and high thickness and by using pipes, vessels and equipment that are insulated prior to installation. Pre-insulation has the advantage that the pipe supports are mounted outside of the insulation coating instead of being directly connected for example. This reduces the heat loss through the mounts.

Insufficient insulation of pipework can lead to excessive heating of the surrounding process areas as well as the risk of burn injuries.

Achieved environmental benefits

Reduced energy consumption and associated fuel consumption and emissions to air.

Environmental performance and operational data

Insulation of pipes and tanks can reduce the heat/cold loss by 82–86 %. Additionally, 25–30 % heat can be saved by using pre-insulated pipes instead of traditionally insulated ones.

Hot and cold products are stored and pumped in dairies. In a new example dairy in Denmark, all of the pipes with a temperature difference of at least 10 °C above ambient temperature were fitted with 30 mm insulation. Tanks were coated with 50 mm insulation. Pre-insulated pipes with a coating of mineral wool wrapped in a metal sheet. More than 9 km of pipework and 53 tanks were insulated. The calculated savings in energy were 6 361 MWh/year heating energy and 2 397 MWh/year cold energy, i.e. the equivalent of 479 MWh/year electricity.

In an example Italian pasta installation, the energy dissipated all along pipework was investigated and the insulation was improved. In three cases, the thermal resistance was increased from 0.22 m².°C/W to 0.396 m².°C/W, 0.574 m².°C/W and 0.753 m².°C/W. This resulted in CO₂ emission reductions of 44.4 %, 61.6 % and 70.7 %, respectively.

Cross-media effects

No information provided.

Technical considerations relevant to applicability

Applicable to all FDM installations, whether new or existing. Pre-insulated pipes are applicable in new installations and where pipework, vessels and equipment are replaced.

Economics

In the example new Danish dairy, the investment cost was about EUR 1 408 000 with a payback period of 7.6 years.

Driving force for implementation

Reduction in energy costs.

Example plants

Widely applied in the FDM sector and others [193, TWG 2015].

Reference literature

[21, Nordic Council of Ministers 2001], [193, TWG 2015]

2.3.2.1.6 Frequency converters on motors

Description

Frequency converters (or variable speed drivers) regulate the speed of the impeller to the required output of the motor.

Technical description

Controlling the speed of the pump motor by frequency converters ensures that the speed of the impeller is exactly adapted to the required output of the pump, as are the power consumption and treatment of the liquid. More information on frequency converters (or variable speed drivers) can be found in the ENE BREF [132, COM 2009].

Achieved environmental benefits

Reduced energy consumption.

Environmental performance and operational data

The reduction of the power consumption depends on the capacity and number of pumps and motors. Generally, a 10 % reduction in the output of a pump corresponds to a 28 % reduction in the power consumption of the pump.

In an example German instant coffee manufacturer, the consistent implementation of frequency converters for all large electrical motors allowed them to be adjusted in a way that suited the output and electricity peaks during start-up processes were avoided.

In a Danish dairy, 203 motors were equipped with frequency converters. The total power of the motors was 1 216 kW. The estimated cost of the investment was EUR 311 000. The estimated annual saving is EUR 90 000 (1 325 000 kWh).

A whey products company processes whey into several raw materials for use in pharmaceuticals and foods. One of the products is lactose, the production of which involves a refining process, in which 'wet' lactose (9 % pure) is dissolved in hot water in a circular process. Wet lactose is transported through a shaking tray to a mixing vessel, where it is mixed with hot water. The mixture is pumped into a buffer vessel, where it is stirred, and from which it is returned to the mixing vessel. Thus, the lactose content of the mixture gradually increases. After approximately 1 hour, the mixture is discharged from the mixing unit for further processing. The liquid level in the mixing vessel used to be controlled by regulating the water/lactose flow from the buffer tanks. This was achieved by a choke valve on the delivery side of the centrifugal pump used for the transport. This choke system had several disadvantages, e.g. it was inefficient, causing unnecessary dissipation of electric energy, and it caused unnecessary wear of the pump. The system was replaced with a speed control system on the motor driving the pump. This resulted in energy savings amounting to 12 600 kWh/year, with a value of NLG 1 638 (1994), a reduction in maintenance costs of NLG 10 257/year (1994) and a payback period of 0.3 years.

In an example brewery, compressed air (6 bar) is produced by six screw-type and seven piston compressors. One screw-type compressor is run as a frequency-controlled machine and all compressors are centrally controlled. The advantage of this technology is that the pressure in the supply system does not fluctuate by more than +/- 0.05 bar. The system pressure can be reduced by 0.2 bar. It is reported that an electricity saving of approximately 20 % can be achieved by avoiding compressor idle time. Maintenance costs can be reduced by about 15 %. It is not possible to quantify the cost benefit resulting from the reduction in system pressure.

Cross-media effects

See variable speed drivers in the ENE BREF [[132, COM 2009](#)].

Technical considerations relevant to applicability

Frequency converters can be used with standard three-phase motors. They are available for both manual and automatic speed controls. They can be applied in existing and new installations for pumps, ventilation equipment and conveying systems. It is reported that frequency-converter-driven motors should not exceed 60 % of the total energy use of the installation because they can have an adverse effect on the electricity supply and can lead to technical problems.

Economics

The price of a 5.5 kW frequency converter is about EUR 600.

Driving force for implementation

Reduced consumption of electrical power in combination with a more gentle treatment of the product.

Example plants

This technique is commonly reported in all FDM sectors [[193, TWG 2015](#)].

Reference literature

[[19, German Dairy Association 2001](#)], [[21, Nordic Council of Ministers 2001](#)], [[35, Germany 2002](#)], [[132, COM 2009](#)], [[143, Caddet 1999](#)], [[193, TWG 2015](#)]

2.3.2.1.7 Energy-efficient lighting

Description

Measures such as energy-efficient lamps, use of natural light, or automatic light control.

Technical description

More energy-efficient lighting can be attained by [\[91, Giner Santonja et al. 2017 \]](#):

- i. replacing conventional tungsten light bulbs or other low-efficiency light bulbs with more energy-efficient lights such as fluorescent, sodium, and LED lights;
- ii. using devices to adjust the frequency of micro flashes, dimmers to adjust artificial lighting, sensors or room-entry switches to control the lighting;
- iii. allowing more natural light to enter, e.g. by using vents or roof windows; natural light has to be balanced with potential heat losses.

More information on energy-efficient lighting can be found in the ENE BREF [\[132, COM 2009 \]](#).

Achieved environmental benefits

Reduced energy consumption.

Environmental performance and operational data

See energy energy-efficient lighting in the ENE BREF [\[132, COM 2009 \]](#).

Cross-media effects

See energy energy-efficient lighting in the ENE BREF [\[132, COM 2009 \]](#).

Technical considerations relevant to applicability

See energy energy-efficient lighting in the ENE BREF [\[132, COM 2009 \]](#).

Economics

In a dairy installation, two 58 W neon tubes were replaced with two 22 W LED in 72 existing lamps. The investment cost was EUR 5 688. This led to energy savings of around 10 000 kWh/year [\[193, TWG 2015 \]](#).

Driving force for implementation

Reduced economic costs.

Example plants

This technique is commonly reported in all FDM sectors [\[193, TWG 2015 \]](#).

Reference literature

[\[91, Giner Santonja et al. 2017 \]](#), [\[132, COM 2009 \]](#), [\[193, TWG 2015 \]](#)

2.3.2.1.8 Energy efficiency plan

Description

An energy efficiency plan entails defining and calculating the specific energy consumption of the activity (or activities), setting key performance indicators on an annual basis (for example for the specific energy consumption) and planning periodic improvement targets and related actions. The plan is adapted to the specificities of the installation.

Technical description

Management to achieve energy efficiency requires structured attention to energy with the objective of continuously reducing energy consumption and improving efficiency in production and utilities, and sustaining the achieved improvements at both company and site level. It provides a structure and a basis for the determination of the energy efficiency, defining

possibilities for improvement and ensuring continuous improvement. All effective energy efficiency (and environmental) management standards, programmes and guides contain the notion of continuous improvement, meaning that energy management is a process, not a project which eventually comes to an end.

There are various process designs, but most management systems are based on the plan-do-check-act approach (which is widely used in other company management contexts). ISO 50001 is one of the more globally widespread standards for energy efficiency management systems.

More information on energy efficiency management systems can be found in the ENE BREF [132, COM 2009].

Achieved environmental benefits

See energy efficiency management systems in the ENE BREF [132, COM 2009].

Environmental performance and operational data

No information provided.

Cross-media effects

See energy efficiency management systems in the ENE BREF [132, COM 2009].

Technical considerations relevant to applicability

See energy efficiency management systems in the ENE BREF [132, COM 2009].

Economics

The cost of implementation of an energy management system, certified according to International Standard ISO 50001, in an existing grain milling installation with a permitted production capacity of around 500 tonnes/day is EUR 4 000 [193, TWG 2015].

Driving force for implementation

The implementation of the energy management system allows the energy consumption of the installation to be monitored.

Example plants

This technique is commonly reported in many of the FDM sectors [193, TWG 2015].

Reference literature

[132, COM 2009], [193, TWG 2015]

2.3.2.1.9 High-efficiency motors

Description

Use of high-efficiency motors to minimise motor losses.

Technical description

Motor losses can be minimised by specifying higher-efficiency motors where feasible. More information on energy-efficient motors can be found in the ENE BREF [132, COM 2009]. Other ways to minimise motor losses are:

- when a motor fails, ensuring that proper care and attention is given in the repair process so as to minimise energy losses;
- avoiding the use of greatly oversized motors;
- considering permanent reconnection of the motor electrical supply in star-phase, as a no-cost way of reducing losses from lightly loaded motors;
- checking that voltage imbalance, low or high supply voltages, harmonic distortion or a poor power factor is not causing excessive losses.

Achieved environmental benefits

Reduced energy consumption.

Environmental performance and operational data

See energy-efficient motors in the ENE BREF [132, COM 2009].

Cross-media effects

See energy-efficient motors in the ENE BREF [132, COM 2009].

Technical considerations relevant to applicability

Applicable where motors are used.

Economics

Reduced energy costs.

Driving force for implementation

Reduced energy costs.

Example plants

This technique is commonly reported in all FDM sectors [193, TWG 2015].

Reference literature

[39, Environment Agency of England and Wales 2001], [132, COM 2009], [193, TWG 2015]

2.3.2.1.10 Combustion regulation and control**Description**

Combustion regulation and control can be used to control boiler combustion by monitoring and controlling fuel flow, air flow, oxygen levels in the hot gas and heat demand.

Technical description

Excess air can be minimised by adjusting the air flow rate in proportion to the fuel flow rate. This is greatly assisted by the automated measurement of oxygen content in the hot gases. Depending on how fast the heat demand of the process fluctuates, excess air can be manually set or automatically controlled. Too low an air level causes extinction of the flame, then re-ignition and backfire, causing damage to the installation. This improvement minimises the heat loss due to unburnt gases and to elements in solid wastes and residues from combustion, e.g. through the slag. More information on optimisation of combustion and advanced control systems can be found in the ENE BREF [132, COM 2009] and the LCP BREF [145, COM 2017].

Achieved environmental benefits

Reduced energy consumption and emissions to air.

Environmental performance and operational data

There will be an initial set-up stage, with periodic recalibration of the automatic controls.

Cross-media effects

As excess air is reduced, unburnt components like carbonaceous particulates, carbon monoxide and hydrocarbons are formed and may exceed emission limit values. This limits the possibility of energy efficiency gain by reducing excess air. In practice, excess air is adjusted to values where emissions are below the limit value.

Technical considerations relevant to applicability

Generally, there are no technical restrictions to the applicability of this technique.

Economics

No information provided.

Driving force for implementation

Reduced energy costs.

Example plants

This technique is commonly reported in many of the FDM sectors [193, TWG 2015].

Reference literature

[132, COM 2009], [145, COM 2017], [193, TWG 2015]

2.3.2.2 Techniques related to steam systems

2.3.2.2.1 Standard and condensing economiser

Description

Heat exchanger which reduces steam boiler fuel requirements by transferring heat from the hot gas to the incoming feed water.

Technical description

The economiser is already a very common and standard solution to recover energy in steam boilers and other heat sources. Very briefly, it is a heat exchanger located in the hot gas of combustion, which can be useful for low-grade heat applications, such as water preheating. There are two types of economisers: standard and condensing. Hot gases contain water vapour from combustion. A standard economiser uses the remaining hot gas heat above the condensation temperature of this vapour (sensible heat), whereas a condensing economiser extracts heat from hot gases below the condensation temperature of this vapour (thus also recovering the latent heat). This condensed vapour mixes with sulphur and NO_x from the combustion, becoming acidic; therefore the condensing economiser, despite allowing a higher energy recovery, is more expensive as it requires acid-proof material (stainless steel).

Achieved environmental benefits

Reduced energy consumption.

Environmental performance and operational data

An economiser has to be designed and fitted according to the boiler design, and this will define its working range and conditions for maximum efficiency. Water preheating should be limited to avoid boiling, by ensuring a minimum flow through the economiser. Flue-gases should not be cooled below the condensation point, except for the case of a condensing economiser.

Cross-media effects

Only in the case of a condensing economiser, a small amount of low-pH waste water, from the combustion water condensation, is generated.

Technical considerations relevant to applicability

Generally, there are no technical restrictions to the applicability of this technique.

Economics

The total cost depends on the size of the boiler, as well as the configuration of the boiler and the boiler house. For a small industrial boiler consuming 15 000 MWh of gas annually, the cost can be in an order of magnitude of EUR 50 000, and EUR 20 000 of annual savings [193, TWG 2015].

Driving force for implementation

Reduced energy costs.

Example plants

This technique is commonly reported in many of the FDM sectors [193, TWG 2015].

Reference literature

[193, TWG 2015]

2.3.2.2.2 Minimisation of the blowdown from the boiler

Description

Measures such as pretreating the water, maximising the recovery of condensate, using an automated blowdown control system, or flashing the blowdown at medium or low pressure.

Technical description

The blowdown of a boiler is used to limit the accumulation of salts (e.g. chlorides, alkalis and silicic acid) and is, therefore, necessary to keep these parameters within prescribed limits. It is also used to remove the sludge deposits (e.g. calcium phosphates) and corrosion products (e.g. ferric oxides) from the boiler and to keep the water clear and colourless. Waste water at high pressure and temperature is always discharged, either for a set time or continuously. It is, therefore, preferable to restrict the blowdown as far as possible.

The total dissolved solids content of the boiler water is best kept as close as possible to the maximum authorised value. This can be done via an automated system consisting of a conductance probe in the boiler water, a blowdown regulator or a blowdown regulating valve. The conductance is continually measured. If the measured conductance exceeds the maximum value, then the regulating valve is opened more.

Instead of routinely discharging condensate to the WWTP because of the risk of contamination, the condensate can be collected in an intermediate tank and analysed to detect the presence of any contaminant. Pretreatment by reverse osmosis can allow lower boiler blowdown rates and hence lower energy losses. Energy needed for reverse osmosis is only electrical, i.e. to put water under pressure so that it can be pushed through the osmosis membrane ($< 0.001 \mu\text{m}$). A reduction of pretreatment of the boiler feed water with chemicals is also achieved [193, TWG 2015].

Additional measures to minimise the blowdown of a boiler can be found in the ENE BREF [132, COM 2009].

Achieved environmental benefits

Reduced energy consumption. Reduced waste water generation.

Environmental performance and operational data

Table 2.40 shows the potential fuel savings that can be achieved by reducing the blowdown as a function of steam pressure in the deep freezing of vegetables. At a steam pressure of 10 bar, a fuel saving of 2.1 % can be achieved if the blowdown volume is reduced by 10 %.

Table 2.40: Potential savings by reducing boiler blowdown in the deep freezing of vegetables

Effective boiler pressure (bar)	Fuel saving per blowdown reduction (%)
7	0.19
10	0.21
17	0.25

Source: [192, COM 2006]

Calculations indicate that energy in the condensate can be from 10 % to 20 % of the total steam energy content of a typical system, meaning that returning this would mean significant energy savings. Maximising the return of hot condensate to the boiler reduces the operating costs of the boiler(s). The very best operating plants return from 80 % to 90 % of the steam generated as hot condensate. The average bottling plant returns from 70 % to 80 % of the steam generated as hot condensate and the below average plants return below 70 % of the steam generated as hot condensate [98, TWG 2017].

Cross-media effects

Discharges of treatment chemicals, chemicals used in deioniser regeneration, etc.

Technical considerations relevant to applicability

Applicable where a boiler is used.

Economics

The payback of condensate return will depend on the condensate flow rates and temperature [98, TWG 2017].

Driving force for implementation

Reduced energy costs.

Example plants

This technique is commonly reported in installations belonging to dairies and the fruit and vegetables and oilseed sectors [193, TWG 2015].

Reference literature

[14, VITO et al. 2001], [15, Van Bael J. 1998], [98, TWG 2017], [132, COM 2009], [192, COM 2006], [193, TWG 2015]

2.3.2.2.3 Avoidance of losses of flash steam from condensate return

Description

Steam trap surveys based on acoustic, visual, electrical conductivity or thermal checks.

Technical description

When condensate is discharged from steam traps and flows along the return pipework, some flash steam is formed. Often flash steam is vented to the air and the energy it contains is lost. It may be possible to capture and use the flash steam, e.g. in the boiler.

Leaking steam traps lose significant quantities of steam, which result in large energy losses. Proper maintenance can reduce these losses in an efficient manner. In steam systems where the steam traps have not been inspected in the last three to five years, up to about 30 % of them may have failed, allowing steam to escape. In systems with a regularly scheduled maintenance programme, less than 5 % of the total number of traps should be leaking.

There are many different types of steam traps and each type has its own characteristics and preconditions. Checks for escaping steam are based on acoustic, visual, electrical conductivity or thermal checks. Leak detection in steam and compressed air systems can also be performed with the use of an ultrasound-measuring microphone [193, TWG 2015].

Achieved environmental benefits

Reduced energy and water consumption.

Environmental performance and operational data

The flash steam typically contains about 40 % of the energy in the original pressurised condensate. More operational data can be found in the ENE BREF [132, COM 2009].

Cross-media effects

There are no cross-media effects associated with this technique.

Technical considerations relevant to applicability

Applicable where flash steam is produced and can be reused.

Economics

No information provided.

Driving force for implementation

Reduced energy costs.

Example plants

This technique is commonly reported in many of the FDM sectors [193, TWG 2015].

Reference literature

[39, Environment Agency of England and Wales 2001], [132, COM 2009], [193, TWG 2015]

2.3.2.2.4 Multistage evaporation**Description**

Introduction of evaporated vapours to the next stage of the evaporator in which the temperature and the pressure are lower than in the previous one.

Technical description

Evaporators may operate in a single stage or evaporation may take place in stages using several evaporators operating in series. Each evaporator is referred to as an effect. With multistage or multi-effect evaporator systems, the product output from one effect in the evaporator is the feed for the next effect, and the high-temperature vapour that is removed from one effect of the evaporator is used to heat the lower-temperature product in the next evaporator effect. The energy efficiency of multistage evaporator systems can be improved by mechanical vapour recompression (MVR) and/or thermal vapour recompression (TVR). More information on these techniques is available in the ENE BREF [132, COM 2009].

The surfaces within the evaporator are heated by steam, which is injected into the top of the evaporator space. This uses fresh steam or exhaust gases from other operations to boil off water vapour from the liquid in the first stage and is an example of energy recovery/reuse.

The evaporated water still has sufficient energy to be the heat source for the next stage, and so on. Vacuum is applied in a multi-effect chain to enable the water to boil off. The liquid being processed is passed through a series of evaporators so that it is subject to multiple stages of evaporation. In this way, one unit of steam injected in the first evaporator might remove three to six units of water from the liquid. The energy savings increase with the number of evaporation stages. Up to seven stages can be operated in series, but three to five is more common. In the final stage, cooling using cooling water may condense the vapour. Some of the vapours can be drawn off the evaporators to be used as heat sources for other process requirements.

In order to achieve further steam efficiency, the vapour leaving each evaporation stage can be compressed to increase its energy before it is used as the heating medium for the subsequent evaporator.

Achieved environmental benefits

Reduced energy consumption, e.g. by introducing evaporated vapours to the next stage of the evaporator in which the temperature is lower than the previous one.

Environmental performance and operational data

As the heat is used for the next evaporation stage, multistage evaporators save energy. In contrast, single-stage evaporation does not enable the heat to be recovered.

Steam requirements for single-stage evaporators are 1.2–1.4 t/t of evaporated water.

Table 2.41 shows a comparison of energy consumption data for different numbers of evaporators using TVR (see Section 2.3.2.2.4.2). Further energy savings can be made using mechanical vapour recompression (MVR, see Section 2.3.2.2.4.1), as can also be seen in the table.

Table 2.41: Comparison of efficiencies of multi-effect evaporators in the dairy industry

Type of evaporator	Total energy consumption (kWh/kg water evaporated)
TVR 3 stages	0.140
TVR 4 stages	0.110
TVR 5 stages	0.084
TVR 6 stages	0.073
TVR 7 stages	0.060
MVR single-stage	0.015
<i>Source: [192, COM 2006]</i>	

It is reported that, in the sugar sector, the sugar juice resulting from purification has a 15 % dry matter content and it is necessary to raise this dry matter content to extract the sugar. The evaporation process allows the dry matter content to be increased from 15 % to more than 68 %. It is based on the principle of heat exchange between the sugar juice and the steam produced in a boiler. A multistage evaporator produces the heat exchange that takes place between the sugar juice and the low-pressure steam. This recycles the steam obtained from the juice after the first exchange. In practice, the low-pressure steam from the generator is condensed after undergoing a heat exchange and returns to supply the boiler. Following the same exchange, part of the water of the sugar juice evaporates and the steam produced in this way heats the second effect, in which a new part of the water evaporates. The effects follow on from each other in this way. The operation can be repeated up to six times in all. A decreasing level of pressure and temperature from one effect to the other allows the operation to be repeated several times with approximately the same amount of energy.

An example large dairy produces dried products, fresh products, semi-hard cheese and butter. The total quantity of milk processed in 2000 was around 321 000 litres and the total production of milk and whey powder amounted to around 19 000 tonnes. In this dairy, both a single-stage evaporator and a five-stage falling film evaporator are used. The single-stage evaporator has an input capacity of 30 000 l/h and uses MVR for pre-concentration and TVR for concentration. The five-stage evaporator has an input capacity of 22 000 l/h and uses TVR for pre-concentration and concentration. Energy savings were reported using the five-stage evaporator.

Cross-media effects

No information provided.

Technical considerations relevant to applicability

Applicable in the sugar industry; in starch processing; in tomato, apple and citrus juice concentration; and in the evaporation of milk and whey.

Economics

See Section 2.3.2.2.4.1.

Driving force for implementation

Reduction in energy costs.

Example plants

This technique has been reported mainly in the animal feed, dairy, starch and sugar sectors [193, TWG 2015].

Reference literature

[19, German Dairy Association 2001], [31, CEFS 2001], [35, Germany 2002], [132, COM 2009], [192, COM 2006], [193, TWG 2015]

2.3.2.2.4.1 Mechanical vapour recompression (MVR)

Description

The evaporated vapour is compressed by a mechanical compressor and then reused as a heat source.

Technical description

In MVR, the evaporated vapour is compressed by a mechanical compressor and then reused as a heat source. The latent heat is higher than the power input of the compressor and a large COP is available. With MVR, all the vapour is compressed, so a high degree of heat recovery is achieved. The system is driven by electricity, but needs a steam-heated finisher to attain high temperatures. Two types of compressors are in operation, i.e. a fan and a high-speed turbine. In practice, the fan is the most widely used compressor type as it has better energy efficiency. The principle of an MVR operation is shown in Figure 2.7.

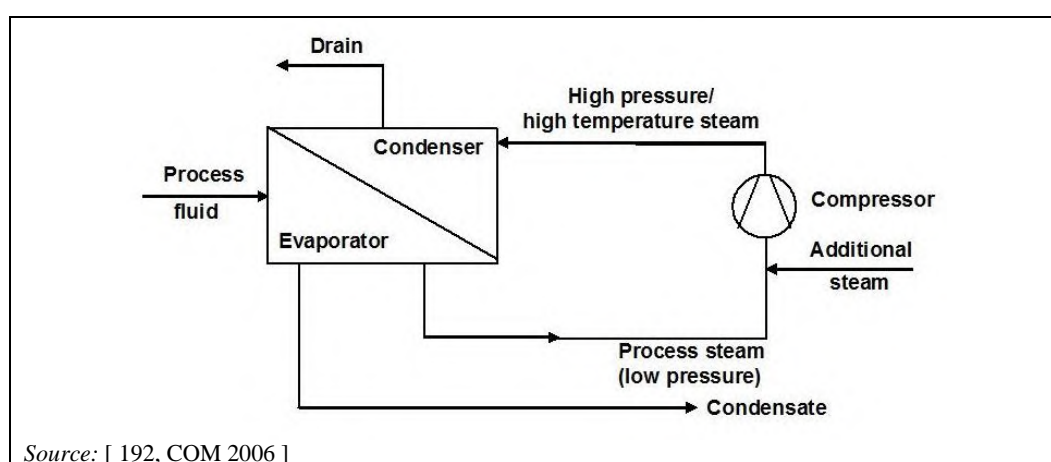

Figure 2.7: MVR evaporator principle

Achieved environmental benefits

Reduced odour emissions. Reduced energy consumption compared to TVR (see Section 2.3.2.2.4.2). Reduced cleaning requirements due to less build-up of burned product.

Environmental performance and operational data

It is reported that the energy consumption of a MVR evaporator is approximately 10 kWh/t of water evaporated, with negligible steam consumption. As all of the vapour is recompressed, rather than just a portion of it, as is the case with TVR evaporators, a higher degree of heat recovery is achieved. Also, a lower evaporation temperature is needed, which means less product burnout. Figure 2.9 shows that higher energy savings can be undertaken using MVR compared to TVR.

An example Japanese dairy upgraded its milk powder process and installed a four-stage MVR evaporator to replace its existing four-stage TVR evaporator. When the MVR system was adopted, it was necessary to both maintain the designed evaporation capacity and to prevent milk being scorched and contaminating the surfaces of the heat transfer pipes in the evaporator. A falling film evaporator and an automated control system to control operating parameters, e.g. flow rate, temperature and pressure, were installed. The MVR has operated successfully with an overhaul every 2 years. Savings in the operating costs of up to 75 % were achieved, mainly as a result of the reduced steam consumption. Figure 2.8 illustrates the new four-stage MVR evaporator.

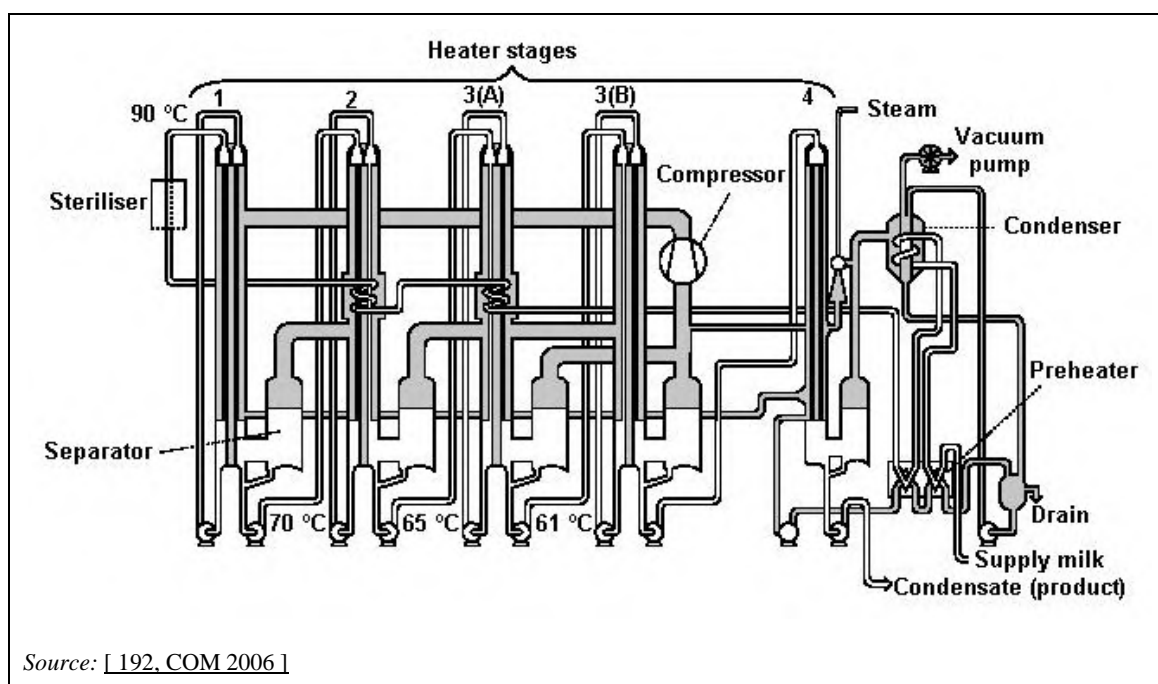

Figure 2.8: Flow chart of a four-stage MVR milk evaporator system

In an example Finnish dairy, a MVR system draws all the vapour out of the evaporator and compresses it using mechanical energy before returning it to the evaporator. No thermal energy is supplied, except for the steam required for the start-up. The only electricity required is for the operation of the evaporator. In this installation, the MVR can evaporate 100–125 kg of water using 1 kW of energy.

In an example brewery in Germany, the vapour condensation system draws off the boiling vapours produced by the wort boiling process from the whirlpool pan and compresses them with MVR. The compressed vapours are reused as a heating medium for the boiling process. The advantages of condensing the vapours include reductions in the heat and water losses, improvements in the hot water balance of the operation and a reduction in odour emissions. It is reported that approximately one third of the electrical energy consumed by the brewhouse has to be used to drive the vapour compressor system.

Cross-media effects

Electricity is needed to power the vapour compressor. MVR generates noise, so sound insulation is required.

Technical considerations relevant to applicability

Applicable in sugar manufacturing; starch processing; tomato, apple and citrus juice concentration; brewing; and in the evaporation of milk and whey. Most new evaporators are equipped with a MVR system.

Economics

As MVR systems are driven by electricity rather than steam, operating costs are considerably lower compared to TVR. For example, the operating costs of a three-stage MVR evaporator are approximately half those of a conventional seven-stage TVR evaporator. The difference in operating costs for TVR and MVR increases with the capacity of the evaporator, as illustrated in Figure 2.9.

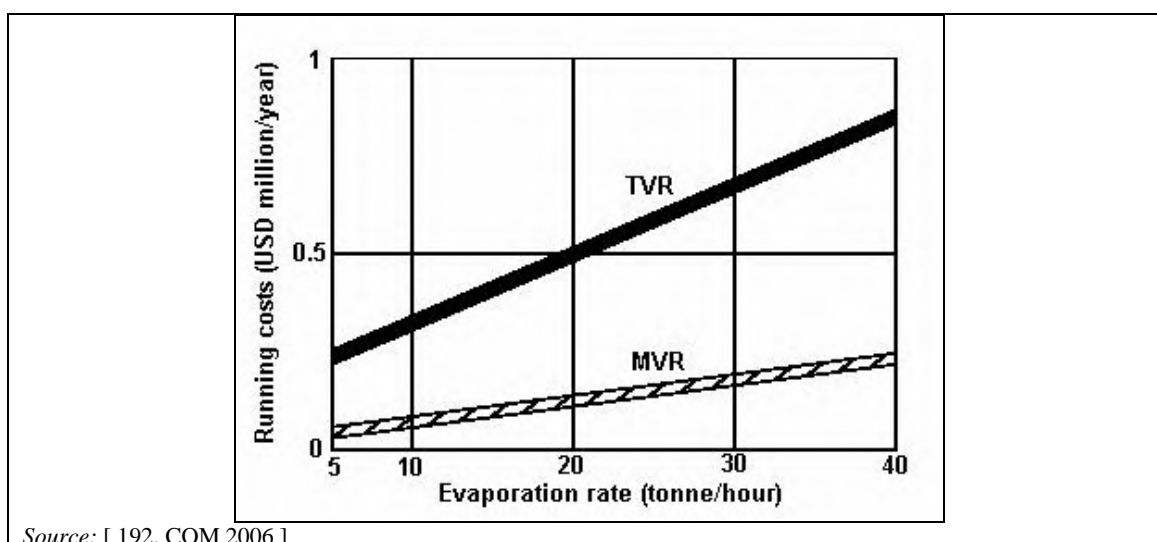

Figure 2.9: Comparison of the operating costs of TVR and MVR evaporators

In the example Japanese dairy, the cost of the new MVR evaporator was EUR 1.5 million, compared with EUR 1.3 million for a new TVR evaporator. At an evaporation rate of 30 t/h, the annual operating costs of the MVR evaporator were EUR 175 000, compared with previous annual operating costs of EUR 680 000 for the TVR evaporator, i.e. savings of nearly 75 %.

Driving force for implementation

Reduction in energy costs.

Example plants

MVR is implemented in installations #254, #281, #282, #341, #345, #414, #415, according to the FDM data collection [193, TWG 2015].

Reference literature

[19, German Dairy Association 2001], [21, Nordic Council of Ministers 2001], [35, Germany 2002], [40, UNEP et al. 2000], [70, CADDET 1992], [192, COM 2006], [193, TWG 2015]

2.3.2.2.4.2 Thermal vapour recompression (TVR)

Description

Water vapor from an evaporator is entrained and compressed with high pressure steam in a thermocompressor so it can be condensed in the evaporator heat exchanger.

Technical description

TVR makes use of steam injection compressors to compress the vapour. Steam injection compressors may have fixed or variable injection nozzles. The thermal energy needed for compression is live steam from a boiler.

The live steam passes through the injection nozzle and is throttled to the pressure level of the receiving vapour. Vapour is entrained as a result of the difference in speed. Vapour and live steam are mixed in the mixing chamber. Changing the flow aperture in the diffuser determines the pressure at which the mixed steam leaves the steam injection compressor.

Achieved environmental benefits

Reduced energy consumption and odour emissions.

Environmental performance and operational data

By comparison with MVR, TVR offers the advantages of having no moving parts and greater reliability in operation. It is reported that TVR allows for long production cycles and a reduction in cleaning frequency.

Cross-media effects

Higher energy consumption than MVR.

Technical considerations relevant to applicability

Applicable in sugar manufacturing; starch processing; tomato, apple and citrus juice concentration; brewing; and in the evaporation of milk and whey.

Economics

Lower purchase cost but higher operating costs than MVR.

Driving force for implementation

Reduction in energy costs.

Example plants

TVR is implemented in installation #341, according to the FDM data collection [193, TWG 2015].

Reference literature

[19, German Dairy Association 2001], [35, Germany 2002], [70, CADDET 1992], [193, TWG 2015]

2.3.2.3 Techniques related to compressed air

2.3.2.3.1 Reduction of air leaks and optimisation of pressure settings

Description

Leak prevention measures and periodic leak tests are carried out. The pressure at the compressor is set at the maximum required and then regulated at each individual application.

Technical description

Consumption losses during production downtime can be avoided by sectorisation of pressure (multiple changes to the pressure distribution). Several additional techniques can be implemented to optimise compressed air generation and use [193, TWG 2015], [203, FEFAC 2015]:

- replace pneumatic installations with electric ones;
- use a variable speed compressor;
- adjust the pressure level (more pressure is provided with a separate compressor);
- adapt the compressor to the need (flow/pressure).

More measures to reduce compressed air system leaks can be found in the ENE BREF [132, COM 2009].

The pressure at the compressor can be set at the maximum required and then regulated at each individual application to minimise the energy required to produce compressed air and reduce leakage. For applications which require higher pressures or have longer operating hours than the majority of the applications which use compressed air, it may be more energy- and cost-effective to install a dedicated compressor [39, Environment Agency of England and Wales 2001].

The required pressure can be obtained through a specific study where a detailed inspection (e.g. on a yearly basis) of the air-compressed line is carried out in order to look for and reduce any air leaks [193, TWG 2015].

Achieved environmental benefits

Reduced energy consumption and reduced noise, if large compressors run for shorter periods.

Environmental performance and operational data

In a grain milling installation with a permitted production capacity of around 500 tonnes/day the energy losses were reduced by 10 % [193, TWG 2015].

Cross-media effects

No information provided.

Technical considerations relevant to applicability

Generally, there are no technical restrictions to the applicability of this technique.

Economics

In a grain milling installation with a permitted production capacity of around 500 tonnes/day the cost of implementation was EUR 7 000, and the technique also achieved annual savings of EUR 7 000 [193, TWG 2015].

Driving force for implementation

Reduced energy costs.

Example plants

This technique is commonly reported in all FDM sectors [193, TWG 2015].

Reference literature

[39, Environment Agency of England and Wales 2001], [132, COM 2009], [193, TWG 2015], [203, FEFAC 2015]

2.3.2.4 Techniques related to cooling/freezing

2.3.2.4.1 Optimisation of condensation and evaporation temperature of cooling systems

Description

The condensation and evaporation temperatures are set according to the requirements of the cooling system.

Technical description

The reduction of the condensation temperature raises the COP and lowers the electricity consumption. This reduction can be achieved by fitting an adequate capacity of condenser batteries so that, even in summer, sufficiently low condensation temperatures can be achieved.

Low temperatures can also be achieved by keeping the condensers clean and replacing badly corroded ones. Blocked condensers cause the condensing temperature to increase and the cooling capacity also drops, so the required temperature may not be achieved.

Ensuring that air entering the condensers is as cold as possible also contributes to lowering the condensation temperature. The warmer the air entering the condenser, the higher the condensing temperature. This can be minimised by shading the condensers if necessary, ensuring that warm air is not recirculated, removing anything which obstructs the airflow and freezing at night.

Additionally, raising the evaporation temperature improves energy performance. To do this, a simultaneous optimisation of various freezing tunnels can be carried out, as shown in Figure 2.10. This optimisation needs to be undertaken again after a tunnel is shut down, a different product is processed and another flow rate is set.

Achieved environmental benefits

Reduced energy consumption.

Environmental performance and operational data

Lowering the condensation temperature by 1 °C raises the COP by 2 %. Lowering the condensation temperature by 5 °C causes the electricity consumption to fall by 10 %.

It is reported that if the evaporator temperature is raised by 1 °C, the COP rises by 4 % and the refrigeration capacity rises by 6 %.

A Flemish study on energy consumption during the freezing of vegetables in a freezing tunnel showed that the greatest savings can be achieved by adjusting the evaporator temperature, the residence time of the vegetables in the freezing tunnel, the air flow rates relative to the vegetable flow rate and the type of vegetables. This study shows that it is not always necessary to set the evaporator temperature at the lowest level, i.e. -40 °C, for good freezing quality. Furthermore, it is very important to monitor the temperature of the product after it has gone through the freezing tunnel. Low temperatures, i.e. < -18 °C, are not necessary as the vegetables will ultimately be stored in a confined space at -18 °C. High temperatures, i.e. > -16 °C, lead to lower freezing qualities. In a worst-case scenario, the whole mass can freeze together during storage in crates. The conclusions of the study are summarised in Figure 2.10.

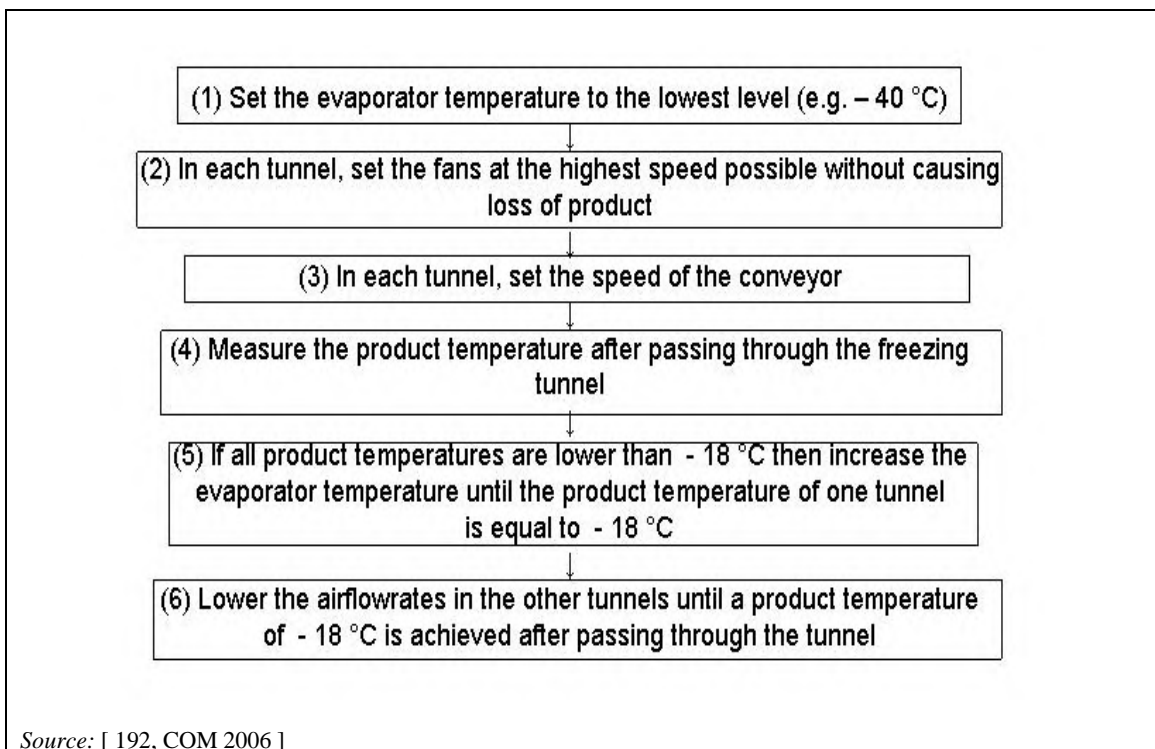

Source: [192, COM 2006]

Figure 2.10: Optimising the freezing tunnels in the production of deep-frozen vegetables

With reference to Figure 2.10:

- 1) The evaporator temperature of the freezing unit is set to the lowest position, e.g. -40 °C.
- 2) The fans are set to the maximum air flow rate permissible without product loss. If the air-regulating valves are fully opened or the rotation speed adjustment is set at maximum frequency, product is blasted out of the bed. Then, the valves are closed more or the frequency is lowered.
- 3) In adjusting the speed of the conveyor belt, inversely proportional to the residence time on the belt, care is taken to ensure that the layer thickness is not too low. This always leads to the formation of preferential air channels in the vegetable bed, which means

that the rest of the bed receives little airflow. The layer thickness is not set too high either, since this leads to block freezing of the lower layers. As the pressure drop over the vegetable bed rises, the air speeds fall with lower heat removal.

- 4) The product temperature in each freezing tunnel is measured. To take the measurement, an insulated container is filled with product. The reading is taken as soon as the temperature stabilises. Immediately after freezing, the outer temperature is lower than the centre.
- 5) If the product temperature is lower than $-18\text{ }^{\circ}\text{C}$ for each of the tunnels, then the evaporator temperature is set higher. This is repeated until the product temperature of one of the freezing tunnels is equal to $-18\text{ }^{\circ}\text{C}$. If, in one of the tunnels, the product temperature at the lowest position of the evaporator is higher than $-18\text{ }^{\circ}\text{C}$, then the vegetable flow rate of the tunnel concerned is lowered.
- 6) In the other freezing tunnels, the air flow rate is lowered if a product temperature of $-18\text{ }^{\circ}\text{C}$ is achieved.

Cross-media effects

No information provided.

Technical considerations relevant to applicability

Generally, there are no technical restrictions to the applicability of this technique.

Economics

No information provided.

Driving force for implementation

Reduced energy costs.

Example plants

This technique is reported in dairies, fruit and vegetables, and oilseed installations [193, TWG 2015].

Reference literature

[14, VITO et al. 2001], [15, Van Bael J. 1998], [39, Environment Agency of England and Wales 2001], [192, COM 2006], [193, TWG 2015]

2.3.2.5 Techniques related to cleaning

2.3.2.5.1 Optimisation of chemical dosing and water use in CIP

See Section 2.3.3.2.4.

2.3.2.6 Techniques related to cooking

2.3.2.6.1 Avoidance of precooking step if possible

Description

Avoidance of the precooking step if the food can be cooked subsequently during the sterilisation step.

Technical description

Before preservation in cans, bottles and jars, the food can be cooked before it is placed into the packaging container. Water baths, showers, steam, hot air and microwave ovens are used for such precooking. Precooking can be avoided if the food can be cooked subsequently, during sterilisation.

Achieved environmental benefits

Reduced water and energy consumption. Reduced waste water generation and pollution.

Environmental performance and operational data

In the fish sector, medium-sized and large fish are, for example, cooked before canning. Small fish such as sardines are canned whole and are then cooked in the cans during sterilisation. The circumstances which enable precooking to be avoided and cooking to take place during the sterilisation step depend on factors such as the size of the food pieces; the size of the cans, bottles or jars; the recipe; ensuring the quality of the product and the length of the sterilisation time.

Cross-media effects

No information provided.

Technical considerations relevant to applicability

Widely applicable in the FDM sector for foods that are intended to be preserved and cooked.

Economics

No information provided.

Driving force for implementation

Reduction in energy costs.

Example plants

No information provided.

Reference literature

[71, AWARENET 2002]

2.3.3 Techniques to reduce water consumption

2.3.3.1 General processing techniques

2.3.3.1.1 Water recycling and/or reuse

Description

Recycling or reuse of water streams (preceded or not by water treatment), e.g. for cleaning, washing, cooling or for the process itself.

Technical description

Recycling/reuse of water can be carried out either preceded or not preceded by water treatment. Examples are given for both options under Environmental performance and operational data below.

Achieved environmental benefits

- Reduction of water consumption (e.g. water of drinking water quality) by using water sources of a different quality.
- Reduction of emissions to water.
- The technique can also enable heat to be recovered (e.g. condensate return).

Environmental performance and operational data

There are multiple ways of reusing water reported in the questionnaires of the FDM BREF data collection [193, TWG 2015]. Some examples are as follows:

- Cooling water is recycled as cleaning water. This is the case for installation #036.
- Hot water generated from cooling systems is recycled in the process. This is the case for installation #048 (reused in the mashing-in in beer production).

- Water generated from beet sugar processing is recycled, e.g. as cooling and cleaning/washing water. This is the case for installations #027, #087, #111, #125 and #285.
- Washing water is reused several times for the same or different washing. This is the case for installations #181, #279 and #283.
- Cooling water is reused several times for cooling again (closed-circuit cooling, see also Section 2.3.3.3.1). This is the case for installations #228 and #291.
- Cooling water is recycled as boiler feed water. This is the case for installation #463.
- Cooling water is recirculated after electrochemical treatment. This is the case of installation #157 (see also Section 2.3.3.3.2).
- The last flush of the CIP cycle is reused as the first flush of the next CIP cycle. This is the case for installations #228, #229, #230 and #231.
- Water generated from RO filtration of raw materials (e.g. condensate of whey) is recycled. This is the case for installations #124, #125, #130, #134, #232 and #303.
- Waste water, after being biologically treated, is recycled as cleaning or cooling water. This is the case for installations #035, #114 and #305.
- Condensates generated in evaporation and drying operations after being filtered with RO is recycled. This is the case for installations #051, #124, #292 and #296.
- Waste water, after being biologically treated and filtered by using ultrafiltration followed by reverse osmosis, is recycled. This is the case for installations #035 and #310.
- Rinsing water after cleaning is reused for pre-rinsing. This is the case for installation #058.
- Rinsing water after cleaning is recycled for the pasteuriser. This is the case for installation #247.
- Rinsing water after cleaning is recycled for auxiliary services. This is the case for installation #183.
- Rinsing water after cleaning is recycled for cooling. This is the case for installation #279.
- The condensate from vapour generation is partly recycled as process water after energetic usage. This is the case for installation #087.
- Waste water after physico-chemical treatment is recycled in a biofilter and bioscrubber. This is the case for installation #466.
- Waste water is evaporated and reused in the process. This is the case for installation #086.
- Rainwater is recycled. This is the case for installation #035.
- Recovered condensate can be recycled as feed to the boiler, heated water, or heated water for cleaning equipment and other installations (see also Section 2.3.3.5.1).
- Waste water is recycled from the lauter turn in breweries (see also Section 4.4.2.2).
- Reuse of bottle pasteurising water in breweries (see also Section 4.4.2.3).
- Scaling waste water is filtered and recirculated for preliminary fish rinsing in fish and shellfish processing (see also Section 7.4.1.1.2).
- Water that arises from peeling, sorting and canning is recycled.
- Countercurrent water is reused in starch washing (see also Section 14.4.2.1).
- Flume water used for transporting beet is reused through the initial stages of the process. Retained water from the previous year's campaign is reused to start the new campaign. Condensates from the evaporation and crystallisation stages are reused as process water in several stages, including beet washing (see also Section 15.4.2.1).
- Optimising the CIP systems can, for example, minimise the quantity of the cleaning and disinfection agents used, by recirculating cleaning solutions (containing for example caustic soda).
- In fruit and vegetable processing, recycling of water is common practice, sometimes with some treatment, such as filtration, during the unit operations prior to blanching.

Cross-media effects

Increase in recycling/reuse of water can result in an increase in energy and chemical consumption for treatment of water before recycling.

Technical considerations relevant to applicability

Water recycling/reuse opportunities are present in existing and new FDM installations. Hygiene and food safety requirements may compromise the applicability of this technique, in particular for the meat sector.

Economics

No information provided.

Driving force for implementation

- Reduced consumption of drinking quality water in regions with water shortages.
- In line with the EU Action Plan for the Circular Economy [180, COM 2015], reuse of process and waste water aims to improve the resource efficiency of the FDM sector.

Example plants

Water recycling/reuse is commonly reported in all FDM sectors.

Reference literature

[180, COM 2015], [193, TWG 2015], [226, EDA 2016]

2.3.3.1.2 Optimisation of water flow

Description

Use of various control devices, e.g. photocells, flow valves, thermostatic valves, to adjust the water flow.

Technical description

Flow measurement and control techniques can reduce material waste and waste water generation in FDM processing. Applying flow measurement and control in transfer lines allows the accurate addition of materials to storage and processing vessels and filling packaging, thereby minimising the excessive use of materials and the formation of out-of-specification products.

Sensors such as photocells can be fitted to detect the presence of materials and to supply water only when it is required. Water supplies can be turned off automatically between products and during all production stoppages.

Valves are the most common control device and they are extensively used with both manual and automatic control systems. Valves are often used to modify a flow rate to control a different process parameter, e.g. the temperature of chocolate can be measured and, if necessary, adjusted by controlling the flow rates of heating and cooling water. Examples include flow regulators and solenoid valves; others are available.

Flow regulators are used to provide a constant flow at a predetermined rate. The flow through the regulator can be adjusted within a limited range, but these devices are designed with the intention that adjustments are infrequent.

Solenoid valves are two-position devices where a solenoid is used to open or close a valve on receipt of a control signal.

Examples of the general applicability of flow measurement and control are shown in Table 2.42.

Table 2.42: Examples of the use of flow control in the FDM sector

Equipment	Condition/activity	Reason for control
Transfer lines	Accurate addition of materials to reaction vessels	Minimise excessive use of materials and formation of out-of-specification products
Steam supplies	Maintaining correct operating temperatures	Minimise waste from underheated or overheated materials and products
Cleaning systems	Water use	Optimise use and minimise waste water generation

Source: [192, COM 2006]

Some typical applications of flow measurements are shown in Table 2.43.

Table 2.43: Typical applications of flow measurements in the FDM sector

Product/activity	Application
Soft drinks	Flow measurement and feedback control for raw material addition
Bulk solids	For example, determining the flow of potato crisps to a flavour drum to ensure the correct ratio of flavouring
Milk powder	Flow measurement for accurate batching of ingredients into the process as specified in recipes
CIP	Flow measurement to ensure a fixed volume of water issued for each cleaning stage

Source: [192, COM 2006]

Achieved environmental benefits

Reduced water consumption and associated energy use.

Environmental performance and operational data

An example food manufacturing company identified that excessive water consumption by its vacuum pumps was due to a higher flow than necessary for the seal water. Although the maximum flow for the service liquid should have been 2.7 m³/h, the actual flow was almost 11.5 m³/h, i.e. over four times the design requirement. Installing constant flow valves to ensure the correct flow rate to each of the water ring vacuum pumps reduced water use by approximately 60 000 m³/year, corresponding to 7.5 % of the site's mains water consumption. Water and waste water costs fell and there was reduced energy consumption and wear of the vacuum pumps.

At an example chicken processing company, excessive water consumption was identified. Flow regulators were installed to fix the water supply to particular processes at the rate required by the process, thereby saving on water consumption.

An example fish processing company installed a solenoid system on the water supply to a prewash system. Water had previously flowed continuously, causing overflowing and entrainment of debris into the waste water. The solenoid enabled the water supply to be shut off when the conveyor belt was not in use. Water used by the process fell by 40 %.

In a brewery installation (#160), a vacuum is applied in bottles just before filling by a vacuum pump. Water flow is led into the pump to produce a venturi effect to take air out of the filler and also refrigerate the pump. There is a relationship between the vacuum generated by the pump and its working temperature, which is controlled by the cooling water. Using a thermostatic valve to adjust the raw water supply, it is possible to control the vacuum and save water. Water savings close to 0.1 hl/hl of products have been achieved [193, TWG 2015].

Cross-media effects

There are no cross-media effects associated with this technique.

Technical considerations relevant to applicability

Flow regulators are widely applicable, where a constant flow is required at a set rate.

The use of solenoid valves is applicable throughout the FDM sector and they are frequently used to control water supply.

Economics

The introduction of constant flow valves in the food manufacturing installation referred to resulted in costs falling by GBP 70 000/year, giving a payback on the investment in less than one month.

At the chicken processing installation, the introduction of flow regulators cost less than GBP 1 000 and resulted in water savings worth over GBP 10 000/year.

At the fish processing installation, the 40 % reduction in water use saved GBP 2 500/year and gave a payback period of 5 weeks.

Driving force for implementation

Reduced water consumption and associated costs.

Example plants

Widely applied in the FDM sector.

Reference literature

[7, Environment Agency of England and Wales 2000], [10, Envirowise (UK) & Entec UK Ltd 1999], [192, COM 2006], [193, TWG 2015]

2.3.3.1.3 Optimisation of water nozzles and hoses

Description

Use of correct number and position of nozzles; adjustment of water pressure.

Technical description

Water nozzles are widely used in the FDM sector, e.g. for washing and sometimes for thawing the product, and cleaning the equipment during processing. Water consumption and waste water pollution minimisation can be carried out by correctly positioning and directing the nozzles. The use of presence-activated sensors and, most importantly, only installing them where required, can ensure that water is only consumed where necessary. Removing nozzles where water is used to direct food and replacing them with mechanical devices can reduce water consumption and the entrainment of food particles in water which would then have to be treated in a WWTP.

In addition, water consumption can be optimised by monitoring and maintaining the water pressure of the water nozzles. Water pressure can be adjusted according to the unit operation requiring the highest pressure, and a suitable pressure regulator can be installed at each of the other unit operations which require water.

Achieved environmental benefits

Reduced water consumption and waste water generation. Reduced waste water pollution, e.g. due to the reduction of the contact time between the food and water.

Environmental performance and operational data

When processing Vienna sausages, cooling is required after smoking. This is normally carried out by showering the sausages in the smoking cabinet or in a specially designated area. A large quantity of water is often used for this purpose if irrigation pipes are used. Water consumption is commonly around 3.5 m³/t. Instead of irrigation pipes, water-saving nozzles and a timer control are reportedly used. To avoid unnecessary waste, the nozzles have to be correctly positioned and directed so that all the water hits the sausages. When cooling is carried out in

cabinets specially designed for the purpose, the sausages can be sprayed with finely atomised water, the water supply is then stopped and air is pulled through the cabinet. This causes the water on the surface of the sausages to evaporate. As the surface dries out, a new cycle of water spraying and drying is started. The method results in substantial water savings.

Nozzles are also used when sausages are vacuum-packed. A vacuum-packing machine uses cooling water, approximately 0.2 m³/t of sausages. Setting the water quantity and fixing and locking the position of the nozzles minimises water consumption. Another possible alternative is to collect and reuse the cooling water.

In the fish sector, a reduction in water consumption of about 0.13–0.2 m³/t of raw material has been reported.

In white fish filleting, water consumption can be reduced by up to 90 % by installing nozzles and sprinkling the water for one or two seconds out of every three. In the sorting of herring and mackerel, a 50–65 % reduction in water consumption can be achieved by regulating the nozzle sizes so that they only supply the necessary amount of water.

It is reported that, in fish skinning and cutting, reducing both the number and size of spray nozzles can lead to water savings of about 75 %. In fish filleting, a reported reduction of 60 % to 75 % in water consumption is obtained by using the following means which combine a planned use of nozzles and other techniques:

- removing unnecessary water nozzles;
- using water nozzles instead of water pipes for washing the product;
- using mechanical devices instead of water nozzles to move the fish from the tail cut;
- replacing the nozzles for washing the driving wheels on the filleting part with mechanical scrapers;
- replacing existing nozzles by nozzles with a lower water consumption;
- using pulsating water nozzles, i.e. alternating the opening and closing of the water supply with an automatic valve;
- replacing the waste drain by mesh conveyors and closing the nozzles in the waste drain. The waste will be separated from the process water directly near the filleting machine, resulting in shorter contact time and less entrainment of, for example, fat;
- using presence-activated sensors to control when the nozzles operate;
- using dry transport of viscera and fat;
- removing skin and fat from the skinner drum by vacuum.

The frame can be cut from fish fillets by two sets of rotating knives. The knives may need to be cooled with water from nozzles, which can also clean off fish meat and scale, although it may be possible to do this mechanically.

Cross-media effects

There are no cross-media effects associated with this technique.

Technical considerations relevant to applicability

Applicable to all the FDM sectors. In the fish sector, nozzles are used in scaling, skinning, cutting, eviscerating, and filleting. In the meat sector, they are used in the processing of sausages. In brewing, they are used for cask and bottle cleaning.

Economics

No information provided.

Driving force for implementation

Reduction of costs associated with savings in water consumption.

Example plants

Widely applied in the FDM sector.

Reference literature

[13, Nordic Council of Ministers 1997], [20, Nordic Council of Ministers 2001],
[71, AWARENET 2002]

2.3.3.1.4 Segregation of water streams

Description

Water streams that do not need treatment (e.g. uncontaminated cooling water or uncontaminated run-off water) are segregated from waste water that has to undergo treatment, thus enabling uncontaminated water recycling.

Technical description

A detailed technical description of a waste water collection and segregation system can be found in the CWW BREF [168, COM 2016].

Contaminated waste water may be segregated to receive appropriate treatment according to its characteristics. It may then be possible for the high-volume, low-polluted streams to be either recycled following suitable treatment or discharged directly to the WWTP without treatment. In some cases, materials can be recovered from process water for use in the process or for other uses such as animal feed.

Uncontaminated water for which there is no reuse opportunity available should be discharged without treatment provided that the requirement on the recipient quality can be met. If that is not possible, it should be considered whether treatment of the specific water stream is an option, thus preventing an unnecessary load on the WWTP.

Achieved environmental benefits

The main benefits of the technique include lowering the volume of waste water requiring treatment and increasing the load of pollutants, thus enabling more efficient treatment (including reduced energy consumption) as well as allowing water and material recycling/reuse.

Environmental performance and operational data

Separate discharge is recommended to avoid a dilution effect of the treated waste water. The more concentrated the effluents that result from separation, the more generally effective their downstream treatment is.

Cross-media effects

There are no cross-media effects associated with this technique.

Technical considerations relevant to applicability

For existing installations, there might be technical and economic difficulties associated with the installation of a waste water separation/segregation system (see Economics below).

Economics

Segregation of waste water can involve a high capital cost at existing installations. However, this may be offset by the reduced operating costs due to the lower requirement for waste water treatment (e.g. water-holding capacity, energy consumption), whether on site, at a MWWTP or a combination of both. Waste water separation/segregation systems can be installed efficiently at new installations.

Driving force for implementation

- Reduction of long-term expenses for treating waste water.
- Enabling of water and material recovery.
- In some countries, the mixing of uncontaminated rainwater with other effluents is not permitted.

Example plants

Widely used in the FDM sector and any other industrial activity with waste water generation.

Reference literature

[168, COM 2016], [226, EDA 2016]

2.3.3.2 Techniques related to cleaning**2.3.3.2.1 Dry cleaning****Description**

Removal of as much residual material as possible from raw materials and equipment before they are cleaned with liquids, e.g. by using compressed air, vacuum systems or catchpots with a mesh cover.

Technical description

As much residual material as possible can be removed from raw materials, vessels and equipment before they are wet cleaned. This can be applied both during and at the end of the working period. All spillages can be cleaned up, by for example shovelling or vacuuming spilt material or by using a squeegee, prior to wet cleaning, rather than hosing them down the drain. This reduces the entrainment of material into water, which would consequently have to be treated in a WWTP. This is enhanced further by transporting materials such as ingredients, by-products and waste from processing as dry as possible.

Several techniques can be used to dry clean the raw vegetable materials before entering the installation. This step allows the removal of dry exogenous material such as stones, earth, leaves, etc. The plant is conveyed through a grid-wheel, which gently brushes the surface. Holes between the grids allow the elimination of earth and stones. Light material (leaves, flowers, stems) can be removed by ventilation: air is blown onto a conveyor which carries the product, and these light particles are lifted up, then sucked into the hood.

Dry cleaning is facilitated by, for example, providing and using catchpots with a mesh cover, making sure suitable, dry clean-up equipment is always readily available and providing convenient, secure receptacles for the collected waste. Catchpots may be locked in place to ensure that they are in position during cleaning. As well as manual dry cleaning of equipment and installations, other measures can be used, such as letting materials drain naturally, by gravity, into suitably located receptacles and by using pigging (see Section 2.3.3.2.2).

The cleaning procedure can be managed to ensure that wet cleaning is minimised and that the necessary hygiene standards are maintained. For example, the use of hoses can be prohibited until after dry clean-up.

Achieved environmental benefits

Reduced water consumption and volume of waste water. Reduced entrainment of materials in waste water and, therefore, reduced emission levels of COD and BOD for example. Increased potential for the recovery and recycling of substances generated in the process. Reduced use of energy needed to heat water for cleaning. Reduced use of detergents.

Environmental performance and operational data

Applied examples of this technique are:

- in sausage-making, ground meat residues from equipment such as bowl choppers, sausage fillers and from floors can be manually removed, to the maximum practical extent prior to cleaning and sent to a rendering installation for example, instead of being washed into the WWTP;
- in fish processing, dry cleaning of belts can be undertaken and result in less waste and water pollution being produced;
- in fruit and vegetable processing, product losses throughout the process can be shovelled up and sent for use as animal feed;
- the residues from wine processing, e.g. grape stems, pomace, marcs and lees can be collected separately before cleaning the equipment with water;
- catchpots over floor drains can be used to keep residues, e.g. grain and fruit skins, out of the drainage system;
- grain dust can be collected by vacuum systems, for example in flour mills, animal feed mills, breweries and distilleries;
- floors and open equipment can be pre-soaked to loosen dirt before cleaning;
- residual materials from pipework can be removed using compressed air (see Section 2.3.3.2.2);
- cleaning and disinfection of PET packaging without the use of water, e.g. with compressed air, ionised air, nitrogen peroxide (see Section 2.3.3.4.1).

When cleaning dusty materials, it is important to consider the risks associated with fire and explosion and with occupational health. Immediate removal may be necessary to safeguard hygiene and prevent microbiological risks.

Cross-media effects

Increased solid waste.

Technical considerations relevant to applicability

Applicable to all FDM installations.

Economics

No information provided.

Driving force for implementation

Reduced energy and water use, reduced need for waste water treatment and lower detergent use and expenditure.

Example plants

Many installations apply some dry cleaning prior to wet cleaning.

Reference literature

[1, CIAA 2002], [8, Environment Agency of England and Wales 2000], [14, VITO et al. 2001], [20, Nordic Council of Ministers 2001], [71, AWARENET 2002]

2.3.3.2.2 Pigging system for pipes

Description

Use of a system made of launchers, catchers, compressed air equipment, and a projectile (also referred to as a 'pig', e.g. made of plastic or ice slurry) to clean out pipes. In-line valves are in place to allow the pig to pass through the pipeline system and to separate the product and the rinsing water.

Technical description

Pigging is a system which is built into the existing pipe system (see Figure 2.11). This makes it possible to put a ‘pig’ into the pipes to separate product and rinsing water between different batches of product. The end product can thus be collected and used in the production of the same or a similar product.



Figure 2.11: Pigging system

The system comprises launchers, catchers, compressed air equipment and in-line valves to allow the pig to pass through the system. One-piece food-grade rubber pigs are propelled along from a launcher using compressed air and stopped at the other end of the pipe by a bar that allows product, but not the pig, to pass. The pig is returned to the launcher by using a valve to switch the direction of the compressed air. A window at either end of the pipe allows the pig to be seen by the operator. The pig is used between each batch, with additional system rinses being carried out when colour or flavour cross-contamination can occur. Occasional CIP cleans, e.g. using caustic, are used for hygiene reasons.

An innovative method using ice slurry has been rolled out with significant environmental and productivity benefits. This method involves using crushed pumpable ice as a semi-solid object to clean pipes. Rather than flushing food pipes and tanks with liquid water (prior to the use of detergents such as caustic soda), the ice slurry is driven through the system which is far more efficient at mechanically recovering residual product [107, COM 2017].

Achieved environmental benefits

Reduced product losses during batch changeovers and cleaning; reduced water consumption for cleaning and a lower quantity of waste water that is also less contaminated.

Environmental performance and operational data

With the application of this technique in an example juice installation (#153), significant reductions in water consumption for cleaning and subsequent waste water production have been achieved.

An example jam installation normally makes jam for bulk sale in 2.5-tonne batches [27, Envirowise (UK) 2000]. Before the pigging system was introduced, the whole system rinse involved sucking cleaning water, under vacuum, through the pipes between the pulping and evaporator vessels and the kettles, and then using the jam pump to pump the cleaning water through the pipe run to the tanker bay. As the jam pump was not designed to pump water, each

flush took some time. A large amount of water (5.4 m³/clean) was also used, typically twice a day. Saleable product left in the pipe was pushed out by the flush water to the drain. The site waste water thus had high TSS and COD emission levels.

Jam used to be wasted between batches on the bulk line. Following installation of the pigging system, there was an increased batch yield of jam. This resulted in some 173 tonnes of saleable product being recovered annually. The amount of mains water used to flush the bulk pipeline fell from 2 020 m³/year to 310 m³/year. Waste water volumes from the bulk line decreased by the same amount. The reduction in average COD emission levels for the site waste water fell from around a peak of 25 000 mg/l to around 5 000 mg/l, meaning that unit costs fell by over 76 %, from EUR 12/m³ to EUR 2.83/m³. Further economic information is given in Table 2.44.

The pigging system required virtually no maintenance during the first year and no new pigs were needed. Due to wear and tear of the pigs, the company expect to replace a maximum of two each year. Energy consumption fell by around 680 kWh/year because the compressed air mechanism required less energy than the old pumping arrangements.

Line cleaning takes slightly less time with the pigging system than with the old system.

Cross-media effects

No information provided.

Technical considerations relevant to applicability

Applicable where viscous materials are transferred by pipeline, e.g. juices or dairy products.

Economics

An investment cost of EUR 130 000 was reported, with annual savings of EUR 66 000 (due to less waste being produced) [193, TWG 2015].

The annual costs and savings associated with the use of pigging in the example jam-making installation are shown in Table 2.44.

Table 2.44: Environmental benefits and associated cost reduction using pigging systems

Item	Savings	Annual savings (EUR)		Annual costs (EUR)
Reduced waste water COD and volume	76 %	167 000	-	-
Recovered product	173 t/yr	217 000	-	-
Reduced water use	1 710 m ³ /yr	2 000	-	-
Reduced energy consumption	-	48	-	-
Gulley cleaning, etc.	-	-	-	6 200
Replacement pigs (2/yr)	-	-	-	180
Total	-	386 048	-	6 380
Net cost savings	-	-	379 668	-
Total capital cost	-	-	30 800	-
Payback period	-	-	4.2 weeks	-

Source: [27, Envirowise (UK) 2000]

Driving force for implementation

Recovery of valuable product and reduced water and waste water treatment costs.

Example plants

Widely used in the FDM sector [193, TWG 2015].

Reference literature

[1, CIAA 2002], [27, Envirowise (UK) 2000], [107, COM 2017], [193, TWG 2015]

2.3.3.2.3 High-pressure cleaning

Description

Spraying of water onto the surface to be cleaned at pressures ranging from 15 bar to 150 bar.

Technical description

In high-pressure cleaning, water is sprayed onto the surface to be cleaned at pressures ranging from 15 bar, which is considered to be low pressure, up to 150 bar, which is considered to be high pressure. A pressure of about 40–65 bar has also been described as high.

Mobile pressure cleaning machines require longer downtimes than those supplied from a ring main. Diesel-operated pressure cleaners emit fumes, which make them unsuitable for use inside FDM installations. Electrically operated pressure cleaners require additional operator safety precautions, including residual devices and high maintenance. Mobile machines reportedly also use more water.

Cleaning agents are injected into the water, at moderate temperatures of up to 60 °C. An important part of the cleaning action is due to mechanical effects. Pressure cleaning reduces water and chemical consumption compared with mains hoses. It is important, however, that a pressure that is both safe and efficient is used. There is concern in the food industry about the hygiene implications of over-splash and aerosols associated with the use of high-pressure hoses.

High- and medium-pressure cleaners have the following advantages compared with low-pressure cleaners, i.e. water use is lower due to the mechanical cleaning action of the water jet; chemical use is lower because heavy soiling is removed by the action of the water jet and the reduction in water volume means that there is less of a breeding ground for bacteria. However, there can be concerns about the increased aerosol risks with higher water pressures.

Research has shown that even low-pressure systems can cause a significant level of aerosol above the height of 1 metre and should not, therefore, be used during production periods in hygiene-sensitive areas. Dry clean-as-you-go systems can be used and these not only reduce water consumption and optimise waste disposal, but reduce the risks of slipping accidents. Outside of production periods, both high- and low-pressure systems can be used safely, but, because of its better efficiency, a high-pressure system is more cost-effective. High-pressure cleaning is reported to be fast, easy to use, efficient and cost-effective.

Achieved environmental benefits

Reduced water and chemical consumption, compared to traditional hoses and to low-pressure high-volume pressure cleaning.

Environmental performance and operational data

Ring mains have the advantage that they are always available for use. When using high-pressure cleaning, it is important that the correct balance is achieved between the pressure; the water volume where the water is sprayed; the water temperature and chemical dosing for each particular application. Inadequate pressure may result in poor cleaning and excessive pressure will increase the risk of damage to surfaces and equipment and even of injury to people.

Cross-media effects

No information provided.

Technical considerations relevant to applicability

Widely applicable in the FDM sector.

Economics

The cost savings, in steam, water and waste water, of high-pressure low-volume systems compared with low-pressure high-volume systems are reported to be around 85 %. There are also reduced costs associated with reduced consumption of chemicals.

Driving force for implementation

Reduced water and energy costs.

Example plants

Widely applied in the FDM sector.

Reference literature

[9, Envirowise (UK) 1998]

2.3.3.2.4 Optimisation of chemical dosing and water use in cleaning-in-place

Description

Optimising the design of CIP and measuring turbidity, conductivity, temperature and/or pH to dose hot water and chemicals in optimised quantities.

Technical description

Design and operational features which increase the efficiency of the CIP system include:

- using a turbidity or conductivity detector to optimise both the recovery of material/product from water and the reuse of cleaning water during pre-rinsing (see Sections 2.3.1.5 and 2.3.1.6);
- measuring pH to optimise chemical consumption.

Additional features to optimise CIP include the following:

- Dry product removal before the start of the wet cleaning cycle by, for example, gravity draining, pigging (see Section 2.3.3.2.2) or using compressed air.
- Pre-rinsing using small quantities of water, which, in some circumstances, may be combined with either returning the pre-rinse water to the process for reuse or recovering it for disposal.
- Internal recycling of water and chemicals.
- Water-efficient spray devices.
- Correct selection of CIP detergents.
- Collection and reuse of CIP detergents: instead of discharging to waste water after each CIP, the detergents are collected in tanks to be reused; new detergent is fed continuously until the correct concentration is reached.
- Regeneration of caustic soda used in CIP. The pipes and tanks are flushed through with hot alkali as a first step resulting in a liquid very high in organic matter. The used caustic soda is then passed through a process in which a clay-based reagent is used to separate the alkali from the solids which forms a sludge.

It is common practice for the final rinse water to be reused, either for pre-rinsing, intermediate rinsing or the preparation of cleaning solutions. The aim of the final rinse is to remove the last traces of cleaning solutions from the cleaned equipment. Clean water is used and the rinsing water, which returns to the central CIP unit, is clean enough to be reused, instead of being discharged to the drain. The recovery of the final rinsing water requires a connection from the CIP return pipe to the pre-rinsing tank. A conductivity transmitter is used to divert the water, e.g. to the pre-rinsing tank.

An example of a CIP system is shown in Figure 2.12.

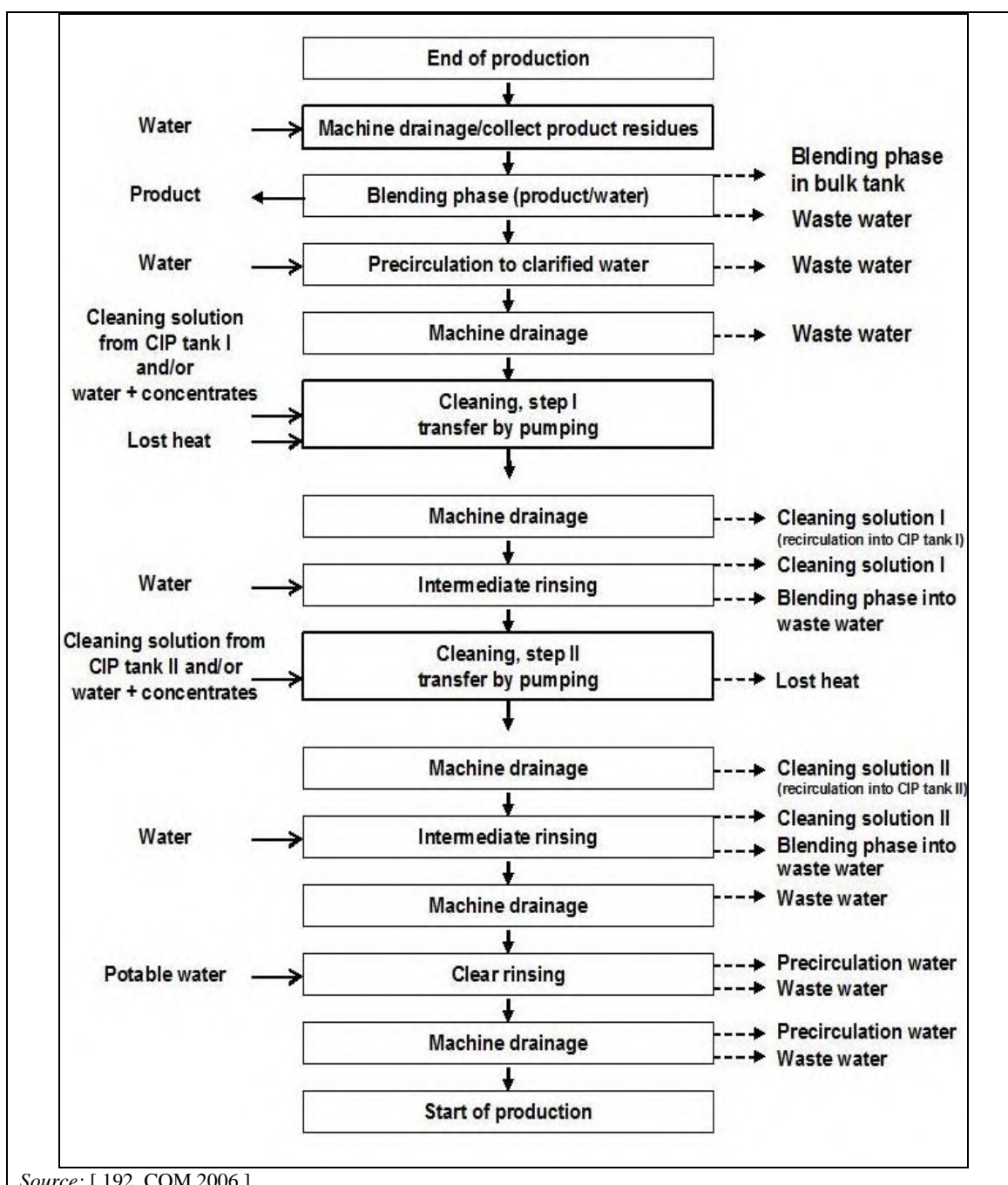

Source: [192, COM 2006]

Figure 2.12: Flow sheet of a cleaning-in-place system

It is reported that parallel or serial cleaning of tanks and parallel cleaning of pipe systems need to be avoided. Both parallel and serial cleaning of tanks result in excessive mixing of pre-rinse and cleaning solution, and cleaning solution and final rinse. This limits the reuse of cleaning solution and energy. In a parallel configuration, it can be difficult to achieve the required distribution of the flow through more than one tank and the CIP return from the tanks needs a different residence time. When switching from pre-rinse to cleaning solution or from cleaning solution to final rinse this results in a long mixing zone. In a serial configuration, the content of the piping between tanks I and II will result in a long mixing zone as well if the content is not drained. When the cleaning solution arrives in tank I (drained), the pre-rinse content of the piping may become mixed with cleaning solution in tank II (drained before).

Achieved environmental benefits

A reduction in the consumption of hot water, cleaning agents and the energy needed to heat the water is achievable. It is possible to maximise product recovery and reuse water and chemicals within the system. There is a subsequent reduction in the amount of waste water generated.

Environmental performance and operational data

Optimising the CIP systems can, for example, minimise the quantity of the cleaning and disinfection agents used, by recirculating cleaning solutions. Some losses will still occur with contaminated water and solutions; therefore, they still need to be recharged. For example, when the particulate content of cleaning solution reaches a specific level it will need to be disposed of. An additional effect of recirculating the solutions is that a partial recuperation of the thermal energy is possible.

In an example installation in Germany, the cleaning solution, i.e. 2 % caustic soda, is reused during the five or six working days of the week. The solution can be used for longer, e.g. weeks, if a storage tank is installed.

Figure 2.13 shows the CIP system for a bottling process in a brewery.

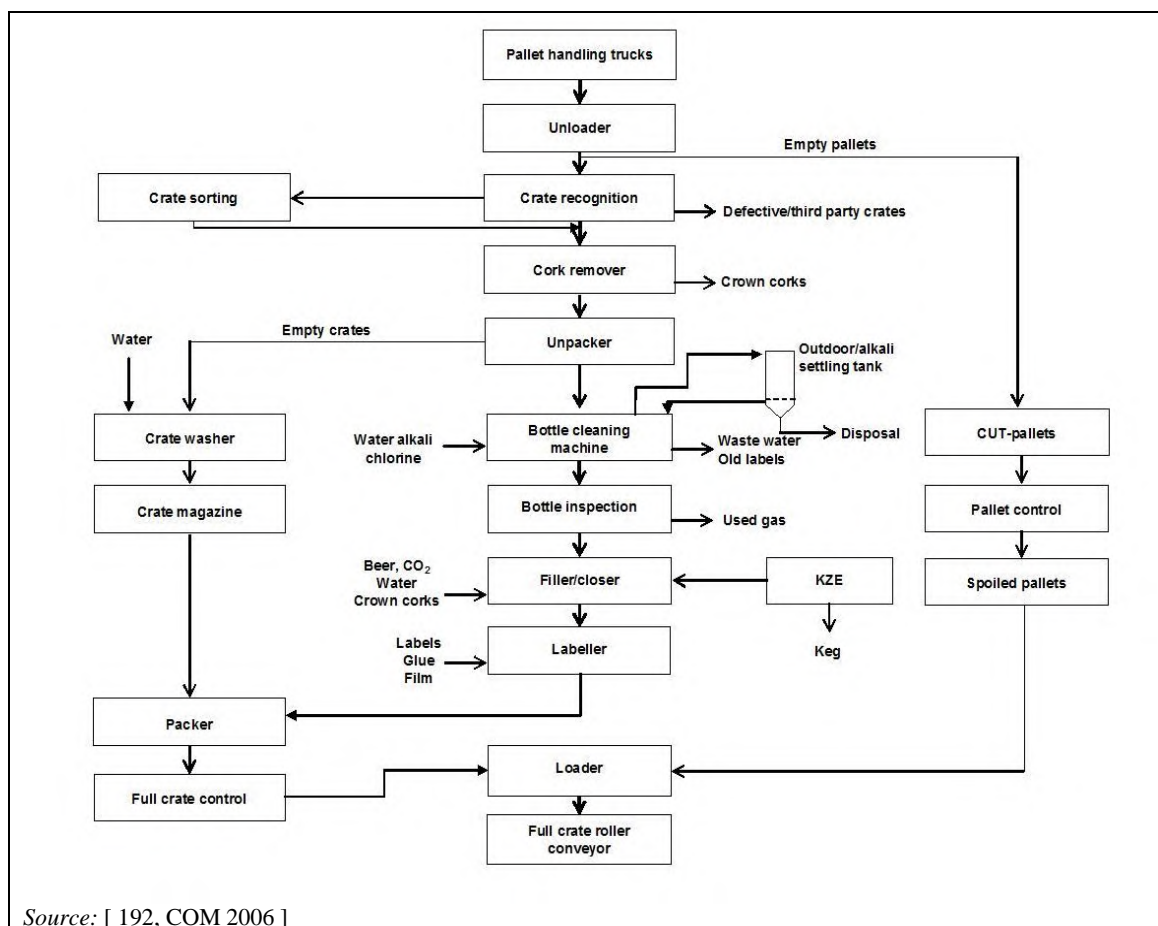

Source: [192, COM 2006]

Figure 2.13: A CIP system for the bottling process in a brewery

Turbidity meters can be used in CIP for phase changes between product and water. The conductivity of milk products and cream is very similar to that of water. It is easier to control phase changes between milk products and water with turbidity meters. This will reduce the amount of product residues in the waste water.

Conductivity meters are used to control the phase changes between lye and water and between acid and water. Therefore it is easier to control what should go back to the cleaning solution tanks, what should go to waste water and what should be reused as rinsing water. In this way, the amount of water and the amount of cleaning solution discharged as waste water are reduced.

The use of flow meters in combination with preset volumes also reduces the amount of water needed.

Within a six-year implementation of CIP optimisation (collection and reuse of detergents) in a dairy installation (#127), consumption of water decreased to 55 % and consumption of detergents decreased to 34 %. In a brewery installation (#400), the application of one phase of CIP has resulted in a 30 % reduction of water consumption for cleaning [193, TWG 2015].

Cross-media effects

Possible energy use associated with pumping the water and cleaning agents.

Technical considerations relevant to applicability

Applicable to closed/sealed equipment through which liquids can be circulated, including for example pipes and vessels. Incorporation of a CIP system can be considered at the equipment design stage and installed by the manufacturer. Retrofitting a CIP system may be possible but is potentially more difficult and expensive.

For large installations with highly branched pipework, a centralised CIP system may not be appropriate. Often, the distances are too long and this leads to considerable losses of heat, detergents and water, as well as excessive pumping capacities. In such cases, several small CIP systems can be used. These can be supplied with the necessary cleaning solutions from the centralised CIP system, via a closed pipeline.

For some applications, such as some small or rarely used installations or where the cleaning solution becomes highly polluted, such as UHT installations, membrane separation plants, and the preliminary cleaning of evaporators and spray dryers, single-use systems are used. In these systems, cleaning agents are not reused because they may impede the cleaning effect in other installations.

Economics

The capital cost can be high but annual savings due to reduced hot water and chemical consumption are achieved.

Driving force for implementation

- Reduced costs of water, energy and chemicals.
- Automation and ease of operation.

Example plants

CIP is widely used in the FDM sector. For example, an online detection of transition points between the product and the water phases is implemented for the recovery of product from CIP in a dairy installation (#341) [193, TWG 2015].

Reference literature

[1, CIAA 2002], [5, German Dairy Association 1999], [21, Nordic Council of Ministers 2001], [107, COM 2017], [130, Portugal-FIPA 2003], [134, German Dairy Association 1997], [144, CIAA-EDA 2003], [192, COM 2006], [193, TWG 2015]

2.3.3.2.5 Low-pressure foam and/or gel cleaning

Description

Use of low-pressure foam and/or gel instead of water to clean walls, floors and/or equipment surfaces.

Technical description

Low-pressure foam cleaning can be used instead of traditional manual cleaning with water hoses, brushes and manually dosed detergents. It can be used to clean walls, floors and equipment surfaces. A foam cleaner, such as an alkaline solution, is sprayed on the surface to be cleaned. The foam adheres to the surface. It is left for about 10–20 minutes and is then rinsed away with water.

Low-pressure foam cleaning can either use a centralised ring main or decentralised individual units. Centralised systems supply pre-mixed cleaning solutions and pressurised water from a central unit and during cleaning they automatically change between foam spreading and rinsing.

Achieved environmental benefits

Reduced water, chemical and energy consumption compared to the use of traditional water hoses, brushes and manually dosed detergents.

Environmental performance and operational data

A dairy in Denmark, producing 25 000 tonnes of cheese per year, has a centralised system consisting of about 50 satellite units, located in the different process areas. The water consumption has been calculated to be 40 % of the corresponding consumption for traditional manual cleaning. The foam cleaning system reportedly uses cold water at 10 °C, whereas manual cleaning with water hoses requires water of at least 40 °C. The calculated savings in this case are 19 800 m³ water/year and 1 160 MWh/year.

Reported advantages of using foams include increased contact time with soiled surfaces, which allows improved cleaning results to be achieved, even though less aggressive chemicals are used. The chemical constituents soften soiling, resulting in improved rinsing efficiency and cleaning. It is easy to see where foams have been applied and they are very easy to rinse, so less water is used. Labour costs are also reduced because, compared with traditional methods, cleaning takes less time. Due to less aggressive chemicals being used, there is reduced wear and tear on machinery and reduced risk to the operator. A potential disadvantage of using foams is that their bulky nature can cause them to shear from surfaces under their own weight, so reducing the contact time.

Gels are typically used for cleaning walls, ceilings, floors, equipment and containers. The chemical is sprayed onto the surface to be cleaned. Cleaning with gels provides a longer contact time than foams, between the soiling and active detergent, because of the tenacious nature of gels with surfaces and there is greater accessibility to crevices as access is not inhibited by air bubbles. However, gels are transparent and difficult to see and may be inconsistent at high temperatures.

Reported advantages of using gels include increased contact time with soiled surfaces, which allows improved cleaning results to be achieved, even though less aggressive chemicals are used. The chemical constituents soften soiling, resulting in improved rinsing efficiency and cleaning. As gels are very easy to rinse, less water is used. Labour costs are also reduced because, compared with traditional methods, cleaning takes less time. Due to less aggressive chemicals being used, there is reduced wear and tear on machinery and reduced risk to the operator.

This technique is of little relevance when cleaning is not frequent, e.g. in the sugar sector.

Cross-media effects

No information provided.

Technical considerations relevant to applicability

Applicable in new and existing installations, for cleaning floors, walls, vessels, containers, open equipment and conveyors.

Economics

The investment cost of the foam cleaning system in an example cheese installation in Denmark (reported in 2000) was about EUR 188 000, with a payback time of 3.2 years.

Driving force for implementation

Better cleaning and the elimination of problems associated with high-pressure cleaning, e.g. spreading of aerosols containing dirt particles and bacteria.

Example plant

At least one cheese installation in Denmark.

Reference literature

[9, Envirowise (UK) 1998], [21, Nordic Council of Ministers 2001]

2.3.3.2.6 Optimised design and construction of equipment and process areas**Description**

The equipment and process areas are designed and constructed in a way that facilitates cleaning. When optimising the design and construction, hygiene requirements are taken into account.

Technical description

The hygienic design is a set of design and construction criteria that improve the cleanability of equipment and facilities, by avoiding critical points and dead zones where the product may be retained and cannot be removed properly using standard sanitation (cleaning and/or disinfection). The prefix 'eco' refers to additional design criteria intended to reduce the environmental impact during sanitation (i.e. spillage collection, reduction of pipelines, reuse of cleaning water in closed loops, etc.)

The main goal of hygienic design of equipment and facilities is hygiene, but it is also related to the reduction of the environmental impact of cleaning and disinfecting operations, requiring a lower input of water, energy and chemicals to achieve the same level of hygiene. In other words, from the hygienic point of view, equipment and premises are hygienically designed and constructed if they minimise the risk of contamination of food being processed.

From the environmental point of view, equipment and premises hygienically designed and constructed reduce the environmental impact of their sanitation. Eco-hygienic design of equipment and installations is presented as a preventive technique to reduce the environmental impact of sanitation of food production equipment while maintaining the hygienic results of sanitation.

At the global level, there are two recognised groups working on hygienic design criteria and standards:

- The European Hygienic Engineering & Design Group (EHEDG) has published several guidelines for hygienic design criteria that have become a reference for both equipment manufacturers and the food industry. These guidelines are online and are regularly updated and complemented by new documents in various languages.
- 3-A SSI is an independent US corporation dedicated to education and the mission to promote food safety through hygienic equipment design in the food, beverage and pharmaceutical industries (<http://www.techstreet.com/3a>).

Achieved environmental benefits

Reduction in consumption of water, energy and chemicals.

Environmental performance and operational data

The data presented in this section come from the demonstration trials developed in the ECODHYBAT project in two Spanish companies: Calidad Pascual (dairy products) and Pescanova (sea product processing). Table 2.45 shows the values of reduction of water and energy consumed during sanitation of hygienically designed equipment compared to the consumption levels during sanitation of conventional equipment.

Table 2.45: Reduction in water and energy consumption during sanitation of hygienically designed equipment compared to conventional equipment

Indicator	Calidad Pascual (dairy products)	Pescanova (sea product processing)
Reduction of direct water consumption in sanitation	41 %	33 %
Reduction of direct energy consumption in sanitation	14 %	33 %

Source: [113, AINIA 2016]

The sanitation of 14 pieces of food industry equipment designed according to eco-hygienic design criteria were compared one by one to the sanitation of equivalent conventional equipment. The results on water savings in these demonstration trials are shown in Table 2.46.

The industrial equipment to be evaluated was artificially soiled using a soiling solution composed of a mixture of whole milk, fluorescein, ethanol and gluing additive. The performance of the sanitation in both hygienically designed and conventionally designed equipment was determined by measuring the fluorescein concentration. The evolution of the fluorescein concentration over time allowed the measurement at the moment when the equipment was cleaned, and the comparison of the consumption of water and energy between hygienically designed and conventionally designed equipment.

Table 2.46: Water savings in sanitation of hygienically designed versus conventional equipment

Plant	Range of water savings (%)	Water savings average (%)
Calidad Pascual (dairy products)	9–75	41
Pescanova (sea product processing)	0–96	33

Source: [113, AINIA 2016]

Cross-media effects

The construction phase of some eco-hygienically designed equipment could potentially entail an increase in material, energy or water use compared to construction of conventional equipment (i.e. extra polishing in order to reduce the roughness of the surface). However, any extra consumption required would be clearly negligible in comparison to the consumption of the near daily sanitation over the total life cycle of food processing equipment (lifetime 10–20 years).

Technical considerations relevant to applicability

No technical restrictions in relation to the applicability of this technique.

Economics

In the majority of cases, the increase in the market price of eco-hygienic certified equipment (with EHEDG certification) compared to their conventional equivalents is below < 5 % (data from a survey of machinery production companies carried out by the ECODHYBAT project).

Related information is shown in Table 2.47.

Table 2.47: Market price of eco-hygienic certified equipment

Equipment	Price, conventional (EUR)	Price, eco-hygienic certified (EUR)	Price increase (%)
Pump HCP 40-150	1 670	1 690	1.20
Ball valve DN 2'	198	208	5.05
Throttle valve - casting GGG40 + PTFE 2"	4.75–241.91	10–300	24–110
Single-seated valve–Aseptic version	511–1902	530–1 930	1.5–3.9
Flexible tube (EUR/m)	7–27	11–35	30–57
2" metal connection with clamp	5	14	180
Sensor VEGABAR 64	1 580	1 619	2.5
Electromagnetic flow meter	670–775	69–785	1.3–3.1
<i>Source: [113, AINIA 2016]</i>			

Driving force for implementation

Reduction of costs associated with savings in water and energy consumption.

Example plants

Calidad Pascual (dairy products) and Pescanova (sea product processing) in Spain.

Reference literature

[113, AINIA 2016]

2.3.3.2.7 Cleaning of equipment as soon as possible

Description

Cleaning is applied as soon as possible after use of equipment to prevent wastes hardening.

Technical description

For additional information consult the Sectoral Reference Document on Best Environmental Management Practices for the food and beverage manufacturing sector [107, COM 2017].

Achieved environmental benefits

Reduced water consumption and waste water pollution.

Environmental performance and operational data

No information provided.

Cross-media effects

No information provided.

Technical considerations relevant to applicability

Applicable to all installations where manual cleaning is applied.

Economics

No information provided.

Driving force for implementation

Reduced cost of water and waste water treatment.

Example plants

This technique is widely applied in the FDM sector.

Reference literature

[107, COM 2017]

2.3.3.2.8 Fitting of cleaning hoses with hand-operated triggers

Description

Fitting of cleaning hoses with hand-operated triggers.

Technical description

Trigger control shut-offs can be fitted to cleaning hoses with no other modification, if a water heater is used to provide hot water. If a steam- and water-blending valve is used to provide hot water, it is necessary to install check valves to prevent steam or water from entering the wrong line. Automatic shut-off valves are often sold with nozzles attached. Nozzles increase the water impact and decrease the water flow rate.

Achieved environmental benefits

Reduced water and energy consumption.

Environmental performance and operational data

In an example installation, the energy saved was calculated for running a hose that had been fitted with an automatic shut-off valve and nozzle, using water at a temperature of 71 °C. The flow rate before installation was 76 l/min and after installation was 57 l/min. The time the hose was running was 8 h/day before installation and 4 h/day afterwards. For a water cost of USD 21/m³, an annual water cost saving of USD 4 987 (costs in 2000) was calculated. An annual energy saving of 919 GJ has also been calculated.

Cross-media effects

No information provided.

Technical considerations relevant to applicability

Applicable to all FDM installations.

Economics

If nozzles are installed without automatic shut-offs, the equipment costs are less than USD 10. An automatic trigger-controlled shut-off with a nozzle costs approximately USD 90. (Costs in 2000.) The payback is reported to be immediate.

Driving force for implementation

Reduced water and energy costs.

Example plants

Widely applied in the FDM sector.

Reference literature

[1, CIAA 2002], [133, Ockerman et al. 2000]

2.3.3.3 Techniques related to cooling/freezing

2.3.3.3.1 Closed-circuit cooling

See also Section 2.3.3.1.1.

Description

Recirculation of cooling water via a cooling tower or a cooler connected to a central refrigeration plant.

Technical description

The water is recirculated via a cooling tower or a cooler connected to a central refrigeration plant, i.e. it is rechilled and returned to the equipment being cooled. If there is a need to prevent algae or bacterial growth, chemicals may be added to the recirculated water. Otherwise, the cooling water can be reused for cleaning purposes.

Achieved environmental benefits

Reduced water consumption and reduced waste water treatment.

Environmental performance and operational data

It is reported that closed-circuit cooling can save 80 % of water consumption, compared to an open system. This may be significant in areas where water is not readily available. Once-through cooling water which does not contact the FDM materials will not entrain contaminants and may be considered for direct discharge to a receiving water body; however, it will carry a thermal load. Passing once-through uncontaminated cooling water through a WWTP both increases energy consumption and causes dilution, without decreasing the overall load, so direct discharge is advantageous.

In an example brewery with a capacity of 500 000 hl/year, a closed-circuit cooling system was introduced in a tunnel pasteurisation unit to replace an open system which cooled using fresh water. The reduction in water consumption was estimated to be 50 000 m³/year.

For fermenter cooling, closed-circuit cooling using a chiller and a recirculation pump is reported to result in improved cooling.

In sugar production, cooling water is used on site for electricity-generating turbines. Typically, cooling water will have been abstracted from a river and will pass around a turbine once before it is discharged back to the river.

Cross-media effects

Energy may be consumed to cool the cooling water. It may be possible to recover some of this heat.

In recirculating cooling tower systems, the cooling water is recycled constantly through a cooling tower. However, running the water over the cooling tower maintains a high dissolved oxygen level which can cause corrosion within the system, and evaporation of water at the tower can cause the build-up of suspended solids. The recirculating water may, therefore, require treatment to prevent corrosion and some of the water needs to be discharged periodically to prevent build-up of excess dissolved solids. Precautions also need to be taken to control the conditions for growth of *Legionella* bacteria, which may make the spray from cooling towers a possible source of legionnaires' disease. Closed-circuit systems minimise corrosion and there is no build-up of dissolved solids.

If a large water source, such as a large-volume-flow river is available, then the cross-media effects associated with closed-circuit cooling may be greater. If the river can provide the volume required and accept the thermal load without significant harm to aquatic life or without interfering with other users of receiving surface water and the water does not become contaminated then once-through cooling may be a better environmental option. Once-through

cooling water will also require energy to pump it from its source and out of the installation. If care is not taken to prevent leaks from the system being cooled, then contaminated water may be discharged.

Technical considerations relevant to applicability

Generally, there are no technical restrictions to the applicability of this technique.

Economics

In the brewery example reported above, the investment cost of the installation of the cooling tower and other necessary equipment was USD 45 000 (before 1996) and the payback period was approximately a year.

Driving force for implementation

Reduced water consumption and subsequently reduced waste water and the associated financial savings.

Example plants

Applied in dairies, breweries, soft drinks manufacturing and sugar production from sugar beet.

Reference literature

[8, Environment Agency of England and Wales 2000], [11, Envirowise (UK) 1998], [29, Danbrew Ltd 1996], [128, CIAA-Federalimentare 2003], [129, Italy M. Frey 2003]

2.3.3.3.2 Recirculation of cooling water after electrochemical treatment

See also Section 2.3.3.1.1.

Description

Recirculation of water from the cooling tower pond through a vessel containing electrodes made from a combination of metal oxides which act as anode where oxidising ions are generated from water.

Technical description

The technique involves recirculation of water from the cooling tower pond through a vessel containing electrodes made from a combination of metal oxides which act as anode where oxidising ions are generated from water. Furthermore, the vessel wall acts as cathode, reaching a pH of 13 which causes the precipitation of calcium salts on the vessel wall, preventing the concentration of salts in the tower pond and, therefore, preventing the need to purge water from the pond. Periodically, in a programmed way, the salty precipitate on the vessel wall is washed off and drained. By applying direct current voltage to electrodes in the chambers, OH⁻ ions are produced by partial electrolysis of the water. The addition of OH⁻ ions promotes a scale formation with the excess of Ca⁺² and CO₃⁻² ions in the chambers.

Achieved environmental benefits

Reduced water consumption and avoidance of the use of chemicals.

Environmental performance and operational data

In an example brewery (#157), 80 % of the cooling towers' water consumption is reduced, and also 100 % of the chemical consumption, avoiding continuous chemical treatment. The maintenance and cleaning of equipment takes about half an hour per month.

This technique is generally efficient provided the characteristics of the water supply network do not fluctuate continuously.

Cross-media effects

No information provided.

Technical considerations relevant to applicability

No information provided.

Economics

An investment cost of EUR 40 000 and annual operating cost of EUR 2 400 have been reported, with annual savings of EUR 28 000 (for nine pieces of equipment for treating 10 evaporating condensers).

Driving force for implementation

Limitations on the use of chemicals in operating licences.

Example plants

At least one brewery installation (#157).

Reference literature

[193, TWG 2015]

2.3.3.4 Techniques related to bottling**2.3.3.4.1 Dry disinfection****Description**

Disinfection of PET packaging without the use of water, e.g. with compressed air, ionised air or nitrogen peroxide.

Technical description

The classic disinfection technique uses water and peracetic acid to rinse and disinfect the bottle. Even if the disinfection solution is reused several times, this technique generates a huge volume of waste water. With dry disinfection no water is used; instead compressed air, ionised air or nitrogen peroxide is directly injected into the preforms before they are heated, it then vaporises during the heating and the blowing, producing an aseptic empty bottle. The bottles are filled directly and closed without using water.

Achieved environmental benefits

Reduced energy and water consumption.

Environmental performance and operational data

In a soft drinks installation (#279), the use of the dry bottling technology contributed to an increase in the total water recycled in the installation.

Cross-media effects

Consumption of air or nitrogen peroxide.

Technical considerations relevant to applicability

Generally, there are no technical restrictions to the applicability of this technique.

Economics

An investment cost of EUR 6 million has been reported for a soft drink and nectar juice installation with a permitted production capacity of 1 000 tonnes/day.

Driving force for implementation

Reduction in energy costs and water consumption.

Example plants

Installation # 279.

Reference literature

[193, TWG 2015]

2.3.3.5 Techniques related to steam systems

2.3.3.5.1 Maximisation of condensate return

See also Section 2.3.3.1.1.

Description

Recovered condensate can be reused as feed to the boiler, heated water, for other equipment or cleaning other installations.

Technical description

In this technique, water and heat which is contained in discharge condensate is taken advantage of. This recovered condensate can be reused as feed to the boiler, heated water, for other equipment or cleaning other installations. A condensate recovery unit is a vessel which receives condensate from all practical points where condensate is produced. The vessel stores the condensate and mixes it with fresh make-up water prior to it being used as boiler feed water.

If hot condensate is not returned to the boiler it has to be replaced by treated cold make-up water. The additional make-up water also adds to water treatment costs. Instead of routinely discharging condensate to the WWTP because of the risk of contamination, the condensate can be collected in an intermediate tank and analysed to detect the presence of any contaminant. This also leads to savings in the use of chemicals for the treatment of boiler feed water. Additionally or alternatively, if the condensate cannot be returned to the boiler due to contamination, heat can be recovered from the contaminated condensate before it is used for lower-grade cleaning activities, e.g. yard cleaning. Pollution can be detected by different devices (e.g. turbidimeter). In general, the temperature of recovery condensates is about 100 °C to 180 °C. Mechanical pumps can be used in all situations in which the condensates generated do not have enough pressure to be returned to the feeding tank.

The energy in any steam used for direct injection to the process may be considered to be fully utilised.

Achieved environmental benefits

Reduced energy and water consumption and reduced waste water generation. Reduced consumption of boiler feed water treatment chemicals.

Environmental performance and operational data

If hot condensate is not returned to the boiler, it has to be replaced by treated cold make-up water and wastes some 20 % of the energy absorbed in the generation of the steam from which the condensate is derived. This may be the greatest single energy loss in steam use.

In an example dairy installation (#311), high-pressure steam condensation water, drained by condensation traps mounted before every user pressure reduction system, is routed back into the boilers' feed water tank. The total annual water demand is reduced by 3 %. In an example sugar manufacturing installation (#413), condensate generated during the campaign is stored on site and reused during non-operational periods to replace borehole-extracted water, where borehole-extracted water quality is not required [193, TWG 2015].

Technical considerations relevant to applicability

Applicable where steam is produced in a boiler.

Economics

An investment cost of EUR 50 000 (EUR 45 000 for the pipeline return system and EUR 5 000 for the project and design) and payback periods of 1–4 years have been reported.

Driving force for implementation

Reduced energy consumption and associated costs.

Example plants

Used in various FDM sectors [193, TWG 2015].

Reference literature

[39, Environment Agency of England and Wales 2001], [193, TWG 2015]

2.3.4 Techniques to avoid the use of harmful substances**2.3.4.1 Proper selection of cleaning chemicals and/or disinfectants****Description**

Avoidance or minimisation of the use of cleaning chemicals and/or disinfectants that are harmful to the aquatic environment, in particular priority substances considered under the Water Framework Directive. When selecting the substances, hygiene and food safety requirements are taken into account.

Technical description

Chemicals such as chlorine, quaternary ammonium compounds, bromine- or iodine-based products are routinely used to maintain the hygiene of food manufacturing sites. However, these are often potentially hazardous in combination with organic residues. Moreover, to work safely and effectively, such chemicals typically require large volumes of water and often high temperatures. Then, when cleaning is complete, further treatment with a significant associated environmental impact is often needed to clean up any effluent.

Avoiding or minimising the production of harmful residues can include the following measures:

- use of less harmful cleaning chemicals (e.g. ozone);
- reduce the use of cleaning chemicals (e.g. EDTA, halogenated biocides, acids).

Ozone (O₃) in water solution can destroy the cell membrane of pathogens by oxidising the phospholipids and lipoproteins and has the advantage of itself quickly breaking down into harmless oxygen. Ozone is effective against a wide range of microbes including bacteria, yeasts, moulds, viruses and spores. The incorporation of ozone-rich water in CIP and other cleaning processes has the advantage over traditional disinfectants that no residues are left and the ozone is applied cold. This reduces the volume of water necessary to rinse detergents from the plant and the energy use associated with heating the water. Ozone can also be used in dry settings.

Using products with an EU Ecolabel is a voluntary commitment to a sustainable environment. From raw materials to production, packaging, distribution and disposal, EU Ecolabel products have been evaluated by independent experts to ensure that they meet the criteria that reduce their environmental impact. Detergents that meet the criteria of the European Ecolabel are readily biodegradable and are not toxic to the environment.

Achieved environmental benefits

Reduction in consumption of cleaning agents and detergents.

Environmental performance and operational data

No information provided.

Cross-media effects

No information provided.

Technical considerations relevant to applicability

No technical restrictions in relation to the applicability of this technique.

Economics

No information provided.

Driving force for implementation

No information provided.

Example plants

This technique is implemented in multiple FDM installations [193, TWG 2015].

Reference literature

[107, COM 2017], [193, TWG 2015]

2.3.4.2 Reuse of cleaning chemicals in cleaning-in-place

Collection and reuse of cleaning chemicals in cleaning-in-place (CIP). When reusing cleaning chemicals, hygiene and food safety requirements are taken into account.

See also Section 2.3.3.2.4.

2.3.4.3 Dry cleaning

See Section 2.3.3.2.1.

2.3.4.4 Optimised design and construction of equipment and process areas

See Section 2.3.3.2.6.

2.3.4.5 Use of refrigerants without ozone depletion potential and with low global warming potential

Description

Prevention of emissions of substances that deplete the ozone layer or have a high global warming potential by using alternative refrigerants, such as water, carbon dioxide or ammonia.

Technical description

Refrigerants are widely used in the FDM sector in cooling, refrigeration and freezing operations. The interaction of halogen refrigerants with ozone in the air has resulted in the progressive prohibition of the placing on the market and use of ozone-depleting substances and of products and equipment containing those substances. These compounds are being substituted by other refrigerants such as carbon dioxide, ammonia, glycol or, in some cases, by chilled water.

The leakage rate for industrial HFC refrigeration systems has been estimated at around 8 %, compared to > 20 % for HCFC-containing equipment. The overall consumption of HFC refrigerants for the first fill of new equipment and the refill in existing equipment is estimated to grow significantly in the future [25, COM 2011].

Hydrochlorofluorocarbons (HCFCs), hydrofluorocarbons (HFCs), chlorine and ammonia are frequently used if the temperatures are below -10 °C. HCFCs have the disadvantage of depleting the ozone layer when released to the atmosphere. They also show considerable GWP. The use of HCFCs is generally prohibited [140, EC 2009]. HFCs have the disadvantage of possessing a much higher GWP than alternative refrigerants such as ammonia, carbon dioxide, chlorine and water. There are provisions aiming at containing, preventing and thereby reducing emissions of HFCs [137, EC 2014].

Achieved environmental benefits

Reduced risk of ozone depletion and global warming.

Cross-media effects

The risk of ammonia and glycol leaks, which can cause health and safety problems.

Environmental performance and operational data

The use of substances that deplete the ozone layer can be prevented or minimised by [35, Germany 2002]:

- using substitutes for such substances;
- when ozone-depleting substances are used, using closed-circuit systems;
- enclosing systems in buildings;
- encapsulating parts of systems;
- creating a partial vacuum in the encapsulated space and preventing leaks in systems;
- collecting the substances during waste treatment;
- using optimised waste gas purification techniques;
- proper management of the recovered substances and the waste.

Ammonia (R717) has been used for industrial refrigeration for a long time. Ammonia refrigeration systems are more costly, especially in the low-capacity range. Since the year 2000, HCFC-22 has been replaced in new equipment by the HFC refrigerant R404A, first in Europe, then in other industrialised countries. In recent years, a number of cascade systems with ammonia and CO₂ have been installed in the food industry [25, COM 2011].

For example, a Norwegian ice cream plant is using a transcritical CO₂ cooling and freezing system with heat recovery and hot gas defrost capabilities [107, COM 2017].

Economics

Substitution of refrigerants is energy-efficient for industrial cooling systems. Examples of individual abatement costs for the alternative option ammonia (R717) are given in the preparatory study for a review of Regulation (EC) No 842/2006 on certain fluorinated GHG [25, COM 2011].

For a small system with 270 kW cooling capacity at three temperature levels:

- Cost of HFC system: EUR 425 000.
- Additional cost of similar NH₃ system: EUR 132 000 (+31 %).
- Electricity consumption: 1 800 000 kWh/year.
- NH₃: -27 % electricity consumption.
- Operation cost for F-gas system: EUR 100 000 per year.

For a large system with 5 MW cooling capacity:

- Cost of HFC system: EUR 6 million.
- Additional costs for similar NH₃ system: between 0 and 20%.
- Electricity consumption: between -10 % and -30 %.
- Operating cost for the large system: EUR 1 million per year.

Driving force for implementation

There are low-impact alternatives available in the FDM sector and promoted by the Regulation (EU) No 517/2014. For some gases, e.g. HFOs (hydrofluoroolefins), there is no ban in Regulation (EU) No 517/2014 but only a reporting obligation. In addition, this Regulation's rules related to equipment aim to minimise leakage, not to prevent the use of all such gases. Moreover, the quota system refers to total tonnes of CO₂ equivalent and does not mention specific gases [137, EC 2014].

Example plants

This technique is implemented in multiple FDM installations [193, TWG 2015].

Reference literature

[25, COM 2011], [35, Germany 2002], [107, COM 2017], [137, EC 2014], [140, EC 2009], [193, TWG 2015]

2.3.5 Techniques to increase resource efficiency

2.3.5.1 Anaerobic digestion

Description

Treatment of biodegradable residues by microorganisms in the absence of oxygen, resulting in biogas and digestate. The biogas is used as a fuel, e.g. in a gas engine or in a boiler. The digestate may be used, e.g. as a soil improver.

Technical description

The treatment of biodegradable solids by anaerobic digestion is used to transform the organic matter contained in the residues into biogas (containing 70 % methane) and digestate. Anaerobic digestion is used to handle biodegradable solids very high in COD, and as a treatment process for sewage sludge after an aerobic waste water treatment. For the use of the biogas as a fuel, see Section 2.3.2.1.2.

The technique generally consists of the following steps:

- Anaerobic digestion: residues are directed to a sealed digester tank where anaerobic digestion takes place. This is a process by which microorganisms break down biodegradable material in the absence of oxygen, resulting in biogas and digestate.
- Biogas line: generated biogas is stored and at a later stage is dehumidified and used, e.g. in a cogenerator. It can also be used to produce heat, i.e. hot water in a boiler, combined electricity and heat in a CHP unit, as an alternative fuel in vehicles or as a substitute for natural gas after upgrading to biomethane. Some of the heat generated may be recycled in the FDM process.
- Separation: the digestate is separated into solid and liquid fractions by centrifugation.
- Storage of the solid fraction of the digestate: the solid fraction of the digestate is stored for agricultural purposes (landspreading).

More detailed information on the process description, feed and output streams, biogas pretreatment techniques, and characteristics of the digestate is available in the WT BREF [154, COM 2015]. A list of proven improvement techniques for anaerobic digestion of waste (e.g. micro anaerobic digestion, vertical flow dry) is described in the EC report 'Towards a better exploitation of the technical potential of waste to energy' [155, COM 2016].

Anaerobic co-digestion allows the operator to take advantage of the complementary nature of the composition of the waste. The best example is the co-digestion of manure and food wastes. The mixture of both types of waste leads to more stable processes and a considerable increase in biogas production. The co-digestion allows the integration of the exploitation of organic waste in a given geographical area. Anaerobic digestion systems commonly used for the co-digestion of agro-industrial waste are called continuous stirred tank reactors [152, AINIA 2016].

Achieved environmental benefits

Waste generation and emissions to air are reduced (biogas is used for energy to replace fossil fuels). The recovery of by-products to produce digestate for agriculture conserves and recycles nutrients and reduces waste discharge and the use of chemical fertiliser.

Environmental performance and operational data

Emissions to water from anaerobic digestion in FDM installations are not an environmental issue, given that the digestate is usually treated in the WWTP.

Anaerobic digestion of food waste is usually carried out when the total solid content is below 15 %. Water contained in food waste does not produce biogas and occupies part of the volume in the digestion tank. However, water is required for the fermentation. The volatile solid content is about 70–95 % of the total solid content. The energy output from an anaerobic digestion plant depends to a great extent on the biomethane potential of the feedstock. The maximum potential can vary from 0.15 m³ to 0.90 m³ biogas/kg of volatile solid content [152, AINIA 2016].

In a meat installation (#331), a digester was fed with around 28 000 t/year of proteins and fats recovered from the DAF step in the WWTP. The biogas produced was used to power a combustion engine to cogenerate electricity and heat, which are then used in the meat production processes. The amount of solid fraction in the digestate produced was 1 361 tonnes during six months. The reduction of waste generation was approximately 95 %.

Cross-media effects

The nitrogen content of residues is not reduced after anaerobic digestion. Further waste water treatment of liquid digestate is usually required (e.g. membrane filtration).

Technical considerations relevant to applicability

The technique may not be applicable due to the quantity and/or nature of the residues. Digesters should be fed at a constant rate to operate properly. Due to the investment costs, a digester may not be applicable to installations with low amounts of residues. The lowest amount of residue treated by a digester was 396 tonnes/year, reported by installation #133.

Economics

An investment cost of EUR 3 500 000 has been reported, including an anaerobic biodigester plant, biogas cogenerator, centrifuge and a scrubber as the abatement system. The amount of electricity produced by the biogas cogenerator in a six-month period was approximately 40 000 MWe. The amount of solid fraction of the digestate produced is about 3 500 tonnes/year. Savings of EUR 50 000/year have been reported due to the reduction of sludge considered as waste.

Driving force for implementation

Economic reasons are the main drivers for implementation, due to reduced energy consumption and waste generation.

Example plants

This technique is used in several FDM sectors [193, TWG 2015]. Example plants include #048, #133, #144, #250 and #331.

Reference literature

[2, IED Forum 2018], [91, Giner Santonja et al. 2017], [152, AINIA 2016], [154, COM 2015], [155, COM 2016], [193, TWG 2015]

2.3.5.2 Use of residues

Description

Residues are used, e.g. as animal feed.

Technical description

Numerous examples exist in the FDM sector where raw materials, partially processed foods and final products, either originally intended for human consumption or from which the part intended for human consumption has been removed, may be used as animal feed. For example, foods which are slightly outside the customer specification, or which have been over-produced, may be suitable for use as animal feed. Examples of sources of animal feed from FDM manufacturing for human consumption are shown in Table 2.48.

More information can be found in Commission Regulation (EU) No 68/2013 of January 16 2013 on the Catalogue of feed materials.

Table 2.48: Examples of sources of animal feed from FDM manufacturing for human consumption

Source of animal feed	Example industry source
Bones and fat	Meat processing (subject to hygiene regulations)
Rejected fish	Fish processing
Stalks, hulls and leaves	Fruit and vegetable processing
Fruit and vegetables, such as peel, cores and cutting residues	Fruit and vegetable processing
Apple and tomato pomace and citrus pulp pellets, without or after treatment	Fruit and vegetable processing
Crude olive cake (also called pomace)	From the first pressing of olives
Olive cake	From extraction of pomace oil (olive)
Recovered FFA	Vegetable oil refining
Toasted meal	Oilseed processing
Crude cake and spent meal/cake	Oilseed processing
Phospholipids	Vegetable oil refining
Spent bleaching earth (in the absence of a nickel catalyst) in integrated crushing/refining	Oilseed processing
Product retrieved from wrongly filled containers, e.g. by maceration of packaging	Dairies, but applicable to all FDM industries producing foods suitable for use in animal feed
Leaked and spilt ingredients and partly and fully processed materials	Dairies, but applicable to all FDM industries producing foods suitable for use in animal feed
Rinsings from yoghurt vats	Dairies
Whey which is not intended for making mitzithra cheese, baby food or other products	Dairies
Milky waste water generated at the start-up of pasteurisers	Dairies
Cereals, fibre, gluten, vegetable protein and de-fatted meal	Cereals processing
Wet pulp, pressed or dried pulp from the pressing of cossettes	Extraction of sugar from sugar beet
Beet tops and tails separated from sugar beet reception fluming and washing	Extraction of sugar from sugar beet
Molasses	Sugar extraction
Vinasse produced during the processing of alcohol from sugar juices, syrups and molasses	Ethanol production
Distiller's dried grains with solubles (DDGS)	Ethanol production
Condensed stillage (CDS)	Ethanol production
Gluten, bran	Ethanol and starch production
Malt	Beer, lager and whisky production (from germinated kiln-dried grain)
Husk and malt grits, which may be mixed into brewers' grains and trub	Breweries
Concentrated or dried stillage, pot ale, spent lees and spent wash	Whisky stills
Fermentation vessel cooling water containing raw materials and fermented produce residues	Whisky distilleries
Fermentation yeast	Breweries, ethanol production
Solid organics such as raw material and product residues and dust	Dehydration
Solids and oils removed from segregated waste water streams	Snack foods manufacturing
<i>Source: [192, COM 2006], [193, TWG 2015]</i>	

Alternatively, residues can be used for by-products to implement the circular economy principles. By-products are defined in the Waste Directive [59, WFD 98/EC 2008].

Achieved environmental benefits

Increased use of materials and reduced waste generation. Consequently there is an associated reduced consumption of, for example, energy for waste treatment and disposal, e.g. in WWTPs, and reduced landfilling of FDM waste.

Environmental performance and operational data

No information provided.

Cross-media effects

Some materials may need to be stored under controlled temperature conditions, before their use as animal feed.

Technical considerations relevant to applicability

The technique may not be applicable due to legal requirements. It is applicable in FDM installations using raw materials and partially processed ingredients and producing products which are suitable for consumption by animals, either directly or after further processing, and which comply with relevant legislation governing animal feed.

Economics

Reduced purchase of materials and reduced waste treatment and disposal costs.

Driving force for implementation

Economic use of by-products, off-specification products and excess materials, which would otherwise be sent for disposal as waste.

Example plants

This technique is widely applied in FDM installations [193, TWG 2015].

Reference literature

[1, CIAA 2002], [6, Environment Agency of England and Wales 2000], [8, Environment Agency of England and Wales 2000], [14, VITO et al. 2001], [35, Germany 2002], [48, European Starch Association 2001], [59, WFD 98/EC 2008], [71, AWARENET 2002], [75, FEDIOL 2002], [90, Verband Deutscher Oelmuehlen 2003], [175, ePURE 2015], [192, COM 2006], [193, TWG 2015]

2.3.5.3 Separation of residues

Description

Separation of residues, e.g. using positioned splash protectors, screens, flaps, catchpots, drip trays and troughs.

Technical description

Outputs, whether or not they are intended for use in the product, can be separated for optimised and easier use, reuse, recovery, recycling and disposal. This also reduces both the consumption and the contamination of water. It can be done either manually or mechanically. These outputs may include rejected raw materials, trimmings and off-specification product.

Accurately positioned splash protectors, screens, flaps, drip trays and troughs can be used to contain individual materials separately. They can be fitted at processing, filling/packing and transfer lines and next to workstations, such as peeling, cutting and trimming benches. The position and design of a tray or trough for example, the means of preventing mixing with water and the transportation of the liquids or solids depend on the unit operation, the degree of segregation of different materials desired or required and their ultimate intended use, or disposal route.

A catchpot is a fine mesh basket placed over floor drains, to prevent solids from entering the drainage system and the WWTP. Catchpots can be locked in place to ensure that solids are not able to enter the WWTP during cleaning. If they are emptied after dry cleaning and locked in place again before wet cleaning, then entrainment of soluble materials and of particles can be avoided.

Examples of materials which can be collected and transported dry include bones and fat from deboning and trimming meat. These may or may not be intended for human consumption. For materials destined for human consumption, temperature control is particularly important and deterioration can be avoided by quickly transferring the materials to chills.

Other examples include removal of sorted, untreated or partly treated fruit and vegetable residues, peel and cutting residues and collecting spent earth in sedimentation and filtration steps instead of washing it into the WWTP.

Where the amount of potential waste is high, manual or automated collection systems such as drains, pumps or suction devices can be installed, to minimise deterioration and maximise potential use, e.g. in animal feed. This also mitigates against the possibility of materials being washed into the WWTP during interval cleaning.

In the dairy industry, examples of materials which can be collected separately for optimal use or disposal include the drainings of yoghurt and fruit throughout the dairy; first rinses of buttermilk and residual fat in butter churning operations, for use in other processes, for example for low-fat spreads and whey, e.g. for making mizithra cheese (see Section 5.4.4.1). In vegetable oil refining, dust produced during drying of desolventised meal can be added to the meal again (see Section 11.4.2.2.1).

Some water-diluted materials can be recovered, if the water is collected, e.g. potato starch can be recovered from starch water, as described under Environmental performance and operational data, and whey can be extracted from whey/water mixtures. This can be optimised by using turbidity meters. Additionally, materials can be recovered for use or disposal by using dry cleaning methods.

Achieved environmental benefits

Benefits include reduced water consumption and less entrainment of materials in water, so generation of less waste water. If materials are collected efficiently, the volume of water required for cleaning is reduced and consequently less energy is used to heat the cleaning water. Less detergent is also required. The waste water load of, for example, BOD, COD, nutrient and detergent emission levels are all reduced, per unit of production.

The segregation of liquids and solids destined for use or destruction has several advantages. If sufficient separate collection systems are provided, it reduces cross-contamination between different by-products. Segregation of by-products reduces potential odour problems from materials which, even when fresh, emit the most offensive odours, i.e. by storing/removing them separately under controlled conditions, instead of having to control a greater volume of mixed by-products.

Also, by minimising cross-contamination, segregation enables individual by-products which can be used to be used, instead of being disposed of because they are mixed with materials which cannot be used. All materials can, therefore, be used or disposed of in the most appropriate way for them.

Environmental performance and operational data

The following examples show how segregation can result in cleaner waste water, reduced water consumption and reduced waste.

In fish processing, using baskets or trays at cutting, eviscerating, skinning, and filleting can avoid the solid wastes reaching the floor and then the waste water. Fine mesh conveyor belts can be used to separate waste and water at cutting and evisceration stations and can reportedly decrease COD emission levels by about 40 %. The collected solid materials can be used to make fishmeal.

Dry systems have been developed for collecting solid waste from crustaceans and molluscs. Screens and efficient systems for the recovery of solids prevents them from entering the WWTP and can reportedly lead to BOD₅ reduction of up to 35 %.

In an example installation producing snack foods, waste water streams were segregated prior to on-site treatment and then treated to remove solids and oils, which were then processed into animal feed cake. This was as a result of a water action group consisting of managers, shift operators and the site adviser using a bucket-and-stopwatch approach to study the ideal flow rates for each piece of equipment. The results of this water audit showed that substantial savings could be made. Three main waste streams were identified, i.e. potato wash water, cold starch water and hot starch water containing oils.

In fruit and vegetable processing, solid organic material from the peeling process and from blanching can be separated using, for example, sieves, filters or centrifuges, to prevent them from entering the WWTP. Normally these solids, except after caustic peeling, can be used as animal feed.

Cross-media effects

Potential generation of odour if separated solids are not periodically collected and sent to their subsequent destination.

Technical considerations relevant to applicability

Applicable to all FDM installations.

Economics

The 165 000 m³/year reduction in water consumption at the example snack food installation saved a reported EUR 145 000 in water supply costs.

Driving force for implementation

- Reduced waste because recovered materials can be used.
- Reduced waste water treatment and waste disposal and the associated reduced costs.

Example plants

At least one snack food installation in the UK. Dairies in the UK and fruit and vegetable processing installations in Belgium. Widely applied in drinks manufacturing, e.g. in winemaking.

Reference literature

[1, CIAA 2002], [9, Envirowise (UK) 1998], [14, VITO et al. 2001], [23, Envirowise (UK) and Ashact 2001], [43, Italian contribution 2002], [71, AWARENET 2002]

2.3.5.4 Recovery and reuse of residues from the pasteuriser

Description

Residues from the pasteuriser are fed back to the blending unit and are thereby reused as raw materials.

Technical description

Combining in-line blending and pasteurisation makes it possible to recover mixed phases containing water from the pasteuriser. The diluted product is reused in the production line. Figure 2.14 shows the possibilities of recovery.

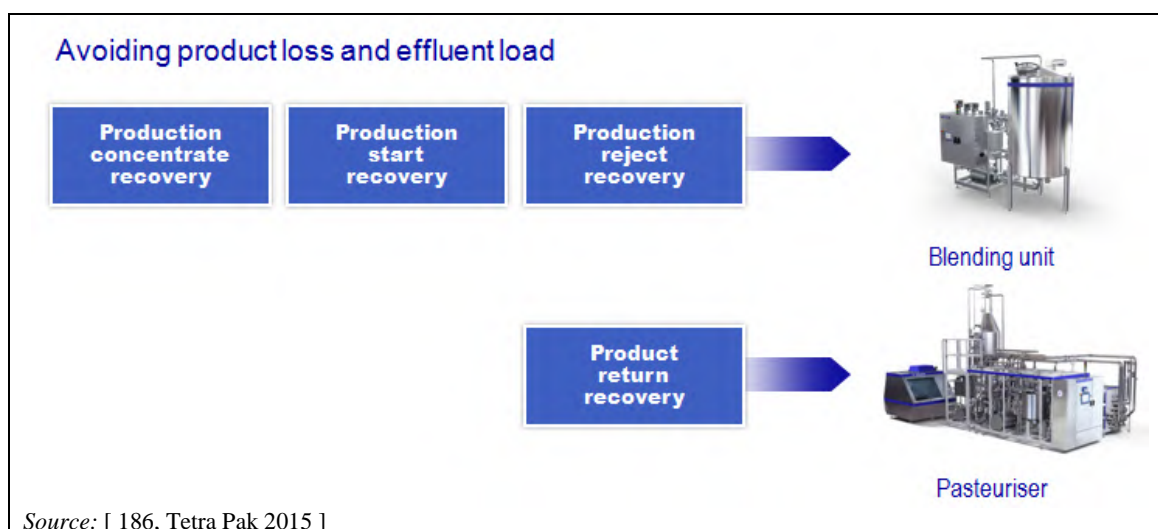

Figure 2.14: Scheme for beverage processing with in-line blending and recovery functions

The terms used in Figure 2.14 are defined as follows:

- **Production concentrate recovery:** the premix tanks before the blending unit are emptied in order to concentrate the recovered phases and to achieve zero product losses in the blending unit.
- **Production start recovery:** the mixed phase in the pasteuriser is returned to the blending unit, which concentrates it up to real product levels. A recovery rate of 100 % can be achieved. A densimeter on this stream is used to identify which part of the phase is product and which is water. The blending unit and the pasteuriser communicate with each other to know where the product and water phases are.
- **Production reject recovery:** if for some reason the production line stops and the pasteuriser needs to be emptied and go into hibernation mode, all the product in the pasteuriser is recovered and routed into the buffer tank of the blending unit. This option does not generate losses and does not require an extra reject tank.
- **Product return recovery:** a product recovery function between the pasteuriser and the packaging machine minimises the losses.

Achieved environmental benefits

In-line production reduces the need to invest in batch tanks. Running production with fewer tanks will:

- save water and CIP solution due to the lower number of tanks to clean;
- save power due to the reduced amount of electrical equipment;
- give a better yield due to the recovery functions and accuracy of the machine;
- reduce the effluent volume and COD load due to the recovery functions.

Environmental performance and operational data

No information provided.

Cross-media effects

No information provided.

Technical considerations relevant to applicability

The technique is applicable in new and existing liquid food processing installations.

Economics

No information provided.

Driving force for implementation

- Increased yield.
- Improved product quality.
- Saved time in the blending area since operators prepare less tanks.
- Increased capacity.

Example plants

This technique has been implemented worldwide.

References

[186, Tetra Pak 2015]

2.3.5.5 Phosphorus recovery as struvite

Information on this technique is available in Section 2.3.6.4.1.

2.3.5.6 Use of waste water for landspreading**Description**

After appropriate treatment, waste water is used for landspreading in order to take advantage of the nutrient content and/or to use the water.

Technical description

Effluents of FDM industries contain water and fertilising nutrients coming mainly from the raw materials. Their return to agriculture is an option, considering the large amounts of fertilisers replaced when landspreading is done according to the crops' needs. Waste water landspreading allows the recycling of organic matter and fertilising elements to agricultural soil. It has benefits in terms of:

- substitution of chemical fertilisers (N, P, K) which sometimes represent very significant amounts, with a subsequent positive economic impact;
- improvement of soil conditions as a consequence of the addition of organic matter;
- contribution to crop management and to productivity of farming activities (that can rely on reliable continuity of water supply);
- reduction of water use and soil erosion.

Waste water treatment prior to landspreading may be performed for different reasons, e.g.:

- to recover the residual energy (biogas) in the waste water;
- to reduce odour emissions during storage (aerated tanks or lagoons, reduced storage time, etc.);
- to separate the solid phase to be exploited separately, for example for material landspreading.

Achieved environmental benefits

Prevention or reduction of waste water entering the WWTP.

Environmental performance and operational data

In a French potato starch installation, the effluent is spread on fields by means of a network of hundreds of kilometres of underground pipes. Fertilising elements (including N, CaO, P and K₂O) and micropollutants are monitored. Controls on underground water are performed through piezometers or analysis of drinking water boreholes. Analysis is also carried out on soil, with an agronomic analysis coupled with a residual nitrogen test, and followed by fertilisation advice. Every parcel is monitored all along its life cycle. Rotations avoid any over-fertilisation, thus the authorised surface is five times larger than the yearly surface actually spread. The landspreading is also controlled by the competent authorities.

Cross-media effects

Energy is required to operate the system. Sufficient land must be available for spreading. Odour can arise during spreading, and weather and soil conditions must be taken into account.

Technical considerations relevant to applicability

This technique is only applicable in the case of a proven agronomic benefit, a proven low level of contamination and no negative impact on the environment (e.g. on the soil, the groundwater and surface water). The applicability may be restricted due to the limited availability of suitable land adjacent to the installation. The applicability may be restricted by the soil and local climatic conditions (e.g. in the case of wet or frozen fields) or by legislation.

Economics

No information provided.

Driving force for implementation

Reduction of costs for waste water treatment.

Example plants

Effluent landspreading is a practice applied in some MS (e.g. DE, DK, ES, FR). It is estimated that around 10 % of the French IED FDM installations apply landspreading of waste water. Waste water for landspreading can be generated from different FDM installations, e.g.:

- starch sector: potato food juice, starch purification;
- fruit and vegetable sector: washing water (washing of vegetables) and blanching water;
- sugar sector: earthy water (washing of beetroots) and decanted water.

References

[222, France 2015]

2.3.6 Waste water treatment techniques

2.3.6.1 Preliminary, primary and general treatment

In this document, the term primary treatment is used to describe what is sometimes described as primary treatment, preliminary treatment or pretreatment.

2.3.6.1.1 Equalisation

Description

Balancing of flows and pollutant loads by using tanks or other management techniques.

Technical description

Equalisation tanks or buffer storage are normally provided to cope with the general variability in flow and composition of waste water, or to provide corrective treatment, e.g. pH control or chemical conditioning. The need to equalise waste water discharges may need to be considered to ensure that the flow and composition of the waste water are within the design parameters of the WWTP.

Achieved environmental benefits

Enables downstream treatment techniques to operate at the optimum efficiency. Makes use of mixing effects to offset extremes of temperature or pH.

Environmental performance and operational data

Adequate mixing and aeration is needed to minimise the formation of scum on the surface of the equalisation tank and to maintain a sufficient dissolved oxygen level to ensure the contents do not become anaerobic, leading to acidity and odour. Nevertheless, where necessary, scum removal equipment is installed.

Equalisation tanks typically have a retention time of 6–12 hours. However, in Scandinavian countries the retention time may be up to several months. For example, many FDM installations in Finland store the waste water generated during autumn and winter in big pools, due to the difficulties to operate the biological waste water treatment during these periods [166, COM 2015].

Cross-media effects

Excessive retention of waste water in the equalisation tank may lead to acidity and odour.

Technical considerations relevant to applicability

Widely applicable in the FDM sector.

Economics

The cost of constructing and operating an equalisation tank needs to be compared with the cost savings associated with the smooth running of the downstream treatment techniques.

Driving force for implementation

To present a virtually homogeneous feed to downstream WWTP processes.

Example plants

Equalisation tanks are widely used in the FDM sector [193, TWG 2015].

Reference literature

[1, CIAA 2002], [8, Environment Agency of England and Wales 2000], [166, COM 2015], [193, TWG 2015]

2.3.6.1.2 Neutralisation

Description

The adjustment of the pH of waste water to a neutral level (approximately 7) by the addition of chemicals. Sodium hydroxide (NaOH) or calcium hydroxide (Ca(OH)₂) is generally used to increase the pH, whereas sulphuric acid (H₂SO₄), hydrochloric acid (HCl) or carbon dioxide (CO₂) is generally used to decrease the pH. The precipitation of some substances may occur during neutralisation.

Technical description

The objective of neutralisation is to avoid the discharge of strongly acidic or alkaline waste water. It can also protect downstream waste water treatment processes. The following substances are normally used to neutralise waste water which has a low pH:

- limestone, limestone slurry or milk of lime (hydrated lime Ca(OH)₂);
- caustic soda (NaOH) or sodium carbonate (Na₂CO₃);
- ion exchangers (cationic).

The following substances are normally used to neutralise waste water which has a high pH:

- CO₂, e.g. hot gas and gas from fermentation processes;
- sulphuric acid (H₂SO₄), nitric acid (HNO₃) or hydrochloric acid (HCl);
- ion exchangers (anionic).

The term self-neutralisation is used when, in some cases, the size of the equalising tank, in combination with suitable variations in the pHs of the waste water streams, means that no addition of chemicals is required. This can occur for example in some dairies where both acidic and alkaline cleaning solutions are used and are both sent to the neutralisation tank.

Achieved environmental benefits

Avoids the effects of strongly acidic or strongly alkaline waste water, i.e. corrosion, reduction of the efficiency of biological treatments and/or a reduction in the self-purifying properties of lakes and rivers, and possibly operating problems for other water users.

Environmental performance and operational data

In the brewery sector, the neutralisation can take place in production areas or in central neutralisation tanks with acid or caustic. The neutralisation of process waste water requires a tank with a hydraulic retention time of approximately 20 minutes. The mixing capacity should be sufficient to keep the tank completely mixed. Since both caustic and acidic cleaning agents are used at the breweries, a reduction in chemical usage for neutralisation can be obtained by increasing the hydraulic retention time in the neutralisation tank. Neutralisation tanks are often also used as equalisation tanks (see Section 2.3.6.1.1) with a hydraulic retention time of 3–6 hours [72, Brewers Europe 2002].

Furthermore, partial neutralisation through biological conversion will normally take place in process waste water from the brewery sector. It has been observed that the pH in equalisation tanks can drop without the addition of acids due to the hydrolysis of organic material. The effect is difficult to control but it reduces the dosing requirements of acid to caustic process waste water. To achieve biological acidification, a hydraulic retention time of 3–4 hours is required.

Cross-media effects

Due to the addition of chemicals to the waste water, the dissolved solids/salt content may increase significantly in the treated water and the solid waste produced might be difficult to dispose of.

Technical considerations relevant to applicability

Generally, there are no technical restrictions to the applicability of this technique.

Economics

No information provided.

Driving force for implementation

Legal requirements. To improve the biological treatability of the waste water in the WWTP.

Example plants

Neutralisation is widely used in FDM installations [193, TWG 2015].

Reference literature

[5, German Dairy Association 1999], [35, Germany 2002], [72, Brewers Europe 2002], [193, TWG 2015]

2.3.6.1.3 Screening

Description

The use of a device with openings, generally of uniform size, to retain the coarse solids found in waste water.

Technical description

After solids are removed with process-integrated techniques and prevented from entering the waste water, e.g. using catchpots located at drainage points inside the installation, further solids can be removed from the waste water using screening. Large quantities of non-emulsified FOG can be removed if screening is carried out together with technical and operational measures to avoid clogging.

A screen is a device with openings, generally of uniform size, that is used to retain the coarse solids found in waste water. The screening element consists of parallel bars, rods or wires, grating or a wire mesh or perforated plate. The openings may be of any shape but are generally circular or rectangular slots. The spacing between bars for removing very coarse materials prior to finer screening may be of 20–60 mm. To remove smaller particles, such as vegetable pieces, e.g. peas and beans in a canned food factory, the spacing between bars generally does not exceed 5 mm. The openings in automatic screens range from 0.5 mm to 5 mm, with openings of 1–3 mm in widespread use. Smaller openings (1–1.5 mm) are reported to be less susceptible to blockage than larger ones (2–3 mm).

The main types of screens used are static (coarse or fine), vibrating and rotary screens.

Static screens, brushed or run-down, can comprise vertical bars or a perforated plate. This type of screen requires manual or automatic cleaning.

Vibrating screens require rapid motion to be effective. They are normally used for primary treatments associated with by-product recovery, particularly of solids with a low moisture content and preferably where the waste water does not contain grease. Vibrating screens operate between 900 rpm and 1 800 rpm; the motion can either be circular, rectangular or square, varying from 0.8 mm to 12.8 mm. The speed and motion can be selected according to the particular application. Of prime importance in the selection of a proper fine vibrating screen is the application of the correct combination of wire strength and percentage of open area. The capacities of vibrating screens are based on the percentage of open area of the screen media.

Rotary or drum screens receive the waste water at one end and discharge the solids at the other. The liquid is passed outward through the screen to a receiving box for forward transfer. The screen is usually cleaned by a continuous spray via external spray nozzles, which are inclined towards the solids discharge end. This type of screen is effective for streams containing a relatively high solids content. Microscreens mechanically separate solid particles from the waste water by means of microscopically fine fabrics. The most important operating parameter is the headloss, i.e. the loss of operating pressure, with the best separation results reported to be between 5 mbar and 10 mbar.

Achieved environmental benefits

Reduced SS, FOG and BOD/COD emission levels. Recovery of products, e.g. pulp in the fruit and vegetable sector. Reduced risk of odour emissions further downstream in the WWTP.

Environmental performance and operational data

The estimated pollution load reduction in the fish sector, when using rotary wedge wire screens, is around 10–20 % from white fish effluents and about 30–40 % from fatty fish effluents [71, AWARENET 2002].

In the fish sector, it has been reported that the removal of small solids is carried out using a filtration belt and vibrating screen with a filter mesh of 0.1 mm or less.

The blockage of screens is a common problem, leading to the need for frequent cleaning. A curved sieve can be used to overcome blockages. This consists of a feeding device and a concave surface; and it is self-cleaning in operation. Wedge-shaped profiled rods are arranged perpendicularly to the flow direction of the water. A relatively steady overflow ensures that the screen cleans itself. The various screen segments are all interchangeable. Typical gap widths are 0.02–2 mm for sieve areas of 0.1–3.0 m² (maximum throughput 300 m³/m²/h). Curved screens are frequently used in fruit and vegetable factories. Alternatively, rotary screens equipped with self-cleaning may be used. When the blockage is due to fatty deposits, e.g. in the meat, dairy and fish sectors, regular chemical cleaning and/or hot water cleaning can be applied.

Cross-media effects

There may be odour emissions, depending, for example, on the type and size of the solids screened.

Technical considerations relevant to applicability

Applicable in all FDM installations.

Economics

No information provided.

Driving force for implementation

Reduced waste water treatment requirements. Screening removes the need for, and therefore the cost of, additional waste water treatment. It reduces the amount of sludge produced, which would otherwise require additional expenditure for its disposal.

Example plants

Used in most of the FDM sectors, as shown in Table 2.4 [193, TWG 2015].

Reference literature

[13, Nordic Council of Ministers 1997], [35, Germany 2002], [71, AWARENET 2002], [193, TWG 2015]

2.3.6.1.4 Fat trap or oil separator for the removal of FOG and light hydrocarbons

Description

A fat trap (or oil separator) is a plumbing device designed to intercept most greases before they enter the biological waste water treatment.

Technical description

FOG in waste water has a negative impact on the performance of the waste water treatment. It is therefore important to remove FOG in a pretreatment. If FOG is not removed prior to aerobic biological treatment, it may hinder the operation of the WWTP as it is not easily degraded by bacteria. Free FOG may be separated from water using a fat trap (grease interceptor). Similar equipment is used to separate light hydrocarbons.

A further development of the fat trap is the parallel-plate separator. Here, the separator chamber contains plates inclined at an angle of 45 °. Furthermore, combinations of augers and flotation tanks have been used for FOG removal.

Achieved environmental benefits

Removal of free FOG from the waste water. The system does not usually require any chemical additions so the recovered fats may be reused.

Environmental performance and operational data

The efficiency of separation is increased if the water temperature is low. The presence of emulsifiers can also reduce the separation efficiency. It has been reported that an efficiency of 95 %, related to the free oil/fat content, can be achieved [35, Germany 2002]. Parallel-plate separators are very sensitive to clogging in the processing of vegetable oils.

In a primary stage of a dairy installation (#405), solids are removed using twin compacting augers. This reduces the solids volume by approximately 90 %. The augers will squeeze congealed FOG through the filter mesh for recovery. The primary tank is heated to enable the liquefaction of all FOG content. The hydraulic separator then removes the FOG from the waste effluent by means of flotation. This process will typically remove FOG to below 100 ppm and often less than 30 ppm. Fat should not solidify, so the pipework and tank must be kept warm.

The correct sizing of chambers is critical to ensure proper separation and to avoid the danger of washout during high or abnormal flows. Flow diversion may be needed if inflows suffer large fluctuations. Ease of emptying and regular maintenance are essential to prevent odour problems.

Cross-media effects

The equipment requires energy consumption. Depending on the type of fat trap, e.g. without continuous fat removal, there may be odour emissions, particularly during emptying.

Installing fat traps within processing areas can cause food safety problems. Excessively hot water can cause fats to carry through and may melt pre-collected fat, so it should be avoided. The baffle material and ease of cleaning need to be considered.

Technical considerations relevant to applicability

Applicable in FDM installations with waste water containing animal and vegetable FOG.

Economics

An investment cost of EUR 500 000 and annual operating cost of EUR 8 000 have been reported for the installation of an integrated oil separator in a dairy (treating around 480 000 m³/year). Around 70 % of operating costs is electricity for heating, and 30 % for the maintenance contract. The investment required is outweighed by the EUR 400 000 of annual savings in waste water treatment, EUR 5 000/year savings in sludge treatment and EUR 3 000/year transport cost savings [193, TWG 2015].

Driving force for implementation

Reduction in problems caused by fat in waste water pipelines and the WWTP.

Example plants

Used in most of the FDM sectors [193, TWG 2015].

Reference literature

[35, Germany 2002], [94, Germany 2003], [97, CIAA-FEDIOL 2004], [193, TWG 2015]

2.3.6.1.5 Buffer storage for waste water**Description**

A buffer tank capable of receiving typically 2–3 hours of peak waste water flow.

Technical description

Contingency measures can be provided to prevent accidental discharges from processes damaging the WWTP and/or the operation of the MWWTP, by them receiving a sudden high load. A buffer (or diversion) tank capable of receiving typically 2–3 hours of peak flow can be established. The waste water streams are monitored upstream of the WWTP so that they can be automatically sidetracked to the buffer system if necessary. The buffer tank is linked back to the equalisation tank (see Section 2.3.6.1.1) or primary treatment stage so that out-of-specification liquors can be gradually introduced back into the waste water stream. Alternatively, provision can be made to allow the disposal of the diversion tank contents off site. Buffer tanks are also applied where there is no separate drainage system for surface water and it could enter the on-site WWTP. More detailed information on buffer storage is available in the CWW BREF [168, COM 2016].

Achieved environmental benefits

Avoids uncontrolled and untreated discharges of waste water.

Environmental performance and operational data

This technique is successfully used in wine production, where the pH of waste water is normally higher than 5. Fractions of high loaded waste water can be detected with pH peaks. A lower pH is a strong indicator of product loss of undiluted wine or juice. The undiluted wine or juice is sidetracked to a buffer tank and is gradually introduced into the equalisation tank.

Cross-media effects

There are no cross-media effects associated with this technique.

Economics

Investment costs of EUR 150 000 have been reported for the installation of two buffer tanks (2 x 90 m³) including the measurement and control system.

Driving force for implementation

Compliance with legal requirements to limit pollution to a receiving water body.

Technical considerations relevant to applicability

Lack of space and/or the layout of the waste water collection system in existing plants can limit the applicability.

Example plants

This technique is widely used in FDM installations [193, TWG 2015].

Reference literature

[168, COM 2016], [193, TWG 2015]

2.3.6.2 Secondary treatment

2.3.6.2.1 Aerobic treatment

2.3.6.2.1.1 Activated sludge process

Description

A biological process where the microorganisms are maintained in suspension in the waste water and the whole mixture is mechanically aerated. The activated sludge mixture is sent to a separation facility from where the sludge is recycled to the aeration tank..

Technical description

The activated sludge technique produces an activated mass of microorganisms capable of stabilising a waste aerobically. The general arrangement of an activated sludge process for removing carbonaceous matter includes the following items:

- aeration tank where air (or oxygen or a combination of the two) is injected into the mixed liquor;
- settling tank (usually referred to as the final clarifier or secondary settling tank) to allow the biological flocs to settle, thus separating the biological sludge from the clear treated water.

Treatment of nitrogenous matter involves additional steps where the mixed liquor is left in an anoxic condition (see Section 2.3.6.3.1).

Achieved environmental benefits

Reduced BOD, TOC or COD, phosphorus and nitrogen emission levels.

Environmental performance and operational data

After a given residence time, which can vary from several hours to an excess of 10 days, based on an organic loading rate or F/M ratio of about 0.1–0.15 kg BOD/kg of MLSS per day, the mixed suspension of microorganisms is passed to a sedimentation facility (see Section 2.3.6.5.2) The hydraulic retention time or sludge age and F/M ratio can all vary as a function of the raw waste water characteristics, e.g. composition, availability and degradability of organic substances, and the required final waste water quality. For example, nitrification occurs with lower (< 0.1 kg BOD/kg of MLSS per day) F/M ratios. In the sedimentation facility, the settlement of microbial flocs occurs and clear waste water is passed over a weir to a watercourse. Settled sludge is produced and mostly returned to the aeration tank. However, a proportion, i.e. the excess sludge, is wasted to maintain MLSS at a reasonable level, e.g. 3 000 mg/l [78, Metcalf & Eddy 1991].

The performance data of an activated sludge WWTP in the brewery sector is shown in Table 2.49.

Table 2.49: Performance data of an activated sludge WWTP reported for the brewing sector

Initial load (kg COD/m³ per day)	1.2–1.8
Final BOD level (mg/l)	15–25
Sludge generated per kg of BOD removed (TSS/kg)	0.45–0.55
NB: These performance figures are valid at a temperature range of 25–35 °C and thus not applicable during winter. <i>Source:</i> [72, Brewers Europe 2002]	

Phosphorus removal efficiencies of 20–30 % have been reported using activated sludge [146, Desmidt et al. 2015].

In the sugar sector, it has been reported that low winter air and water temperatures depress the treatment capacity as bacterial activity is reduced. However, low-grade waste heat from the sugar process can usually be used to increase temperatures in the system and enhance bacterial activity.

The most common problem associated with activated sludge is that of bulking. This term is used to describe biological sludge of poor settling characteristics. It is generally due to the presence of filamentous bacteria and/or excessive water bound within biological flocs. Bulking can be prevented by, for example, ensuring that the optimum balance of added nutrients is maintained, minimising both the release of nutrients and the overproduction of filamentous bacteria. In addition, the use of a separate compartment or selector has been recognised as a good tool to prevent and control filamentous growth. This is an initial contact zone where the primary waste water and the returned sludge are combined.

In the dairy sector, sludge bulking has been reported in activated sludge systems with fluctuating loads and low F/M ratios, e.g. insufficient BOD. If a selector is not used, the final sedimentation needs to be designed according to the inferior sludge settling characteristics.

To ensure that the activated sludge has enough nutrients, phosphoric acid and/or urea may be added to the influent in the event that the concentration of TP and/or TN is too low.

Cross-media effects

These include high energy consumption for aeration combined with mixing in the aeration tank. Installation #466 reported an energy use of approximately 2.2 kWh/kg of COD [193, TWG 2015]. Volatile waste water content can be released into the atmosphere, giving rise to odour. Aerobic biological treatment produces a relatively large amount of excess activated sludge that needs to be disposed of.

Technical considerations relevant to applicability

Widely used in the FDM sector. The technique can be used to treat high- or low-BOD waste water, but will treat low-BOD water highly efficiently and cost-effectively.

Economics

The activated sludge technique provides a cost-effective treatment of soluble organic matter.

Driving force for implementation

Compliance with legal requirements to limit pollution to a receiving water body.

Example plants

This technique is widely used in FDM installations [193, TWG 2015].

Reference literature

[35, Germany 2002], [72, Brewers Europe 2002], [78, Metcalf & Eddy 1991], [109, Finland 2003], [146, Desmidt et al. 2015], [193, TWG 2015]

2.3.6.2.1.2 Aerobic lagoon

Description

Shallow earthen basins for the biological treatment of waste water, the contents of which are periodically mixed to allow oxygen to enter the liquid through atmospheric diffusion.

Technical description

Aerobic lagoons are large shallow earthen basins that are used for the treatment of waste water by natural processes. They involve the use of algae, bacteria, sun and wind. Oxygen, in addition to that produced by algae, enters the liquid through atmospheric diffusion. The contents of the lagoons are normally mixed periodically using pumps or surface aerators.

A variation on the aerobic lagoon is the facultative lagoon, where stabilisation is brought about by a combination of aerobic, anaerobic and facultative bacteria. Oxygen can be maintained in the upper layer of a facultative lagoon by surface re-aeration.

Achieved environmental benefits

Reduced BOD, TOC or COD, phosphorus and nitrogen emission levels.

Cross-media effects

Potential odour nuisance, soil deterioration and groundwater contamination. Energy consumption for aeration combined with mixing in the lagoon.

Environmental performance and operational data

It has been reported that lagoons provide buffer capacity due to large areas and volumes, volume and concentration equalisation in seasonal operations, and that they establish adapted biocoenoses given very long residence times. Depending on the soil characteristics, lagoons may need to be sealed, to avoid groundwater contamination.

In the sugar sector, it has been reported that surface area and depth are key elements in the rate of degradation of BOD. Degradation of BOD relies on natural processes such as the carbon, nitrogen and sulphur cycles, and the action of the bacteria. Furthermore, surface aeration is used in this sector to increase the rate of aerobic bacterial activity when needed, e.g. at low temperatures. Additional oxygen is diffused into the water by electrically driven free or fixed floating aerators. Occasionally, wind-powered aerators are used where weather conditions are favourable. Mixed wind and electrical systems are available.

The use of evaporation lagoons has been reported in wineries and olive oil mills. The waste water is left to evaporate in open basins for months.

Technical considerations relevant to applicability

The application of this technique may be restricted due to space requirements. This technique can be used to treat high- or low-BOD waste water, but will treat low-BOD water highly efficiently and cost-effectively.

Economics

No information provided.

Driving force for implementation

The technique is used to comply with waste water legislation and to reduce waste water charges/fees.

Example plants

Lagoons are widely used in most of the FDM sectors [193, TWG 2015].

Reference literature

[35, Germany 2002], [88, CIAA-CEFS 2003], [109, Finland 2003], [193, TWG 2015]

2.3.6.2.1.3 Pure oxygen systems

Description

The injection of pure oxygen into an existing conventional aeration plant.

Technical description

Pure oxygen systems are essentially an intensification of the activated sludge process, i.e. the injection of pure oxygen into an existing conventional aeration plant. This is often undertaken after increased or variable plant production which has rendered the aeration plant ineffective, for at least some part of its operational cycle.

Achieved environmental benefits

Reduction of BOD, TOC or COD, phosphorus and nitrogen emission levels. In comparison with activated sludge systems, odour, noise and TVOC emissions are reduced as the surface of the aeration tank is essentially unbroken; and energy use is reduced.

Environmental performance and operational data

Compared to the conventional activated sludge process, pure oxygen systems have the ability to intensify the process by operating at a higher MLSS level. Furthermore, this technique uses less energy since 70 % of the energy in conventional activated sludge is wasted due to the nitrogen occupying 70 % of the air by volume [78, Metcalf & Eddy 1991].

Cross-media effects

These include energy consumption for aeration combined with mixing in the aeration tank. Aerobic biological treatment produces a relatively large amount of excess activated sludge that needs to be disposed of.

Technical considerations relevant to applicability

Generally, there are no technical restrictions to the applicability of this technique. As well as in new installations, a number of pure oxygen systems have been retrofitted in the FDM sector.

Economics

Since the system is operating with extremely long sludge ages and encouraging endogenous respiration, whereby the biomass ingests itself, there is a significant reduction of sludge disposal costs. Nevertheless, plants that use oxygen instead of air have higher operational costs.

Driving force for implementation

The use of pure oxygen improves control and performance and can be retrofitted to existing plants.

Example plants

This technique has been reported in several installations of the brewing, starch, dairy, meat and fruit and vegetable sectors [193, TWG 2015].

Reference literature

[8, Environment Agency of England and Wales 2000], [78, Metcalf & Eddy 1991], [193, TWG 2015]

2.3.6.2.1.4 Sequencing batch reactors (SBR)

Description

The various stages of the activated sludge processes are all carried out within the same reactor.

Technical description

The SBR is a variant of the activated sludge process. It is operated on the fill and draw principle and normally consists of two identical reaction tanks. The various stages of the activated sludge processes are all carried out within the same reactor.

Achieved environmental benefits

Reduction in BOD, TOC or COD, phosphorus and nitrogen emission levels.

Environmental performance and operational data

The process is very flexible as a number of process changes are possible within the operating cycles, e.g. enhanced denitrification during the idle phase. A typical total cycle period is about 6 hours. The time taken for each stage of the process can be adjusted to suit local circumstances. Finally, the process sequence is independent of any influences caused by hydraulic input fluctuations. In this sense, SBR has a simpler and more robust operation if sufficient capacity is installed, i.e. fill and draw system rather than conventional activated sludge process.

Since batch-wise filling leads to the formation of a readily settling activated sludge, this process is suitable for industrial waste water that has a tendency towards bulking sludge. The normal operation of a typical SBR is shown in Table 2.50.

Table 2.50: Characterisation of a typical SBR

Step	Purpose	Operation (aeration)	Maximum volume (%)	Cycle time (%)
Fill	Add substrate	Air on/off	25–100	25
React	Biological degradation	Air on/cycle	100	35
Settle	Clarify	Air off	100	20
Draw	Remove waste water	Air off	35–100	15
Idle*	Waste sludge	Air on/off	25–35	5

NB:* Waste sludge may occur in other steps as well. In multi-tank systems, the idle phase is used to provide time for the second tank to be filled. This step may be omitted.
Source: [192, COM 2006]

Cross-media effects

These include energy consumption for aeration combined with mixing in the aeration tank. Aerobic biological treatment produces a relatively large amount of excess activated sludge that needs to be disposed of.

Technical considerations relevant to applicability

Generally, there are no technical restrictions to the applicability of this technique. This technique can be used to treat high- or low-BOD waste water, but will treat low-BOD waste water very efficiently and cost-effectively.

Economics

Lower capital and higher operational costs than the conventional activated sludge process.

Driving force for implementation

The technique is used to comply with waste water legislation and to reduce waste water charges/fees.

Example plants

This technique has been reported in several installations of the dairy, brewing, meat, oilseed and fruit and vegetable sectors [193, TWG 2015].

Reference literature

[1, CIAA 2002], [35, Germany 2002], [78, Metcalf & Eddy 1991], [192, COM 2006], [193, TWG 2015], [226, EDA 2016]

2.3.6.2.1.5 Trickling filters

Description

Waste water is distributed over a filter medium where biomass grows as a film.

Technical description

In fixed-film aerobic systems such as trickling filters, the biomass grows as a film on the surface of packaging media and the waste water is distributed so as to flow evenly across it. The trickling filter medium normally consists of rocks or various types of plastic. The treated liquid is collected under the media and passed to a settling tank from where part of the liquid can be recycled to dilute the pollutant load of the incoming waste water. Variations include alternating double filtration or permanent double filtration.

Achieved environmental benefits

Reduction in BOD, TOC or COD, phosphorus and nitrogen emission levels.

Environmental performance and operational data

It has been reported that in the dairy sector high-rate trickling filters are typically designed to remove 50–60 % BOD. For an efficient operation, it is essential that FOG emission levels are minimised prior to being fed into the high-rate filter. Following high-rate filtration, secondary sedimentation may be required, depending upon the consent to discharge conditions. In the soft and alcoholic drinks sector, this technique is reported to be 70 % effective, so a further polishing step is normally needed. Phosphorus removal efficiencies of 8–12 % have been reported using trickling filters [192, COM 2006].

Cross-media effects

Potential odour nuisance. Energy consumption for waste water distribution.

Technical considerations relevant to applicability

This technique is applicable for waste water with a relatively low BOD, or as a polishing stage after an activated sludge process or high-rate filtration. Its use within the FDM sector has decreased because of the relatively large land area it requires and because of operational problems due to blockage.

Economics

No information provided.

Driving force for implementation

The technique is used to comply with waste water legislation and to reduce waste water charges/fees.

Example plants

Used in the fish, dairy, soft and alcoholic drinks and vegetable oils and fats sectors. High-rate trickling filters have been used at some dairies in the UK. The FDM data collection showed that this technique is in use in one installation (#471) from the oilseed processing and refining sector [193, TWG 2015].

Reference literature

[192, COM 2006], [193, TWG 2015]

2.3.6.2.1.6 Bio-towers

Description

Tanks where microbial film adheres to the plastic media contained and consumes the organic material. The waste water is often recycled through the bio-tower.

Technical description

Waste water from the processing of FDM often has an organic load too high for conventional aerobic treatment. Consequently, treatment is necessary to reduce the BOD to an acceptable level prior to further treatment, e.g. at a MWWTP. Bio-towers or roughing filters are specially designed trickling filters (see Section 2.3.6.2.1.5) operated at high organic loading rates that can achieve high levels of BOD removal.

The technique uses above-ground tanks containing plastic media with a high surface area. Microbial film adheres to the media and consumes the organic material. The waste water is often recycled over the bio-tower to achieve a further treatment. The waste water from these units is then discharged to a conventional biological process.

Achieved environmental benefits

Reduced BOD, TOC or COD, phosphorus and nitrogen emission levels.

Environmental performance and operational data

Plastic media of the type used in bio-towers has a surface area ratio of 100–240 m²/m³. Loading rates of 0.5 kg BOD/m³/day have been reported to achieve over 90 % removal; up to 60 % removal is possible with loadings of 2.5 kg BOD/m³/day. Blockage and unstable sludge might occur.

Cross-media effects

Potential odour nuisance. Noise emissions may arise from blowing air into the bio-tower.

Technical considerations relevant to applicability

Applicable in all FDM installations with a high organic load in the waste water.

Economics

No information provided.

Driving force for implementation

Bio-towers are an effective method for reducing BOD to something closer to that of domestic sewage.

Example plants

This technique has been reported in several installations of the dairy, brewing and starch sectors [193, TWG 2015].

Reference literature

[1, CIAA 2002], [8, Environment Agency of England and Wales 2000], [78, Metcalf & Eddy 1991], [193, TWG 2015]

2.3.6.2.1.7 Rotating biological contactors (RBC)

Description

An RBC consists of a series of closely spaced circular discs of polystyrene or polyvinyl chloride. The discs are submerged in waste water and rotated slowly through it.

Technical description

In operation, biological growths become attached to the surface discs and eventually form a slime layer over the entire wetted surface area of the discs. The rotation of the discs alternately puts the biomass into contact with the organic material in the waste water and then with the atmosphere for the adsorption of oxygen. The rotation is also the mechanism for removing excess solids from the discs so they can be carried from the unit to a sedimentation tank.

Achieved environmental benefits

Reduced BOD, TOC or COD, phosphorus and nitrogen emission levels.

Environmental performance and operational data

Properly designed RBCs are reliable because of the large amount of biological mass present (low operating F/M ratio). This large quantity of biomass also permits them to withstand hydraulic and organic surges more effectively. Staging in this plug-flow system eliminates short-circuiting and dampens shock loadings. It is reported that blockage of the discs may occur. Phosphorus removal efficiencies of 8–12 % have been reported using RBCs.

Cross-media effects

Potential odour nuisance.

Technical considerations relevant to applicability

Generally, there are no technical restrictions to the applicability of this technique.

Economics

No information provided.

Driving force for implementation

The technique is used to comply with waste water legislation and to reduce waste water charges/fees.

Example plants

Used in the fish and vegetable oils and fats sectors. The FDM data collection showed that this technique is in use in one installation (#406) from the dairy sector [193, TWG 2015].

Reference literature

[78, Metcalf & Eddy 1991], [193, TWG 2015]

2.3.6.2.1.8 High- and ultra-high-rate aerobic filters

Description

Biological treatment of waste water where air is introduced through the nozzle, providing a high shear force on the bacteria and an intense degree of turbulence/oxygenation.

Technical description

High- and ultra-high-rate aerobic filters give the potential for higher than usual loading rates to aerobic systems. The process employs a high waste water recycling rate, directed through an integral nozzle assembly. Air is introduced through the nozzle, providing a high shear force on the bacteria and an intense degree of turbulence/oxygenation. It is this high shear force undergone by the bacteria which makes this process so different from other aerobic techniques, i.e. microorganisms are passed through the nozzle resulting in the existence of only very small bacteria in the system, which differs from other systems where bacteria are not subjected to such shear and where higher life forms also exist.

Achieved environmental benefits

Reduced BOD, TOC or COD, phosphorus and nitrogen emission levels.

Cross-media effects

High energy consumption.

Environmental performance and operational data

Ultra-high-rate aerobic systems offer the potential for loading aerobic systems up to 50–100 times more than conventional aerobic treatment. Nevertheless, since they do not give a quality of waste water suitable for river discharge, a second aerobic stage, which is more conservatively loaded, is required.

Technical considerations relevant to applicability

Generally, there are no technical restrictions to the applicability of this technique.

Economics

Reduced capital investment.

Driving force for implementation

Reduced plant size and capital investment.

Example plants

This technique has been reported in two FDM installations belonging to the starch production sector [193, TWG 2015].

Reference literature

[193, TWG 2015]

2.3.6.2.2 Anaerobic treatment

High loaded waste water streams (high COD) are normally treated in an anaerobic waste water treatment plant. Organic solids are usually treated in a digester. Companies that do not have enough organic solid waste in general cannot install a digester. Some of them feed this solid waste to their anaerobic waste water treatment unit. This results in a higher amount of biogas, but can also result in a higher concentration of recalcitrant COD. Therefore the load of solid materials sent to the anaerobic waste water treatment plant should generally be reduced. This can be done by, for example, installing a suitable sieve at the entrance of the anaerobic treatment plant or installing a sedimentation unit at the entrance of the anaerobic treatment plant. All solids collected could be sent to a digester.

2.3.6.2.2.1 Upflow anaerobic sludge blanket (UASB) process

Description

An anaerobic process where waste water is introduced at the bottom of the reactor from where it flows upward through a sludge blanket composed of biologically formed granules or particles. The waste water phase passes into a settling chamber where the solid content is separated; the gases are collected in domes at the top of the reactor.

Technical description

In the UASB system, the waste water is directed to the bottom of the reactor for uniform distribution. The waste water passes through a blanket of naturally formed bacterial granules with good settling characteristics so that they are not easily washed out of the system. The bacteria carry out the reactions and then natural convection raises a mixture of gas, treated waste water and sludge granules to the top of the reactor. Patented three-phase separator arrangements are used to separate the final waste water from the solids (biomass) and the biogas.

Achieved environmental benefits

Reduced BOD and TOC or COD emission levels and sludge stabilisation.

Environmental performance and operational data

Loadings of up to 60 kg COD/m³ per day have been reported, but a more typical loading rate is 10 kg COD/m³ per day with a hydraulic retention time of 4 hours [8, Environment Agency of England and Wales 2000]. Table 2.51 shows the reported performance of a UASB reactor in the brewing sector.

Table 2.51: Reported performance of a UASB reactor in the brewing sector

Initial load (kg COD/m³ per day)	5–10
Final COD level (mg/l)	100–500
Sludge generated per kg of COD removed (TSS/kg)	0.04–0.08
NB: Further treatment is necessary to discharge waste water with these concentrations to a receiving water body. <i>Source: [72, Brewers Europe 2002]</i>	

One disadvantage of the UASB reactor is the technique's sensitivity to FOG. Fat emission levels have to be below 50 mg/l in the waste water; otherwise they have a detrimental effect on the process. On the other hand, a particular advantage of the process is the formation of pellets. This allows not only rapid reactivation after months-long breaks in operation, but also the sale of surplus sludge pellets, e.g. for the inoculation of new systems. This process is particularly suitable for waste water with a low solid content and with relatively low influent COD levels (< 2 000 mg/l) and when a small surface area is available.

Cross-media effects

There is a need for an additional downstream biological (aerobic) treatment. Odour abatement might be necessary.

Technical considerations relevant to applicability

Applicable in FDM installations with waste water containing a high load of soluble wastes.

Economics

Investment costs of EUR 850 000 have been reported, including an equalisation tank, UASB reactor, equipment for biogas utilisation for hot water production (treating around 200 m³/day of waste water and a COD load around 2.5 t COD/day).

Investment costs of EUR 2 million have been reported including pretreatment (equalisation tank, dissolved air flotation (DAF)), UASB reactor, optimisation of existing aerobic biological treatment, biogas conditioning (drying, compression) for treatment of around 1 000 m³/day of waste water and a COD load of around 4.5 t COD/day.

Driving force for implementation

- Pretreatment of waste water with high TOC or COD and BOD loads before aerobic treatment.
- Energy recovery from methanisation.

Example plants

This technique has been reported in several FDM installations belonging to the dairy, fruit and vegetable, brewing, starch and sugar sectors [193, TWG 2015]. Sludge bed reactors are the most widespread used reactors in the FDM sector.

Reference literature

[8, Environment Agency of England and Wales 2000], [72, Brewers Europe 2002], [116, CIAA-AAC-UFE 2003], [168, COM 2016], [193, TWG 2015]

2.3.6.2.2.2 Anaerobic contact process

Description

An anaerobic process where waste water is mixed with recycled sludge solids and then digested in a sealed reactor. The water/sludge mixture is separated externally.

Technical description

Untreated waste water is mixed with recycled sludge and then digested in a reactor sealed off from the entry of air. The waste water/sludge mixture is externally separated (e.g. by sedimentation or by DAF). The anaerobic contact process can be linked to the aerobic activated sludge process, as separation and recirculation of the biomass is incorporated into the design. The anaerobic degradation process results in a mixture of methane and carbon dioxide in a ratio of 1/1 to 3/1, thus producing a combustible gas with a high energy content which is normally used for fuel replacement or other energy supply facilities.

Achieved environmental benefits

Reduced BOD and TOC or COD emission levels and sludge stabilisation. Reduced generation of sludge compared to aerobic processes.

Environmental performance and operational data

Compared with the high-performance processes of UASB (see Section 2.3.6.2.2.1) and expanded and fluidised bed reactors (see Section 2.3.6.2.2.6), contact stabilisation processes do not produce such high biomass concentrations in the reactor and are, therefore, run at comparatively lower space loadings (usually up to 5 kg COD/m³ per day). Their main advantage, however, lies in their relatively trouble-free operation and, in particular, their lack of clogging problems.

Since the anaerobic sludge produces gas outside the reactor and the gas volume continues to rise, there is frequently a need for a degasification unit between the methane reactor and the separator unit. The degasification may be achieved by means of vacuum degassing, stripping, cooling or slowly rotating agitators. This feature allows the process to be operated at 6–14 h retention times.

In a fruit and vegetable installation (#030), the addition of an anaerobic stage as a first step in an existing waste water treatment plant led to an organic load reduction of more than 60 %. In a brewery installation (#360), waste water was treated in an anaerobic reactor with a capacity of 8 000 m³/d and 40 000 kg COD/day, achieving an 80 % reduction in COD emission levels [193, TWG 2015].

Cross-media effects

Normally, anaerobic processes are run as biological high-load stages that need an additional downstream biological (aerobic) treatment. Compared with aerobic processes, the energy consumption is considerably less, because energy is not needed for air or oxygen supply to the reactor, only for efficient stirring.

The arising of combustible gases and the formation of metabolites such as short-chain carboxylic acids make the use of closed equipment necessary to prevent the efflux of odour. Odour abatement might be necessary.

Technical considerations relevant to applicability

Applicable in FDM installations with waste water containing a high load of soluble wastes.

Economics

An investment cost of EUR 1 600 000 and annual operating cost of EUR 50 000 have been reported for the anaerobic treatment stage, associated with a WWTP capacity of 2 500 m³/day [193, TWG 2015].

Driving force for implementation

- Pretreatment of waste water with high TOC or COD and BOD loads before aerobic treatment.
- Energy recovery from methanisation.

Example plants

This technique is reported in various FDM sectors [193, TWG 2015].

Reference literature

[8, Environment Agency of England and Wales 2000], [78, Metcalf & Eddy 1991], [193, TWG 2015]

2.3.6.2.2.3 Anaerobic lagoons

Description

Shallow earthen basins for the anaerobic treatment of waste water, the contents of which are not mixed.

Technical description

Anaerobic lagoons are similar to aerobic lagoons (see Section 2.3.6.2.1.2), with the difference that the contents of anaerobic lagoons are not mixed [78, Metcalf & Eddy 1991]. They may give rise to odour problems, due to H₂S emissions [116, CIAA-AAC-UFE 2003]. In the soft and alcoholic drinks sector, it has been reported that anaerobic lagoons are more than 2 m deep.

Achieved environmental benefits

Reduced BOD and TOC or COD emission levels and sludge stabilisation.

Environmental performance and operational data

No information provided.

Cross-media effects

Potential odour nuisance, soil deterioration and groundwater contamination.

Technical considerations relevant to applicability

Applicable in FDM installations with waste water containing a high load of soluble wastes.

Economics

No information provided.

Driving force for implementation

To pretreat waste water with high TOC or COD and BOD loads before aerobic treatment.

Example plants

This technique has been reported in several FDM installations belonging to the sugar manufacturing sector [193, TWG 2015].

Reference literature

[78, Metcalf & Eddy 1991], [116, CIAA-AAC-UFE 2003], [193, TWG 2015]

2.3.6.2.2.4 Anaerobic filters

Description

The growth of anaerobic bacteria is established on a packaging material.

Technical description

In the anaerobic filter, the growth of anaerobic bacteria is established on a packaging material. The packaging retains the biomass within the reactor and it also assists in the separation of the gas from the liquid phase. The system can be operated in the upflow or downflow mode.

Achieved environmental benefits

Reduced BOD and TOC or COD emission levels and sludge stabilisation.

Environmental performance and operational data

Because the bacteria are retained on the media and do not wash off in the waste water, mean cell residence times in the order of 100 days can be obtained. The technique is suitable for treating heavily polluted waste water with a COD concentration of 10 000–70 000 mg/l.

In a dairy (#296), an anaerobic filter is installed and designed to treat 4 500 m³ of effluent and to achieve a COD reduction of between 80 % and 90 %. The system achieves a COD reduction of 80 % on a consistent basis. The filter vessel is randomly packed with plastic rings which provide a host for the growth of fixed biofilms. The system is designed as a downflow system whereby the effluent is pumped to the top of the vessel from where it is directed to a series of sprinkler heads which disperse the water over the bed. The effluent falls through the bed via gravity and is collected at the base. It is noted that a recirculation loop is incorporated within the anaerobic system to recirculate approximately 50 % of the flow to the top of the bed. Biogas generated from the system is collected from the top of the tank and is directed to a CHP plant for electricity generation. The anaerobic plant uses approximately 680 kWh of electricity per day. Overall, the system is a net producer of electricity with 350 litres of methane produced per kg of COD [193, TWG 2015].

Cross-media effects

There is a need for an additional downstream biological (aerobic) treatment. Odour abatement might be necessary.

Technical considerations relevant to applicability

Applicable in FDM installations with waste water containing a high load of soluble wastes.

Economics

No information provided.

Driving force for implementation

- Pretreatment of waste water with high TOC or COD and BOD loads before aerobic treatment.
- Energy recovery from methanisation.

Example plants

This technique has been reported in two FDM installations (#296, #378) belonging to the dairy sector [193, TWG 2015].

Reference literature

[1, CIAA 2002], [8, Environment Agency of England and Wales 2000], [35, Germany 2002], [78, Metcalf & Eddy 1991], [193, TWG 2015]

2.3.6.2.2.5 Internal circulation (IC) reactors

Description

Two UASB reactor compartments can be put on top of each other, one high-loaded and one low-loaded.

Technical description

There is a special configuration of the UASB process (see Section 2.3.6.2.2.1), i.e. the IC reactor, in which two UASB reactor compartments can be put on top of each other, one high-loaded and one low-loaded. The biogas collected in the first stage drives a gas-lift, resulting in an internal recirculation of the waste water and sludge, hence the process name.

Achieved environmental benefits

Reduced BOD and TOC or COD emission levels and sludge stabilisation.

Environmental performance and operational data

One of the main advantages of the IC reactor is that it can undergo a certain amount of self-regulation, irrespective of the variations in incoming flows and loads. As the load increases, the quantity of methane generated also increases, and further increases the degree of recirculation and hence dilution of the incoming load. Typical loading rates for this process are in the range of 15–35 kg COD/m³ per day [8, Environment Agency of England and Wales 2000].

Cross-media effects

No information provided.

Technical considerations relevant to applicability

Applicable in FDM installations with waste water containing a high load of soluble wastes.

Economics

No information provided.

Driving force for implementation

- Pretreatment of waste water with high TOC or COD and BOD loads before aerobic treatment.
- Energy recovery from methanisation.

Example plants

This technique has been reported in several FDM installations belonging to the brewing, oilseed processing and refining, starch and dairy sectors [193, TWG 2015].

Reference literature

[8, Environment Agency of England and Wales 2000], [193, TWG 2015]

2.3.6.2.2.6 Fluidised and expanded bed reactors

Description

Anaerobic filter where the particles and the biomass are completely mixed.

Technical description

These reactors are similar to the anaerobic filters (see Section 2.3.6.2.2.4). If the particles and biomass are completely mixed, the process is known as a fluidised bed, whereas a partially mixed system is known as an expanded bed.

Achieved environmental benefits

Reduced BOD and TOC or COD emission levels and sludge stabilisation.

Environmental performance and operational data

To achieve high volume-time yields of 15–35 kg COD/m³ per day, it is absolutely essential to fill the methane reactors with as constant a volume of adequately acidified solids-free waste water as possible. For this reason, all large-scale systems have been built as two-stage systems, i.e. with a separate acidification stage. In large-scale systems, the influent waste water for treatment has relatively low pollution loads with an average COD level of between 1 500 mg/l and 3 600 mg/l [35, Germany 2002].

In the fluidised bed reactor the carrier material is constantly in motion, with a bed expansion of 50 % or more. The carrier material (usually sand but sometimes pumice or plastic pellets) is kept in suspension by means of high recirculation rates. The recirculation is strong enough to keep the carrier material in suspension, but care should be taken to ensure that excessive circulation does not cause the biomass to become detached from the carrier material.

The expanded bed reactor also incorporates support media, often sand or synthetic plastic materials. Light materials are often used to minimise the upflow velocities required to fluidise the beds and particle sizes are typically in the range of 0.3–1.0 mm [8, Environment Agency of England and Wales 2000].

Cross-media effects

There is a need for an additional downstream biological (aerobic) treatment. Odour abatement might be necessary.

Technical considerations relevant to applicability

Applicable in FDM installations with waste water containing a high load of soluble wastes.

Economics

No information provided.

Driving force for implementation

- Pretreatment of waste water with high TOC or COD and BOD loads before aerobic treatment.
- Energy recovery from methanisation.

Example plants

Used in the sugar sector. This technique has also been reported in one FDM installation (#096) belonging to the oilseed sector [193, TWG 2015].

Reference literature

[8, Environment Agency of England and Wales 2000], [35, Germany 2002], [193, TWG 2015]

2.3.6.2.2.7 Expanded granular sludge bed reactors (EGSB)

Description

A UASB reactor operated with a greater depth of granular sludge and a higher water rise rate.

Technical description

EGSB reactors use granular sludge of the type found in UASB reactors (see Section 2.3.6.2.2.1) but they operate with a greater depth of granular sludge and a higher water rise rate. The digester uses recirculated treated water and is fitted with a three-phase (solid, liquid, gas) separator.

Achieved environmental benefits

Reduced BOD and TOC or COD emission levels and sludge stabilisation.

Environmental performance and operational data

Loading rates up to 35 kg COD/m³ per day have been reported [8, Environment Agency of England and Wales 2000]. The water rise rate is typically 3 m³/h, compared to 1 m³/h for a UASB. The initial commissioning/acclimatisation phase is not long for EGSB reactors. Table 2.52 shows the reported performance of an EGSB reactor in the brewing sector.

Table 2.52: Reported performance of an EGSB reactor in the brewing sector

Initial load (kg COD/m³ per day)	15–25
Final COD level (mg/l)	100–500
Sludge generated per kg of COD removed (SS/kg)	0.04–0.08
NB: Further treatment is necessary to discharge waste water with these concentrations to a receiving water body <i>Source:</i> [72, Brewers Europe 2002]	

In an example molasses distillery, an EGSB reactor treats the condensed vapours from the condensation unit and the singlings from distillation/rectification. The reactor reduces the COD load in the downstream activated sludge unit. The methane gas produced is burned in a CHP plant, to generate electricity and heat. The high efficiency of the reactor results in the production of only small quantities of surplus aerobic sludge. In this example, it is concentrated in a decanter and used for agricultural purposes or disposed of to a MWWTP.

Cross-media effects

There is a need for an additional downstream biological (aerobic) treatment. Odour abatement might be necessary.

Technical considerations relevant to applicability

Applicable in FDM installations with waste water containing a high load of soluble wastes.

Economics

Investment costs of EUR 3 900 000 have been reported including pretreatment (sieve, equalisation tank, dissolved air flotation (DAF)), EGSB reactor, aerobic treatment step (nitrification, denitrification), filter, biogas conditioning and utilisation for hot water production (treating around 1 500 m³/day of waste water and a COD load of around 3.5 t COD/day).

Driving force for implementation

- Pretreatment of waste water with high TOC or COD and BOD loads before aerobic treatment.
- Energy recovery from methanisation.

Example plants

This technique has been reported in several FDM installations belonging to the sugar, ethanol brewing, oilseed processing and refining, starch and dairy sectors [193, TWG 2015].

Reference literature

[8, Environment Agency of England and Wales 2000], [35, Germany 2002], [72, Brewers Europe 2002], [193, TWG 2015]

2.3.6.2.3 Aerobic/anaerobic treatment

2.3.6.2.3.1 Membrane bioreactor (MBR)

Description

A combination of activated sludge treatment and membrane filtration. Two variants are used: a) an external recirculation loop between the activated sludge tank and the membrane module; and b) immersion of the membrane module in the aerated activated sludge tank, where the effluent is filtered through a hollow fibre membrane, with the biomass remaining in the tank.

Technical description

A MBR is a variation on a conventional activated sludge treatment whereby a number of membrane modules, or cartridges, replace the secondary clarifier and the tertiary filtration step (see Figure 2.15). Following biological treatment, the mixed liquor is pumped under static head pressure to the membrane unit where the solids and liquids are separated, the clean waste water is discharged, and the concentrated mixed liquor is pumped back to the bioreactor.

The MBR can be operated in either aerobic or anaerobic mode, thereby increasing the range of suitable chemicals, e.g. used for membrane cleaning in biological treatment. Typical arrangements consist of vacuum-driven membrane units submerged in the aerated part of the bioreactor or pressure-driven membrane systems located outside the bioreactor. Membranes are typically configured hollow tube fibres or flat panels and have pore sizes ranging from 0.1 microns to 0.4 microns.

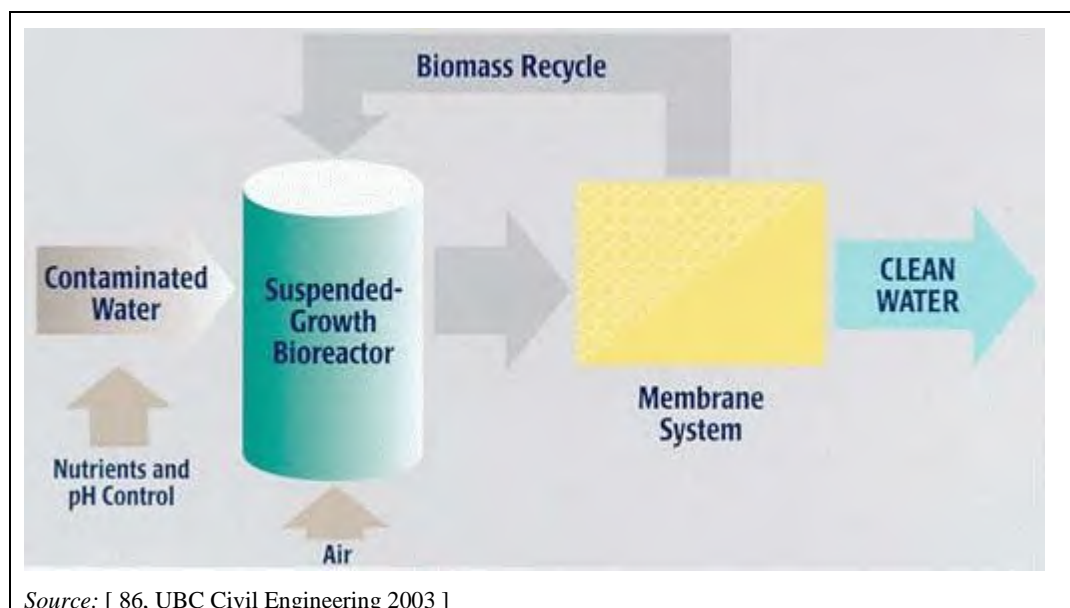

Source: [86, UBC Civil Engineering 2003]

Figure 2.15: Simplified process flow diagram of the MBR system

Achieved environmental benefits

The achieved environmental benefits of the use of a membrane bioreactor include [168, COM 2016]:

- reduction of the load of suspended solids, COD or TOC, BOD, and TP by 95–99 %;
- reduction of the microbiological health risk to levels that comply with Directive 2006/7/EC concerning the management of bathing water quality;
- reduction of the volume of sludge compared to conventional aerated sludge treatment;
- reduction of the plant footprint compared to conventional aerated sludge treatment, especially if tertiary filtration and a UV disinfection unit are necessary to achieve comparable output quality.

Environmental performance and operational data

A MBR operates across a range of loading rates, but can achieve a higher treatment rate in a number of ways, i.e. increased static pressure increases the amount of dissolved oxygen thereby aiding mass transfer; using oxygen instead of air; and using a multistage system to optimise the process. For oil and grease applications, concentrations of BOD in the waste water may be reduced to less than 15 mg/l.

A MBR provides highly efficient biomass separation, allowing the biomass concentration within the upstream reactor to be up to 10 times greater than the concentration normally attainable in a conventional suspended growth system. When using a MBR, no secondary sedimentation is required and:

- very broad MLSS levels can be achieved in the bioreactor, i.e. 12–17 000 mg/l;
- very low COD and TSS emission levels can be achieved after treatment; the dairy installation #409 reported emission levels in the range of 2–4 mg COD/l and 4.6–11 mg TSS/l as yearly averages [193, TWG 2015].

The energy consumption, for pumping, might be significantly higher than in conventional activated sludge processes but it can be minimised by applying gravity feed to the waste water. An example dairy in Ireland treats 9 000 m³ of waste water per day to high standards for discharge to a local watercourse, applying gravity feed to make the process low-energy-intensive. The dairy installation #409 reported an energy consumption of 2.6–3.2 kWh/m³ of waste water treated when applying ultrafiltration almost continuously, and reverse osmosis to reuse waste water in the CIP process when needed.

Fouling of the membranes may be a major problem. Aeration and backwashing are used to control this problem, which may result in additional waste water being produced. DAF (see Section 2.3.6.5.4) is used to scour and clean the membrane surfaces to prevent biofouling.

Cross-media effects

Cross-media effects include energy consumption (mainly for pumping and aeration) and chemical consumption (for membrane cleaning), as well as membrane replacement.

Technical considerations relevant to applicability

A MBR is applicable in all FDM installations. This technique has the advantage of having low space requirements. This system is ideal for higher-pollutant-load, lower-volume waste water. It is especially attractive in situations where a long solids retention time is required to achieve the necessary biological degradation of the pollutants. Furthermore, waste water containing not readily degradable compounds, e.g. phenols, pesticides, herbicides and chlorinated solvents, and high organic pollution can be treated with a MBR. Advantages and disadvantages compared to the conventional activated sludge process are given in Table 2.53.

Table 2.53: Advantages and disadvantages associated with membrane bioreactors

Advantages	Disadvantages
<ul style="list-style-type: none"> • Smaller space requirements • Reduced amount of sludge (compared to conventional activated sludge system) • For medium to highly loaded influents (3–30 g/l of COD), a major benefit of MBR treatment plants is the ability to keep a good efficiency with inlet COD variations, whereas keeping the same performance with a conventional activated sludge plant requires larger equalisation tanks than with MBRs • Contrary to a conventional clarifier, the MBR system may act as a physical barrier in upset conditions • Can operate at much higher solids concentrations (typically 8 000–12 000 mg/l) compared to the conventional activated sludge system (typically 3 000–6 000 mg/l) • Once abrasion and pressure variations are under control, ceramic membranes have constant performance without aging loss 	<ul style="list-style-type: none"> • High energy costs because of the high pressure drop and high air flushing rate required for its operation • Membranes are sensitive to abrasion so, when retrofitting an existing WWTP with a MBR unit, it should be verified that abrasion will not occur (e.g. the quality of the concrete of the tanks should be checked) • Silicones in the influent must be prohibited as they rapidly plug the membranes • Pressure variations must be controlled as membranes are sensitive and can break
<p><i>Source:</i> [168, COM 2016]</p>	

Economics

High energy costs, although the operating costs are comparable to or lower than an alternative aerobic waste water treatment with similar emission levels to those obtained by a MBR.

Driving force for implementation

Possibility to reuse the water and therefore reduced costs.

Example plants

This technique has been reported in several FDM installations belonging to the dairy, fruit and vegetable, and oilseed processing and refining sectors [193, TWG 2015]. Example installations include #401, #406 and #409.

Reference literature

[8, Environment Agency of England and Wales 2000], [86, UBC Civil Engineering 2003], [153, UK TWG 2004], [168, COM 2016], [193, TWG 2015]

2.3.6.2.3.2 Multistage systems

Description

Combination of various aerobic and anaerobic techniques for waste water treatment.

Technical description

The various aerobic and anaerobic waste water treatment processes can be applied alone or in combination. When they are applied in combination arranged in series, the technique is called multistage systems. Waste water treatment takes place successively in individual stages, which are kept separate from each other by means of separate sludge circuits.

The following process combinations are generally used:

- activated sludge/activated sludge;
- trickling filter/trickling filter;
- trickling filter/activated sludge;
- activated sludge/trickling filter;
- lagoons/activated sludge;
- lagoons/trickling filter;
- activated sludge/UASB reactor.

Achieved environmental benefits

Reduced BOD and TOC or COD emission levels.

Environmental performance and operational data

In various FDM sectors, a two-stage biological system, anaerobic followed by aerobic, can be used to achieve a quality of waste water suitable for reuse or direct discharge to a watercourse.

The waste water from the oilseed installation (#086) for the processing of rape and soybeans, and the refining of rape, soya and palm oil, is generated from several unitary operations such as vacuum systems (by the use of vacuum ejectors), water and acid degumming, hexane recovery techniques, and wet scrubbers for air cleaning purposes, among others. The COD concentration of the waste water lies between 1 000 mg/l and 5 000 mg/l, which is mainly comprised of a mixture of long-chain fatty acids and volatile fatty acids. The waste water is treated in two consecutive stages: anaerobic treatment, by the use of a high-rate UASB reactor, and an activated sludge process divided into a high-load and a low-load phase. Phosphoric acid is used (0.5 m³/month) as a source of phosphorus in the anaerobic reactor. Each stage includes aeration basins and DAF units for sludge separation. The electricity consumption of the waste water treatment plant is 187 000–212 000 kWh per month. The global removal efficiency is 96–98 % for total COD (49 mg/l as a yearly average). The removal of total nitrogen is normally in the range of 65–85 %. The removal of phosphorus lies between 15 % and 40 %. Biogas is produced at a rate of 0.27–0.7 Nm³ per kg of COD removed in the anaerobic reactor. The biogas is used in the cogeneration plant to reduce natural gas consumption [193, TWG 2015].

In a sugar manufacturing installation (#412), the water used to convey sugar beet into the factory is separated from the beet using vibrating screens. The water, containing soil washed from the beet (during the fluming of the beet), is passed to a clarifier where the soil concentration is increased. The overflow from the clarifier is returned to the fluming system while the underflow is passed to settlement lagoons. Some natural treatment of the BOD in the water occurs in these lagoons while the soil settles. The water from these lagoons is then passed to anaerobic/aerobic treatment; where there is an excess of water for treatment, a certain quantity will be stored for water treatment. The effluent from the anaerobic treatment stage is split. Part is recycled to the fluming system to control pH and odour, while the rest is passed to anoxic and aerobic treatment, where it is co-processed with condensate that contains ammonia. The aerobic treatment has a removal capacity of approximately 7 tonnes of COD per day with an influent COD concentration of 1 000 mg/l and effluent COD concentration of 150 mg/l at 300 m³/d [193, TWG 2015].

Cross-media effects and Driving force for implementation

Those indicated for the corresponding techniques combined.

Technical considerations relevant to applicability

Applicable in FDM installations with highly polluted waste water.

Economics

An operating cost of EUR 2–3 per m³ of treated waste water was reported for an activated sludge/UASB reactor system.

An annual operating cost of around EUR 650 000 (costs of fuel, electricity, consumables, labour and maintenance) was reported for a combined aerobic and anaerobic waste water treatment system with a capacity of around 1 300 000 m³/year [193, TWG 2015].

Example plants

This technique has been reported in several FDM installations belonging to the sugar, dairy, soft drinks and juice and starch sectors [193, TWG 2015].

Reference literature

[193, TWG 2015]

2.3.6.3 Nitrogen removal

2.3.6.3.1 Nitrification and denitrification

Description

A two-step process that is typically incorporated into biological waste water treatment plants. The first step is the aerobic nitrification where microorganisms oxidise ammonium (NH₄⁺) to the intermediate nitrite (NO₂⁻), which is then further oxidised to nitrate (NO₃⁻). In the subsequent anoxic denitrification step, microorganisms chemically reduce nitrate to nitrogen gas.

Technical description

A more detailed technical description of biological nitrification and denitrification can be found in the CWW BREF [168, COM 2016].

Achieved environmental benefits

Nitrogen emission levels are reduced and energy is saved.

Environmental performance and operational data

This technique has a potential to achieve a high removal efficiency, a high process stability and reliability, relatively easy process control and space requirements.

In the starch sector, it is reported that nitrification and denitrification reactions occur in an anoxic medium which can be obtained either by a sequenced aeration of the activated sludge tank or in a separate anoxic zone. The removal of nitrogen is carried out using preceding denitrification.

Cross-media effects

Biological nitrification and denitrification imply the consumption of energy. In some cases, an external carbon source needs to be added.

Technical considerations relevant to applicability

Nitrification may not be applicable in the case of high chloride concentrations (e.g. above 10 g/l) and if the reduction of the chloride concentration prior to nitrification would not be justified by the environmental benefits. Moreover, the nitrification process may not be applicable when the temperature of waste water is low (e.g. below 12 °C). This technique is not applicable when the final treatment does not include a biological treatment.

Economics

Investment costs of EUR 1 300 000 are reported for an aerobic treatment step for nitrification and denitrification (treating around 1 500 m³/day of waste water, a COD load of around 1.0 t COD/day and a total nitrogen load of 150 t TN/day).

Driving force for implementation

Member States' legislation to reduce eutrophication of fresh water.

Example plants

This technique is widely used in FDM installations [193, TWG 2015].

Reference literature

[35, Germany 2002], [14, VITO et al. 2001], [78, Metcalf & Eddy 1991], [168, COM 2016], [193, TWG 2015]

2.3.6.3.2 Partial nitritation-anaerobic ammonium oxidation**Description**

A biological process that converts ammonium and nitrite into nitrogen gas under anaerobic conditions. In waste water treatment, anaerobic ammonium oxidation is preceded by a partial nitrification (i.e. nitritation) that converts about half of the ammonium (NH_4^+) into nitrite (NO_2^-).

Technical description

The anaerobic ammonium oxidation process is used for nitrogen removal instead of the classic nitrification-denitrification process. This conversion is a shortcut in the natural nitrogen cycle where ammonium and nitrite are converted to nitrogen gas. In a first aerated step (preventing conditions for nitrate formation), ammonium is oxidised to nitrite; then the conversion of nitrite to nitrogen gas takes place in an anaerobic second step where the relevant bacteria are present.

Achieved environmental benefits

Nitrogen emission levels are reduced and energy is saved.

Environmental performance and operational data

The conventional activated sludge treatment of waste water in a Dutch potato processing installation (#453) was retrofitted with a partial nitritation-anaerobic ammonium oxidation process in 2011. An additional tank was built for the implementation of the process. The applied process has a total nitrogen (TN) removal efficiency of around 90 %. As one oxidation step (nitrite→nitrate) is avoided by applying the partial nitritation-anaerobic ammonium oxidation process, less oxygen/air is used. Also, lower amounts of sludge are generated, in relation to the classic nitrification-denitrification process. Ammonium and nitrate are monitored in the aerated tank to optimise the oxygen supply. The organic load is also monitored and adjusted through recirculation of waste water.

Cross-media effects

Ammonium oxidation implies the consumption of energy.

Technical considerations relevant to applicability

This technique is not applicable when the final treatment does not include a biological treatment. The technique may not be applicable when the temperature of waste water is low.

Economics

The operational costs of the WWTP can be reduced to around 60 % compared to a conventional nitrification/denitrification step.

Driving force for implementation

Member States' legislation to reduce eutrophication of fresh water.

Example plants

The technique is applied to various FDM installations.

Reference literature

[55, COM 2017]

2.3.6.3.3 Ammonia stripping

Description

Waste water is brought into contact with a high flow of an airstream in order to transfer ammonia from the water phase to the gas phase.

Technical description

In the FDM sector, condensate, which contains high concentrations of ammonium, can be stripped of ammonia in a two-step system. The system consists of a desorption and an adsorption column, which are both filled with packaging material to increase the water-air interface.

The desorption column is charged with an alkalisated condensate from the top, to shift the $\text{NH}_4^+ - \text{NH}_3$ equilibrium in the direction of NH_3 , which subsequently drops downwards in the column. At the same time, air is injected at the base of the column. In the countercurrent process, a transfer of ammonia, therefore, takes place from the aqueous phase into the gaseous phase.

Subsequently, the air enriched with ammonia is transferred into the adsorption column, where the removal of the ammonia from the stripping air is effected by an acidic solution, approximately 40 % ammonium sulphate, being circulated in the desorption column. The air now cleansed of ammonia is finally reused for stripping.

The condensate, which has a low ammonium content after stripping, is partially reused as service water and the remaining condensate surplus is channelled into the aerobic biological purification process. The technique is summarised in Figure 2.16.

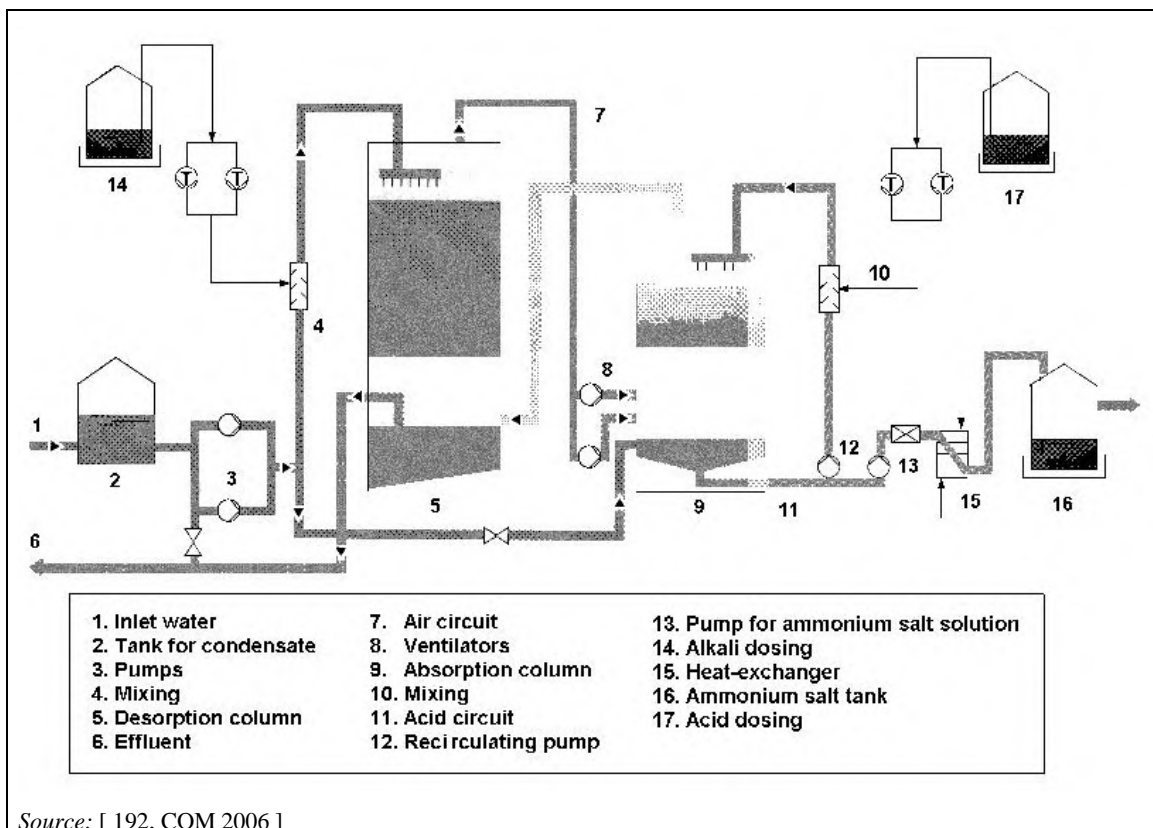

Figure 2.16: The ammonia stripping process

Achieved environmental benefits

These include reduced nitrogen emission levels. Less waste is created, i.e. the ammonium sulphate ((NH₄)₂SO₄) solution created during this process can be utilised as a liquid fertiliser or non-protein source of nitrogen for the feeding of ruminants. Cleansed water can be reused as service water, i.e. reuse of condensate, which has a low ammonium content.

Environmental performance and operational data

Ammonium concentrations of < 2 mg/l can be achieved in the outflow. This corresponds to an efficiency degree of approximately 99 %. Example design parameters for ammonia stripping from condensate generated in the sugar sector are shown in Table 2.54.

Table 2.54: Design parameters for ammonia stripping of industrial waste water (condensate) from the sugar sector

Parameter	Units	Value
Water throughput	m ³ /h	400
Ammonia concentration in the condensate	mg/l	150
Ammonium concentration in the outflow (at 55 °C)	mg/l	1.7
Air consumption	Nm ³ /h	320 000
Energy consumption	kW	300
<i>Source: [192, COM 2006]</i>		

Cross-media effects

Energy consumption is required for pouring the waste water into the adsorption columns. The condensate should be treated in the WWTP.

Technical considerations relevant to applicability

Technically, the process of ammonia stripping has proven itself for waste water streams with high ammonia concentrations.

Economics

No information provided.

Driving force for implementation

The low-ammonium-content condensate and the ammonium sulphate solution can both be reused.

Example plants

This technique has been reported in one FDM installation (#295) belonging to the dairy sector [193, TWG 2015].

Reference literature

[35, Germany 2002], [192, COM 2006], [193, TWG 2015]

2.3.6.4 Phosphorus recovery and/or removal

2.3.6.4.1 Phosphorus recovery as struvite

Description

Phosphorus is recovered by precipitation in the form of struvite (magnesium ammonium phosphate).

Technical description

In the case of waste water containing high concentrations of phosphate, phosphorus can be recovered by precipitation of struvite. The reaction takes place by adding magnesium, at pH levels of 7.5 to 10. The result will be the formation of struvite (magnesium ammonium phosphate):

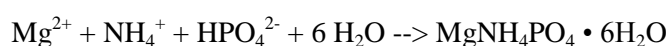

The most common technique for phosphorus recovery as struvite in the FDM sector is carried out using waste water in stirred tank reactors, after anaerobic digestion. The waste water is usually aerated in a first tank (see Figure 2.18), which results in a pH increase due to CO₂ stripping. The process continues in a second reactor (where the magnesium chloride or magnesium oxide is mixed with the waste water) and a separation unit, where struvite is removed from the waste water, dewatered and dried. Recovered struvite has a crystal structure that is pure and can be reused as a fertiliser.

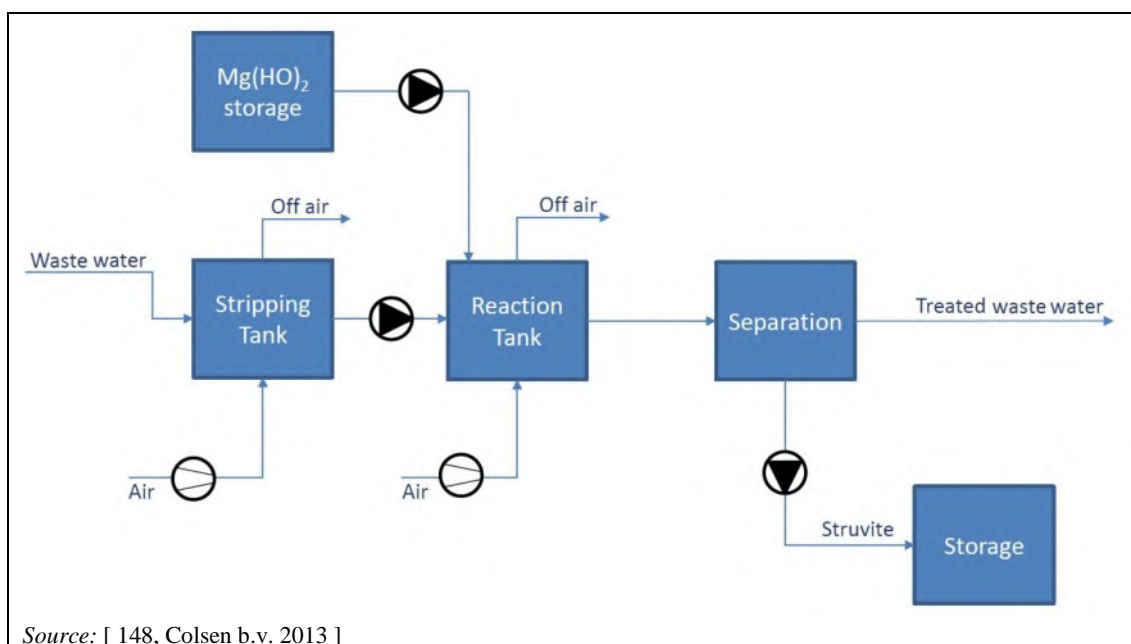

Figure 2.17: Flow diagram for one example of phosphorus recovery as struvite

In sectors other than FDM, struvite is recovered from sewage liquors or sewage sludge digestate with tens of installations operating at full scale worldwide, or from manure digestate or certain industry waste waters (semi-conductor industry, fertiliser industry, etc.). Other similar techniques exist at the development stage or operating at full scale for municipal waste waters or manures, recovering other phosphate salts (e.g. potassium struvite, brushite) or phosphoric acid which can be used in industry or converted to phosphate fertiliser products. These techniques could potentially also be used in the FDM sector [2, IED Forum 2018]. For a general description of chemical precipitation see Section 2.3.6.4.2.

Achieved environmental benefits

Reduced total phosphorus emission levels. Reduction of sludge production in the WWTP compared to chemical phosphorus precipitation. Recovery of phosphorus for other uses (e.g. as fertiliser).

The EU depends on imports for more than 90 % of its phosphorus. Phosphate rock and white phosphorus P₄ are both on the EU List of Critical Raw Materials.

Environmental performance and operational data

Struvite precipitation is carried out at full scale at several potato processing installations. For example in Belgium, the struvite recovery system was installed in the bypass between the UASB and the aerobic treatment in two potato processing installations.

In the Netherlands, a potato processing installation produces 1.8 t/day of struvite from 5 000 m³ of waste water/day; the average TP concentration is 50 mg/l in the influent, and 10 mg/l in the effluent. Another potato processing installation produces 1.1 t/day of struvite from 2 880 m³ of waste water/day; the average TP concentration is 90 mg/l in the influent, and 15 mg/l in the effluent [148, Colsen b.v. 2013].

In summary, average removal efficiencies of 80–90 % have been reported. The effluent concentration that can be reached is no lower than 10–20 mg P-PO₄/l. When phosphate is recovered from the sewage sludge directly after anaerobic digestion, the risk of scaling problems in the remainder of the sludge line can be significantly reduced.

Cross-media effects

No information provided.

Technical considerations relevant to applicability

The technique is only applicable to waste water streams with a high total phosphorus content (e.g. above 50 mg/l) and a significant flow. Potato processing installations could be suitable for phosphate recovery since their waste water contains high concentrations of phosphate. Dairy, brewery and starch manufacturing industries have less phosphorus in their waste water and therefore the operational cost to recover phosphate as struvite will be more expensive.

Economics

An investment cost of around EUR 983 000 for the treatment of 120 m³/h of waste water has been reported, for achieving an outlet P-PO₄ concentration of 20 ppm (inlet P-PO₄ concentration around 150 ppm) [193, TWG 2015]. The cost of recovery is lower compared to phosphorus removal by chemical precipitation using, for example, FeCl₃.

Phosphorus recovery as struvite can also result in a decrease in the costs for the treatment and disposal of sludge. There are potential revenues from selling the recovered struvite.

Driving force for implementation

In conventional waste water treatment plants the remaining phosphorus is mainly eliminated by chemical precipitation with metal salts. However, large amounts of chemicals are required to obtain low emission levels (1 mg/l or 2 mg/l of TP), and large volumes of sludge are produced. Furthermore, metal phosphate salts, such as iron or aluminium, cannot be reused in agriculture because the iron or aluminium phosphates are not available for plants under normal pH conditions. Due to the presence of iron or aluminium (which are added to precipitate phosphates) and the increasing contamination of waste water sludge with heavy metals and toxic organic substances, its application in agriculture has become increasingly unpopular or has been phased out completely [146, Desmidt et al. 2015].

The recovered phosphate can be reused as a fertiliser, either directly or after further processing, improving the economic feasibility of the investment. For direct use as a fertiliser, the struvite produced has to be certified and recognised. Phosphorus recovery as struvite can help to prevent scaling problems in the WWTP.

Example plants

- Three FDM installations for processing potatoes in Belgium (#031) and the Netherlands (#453 and #461) [193, TWG 2015].
- Three potato processing installations in Belgium [141, NuReSys 2016]:
 - Agristo: 750 kg struvite/day generated from 60 m³ waste water/h, start-up in 2008.
 - Clarebout potatoes (two installations): 1 800 kg struvite/day generated from 120 m³ waste water/h, start-up in 2012; 1 100 kg struvite/day generated from 80 m³ waste water/h, start-up in 2012.
- A dairy installation in Germany has had a struvite plant in operation since 2006 with a capacity of 1 580 kg struvite/day generated from 125 m³ waste water/h [141, NuReSys 2016].

Reference literature

[2, IED Forum 2018], [55, COM 2017], [141, NuReSys 2016], [146, Desmidt et al. 2015], [148, Colsen b.v. 2013], [193, TWG 2015], [228, Belgium-VITO 2015]

2.3.6.4.2 Precipitation

Description

Precipitation refers to the the conversion of dissolved pollutants into insoluble compounds by adding chemical precipitants. The solid precipitates formed are subsequently separated by sedimentation, air flotation, or filtration. Multivalent metal ions (e.g. calcium, aluminium, iron) are used for phosphorus precipitation.

Technical description

Chemical precipitation of phosphorus is a frequently utilised method of phosphorus removal that can be carried out at different stages in a biological WWTP. Phosphorus precipitation is the transformation of the soluble phosphates present in the waste water to insoluble chemical compounds (salts) followed by the removal of these insoluble precipitates by sedimentation or filtration. The most commonly utilised chemicals contain lime, aluminium (mainly alum) and iron (mainly ferric chloride).

The consumption of precipitants can be optimised by online phosphorus monitoring of the influent to the reactor [156, Belgium-VITO 2015]. For a general description of precipitation see Section 2.3.6.4.2.

Achieved environmental benefits

Reduced phosphorus emission levels.

Environmental performance and operational data

In a dairy example installation (#296), a precipitation system for phosphorus removal comprises four tanks: a softening tank, a coagulation tank (where lime is added), a flocculation tank (where microsand is added) and a settling tank with lamellae and a scraper. As the solids settle, they are transferred to the hydrocyclone which separates the microsand from the sludge. The microsand is returned to the flocculation tank to minimise loss. For a total volume of around 2 750 000 m³ of waste water in 2014, the amount of lime used was 516 tonnes; dewatering polyelectrolyte consumption was 9 000 kg and flocculating polyelectrolyte consumption was 5 000 kg. The orthophosphate load was reduced by 84 %, achieving a TP concentration of 0.36 mg/l as a yearly average [193, TWG 2015].

In another dairy installation (#406), nutrient-rich process water from the production of demineralised whey powder is routed to the phosphate removal plant (see Figure 2.17). Process water is mixed with solubilised hydrated lime to chemically combine the phosphate as Ca₅(PO₄)₃(OH) of stoichiometric composition (19 wt-% P). A coagulant (ferric chloride) is added to assist the physical separation of the calcium phosphate precipitate in a lamella separator. The calcium phosphate precipitate is dewatered in a belt press assisted by the addition

of wash water and a low concentration of flocculant (a synthetic anionic polymer). The calcium phosphate cake comprising 19 wt-% P is conveyed from the belt press to a container for export from the site as wet cake (up to 40 % dry solids) at a rate of approximately 6 tonnes per day. The nutrient-rich stream from the production of demineralised whey is approximately 460 m³/day containing approximately 360 kg/day of total phosphorus (as P). A reduction of 90 % of the total phosphorus is achieved, obtaining a TP concentration in the effluent of 1.8 mg/l as a yearly average [193, TWG 2015].

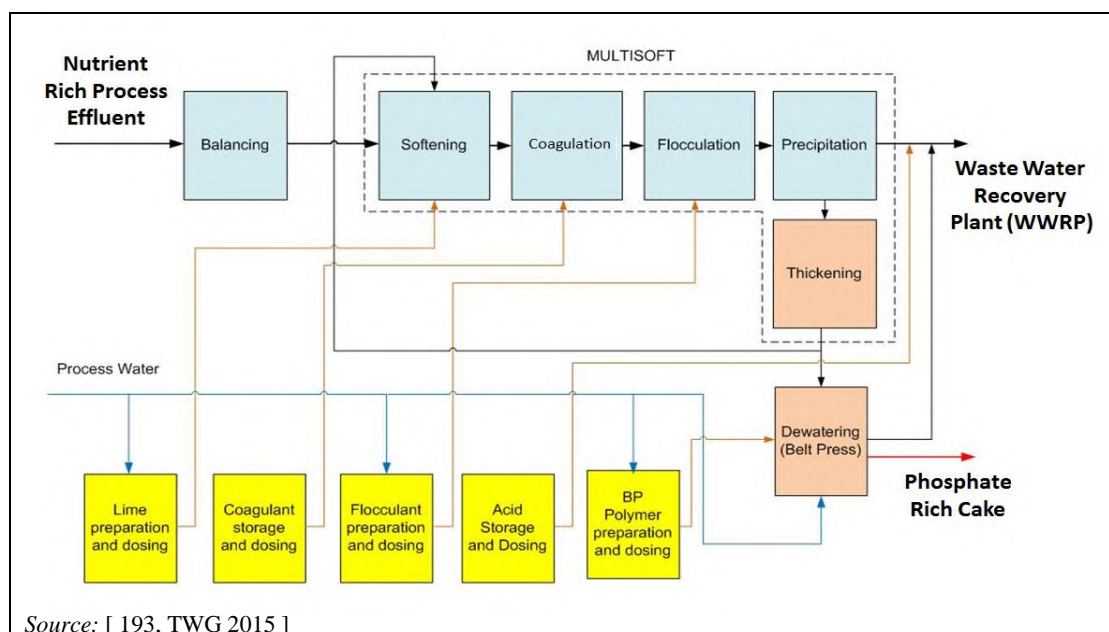

Figure 2.18: Phosphorus removal by chemical precipitation

The elimination of phosphorus from edible oil refinery waste water requires a biological waste water treatment to transform organically bound phosphorus into inorganic forms, as the former does not react with inorganic precipitants. Subsequently, precipitation by, for example, aluminium salts can achieve final emission levels of less than 4.5 g/t of unrefined oil [35, Germany 2002].

The total phosphorus emission levels from five Finnish potato starch installations with an activated sludge process and simultaneous precipitation are shown in Table 2.55.

Table 2.55: Total phosphorus emission levels from five Finnish potato starch installations with an activated sludge process and simultaneous precipitation

	Total phosphorus level (mg/l)
Influent	30–90
Effluent	1–2
NB: Activated sludge load 0.1–0.3 kg BOD/m ³ /d.	
Source: [192, COM 2006]	

Cross-media effects

Generation of sludge and consumption of chemical precipitants. Metal phosphate salts, such as iron or aluminium, might not be used as fertilisers in agriculture because the iron or aluminium phosphates are not available for plants under normal pH conditions [146, Desmidt et al. 2015].

Economics

A total cost of around EUR 2 700 000 for the phosphorus precipitation plant in an existing dairy installation processing around 100 000 t of raw materials/year and average operating costs of around EUR 0.45 per m³ of treated waste water have been reported. The cost of an online tool for monitoring total phosphorus is around EUR 15 000 [193, TWG 2015].

Technical considerations relevant to applicability

Generally, there are no technical restrictions to the applicability of this technique.

Driving force for implementation

When phosphorus removal is applied before the biological treatment, a reduction of the energy costs of the WWTP can be achieved.

Example plants

This technique is widely used in FDM installations. Example installations include #296 and #406 [193, TWG 2015].

Reference literature

[35, Germany 2002], [146, Desmidt et al. 2015], [156, Belgium-VITO 2015], [192, COM 2006], [193, TWG 2015]

2.3.6.4.3 Enhanced biological phosphorus removal

Description

A combination of aerobic and anaerobic treatment to selectively enrich polyphosphate-accumulating microorganisms in the bacterial community within the activated sludge. These microorganisms take up more phosphorus than is required for normal growth.

Technical description

FDM waste water may contain significant amounts of phosphorus if the cleaning agents used have phosphate ingredients. A total of 10–25 % of the phosphorus entering the system can be removed during primary or secondary treatment. If further removal is needed, biological treatment methods can also be used. These methods are based on stressing the microorganisms in the sludge so that they will take up more phosphorus than is required for normal cell growth. Two types of processes used for enhanced biological phosphorus removal (EBPR) are described:

- The proprietary A/O process for mainstream phosphorus removal is used for combined carbon oxidation and phosphorus removal from waste water. This process is a single-sludge suspended growth system that combines anaerobic and aerobic sections in sequence.
- In the proprietary phostrip process for side-stream phosphorus removal, a portion of the return activated sludge is diverted to an anaerobic phosphorus stripping tank.

Under certain operating conditions, more phosphorus than is needed may be taken up by the microorganisms, which is known as the luxury uptake. Under anaerobic conditions, the microorganisms break the high-energy bonds in internally accumulated polyphosphate, resulting in the release of phosphate and the consumption of organic matter in the form of volatile fatty acids (VFAs) or other easily biodegradable organic compounds. When the microorganisms are then put under aerobic conditions, they take up phosphate, forming internal polyphosphate molecules. This luxury uptake results in more phosphate being included in the cells than was released in the anaerobic zone, so the total phosphate concentration in the solution is reduced. When the microorganisms are wasted, the contained phosphate is also removed. A sufficient supply of VFAs is the key to removing phosphorus biologically [168, COM 2016].

EBPR can be accomplished in conjunction with treatment plants that nitrify and/or denitrify, with and without primary sedimentation. Where both nitrogen and phosphorus are to be removed, combined processes are used most commonly.

Achieved environmental benefits

Reduced phosphorus, BOD and TOC or COD emission levels.

Environmental performance and operational data

Phosphorus removal efficiencies of various waste water treatment methods are summarised in Table 2.56.

Table 2.56: Phosphorus removal efficiencies of various waste water treatment techniques

Waste water treatment technique	Phosphorus removal efficiency (%)
Primary treatment (see Section 2.3.6.1)	10–20
Precipitation (see Section 2.3.6.5)	70–90
Activated sludge (see Section 2.3.6.2.1.1)	10–25
Trickling filter (see Section 2.3.6.2.1.5)	8–12
RBC (see Section 2.3.6.2.1.7)	8–12
EBPR (see Section 2.3.6.4.3)	70–90
Filtration (see Section 2.3.6.5.3)	20–50
RO (see Section 2.3.6.5.4)	90–100
<i>Source: [192, COM 2006]</i>	

In the brewery #157, waste water from the anaerobic reactor is driven to a reservoir where it is mixed with aerobic sludge (from the second sedimentation) and with untreated neutralised waste water (taken before anaerobic digestion). All these flows are recirculating and, in these conditions, the aerobic sludge encourages the growth of phosphorus-assimilating bacteria. Phosphorus concentrations of around 2–3 mg/l have been reported after the application of this technique (around 80 % abatement efficiency).

EBPR is reported to be more difficult to handle than precipitation. The sludge age should be kept below 7 days. The residence time should be less than an hour.

Cross-media effects

Pumping is needed to send the waste water to further aerobic treatment.

Technical considerations relevant to applicability

Generally, there are no technical restrictions to the applicability of this technique.

Economics

An investment cost of around EUR 160 000 was reported for a waste water flow rate of 300 m³/h in a brewery. This was compensated with an annual economic saving of EUR 170 000 due to the avoidance of chemicals previously used for phosphorus precipitation [193, TWG 2015].

Driving force for implementation

To reduce the potential for eutrophication of fresh water.

Example plants

This technique has been reported in several FDM installations belonging to the brewing, fruit and vegetable, meat, starch and dairy sectors. Example installations include #024, #157 and #442 [193, TWG 2015].

Reference literature

[14, VITO et al. 2001], [78, Metcalf & Eddy 1991], [168, COM 2016], [192, COM 2006], [193, TWG 2015]

2.3.6.5 Final solids removal

2.3.6.5.1 Coagulation and flocculation

Description

Coagulation and flocculation are used to separate suspended solids from waste water and are often carried out in successive steps. Coagulation is carried out by adding coagulants with charges opposite to those of the suspended solids. Flocculation is carried out by adding polymers, so that collisions of microfloc particles cause them to bond to produce larger flocs.

Technical description

When solid particles cannot be separated by simple gravitational means, e.g. when they are too small, their density is too close to that of water or when they form colloids/emulsions, coagulation and flocculation can be used. This technique converts the substances dissolved in the water into insoluble particles by means of a chemical reaction.

This process consists of three major parts. The first stage is coagulation, which is carried out to destabilise the colloidal/emulsion system by reducing the chemical potential responsible for the system stability. This is generally undertaken by dosing with inorganic chemicals such as aluminium sulphate, ferric chloride, or lime. The next step is the flocculation of small particles into larger ones by mixing the waste water, which can be readily settled or floated. This may involve the addition of polyelectrolytes to form bridges to produce large flocs. Apart from coagulation-flocculation, some precipitation of metal hydroxides occurs and these hydroxides adsorb particles of fat. Following precipitation, sludges are removed by either sedimentation (see Section 2.3.6.5.2) or DAF (see Section 2.3.6.5.4), and before the biological treatment.

This technique may also be applied simultaneously during secondary treatment, e.g. in the activated sludge process. For instances when precipitation is applied as a tertiary treatment for phosphorus removal, see Section 2.3.6.5.

Achieved environmental benefits

Reduction of TSS, FOG and phosphorus emission levels.

Environmental performance and operational data

The effectiveness of coagulation and flocculation and selection of the coagulants depend upon understanding the interaction between the charge, size, shape and density of the particles to be separated. The final selection of the coagulant(s) should be made following thorough jar testing and plant-scale evaluation. Considerations must be given to the required effluent quality, effect on downstream treatment process performance, cost, method and cost of sludge handling and disposal, and overall net cost at the dose required for effective treatment.

Chemical treatment plants are difficult to operate as their performance is very susceptible to changing waste water characteristics so they are difficult to automate and require significant operator manpower.

Cross-media effects

Due to the addition of chemicals to the waste water, the dissolved solids/salt content may increase significantly and the solid waste produced might be difficult to reuse or dispose of. Another cross-media effect is the energy consumption for mixing.

Technical considerations relevant to applicability

Generally, there are no technical restrictions to the applicability of this technique.

Economics

This technique produces solid waste which is expensive to dispose of.

Driving force for implementation

No information provided.

Example plants

The technique has been applied in several installations of the following FDM sectors: dairy, oilseed processing and refining, brewing, sugar manufacturing, starch production and fruit and vegetables [193, TWG 2015].

Reference literature

[35, Germany 2002], [109, Finland 2003], [193, TWG 2015]

2.3.6.5.2 Sedimentation**Description**

The separation of suspended particles by gravitational settling.

Technical description

A detailed technical description of sedimentation can be found in the CWW BREF [168, COM 2016].

Achieved environmental benefits

These include reduction of TSS emission levels. The sludges generated might be recoverable as a by-product, e.g. for possible animal feed. TSS can also include particulate organics, i.e. sedimentation will reduce TOC or COD, TN and TP emission levels as well, as long as they are present as insoluble solid material. Its removal efficiency, however, depends on the proportion of solid TOC in the overall TOC.

Environmental performance and operational data

It has been reported that in the fish sector up to 35 % of the solids present can be removed by sedimentation. Table 2.57 shows the typical performance data of the brewery sector after sedimentation.

Table 2.57: Typical performance data of the brewery sector after sedimentation

Initial load (m³/m²/h)	Final TSS (mg/l)
0.5–1.0	20–30
NB: The acceptable loading will depend on the sedimentation characteristics of the sludge. Source: [72, Brewers Europe 2002]	

The advantages and disadvantages of sedimentation are shown in Table 2.58.

Table 2.58: Advantages and disadvantages of sedimentation

Advantages	Disadvantages
Simplicity of installation, not liable to fail	Rectangular or circular tanks may occupy large surface areas
	Unsuitable for finely dispersed material
	Laminar separators may be prone to blockage with fat
Source: [192, COM 2006]	

In the sugar sector, the fluming or transport water contains mud, stones and waste vegetation, as well as high COD from damaged sugar beet. The heavy dust requires sedimentation. The use of large sedimentation ponds has been reported. The sludge taken from the settlement ponds can be further dewatered and the liquors recovered from the dewatering process can be returned to the factory, either via the diffusers or as fluming water.

An average of approximately 11 % of the incoming phosphorus load is removed with the primary sludge during primary sedimentation [146, Desmidt et al. 2015].

Cross-media effects

Sedimented sludge, if not suitable to recycle or reuse, needs to be disposed of as waste. Sources of noise are the pumps, which can be enclosed, and the sludge/scum removal system. When the waste water contains odorous substances, it might be necessary to cover the sedimentation tank, and to duct the arising waste gas, if necessary, to a treatment system.

Technical considerations relevant to applicability

Generally, there are no technical restrictions to the applicability of this technique.

Economics

Waste water treatment charges generally make it cost-effective for most installations covered by the IED to carry out some sort of separation of TSS. Compared to DAF, sedimentation has higher capital costs but lower operating costs.

Driving force for implementation

No information provided.

Example plants

Widely used in FDM installations [193, TWG 2015].

Reference literature

[8, Environment Agency of England and Wales 2000], [35, Germany 2002], [72, Brewers Europe 2002], [146, Desmidt et al. 2015], [168, COM 2016], [193, TWG 2015]

2.3.6.5.3 Filtration

Description

The separation of solids from waste water by passing them through a porous medium, e.g. sand filtration, microfiltration and ultrafiltration.

Technical description

Unlike sedimentation (see Section 2.3.6.5.2) or DAF (see Section 2.3.6.5.4), filtration does not require any difference in density between the particles and liquid. The separation of particles and liquid is brought about by a pressure difference between the two sides of the filter, allowing the passage of water through the filter. Thus, the particles are held back by the filter medium. A detailed technical description of filtration can be found in the CWW BREF [168, COM 2016]. Information on membrane filtration is specifically given in Section 2.3.6.5.4.

Achieved environmental benefits

Reduced emission levels of TSS.

Environmental performance and operational data

In the brewing sector, the use of sand filters to comply with waste water requirements more stringent than 15 mg/l of BOD and 20–30 mg/l of TSS has been reported. Sand filters are used to remove TSS, as the soluble BOD is very low after extended aerobic treatment. Phosphorus removal efficiencies of 20–50 % have been reported using filtration.

Cross-media effects

No information provided.

Technical considerations relevant to applicability

Applicable in all FDM installations.

Economics

No information provided.

Driving force for implementation

The driving force for implementation is to reduce the amount of suspended solids in the final waste water effluents and to meet the legal discharge standards. If filtration is used for sludge treatment purposes, the driving force for implementation is to reduce the water content and subsequent volume of the sludge produced.

Example plants

This technique has been reported in several FDM installations belonging to the brewing, dairy, soft drinks, oilseed, meat and fruit and vegetable sectors [193, TWG 2015].

Reference literature

[1, CIAA 2002], [8, Environment Agency of England and Wales 2000], [35, Germany 2002], [72, Brewers Europe 2002], [168, COM 2016], [193, TWG 2015]

2.3.6.5.4 Flotation**Description**

The separation of solid or liquid particles from waste water by attaching them to fine gas bubbles, usually air. The buoyant particles accumulate at the water surface and are collected with skimmers.

Technical description

The separation of materials lighter than water, e.g. edible oil/fat, can be enhanced by using flotation. This technique decreases the retention time but does not enable the separation of emulsified FOG from water and, therefore, is used widely in the FDM sector for the removal of free FOG.

The basic mechanism of flotation, also known as dissolved air flotation (DAF), is the introduction of small air bubbles into the waste water containing the suspended solids to be floated. The fine air bubbles attach themselves to the chemically conditioned particles and, as they rise to the surface, the solids float to the surface with them.

The air is dissolved under pressure, i.e. at 300–600 kPa (3–6 bar). The air is normally introduced into a recycle stream of treated waste water which has already passed through a DAF unit. This supersaturated mixture of air and waste water flows to a large flotation tank where the pressure is released, thereby generating numerous small air bubbles. Here they are accumulated, thickened and removed by mechanical skimming or suction withdrawal. Chemicals such as polymers, aluminium sulphate or ferric chloride can be used to enhance flocculation and, therefore, the adhesion of bubbles. DAF equipment is similar to that used for sedimentation (see Section 2.3.6.5.2).

Achieved environmental benefits

Free FOG, BOD/COD, TSS, nitrogen and phosphorus emission levels are reduced. The sludge can also be used for biogas production. The system is kept aerobic, so the risk of odour problems is low.

Environmental performance and operational data

DAF units have been somewhat successful in the treatment of seafood processing waste water. When used without coagulants and flocculants, DAF units can remove up to 50 % of suspended solids and 80 % of FOG. Addition of coagulants and flocculants can increase separation efficiencies to between 80 % and 95 %. Removal of COD/TOC and BOD depends on the amount of dissolved materials and separation efficiencies can vary between 15 % and 65 %. When chemicals are used to improve removal of fat and oil to meet strict environmental regulations, the recovery of fat and oil is not easy to achieve. DAF units used in treatment of seafood processing waste water are usually operated at around pH 5 to minimise protein solubility [205, Nordic Council of Ministers 2015].

During DAF, the pressurisation system may be prone to blockage problems. Typically, sludges recovered from a DAF cell would be in the region of 3–4 % dry solids content. For the sludges to be recovered, coagulants and flocculants either have to be avoided or suitable substances chosen.

Cross-media effects

The technique requires energy consumption for compressed air and, depending on the amount of protein in the waste water, addition of flocculant.

Technical considerations relevant to applicability

Generally, there are no technical restrictions to the applicability of this technique.

Economics

Compared to sedimentation, DAF has lower capital costs but higher operating costs.

Driving force for implementation

- It is beneficial to reduce TSS in the discharge in order to reduce the cost of charges for downstream waste water treatment.
- Compared to sedimentation, DAF requires less land, has a higher separation efficiency and can to some extent absorb shock loads.

Example plants

The technique is widely used in FDM installations [193, TWG 2015].

Reference literature

[8, Environment Agency of England and Wales 2000], [13, Nordic Council of Ministers 1997], [35, Germany 2002], [193, TWG 2015], [205, Nordic Council of Ministers 2015], [226, EDA 2016]

2.3.6.5.5 Membrane filtration

Description

Use of a pressure-driven semi-permeable membrane (e.g. ultrafiltration, reverse osmosis) to achieve selective separation of substances.

Technical description

Membrane filtration processes use a pressure-driven semi-permeable membrane to achieve selective separation of substances in waste water. Much of the selectivity is established by designations relative to pore size. The pore size of the membrane is relatively large if precipitates or suspended materials are being removed or very small for the removal of inorganic salts or organic molecules. During operation, the feed solution flows across the surface of the membrane, clean water permeates through the membrane, and the contaminants and a portion of the feed remain in the solution. The clean or treated waste water is referred to as the permeate or product water stream, while the stream containing the contaminants is called the concentrate, brine or reject. An example of a membrane unit is shown in Figure 2.19.

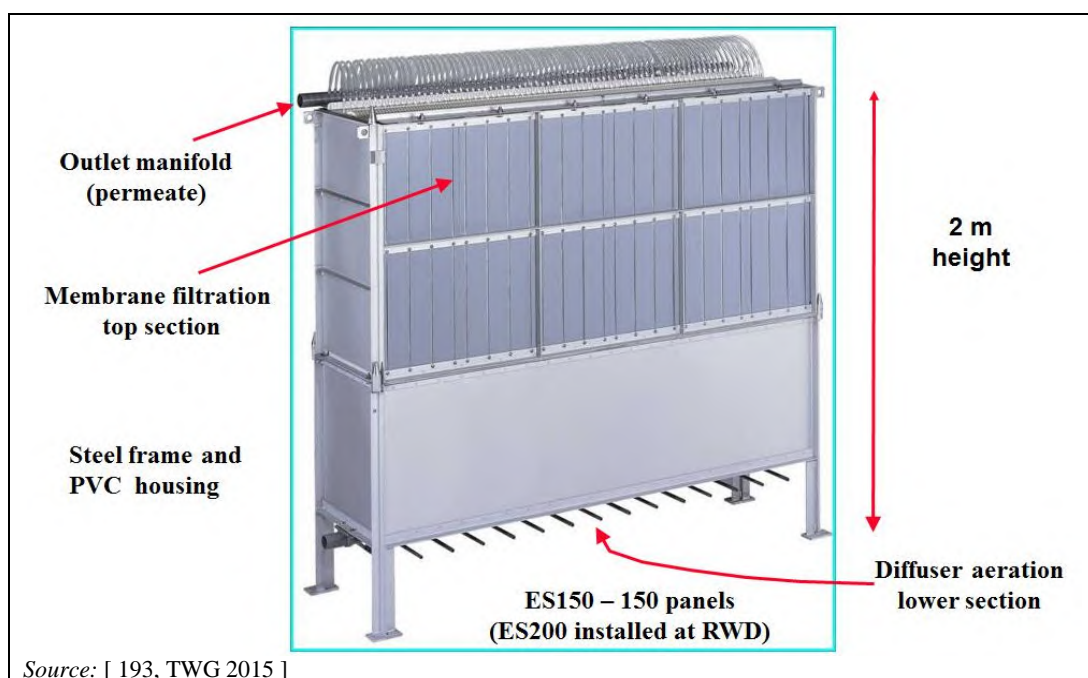

Figure 2.19: Example of a membrane unit implemented in a dairy

For the cases when membrane filtration is combined with a biological waste water treatment, see the membrane bioreactor technique (MBR) in Section 2.3.6.2.3.1.

Ultrafiltration (UF) membranes have small pores, 0.001–0.02 μm . The smallest pore size UF membrane has the capacity to reject molecules with diameters greater than 1 nm or nominal molecular weights greater than 2 000 atomic mass units. Some primary treatment may be necessary to prevent membrane fouling. For most UF designs, the introduction of adsorbents or flocculants to the feed stream is not recommended since they may plug the membrane module. Applications of UF include the removal of oil from waste water and the removal of turbidity from colour colloids.

Reverse osmosis filtration (RO) has the ability to reject dissolved organic and inorganic molecules. Water is separated from dissolved salts by filtering through a semi-permeable membrane at a pressure greater than the osmotic pressure caused by the salts. The advantage of RO is that dissolved organics are less selectively separated than in other processes. The purified solution permeates through the membrane.

Nanofiltration (NF) is a relatively new technique combining features of UF and RO with a high selectivity. Its name is derived from its approximate cut-off size of some nanometres or, more exactly, molar masses of 200–1 000 g/mol. This is achieved with special nanofiltration membranes which still have pores of a defined size, but their retention depends on the electrostatic charge of the molecules to be separated. The membranes have selective permeability for minerals, i.e. high permeability for monovalent cations and anions and lower permeability for bivalent cations. Nanofiltration systems are operated at medium pressures in the range of 1–5 MPa.

Electrolysis enables ionic separation by using an electrical field as a driving force as opposed to a hydraulic force. The membranes used are adapted to make them ion-selective (for cations and anions). A number of cells are required to make up the complete electrolysis unit. Chemical precipitation of salts on the membrane surface and clogging by the residual organic colloids can be prevented by pretreating the waste water with activated carbon, or chemical precipitation or by some sort of multimedia filtration.

Cross-flow filtration is in some cases an alternative to dead-end filtration. Cross-flow filtration is filtration where the flow is parallel to the membrane surface. The whole flow needs to be brought under pressure. The principle is shown in Figure 2.20. The feed stream does not require extensive primary treatment, while the membrane is relatively resistant to fouling and can be easily cleaned. This technique is applicable for removing bacteria and contaminants from feed streams, but not for effective pesticide treatment unless the active ingredients are relatively insoluble or attached to the suspended material. Cross-flow filtration has a high energy consumption because all the water is put under pressure. It is applied in breweries, wineries, dairies and WWTPs [8, Environment Agency of England and Wales 2000], [11, Envirowise (UK) 1998], [142, Ellis L. 2002].

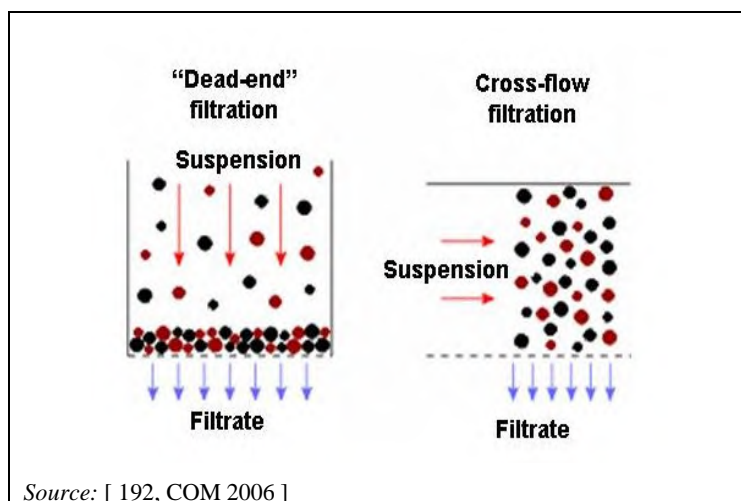

Figure 2.20: The principle of cross-flow filtration, compared to dead-end filtration

Achieved environmental benefits

Suspended, colloidal and dissolved solids emission levels are reduced. Phosphorus emission levels can be reduced, i.e. using RO. The implementation of this technique can also lead to:

- concentration of waste water streams to reduce volumes prior to further treatment/disposal, e.g. possible concentration of dilute waste to concentrations suitable for reuse;
- recovery of expensive ingredients for reuse or return/sale to suppliers on site or elsewhere;
- recovery of water for reuse.

Environmental performance and operational data

Problems may arise from the fouling of membranes and gel polarisation. Since the flux rates through membranes are relatively low, an extensive membrane area is required to recover material.

Using UF, up to 90–95 % of the feed can be recovered as product water. Phosphorus removal efficiencies of 90–100 % have been reported using RO.

RO membranes are very susceptible to fouling and may require an extensive degree of primary treatment. In a starch installation (#419), the removal of naturally occurring bacteria within the borehole water greatly reduced the life cycle of the filters within the RO plant dedicated to purifying water before using it in a cooling water circuit [193, TWG 2015]. Oxidants which may attack the membrane and particulates, e.g. oil, grease and other materials which may cause a film or scale to form, should be removed by primary treatment or the membrane will need to be subjected to frequent cleaning cycles. RO product streams are normally of very high quality and suitable for reuse in the manufacturing process. Standard practice is to dispose of the reject

stream or to apply a suitable treatment to the concentrated brine. The recovery that can be achieved, as well as the operating pressure required, will depend on the type of dissolved solids and their concentrations. RO has been used to remove heavy metals and pesticides whose active ingredient molecular weights are greater than 200 atomic mass units.

Cross-media effects

Additional waste water may be produced. Use of chemicals for cleaning the membranes.

Technical considerations relevant to applicability

Generally, there are no technical restrictions to the applicability of this technique.

Economics

The operating cost associated with the use and cleaning of membranes can be very high. There are also high energy costs.

A total cost of around EUR 3 600 000 has been reported for the installation of a RO plant in a dairy, for recycling about 130 000 m³ waste water/year [193, TWG 2015].

Driving force for implementation

No information provided.

Example plants

This technique has been reported in several FDM installations belonging to the brewing, dairy, oilseed and fruit and vegetable sectors [193, TWG 2015].

Reference literature

[8, Environment Agency of England and Wales 2000], [11, Envirowise (UK) 1998], [51, Ullmann 2001], [71, AWARENET 2002], [78, Metcalf & Eddy 1991], [142, Ellis L. 2002], [192, COM 2006], [193, TWG 2015]

2.3.6.5.6 UV radiation

Description

UV light is readily absorbed by the cellular genetic material within bacteria and viruses, and prevents the cell from replicating.

Technical description

UV light at 254 nm is readily absorbed by the cellular genetic material within bacteria and viruses, and prevents the cell from replicating. The dose rate is measured in milliwatts per square centimetre multiplied by the contact time in seconds. The actual dose depends on the transmittance, i.e. related to the presence of other compounds which can absorb and reduce UV light effectiveness, of the waste water stream.

Achieved environmental benefits

There is no residual effect that can be harmful to humans or aquatic life.

Environmental performance and operational data

The main advantages of UV disinfection over the other techniques include the fact that there is no need for storage and no need for the use of chemicals, and the absence of harmful by-products (e.g. organic halogenated substances). On the other hand, the main disadvantage of UV disinfection is that a direct line of sight should be maintained between the lamp and the bacteria/virus. Any appreciable levels of suspended solids or turbidity (which decrease the transmittivity) will shield the bacteria and prevent their disinfection. Waste water containing compounds with high transmittance values require higher doses of UV radiation. UV radiation is unstable and should be generated as used.

Cross-media effects

Energy consumption is required to generate UV waves. Water treated by UV radiation is liable to reinfection, so it needs to be used quickly and hygienically.

Technical considerations relevant to applicability

Applicable in all FDM installations.

Economics

Relatively low capital and operating costs.

Driving force for implementation

- Waste water recycling, even as drinking water.
- No need for use of chemicals.

Example plants

This technique has been reported in two FDM installations belonging to the brewing (#079) and dairy (#406) sectors [193, TWG 2015].

Reference literature

[1, CIAA 2002], [8, Environment Agency of England and Wales 2000], [71, AWARENET 2002], [193, TWG 2015]

2.3.6.6 Natural treatment

2.3.6.6.1 Integrated constructed wetlands

Description

Interconnected basins or lagoons planted with a wide variety of aquatic plant species, allowing subsequent waste water treatments.

Technical description

ICW are distinguished from other constructed wetland techniques on the basis that they are designed to facilitate the widest possible range of ecological conditions, as found in natural wetlands, including those of soil, water, plant and animal ecology. In addition, the ICW concept strives to achieve landscape fit and habitat restoration/creation into its designs. Emphasis is placed on monitoring water quality within the wetlands and the surrounding land and watercourses. Strategically located monitoring wells are also monitored regularly.

The ICW design simultaneously applies primary, secondary and subsequent levels of treatment in its free surface water flow. This is achieved by the construction of a series of shallow interconnected basins or lagoons planted with a wide variety of aquatic plant species. The waste water is introduced at the highest point in these lagoons and is fed by gravity through the lagoons. These sequentially arranged lagoons are self-contained individual ecosystems. With each step, a cleaner level of waste water is attained. The relationship of the volume of waste water to the area of wetland in the overall ICW design determines the outflowing water quality.

The macrophytic vegetation used in the ICW design performs a variety of functions. Its primary function is the support of biofilms (slime layers), which carry out the principal cleansing functions of the wetland. It also facilitates the sorption of nutrients and acts as a filter medium, and, through the use of appropriate emergent vegetation, can control odours and pathogens. While the vegetation has the capacity to filter suspended solids, it also increases the hydraulic resistance, thus increasing the residence time.

Achieved environmental benefits

TSS, BOD and TOC or COD, nitrogen and phosphorus emission levels are reduced. Energy is saved, compared to conventional treatment. Greenhouse gas emissions are reduced. No chemicals are used. No sludge disposal is required.

Environmental performance and operational data

An example dairy installation in Ireland produces 85 tonnes of cheese per day from 800 000 litres of milk and generates up to 1 300 m³ of waste water. The installation has an ICW comprising 8 hectares of lagoons occupying 20 hectares which treat 1.1 million litres of waste water per day. The waste water is pumped to the wetland about half a mile from the dairy and fed in at the highest point. The system of lagoons progresses downwards along the contours of the land and the treatment is achieved progressively as the waste water passes through the system. Performance levels from this ICW are shown in Table 2.59.

Table 2.59: Performance levels reported for an ICW

Sample point	COD (mg/l)	Total P (mg/l)	Ammonia (mg/l)	Nitrate (mg/l)
Influent waste water	3 167	212	12	102
Final monitoring pond	36.5	0.5	0.05	< 1
<i>Source: [112, Ireland 2003]</i>				

In another example dairy (#388), a constructed wetland area with the capacity for 600 m³/day is used for the treatment of lightly contaminated waste water with a maximum influent BOD concentration of 100 mg/l. Regarding the effluent of the ICW, the average COD concentration is in the range of 75.6–108.9 mg/l, the average TN concentration in the range of 39.3–53.3 mg/l, and the average TP concentration in the range of 0.4–1.0 mg/l. Only a little electricity is used for cleaning the water and no chemicals are required [193, TWG 2015].

Cross-media effects

The groundwater that flows beneath the wetlands has lower nutrient levels than surrounding terrestrial sites. Phosphorus is retained in the soil. An ICW can provide suitable effluent to be used for irrigation of crops and pasture.

Technical considerations relevant to applicability

The ICW technique can be applied in a wide range of circumstances, e.g. high or low concentrations of contaminants and hydraulic loading rates that may vary over time. ICW may be built as an entirely new entity or may form part of an existing wetland, aquatic landscape feature or WWTP. The land requirement associated with ICW can restrict their application, e.g. land requirements can range from 10 m² to many hectares depending on the volume of waste water produced and its pollution characteristics.

Economics

It has been reported that, compared to a conventional WWTP, the ICW approach allows a saving on operational, depreciation and capital costs of EUR 0.03, EUR 0.49 and EUR 0.46 per kg of COD, respectively. The reduction is mainly due to the reduced energy costs, lack of chemical usage, lack of sludge production and storage.

The example dairy installation in Ireland reported that its ICW system cost EUR 120 000, which is comparable to EUR 3.175 million reported for a conventional WWTP [112, Ireland 2003].

Driving force for implementation

- Economic savings.
- ICW provide a habitat for a wide variety of plants and animals. They may be a local amenity and educational resource.
- The recovered biomass can have a wide range of applications (e.g. substrate for biogas or bioethanol production).

Example plants

This technique has been reported in one dairy installation (#388) in Sweden [193, TWG 2015].

Reference literature

[91, Giner Santonja et al. 2017], [112, Ireland 2003], [193, TWG 2015]

2.3.6.7 Sludge and waste treatment

2.3.6.7.1.1 Sludge conditioning

Description

Sludge solids are treated with chemicals or various other means to prepare the sludge for dewatering processes, in other words, to improve dewatering characteristics of the sludge.

Technical description

The purpose of conditioning is to improve the characteristics of the sludge so that it is easier to thicken and/or dewater. The techniques generally used are chemical or thermal. Chemical conditioning (using for example ferric chloride, lime, alum and organic polymers (coagulants and flocculants)) assists in the separation of the bound and entrained water from within the sludge. Thermal conditioning involves heating the sludge under pressure for short periods of time.

Achieved environmental benefits

Reduction of odorous constituents. Reduction of the quantity of biodegradable sludge solids. Reduction of the quantity of biodegradable soluble matter, by converting mineralised nitrogen/organic matter into humus-rich material. Reduction of pathogens. Reduction of potential for putrefaction. Improved dewatering.

Environmental performance and operational data

No information provided.

Cross-media effects

Chemical conditioning results in a considerable rise in the solids content to be disposed of.

Technical considerations relevant to applicability

No information provided.

Economics

Associated chemical costs are generally high.

Driving force for implementation

No information provided.

Example plants

Conditioning of sludge is widely applied in Europe.

Reference literature

[78, Metcalf & Eddy 1991], [168, COM 2016], [193, TWG 2015]

2.3.6.7.1.2 Sludge stabilisation

Description

Chemical or biological process that stops the natural fermentation of the sludge.

Technical description

Sludges are stabilised by chemical, thermal, anaerobic and aerobic processes to improve sludge thickening and/or dewatering and reduce odour and pathogens. A detailed technical description of sludge stabilisation can be found in the CWW BREF [168, COM 2016].

Achieved environmental benefits

Reduction of odorous constituents. Reduction of the quantity of biodegradable sludge solids. Reduction of the quantity of biodegradable soluble matter, by converting mineralised nitrogen/organic matter into humus-rich material. Reduction of pathogens. Reduction of potential for putrefaction. Improved dewatering.

Environmental performance and operational data

A chemical stabilisation process has low technical requirements and can improve downstream dewatering and reduce odours and pathogens. Nevertheless, it increases the solids content of the sludge.

A thermal stabilisation process has low space requirements and is an effective treatment for dewatering sludge and destroying bacteria. Its selection can depend on whether the heat is natural, recovered as a by-product of the processes operating in the installation or whether direct energy consumption is required.

An aerobic stabilisation process has a long residence time, produces odourless sludge and produces gas, which is a source of energy. Nevertheless, the process is significantly affected by temperature and the sludge has poor mechanical dewatering characteristics.

Cross-media effects

Thermal stabilisation has high energy requirements and may release odours. Aerobic stabilisation also has high energy requirements for stirring and the supply of oxygen. Because lime (chemical) stabilisation does not destroy the organics necessary for bacterial growth, the sludge must be treated with an excess of lime or disposed of before the pH drops significantly.

Technical considerations relevant to applicability

Applicable in all FDM installations that produce sludge.

Economics

Thermal and anaerobic stabilisation have high capital costs. Aerobic stabilisation has low capital costs.

Driving force for implementation

To reduce odorous emissions and improve subsequent treatment operations.

Example plants

Stabilisation of sludge is widely applied in Europe.

Reference literature

[1, CIAA 2002], [8, Environment Agency of England and Wales 2000], [35, Germany 2002], [78, Metcalf & Eddy 1991], [168, COM 2016], [193, TWG 2015]

2.3.6.7.1.3 Sludge thickening

Description

The solids content of sludge is increased by removing a portion of the liquid fraction.

Technical description

Thickening is a procedure used to increase the solids content of sludge by removing a portion of the liquid fraction. The techniques generally used for sludge thickening are sedimentation, centrifugation and DAF. The simplest thickening technique is to allow the sludge to consolidate in sludge sedimentation tanks.

Sludge thickening can be applicable to both primary and secondary treatment sludge. Primary treatment sludge consists mainly of inorganic material and/or primary organic solids. It is generally able to settle and compact without chemical supplementation, as associated water is not excessively entrained within the sludge. The water in secondary treatment sludge is bound within the flocs and is generally more difficult to remove.

Achieved environmental benefits

Sludge volume reduction.

Environmental performance and operational data

Sludges that are taken from the bottom of primary and secondary sedimentation tanks will generally be around 0.5–1.0 % dry solids content and up to 4 % dry solids for DAF sludges. When using DAF, the system is kept aerobic. In this case, blockage has been reported.

The thickening efficiency of the sedimentation process is affected by the height of the sludge layer and not by the volume of the supernatant above it. Therefore, a tall, narrow tank is more effective than a shallow tank with a large surface area. This technique has a low energy consumption.

Depending upon the pattern of primary sludge removal, consideration can be given to the use of two tanks to allow for quiescent sedimentation in one tank whilst the other is in the fill cycle. If this is not possible, the sludge inlet is arranged to be near the top of the tank, possibly onto a baffle plate, to minimise hydraulic disturbance. Residence time within the tank will depend on the nature of the sludges. Excessive retention is avoided to minimise the possibility of anaerobic conditions occurring with consequent odour and corrosion problems.

Gentle agitation is allowed for within the tank. A picket fence thickener within the tank is most commonly used, to help reduce stratification of the sludge and to assist in the release of any entrained gases and water. A conventional gravity/picket fence thickener is capable of thickening the sludge up to 4–8 % dry solids, depending on the nature of the raw sludge and in particular on the relative content of primary sludge. Addition rates to the thickener are in the range of 20–30 m³ of feed per m² of surface area per day.

Centrifugation provides a good capture of solids that are difficult to filter, has low space requirements and is easy to install, but it achieves a low solids concentration in the cake. It has a high energy consumption and requires skilled maintenance personnel.

For many sites, sludge thickening alone is sufficient to reduce the volume of sludge to a level that enables off-site disposal to be undertaken in a sufficiently cost-effective manner. For larger sites, the thickening process is a first stage prior to further dewatering.

Cross-media effects

Possible release of odour when using DAF. High energy consumption and noise and vibration generation when using centrifugation.

Technical considerations relevant to applicability

Applicable to all FDM installations that produce sludge.

Economics

Reduction of pumping costs in large WWTPs. Sedimentation thickening has low operational costs.

Driving force for implementation

Reduction of pipe size and pumping costs in large WWTPs.

Example plants

This technique is widely applied in Europe.

Reference literature

[1, CIAA 2002], [8, Environment Agency of England and Wales 2000], [35, Germany 2002], [78, Metcalf & Eddy 1991], [193, TWG 2015]

2.3.6.7.1.4 Sludge dewatering

Description

Separation of sludge into liquid and solid components.

Technical description

The objective of sludge dewatering is the same as that of thickening (see Section 2.3.6.7.1.3) with the difference that the solid content is much higher. A number of sludge dewatering processes exist and selection will depend upon the nature of the solids produced and the frequency of their production, and the sludge cake required. The dewatering techniques generally used are centrifugation, belt filter press, filter press and vacuum filters.

Achieved environmental benefits

Sludge volume reduction.

Environmental performance and operational data

Centrifuges are continuous processes which produce a cake of up to 40 % dry solids for certain sludges. Because of the closed nature of the centrifuge, associated odour problems are minimal. Furthermore, centrifugation provides a good capture of solids that are difficult to filter, has low space requirements and is easy to install. Nevertheless, this process needs high energy consumption, achieves a low solids concentration in the cake and requires skilled maintenance personnel.

Filter presses are batch processes and can be manually intensive. The plates are covered with a suitable filter cloth, dependent upon the application, and the sludge is fed into the plate cavity. The sludge is dewatered under pressure with the filtrate passing through the filter cloth. Once the pressure is released and the plates separated, the cake is either manually scraped off or vibration mechanisms are employed to automate the process. A filter press can produce up to 40 % dry solids cake and attain a filtrate with low TSS. The disadvantages of using this technique are that it is essentially a batch operation and that it has a limited filter cloth life.

Floccing agents (e.g. powder) are also normally used. For instance, consumption of around 4 500 kg/year has been reported for the fruit and vegetable processing installation #035, when applying centrifugation and obtaining 7 600 m³/year of recycled water. The efficiency of the process partially depends on the quality of the floccing agent used [193, TWG 2015].

The belt press and vacuum filters are continuous processes with the filter cloth continually running through rollers that forcefully dewater the sludge. Performance optimisation requires regular and specialised maintenance.

A belt press can produce up to 35 % dry solids cake. Furthermore, belt presses have a high dewatering efficiency and are relatively easy to maintain. Disadvantages of using them include hydraulic limitations, a short life and sensitivity to sludge feed characteristics.

The vacuum filters are complex systems with a maximum differential pressure of 1 bar. The filtrate may have high TSS.

Cross-media effects

High energy use, and noise and vibration generation when using centrifugation, although this varies depending on the speed and intensity of the individual operation.

Technical considerations relevant to applicability

Applicable to all FDM installations that produce sludge.

Economics

Sludge with over 10 % dry solids becomes difficult and expensive to pump. Dewatering produces a sludge cake, which may be between 20 % and 50 % dry solids. Disposal costs fall as

the water content is reduced. Filter presses have high labour costs. Vacuum filters have high operating and maintenance costs.

An investment cost of EUR 120 000 and annual operating cost of EUR 38 000 have been reported in an installation applying centrifugal dewatering to approximately 5 000 t of sludge/year, with annual savings of EUR 88 000 due to the reduced sludge transport costs [193, TWG 2015].

Driving force for implementation

Reduction of disposal costs.

Example plants

This technique is widely applied in Europe.

Reference literature

[1, CIAA 2002], [35, Germany 2002], [109, Finland 2003], [193, TWG 2015]

2.3.6.7.1.5 Sludge drying

Description

Reduction of water content in sludge by vaporisation of water to the air.

Technical description

Sludge drying is a technique that involves reducing the water content by vaporisation of water to the air. The purpose of drying is to remove the moisture from the wet sludge so that it can be used or disposed of efficiently.

Achieved environmental benefits

Sludge volume reduction.

Environmental performance and operational data

The moisture content of the dry sludge can be as low as 10 %. Drying can be achieved by using natural evaporation, where the local weather and climate conditions make this possible, by recovery of heat produced in the installation or by using an off-site energy source.

Cross-media effects

High energy consumption when using an off-site energy source.

Technical considerations relevant to applicability

Applicable to all FDM installations that produce sludge.

Economics

No information provided.

Driving force for implementation

Reduction of disposal costs.

Example plants

This technique has been reported in installations belonging to the brewing, dairy, fruit and vegetable, and starch sector [193, TWG 2015].

Reference literature

[78, Metcalf & Eddy 1991], [193, TWG 2015]

2.3.6.8 Analysis of key parameters

This section discusses the reported performance of the 353 FDM installations (see Table 19.1) for a number of parameters. The graphs contained in this section refer to waste water discharged (direct discharge) from FDM installations. Influent and effluent data were gathered for the reference years 2012 to 2014. In general, the most recent dataset of each point of release is displayed except for some questionnaires where an earlier year contains a more complete set of data and no significant differences in terms of the emission levels were observed.

Separate graphs have been prepared for the following parameters: biochemical oxygen demand in five days (BOD₅), chemical oxygen demand (COD), total organic carbon (TOC), total suspended solids (TSS), total nitrogen (TN), ammonium nitrogen (NH₄-N), total phosphorus (TP), and chloride (Cl).

Concentration and specific load values are shown in separate graphs. The symbols used in this section are given in Table 2.60. The abbreviations used in this section are given in Table 2.61 and Table 2.62.

Table 2.60: Symbols used in the graphs of Section 2.3.6.8







Symbol	Meaning	Type of monitoring regime
	Average of the emission levels over the period 2012-2014	Frequent monitoring (at least 1 measurement per month) – campaign period
		Frequent monitoring (at least 1 measurement per month) – non-campaign period
		Less frequent monitoring (less than 12 measurements per year) – campaign period
		Less frequent monitoring (less than 12 measurements per year) – non-campaign period
	95 th percentile of the emission levels for each reported year	-
	Maximum/minimum of the emission levels over the period 2012-2014	Campaign period
		Non-campaign period

Table 2.61: Abbreviations used in the graphs of Section 2.3.6.8 (1 of 2)

Abbreviations used in graphs	Waste water treatment technique
Aero	Aerobic biological treatment
Anaer	Anaerobic biological treatment
An+aer	Aerobic and anaerobic biological treatment
Enh	Enhanced phosphorus removal
Flot	Flotation
Ni+De	Nitrification/denitrification
NI	No information provided
NT	No treatment
PC	Physico-chemical treatment
Prec	Precipitation
Sed	Sedimentation
Str	Phosphorus recovery as struvite

Table 2.62: Abbreviations used in the graphs of Section 2.3.6.8 (2 of 2)

Abbreviation used in graphs	Sector covered by the FDM data collection
AN	Animal feed
BR	Brewing
DA	Dairies
FR	Fruit and vegetables
ET	Ethanol production
ME	Meat processing
OI	Oilseed processing and vegetable oil refining
SO	Soft drinks and nectar/juice made from concentrate
ST	Starch production
SU	Sugar manufacturing

Waste water treatment is usually a combination of individual treatment steps. The most commonly used activated sludge process is generally preceded and followed by a solids removal step. The activated sludge process may be combined with biological nitrification and denitrification, and/or chemical phosphorus precipitation depending on the composition of the waste water. Other installations do not implement a biological treatment, only a physico-chemical one.

In the following graphs, each average effluent value (with the exception of the graphs on total suspended solids) is also labelled with 'Bio' or 'PC' to indicate whether the waste water treatment is biological (Bio) or only physico-chemical (PC). When there is no information provided about the techniques implemented, the label 'NI' is shown together with the emission data. In the event that the technique(s) implemented does not abate the pollutant displayed in a specific graph, or when no technique is implemented, the label 'NT' is shown together with the emission data.

Due to the large volume of data reported, some of the graphs are split to improve their readability.

2.3.6.8.1 Chemical oxygen demand (COD)

COD is commonly used to indirectly measure the amount of organic compounds in water by measuring the mass of oxygen needed for their total oxidation to carbon dioxide. The most widespread COD monitoring methods use dichromate as an oxidising agent and mercury salts to suppress the influence of inorganic chloride. COD has to be considered in relation to TSS since the TSS removal efficiency affects the performance achieved with respect to COD. For economic and environmental reasons, COD is being replaced to some extent by TOC.

Performance of installations participating in the data collection

Often, 24-hour composite samples are taken on a daily, weekly or monthly basis.

Figure 2.21, Figure 2.22, Figure 2.23 and Figure 2.24 show COD emissions to water (concentrations for direct discharges, daily average) from FDM installations participating in the data collection. The related FDM sectors and final abatement techniques are also depicted.

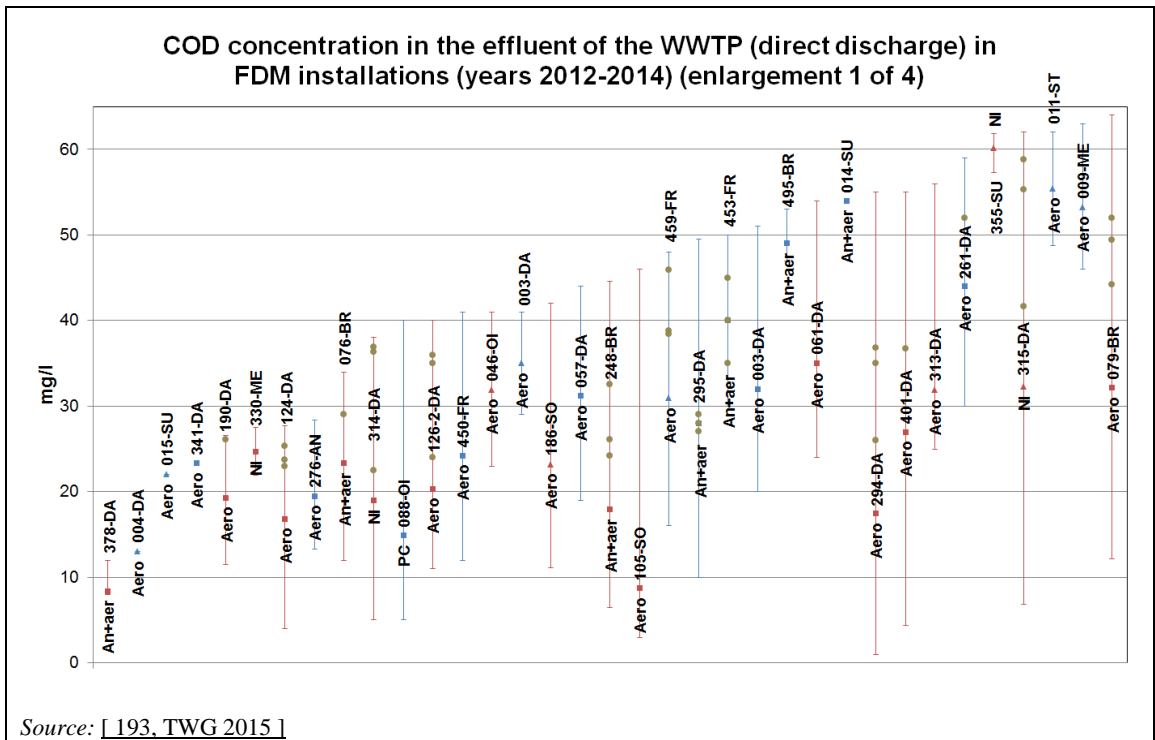

Figure 2.21: COD concentration in the effluent of the WWTP (direct discharge) in FDM installations (1 of 4)

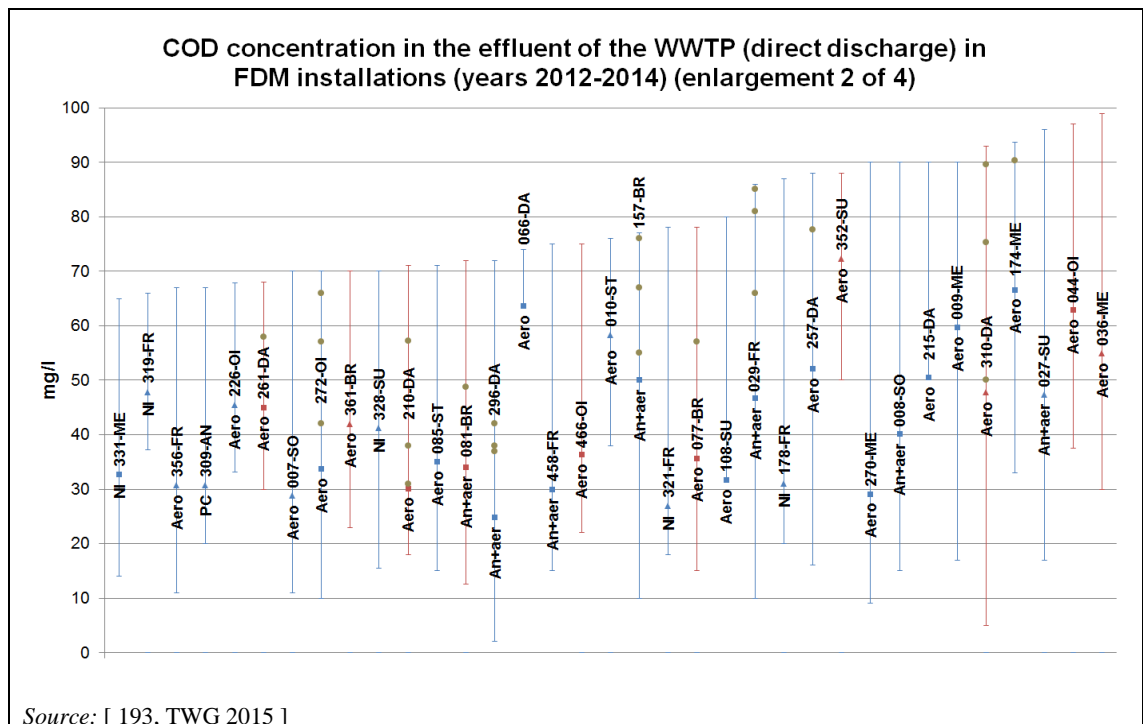

Figure 2.22: COD concentration in the effluent of the WWTP (direct discharge) in FDM installations (2 of 4)

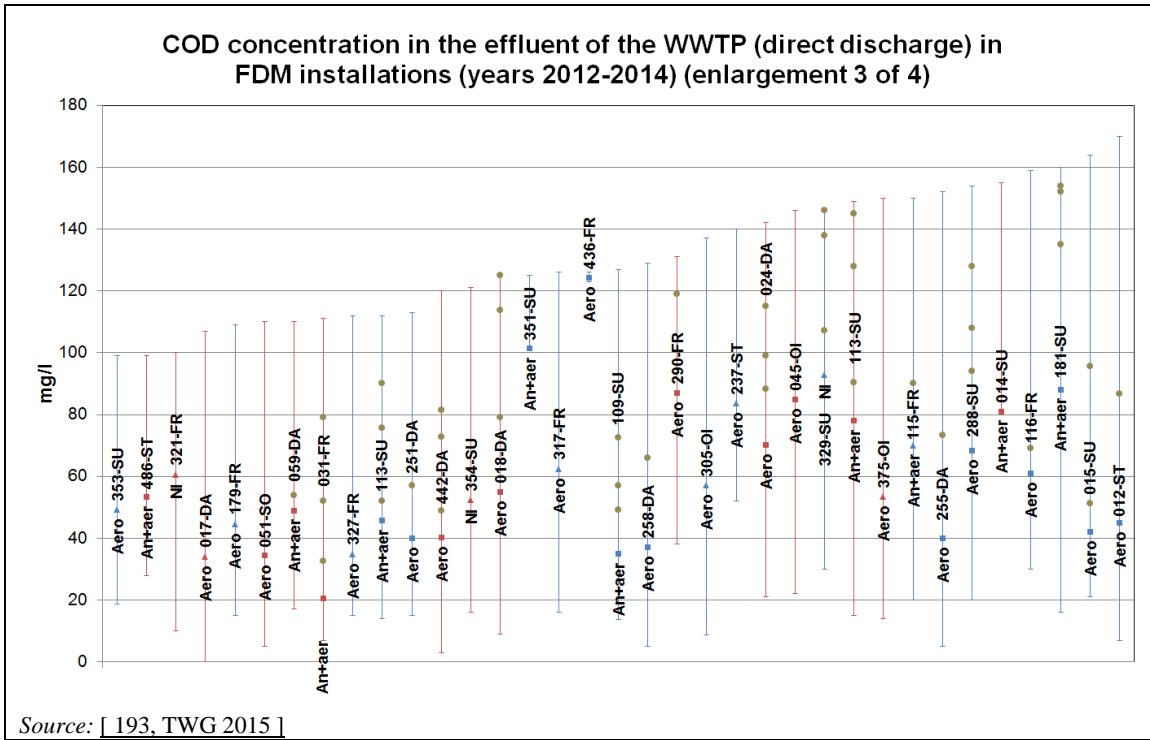

Figure 2.23: COD concentration in the effluent of the WWTP (direct discharge) in FDM installations (3 of 4)

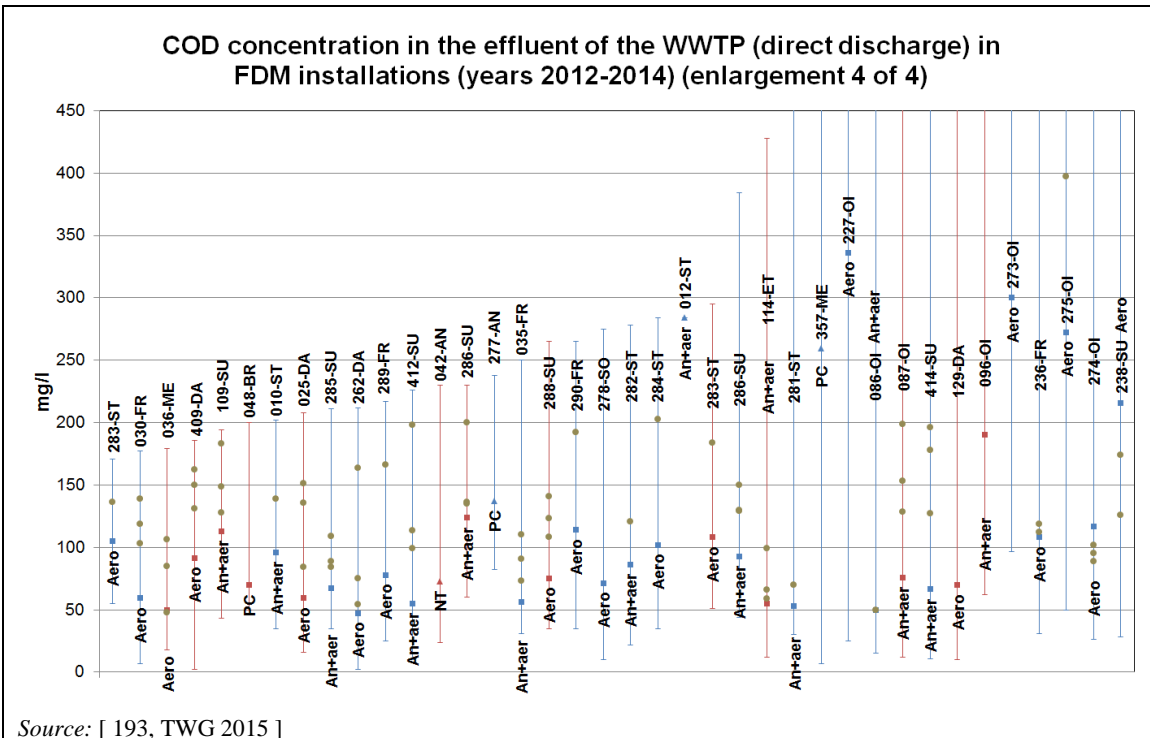

Figure 2.24: COD concentration in the effluent of the WWTP (direct discharge) in FDM installations (4 of 4)

Figure 2.25 shows COD emissions to water as specific loads for direct discharges from FDM installations.

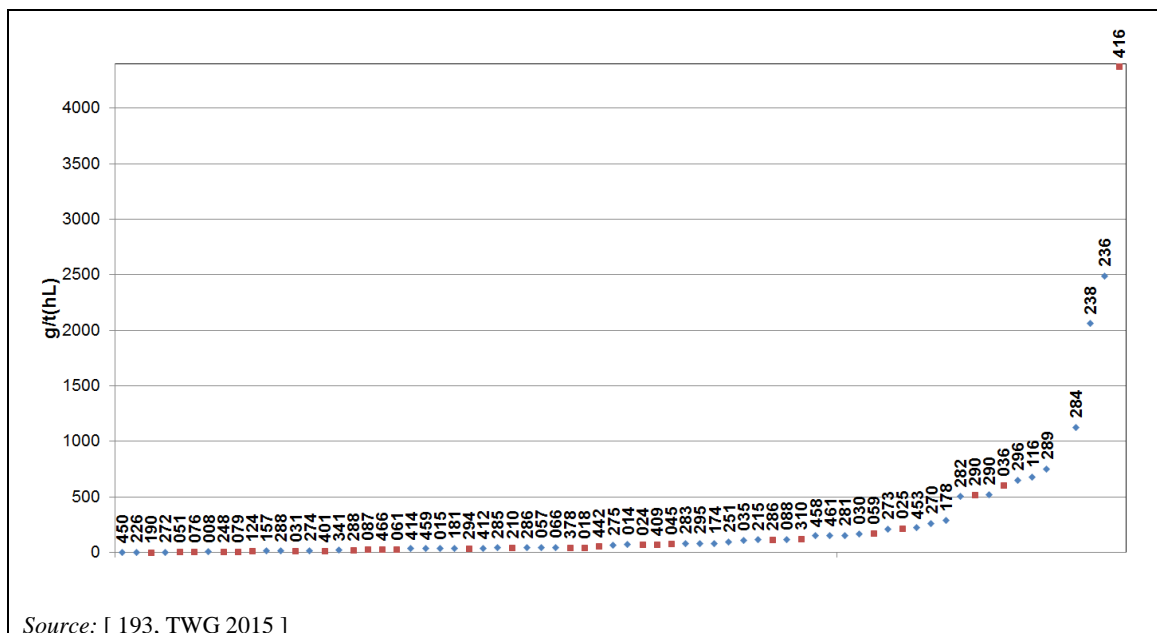

Figure 2.25: COD specific load in the effluent of the WWTP (direct discharge) in FDM installations

Techniques reported to reduce COD emission levels

There are many techniques for the reduction of COD emission levels, belonging to primary and/or secondary treatment (see Section 2.3.6), implemented in all installations.

There is no clear performance trend associated with the use of certain technologies or combinations thereof. The final effluent concentration very much depends on the way the WWTP is designed, maintained and operated. Regardless of the type of treatment system selected, one of the keys to effective biological treatment is to develop and maintain an acclimated, healthy biomass, sufficient in quantity to handle maximum flows and the organic loads to be treated.

2.3.6.8.2 Total organic carbon (TOC)

Total organic carbon (TOC) analysis is used to directly measure the amount of organic compounds in water. The most widespread methods use a combustion chamber to completely oxidise the organic substances to carbon dioxide which is then measured by spectrometry. Inorganic carbon is not included in TOC. Identifying changes in the normal/expected TOC concentrations can be a good indicator of potential threats to a waste water treatment system. Various online TOC analysers exist. There is a tendency to replace COD with TOC for economic and ecological reasons.

Performance of installations participating in the data collection

Often, 24-hour composite or time-proportional samples are taken on a daily or monthly basis.

Figure 2.26 shows TOC emissions to water (concentrations for direct discharges, daily averages) from FDM installations participating in the data collection. The related FDM sectors and final abatement techniques are also depicted.

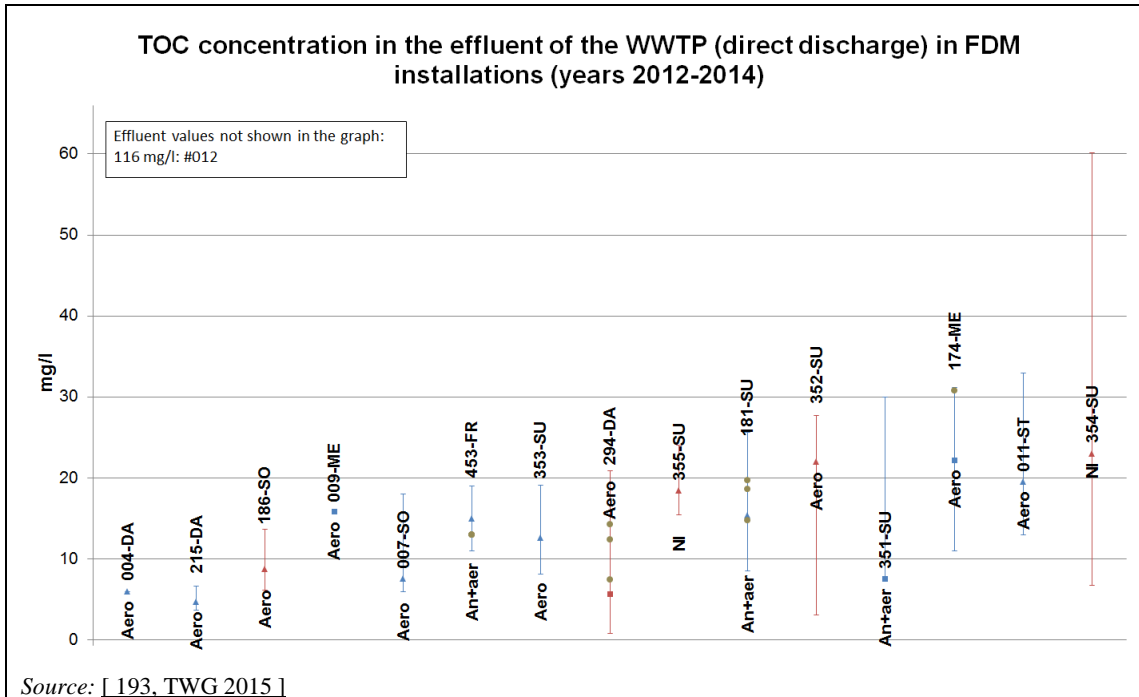

Figure 2.26: TOC concentration in the effluent of the WWTP (direct discharge) in FDM installations

Figure 2.27 shows TOC emissions to water as specific loads for direct discharges from FDM installations.

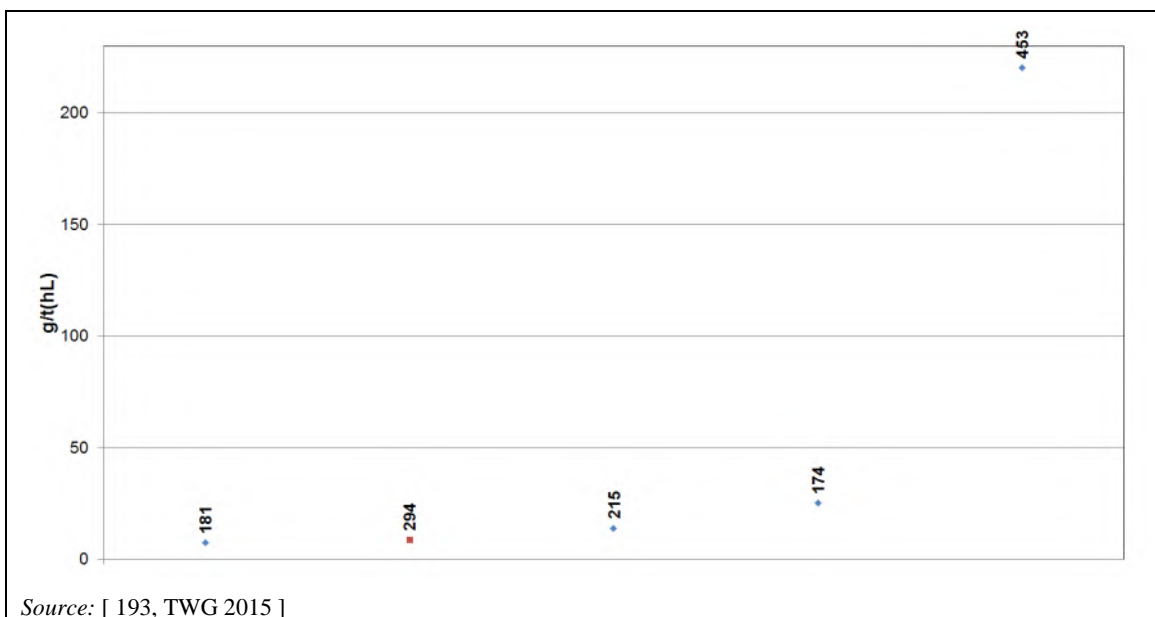

Figure 2.27: TOC specific load in the effluent of the WWTP (direct discharge) in FDM installations

Techniques reported to reduce TOC emission levels

The techniques are the same as those indicated in the COD section (see Section 2.3.6.8.1).

2.3.6.8.3 Biochemical oxygen demand in five days (BOD₅)

BOD₅ measures the amount of dissolved oxygen required or consumed in five days at a constant temperature for the microbiological decomposition (oxidation) of organic material in water. The concentration in the effluent is generally a more pertinent parameter than the abatement efficiency.

The parameters COD and TOC can be determined more quickly than BOD₅. Furthermore, the use of BOD₅ as a parameter to describe the efficiency of biological treatment has some disadvantages such as:

- the monitoring method used is not very accurate considering reproducibility and methodology dependence (dilution method versus respirometer for example);
- the analytical result depends on the local conditions of the laboratory, such as the inoculum used for the test;
- the BOD₅ measurement does not allow for any prediction of the performance within the WWTP; it only provides an indication as to whether the waste water is easily degradable to a certain rate.

Performance of installations participating in the data collection

Often, 24-hour composite samples are taken on a weekly or monthly basis.

Figure 2.28, Figure 2.29 and Figure 2.30 show BOD₅ emissions to water (concentrations for direct discharges, daily averages) from FDM installations participating in the data collection. The related FDM sectors and final abatement techniques are also depicted.

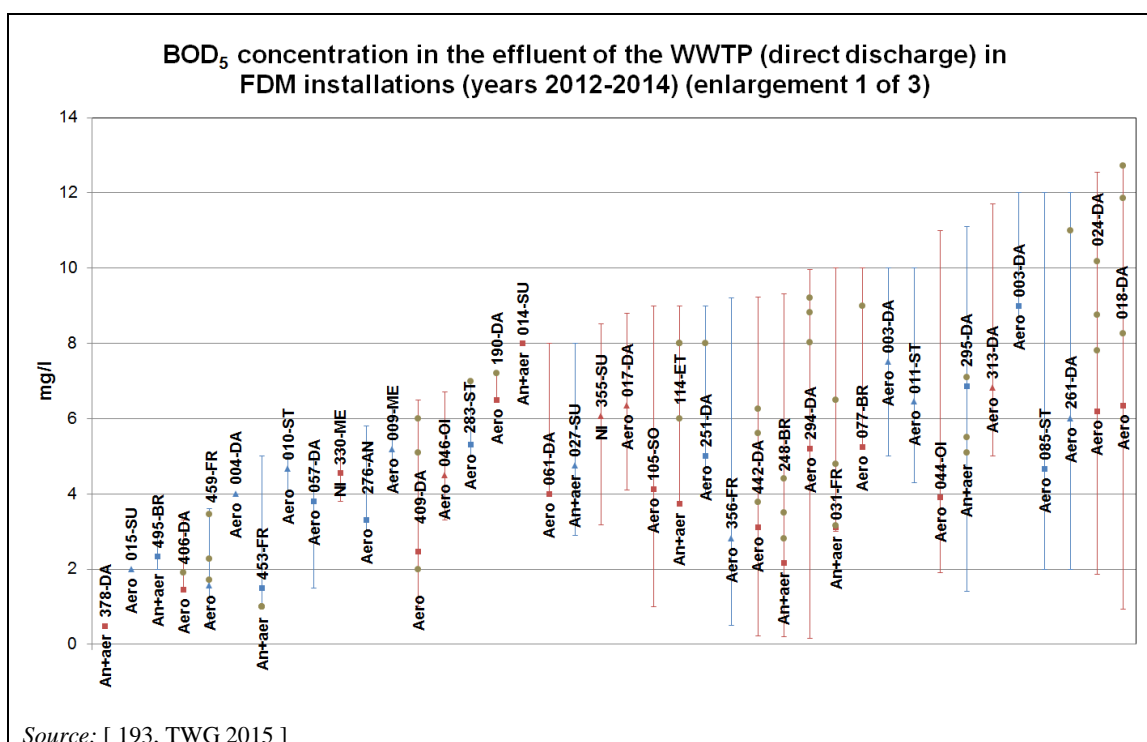

Figure 2.28: BOD₅ concentration in the effluent of the WWTP (direct discharge) in FDM installations (1 of 3)

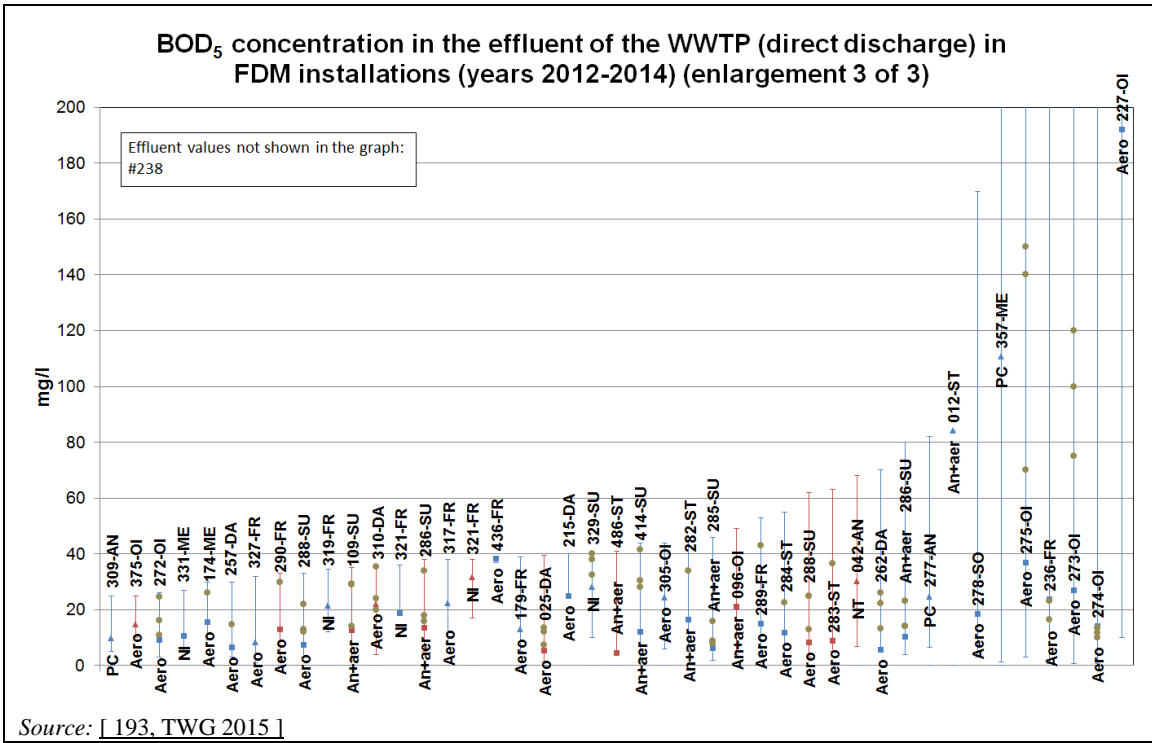

Figure 2.29: BOD₅ concentration in the effluent of the WWTP (direct discharge) in FDM installations (2 of 3)

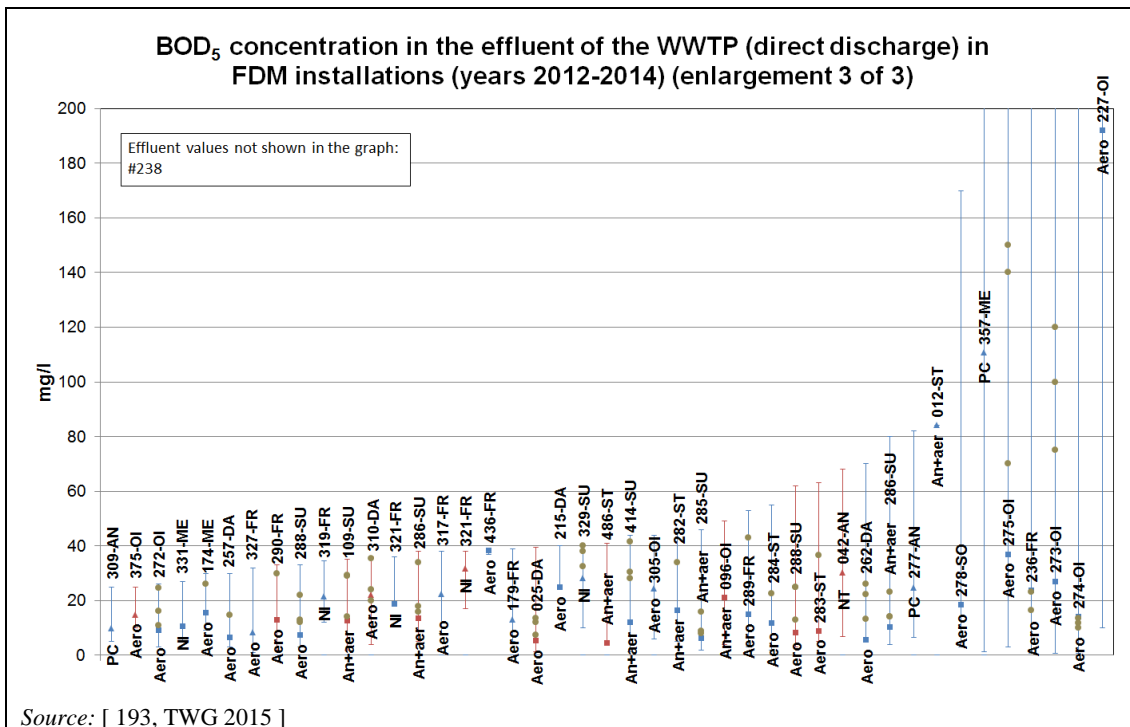

Figure 2.30: BOD₅ concentration in the effluent of the WWTP (direct discharge) in FDM installations (3 of 3)

Figure 2.31 shows BOD₅ emissions to water as specific loads for direct discharges from FDM installations.

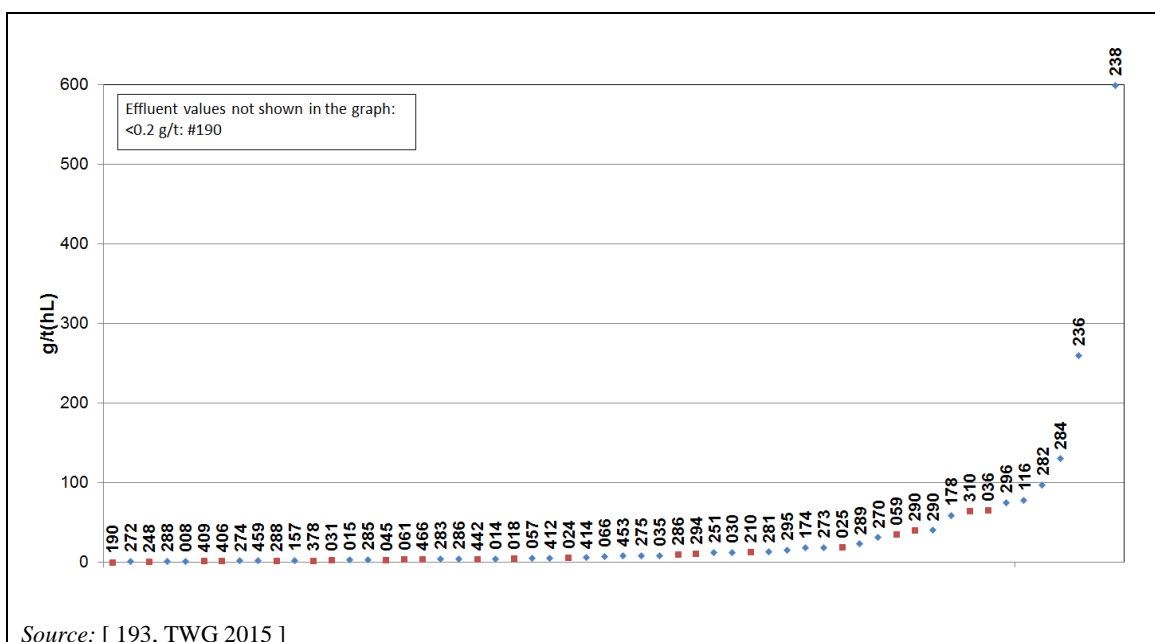

Figure 2.31: BOD₅ specific load in the effluent of the WWTP (direct discharge) in FDM installations

Techniques reported to reduce BOD₅ emission levels

The techniques used to remove COD (see Section 2.3.6.8.1) may remove (part of the) BOD₅ too. On the other hand, pretreatment of COD may in certain cases raise the BOD₅ (conversion of non-degradable to biodegradable matter, e.g. by partial oxidation). The only technique which is *a priori* dedicated to removing BOD₅ is biological treatment.

2.3.6.8.4 Total suspended solids (TSS)

There are some reasons to link the analysis of TSS with other parameters. If BOD/COD/TOC removal functions poorly, TSS emissions may be affected. Conversely, high TSS values can correlate with or cause high concentrations of other parameters, namely BOD, TOC or COD, total phosphorus and total nitrogen.

It is possible to have higher TSS values in the effluent than in the influent, for example due to the growth of biomass during biological treatment or due to the precipitation of compounds during physico-chemical treatment. In most cases, it therefore does not make sense to calculate abatement efficiencies for the WWTP.

Performance of installations participating in the data collection

Often, 24-hour composite samples are taken on a daily or monthly basis.

Figure 2.32, Figure 2.33 and Figure 2.34 show TSS emissions to water (concentrations for direct discharges, daily averages) from FDM installations participating in the data collection. The related FDM sectors and final abatement techniques are also depicted.

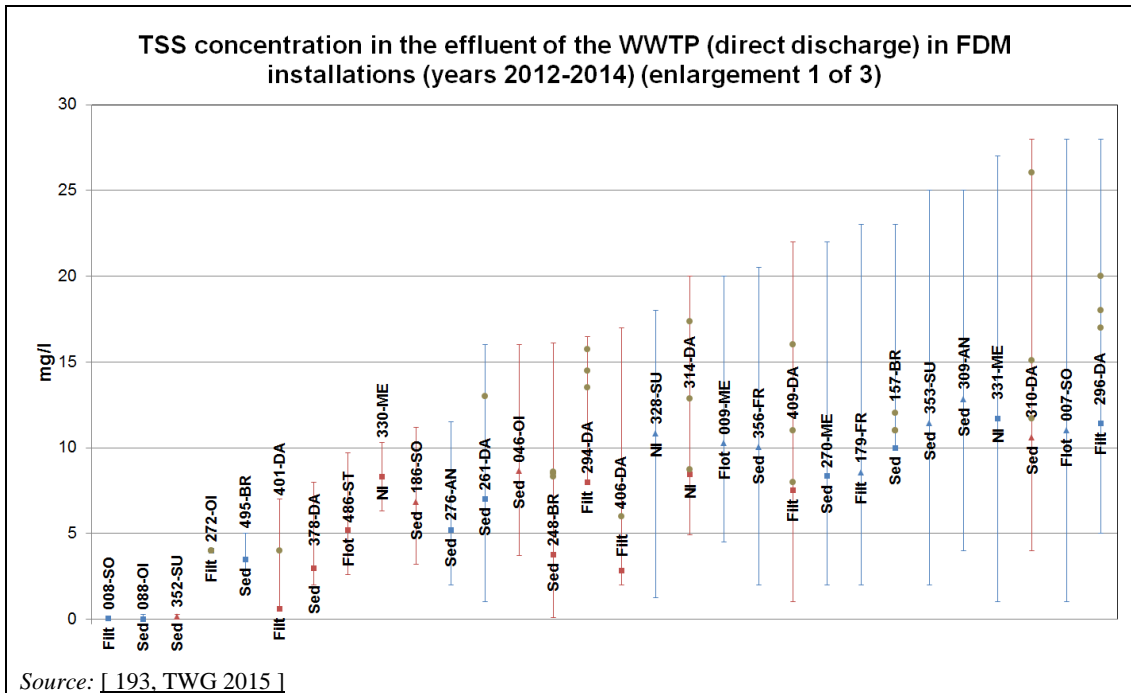

Figure 2.32: TSS concentration in the effluent of the WWTP (direct discharge) in FDM installations (1 of 3)

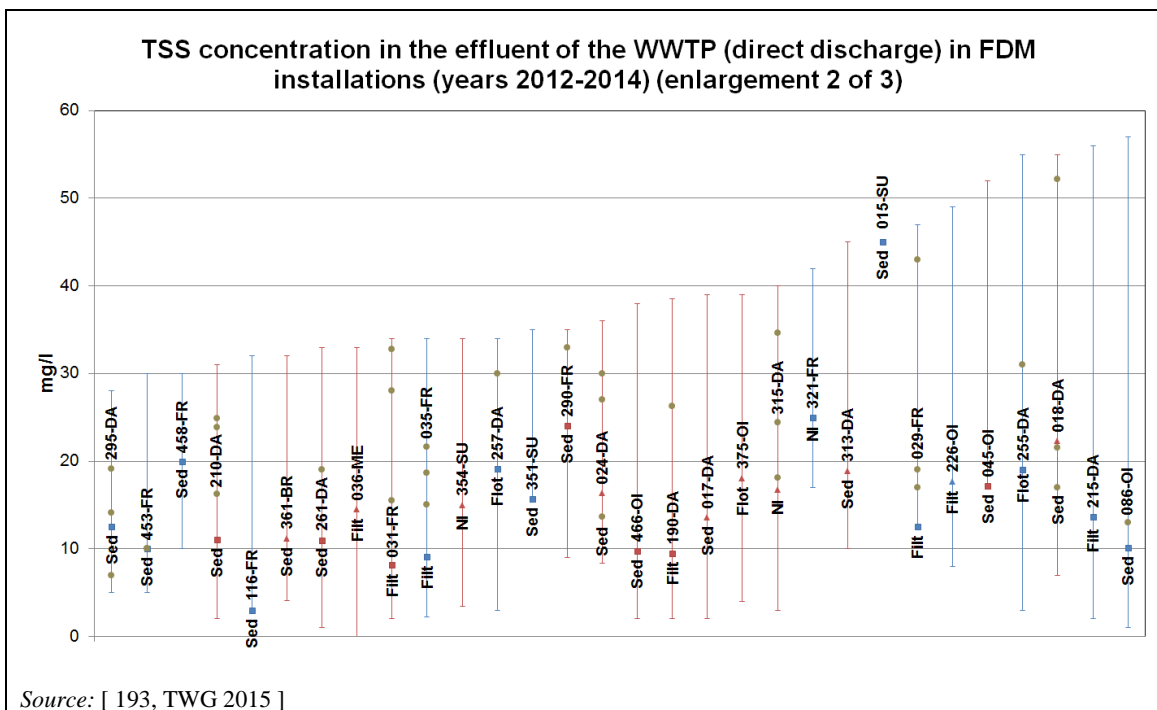

Figure 2.33: TSS concentration in the effluent of the WWTP (direct discharge) in FDM installations (2 of 3)

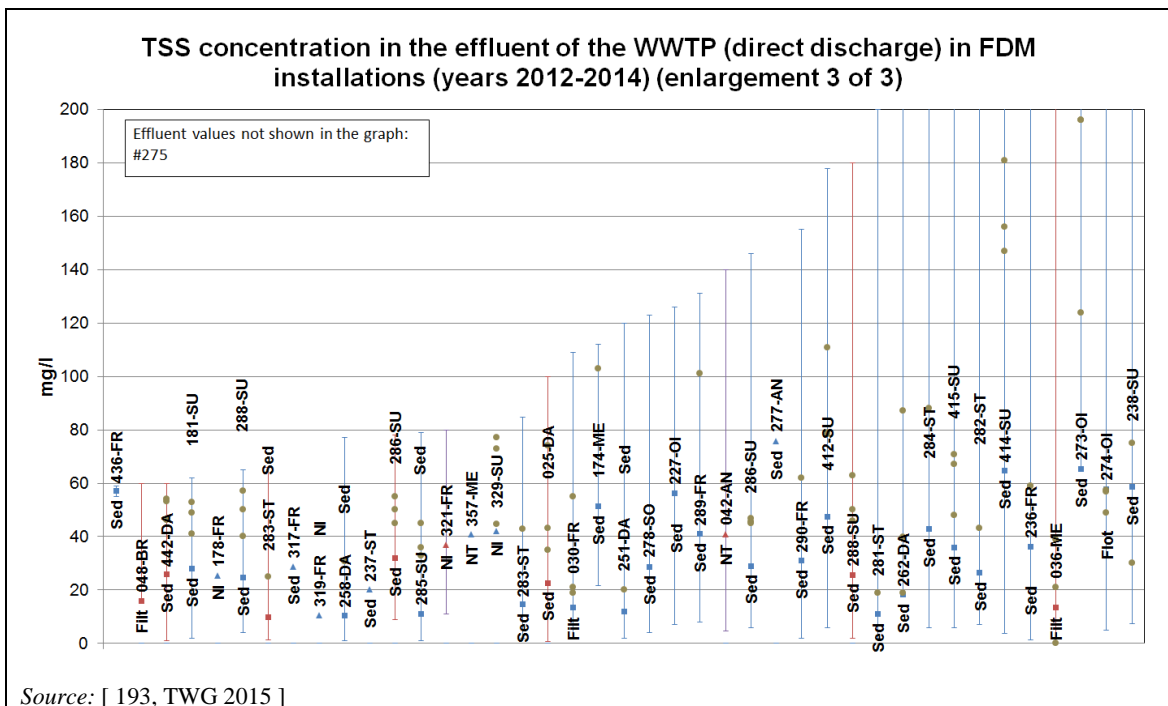

Figure 2.34: TSS concentration in the effluent of the WWTP (direct discharge) in FDM installations (3 of 3)

Figure 2.35 shows TSS emissions to water as specific loads for direct discharges from FDM installations.

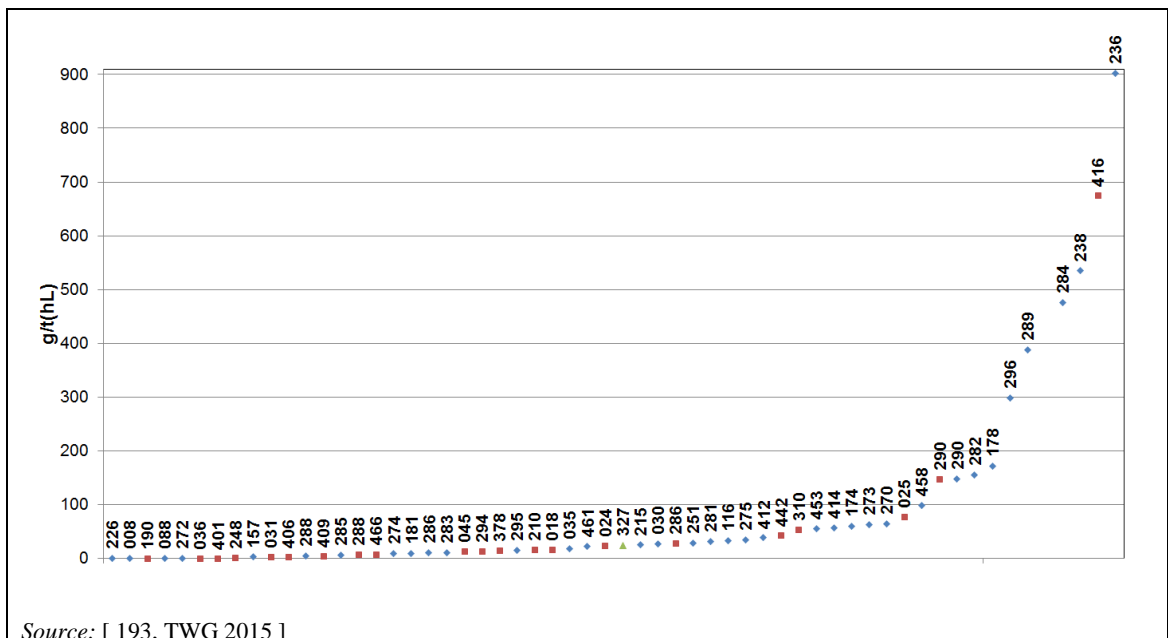

Figure 2.35: TSS specific load in the effluent of the WWTP (direct discharge) in FDM installations

Techniques reported to reduce TSS emission levels

As indicated in Table 2.4, sedimentation is most widely used, followed by screening and flotation. Filtration and flotation are often preceded by a sedimentation step. Installations using membrane filtration as the main solids removal step (often as part of a membrane bioreactor) show lower TSS values in the effluent.

2.3.6.8.5 Total nitrogen (TN)

The parameter total nitrogen (TN) includes free ammonia and ammonium (NH₄-N), nitrites (NO₂-N), nitrates (NO₃-N) and organic nitrogen compounds. Dissolved elementary nitrogen (N₂) is not included. TN is frequently measured by combustion with subsequent analysis of nitrogen oxides via chemiluminescence (i.e. total nitrogen bound = TN_b, e.g. according to EN 12260), or by oxidation with peroxodisulphate with subsequent wet-chemical analysis of nitrate (Koroleff method, e.g. according to EN ISO 11905-1). TN can also be determined by summing up the individual concentrations of total Kjeldahl nitrogen, NO₂-N and NO₃-N.

Performance of installations participating in the data collection

Often, 24-hour composite samples are taken on a daily or monthly basis.

Figure 2.36 (lower values) and Figure 2.37 (higher values) show TN emissions to water (concentrations for direct discharges, daily averages) from FDM installations participating in the data collection. The related FDM sectors and final abatement techniques are also depicted.

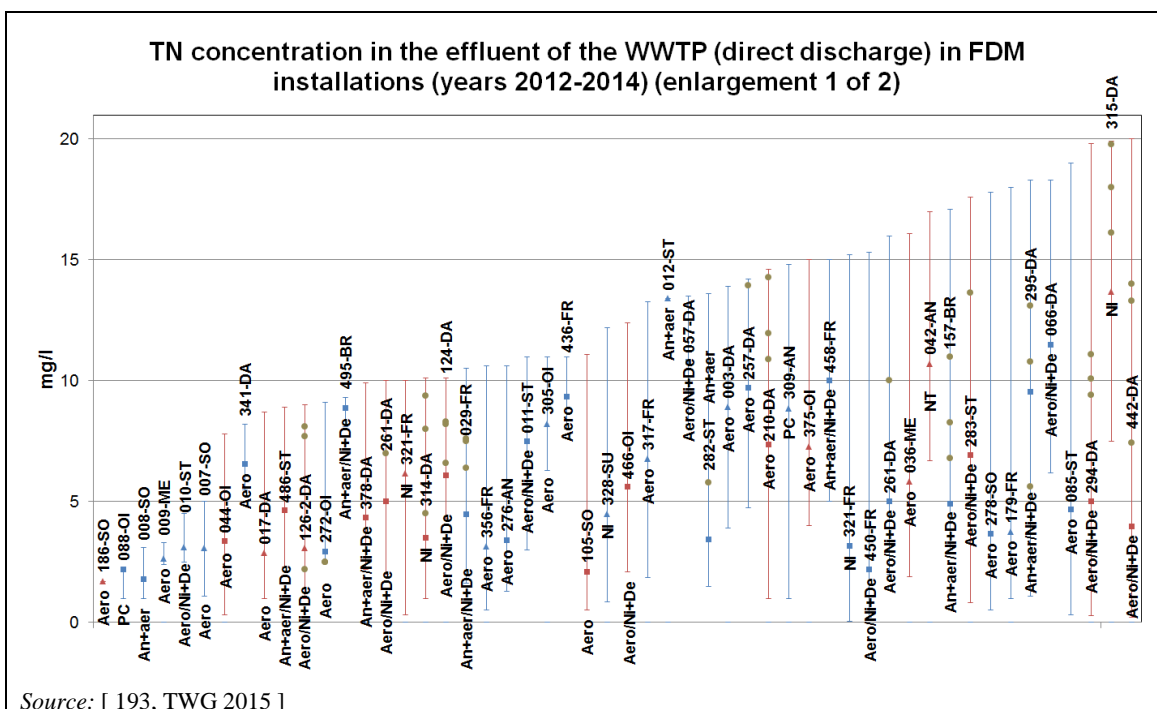

Source: [193, TWG 2015]

Figure 2.36: TN concentration in the effluent of the WWTP (direct discharge) in FDM installations (1 of 2)

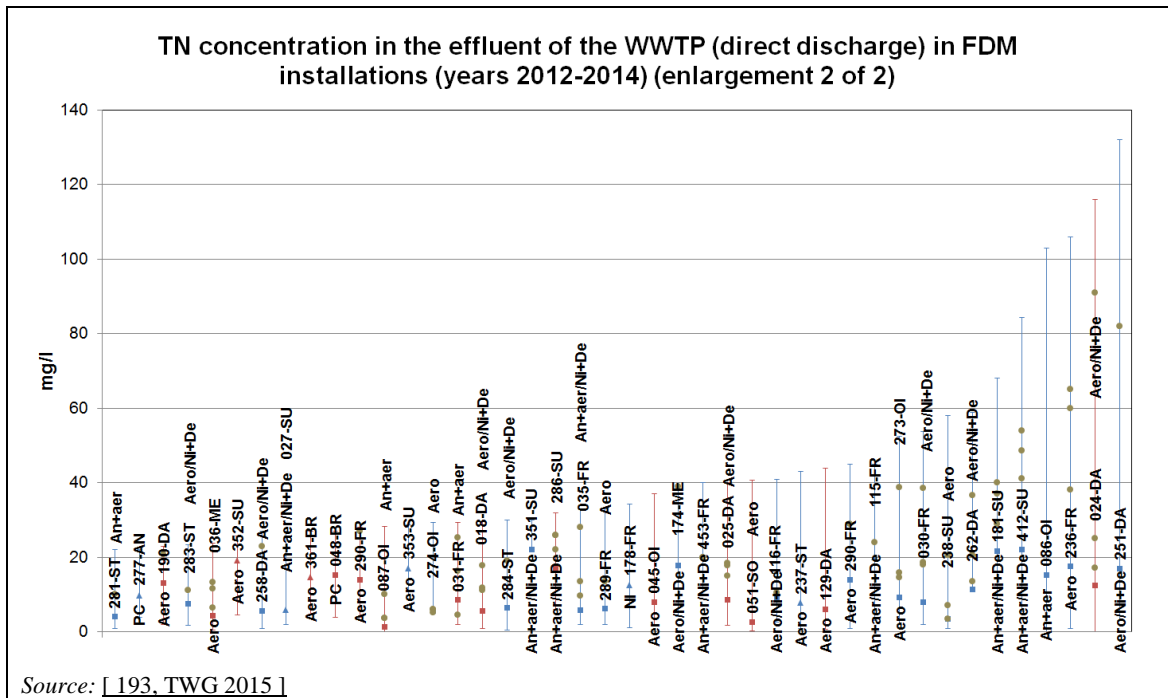

Figure 2.37: TN concentration in the effluent of the WWTP (direct discharge) in FDM installations (2 of 2)

Figure 2.38 shows TN emissions to water as specific loads for direct discharges from FDM installations.

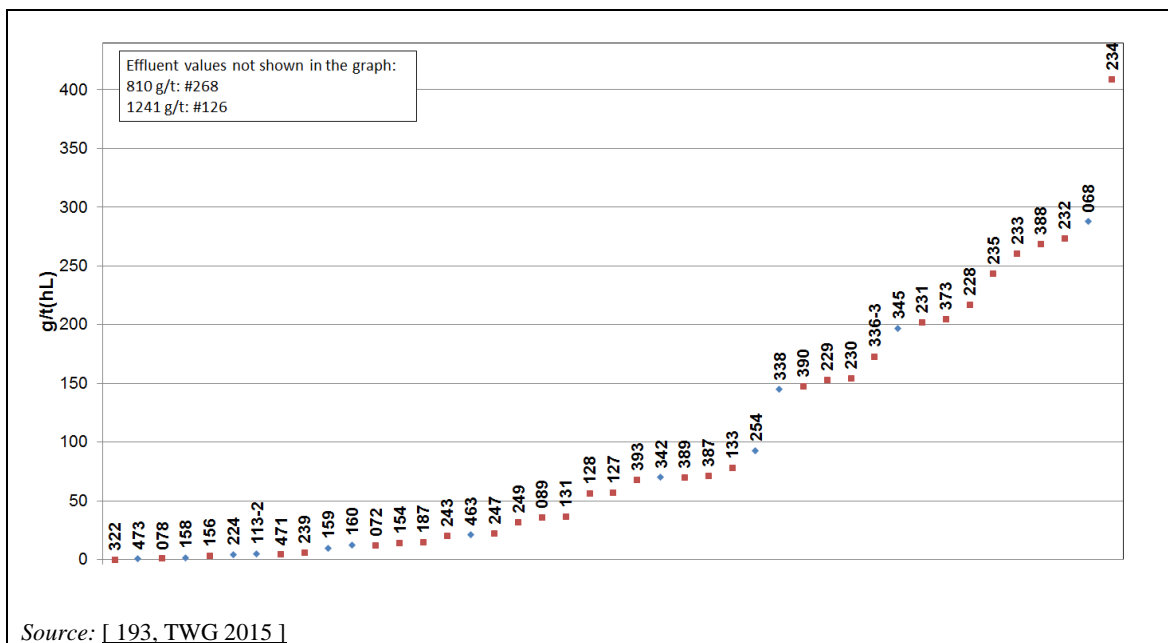

Figure 2.38: TN specific load in the effluent of the WWTP (direct discharge) in FDM installations

Techniques reported to reduce TN emission levels

As indicated in Table 2.4, biological nitrification and denitrification (as part of the overall biological waste water treatment) are widely implemented for abating TN emissions to water.

2.3.6.8.6 Total phosphorous (TP)

Phosphorus is present in waste water in inorganic and organic forms. The inorganic forms are orthophosphates (i.e. $\text{HPO}_4^{2-}/\text{H}_2\text{PO}_4^-$) and polyphosphates. Organically bound phosphorus is usually of minor importance. Polyphosphates can be used as a means of controlling corrosion. Phosphorus discharge has to be controlled in the same way as nitrogen discharge in order to avoid eutrophication of a surface water body. It was reported that, to avoid algal blooms under summer conditions, the critical level of inorganic phosphorus is near 0.005 mg/l.

Performance of installations participating in the data collection

Often, 24-hour composite samples are taken on a daily or monthly basis.

Figure 2.39, Figure 2.40 and Figure 2.41 show TP emissions to water (concentrations for direct discharges, daily averages) from FDM installations participating in the data collection. The related FDM sectors and final abatement techniques are also depicted.

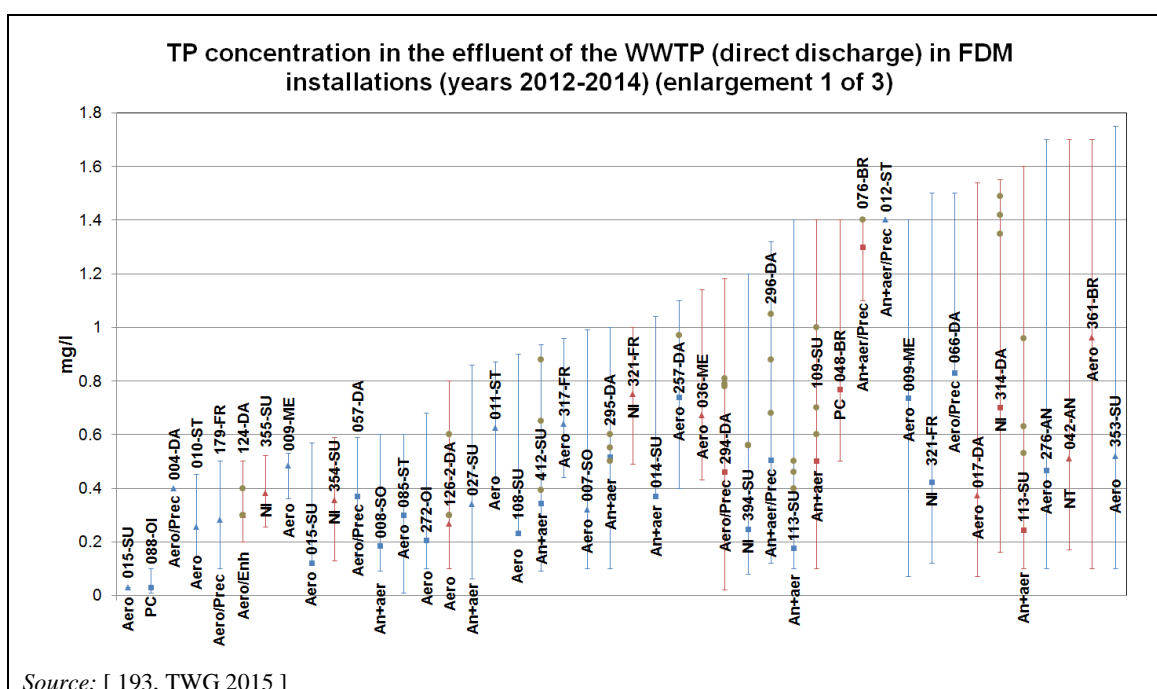

Figure 2.39: TP concentration in the effluent of the WWTP (direct discharge) in FDM installations (1 of 3)

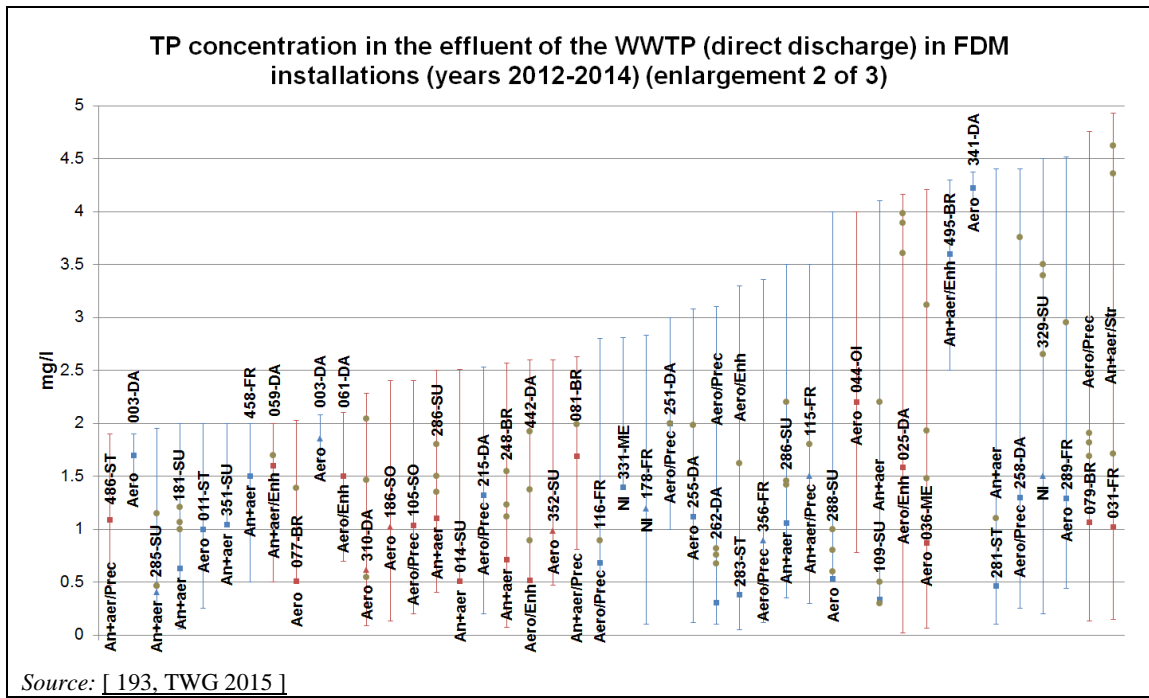

Figure 2.40: TP concentration in the effluent of the WWTP (direct discharge) in FDM installations (2 of 3)

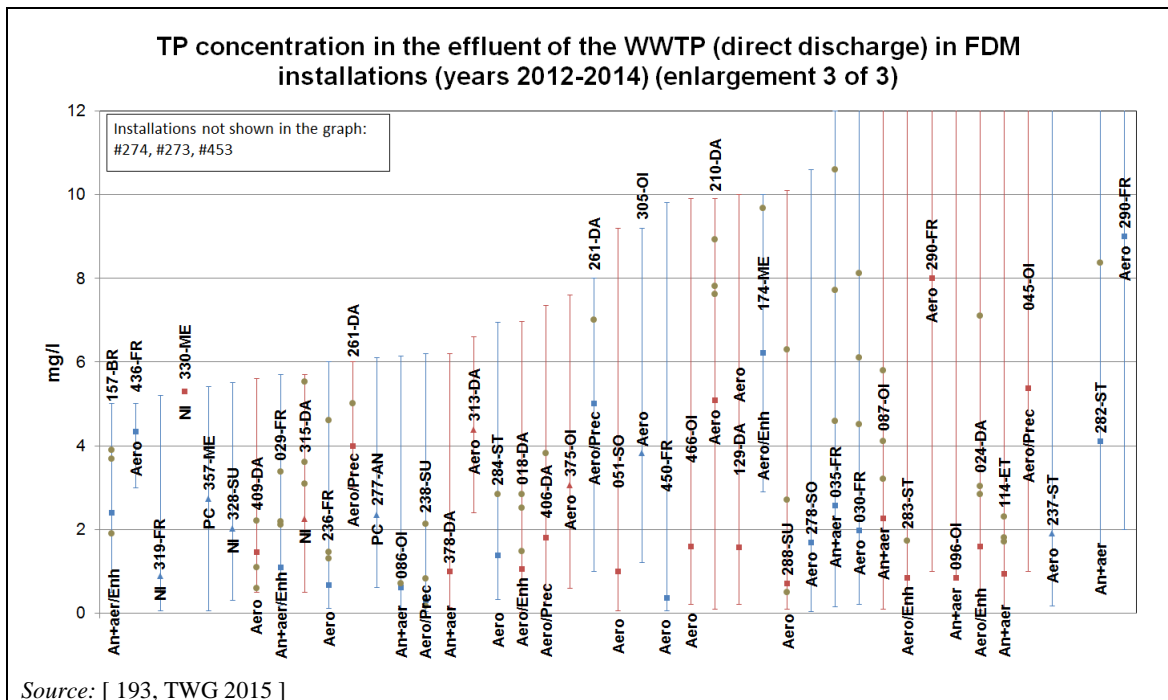

Figure 2.41: TP concentration in the effluent of the WWTP (direct discharge) in FDM installations (3 of 3)

Figure 2.42 shows TP emissions to water as specific loads for direct discharges from FDM installations.

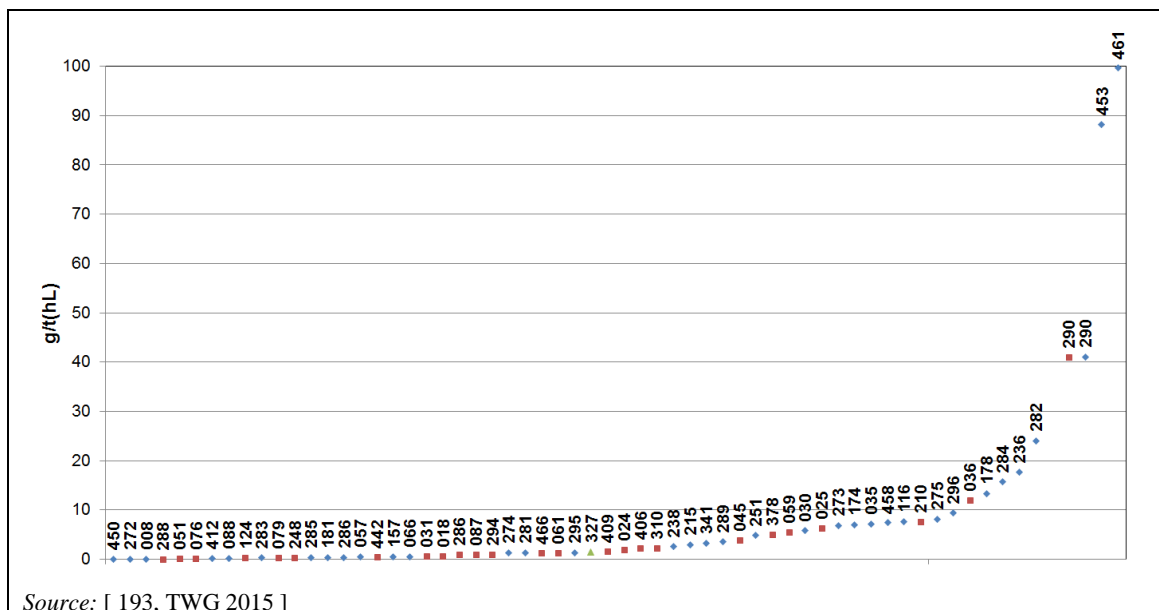

Figure 2.42: TP specific load in the effluent of the WWTP (direct discharge) in FDM installations

Techniques reported to reduce TP emission levels

As indicated in Table 2.4, phosphorus removal by biological treatment and chemical precipitation is commonly applied.

2.3.7 Techniques to reduce emissions to air

2.3.7.1 Techniques applicable for a number of pollutants

2.3.7.1.1 Collection of emissions to air at source and local exhaust ventilation

Description

Enclosure of sources of emissions to air and the use of local exhaust ventilation, rather than treating the whole room.

Technical description

Enclosure of sources of emissions to air and the use of local exhaust ventilation use considerably less energy than treating the whole room volume. To be effective, the dimensions of suction capacity need to be adequate and features such as guide plates and hoppers with swing flaps and lids can contribute to the minimisation of dust and gas emissions.

The identified emissions requiring treatment are ducted at source and possibly combined before being transported to an abatement technique. The objective of the equipment is that it prevents, where possible, and controls to a minimum the escape of all emissions to air. The following are examples of areas of concern:

- vehicle loading/unloading points;
- access points to the process plant;
- open conveyors;
- storage vessels;
- transfer processes;
- filling processes;
- discharge processes.

It is important to distinguish between general ventilation of the installation and local exhaust ventilation. General ventilation involves the movement of much larger volumes of air, so uses more energy and is more expensive. Local exhaust ventilation can provide protection from hazards to health arising from some cooking fumes, such as those involving direct application of heat to the food. Unless such ventilation is designed to be kept clean and free from fat residues, it can lose efficiency and cause fire risks. If incoming replacement air is too hot or too cold, there is a risk that staff will switch it off. Where incoming air is drawn in naturally, some means of control over pest entry is usually required. The ventilated air can be extracted to an abatement plant and, in some cases, it may be recirculated, taking into consideration the hygiene requirements. In some applications, it is possible to collect airborne materials for reuse.

Achieved environmental benefits

Reduced emissions to air and potential reuse of airborne materials.

Environmental performance and operational data

The majority of abatement techniques are designed based on the volumetric airflow to be treated. This requires effective containment of the separate emissions whilst still maintaining an adequate volumetric flow rate of air to ensure no ingress of emissions to air into the working environment. Examples where air is recirculated include:

- recirculation of coffee roasting gases from continuous or discontinuous roasting;
- dust-laden feed air can be recirculated to pneumatic conveyors, thereby also collecting the dust for reuse;
- smoke from smoking chambers can be partially or wholly recirculated.

Cross-media effects

Energy consumption.

Technical considerations relevant to applicability

Applicable to all FDM installations with emissions to air, e.g. during loading and unloading vehicles; at hoppers, transfer points, chutes, loading pipes.

Economics

No information provided.

Driving force for implementation

- Occupational health.
- There can be considerable cost savings made in the capital cost of the abatement plant by minimising the volumetric flow rate requiring treatment.

Example plants

This technique is widely applied in the FDM sector.

Reference literature

[16, Willey et al. 2001], [35, Germany 2002], [139, Health and Safety Executive 2000]

2.3.7.1.2 Exhaust gas recirculation

Description

Recirculation of (part of) the waste gas to a combustion chamber to replace part of the fresh combustion air.

Technical description

It may be possible to direct the waste gases to an existing on-site boiler. This has the advantage of using existing equipment and avoiding the expense of investing in an additional treatment option. The principle of operation is essentially the same as for thermal oxidation in a purpose-built plant.

The exhaust stream is ducted to the combustion airflow fan of the boiler or boiler house, then to the boiler. It provides oxygen to the combustion process and the organic compounds are destroyed.

The overall feasibility of using an existing boiler largely depends upon the volume of waste gas to be treated in relation to the boiler combustion air requirements under extreme loads. If the volume of waste gas is significantly less than the combustion air requirements then it is unlikely to present a problem. The total volume of waste gas could simply be ducted through the combustion fan. However, the vast majority of operating conditions result in the boiler operating in a cyclic mode in response to a steam pressure signal.

Potential implications for the boiler operation need to be fully ascertained. The safety features associated with routing a waste gas discharge to a boiler are essentially included in the existing boiler operation. Flame arrestors or water seals may need to be added to prevent flame flashback between the boiler and the gas stream to be treated.

For more information consult the LCP BREF [[145, COM 2017](#)].

Achieved environmental benefits

Reduced dust, NO_x, CO, TVOC and odour emissions.

Environmental performance and operational data

This technique is highly efficient and, if correctly operated, as efficient at eliminating odours as other burning methods.

An important initial consideration is to check whether the boiler would be operating when waste gases are produced. This, for most operations, is likely to be the case. The control strategy for the boiler could change from being dependent upon the steam pressure to being dependent upon the combustion airflow rate. The combustion airflow rate would then be set to a minimum, i.e. equivalent to the volume of waste gas to be treated, which in turn would set a minimum fuel flow rate and firing rate. When the steam set point pressure is achieved, the boiler reverts to operation at the minimum combustion airflow rate and the unwanted heat is discharged through the boiler stack. A key part of the evaluation is to ascertain the percentage of time that the boiler operates with a combustion airflow rate lower than the waste gas flow rate, to calculate additional fuel costs.

Cross-media effects

Energy consumption is a cross-media effect. Fuel consumption may increase as it may be necessary to keep the boiler running when it would not otherwise have been required.

Technical considerations relevant to applicability

Airstreams containing significant quantities of dust generally require pretreatment prior to the post-combustion process.

Economics

The potential to use an existing boiler house has economic benefits, both in terms of capital costs and operating costs.

Driving force for implementation

Compliance with legal requirements.

Example plants

Installation #352 [[193, TWG 2015](#)].

Reference literature

[[16, Willey et al. 2001](#)], [[145, COM 2017](#)], [[193, TWG 2015](#)]

2.3.7.1.3 Combustion optimisation

For more information consult the LCP BREF [145, COM 2017].

Description

Measures taken to maximise the efficiency of energy conversion, e.g. in the furnace/boiler, while minimising emissions (in particular of CO). This is achieved by a combination of techniques including good design of the combustion equipment, optimisation of the temperature (e.g. efficient mixing of the fuel and combustion air) and the residence time in the combustion zone, and/or use of an advanced control system.

Technical description

The technique includes the good design of the furnace, combustion chambers, burners and associated devices and the regular planned maintenance of the combustion system according to suppliers' recommendations.

Achieved environmental benefits

Reduction of NO_x, N₂O, CO and other unburnt emissions to air in a balanced way.

Reference literature

[145, COM 2017]

2.3.7.2 Techniques to reduce dust emissions

2.3.7.2.1 Separator

Description

The waste gas stream is passed into a chamber where the dust, aerosols and/or droplets are separated from the gas under the influence of gravity/mass inertia.

Technical description

The waste gas stream is passed into a chamber where the dust, aerosols and/or droplets are separated from the gas under the influence of gravity/mass inertia. The effect is increased by reducing the gas velocity by design means, e.g. baffles, lamellae or metal gauze.

Separators could resemble a horizontally mounted fan body, but the air is fed into a circular body where the dust moves to the outside wall of the separators under centrifugal force. The dust is collected from the outside wall by a collection vessel and diverted down into a rotary airlock seal and on to recovery. The air, now without the dust, is expelled vertically through a stack to atmosphere.

The design should ensure a good uniform speed distribution inside the vessel. Preferential flows have an adverse effect on efficiency. The use of internal obstructions in the inertia separator enables operation at higher speeds, which represents a reduction in volume of the separator compared with the settling chamber. The drawback is the increasing pressure drop.

Achieved environmental benefits

Reduction of dust emissions to air. Potential reuse of airborne materials.

Environmental performance and operational data

Separators are characterised by a simple and robust design, small space requirements and high operating reliability. The technique requires minimum airflow to maintain performance.

Deflection or inertia separators enable effective dust removal. Due to their inertia, larger particles are unable to follow the repeatedly deflected gas stream and are separated. With the appropriate design, it is possible to achieve separation rates of 50 % for particles in excess of 100 µm.

Cross-media effects

Energy consumption.

Technical considerations relevant to applicability

Separators are suitable for use where:

- there are high emission levels of dust in the untreated gas;
- there is no great requirement for the removal of fine particles;
- there is a need for preliminary separation and/or protection and relief of downstream systems;
- pressures are high, e.g. high-pressure dedusting;
- temperatures are high, e.g. high-temperature dedusting.

Economics

Low-cost technique.

Driving force for implementation

No information provided.

Example plants

See Table 2.8.

Reference literature

[35, Germany 2002]

2.3.7.2.2 Bag filter

Description

Bag filters, often referred to as fabric filters, are constructed from porous woven or felted fabric through which gases are passed to remove particles. The use of a bag filter requires the selection of a fabric suitable for the characteristics of the waste gas and the maximum operating temperature.

Technical description

Bag filter or fabric filter systems work by passing air containing particulates through a filter medium which traps the particles as the air is forced through the filter media. The process takes place inside filter units which are placed in the flow of the air to be filtered. To maintain the efficiency of the filter media, they are cleaned at regular intervals either by being vigorously shaken or a reverse jet of air blown through them to release any material held on the filter - this material is then collected and reused in the production process. It is necessary to change the filter media regularly to ensure that they remain efficient and that there are no microbiological risks to the installation resulting from accumulation of material on the filter media.

Most bag filters use long, cylindrical bags (or tubes) made of woven or felted fabric as a filter medium, suitable for the characteristics of the hot gas and the maximum operating temperature.

Bag filters are made up of filter material up to about 30 mm thick and measure up to 0.5 m high and 1.5 m long. The filter bags are fitted with their open end towards the clean gas duct. In tubular filters, the filter medium consists of tubes up to 5 metres long with a diameter of between 12 cm and 20 cm. The untreated gas stream always flows from outside to inside, usually in the upper region of the filter bag.

Table 2.63 shows a comparison between different bag filter systems and Figure 2.43 shows an industrial bag filter.

Table 2.63: Comparison between different bag filter systems

Parameter	Pulse jet filter	Membrane fibreglass filter	Fibreglass filter
Air to cloth ratio	22–25 m/s	19–25 m/s	8–10 m/s
Temperature limits	200 °C	280 °C	280 °C
Bag type	Polyester	Membrane/fibreglass	Fibreglass
Bag size	0.126 x 6.0 m	0.292 x 10 m	0.292 x 10 m
Cloth area per bag	2.0 m ²	9.0 m ²	9.0 m ²
Cage	Yes	No	No
Pressure drop	2.0 kPa	2.0 kPa	2.5 kPa
Bag life	Up to 30 months	6–10 years	6–10 years

Source: [35, Germany 2002]

As a general rule, the average distance between fibres is considerably larger than the particles to be collected. The separation rates due to the screen effect are also supplemented by mass forces, obstructive effects and electrostatic forces.



Figure 2.43: Picture of an industrial bag filter

In the tubular bag filter systems, the equipment contains a round filter comprising a bank of vertical tubes mounted in a cylinder, similar in appearance to a cyclone and which does not require significant space. The airstream is passed through the filter and the fines are deposited on the surface of the individual tubular filters. The tubular filters are cleaned by means of a fully automatic pulse-like reverse flushing system, using compressed air or other pressurised gases, with the aid of a multistage injector system. The tubes are cleaned individually, which ensures continuous cleaning of the tubular filters and dust removal.

The product cleaned off the tubular filters falls onto the outlet base, where it is conveyed by air flowing through a special perforation system, to the dust outlet. The gases cleaned in this way leave the filter as clean gas via a clean gas chamber.

Achieved environmental benefits

Reduced emissions of dust to air. Reduced waste production, e.g. due to the separation process being dry, it may, in principle, be possible to reuse separated particulate matter in the process, or as a by-product.

Environmental performance and operational data

Filter separators can achieve high separation rates, e.g. > 99 %, with even very fine particles being separated very efficiently. Bag filters may reduce dust emissions to < 5 mg/Nm³. The techniques to consider in the determination of BAT of the FDM sectorial chapters (see Chapters 3 to 15) contain installation-specific performance data related to the application of bag filters.

Filters use significantly less energy than cyclones and produce less noise. If filtering installations suitable for CIP are used for outgoing air, it is not necessary to use cyclones, allowing huge energy savings and noise reductions to be achieved. Reduced consumption of water and cleaning agents can be achieved by using CIP [35, Germany 2002].

Cross-media effects

Energy consumption. By-products are produced for which further treatment may be required. Bag filter material life is limited and creates another waste to dispose of.

Technical considerations relevant to applicability

Application is limited for sticky emissions to air. Bag filters may be less effective in applications with waste gas temperatures over 240 °C. Depending on the flow rate design parameters, they can reach significant volumes and require considerable space.

Economics

Although the investment costs of bag filters are relatively low, maintenance costs are high, as the filter material has to be changed every two to five years. Equipment associated with bag filters is more complex than cyclones and requires additional maintenance time. Precipitated material is generally easy to recycle and has some economic value.

The minimum expense associated with a filter change is approximately 10 % of the investment cost. This cost can be relevant for existing plants compared to the environmental benefit of lowering the emission levels. For example, for one Danish installation with an ELV of 25 mg/Nm³, a new ELV of 5 mg/Nm³ would result in an investment in new equipment of EUR 134 000–201 000, in addition to an annual yearly cost of EUR 8 000 to monitor and measure the compliance of the limit. Additionally, the very low limit would result in higher energy consumption [30, TWG 2018].

Driving force for implementation

- Legislation is the main driving force.
- For those installations where the separated ash can be reused, economics is also a driver.

Example plants

Bag filters are used in almost all the FDM sectors, see Table 2.8.

Reference literature

[30, TWG 2018], [35, Germany 2002], [145, COM 2017], [157, Copa-Cogeca 2016], [193, TWG 2015]

2.3.7.2.3 Cyclone

Description

Dust control system based on centrifugal force, whereby heavier particles are separated from the carrier gas.

Technical description

Cyclones use inertia to remove (generally large/coarse) particles from the gas stream by using centrifugal forces, usually within a conical chamber. They operate by creating a double vortex inside the cyclone body. The incoming gas is forced into circular motion down the cyclone near the inner surface of the cyclone tube. A high-speed rotating flow is established within a cylindrical or conical container called a cyclone. Larger (denser) particles in the rotating stream have too much inertia to follow the tight curve of the stream, and strike the outside wall, then fall to the bottom of the cyclone where they can be removed. At the bottom, the gas turns and spirals up through the centre of the tube and out of the top of the cyclone. Particles in the airstream are forced toward the cyclone walls by the centrifugal force of the spinning gas but are opposed by the fluid drag force of the gas travelling through and out of the cyclone. Large particles reach the cyclone wall and are collected in a bottom hopper, whereas small particles leave the cyclone with the exiting gas.

The efficiency of the cyclone mainly depends on the cyclone separator's geometric features (height) and the centrifugal force used (speed). The smaller the cyclone separator's radius, the greater the centrifugal acceleration and thus the better the separation. The particles are crushed against the walls of the cone, while the gas is expelled from the cyclone. This shape allows the improvement of the rotational speed, so, as the diameter decreases, theoretically even smaller particles of dust are separated from the air flow inside the cyclone.

It is important to observe the air flow for which the cyclone is dimensioned (flow and temperature). A product that is too dry is more volatile and does not stick to the walls of the cone properly. The humidity of the output air is observed as much as possible.

The cyclone is sensitive to the incoming air flow (humidity, dimension and kind of product) and the watertightness of the locks that prevent the air from entering the cyclone from below in vacuum cyclones. The average lifetime of a cyclone (replacement) is from 10 to 20 years.

Figure 2.44 shows the operational principle of a cyclone.

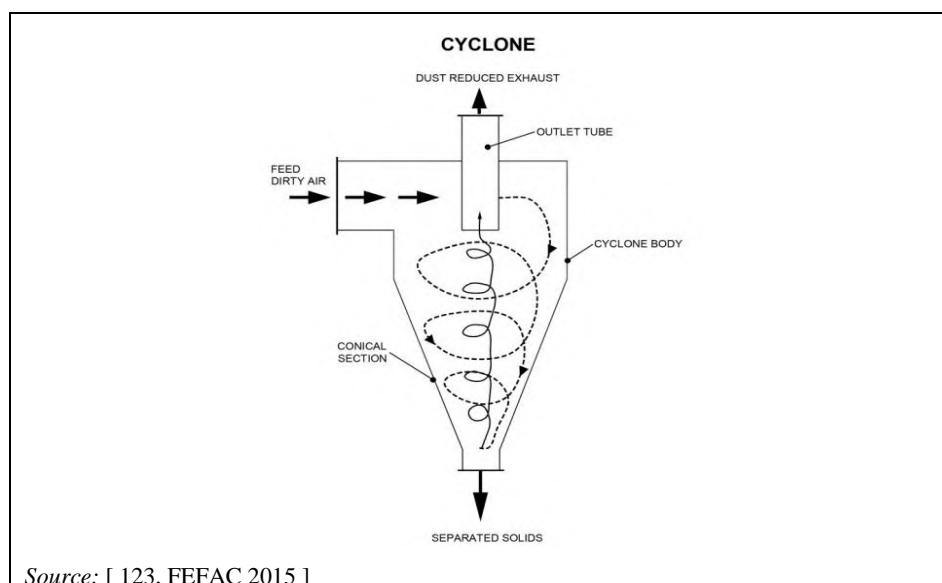

Figure 2.44: Operational principle of a cyclone

Cyclones are normally used to control particulate material of primarily $> 10 \mu\text{m}$. There are, however, high-performance cyclones designed to be effective even for particles as small as $2.5 \mu\text{m}$.

For high-performance cyclones, the working principle is the same as that of cyclones. The differences compared with traditional cyclones are the size and the proportion between width and length. High-performance cyclones have a more elongated shape. This shape allows the improvement of the rotational speed, so, as the diameter decreases, even the smallest particles of dust are separated from the air flow inside the cyclone. Additionally, a more accurate dimensioning of the cyclone related to the air flow can be achieved. The main controllable operating parameters are: pressure (mbar) and air flow (kg/h); their balance according to the given efficiency curve allows the best performance to be achieved.

Achieved environmental benefits

Reduction of dust emissions to air. Potential reuse of airborne materials.

Environmental performance and operational data

Cyclones are characterised by a simple and robust design, small space requirements and high operating reliability. Generally, the removed dust is sent back to the production process. Cyclones achieve better separation results than separators (see Section 2.3.7.2.1). Table 2.10 shows performance data of a cyclone, compared to other separation techniques.

More environmental performance and operational data are presented in the related FDM sectorial chapters.

Cross-media effects

By-products are produced for which further treatment may be required. Electrical energy is used to overcome the pressure drop in the cyclones. Also, the operation of cyclones is a source of significant noise.

Technical considerations relevant to applicability

Cyclones are applicable in new and existing installations. Only a small amount of space should be available to install the cyclone together with the air inlet and outlet ducts.

A minimum airflow is required to maintain operational performance. Regular inspection is performed to ensure that the interior of the cyclone is dry and that there is no accumulation of material which could affect the efficiency of the cyclone's operation.

Economics

This is a low-cost technique. Operating costs include the energy necessary for the pneumatic or hydraulic removal of the collected ash and electric power to compensate the waste gas pressure loss of the equipment. Maintenance costs are low given the durability of all of the components.

For a cyclone applied in an animal feed installation, an investment cost of EUR 26 000 was reported (purchase of cyclone and fan). Its annual operating cost was around EUR 51 000, related to 341 000 kW/year of electricity consumption [193, TWG 2015].

Driving force for implementation

Legislation is the main driving force.

Example plants

Cyclones are used in almost all the FDM sectors, see Table 2.8.

Reference literature

[35, Germany 2002], [92, Gergely E. 2003], [145, COM 2017], [193, TWG 2015]

2.3.7.2.4 Electrostatic precipitator

Description

Electrostatic precipitators operate such that particles are charged and separated under the influence of an electrical field. Electrostatic precipitators are capable of operating under a wide range of conditions. In a dry ESP, the collected material is mechanically removed (e.g. by shaking, vibration, compressed air), while in a wet ESP it is flushed with a suitable liquid, usually water.

Technical description

ESPs are used to separate solid or liquid particles from waste gases. The particles distributed in the gas are electrostatically charged so that they stick to collection plates. The main components of an ESP are the filter housing, the discharge and collecting electrodes, the power supply, the gas guides or baffles and a rapping system for cleaning the collecting plates. The separation process can be divided into the following individual stages:

- charging of the particles in the ion field;
- transport of the charged particles to the collecting plate;
- collection and film formation on the collecting plate;
- removal of the dust film from the collecting plate.

A distinction is made between dry and wet ESPs. These may have a horizontal or vertical gas flow. Dry ESPs are mostly built with collecting electrodes in plate form; they are also called plate ESPs. In wet ESPs, the collecting electrodes frequently take the form of tubes; here the gas flow is usually vertical. They are also called tube ESPs.

Figure 2.45 shows the typical arrangement of an electrostatic precipitator.

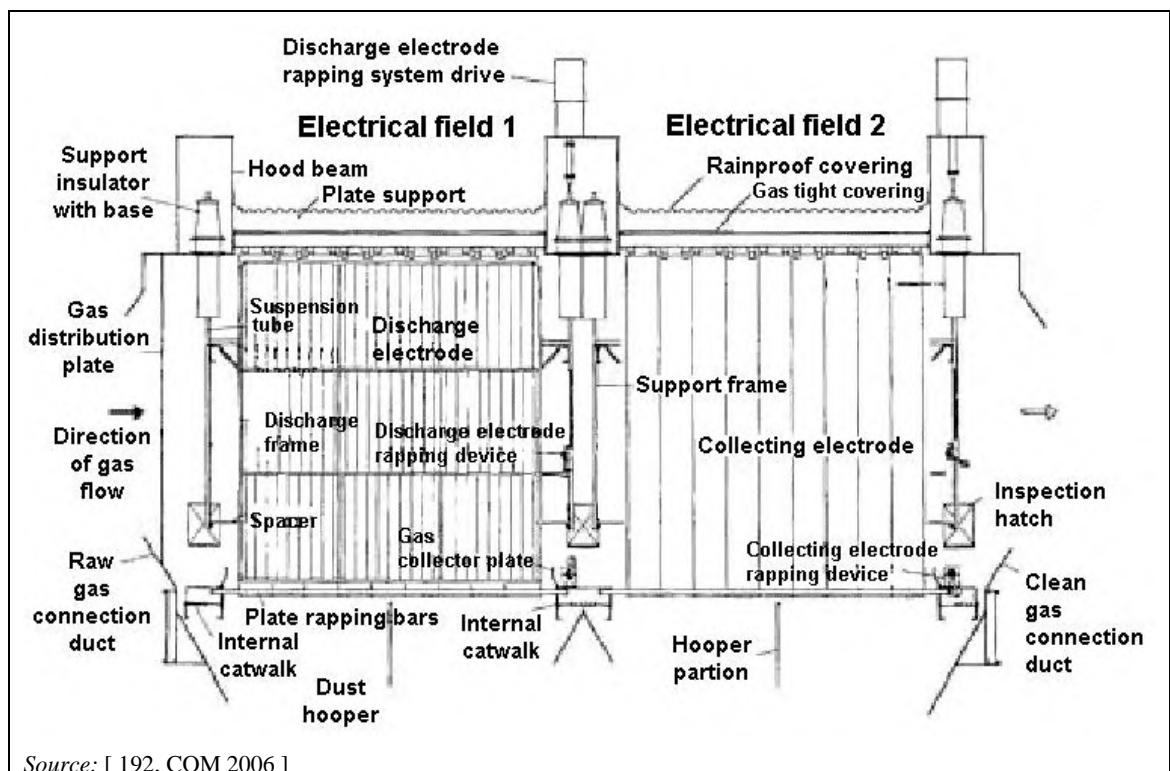

Figure 2.45: Typical arrangement of an electrostatic precipitator (only two zones shown)

Achieved environmental benefits

Reduction of dust emissions to air.

Environmental performance and operational data

Electrostatic precipitators permit separation rates of up to 99.9 %, effective separation of particles even lower than 0.1 μm , and treatment of waste gas volumes higher than 1 000 000 m^3/h [35, Germany 2002]. Table 2.10 shows performance data of this technique, compared to other separation techniques.

Table 2.64 shows installation-specific performance data related to the application of ESPs.

Electrostatic precipitators have low pressure losses, e.g. from 0.001 bar to 0.004 bar; low energy requirements, e.g. 0.05–2 $\text{kWh}/1\,000\,\text{m}^3$ and a long service life. Wet ESPs can achieve better separation rates than dry ESPs. In particular, they can separate fine dusts, aerosols and, to some extent, heavy metals and gaseous substances.

Table 2.64: Average values of periodic measurements of dust in dryer emissions after treatment in an electrostatic precipitator (dry basis)

Installation ID-point of release	FDM sector	Dust (mg/Nm^3)	O ₂ content (%)	Monitoring standard	Additional information
303-2	OI	11.80	16.00	EN 13284	<ul style="list-style-type: none"> • Sunflower seed, grapeseed • Combustion gases from steam generator and direct contact pomace dryer • Cyclone step before
303-1	OI	26.99	15.20	EN 13284	<ul style="list-style-type: none"> • Sunflower seed, grapeseed • Combustion gases from steam generator and direct contact seed dryer • Cyclone step before

Source: [193, TWG 2015]

Cross-media effects

Residue (fly ash) or liquid effluent (only in the case of wet ESPs) is produced which may require further treatment. Electricity is consumed. The high voltage of an ESP can introduce a new hazard.

Technical considerations relevant to applicability

ESPs are used for the removal of solid and liquid air pollutants, especially for fine dust. They are used in large systems for cleaning large quantities of waste gas at high temperatures. Wet ESPs are used for cleaning liquid-saturated gases, for acid and tar mists, or if there is a risk of explosion.

Economics

The cost of electrostatic precipitators includes costs due to electricity consumption, maintenance expenses and the transfer of the precipitated ash, but generally they are cost-effective devices for reducing dust emissions [145, COM 2017].

Driving force for implementation

Legislative demands for reduced emissions of fine particulate matter.

Example plants

This technique has been reported in an oilseed installation (#303) [193, TWG 2015].

Reference literature

[35, Germany 2002], [145, COM 2017], [192, COM 2006], [193, TWG 2015]

2.3.7.2.5 Packed bed filter

Description

Dust particles become attached to a granulated layer of gravel, sand, limestone or coke.

Technical description

The filter medium used in packed bed filters is typically a granular layer of gravel, sand, limestone or coke in the 0.3 mm to around 5 mm particle size range. During filtration, the dust particles become attached to the granulated layer. A dust layer which supports the separation process is formed at the surface of the bed. Penetration of the separated dust can be prevented by using fine particles (< 0.5 mm) and low flow speeds (< 0.1 m/s). However, there is a risk of bridge formation, which can result in reduced separation rates.

The packed bed may be up to several metres high. Cleaning is carried out by counterflow rinsing, mechanical shaking in conjunction with flushing air, or by movable nozzles while cleaning is taking place. Use of a multi-compartment filter design ensures continuous cleaning. Packed bed filters can be used to achieve the simultaneous separation of dust and gases. Packed bed filters satisfy an essential requirement for high-temperature or hot gas dedusting, namely utilisation of the thermal energy of the cleaned gas streams at a high temperature level.

Achieved environmental benefits

Reduced dust emissions to air.

Environmental performance and operational data

Filter separators can achieve high separation rates, e.g. > 99 %, with even very fine particles being separated very efficiently. Clean gas figures of around 10 mg/Nm³ for dust have been achieved in trials using packed bed filters, with an average dust content of 18 g/Nm³ in the dirty gas and a mean particle size of 0.5 µm.

The separation rate of packed bed filters is not as good as that of fibre layer filters. Packed bed filters are, therefore, used for separating problematical dust particles or separation at higher waste gas temperatures. Packed bed filters are frequently used in conjunction with preliminary separators, e.g. cyclones.

As a general rule, the average distance between fibres is considerably larger than the particles to be collected. The separation rates due to the screen effect are also supplemented by mass forces, obstructive effects and electrostatic forces.

Cross-media effects

No information provided.

Technical considerations relevant to applicability

Packed bed filters are suitable for the removal of dusts which are:

- hard and abrasive;
- at temperatures of up to 1 000 °C;
- mixed with chemically aggressive gases;
- combustible and where there is a risk of sparks;
- mixed with mists;
- mixed with some gaseous pollutants, e.g. SO₂, HCl and HF, when simultaneous separation can be achieved with suitable packing.

Economics

No information provided.

Driving force for implementation

Legislation is the main driving force.

Example plants

No information provided.

Reference literature

[35, Germany 2002]

2.3.7.3 Techniques mainly used to reduce organic/odour emissions

2.3.7.3.1 Wet scrubber

Description

The removal of gaseous or particulate pollutants from a gas stream via mass transfer to a liquid solvent, often water or an aqueous solution. It may involve a chemical reaction (e.g. in an acid or alkaline scrubber). In some cases, the compounds may be recovered from the solvent.

Technical description

Wet scrubbing (or absorption) is a mass transfer between a soluble gas and a solvent –often water– in contact with each other. Physical scrubbing is preferred for chemical recovery, whereas chemical scrubbing is restricted to removing and abating gaseous compounds. Physico-chemical scrubbing takes an intermediate position. The component is dissolved in the absorbing liquid and involved in a reversible chemical reaction, which enables the recovery of the gaseous component. Scrubbing or absorption is widely used as a raw material and/or product recovery technique for the separation and purification of gaseous streams which contain high concentrations of VOC, especially compounds soluble in water such as alcohols, acetone or formaldehyde. The use of absorption as the primary control technique for organic vapours is subject to the availability of a suitable solvent, with a high solubility for the gas, low vapour pressure and low viscosity.

Wet dust scrubbing is a variation of wet gas scrubbing using the same or equivalent techniques to abate or recover dust in addition to gaseous compounds. A type of scrubber widely operated for dust abatement is the venturi scrubber.

Different types of wet scrubbers can be distinguished by classifying them in terms of their design features. Some examples are:

- absorption techniques such as scrubber towers, spray scrubbers (see Table 2.65);
- injection scrubbers, e.g. high-pressure or dual-substance injection scrubbers;
- jet scrubbers;
- vortex scrubbers;
- rotary scrubbers, disintegrators (high performance);
- venturi scrubbers (high performance).

A spray scrubber simply comprises a liquid spray which comes into contact with a rising airstream within a vessel. The vessel contains no packing or plates or any device used to enhance gas-liquid contact. A typical spray tower configuration is shown in Figure 2.46.

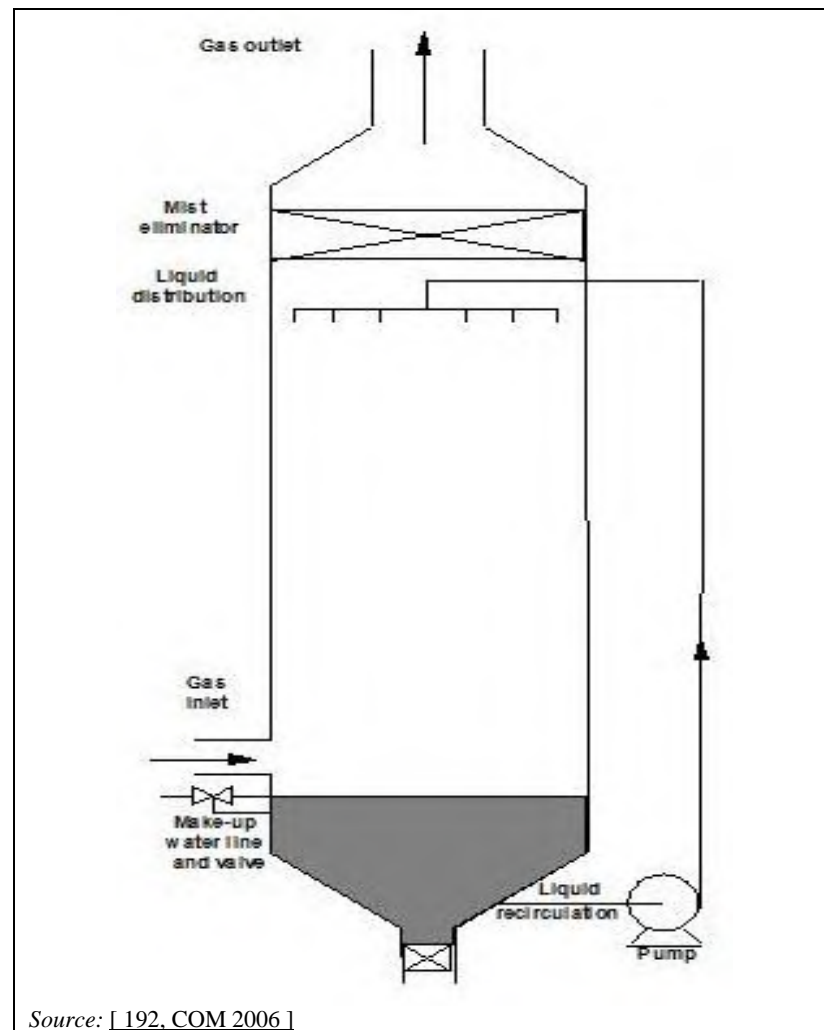
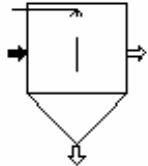
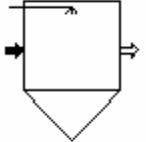
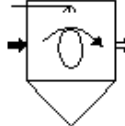
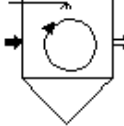
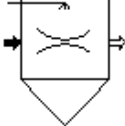

Figure 2.46: Spray chamber layout

Regarding the venturi scrubber, the characteristic feature is the constriction of the duct –venturi throat– causing an increase in gas velocity. Liquid is introduced into the scrubber and forms a film on the walls, which is atomised by the gas stream in the venturi throat. Alternatively, with ejector venturi scrubbers, the liquid is sprayed into the venturi throat.

An example of design standards for wet scrubbers used in Germany according to DIN standards is shown in Table 2.65.

Table 2.65: Dust removal from air – overview of wet scrubbers

Description	Scrubber tower Spray scrubber Packed bed absorber	Injection scrubber (high- pressure or dual-substance injection scrubber)	Jet scrubber	Vortex scrubber	Rotary scrubber, disintegrator	Venturi scrubber
Symbols according to DIN 30600/28004			-			
Gas speed in contact zone in relation to free cross-section (m/s)*	1–5	20–60	5–15	8–20	25–70	40–150
Pressure difference over entire separator (bar)*	1–25	5–25	Pressure recovery of approximately 1–10	15–30	2–10 ⁽¹⁾	30–200
Energy requirements (kWh/1 000 m ³)	0.2–3	0.4–2	1.2–3	1–2	4–15 ⁽¹⁾	5–15
Collecting liquid/gas ratio (l/m ³)*	1–5	0.5–5	5–50	No data possible due to process principle	1–3 per stage	0.5–5
Separation limit (µm)*	0.7–1.4	0.1–1	0.8–0.9	0.6–0.9	0.1–0.6	0.05–0.5
Dust separation rate (%)* ⁽²⁾	50–85	90–95	90–95	90–95	92–96	96–98
NB: * Approximate values; higher or lower variations are possible. ⁽¹⁾ In disintegrators, the energy consumption is often considerably higher depending on the efficiency and the volume of gas handled. A pressure recovery of up to 25 bar is possible. ⁽²⁾ The separation rate shown in the table merely gives a rough idea of the possible working range. Although the separation rate is easy to measure, it only permits limited conclusions about the efficiency of a separator. For example, it is directly dependent on the particle size distribution of the input material. If the particle size distribution changes, so does the separation rate, even if the other parameters remain constant. A knowledge of the separation rate does, however, become important in the specific application. The fraction separation rate is a much more suitable parameter for assessing the efficiency of a separator. Source: [136, Deutsches Institut für Normung p.v. 2005]						

Achieved environmental benefits

The major environmental benefits of the application of wet scrubbers are:

- reduction of gaseous pollutants, such as SO₂, ammonia, or volatile organic compounds and reduction of odour emissions;
- reduction of dust emissions;
- recovery of the product, e.g. in vegetable oil processing, the collected dust is recovered and can be added back to the meal;
- prevention of fire risk.

Environmental performance and operational data

Using wet scrubbers, it is possible to achieve dust separation rates of 80–99 %.

The techniques to consider in the determination of BAT of the FDM sectorial chapters (see Chapters 3 to 15) contain installation-specific performance data related to the application of wet scrubbers.

Cross-media effects

Energy consumption. Waste water production.

Technical considerations relevant to applicability

The technique is applied throughout the FDM sector.

Economics

The cost of waste water treatment may be considerable, in some cases even higher than for measures to control dust emissions.

Driving force for implementation

Wet scrubbers are used for the removal of solid and liquid air pollutants, particularly in cases:

- of flammable or sticky dust;
- where there is a risk of explosion;
- for the simultaneous separation or preliminary separation of solid, liquid and gaseous pollutants;
- for small dust particles (< 0.1 µm).

Example plants

See Table 2.8.

Reference literature

[35, Germany 2002], [16, Willey et al. 2001], [154, COM 2015], [136, Deutsches Institut für Normung p.v. 2005], [192, COM 2006], [193, TWG 2015]

2.3.7.3.2 Plate absorber**Description**

Plate absorbers consist of a vertical tower with several horizontal perforated trays or sieve plates stacked in it. The scrubbing liquid enters the top of the tower, while the airstream to be treated enters the bottom of the tower and flows upwards.

Technical description

Plate absorbers consist of a vertical tower with several horizontal perforated trays or sieve plates stacked in it. Baffles are situated a short distance above the apertures in the plates. Scrubbing liquid enters the top of the tower and successively flows along each of the trays. The airstream to be treated enters the bottom of the tower and flows upwards, passing through perforations in the plates. The velocity of the airstream is sufficient to prevent liquid seeping through the perforations. The airstream to be treated is directed through the falling curtains of liquid

overflowing the trays. There are many variations in the plate design and positioning of the liquid nozzles. The plate absorber system is shown in Figure 2.47.

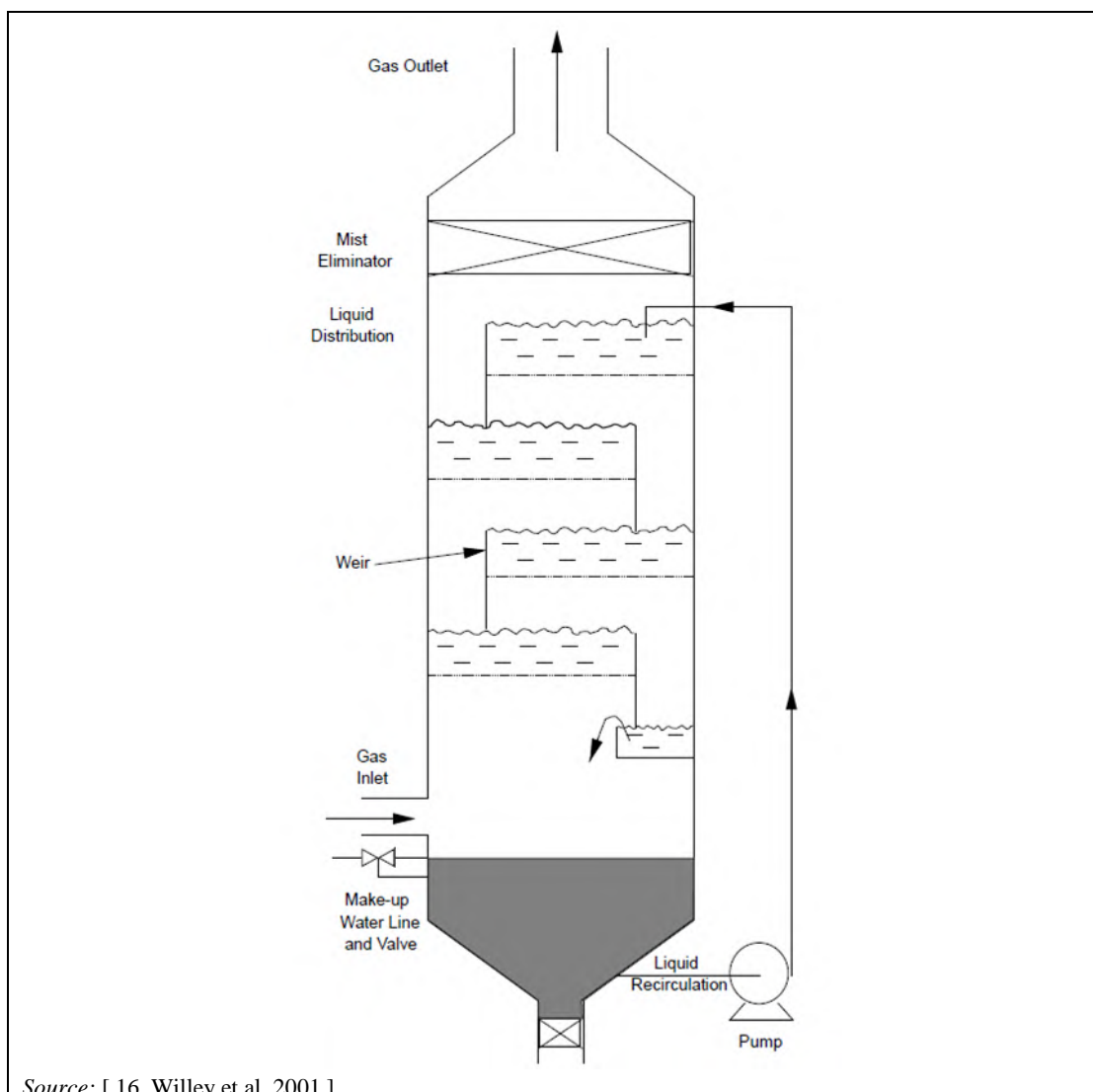

Source: [16, Willey et al. 2001]

Figure 2.47: Plate absorber layout

Achieved environmental benefits

Removal of odours, gaseous components and dust from air.

Environmental performance and operational data

Absorbers, in general, are reported to have the advantage of having a relatively low pressure drop. They are reported to be more effective for the removal of specific components rather than overall removal and they have a reported efficiency of typically 70–80 %.

The equipment is compact, so absorbers do not take up much space, but they may require space for the safe storage of chemicals.

Cross-media effects

Waste water is generated. Likely to generate a visible plume at the hot gas outlet.

Technical considerations relevant to applicability

In general terms, absorbers are suitable for a wide range of volumetric airflows which contain gases and/or odours in relatively low concentrations.

Economics

The technique is relatively inexpensive, compared to other end-of-pipe odour control techniques. The capital and operating costs are relatively low. Plate absorbers' cost-effectiveness is reduced if the exhaust gas to be treated has a high moisture content, due to their preferential absorption of water vapour.

Driving force for implementation

No information provided.

Example plants

No information provided.

Reference literature

[16, Willey et al. 2001]

2.3.7.3.3 Adsorption**Description**

Organic compounds are removed from a waste gas stream by retention on a solid surface (typically activated carbon).

Technical description

Adsorption is a unit process involving the capture of airborne components onto a fine particulate active surface. There are a number of possible active materials that are used for general applications, including zeolites, silicas, polymeric resins and activated carbon. The activated carbon is the most frequently chosen adsorbent within the FDM sector and hence the term carbon adsorption is commonly used.

Carbon adsorption is a dynamic process in which vapour molecules impinge on the surface of the solid and remain there for a period of time before desorbing again into the vapour phase. An equilibrium is established between adsorption and desorption, i.e. a particular concentration of a compound on the carbon surface corresponds to a concentration or partial pressure of that compound in the gas phase.

The adsorption process can be either physical, in which case the adsorbed molecules are held to the surface by van der Waals forces, or chemical, where chemical bonds are formed between the adsorbed molecules and the surface. Both of these processes release heat, the latter rather more than the former.

Activated carbon can be made from a variety of carbonaceous materials, including wood, coal, peat, nutshells, lignite, bone and petroleum residues. Shell- and coal-based products are usually used in vapour phase applications. The manufacturing process consists of the dehydration and carbonisation of the raw material, which drives off the volatile matter and produces a rudimentary pore structure. This is followed by thermal or chemical activation. Activated carbon used in odour control applications has the typical properties shown in Table 2.66.

Table 2.66: Properties of activated carbon

Parameter	Units	Property
Particle size	mm	1.4–2.0
Bulk density	kg/m ³	400–500
Surface area	m ² /g	750–1 500
Pore volume	cm ³ /g	0.8–1.2
<i>Source:</i> [192, COM 2006]		

Carbon beds can either be used once and disposed of, or regenerated. Regenerative systems are typically used in installations where the recovery of the material being captured is economically attractive. It is more common to use a single fixed bed adsorber system. Regenerative systems are usually designed with multiple beds so that adsorption and desorption can be conducted simultaneously. It is usually necessary to raise the temperature of the adsorbent bed to release the adsorbate, with steam being the most commonly used medium. A regenerative system therefore requires an additional capture mechanism for materials desorbed during the regenerative process.

The fixed bed system comprises a bed of activated carbon through which the gas stream to be treated is passed. The carbon is in either a simple packed bed arrangement or in the form of carbon filters. The filters are essentially paper or cardboard cartridges containing powdered activated carbon. In general, the cartridge arrangement is used for general room ventilation whilst the packed bed system is used for odour control from process exhausts. Once the activated carbon has expired, e.g. as judged by an increased outlet odour level, the carbon or cartridge arrangement needs to be replaced. The packed bed system has the advantage that, in most cases, it can be returned to the supplier for regeneration at his premises whilst the cartridge filters are usually disposed of by the user.

The design basis for room ventilation using cartridge filters is significantly different from that for process odour control using packed beds. In general, cartridge filters are employed for small vent flows of intermittent or infrequent nature with very low sorbent concentrations. Conversely, the packed bed system is used where the concentration of components in the airstream to be treated is significantly higher than typical room or factory floor concentrations. The major difference in the design basis of each system is the residence time; with room ventilation requiring only 0.1 to 0.2 seconds, and process exhaust treatment requiring between 1 and 3 seconds. The choice of residence time is essentially a compromise between the physical volume of the designed bed and the time between renewals. Table 2.67 shows the principles of operation of the three major types of adsorbers.

Table 2.67: Principle of operation of the main types of adsorbers

Adsorber	Principle of operation
Fixed bed unsteady state adsorber	The contaminated gas passes through a stationary bed of adsorbent
Fluidised bed adsorber	The contaminated gas passes through a suspension of adsorbent
Continuous moving bed adsorber	The adsorbent falls by gravity through the rising stream of gas
<i>Source: [192, COM 2006]</i>	

In general, the lower the temperature, the greater the amount adsorbed and, therefore, the longer the penetration time or bed life. As a guideline, carbon adsorption is not applicable at a temperature above 40 °C. Furthermore, the efficiency of activated carbon is reduced at a relative humidity above 75 %, except for water-soluble compounds such as the lower amines and hydrogen sulphide. This preferential adsorbance of water can lead to condensation within the bed, so making the carbon inactive. The bed would then require drying out before it could be reused.

Achieved environmental benefits

Reduction of TVOC and odour emissions to air.

Environmental performance and operational data

The installation of a carbon adsorption system is fairly simple, comprising a fan and vessel to hold the carbon bed. Carbon adsorption can give odour removal efficiencies of 80–99 % [16, Willey et al. 2001].

The absorptive capacity of activated carbon is expressed as weight-% in terms of the amount of the specified material that can be adsorbed per unit mass of carbon. These figures vary considerably from as low as zero to as high as 110 % and are fairly meaningless for an odorous exhaust potentially containing a wide variety of individual components. In this sense, as a general guideline, a value of 30 % can be used to estimate the expected lifetime of a carbon bed used in the FDM sector.

Cross-media effects

Energy consumption. Waste is produced when the activated carbon needs to be disposed of.

Technical considerations relevant to applicability

Carbon adsorption is generally suitable for low air throughputs of less than 10 000 m³/h and where the contaminant to be removed is present in a low concentration, e.g. less than 50 mg/Nm³. In terms of odour control, the major applications of carbon adsorption are the cleaning of ventilated air and the treatment of odorous process emissions.

The presence of dust in the gas stream to be treated can seriously interfere with the efficiency of a carbon bed, as well as increase the operating pressure drop. The dust and condensables can be removed in a pre-filter arrangement, although this will add to the complexity and cost of the unit as well as adding operational problems in cleaning requirements and dust breakthrough.

Economics

This technique has relatively low capital costs. The operational cost is high, e.g. carbon costs approximately EUR 2 400/t. Regeneration is not normally economical, so the carbon bed has to be totally renewed when its adsorption efficiency begins to fall, which might be after only a short period of time depending on the odour emission rate and odorant concentration [16, Willey et al. 2001].

Driving force for implementation

No information provided.

Example plants

This technique has been reported in a meat processing installation (#331) [193, TWG 2015].

Reference literature

[16, Willey et al. 2001], [192, COM 2006], [193, TWG 2015]

2.3.7.3.4 Biofilter

Description

The waste gas stream is passed through a bed of organic material (such as peat, heather, compost, root, tree bark, compost, softwood and different kinds of combinations) or some inert material (such as clay, activated carbon, and polyurethane), where organic (and some inorganic) components are transformed by naturally occurring microorganisms into carbon dioxide, water, other metabolites and biomass.

Technical description

In biofilters, the pollutants are adsorbed onto the filter material and degraded by the microorganisms located on a fixed filter medium. The filter material is arranged in the form of a packed bed and is permeated by the waste gases. For waste gases with high dust emission levels, the gas needs to be passed through a dust remover, before the biofilter.

Biofilters can be operated in either downflow or upflow fashion. The relative merits of each mode are uncertain and it is most likely that operational efficiency is the same in each case. The pressure drop over a biofilter is low, typically in the range of 10 mm/m to 25 mm/m of packed height. This low pressure drop infers that proper design of the air distribution for either

downflow or upflow installations is a critical design parameter. A typical layout of a biofilter is illustrated in Figure 2.48.

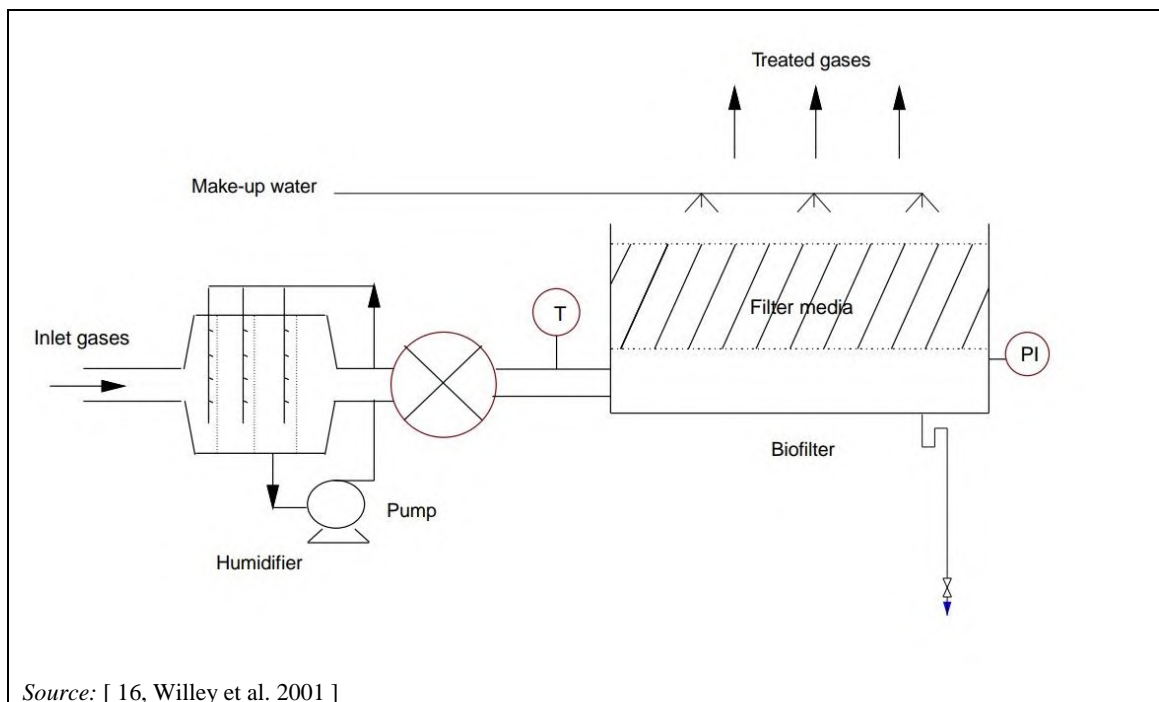

Source: [16, Willey et al. 2001]

Figure 2.48: Biofilter layout

The waste gas to be treated is directed initially into a humidifier, where it is countercurrently put into contact with recirculating water. The air exiting the humidifier is subsequently directed to the biofilter.

It is not normal practice to operate the humidifier with a continuous fresh supply of make-up water as this would lead to a waste water discharge requirement.

Periodic irrigation of the top of the bed allows the system to maintain the required moisture content in the filter material of 40–60%. Any water falling through the bed, via irrigation or rainfall, can be recycled to the humidifier to avoid a waste water discharge from the system.

There is a wide variety of filter materials that have been used in biofilters. The major requisites of the filter material are a high specific surface area, e.g. 300–1000 m²/m³, a high water-bearing capacity, limited compaction characteristics and a limited resistance to flow. Traditionally, fibrous peat mixed with heather in a 50% proportion has been used. The microbial activity occurs within the peat whilst the heather provides a stiffening agent to prevent compaction, thereby extending the operating life of the bed.

A variation of the peat/heather mixture is mushroom compost mixed with 5 mm diameter polystyrene spheres for support, in a 50% proportion. Rootwood is typically comprised of tree roots, branches and loose twigs. The rootwood is split into lengths of typically 15 cm by a tearing apart action rather than straight cuts. This action effectively exposes the maximum surface area and does not require supporting material. These filter media have all been proven in full-scale installations. Specific operating experience may be sought if any other materials are proposed.

Biofilters can be further subdivided into soil- and non-soil-based biofilters. The soil-based biofilter or soil bed comprises a layer of porous soil under which is a network of pipes through which the airstream to be treated is passed. An open structured soil is required to keep the pressure drop across the bed to a minimum.

In general, the residence time required for a biofilter depends upon the level and type of contaminants present in the airstream to be treated. Components that are aromatic in nature will require a longer residence time than more simple organic chemicals. As a general guideline, a minimum residence time of 20 seconds is chosen, extended up to 40 seconds where contaminants with reduced biological degradability are present.

The velocity through the filter bed is typically between 0.02 m/s and 0.05 m/s. The surface loading rate, which is often used to characterise a design, is typically within the range of 100–250 m³ gas/m² filter area/h.

Due to reasons of potential compaction, the maximum height of the filter media is restricted to approximately 1.0–1.5 metres. Where a greater height is required due to limited land availability, then some form of intermediate support would be required within the vertical cross-section of the bed.

The distribution of air through the biofilter is an important consideration and a plenum chamber design is recommended. In this respect, the vertical height of the plenum chamber is at least 50 % that of the height of the filter material.

The pH of the filter material in a biofilter is typically maintained between 6.5 and 7.5, a range preferred by most bacteria. In some cases, the biodegradation of exhaust gas components can generate acidic by-products, so dosing with alkali may be undertaken.

Important characteristics of the filter material include a low pressure loss, a high buffering capacity and a wide spectrum of microorganisms present. Approximately 40 % to 60 % moisture content of the filter bed is needed to ensure good efficiency. The filter bed needs regular maintenance, e.g. to be kept free of plant growth, settled material and gas breakthroughs, to ensure its optimal effectiveness.

A typical lifetime of a filter bed of 3 to 5 years is often quoted; however, for most filter materials, and particularly for peat/heather, the bed will require topping up within the first 18 months of operation. A complete replacement of the material is only necessary if the degradation of the organic matter has proceeded to such an extent that the required air flow rate can no longer be achieved. To enable replacement of the filter material, the equipment has to be designed and constructed such that the grid is accessible for vehicles or the filter can be maintained with a mobile gripper. If the biofilter is divided into several segments, the entire production does not need to shut down for maintenance work.

Depending on the nature of the upstream process, an emergency gas vent to the air can be installed linked to a temperature sensor located at the inlet to the biofilter. The control mechanism is set such that if the biofilter inlet temperature exceeds 45 °C over a predetermined period of time, say 4 hours, the exhaust gases are discharged directly to the air, thereby bypassing the biofilter. The use of such a system will mean that the waste gases are emitted untreated, so the conditions leading to such a bypass need to be prevented. Local temperature and bed pressure drop indicators are also recommended.

Dust and fats may need to be removed upstream of the filter to avoid potential clogging, leading to a rise in filter pressure drop and a reduction in operational efficiency.

Soil beds are normally constructed below ground, so care needs to be taken to ensure that the base of the soil filter is above the water table. The major disadvantage with the soil biofilter is the excessive residence time required for the biological process, which is in the region of 5 minutes. This results in very large open structures requiring significant land area.

Biofilters have also been used to treat frying exhaust gases. The vapour of the deep fryer is condensed in a condensation unit. This leads to a reduction of the odour and a reduction of the vapour volume. Afterwards, the vapour is sent through a biofilter. Oil and fat will be removed

by bio-organisms. The temperatures in these new-generation filters are up to 60 °C. At these temperatures, thermophilic bacteria are active. The removal rate is higher in these biofilters, which leads to a smaller design, reduced growth of bio-organisms and lower pressure drop. However, the filter is replaced more frequently than in cases where mesophilic bacteria are used (operating at 20–40 °C). The filter is kept wet enough for the bio-organisms.

Achieved environmental benefits

Reduced emissions to air, mainly odour/TVOC.

Environmental performance and operational data

A correctly operating biofilter will exhibit an outlet odour concentration of typically 150–200 OU_E/m^3 . The characteristic smell associated with the treated discharge is a musty, moist forest type with very little resemblance to the inlet odour. Odour removal efficiencies of up to 99.5 % can be achieved, although the removal percentage is very dependent upon the inlet concentration. It is unlikely that an outlet odour level of less than 150 OU_E/m^3 can be achieved so an inlet odour level of 5 000 OU_E/m^3 would represent a maximum efficiency of 97 % [35, Germany 2002].

TVOC abatement efficiencies of 80–90 % have been reported.

The use of specially composted organic material, leca (expanded clay) or moler (expanded clay) leads to odour abatement efficiencies > 95 % and increased biofilter lifetimes (in some cases more than 10 years) [224, Denmark 2015].

More environmental performance and operational data are presented in the related FDM sectorial chapters.

Cross-media effects

These include generation of acidic by-products, e.g. from the biodegradation of exhaust gas components. Disposal of the filter material is also necessary. In some cases, used material is composted to reduce the organic pollution and then sent for landspreading. Condensation water is recycled; otherwise it requires treatment. Energy consumption is required for the pump to overcome the resistance of the filter media.

The use of biofilters in FDM installations producing ready meals and ice cream may increase hygiene risks, due to the bacterial population in the filter material.

Technical considerations relevant to applicability

The biofiltration process is suitable for a wide range of airflows, up to and exceeding 100 000 m^3/h , providing there is sufficient land space available. A limit to the maximum concentration of contaminants in the inlet airstream is generally documented as less than 5 000 mg/Nm^3 , although a concentration limit of 1 000 mg/Nm^3 may be used as a guideline when assessing the suitability of biofiltration.

Biofilters are suitable for ventilation systems where a constant airflow is extracted from a vessel or process room. Periodic heavily contaminated airstreams are avoided unless there is sufficient dilution from other sources being treated.

This technique is not applicable for airborne temperatures in excess of 40 °C. If temperatures above 40 °C are prevalent for significant periods of time, i.e. greater than 4 hours, then the microorganisms present in the filter become sterilised and the bed requires reseeded. At temperatures below 10 °C, the rate of biological degradation falls dramatically. This technique is not applicable for humidities lower than 95 %.

Economics

Relatively high odour removal efficiency at relatively low cost compared with alternative treatment techniques. The capital cost of the downflow system is higher than for the upflow system as it will require an airtight top seal. This would be emphasised for a larger biofilter.

The specific investment costs for biofilters of modular construction depend on the size of the plant and the construction standard. For smaller plants, i.e. 200–500 m³/h, the cost is about EUR 45–50/m³ of exhaust air. In larger plants, costs may go down to EUR 10–15/m³. These costs do not include exhaust air interception and the necessary construction costs [35, Germany 2002].

The operating costs are largely made up of the energy costs for running ventilators and humidifier pumps. There are also costs associated with the water required for humidification, the maintenance of the biofilter and the replacement of filter material at the end of its service life. The energy costs amount to EUR 0.15–0.225/1 000 m³ of exhaust air, calculating electricity costs at EUR 0.15/kWh. Including the above-listed additional costs, the price for the treatment of 1 000 m³/h exhaust air then amounts to EUR 0.225–0.30 [35, Germany 2002].

Soil beds have a potentially high odour removal efficiency at a relatively low cost when compared with alternative treatment techniques.

Driving force for implementation

To prevent complaints about odours and to meet legal requirements.

Example plants

This technique has been reported in several installations from the dairy, meat processing and oilseed sectors, as shown in Table 2.8 [193, TWG 2015].

Reference literature

[16, Willey et al. 2001], [35, Germany 2002], [154, COM 2015], [193, TWG 2015], [224, Denmark 2015], [229, Belgium-VITO 2015]

2.3.7.3.5 Bioscrubber

Description

A packed tower filter with inert packing material which is normally continuously moistened by sprinkling water. Air pollutants are absorbed in the liquid phase and subsequently degraded by microorganisms settling on the filter elements.

Technical description

Bioscrubbers (or biotrickling filters) are absorbers in which an intensive exchange of substances takes place between the polluted gas and the absorbent. The microorganisms are either finely divided in the collecting liquid or applied as a layer to the absorber structures or trickling filter. The absorber is followed by a mist collector to separate the gaseous and liquid phases. In the subsequent absorbent regeneration step, the waste gas constituents absorbed in the liquid phase are removed from the absorbent. For waste gases with high particulate emission levels, the gas needs to be passed through a dust remover before the bioscrubber.

The technique essentially comprises a packed bed absorber containing a bacterial population within the packing and the sump. The contaminated gas is passed up the tower against a flow of water containing a population of bacteria. The bacteria attaches itself to the packing in a similar manner to a trickling filter used for waste water treatment (see Section 2.3.6.2.1.5). Nutrients, required for bacterial growth and synthesis, are added to the absorber sump on a periodic basis.

The speed of biodegradation is relatively slow, thus operating conditions may have a crucial role. A bioscrubber operates at a typical residence time of 5–15 seconds, depending on the airstream to be treated. Bioscrubbers require a much smaller land area than biofilters. A typical layout of a bioscrubber installation is shown in Figure 2.49.

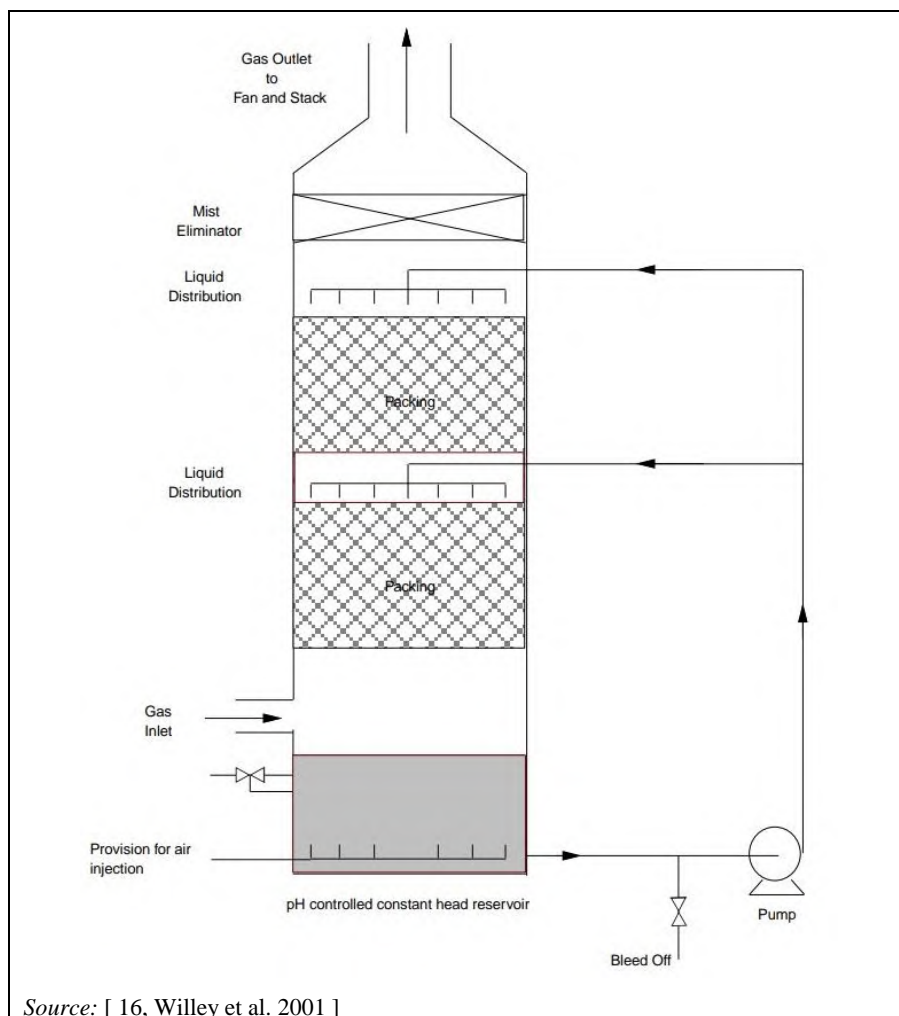

Figure 2.49: Bioscrubber layout

Achieved environmental benefits

Reduced emissions to air, mainly odour, TVOC, SO₂ and dust.

Environmental performance and operational data

The size of a bioscrubber is not restricted by the airflow to be treated, although the resultant size of a single packed tower may necessitate two parallel systems. A limit to the maximum concentration of contaminants in the inlet airstream is generally documented as less than 5 000 mg/Nm³, although a concentration limit of 1 000 mg/Nm³ may be used as a guideline when assessing the suitability of bioscrubbing [35, Germany 2002].

More environmental performance and operational data are presented in the related FDM sectorial chapters.

Cross-media effects

The bioscrubber is more energy-intensive than the biofilter as water is being recirculated in addition to the air movement. Disposal of the filter material.

Technical considerations relevant to applicability

Used to eliminate biodegradable gaseous air pollutants, especially organic pollutants and odours. In theory, a bioscrubber can be used wherever bio-oxidation is an appropriate solution to an emission problem and its applications are, therefore, similar to those of biofilters; however, biofilters are more widely applied. This technique is not applicable for airborne temperatures in excess of 40 °C.

Economics

A relatively high odour removal efficiency at relatively low cost when compared with alternative treatment techniques.

Driving force for implementation

- Reduction of odour emissions.
- Meeting H₂S emission requirements.

Example plants

See Table 2.8.

Reference literature

[16, Willey et al. 2001], [35, Germany 2002], [192, COM 2006], [193, TWG 2015]

2.3.7.3.6 Thermal oxidation**Description**

The oxidation of combustible gases and odorants in a waste gas stream by heating the mixture of contaminants with air or oxygen to above its auto-ignition point in a combustion chamber and maintaining it at a high temperature long enough to complete its combustion to carbon dioxide and water.

Technical description

For complete oxidation of the compounds to be degraded in the airstream, it is necessary for them to be in contact with sufficient oxygen for a long enough time and at a high enough temperature. Rapid oxidation of organic compounds will occur if the gas temperature in the thermal oxidiser can be maintained at 200–400 °C higher than the auto-ignition temperature of the chemical species present. In thermal oxidation, the pollutant conversion takes place at high temperatures, e.g. > 600 °C. Thermal oxidisers do not operate effectively until they reach the combustion temperatures of the pollutants they are used to destroy, so they need to be started up before they are actually required.

In addition to considering the applicability of thermal oxidation to the components to be destroyed, it is important to consider the recovery of heat from the thermal oxidation process to reduce fuel costs. As FDM emissions to air seldom have organic concentrations in the region of the lower explosive levels, the conventional type of thermal oxidisers, which have direct flame contact with the airstream to be treated, are mostly used. In cases where there is a high concentration of organics above the relevant explosive limits, then a flameless type of system may be required. These systems use a heating medium to heat the airstream and, thus, avoid direct contact of the airstream with the flame.

Direct flame thermal oxidisers usually operate at temperatures of between 700 °C and 900 °C. The reaction temperature depends on the nature of the pollutant; it may be lower, but for less readily oxidisable substances such as organohalogen compounds it may be in excess of 1 000 °C. For odorous compounds, a temperature of 750–800 °C is generally adopted. The conditions of the equipment stages of a thermal oxidiser are illustrated in Table 2.68. A typical layout of a thermal oxidiser is shown in Figure 2.50.

Table 2.68: Conditions at different stages of thermal oxidation

Equipment stages	Conditions
Burning	The fuel is burned with clean air or with a proportion of the contaminated air to produce a flame at a temperature of typically 1 350–1 500 °C
Mixing	To ensure adequate turbulence and hence mixing of the process gas to bring it to uniform temperature
Combustion	The gases are held at the combustion temperature until oxidation has been completed, typically 0.5 to 1.0 seconds
Heat recovery	Reduces operating costs and fuel consumption

Source: [192, COM 2006]

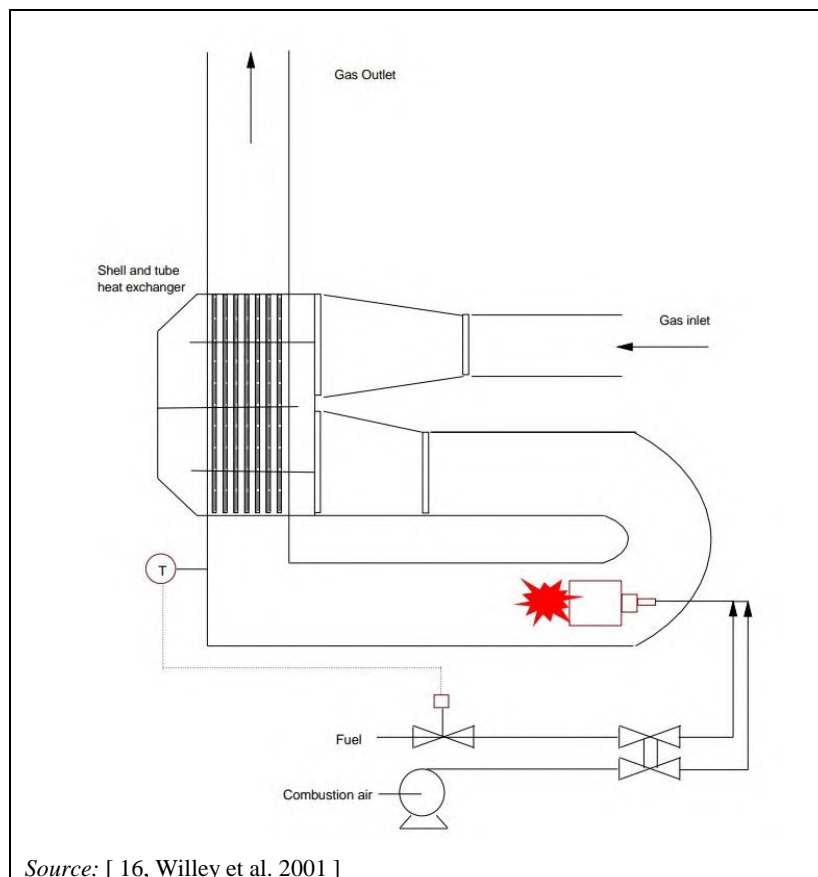

Figure 2.50: Thermal oxidiser layout

Burners can be divided into those with a single flame and those in which the fuel is distributed between a large number of jets. With regard to the shape, laminar-flow, nozzle and vortex burners are possible. In special cases, the burner may be replaced by an electric heating system. The oxygen required for combustion can be taken from the air, the airstream to be treated, or alternatively from a proportion of each. Possible supplementary fuels include light heating oil, natural gas or LPG. Care needs to be taken and due vigilance paid to the potential for any water vapour present in the airstream to quench the flame, thereby resulting in poor combustion. The burner may also be of the pre-mix type where the fuel is mixed with the combustion air prior to passing through the nozzles, or a diffusion type where the fuel is mixed with the combustion air downstream of the nozzles. Most burners are of the diffusion type.

The mixing of the gas stream may be achieved in a variety of ways; by natural diffusion, impingement mechanisms, or by the inclusion of baffles to induce flow changes. Suppliers offering low- NO_x systems often incorporate various backmixing sections, with the intention of reducing temperature increases significantly above the mixed temperature.

The combustion chamber in which the oxidation reaction takes place is designed for high thermal stresses. Some combustion chambers are made of heat-resistant metal and chambers with a metal jacket and refractory lining. The dimensions of the combustion chamber are sufficient to achieve the desired residence time and to accommodate the physical length of the flame without quenching.

Some form of heat recovery is nearly always warranted to reduce operating costs and fuel consumption. Heat recovery is conventionally conducted in a shell and tube heat exchanger, which allows heat to be continuously transferred to preheat the incoming gas stream. This type of system is termed a recuperative system, with 70–80 % heat recovery being a typical design level.

Heat recovery can also be achieved in a regenerative system, which uses two sets of ceramic bed heat exchangers. There, one bed is heated by direct contact with the exhaust gas while the other is used to preheat the incoming gases. The system is operated so that the beds alternate between heating and cooling. The heat recovery potential of this system is higher than the recuperative system, with 80–90 % heat recovery being a typical design basis. The use of thermal fluids is an alternative to this type of system.

Achieved environmental benefits

Reduced TVOC and odour emissions.

Environmental performance and operational data

A properly designed and operated thermal oxidiser can achieve odour removal efficiencies approaching 100 %. The performance of this technique is independent of the intensity of the odour emissions. Thermal oxidation of waste gases can achieve TVOC emission levels of $< 1\text{--}20 \text{ mg/m}^3$ [168, COM 2016].

More environmental performance and operational data are presented in the related FDM sectorial chapters.

Cross-media effects

The oxidation process has the potential to generate unwanted by-products of combustion, e.g. high emission levels of NO_x and CO_2 . Essentially, the higher the reaction temperature then the greater the potential for the generation of increased emission levels of NO_x . It is usually beneficial to opt for a low- NO_x burner.

Any compounds containing sulphur present in the odorous gas stream will generate SO_2 emissions and the potential for minimising this should be considered. The presence of chlorides in the odorous airstream may need to be reviewed due to the potential formation of acidic gases such as HCl. As well as leading to emissions, there could be potential corrosion problems within the equipment. When halogenated VOC is present, special conditions to suppress the formation of dioxins may be required, though normally there is negligible dioxin formation during the combustion of waste gas streams [168, COM 2016].

Another cross-media effect is energy consumption, e.g. consumption of fuel for operating the oxidiser.

Technical considerations relevant to applicability

Thermal oxidation has the advantage of being almost universally applicable as a method of odour control because most odorous components can be oxidised to non-odorous products at a high temperature, whereas the application of other methods are more restrictive.

Thermal oxidation is generally used for the treatment of air volumes of less than $10\,000 \text{ Nm}^3/\text{h}$, having increased costs for heating greater volumetric airflows. It is suitable for odorous streams with variable contaminant concentrations and is capable of treating a variable volumetric throughput.

If alkali metals are present from the soil in vegetable drying installations, they may cause premature degradation of the ceramic media used for regenerative heat recovery.

Odorous airstreams containing significant quantities of particulate material generally require pretreatment prior to the thermal oxidation process. This is particularly relevant if a heat recovery system is installed, due to a potential fouling of the heat exchanger.

Whilst the presence of high levels of water vapour in an airstream is not considered a process problem, the fuel requirements are greater than for heating dry air. In practice, the removal of water vapour from an airstream is usually not undertaken and additional fuel requirements are usually included in the overall economic consideration of thermal oxidation as a technique.

Economics

This technique requires high capital investment, but the major consideration when assessing the suitability of thermal oxidation is the operating cost in terms of the fuel requirements. The use of recuperative or regenerative heat recovery systems can improve the efficiency of the technique and reduce the operating costs. Retrofitting is possible for all types of smoking kilns, at varying costs. Smoking kilns are available with integrated thermal oxidation equipment.

Driving force for implementation

To prevent complaints about odours and to meet legal requirements.

Example plants

See Table 2.8.

Reference literature

[16, Willey et al. 2001], [20, Nordic Council of Ministers 2001], [35, Germany 2002], [168, COM 2016], [193, TWG 2015]

2.3.7.3.7 Catalytic oxidation

Description

Combustible compounds in a process off-gas or waste gas stream are oxidised with air or oxygen in a catalyst bed. The catalyst enables oxidation at lower temperatures and in smaller equipment compared to a thermal oxidiser.

Technical description

Catalytic oxidation is a process similar to thermal oxidation with the fundamental difference being that the oxidation reaction takes place in the presence of a catalyst rather than in free air. The main advantage of catalytic oxidation is that significantly lower operating temperatures are required, e.g. 250 °C to 700 °C. Catalytic oxidisers do not operate effectively until they reach the combustion temperatures of the pollutants they are used to destroy, so they need to be started up before they are actually required.

As with adsorption, the reactants for the heterogeneous gas reaction are first transported to the inner surfaces of the generally porous catalysts. As there is a general lack of adequate substance data, such as the reaction speed constant and the diffusion coefficient, reactors are usually designed on the basis of empirical data.

The main components of a catalytic combustion system are auxiliary firing equipment, a heat exchanger and a reactor with a catalyst. A typical layout of a catalytic oxidiser is shown in Figure 2.51.

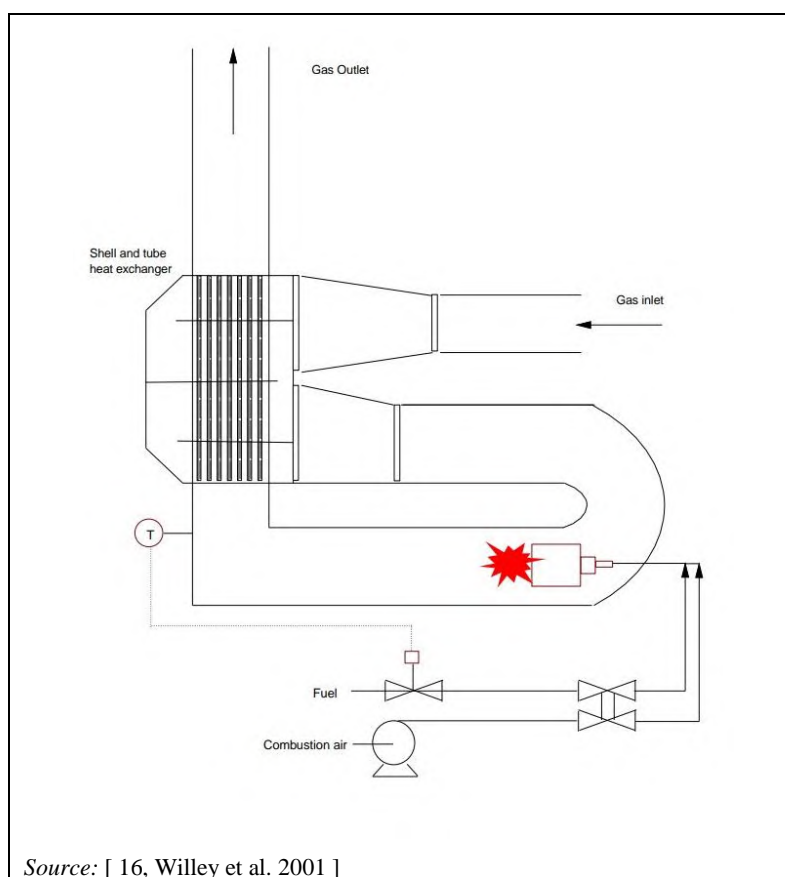

Figure 2.51: Catalytic oxidiser incineration layout

The airstream enters the unit and is preheated in a conventional shell and tube heat exchanger. The preheated inlet stream is then further heated via a burner to the desired oxidation temperature, before passing onto the catalyst. The contaminants present in the odorous airstream, together with oxygen, diffuse onto the surface of the catalyst. Oxidation takes place and the products of oxidation are desorbed back into the gas stream. These transfer processes require a finite time within the catalyst, with the rate of reaction being strongly influenced by the operating temperature. The treated gas stream then passes through the heat exchanger, warming the incoming odorous airstream.

The most important aspect of a catalyst bed is the ratio of surface area to volume and hence the area available for the reaction. Active components commonly used include metals of the platinum group and oxides of the metals Co, Cr, Cu, Fe, Mo, Ni, Ti, V, and W. The support materials are usually metals, in the form of plates, woven fabrics or nets, metal oxides, e.g. Al_2O_3 , SiO_2 and MgO , and minerals, e.g. pumice and zeolite, in moulded shapes.

The following design pointers are considered when evaluating the potential of catalytic incineration as a possible abatement solution: space velocity, pressure drop and temperature.

The space velocity is defined as the reciprocal of the residence time of the gas within the catalyst block, with the volumetric airflow expressed at 0 °C. A typical range of space velocities used in industrial applications is between 5 m/s and 13 m/s. This corresponds to a residence time range of 0.03 to 0.1 seconds at typical operating temperatures. Essentially, there is a trade-off between the amount of catalyst incorporated into the design and the operational temperature. The more catalyst and, hence, operation towards a space velocity of 5 m/s, then the lower the operational temperature required to achieve a given performance. If the airflow to be treated is large, then there is scope to incorporate an additional catalyst to reduce fuel costs by heating to a lower operational temperature. However, an increased catalyst charge will create an increased pressure drop, thereby requiring additional extraction fan power.

The catalyst exhibits a linear relationship between flow rate and pressure drop due to the laminar flow within the catalyst. A typical design would allow for a total system pressure drop of approximately 500 mm. The configuration of the catalyst block plays an important role in minimising the pressure drop and hence the operating costs.

Catalytic oxidation is an exothermic reaction. There are installations where the temperature increases to a sufficient magnitude to enable the catalytic oxidiser to operate in a self-sustaining mode without the addition of fuel after the operating conditions are reached.

Heat recovery might be a part of the process and is sometimes integrated within the design, e.g. by using the treated gases to preheat the incoming gases. In this case heat exchangers are typically designed with an 80 °C heat recovery, which effectively results in a final discharge temperature of between 150 °C and 200 °C for typical oxidation temperatures.

Achieved environmental benefits

Reduced TVOC and odour emissions.

Environmental performance and operational data

Catalytic treatment of waste gases can achieve VOC emission levels of < 1–50 mg/Nm³. Carbon monoxide emission levels of < 10–300 mg/Nm³ have been reported. In contrast, the NO_x emission levels can reach extremely high values, e.g. emission levels of around 1 mg/Nm³ to 3 000 mg/Nm³ have been reported during catalytic treatment. In any case, the VOC, CO and NO_x performances are directly affected by many parameters such as type and quantity of processing product, as well as the characteristics and flow rate of the waste gases to be treated [200, Italy 2016].

Compared to incineration, catalytic incineration requires a lower operating temperature and has no need for special construction materials. The likely odour removal performance of a catalytic incinerator is in the region of greater than 95 %, which is less than the approaching 100 % reported for incineration.

Compounds such as sulphur, halogens, zinc and organic solids tend to coat the catalyst surface. Fortunately, this process is reversible with the catalyst activity re-achievable by the application of a high temperature. Inert particulate material will also result in a gradual decrease in catalyst activity, although the application of a high temperature, approximately 500 °C, will return the catalyst activity.

The honeycomb structure is more effective than other structures in minimising problems of attrition, mechanical stability, excessive pressure drop and chemical stability in oxidising atmospheres.

The effective lifetime of the catalyst is largely dependent upon the nature of the airstream being treated. Lifetimes reported vary considerably over a range of 2 to 10 years, although they are more typically between 3 and 5 years.

Smokehouse waste gases are often treated using catalytic oxidation, at temperatures of between 350 °C and 450 °C. Precious metals (platinum, palladium) or certain metal oxides (copper, chromium) deposited on ceramic surfaces are used as catalysts. They are sensitive to dust, fat aerosols and catalyst poisons such as lead and other metals. The efficiency is reported to be high and heat can be recovered.

Cross-media effects

The incineration process has the potential to generate unwanted by-products of combustion, e.g. high emission levels of NO_x and CO₂. Essentially, the higher the reaction temperature then the greater the potential for the generation of increased emission levels of NO_x. It is usually beneficial to opt for a low-NO_x burner. There is a relatively low formation of NO_x at operating temperatures and emission levels of 15 mg/Nm³ can be achieved. However, this value (relating only to fuel combustion) does not take into account the NO_x contribution that might derive from materials used in the process [200, Italy 2016].

Any compounds containing sulphur present in the odorous gas stream will generate SO₂ emissions and the potential for minimising this should be considered. The presence of chlorides in the odorous airstream may need to be reviewed due to the potential formation of acidic gases such as HCl. As well as leading to potential emissions, there could be potential corrosion problems within the incinerator. When halogenated VOCs are present, special conditions to suppress the formation of dioxins may be required, though normally there is negligible dioxin formation during the combustion of waste gas streams [168, COM 2016].

Technical considerations relevant to applicability

The presence of dust in the gas stream tends to accumulate at the front edge of the catalyst, resulting in a gradual increase in the catalyst pressure drop. Whilst the literature would suggest that dust concentrations of up to 115 mg/Nm³ are possible, in practice a maximum concentration of 50 mg/Nm³ is mentioned as a guideline.

Catalytic abatement systems occupy less space than thermal ones.

Economics

Lower fuel costs compared to incineration.

Driving force for implementation

Compliance with legislation on odour control.

Example plants

Used in the coffee sector and to treat smokehouse waste gases. See also Table 2.8.

Reference literature

[16, Willey et al. 2001], [20, Nordic Council of Ministers 2001], [35, Germany 2002], [168, COM 2016], [192, COM 2006], [193, TWG 2015], [200, Italy 2016]

2.3.7.3.8 Non-thermal plasma treatment

Description

Abatement technique based on creating a plasma (i.e. an ionised gas consisting of positive ions and free electrons in proportions resulting in more or less no overall electric charge) in the waste gas by using a strong electrical field. The plasma oxidises organic and inorganic compounds.

Technical description

Non-thermal plasma treatment is an odour abatement technique based on creating a highly reactive treatment zone in the waste gases in which the odorous molecules are broken down. The way in which this reactive zone is created may vary.

The general principles used in non-thermal plasma technology are to accelerate the natural destruction of the chemical composition in the process emission. Hence, there are no by-products created from the process.

Plasma is a gas state in which the gas component molecules are separated into a collection of ions, electrons, charge-neutral gas molecules and other species in varying degrees of excitation. Depending on the amount of energy added, the resulting plasma could be characterised as thermal or non-thermal.

In thermal plasma, the plasma constituents are in a thermal equilibrium. The ions and electrons are, on average, at the same temperature corresponding to approximately 1–2 eV (where 1 eV corresponds to a temperature of 11 327 °C). The electric arc in an electric arc furnace is an example of thermal plasma.

In non-thermal plasma, the electron energy levels, or speeds, are considerably higher than those of the bulk gas molecules (i.e. they are not in a thermodynamic equilibrium). Because energy is added to the electrons only, these can attain energies from 1 to 10 eV, while the background gas remains at the equivalent of ambient temperature. The high electron energies generate plasma in which free electrons, ions and radicals coexist. Due to changes in waste gas conductivity, non-thermal plasma technology is less effective at waste gas temperatures exceeding 80 °C.

Non-thermal plasma can be used to treat odorous waste gases at ambient pressure and temperature. The radicals in the plasma react with the pollutants, which are broken down and oxidised to produce less odorous components. The most active radicals in this process are nitrogen-, oxygen-, and hydroxyl-based. These species originate from nitrogen, oxygen and water in the waste gas. Industrial treatment systems are based on electrical discharge, where high voltages (up to 40 kV) are used to create plasma within the waste gases. Figure 2.52 shows a proprietary design of an industrial non-thermal plasma treatment system.

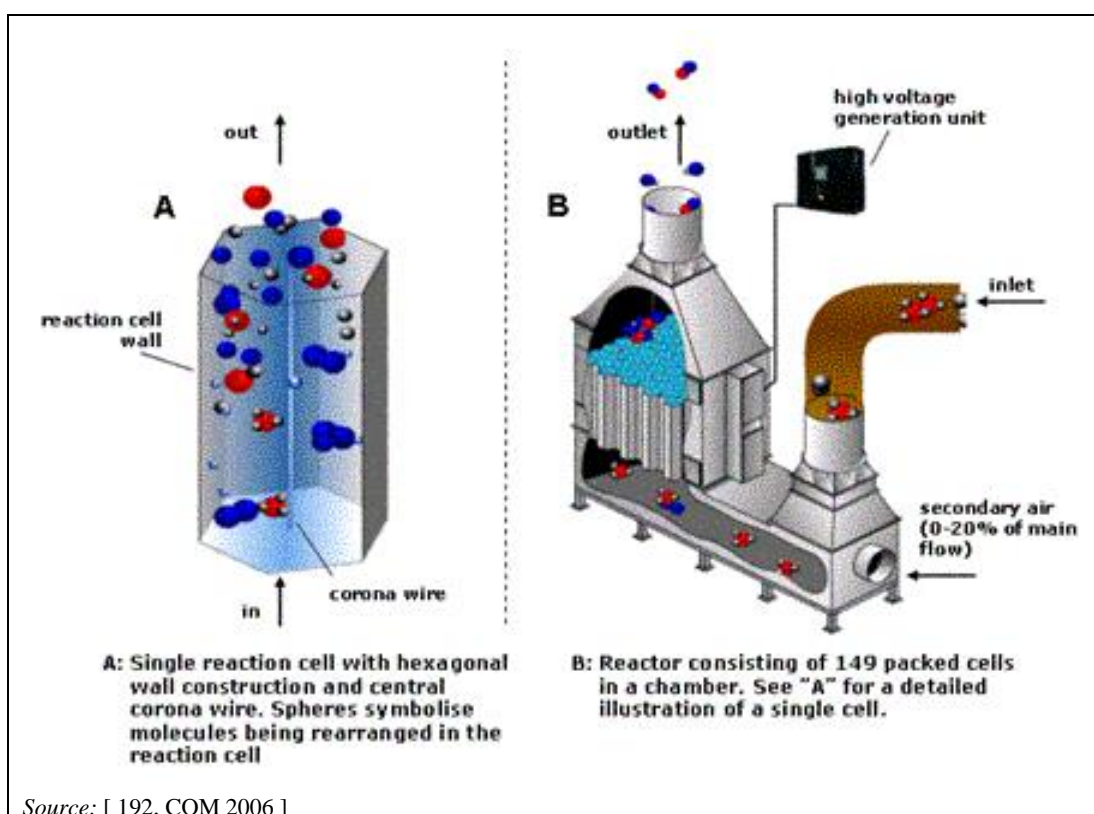

Figure 2.52: Industrial non-thermal plasma treatment equipment

Equipment for the non-thermal plasma treatment of odours is of modular design with a light and compact construction. One module treats air volumes in the range of 20 000–25 000 Nm³/h. When larger treatment capacities are required, multiple modules can be installed in parallel. The technique requires no process additives and no consumables for the operation, apart from power. It has a low pressure drop, in the range of 30–180 Pa. It can be installed both on the suction side and the pressure side of the main air extraction fan.

Achieved environmental benefits

Reduced TVOC and odour emissions to air.

Environmental performance and operational data

The technique has been proven to reduce odour emissions by 75–96 %, depending on the design, process conditions and odour characteristics.

The power consumption is reported to be 6–12 kW (1.67–3.33 J/h) for a treated volume of 20 000–25 000 Nm³/h (one module). This includes the energy used by the high-voltage generation unit, but excludes increased energy consumption in the main exhaust fan to overcome the pressure drop (30–180 Pa) of the unit and the energy required for any extra air. Extra air may be needed to maintain a sufficient level of radicals in the gas mixture and possibly for cooling the gases to the temperature where the technique is most efficient, i.e. between 15 °C and 80 °C, or to condense water upstream of the treatment unit. The need for additional air can be up to 20 % of the treated volume and is normally supplied by a dedicated fan.

Table 2.69 shows some data reported from various industries in the FDM sector.

Table 2.69: Volumes treated at some installations that apply non-thermal plasma treatment to reduce odour emissions

Country applied	Industry	Treated source	Treated volume (Nm ³ /h)	Installed (year)
Denmark	Fishmeal	Extruders, dryers, coolers	22 000	2000
Denmark	Dry peas and pea products	Extruders, dryers, coolers, hammer mills	25 000	2001
Denmark	Proteins	Dryers	25 000	2002
Denmark	Oil extraction	Dryers	25 000	2002
Denmark	Animal feed	Dryers, coolers	50 000	2002
Germany	Fish-feed sterilisation		6 000	2003
Greece	Fishmeal	Extruders, dryers, coolers	44 000	2000
Greece	Fish-feed	Dryers and coolers	22 000	2004
Norway	Fishmeal	Extruders, dryers, coolers	1 750 000	1998
Norway	Fishmeal	Extruders, dryers, coolers	115 000	1998
Norway	Fishmeal	Extruders, dryers, coolers, hammer mills	40 000	2000
Japan	Fish-feed	Dryers and coolers	20 000	2004
United States	Fishmeal and pet food	Extruders, dryers, coolers	25 000	2002

Source: [192, COM 2006]

Like many end-of-pipe techniques, the technique performs better when treating a highly concentrated flow than a flow with a low concentration of pollutants. Field tests on specific odour compositions determine the design of the installation and the guarantees that are given. If the full-scale installation has to treat significantly different odour molecules, e.g. due to changes in raw materials or concentrations, this may influence the performance. This is normally solved by introducing different system settings for different products/recipes, controlled automatically from the plant's central control system.

The technique is reported to operate well with up to 100 % humidity. One installation reports that when the waste gas was oversaturated with water (> 100 % humidity) this caused rain inside the reactor. The water droplets in the reaction chamber led to frequent spark-over in the reaction zone, resulting in a reduced power input to the airstream and consequently a reduced cleaning efficiency. In situations like this, the power setting of the system can be reduced to limit the amount of spark-over to an acceptable level, i.e. ≤ 20 sparks/min. In the reported case, the achieved cleaning efficiency was still high enough to meet the authority requirements for total allowed odour emission, so the customer accepted the system performance without modification. This type of problem is normally solved by admixing up to 20 % cold air, to stimulate condensation, and installing a mist filter prior to the plasma treatment unit. This has been carried out in several installations.

Above 80 °C, the performance of the technique drops significantly, due to the electrochemical characteristics of the waste gas, so a maximum input temperature of 70 °C is specified. Airstreams at higher temperatures can be cooled by adding air at ambient temperatures.

The equipment is engineered to treat a specified volume of air and built as modular units, normally to handle 20 000 m³/h/module. For higher volumes, several modules can be installed in parallel. However, if the actual flow is significantly different from the design parameters, there might be an effect on the performance.

In addition to odour destruction, the plasma reactor also acts like an electrostatic precipitator. For a dust-laden airstream, there will, therefore, be a build-up of dust over time in the reaction chamber and on the corona wire. The speed of this build-up will depend on the dust load and the dust characteristics. Experience has shown that the plasma technique works well with dust loads of < 25 mg/Nm³. In such circumstances, the reactor can be in continuous operation for up to several months, after which cleaning is normally required. For this reason, many of the industrial applications are equipped with a wet cleaning system that operates (semi-) automatically during production stops and flushes the collected dust to a WWTP. At very high dust loads, there is a risk of clogging the equipment and frequent cleaning is required. In addition, high dust concentrations in the waste gas will increase the frequency of spark-over and may reduce the odour cleaning efficiency. Normally, such high concentrations will only occur during failure of upstream dust abatement equipment.

Cross-media effects

Energy is required to create the plasma and to transfer air to the gas mixture for the process and for cooling and water condensation. Ozone is generated. Waste water, contaminated with dust for example, is produced.

Ozone is generated in the plasma reactor and emitted to the air. In industrial applications, ozone emission levels are kept well below 1 ppm by volume, although this is generally not monitored after commissioning. NO_x and SO_x are not generated in detectable quantities, due to inorganic compounds like NH₃ and H₂S, not being effectively destroyed.

Technical considerations relevant to applicability

Non-thermal plasma treatment can be installed as an end-of-pipe solution to odorous waste gases in the FDM industry. This includes the emissions from extruders, dryers, coolers and hammer mills. The technique is applied to various types of waste gas, including those containing dust, although upstream dust abatement may be required. The most odorous waste gases contain a mixture of organic and inorganic components. The plasma process has a high performance for organic components, but is less efficient at removing some inorganic components, e.g. NH₃ and H₂S. This is due to the fact that the energy densities achievable have insufficient power to break down these compounds. The technique has to be protected from significant amounts of water condensing on the equipment.

Economics

According to the technology supplier, one module (treating between 20 000 Nm³/h and 25 000 Nm³/h) will cost around EUR 117 000 (March 2004). This includes the necessary equipment, electromechanical service and commissioning from the supplier, but excludes mechanical installation. Annual maintenance costs are approximately 3 % to 5 % of the investment costs. Consumables include power and minor quantities of rinsing water.

Driving force for implementation

To prevent complaints about odours and to meet legal requirements.

Example plants

In the FDM industry, the technique has reportedly been applied on an industrial scale in several fishmeal factories and in the production of pea products, pet food, proteins, and oil extraction. It has also been applied in at least one waste sorting installation in Denmark, a manure processing installation in Norway and a pharmaceuticals installation in Norway. It has been applied for its electrostatic cleaning effect in at least one silicon carbide installation in Norway.

Reference literature

[79, Leendertse A. 2003], [103, Leendertse A. and Haaland A.T. 2003], [192, COM 2006]

2.3.7.3.9 Extension of the height of the discharge stack**Description**

Height extension of the discharge stack.

Technical description

The effect of buildings or structures within the vicinity of the stack discharge can often cause poor dispersion and, in some cases, the phenomenon known as plume grounding, where the exhaust is pulled downwards under the influence of nearby structures. Air dispersion models can take account of the potential influence of these structures.

Achieved environmental benefits

Reduced perception of odour problems in the vicinity of the odour source.

Environmental performance and operational data

This process is typically carried out using a correlation taking into account the height, width and length of the building. For example, in the breeze computer model as validated by the Environmental Protection Agency in the United States, a correlation is used that incorporates the height and maximum projected width of nearby buildings. The maximum projected width is defined as the diagonal distance (L) between extreme corners of the building at the maximum building elevation. The procedure is then to draw a radius of 5 x L from the building/structure. If the stack discharge falls within 5 x L of the nearby building/structure, then the presence of that building will likely have a negative impact on the dispersion from the nearby stack. Similarly, if the stack discharge is outside of the 5 x L radius then the building/structure will have no effect on the dispersion.

The procedure subsequently allows the user to determine the required stack height such that the stack is at a sufficient elevation not to be influenced by the building/structure. The procedure involves comparing the diagonal distance (L) with the building/structure height and the lesser of these two measurements is used in the following equation to determine the stack height required so as not to be influenced by the building/structure.

$$h_e = h_b = 1.5 \times L$$

Where:

h_e = required stack height

h_b = height of the building/structure

L = diagonal distance

This procedure can be used as a simple check to ascertain whether an existing stack discharge would be influenced by a nearby building/structure. The analysis indicates whether or not extensions to the stack height would be a viable option. In this respect, reference to any planning restrictions, in terms of maximum elevations, would need to be considered in addition to the need for increased supporting structures for example.

Cross-media effects

Reduced visual amenity due to the presence of the chimney(s). The production and emission of the odorous substance(s) has not been prevented or abated.

Technical considerations relevant to applicability

Applicable in all FDM installations with odorous emissions which are not considered to be harmful to the environment, only offensive.

Economics

Low-cost technique.

Driving force for implementation

No information provided.

Example plants

No information provided.

Reference literature

[16, Willey et al. 2001]

2.3.7.3.10 Increase of the stack discharge velocity

Description

Increase of stack discharge velocity.

Technical description

The magnitude of the discharge velocity applied to a final emission to the air can have a significant effect on the resultant ground-level impact of an odorous emission. An increased discharge velocity will result in an increased momentum or buoyancy of the emission. This implies that the discharge will attain an increased elevation thereby allowing more potential for dispersion in the air and hence lower ground-level concentrations.

Achieved environmental benefits

Reduced odour emissions.

Environmental performance and operational data

A typical design range for final discharge velocities from stacks is between 10 m/s and 20 m/s, with an industry standard of 15 m/s. Design velocities of less than 10 m/s are likely to suffer from poor dispersion, whilst velocities above 20 m/s can prove expensive in terms of extraction fan power and operating costs. Furthermore, discharge velocities greater than 20 m/s can result in significant noise as the discharge generates a whistling phenomenon.

There may also be restrictions on the design velocity that can be applied to certain installations. In guidance documents, it is common for the discharge from a wet separation plant such as a water scrubber to be limited to no greater than 9 m/s. This restriction is designed to prevent the carryover of a significant quantity of water droplets resulting in a fountain effect.

The stack discharge velocity can be reduced significantly if there are physical restrictions in the discharge flowpath. Restrictions reduce the momentum of the plume during discharge. Many discharge stacks have a cone fixed over the outlet, designed to prevent rainfall entering the process via the discharge stack. The discharging process air is thus forced outwards through 90 ° rather than upwards, resulting in a considerable loss of available momentum. If the use of rainfall protectors is avoided, the stack design then needs to take account of rainfall and its collection.

Cross-media effects

Energy consumption.

Technical considerations relevant to applicability

Applicable in all FDM installations.

Economics

Low-cost technique.

Driving force for implementation

No information provided.

Example plants

No information provided.

Reference literature

[16, Willey et al. 2001]

2.3.7.3.11 Odour management plan**Description**

An odour management plan is part of the environmental management system (EMS) approach as described in Section 2.3.1.1.

Technical description

As odour arises from different operational areas, it is good practice for the odour management plan to include all potential odour sources and to seek to control them in an integrated way.

An odour management plan includes the following elements:

- a protocol containing appropriate actions and timelines;
- a protocol for conducting odour monitoring;
- a protocol for response to identified odour incidents, e.g. complaints;
- an odour prevention and elimination programme designed to identify the source(s), to monitor odour emissions (see Section 4.18.4), to characterise the contributions of the source(s) and to implement elimination and/or reduction measures;
- a review of historical odour incidents and remedies and the dissemination of odour incident knowledge.

In more detail, an odour management plan could encompass the following elements:

- containment and extraction of primary emission sources for treatment via odour removal system(s);
- design factors for abatement system(s) to include assessment of the inlet gas stream for the following parameters:
 - contaminants present (individual contaminants, concentration and variability);
 - flammability (upper and lower explosive limits);
 - flow rate (air flow capacities, continuous/intermittent flow);
 - temperature of gas stream (average and maximum);
 - gas pressure;
 - relative humidity content.
- dispersion of the treated gas flow;
- contingency measures during abnormal events.

Achieved environmental benefits

The minimisation of odorous emissions is the achieved environmental benefit. Many of the management techniques to reduce odour will also simultaneously reduce other emissions to air.

Environmental performance and operational data

No information provided.

Cross-media effects

There are no cross-media effects associated with the implementation of this technique.

Technical considerations relevant to applicability

The technique is applicable to new and existing installations provided that an odour nuisance at sensitive receptors is expected and/or has been substantiated.

Economics

No information provided.

Driving force for implementation

Management systems are likely to be less of a cost burden, or may even improve financial returns for producers, and often have lower capital costs and require less resources (energy, water, chemicals etc.) than end-of-pipe treatments.

Example plants

No information provided.

Reference literature

[91, Giner Santonja et al. 2017]

2.3.7.4 Techniques to reduce NO_x emissions

2.3.7.4.1 Low-NO_x burners

For more information consult the LCP BREF [145, COM 2017].

Description

The technique is based on the principles of reducing peak flame temperatures; boiler burners are designed to delay but improve the combustion and increase the length of the flames, allowing the heat radiated during combustion to reduce peak temperatures. The air/fuel mixing reduces the availability of oxygen and reduces the peak flame temperature, thus retarding the conversion of fuel-bound nitrogen to NO_x and the formation of thermal NO_x, while maintaining a high combustion efficiency. This may be associated with a modified design of the furnace combustion chamber.

Technical description

Low-NO_x burners have reached a mature stage of development, but further improvements are ongoing and a considerable amount of research work is still devoted to the enhancement of existing low-NO_x burner systems. Since design details of low-NO_x burners differ significantly from manufacturer to manufacturer, only the general principle is referred to here.

In a classic combustion installation, the combined fuel and air/oxygen mix is entirely injected at the same place. The resulting flame is then composed of a hot and oxidising primary zone located at the flame root and a colder secondary zone located at the flame tip. The primary zone generates most of the NO, which increases exponentially with temperature, whereas the contribution of the secondary zone is more modest.

Low-NO_x burners modify the means of introducing air and fuel to delay the mixing, reduce the availability of oxygen, and reduce the peak flame temperature.

According to the different principles to reduce the formation of NO_x, low-NO_x burners have been developed as air-staged burners, hot gas recirculation burners and fuel-staged burners.

Achieved environmental benefits

Reduced NO_x emissions to air.

Environmental performance and operational data

No information provided.

Cross-media effects

No information provided.

Technical considerations relevant to applicability

No information provided.

Economics

For new installations, the additional investment for a low-NO_x burner compared to a classic burner can be considered negligible. For retrofits, possible modifications to the installation have to be taken into account, which are very often plant-specific and thus not quantifiable in general terms.

Driving force for implementation

Reduction of NO_x emissions.

Example plants

No information provided.

Reference literature

[145, COM 2017]

2.3.8 Techniques to reduce noise

2.3.8.1 Low-noise equipment

Description

This includes low-noise compressors, pumps and fans.

Technical description

The principal cause of fan noise is turbulence and local slowing of flow rates due to vortex shedding. Vortex shedding is the periodic detachment of vortices from an object in a fluid flow, causing a varying force to be experienced by the object.

The most efficient and the quietest fans are usually the ones with the lowest blade tip speed, i.e. those with a large diameter and a low speed. For a given duty, a backward-curved or backward-inclined fan working at peak efficiency is quieter than a radial tipped fan.

Additional noise reduction measures include using flexible connections between fans and ducts to minimise the transmission of vibration and mounting fans on vibration isolators to prevent transmission of vibration to supporting structures. The higher frequencies, from fans with many blades, tend to dissipate over shorter distances than the lower frequencies emitted from fans with fewer blades. Figure 2.53 shows the effect of modifying a roof-mounted fan to produce a higher-frequency noise.

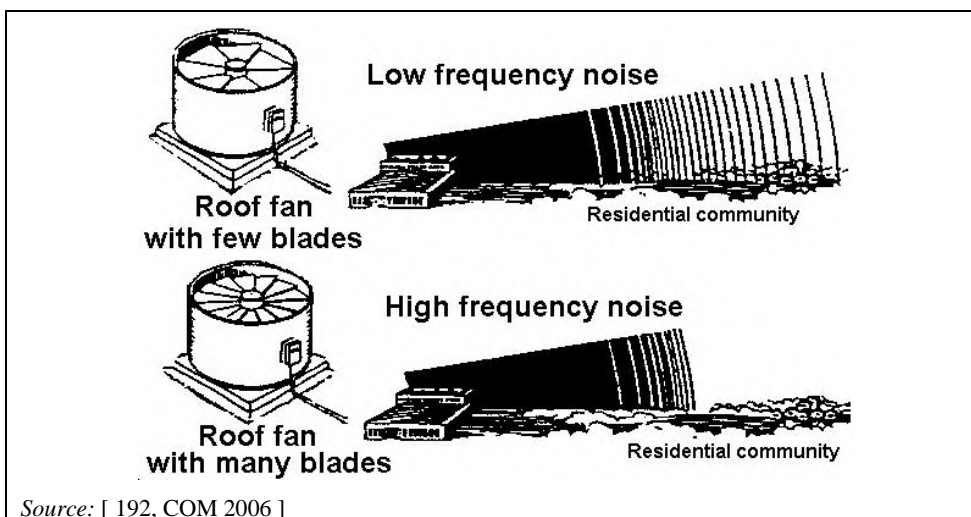

Figure 2.53: The effect of the number of fan blades on the distance of noise transmission

Achieved environmental benefits

Reduced noise emissions.

Environmental performance and operational data

In an example spray dryer, a fixed speed 2 500 rpm fan delivering approximately 45 000 m³/h was replaced with two smaller fans running at 1 500 rpm and delivering the same total air volume. Control of the new fans was obtained by reducing their speed, rather than using a damper. The net reduction in noise was approximately 8 dB(A).

Table 2.70 shows the noise reduction that can be expected from reducing the fan speed. Every 3 dB(A) reduction is equivalent to halving the noise level.

Table 2.70: A guide to the noise reduction expected from reducing fan speeds

Fan speed reduction	Noise reduction
10 %	2 dB(A)
20 %	5 dB(A)
30 %	8 dB(A)
40 %	11 dB(A)
50 %	15 dB(A)

Source: [192, COM 2006]

Cross-media effects

No information provided.

Technical considerations relevant to applicability

Applicable where fans are used, e.g. for air conditioning, ventilation and refrigeration.

Economics

The cheapest fans are usually those with the smallest diameter, but these tend to be the noisiest. The cost of a fan is, however, usually a relatively small proportion of any overall project and the cost is, therefore, not the governing factor.

Driving force for implementation

Reduced complaints about noise emissions from outside the installation.

Example plants

No information provided.

Reference literature

[35, Germany 2002], [147, Lewis D. N. 2003], [192, COM 2006]

2.3.8.2 Design of pipework to minimise noise emissions**Description**

Pipework design to minimise noise emissions.

Technical description

Pipes can be enclosed within walls or laid in special ducts to reduce noise emission levels. Optimum results are achieved by either lining or filling cavities with sound-absorbing material. Sound insulation can be improved by:

- selecting pipe material with sound-insulating properties, e.g. cast iron instead of plastic;
- increasing the thickness of the pipe wall;
- insulating the pipe.

The material and the geometry of the pipe wall determine the propagation of the airborne noise. Damping the vibrations in the pipe wall that give rise to airborne noise causes a reduction in sound energy by absorption, as the sound spreads through the fluid. This damping effect is not important at low frequencies, but increases as the frequency rises. The damping effect decreases as the pipe diameter increases. Irregularities in the surface of the pipe also increase the damping effect. If pipes have a sound-absorbing inner lining, then at higher flow speeds the damping is considerably reduced for sound propagation in the direction of flow and increased for sound propagation against the direction of flow.

When dimensioning pipes, it is important to ensure that the principal excitation frequency of the sound level entering the pipe is sufficiently far from the natural frequencies and pass frequencies of the pipes. All natural frequencies are influenced by the way the pipes are mounted and the route taken by the pipe, e.g. the number and position of bends and any internal baffles.

Achieved environmental benefits

Reduced noise emissions.

Environmental performance and operational data

Pipes are used to transport gases, vapours, liquids and solids with a carrier fluid. The noise emissions arising from pipes include noise transmitted by the fluids and solids, as well as airborne noise transmission. Virtually no noise results from laminar flows, but increasing turbulence leads to increased noise emission levels within pipes.

Cavitation causes intensive noise. Cavitation occurs when the static pressure is locally equal to or less than the vapour pressure, and occurs where the direction of flow is changed for example.

When solids are transported with the aid of carrier fluids, additional noise results from contact of the solid particles with each other and with the walls of the pipe, particularly when hard particles are transported using a gaseous fluid. The sound pressure level depends on the flow rate, the material of the pipe, and the type of solid. Sound pressure levels may reach between 85 dB(A) and 100 dB(A) at a distance of 1 metre from straight pipe elements. This can be expected to increase by a further 10–15 dB(A) near bends.

Cross-media effects

No information provided.

Technical considerations relevant to applicability

Applicable where pipes are used to transport gases, vapours, liquids and solids with a carrier fluid.

Economics

No information provided.

Driving force for implementation

Prevention of occupational noise-induced hearing loss and reduced complaints about noise emissions from outside the installation.

Example plants

No information provided.

Reference literature

[35, Germany 2002]

2.3.8.3 Sound insulation of equipment

Description

An insulating enclosure usually consists of a metal jacket lined with absorbing material which wholly or partially encloses the sound source.

Technical description

Sound-insulating enclosures can be built around sources of noise pollution. An insulating enclosure usually consists of a metal jacket lined with absorbing material which wholly or partially encloses the sound source. The noise level reduction that can be achieved depends on the insulation of airborne sound by the walls and the absorption capacity of the internal lining. The size, shape and materials of the screen can be determined by acoustic design calculations to ensure that particular design targets, i.e. noise emission levels, are met. Connecting fans and the ducts or housings using elastic linkages and placing noisy equipment on noise-absorbing bases can also reduce noise emission levels.

Achieved environmental benefits

Reduced noise emissions.

Environmental performance and operational data

Some examples of uses of sound insulation materials in the FDM sector include:

- for glass bottling lines, enclosing glass bottle conveyors and cap feeder hoppers;
- lining insides of hoppers with impact-deadening material and lining outsides of hoppers and guard panels;
- at packing machines, lining cover panels and enclosing bagging lines;
- in the meat sector, fitting noise-dampening hoods over bowl choppers;
- in the dairy sector, enclosing homogenisers (e.g. in sound-insulated rooms which require infrequent access);
- enclosing spray dryers (e.g. in sound-insulated rooms which require infrequent access);
- in milling operations, enclosing hammer mills, roller mills and mixers;
- in freezers and cold stores, enclosing the refrigeration machinery allowing for the ventilation of motors and fans;
- enclosing vapour compressors.

For some applications it may be necessary to allow the entry or release of air from an acoustic enclosure. This reduces the noise reduction potential, but the effect of this may be reduced by designing bends in the airways to abate the noise emissions. For example, fans can be enclosed in sound-insulating enclosures designed to minimise the build-up of reflected noise inside the enclosure and adequate ventilation for cooling of the fan needs to be provided.

For ductwork, instead of fitting silencers, it is often possible to achieve a 10–20 dB(A) reduction in airborne noise from a duct or opening by lining the last bend in the ductwork with a noise-absorbing material or by constructing a simple absorbent lined right-angled bend to fit on

the opening. It is reported that either side of the bend should be lined along a length equivalent to twice the duct diameter.

Cross-media effects

No information provided.

Technical considerations relevant to applicability

This technique is used for a variety of equipment used in the FDM sector, e.g. fans, compressors, pumps and blowers.

Economics

No information provided.

Driving force for implementation

Prevention of occupational noise-induced hearing loss and reduced complaints about noise emissions from outside the installation.

Example plants

Insulation of noisy equipment is widely applied in the FDM sector, e.g. at glass bottling lines; at hoppers where there is noisy product impact; during packing, e.g. while wrapping, cutting and bagging; at bowl choppers used in the meat sector; in grain milling, e.g. in the manufacture of flour and animal feed; and in freezing and cold storage.

Reference literature

[110, CIAA 2003], [147, Lewis D. N. 2003]

2.3.8.4 Appropriate location of equipment and buildings

Description

Noise levels can be reduced by increasing the distance between the emitter and the receiver, by using buildings as noise screens and by relocating buildings' exits or entrances.

Technical description

Noise levels can be reduced by increasing the distance between the emitter and the receiver, by using buildings as noise screens and by relocating buildings' exits or entrances. Moreover, some equipment emits different noise levels in different directions. For example, any equipment which has a fan inlet or outlet on one side will have its maximum noise level on that side. Positioning the equipment so that the noisiest side faces away from a sensitive location could, therefore, reduce the immission levels there. This cannot be guaranteed to always be effective because the direction in which sound is carried varies with weather conditions.

Achieved environmental benefits

Reduced noise emission levels at receptor sites away from the noisy side of the equipment.

Environmental performance and operational data

No information provided.

Cross-media effects

The emission of noise is not prevented or reduced at all and therefore the risk of occupational noise-induced hearing loss or complaints may remain.

Cross-media effects

No information provided.

Technical considerations relevant to applicability

For existing plants, the relocation of equipment and buildings' exits or entrances may not be applicable due to lack of space and/or excessive costs.

Economics

No information provided.

Driving force for implementation

Reduced noise levels at sensitive receptor sites.

Example plants

No information provided.

Reference literature

[35, Germany 2002], [110, CIAA 2003], [147, Lewis D. N. 2003]

2.3.8.5 Sound insulation of buildings

Description

Sound insulation of buildings.

Technical description

The acoustic output of machines and the acoustic properties of the rooms determine the sound pressure levels inside a building. These internal sound pressure levels and the sound insulation provided by the external shell, i.e. walls, roofs, windows, doors and openings, result in the airborne sound power, i.e. the emission level. This can be a particular problem when equipment is inside steel frame buildings with relatively lightweight profiled cladding. The acoustic power of a source is related to its surface area. Large building facades can, therefore, radiate significant acoustic power.

Buildings can be insulated against airborne noise. It is much easier to insulate against high-frequency noise than low-frequency noise. Either single-shell or double-shell insulation can be provided. The sound insulation of components of a more or less homogeneous structure depends largely on their weight per unit area. The nature of the material is also important.

Double-shell buildings consist of two dense shells separated by an air gap or a resilient insulating layer. Under certain conditions, the sound insulation provided by such elements is greater than that of single-shell elements of the same weight. The most important requirement for better sound insulation is that the air gap between the shells is sufficiently large or that any insulating layer between the shells is sufficiently resilient and open textured. The insulating effect of the cavity is achieved by filling it with sound-absorbing materials, e.g. mineral fibre panels. Rigid connections between the double shells have an adverse effect on sound insulation.

The sound insulation of any wall is only as good as the weakest link. The sound insulation of windows, doors, roofs and louvres has to be considered so that the sound insulation of the composite structure can be calculated. If the sound reduction index of windows and doors matches or approaches that of the wall, then the overall performance will be maintained. If a poor-fitting door and a light window are installed in a block wall, this will significantly reduce the noise reduction possible.

If particular design targets are to be met, the size, shape and materials of the screen should be determined by acoustic design calculations.

Achieved environmental benefits

Reduced noise emissions.

Environmental performance and operational data

No information provided.

Cross-media effects

No information provided.

Technical considerations relevant to applicability

Applicable to all FDM installations, e.g. where fans are used for air conditioning, ventilation and refrigeration.

Economics

No information provided.

Driving force for implementation

Reduced complaints about noise emissions from outside the installation.

Example plants

No information provided.

Reference literature

[35, Germany 2002], [110, CIAA 2003], [147, Lewis D. N. 2003]

2.3.8.6 Noise abatement**Description**

Inserting obstacles between emitters and receivers (e.g. protection walls, embankments and buildings).

Technical description

Shielding buildings from immission sites has the effect of reducing the sound pressure level at those sites. Other buildings in the vicinity may provide the shielding effect, or this can be manufactured by constructing barriers such as walls or embankments. It is reported that these can achieve a shielding effect of more than 5 dB(A) if they at least interrupt the line-of-sight connection. The higher the barrier and the closer it is to the noise source and/or immission site, the greater the shielding effect.

Achieved environmental benefits

Reduced noise emissions.

Environmental performance and operational data

No information provided.

Cross-media effects

The emission of noise is not prevented or reduced at all and therefore the risk of occupational noise-induced hearing loss or complaints may remain.

Technical considerations relevant to applicability

Applicable only to existing plants, as the design of new plants should make this technique unnecessary. For existing plants, the insertion of obstacles may not be applicable due to lack of space.

Economics

No information provided.

Driving force for implementation

Reduced complaints about noise emissions from outside the installation.

Example plants

No information provided.

Reference literature

[35, Germany 2002]

2.3.8.7 Application of a spiral turbulence generator to a chimney to minimise noise emissions

Description

Application of a spiral turbulence generator to a chimney.

Technical description

Air flowing past towers and chimneys creates noise due to eddies and also excites vibrations in the chimney. Applying a spiral turbulence generator interferes with the eddy formation. The gradient of the turbulence generator is not constant. The technique is shown in Figure 2.54.

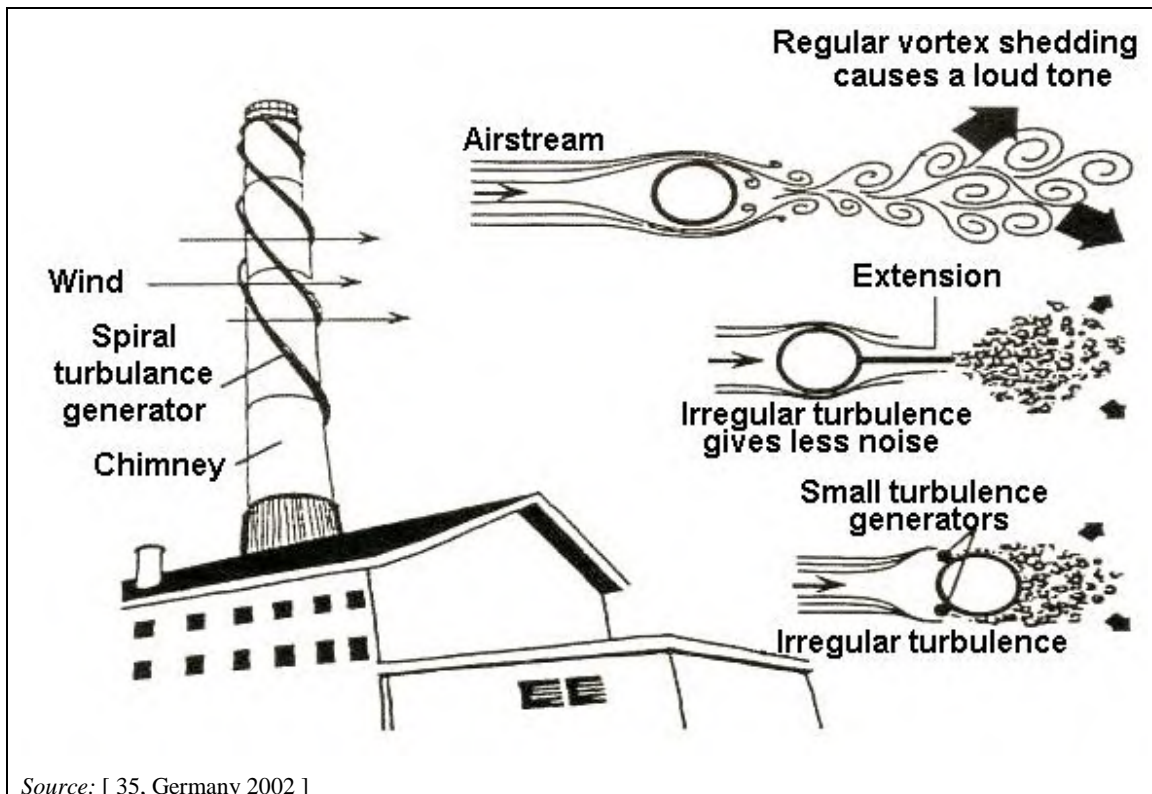

Figure 2.54: Reduction in noise emissions from a chimney

Achieved environmental benefits

Reduced noise emissions.

Environmental performance and operational data

No information provided.

Cross-media effects

No information provided.

Technical considerations relevant to applicability

Applicable where fans are used, e.g. for air conditioning, ventilation and refrigeration.

Economics

No information provided.

Driving force for implementation

Reduced complaints about noise emissions from outside the installation.

Example plants

No information provided.

Reference literature

[35, Germany 2002]

2.3.8.8 Fitting of silencers to air inlets and exhausts**Description**

Application of silencers to the compressor air inlet or exhaust.

Technical description

Silencers are fitted to the compressor air inlet or exhaust. Silencers can be absorptive or reactive. Absorptive silencers absorb the noise. Reactive silencers contain chambers and baffles and their size and position determine the silencer's sound attenuation characteristics. Reactive silencers may be more effective for compressors, which generate significant emission levels of low-frequency tonal noise.

Achieved environmental benefits

Reduced noise emission levels.

Environmental performance and operational data

It is reported that a well-designed silencer will not increase system back pressure. If the silencer is not well designed, increased attenuation may increase pressure loss and consequently increase energy consumption. Back pressure can be minimised by increasing the size of the silencer and the coupling between the silencer and the compressor. Fitting a straight-through silencer can prevent both back pressure and blocking.

It is reported that multiple exhausts can be attached to a manifold leading to a single, larger diameter pipe. It is reported that the rear silencer from virtually any make of car can be used to achieve a typical reduction of 25 dB(A).

Cross-media effects

If the silencer is not well designed, there may be increased energy consumption, due to back pressure or blockage.

Technical considerations relevant to applicability

Applicable where compressed air is used. The air should be filtered within the compressor area. Filters should be cleaned (cleaning frequency to be set depending on the season) to prevent dirty exchangers.

Economics

Low cost.

Driving force for implementation

Prevention of occupational noise-induced hearing loss and reduced complaints about noise emissions from outside the installation.

Example plants

Widely applied in the FDM sector.

Reference literature

[35, Germany 2002], [110, CIAA 2003], [147, Lewis D. N. 2003], [149, Health and Safety Executive 2000], [203, FEFAC 2015]

2.3.8.9 Management of on-site vehicle movements

Description

The times when vehicles enter and leave the installation and the location and times of on-site vehicle movements are controlled.

Technical description

By controlling the times when vehicles enter and leave the installation and the location and times of on-site vehicle movements, noise emissions off site can be reduced at sensitive times, e.g. at night during the hours when neighbours, in residential areas, normally wish to sleep.

This may be optimised further by the selection of quiet vehicles, and ensuring that they are well maintained, and providing road surfaces with low noise transmission qualities.

Achieved environmental benefits

Reduced noise emissions at night.

Environmental performance and operational data

For some FDM processes which practise 24-hour processing, the importance of receiving materials fresh for rapid processing may limit the possibilities to restrict deliveries to daytime. This restriction may apply, for example, to fruit and vegetable processing when harvesting and processing of tomatoes and peas for example is undertaken during 24 hours/day, to ensure ripeness and taste. It may be difficult to limit the arrival and departure times of shift workers to avoid times when noise may cause a nuisance to residential neighbours.

Noise emission levels were measured in the neighbourhood of an example large brewery operating for a full 24 hours a day on working days. Noise emission levels attributed to the brewery were measured at identified nearest immission detection sites. In addition, calculations were made of the noise emission levels at the nearest immission detection sites caused by traffic to and from the brewery, such as incoming raw materials, e.g. malt and outgoing products; by-products and waste, e.g. bottled and canned beer; yeast and brewery residues; and within the installation, e.g. forklift trucks and cars. Traffic to and from the brewery is limited to daytime hours.

Six parcels of land were considered as immission detection sites. With the exception of one site which contained storage and workshop buildings, the parcels of land were not built on.

The measurements of the immissions attributed to the brewery at the nearest immission detection sites are shown in Table 2.71. The noise sources used were the fans and compressors and brief blow-off noises from valves.

Table 2.71: Noise measurements (mean of three independent measurements) from a German brewery

Measuring site*	L_{AFm} (dB(A))	L_{AF95} (dB(A))	Noise source
1 (distance of 100 m)	43.3	42.0	Fans of waste water system
2 (distance of 110 m)	48.0	46.5	Fans of CIP system, roof fans
3 (distance of 75 m)	49.7	48.0	Fans of CIP system, roof fans
4 (distance of 120 m)	48.6	46.0	Fans of CIP system, compressor unit
5 (distance of 110 m)	45.8	44.5	Compressor unit
6 (distance of 110 m)	46.9	45.5	Compressor unit
*The measurement period was 1.5–10 minutes. The values are an average from 3 measurements. L_{AFm} = the maximum noise level measured/read on the noise meter, during the time under consideration. L_{AF95} = the noise level measured in dB(A), exceeded for 95 % of the time under consideration. Source: [192, COM 2006]			

The measurements in Table 2.72 show the noise emissions calculated for daytime and night operation from internal site traffic and supplier traffic.

Table 2.72: Calculated partial rating levels for materials transport and transhipment processes

Site	Partial rating level – night (dB(A))	Partial rating level – day (dB(A))	Rating level	
			(dB(A))	
			Day	Night
1	43.5	52.9	53.7	46.4
2	41.2	51.0	53.7	49.0
3	30.9	44.3	52.8	49.7
4	24.4	37.3	51.2	48.6
5	31.7	41.7	49.1	46.0
6	35.9	44.9	50.1	47.2
<i>Source:</i> [192, COM 2006]				

When calculating the daytime rating levels, the values in Table 2.72 were raised by a rest period (06.00h–07.00h and 20.00h–22.00h) mark-up of 2.4 dB(A). The measured values at all six sites were well below the local immission guide value during the day and also complied with the immission guide value during the night.

The concentration of vehicle movements during the day can have mixed occupational safety implications. During the day visibility may be better, but there may be more people on the site and, together with the additional concentration of vehicles, the management of vehicle movements and the segregation of vehicles from people is a very high priority.

There may be off-site implications in terms of traffic congestion by limiting the hours of reception and dispatch from any site.

Cross-media effects

Increased noise and vehicle emission levels during the daytime.

Technical considerations relevant to applicability

Applicable in virtually all FDM installations.

Economics

No information provided.

Driving force for implementation

Good relations with neighbours and the elimination of complaints about off-site noise emission levels.

Example plants

At least one brewery in Germany.

Reference literature

[35, Germany 2002], [192, COM 2006]

2.3.8.10 Switching off of the engine and refrigerator unit of a vehicle during loading/unloading and when parked

Description

The running engines and the refrigeration units of vehicles are switched off during loading and unloading and when the vehicle is parked.

Technical description

The running engines and the refrigeration units of vehicles can cause noise nuisance. This can be avoided by switching them off during loading and unloading and when the vehicle is parked. If it is necessary to maintain chilled or frozen storage conditions in a vehicle this can be done by using the power supply from the installation.

Achieved environmental benefits

Reduced noise emissions.

Environmental performance and operational data

No information provided.

Cross-media effects

No information provided.

Technical considerations relevant to applicability

Applicable during loading and unloading of vehicles whether refrigerated or not.

Economics

No information provided.

Driving force for implementation

Reduced noise emissions.

Example plants

No information provided.

Reference literature

[14, VITO et al. 2001]

2.4 Emerging techniques across the FDM sector

This chapter includes novel pollution prevention and control techniques that are reported to be under development and may provide future cost or environmental benefits. If available, the information includes the potential efficiency of the techniques, a preliminary cost estimate, and an indication of the time-scale before the techniques might be commercially available. Established techniques in other sectors that are emerging in practice within the FDM sector are not included.

2.4.1 Use of UV/ozone in absorption for odour abatement

Description

Ozone has been used historically as an oxidant in only a limited number of odour control applications. This is primarily because, although it is extremely reactive in the liquid phase, its reactivity in the gaseous phase is lower. A process was developed during the 1980s that enhanced the activity of ozone by the incorporation of UV light. The process uses a conventional packed bed system and a liquid recycling system. Ozone is bubbled into the sump of the absorber and the ozonated water is passed through a bank of UV lamps. Ozone in the presence of UV light produces hydroxyl radicals which are far more reactive than ozone alone. Dissolved organic compounds in the liquid phase are oxidised to carbon dioxide and water and thus the absorber liquor discharged from the system is relatively clean.

Achieved environmental benefits

Reduced odour emissions.

Technical considerations relevant to applicability

Ozone systems have not been effective when applied to hot and humid airflows, e.g. when applied to a poultry processor scald tank vent.

Reference literature

[16, Willey et al. 2001]

2.4.2 Electrochemical activation

Description

Electrochemical activation for cleaning.

Technical description

This technique refers to cleaning and disinfection of equipment within the food industry. The cleaning and disinfection agents are produced at the site through an electrochemical process from sodium chloride (table salt) solution. On the cathode side OH^- ions are formed, which are used for the cleaning. On the anode side Cl_2 is formed. OH^- ions and Cl_2 can react and form hypochlorous acid (HClO), which acts as a disinfectant. Cleaning and disinfection take place with the use of a cold solution.

Savings on energy consumption, chemicals and possibly water consumption are achieved. The technique has not yet been operating long enough to allow the full documentation of this new BAT candidate. One brewery has indicated that the annual energy consumption may be reduced by approximately 100 000 kWh per production line. The cost of chemicals will certainly be significantly reduced.

Achieved environmental benefits

Reduced energy, chemical and water consumption.

Reference literature

[169, Nordic Council of Ministers 2011]

2.4.3 Waste-activated sludge reduction and generation of carbon source for denitrification

Technical description

OpenCEL uses electrical pulses to disrupt the waste-activated sludge (WAS) cell structure, causing the cells to lyse. OpenCEL focused pulse (FP) technology uses high-frequency micro-pulses of between 20 kV and 60 kV for no more than 0.1 second to cause the cell membrane to swell and rupture. Once ruptured, the WAS is more readily degradable by the active microorganisms. Bench-scale research shows that the semi-soluble COD of WAS increased by more than 26 times after OpenCEL treatment compared with untreated WAS. If the WAS treated with OpenCEL is fed to a digester, it degrades more completely, giving higher volatile solids destruction (therefore less biosolids yield) and generating more digester gas (if anaerobic). If fed to an anoxic zone, the ruptured cells become a source of readily biodegradable carbon for denitrification. The denitrification rate using OpenCEL-treated WAS has been shown to be approximately equal to the rate when using methanol as the carbon source but does not include the dangers of methanol handling.

Other research shows that full FP pretreatment should increase biogas production and biosolids removal by 60 % and 40 %, respectively. Note that WAS is approximately 6–10 % nitrogen and 1–2 % phosphorus (more if biological phosphorus removal is practised).

Achieved environmental benefits

Enhanced nitrogen removal.

Reference literature

[124, EPA 2013]

2.4.4 Integrated fixed-film activated sludge systems with biological phosphorus removal

Technical description

The integrated fixed-film activated sludge (IFAS) hybrid processes include any activated sludge system that has some type of fixed-film media in a suspended growth reactor to increase the amount of biomass available for treatment. The IFAS media can be retrofitted into existing activated sludge systems and lagoons. There are two major types of IFAS: (1) Submerged Mobile Media IFAS and (2) Submerged Fixed Media IFAS. The media material varies but is usually a plastic carrier, sponge carrier, or knitted matrix. Mobile media are retained by screened baffle walls and can be allowed to migrate over the entire basin volume or can be retained in specific zones by multiple baffle walls.

An important feature of the IFAS process is that it provides the capability to decouple the solids retention time (SRT) of the suspended biomass from the SRT of the biomass attached to the IFAS media. This feature is especially useful with processes that must nitrify and perform enhanced biological phosphorus removal (EBPR) because the optimal SRT for EBPR is short (< 5 days) while the optimal SRT for nitrification is generally longer (> 8 days) depending on the waste water temperature.

Research has shown that the majority (> 90 %) of the EBPR capability is associated with the suspended biomass, but most of the nitrifying capability (> 70 %) is associated with the biomass attached to the IFAS media. This segregation of EBPR and nitrifying organisms allows the suspended phase to be controlled to a short SRT without the concern that the nitrifying capability of the system will decline or that nitrifier washout will occur. It also retains the bulk of the nitrifier population in the aerobic zone(s), thereby reducing the nitrifier fraction in the anaerobic and anoxic zones where the nitrifiers are ineffective.

Achieved environmental benefits

Enhanced phosphorus and nitrogen removal.

Reference literature

[124, EPA 2013]

2.4.5 Microbial fuel cell-based treatment system**Technical description**

A microbial fuel cell (MFC) is a device that generates electricity from the bacterial metabolism of organic matter (which is measured as chemical oxygen demand in waste water). During the final stage of bacterial metabolism, electrons are passed along the cell membrane and deposited onto a terminal electron acceptor, usually oxygen. Under anaerobic conditions, bacteria must use an alternative electron acceptor like sulphate, nitrate, or –as is the case with a MFC– an electrode. In a MFC, bacteria are grown under anaerobic conditions and they transfer their electrons externally to an anode.

Electrons flow from the anode to a positively charged cathode through an external circuit; this flow of electrons represents an electrical current. The cathode is exposed to oxygen and protons (H^+) that chemically react with the incoming electrons to form water. MFC research is focused on the design of the fuel cell including the number of chambers and their layout; electrode size (surface area), spacing, materials, and quantity; alternatives to and composition of proton exchange membranes; and affordable cathode catalysts.

Biological research is being done to identify bacterial species that optimise the process and to better understand how they transfer electrons externally. A modified MFC that generates pure hydrogen gas for use with hydrogen fuel cells is also being studied. In this approach, no oxygen is supplied at the cathode. Instead, a low voltage is applied to the circuit to facilitate the chemical formation of hydrogen gas (instead of water). Latest advances in MFC research have achieved substantial increases in MFC power production compared to previous designs. While still an emerging technology that is being studied at the laboratory level, in the future MFCs might be capable of producing enough electricity to operate a waste water treatment plant and perhaps even an excess that could be sold back to the grid.

Reference literature

[124, EPA 2013]

3 ANIMAL FEED

Feed is defined (Regulation (EC) No 178/2002) as ‘any substance or product, including additives, whether processed, partially processed or unprocessed, intended to be used for oral feeding to animals’. The feed chain is represented in Figure 3.1.

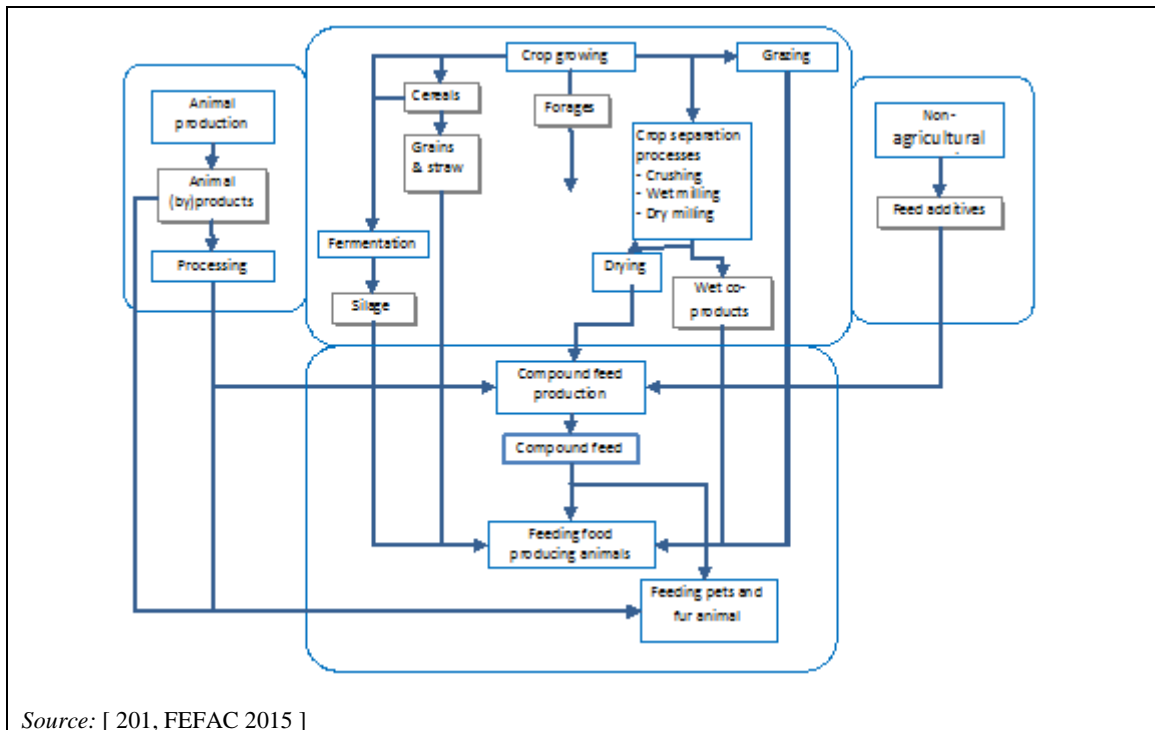

Source: [201, FEFAC 2015]

Figure 3.1: General overview of the feed chain

This chapter covers the production of the following types of feed:

- compound feed for food-producing animals;
- pet food;
- feed for fur animals;
- green fodder (dehydrated forage).

3.1 General information about the sector

3.1.1 Compound feed for food-producing animals

Farm animals in the EU-28 consume an estimated 475 million tonnes of feed a year (see Figure 3.2), of which 153 million tonnes are produced by compound feed manufacturers.

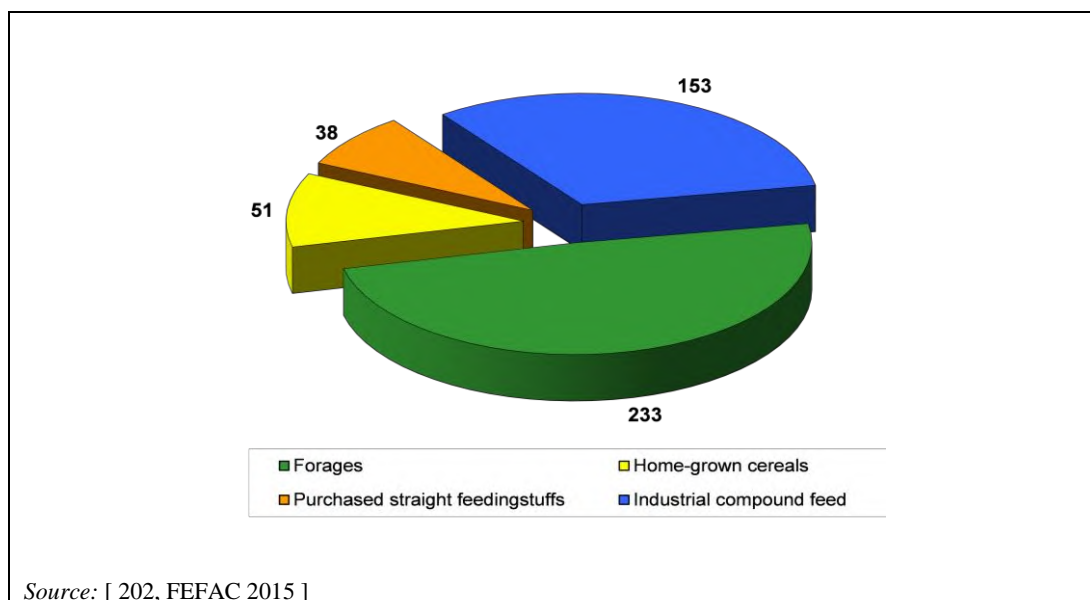

Figure 3.2: Origin of feed (in million tonnes) in the EU-28 in 2014

Compound feeds are composed of different feed ingredients, the inclusion rates of which are defined by recipes that vary depending on the animal species the feed is destined for and the prices of the ingredients. The main ingredients are feed materials such as cereals (e.g. wheat and barley, co-products from the food industry (e.g. soyabean meal, dehydrated sugar beet pulp), molasses, and vegetable oils or minerals (e.g. calcium carbonate). Other ingredients are feed additives (e.g. vitamins, technological additives). In the case of medicated feed, a veterinary medicine may be incorporated into the compound feed. Water is also added in the form of steam.

The purpose of compound feed manufacturing is to supply farmers with a product whose nutritional composition (vitamins, energy, proteins, amino acids, etc.) meets the requirements of the animals as much as possible to achieve predefined animal production criteria (e.g. amount of milk/day, daily live weight gain) at the lowest cost. Considering that the nutritional requirements of the animals depend on many parameters (e.g. species, sex, breed, age, physiological stage, production system), compound feed manufacturers may produce feed meeting up to 150 different predefined specifications at the same location. The vast majority of compound feed is produced in a dry form from raw materials in solid and dry form, with exceptions such as molasses or vegetable oils [202, FEFAC 2015].

The non-exhaustive EU Catalogue of Feed Materials (Regulation (EU) No 68/2013) lists more than 600 feed materials. Volume-wise, cereals represent just less than half of the feed materials used. The European feed industry also exploits a significant amount of co-products from the food industries. Of an average compound feed formula, 40 % is made up of these co-products (co-products from the food industry, cakes and meals) (see Figure 3.3). Regarding protein, the most important feed materials are soybean meal, mainly imported from third countries, and rapeseed meal, from the European crushing industry. The industry also uses protein-rich co-products from the starch and ethanol industries and digestible fibre-rich co-products from the beet sugar industry plus numerous liquid feeds. A large part of the feed ingredients used to feed

food-producing animals is of vegetable origin. However, dairy by-products are used significantly in milk replacers for young animals, in particular calves. Products of marine origin such as fishmeal, fish oil, krill, etc. are incorporated in fish feed, especially for carnivorous species. Due to the limited marine resources, fishmeal is increasingly replaced by proteins of vegetable origin and still, to a limited extent, processed animal proteins from poultry and/or pigs.

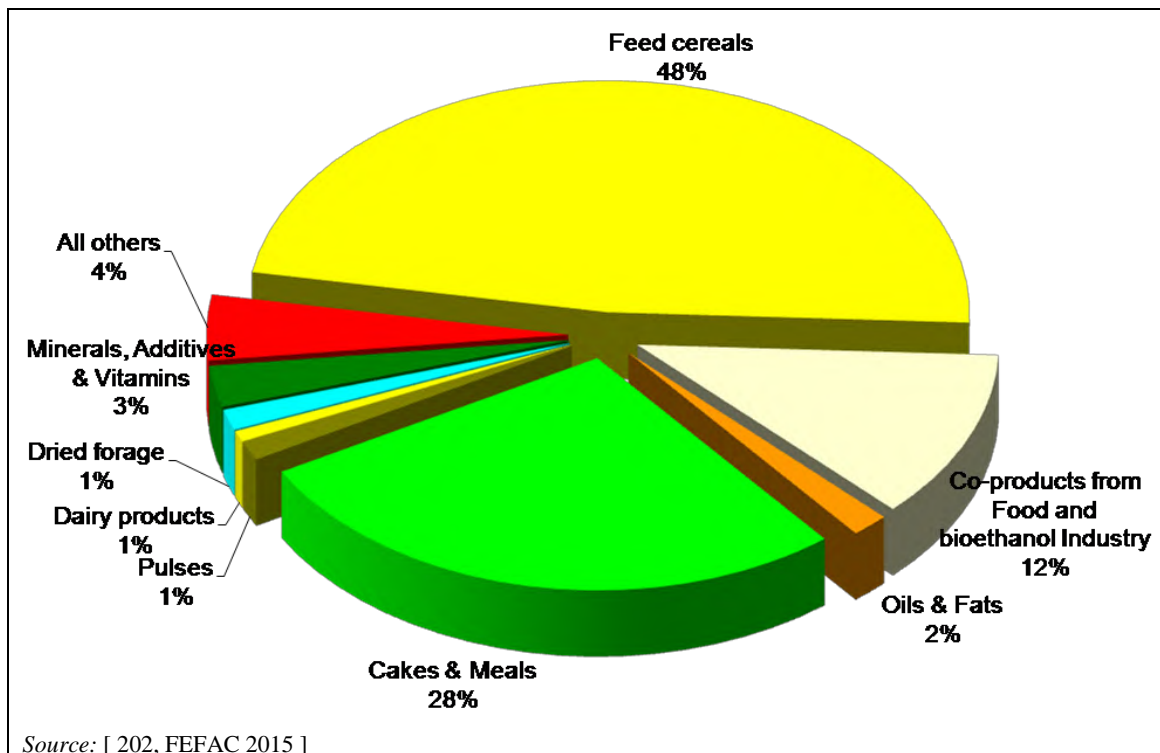

Figure 3.3: Feed materials in the EU-27 feed industry in 2014

The European compound feed industry is a growing industry and turnover is estimated at EUR 45 billion. It offers direct employment for approximately 110 000 people in approximately 4 500 installations. Many of these installations are situated in rural areas, which offer few employment opportunities. Most (85 %) of the (compound) feed installations are SMEs, with in 2012 an average annual production of 38 000 tonnes of compound feed per installation. The number of production installations falling under the scope of the FDM BREF is estimated to be around 450 [202, FEFAC 2015].

The manufacturing of compound feed for food-producing animals is characterised by the fact that it is performed in a dry environment: the feed manufacturing process does not involve water (except for steam production during pelleting or thermal treatment) and cleaning is performed in a dry environment. This means that there is no water release into the environment.

The following list identifies key environmental impacts of manufacturing of compound feed for food-producing animals:

- emissions to air: particulates from processing (cooling), loading and unloading of materials, failure of arrestment equipment / odour (for feed containing a minimum of 5 % animal proteins) from processing (pelleting, cooling), loading and unloading of materials
- energy: use of energy in feed processing;
- noise: vehicles and process operations may cause noise disturbance, especially if close to the site boundary.

Noise and odours are mainly incidental and tend to be relevant to the relatively few compound feed installations occupying inhabited areas. These emissions can be minimised by good management practice and can be legitimately considered at local level [225, FEFAC 2015].

3.1.2 Pet food

Pet food contributes significantly to the economy and to society. Throughout Europe, an estimated 50 000 direct and 700 000 indirect jobs are generated by the pet food industry. A total number of about 650 pet food installations are spread all over Europe. The pet food industry and related supply and services represent a combined annual turnover of over EUR 30 billion. Pet food products serve approximately 75 million pet-owning households with an annual pet food production of over 9 million tonnes [203, FEDIAF 2015].

In order to define their formulations as precisely as possible, manufacturers rely on the analysis of nutritional requirements of pets. In R&D centres, manufacturers, nutritionists, biochemists, microbiologists and veterinarians study animal nutrition. They also measure the nutritional value, palatability and digestibility of feed materials used in the formula which constitutes the basis of production.

The nutrients used in products are found in animal-based ingredients, cereals and vegetables or are supplied in the form of supplements. The industry therefore uses animal by-products or leftovers from the fish filleting industry mixed with vegetable materials (e.g. cereals, legumes).

There are two major processes for producing pet food. The majority of produced foods are complete feeds, whether in dry or wet form. The typical characteristic of a wet food is a moisture content of 60 % or more. This requires specific technical preparations and procedures for stabilising and securing the final product in cans, pouches and metal trays. Dry pet food has up to 14 % moisture and is therefore, in terms of handling, packaging and transport, closer to some agricultural products in bags (paper/plastic) or boxes [203, FEDIAF 2015].

Dry pet food is approximately composed of 86 % raw materials and 14 % moisture while wet pet food can contain more than 60 % moisture.

The following list identifies key environmental impacts of pet food processing [203, FEDIAF 2015]:

- emissions to air: particulates and odour from processing (grinding, heating, cooling), loading and unloading of materials, failure of arrestment equipment;
- energy: use of energy in pet food processing;
- noise: vehicles and process operations may cause noise disturbance, especially if close to the site boundary;
- water and waste water: as raw material and for process cleaning.

3.1.3 Feed for fur animals

The European fur animal feed industry serves around 4 000 fur farms in Europe, including mink, fox, and Finn raccoon farms, for a total amount of 41.6 million animals bred [46, FEFAC 2017].

Besides the years of experience they carry, fur feed kitchens continuously invest in R&D to update and develop fur feed. The formulations are the result of the close cooperation between manufacturers, nutritionists, chemists, fur farmers, veterinarians, who base their work on biological evidence and analysis of the animals' nutritional needs. Nutritional values, as well as criteria like palatability and digestibility of feed materials, are taken into consideration during this work. In some cases, fur farms might have specific needs and challenges affecting animal feed, and feed kitchens liaise directly with farmers in order to design specific products based on

their demands. In some countries, national authorities demand that specific requirements are respected [46, FEFAC 2017].

Fur animal feed contains dried proteins, and nutrients coming from animal-based ingredients (poultry, fish, and beef leftovers, swine fat) and vegetable-based ingredients (soya products, soybean oil, maize products, wheat, barley, corn and potato proteins).

Feed for fur animals is produced in a wet form, but raw materials are used in many forms: some are supplied fresh, e.g. raw material coming from the trimming of fish leftovers; while in other cases the raw materials are supplied frozen; finally, other raw materials are supplied as dried powders or in a liquid state. All raw materials are then combined to form a paste suitable for feeding the fur animals, via crunching, chopping, grinding, milling, weighing and mixing processes [46, FEFAC 2017].

The following list identifies key environmental impacts of manufacturing of feed for fur animals:

- energy use: use of energy in feed processing;
- water: use of water and waste water discharges;
- noise: machinery operations and vehicles travelling to and from the industrial installation may cause some noise disturbance;
- air/smell: odours linked to production and/or sludge collection.

3.1.4 Green fodder (dehydrated forage)

The industry producing green fodder, also known as dehydrated forage, operates in rural areas with market demand. Spain is the leading European producer of dehydrated alfalfa, the main product in the sector, ahead of France and Italy. The French sites stand out for their high combustion capacities and the weather limiting the potential for drying the fodder in the fields before it is processed in the installations [157, Copa-Cogeca 2016].

Direct flame combustion or high-temperature drying is used to directly process incoming material. Most of these installations were set up in the 1960s under the legal form of farming cooperatives. They are therefore owned by their member farmers who manufacture a large number of products: alfalfa, other leguminous plants, grasses, other green fodder, corn, poppyseeds, carrots, straw, unripe hay, etc. Most of the sites also handle by-products from nearby industries in order to extend the campaign for longer and make better use of their production tools: sugar beet pulp with the sugar industry, grape marc with distilleries, pomace with cider producers, mustard bran with mustard producers, and so on. Some even operate during the winter campaign, using sawdust, miscanthus, and short-rotation bushes to manufacture biofuels.

3.2 Applied processes and techniques

3.2.1 Compound feed for food-producing animals

3.2.1.1 General

Generic steps in the manufacture of compound animal feeds are as follows:

- reception and storage of raw materials;
- size reduction of raw materials;
- processing of materials;
- product storage and dispatch;
- cleaning activities.

Equipment common to this sector includes:

- storage silos, hoppers and tanks for the containment of stored materials;
- grinders for the size reduction of material prior to processing;
- conveyance systems for the contained transportation of material;
- mixers to allow the creation of batches of feed mixtures with preset formulations;
- conditioning units in which the feed mixture undergoes steam treatment;
- press lines in which the conditioned feed materials are pelleted through dies to achieve the desired product conformation;
- coolers which utilise air to cool the product materials prior to storage;
- storage silos and bins for the storage of processed materials;
- boilers for the production of steam;
- dust abatement systems.

A generic schematic of the activities undertaken in the manufacture of compound animal feeds is provided in Figure 3.4.

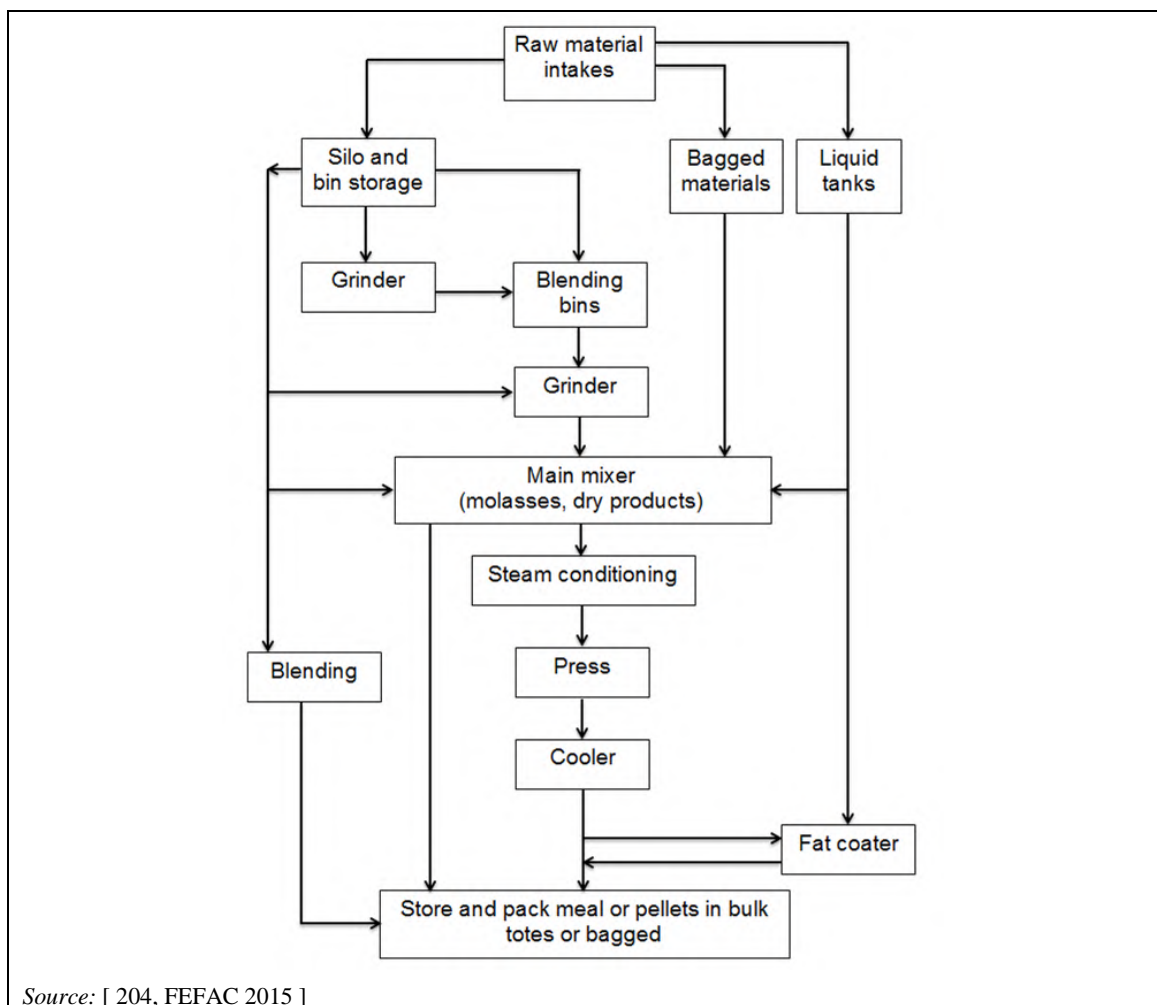

Figure 3.4: Activities undertaken in the manufacture of compound animal feed

3.2.1.2 Receipt and storage of raw materials

The methods used for the storage and handling of the raw materials are specific to the individual materials [204, FEFAC 2015]:

- Bulk solid raw materials (e.g. cereals) are generally delivered to the site in covered vehicles and tipped into reception hoppers prior to conveyance to silos or bulk bins for storage. Other bulk powders (e.g. amino acids) are delivered by tanker and are blown directly, by tube, into dedicated storage silos.
- Bulk liquid raw materials (e.g. molasses, soya oil and vegetable oil) are delivered by road tankers and are pumped into designated, bunded storage tanks.
- Packed solid and liquid raw materials (such as vitamins and enzymes) are stored internally within a warehouse facility in the supplier's primary packaging plant prior to use.

3.2.1.3 Size reduction of raw materials

In order to ensure the homogeneity of the finished product and to produce the physical attributes required, the raw materials are ground and sieved prior to inclusion in the product mixture. Typically, electrically driven grinders are used to grind the material to a uniform particle size. Once ground, the raw material is conveyed to the processing plant by means of enclosed conveyors [204, FEFAC 2015].

3.2.1.4 Processing of raw materials

Weighing and mixing

Raw materials are fed via load cells into a batch mixer. A typical site will have a number of mixers which are dedicated to specific product types to prevent cross-contamination. At this stage of the process, the low-dose ingredients, such as feed additives or premixtures of feed additives, are added directly into the mixer. Depending upon the recipe, liquid additives and water can also be weighed and added into the mix via dedicated lines at this stage.

Mixing is typically performed within a horizontal enclosed continuous mixer. The residence time for the mixing process is recipe-specific and, when the mixing cycle is complete, the homogeneous batch is conveyed for further processing in the press plant. However, if a meal product is being produced, the batch will be transferred directly from the mixer to a finished product bin, ready for dispatch [204, FEFAC 2015].

Steam treatment

Steam treatment or conditioning is the process of adding steam directly into the mix to raise its temperature so that any bacteria present (such as *salmonella*) are eliminated. The steam also improves the physical characteristics of the mix in preparation for the subsequent pelleting process. At this stage, further liquid materials (such as molasses) may be added as required. The length of the conditioning process is determined by the requirements of the feed being produced [204, FEFAC 2015].

Installations operate a dedicated boiler plant to provide the steam to the production process.

Pelleting

After conditioning, the hot mix is conveyed to a press line; a typical installation will have a number of press lines dedicated to the production of a specific compound feed. A screw feeder is used to force the mix into a press whereupon it is extruded through a rotating ring die to form a pellet product. Different die dimensions and press rotation speeds facilitate the production of different pellet sizes, to meet specific product requirements [204, FEFAC 2015].

Cooling

After pelleting, the hot product is then passed through a counterflow air cooler to reduce its temperature, causing it to harden and become durable. The cooling process involves air at ambient temperature being passed directly over the pellets.

Additional processing steps may be utilised after cooling to produce specific products. The pellets may be crushed to produce feeds for poultry, or undergo fat coating prior to storage [204, FEFAC 2015].

3.2.1.5 Product storage and dispatch

Once cool, the finished product is conveyed to dedicated finished product silos or tote bins, prior to dispatch. Silos are fitted with high level alarms to prevent overfilling.

The product is typically dispatched in bulk, although some installations also operate bagging stations to facilitate the creation of packaged products to meet small-scale demand. Bulk product is loaded onto dedicated delivery lorries prior to dispatch to customers. Loading activities are typically undertaken in enclosed bays to limit the potential for the fugitive release of dust and odour [204, FEFAC 2015].

3.2.1.6 Cleaning activities

Cleaning and housekeeping activities are essential at compound animal feed manufacturing installations to guarantee food hygiene and to ensure that cross-contamination of different feedstuffs cannot occur. Cleaning of the installation and processing equipment does not generally involve wet cleaning; it typically involves dry, mechanical processes only (sweeping and vacuuming). Most installations also operate a dedicated on-site vehicle washing facility to clean the lorries used for bulk deliveries to customers [204, FEFAC 2015].

3.2.2 Pet food

3.2.2.1 General

Generic steps in the manufacture of pet food are as follows:

- reception and storage of raw materials;
- size reduction of raw materials;
- processing of raw materials;
- product storage and dispatch;
- cleaning activities.

Equipment common to this sector includes:

- silos, hoppers, freezing/cooling equipment (wet products) and tanks for the containment of stored materials;
- grinders for the size reduction of material prior to processing;
- conveyance systems for the contained transportation of material;
- mixers to allow the creation of batches of feed mixtures with preset formulations;
- processing units:
 - wet food: preparation of solid and liquid parts for final products (product shape; pieces in gravy, pieces in jelly mousse, pâté), container-filling machines, steriliser;
 - dry food: extruders (product shape; kibbles, in different dimensions), spray coating dryers.
- coolers;
- storage facilities for the intermediate storage of processed material (pallets);
- boilers for the production of steam;
- dust abatement systems;
- waste water treatment facilities;
- odour treatment.

A generic schematic of the activities undertaken in the manufacture of pet food is provided in Figure 3.5.

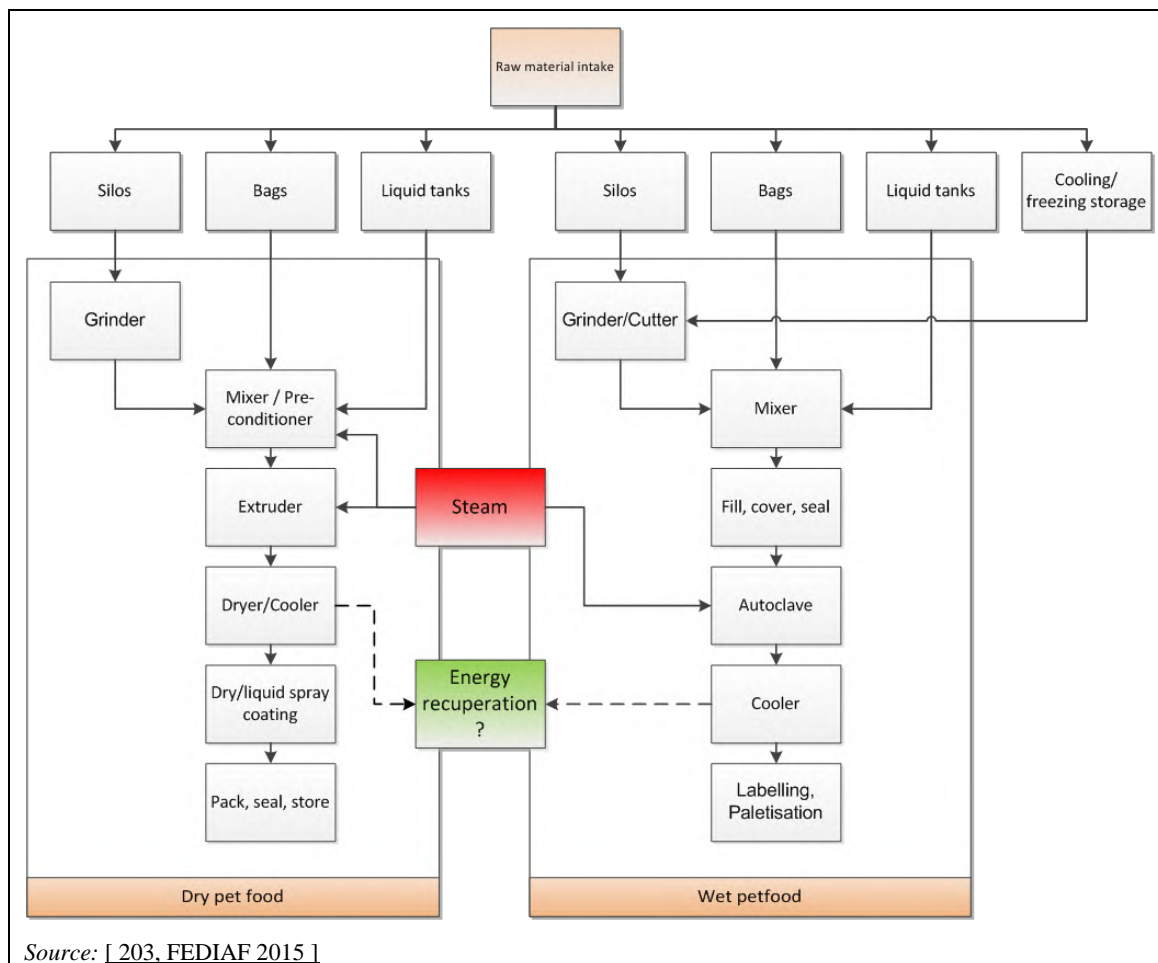

Figure 3.5: Manufacture of pet food

3.2.2.2 Receipt and storage of raw materials

Pet food is based upon core formulations of cereals (such as wheat and barley), animal by-products as the protein source (Category 3 materials; fresh, frozen, dried; from animals passed as fit for human consumption), vegetables, liquid ingredients (such as water and oils) and specific additives such as mineral supplements. The methods used for the storage and handling of raw materials are specific to the individual materials [203, FEFAC 2015]:

- Bulk solid raw materials (e.g. cereals) are generally delivered to the site in covered vehicles and tipped into reception hoppers prior to conveyance to silos or bulk bins for storage. Other bulk powders (e.g. minerals) are delivered in big bags or by tanker and blown directly into dedicated storage silos.
- Bulk liquid raw materials (e.g. animal and vegetable oil) are delivered by road tankers and are pumped into designated storage tanks.
- Packed solid and liquid raw materials (such as vitamins and enzymes) are stored internally within a warehouse facility in the supplier's primary packaging prior to use.

3.2.2.3 Size reduction of raw materials

In order to ensure the homogeneity of the finished product and to produce the physical attributes required, the raw materials are ground and sieved prior to inclusion in the product mixture. Typically, electrically driven grinders and/or cutters are used to grind the material to a uniform particle size. Once ground, the raw material is conveyed to the processing plant by means of enclosed conveyors [203, FEFAC 2015].

3.2.2.4 Processing of raw materials

Weighing and mixing

Raw materials are fed via load cells into a batch mixer. A typical site will have a number of mixers which are dedicated to specific product types to prevent cross-contamination. At this stage of the process, the low-dose ingredients, such as feed additives or premixtures of feed additives, are added directly into the mixer. Depending upon the recipe, liquid additives and water can also be weighed and added into the mix via dedicated lines at this stage [203, FEFAC 2015].

For dry products, mixing is typically performed within a horizontal enclosed continuous mixer. The residence time for the mixing process is typically three to four minutes and, when the mixing cycle is complete, the homogeneous batch is conveyed for further processing.

For wet products, mixing is typically performed in a vertical mixer in batches. The mixture will be poured directly into the final containers.

Extrusion (dry pet food)

This process has become the most common for dry pet food. An extruder consists of a tightly fitting screw rotating within a stationary barrel. Pre-ground and conditioned ingredients enter the screw feeder where they are conveyed, mixed and heated by a variety of processes. The product exits the extruder through a die where it usually changes texture due to the release of steam and normal forces. A variety of food extruder designs have been developed [203, FEFAC 2015].

Extrusion is a quick high-temperature process which minimises losses in vitamins and amino acids. Colour, flavour and product shape and texture are also affected by the extrusion process. Extrusion has been widely applied in the production of nutritious foods. Emphasis is placed on the improvement of protein quality and digestibility. This process makes the product highly digestible as it ensures the complete cooking of the starch.

After the extruder, the product goes into the dryer in order to reach the target moisture, and then continues into the cooler. Dry foods may then be sprayed with liquids in order to complete their composition and increase palatability without degradation during extrusion.

Figure 3.6 shows a typical scheme of the manufacture of dry pet food.

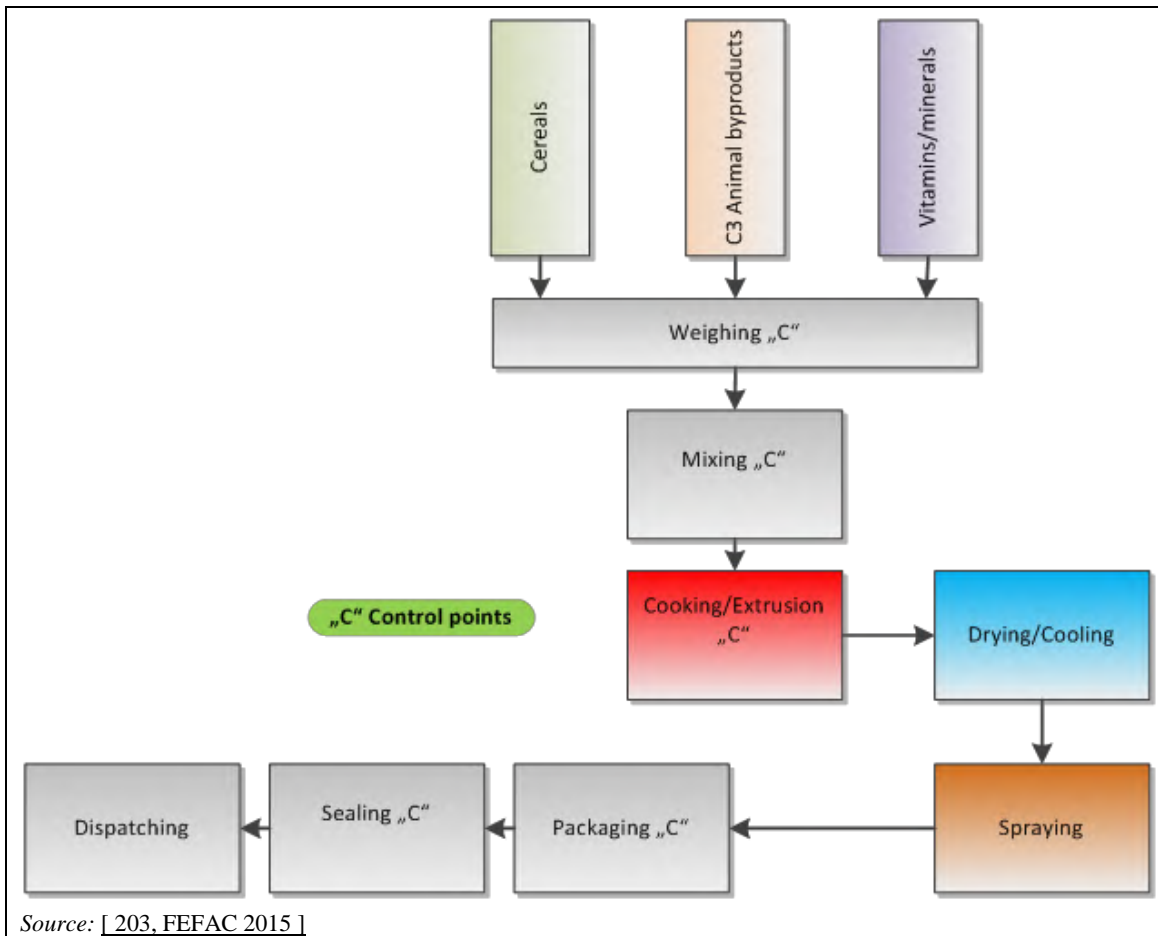

Source: [203, FEFAC 2015]

Figure 3.6: Manufacture of dry pet food

Sterilisation (wet pet food)

After conditioning and mixing the different ingredients (texture, size, density, liquid, solid, etc.), the final containers are filled, closed and finally sterilised.

Figure 3.7 shows a typical scheme of the manufacture of wet pet food.

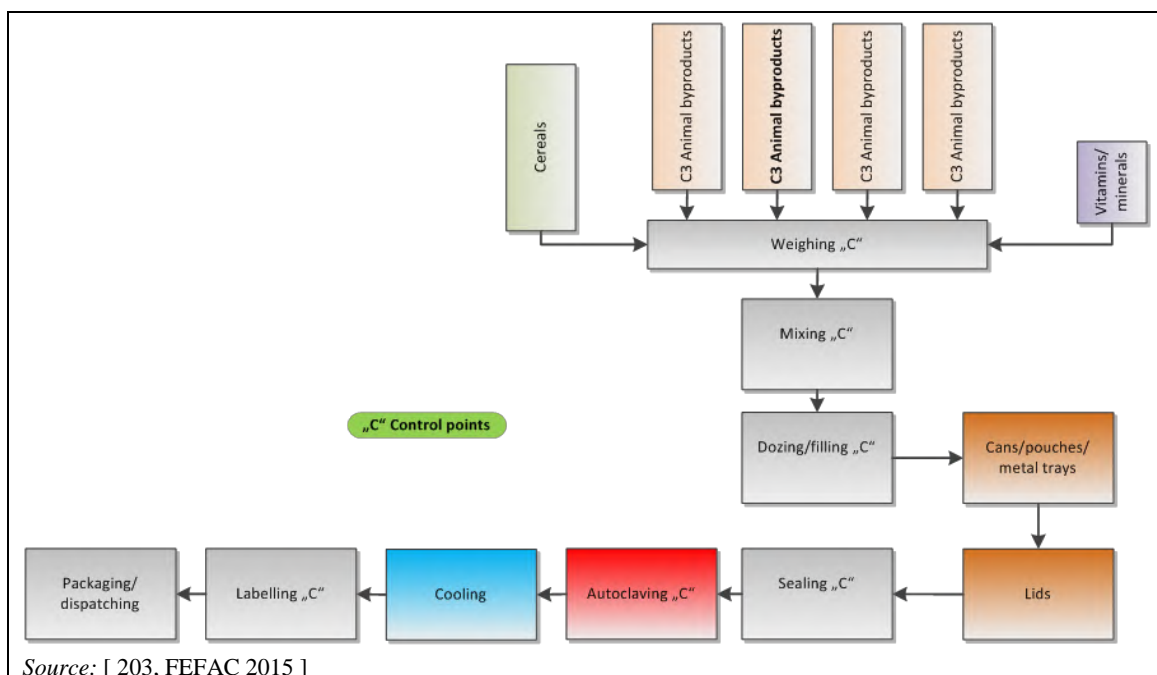

Figure 3.7: Manufacture of wet pet food

Cooling

After processing, the hot product is then passed through a counterflow air cooler or a cooling tower to reduce its temperature [203, FEFAC 2015]:

- dry pet food: cooling/drying enables pellets to harden and become durable;
- wet pet food: cooling towers, using water, are used to cool down sterilisers or products after sterilisation.

Additional processing steps may be utilised after cooling to produce specific product characteristics (e.g. fat coating of pellets) prior to packaging and storage.

3.2.2.5 Product storage and dispatch

Finished packed and labelled products are stored on pallets.

3.2.2.6 Cleaning activities

Cleaning and housekeeping activities are essential at pet food production sites to guarantee food hygiene and to prevent cross-contamination. Most installations also operate a dedicated on-site vehicle washing facility to clean the lorries used for bulk deliveries to customers.

3.2.3 Feed for fur animals

3.2.3.1 General

Generic steps in the manufacture of feed for fur animals are as follows:

- reception and storage of raw materials;
- processing of materials into the final product;
- storage and dispatch of the final product;
- cleaning activities.

The equipment common to this sector includes:

- silos, freezing and cooling equipment, tanks;
- crusher, chopper;
- weighing system;
- mixer;
- homogeniser;
- conveyor belts for transportation of material;
- tanker trucks for delivery to the customers;
- emission abatement systems;
- waste water treatment facilities.

A generic schematic of the activities undertaken in the manufacture of feed for fur animals is provided in Figure 3.8.

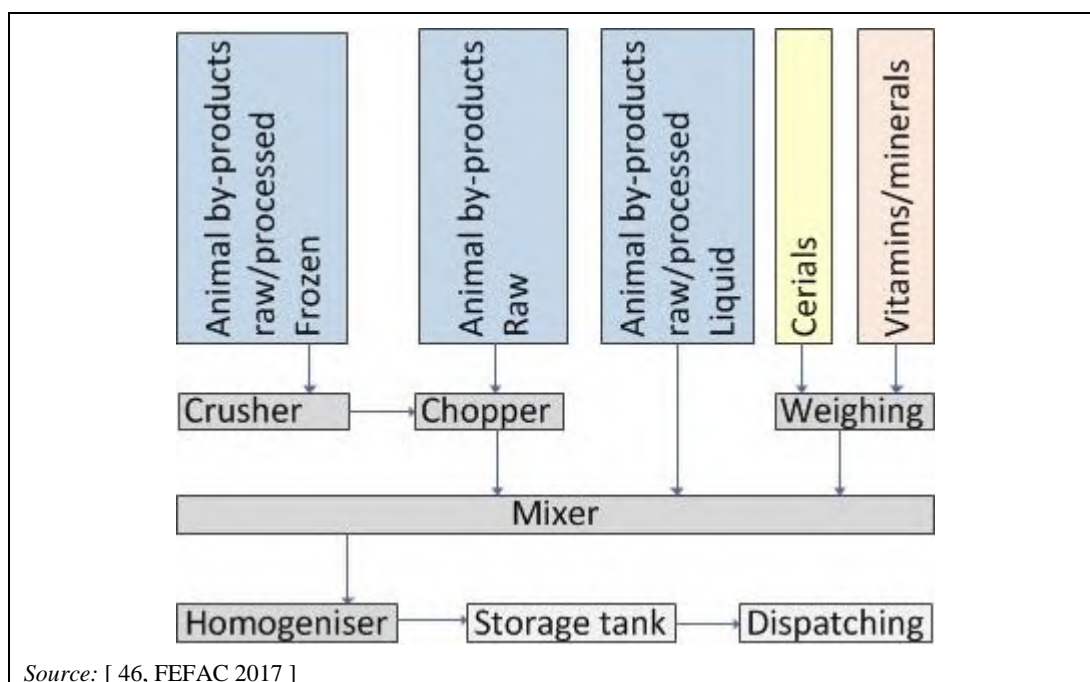

Figure 3.8: Manufacture of feed for fur animals

3.2.3.2 Receipt and storage of raw materials

Raw material is usually transported to the factory by truck. Depending on the equipment present in the industrial installation, feed kitchens receive both fresh, cooked and frozen raw material and grain products daily. Fresh materials are either directed straight into the feed production process or they are frozen. Frozen raw material is stored in freezers. Dry material is stored in silos and tanks. Many feed kitchens freeze part of the raw materials for later use (e.g. during high production season). Some feed kitchens also provide freezing and storing services for smaller installations that do not have dedicated equipment [46, FEFAC 2017].

3.2.3.3 Processing of materials into the final product

Weighing and mixing

Frozen raw materials are usually thawed for 12 hours before use. The frozen product is crushed and the fresh product is chopped. Wheat is milled to flour before the mixing phase. Dry and wet material are mixed. The weighing equipment is usually connected to the silos and/or mixer. Water is added to the mixture to reach the desired consistency. The resulting product is then homogenised [46, FEFAC 2017].

Cooling

The cooling is achieved naturally by using frozen or semi-frozen raw materials.

3.2.3.4 Storage and dispatch of the final product

The finished product is directed to specific finished product silos or tanks in the installation prior to dispatch. From the silos, the finished product is collected by insulated tanker trucks that keep it at a cool temperature (between 0-4 °C) during transportation. The trucks deliver the finished product directly to the customers [46, FEFAC 2017].

Normally, the feed is dispatched as soon as it is ready and a tanker truck is ready. The feed is normally dispatched within a few hours after production and used/fed to the animals the same day.

3.2.3.5 Cleaning activities

Extreme care is given to cleaning activities on the installation premises, in order to guarantee high hygiene standards. Feed kitchens are cleaned after each production cycle. In some cases the cleaning activities fall directly under the responsibility of the installation management, while in other cases they are outsourced to specialised service providers. All the production equipment is washed, and the machinery is foamed, washed and disinfected with antiseptics [46, FEFAC 2017].

3.2.4 Green fodder (dehydrated forage)

3.2.4.1 First stages

The improvement of operating stand-alone dehydration units involves controlling their supplies. In order to ensure the unit operates as regularly as possible and to reduce the number of incidents or stoppages, which are always costly, harvesting in the alfalfa fields takes place during the periods in which the units are operating, in other words round the clock.

The first stage on a field site is mowing the alfalfa. Until recently, rakes were used and the alfalfa was gathered afterwards to conserve product quality, the average humidity rate of which was reduced from 80 % to 75 % when entering the unit. Apart from the harvesting constraint

this implied, such practice reduced the drying capacity of sun-dried products. Therefore, an intermediary stage has been included in the process in the form of flat pre-wilting which requires maintenance of the farming machinery used for this purpose, i.e. rakes. The mown alfalfa is lifted up from underneath by rakes that spread it over a rolling belt that expels it out of the machine to the sides. The alfalfa is then spread flat over the field, where it dries better due to the larger surface specifically exposed to the sun. The silage is then carried out 24 to 48 hours after the cutting process, depending on the weather conditions and the unit needs for supplies. This flat pre-wilting technique does not lower the quality of the finished product and enables up to 30 % energy savings to be achieved by the unit due to the lower humidity level of the input products [157, Copa-Cogeca 2016].

3.2.4.2 Dehydration by the high-temperature dry process

The high-temperature dry process consists of producing dehydrated alfalfa pellets or bales with 10 % to 12 % humidity using raw material with humidity that varies from 25 % to 85 %, depending on the treatment it receives in the fields and the humidity conditions at the time of harvesting. It is also used for other kinds of fodder. The alfalfa, pre-wilted or not in the field, is dried at a high temperature in single- or three-pass rotary furnaces. The shorter three-pass rotary drums (see Figure 3.9) are adapted to high humidity levels because the passes through the drum are more frequent, the exchange volumes being greater. They are fed with heat from the grill burners. The fuel used is coal, lignite, gas or, more recently, some kinds of biomass such as woodchips, sawdust or miscanthus [157, Copa-Cogeca 2016].



Source: [157, Copa-Cogeca 2016]

Figure 3.9: Three-pass drying drum

The furnace pipe temperatures vary according to the humidity of the incoming products and vary between 300 °C and 950 °C depending on the product in question. When exiting the drum, the temperature of the output fumes is about 120 °C. Fodder is dehydrated with surplus air, in particular for the purpose of creating a flow to allow its correct circulation in the dryer. The air contains water vapour when exiting the dryer. The products are separated from this humid gas by high-performance cyclone separation. When leaving the cyclone, the humid gas from the drum can be directly expelled into the atmosphere or be partially used in various recycling processes in order to reduce energy consumption [157, Copa-Cogeca 2016]:

- partial recycling upstream to be injected into the air burner which is already hot;
- recycling to a fodder predryer through a condenser scrubber;
- recycling in a wet process using vacuum evaporators.

The dehydrated alfalfa husks are either pressed into bales or processed in pellets. In order to manufacture pellets, the alfalfa from the cyclone is normally crushed in hammer mills. The outgoing product is transported by suction, then separated by cyclones and the waste is passed through bag filters or treated in the wet process. The desired moisture of the output alfalfa from the furnace is about 15 % in order to obtain a moisture content of about 12 % for the pellets from the presses, and 12 % to ensure the best preservation of bales.

Due to the risk of fire, ongoing monitoring of input and output product temperatures is conducted in the dryer, with detection of sparks and engine rotation. Alarms, a circuit sprinkler and automatic stoppage of the drying line are implemented.

Optimising the operation of the production line, in particular adjustment of the required temperatures (input and output) of the dryer to the humidity rate of the alfalfa, enables the optimisation of the energy consumption. The direct flame drying process does not cause a loss of heat.

3.2.4.3 Dehydration by the wet process

There is a twofold objective for using the wet process: to produce protein-concentrated pellets and xanthophyl and carotenoid pigments and to save energy. The freshly cut alfalfa is harvested without pre-wilting, and crushed and pressed to extract the protein-rich sap, called green juice. The cake, a by-product from the pressing stage, is transferred to the dry process. The juice is heated by steam at 85 °C in order to coagulate the proteins into coagulum, proteins that are then separated from the serum by centrifugation (see Figure 3.10).



Source: [157, Copa-Cogeca 2016]

Figure 3.10: Centrifuge system in a dehydration site

The coagulum, rich in proteins and pigments, is dried in a fluidised bed dryer and then compacted into pellets in the presses. After cooling, the pellets are stored at a cold temperature (5 °C) or rendered inert with nitrogen in order to preserve the pigments. The serum is concentrated by vacuum evaporation. Once concentrated, when the serum reaches 45 % dry content, it is returned to the cake which is returned to the high-temperature dryers in the dry process [157, Copa-Cogeca 2016].

3.3 Current consumption and emission levels

3.3.1 Energy consumption

Figure 3.11 shows reported data on specific energy consumption (MWh/tonne of products). A distinction is also made between the installations according to the different products they produce. Among the related techniques reported, heat recovery from condensation of hot gases, boiler economisers, use of variable speed drivers on motors and insulation of pipes are reported.

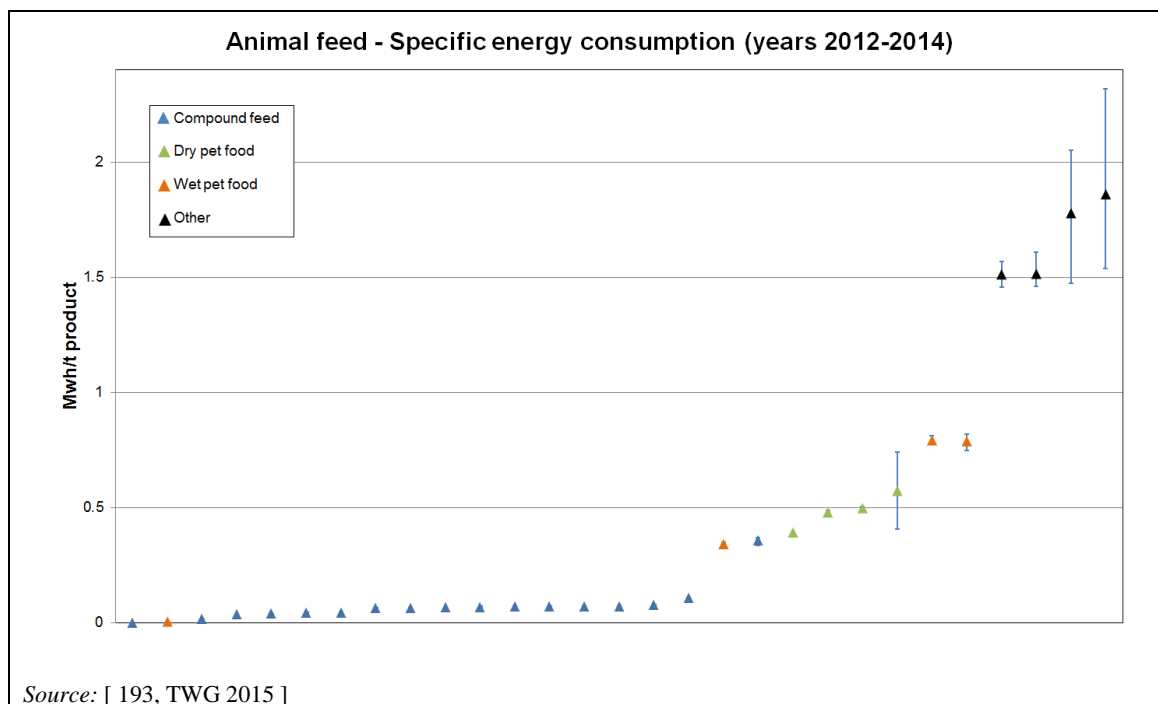

Figure 3.11: Specific energy consumption (MWh/tonne of products) in animal feed production

Pelleting and heat treatment for *salmonella* decontamination are relevant activities in terms of energy consumption for the production of compound feed [98, TWG 2017].

3.3.2 Water consumption

Table 3.1 shows reported data on specific water consumption (m^3/tonne of raw material). Generally, low specific water consumption values have been reported for compound feed production.

Table 3.1: Specific water consumption in animal feed production

Type of animal feed	Specific water consumption (m^3/tonne of products)
Compound feed production	0.001–0.909
Dry pet food production	0.406–0.506
Wet pet food production	2.64–4.88

Source: [193, TWG 2015]

3.3.3 Emissions to water

Figure 3.12 shows reported data on specific waste water discharges (m^3/tonne of products) from animal feed installations and all types of discharges. A distinction is also made between the installations according to the different products they produce. Higher specific waste water discharge values are generally reported in the case of wet pet food production. The production of dry pet food generates waste water with a COD concentration around 125 mg/l, while the production of wet pet food generates waste water with a COD concentration around 60 mg/l. More information on emissions to water can be found in Section 2.2.3.

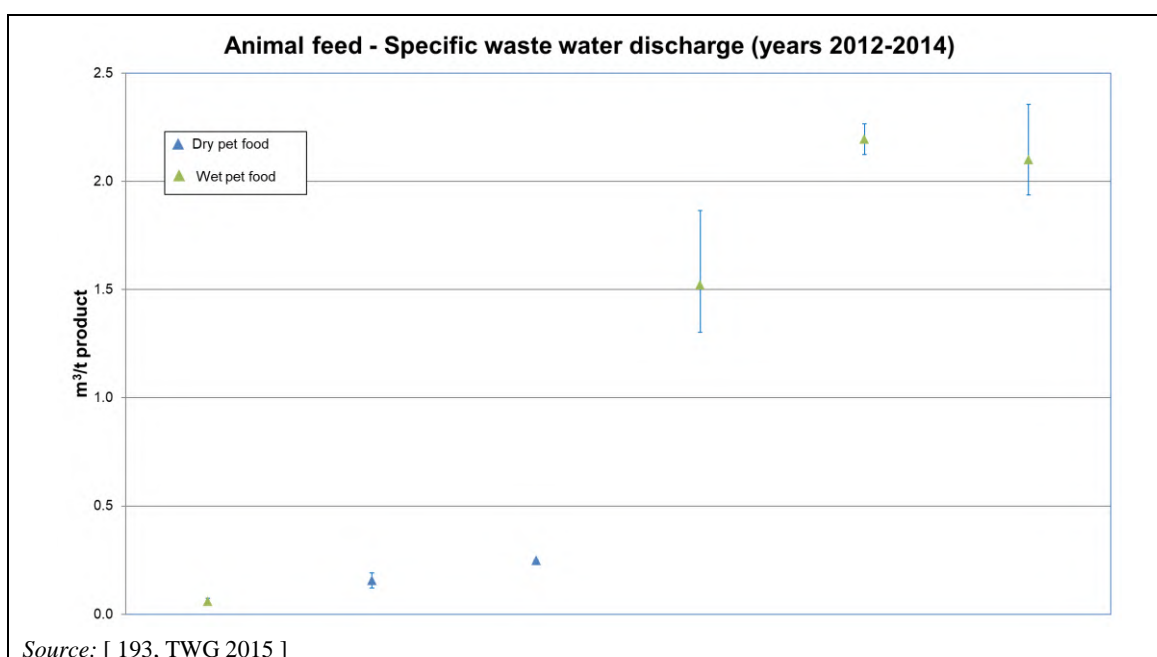

Figure 3.12: Specific waste water discharge in animal feed production (m^3/tonne of products) for all types of discharges

3.3.4 Emissions to air

3.3.4.1 Dust emissions from green fodder drying

The reported data related to dust emissions from green fodder drying are shown in Table 3.2.

Table 3.2: Total dust emissions to air from green fodder drying (dry basis)

Installation ID-point of release	Dust (mg/Nm^3)	O ₂ (%)	Frequency of monitoring	Monitoring standard	Sampling duration (h)	Abatement technique
292-1	116.25	17.45	Monthly	NA	0.50	Cyclones and wet scrubbers
264-1	151.02	17.50	Monthly	EN 13284-1	0.33	Cyclones
265-1	184.25	16.40	Monthly	EN 13284-1	0.50	Cyclones

NB: NI = no information provided.
Source: [193, TWG 2015]

3.3.4.2 Dust emissions from compound feed manufacturing

A general overview of the data received for dust emissions from compound feed manufacturing is shown in Figure 3.13 (lower values) and Figure 3.14 (higher values). The applied end-of-pipe abatement techniques are also indicated. The predominant monitoring standard reported was EN 13284-1 and the majority of concentrations were reported at atmospheric O₂ levels. The major sources of dust emissions are grinding and pellet cooling.

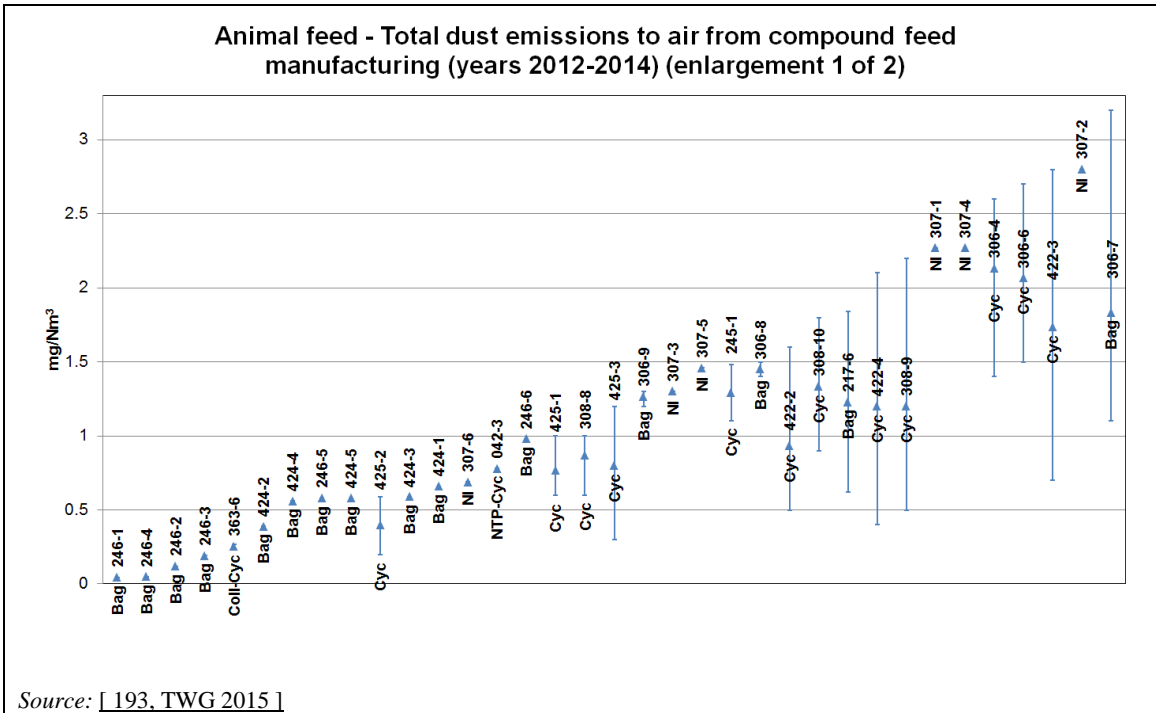

Figure 3.13: Total dust emissions to air from compound feed manufacturing (1 of 2)

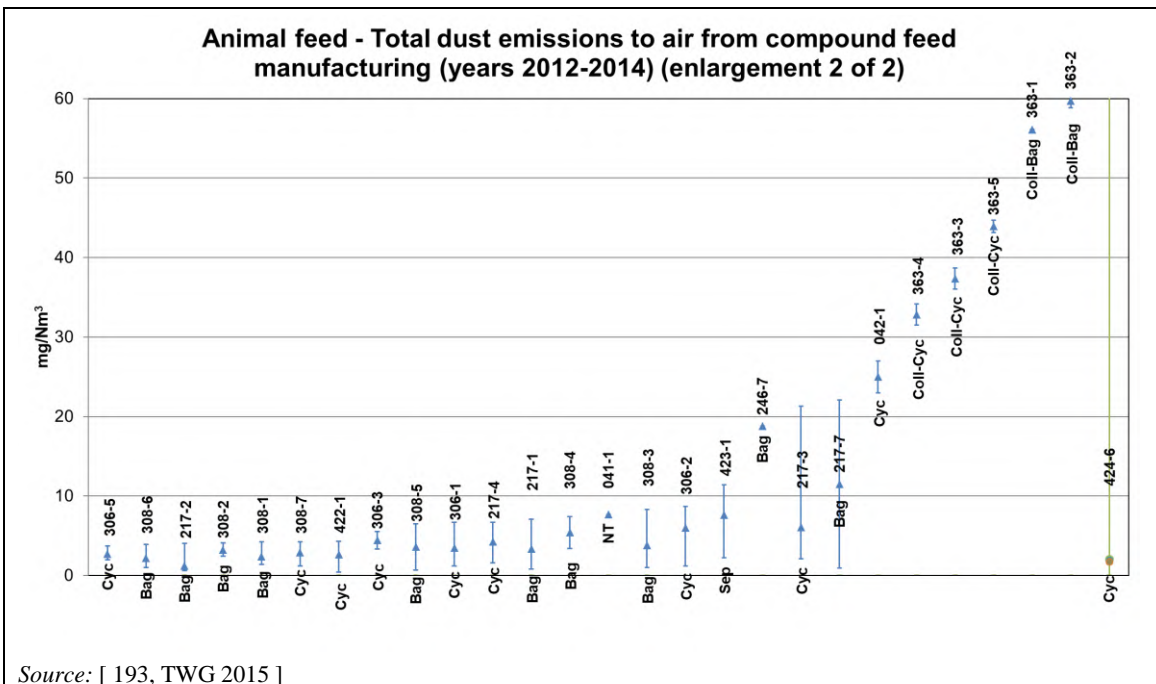

Figure 3.14: Total dust emissions to air from compound feed manufacturing (2 of 2)

The meaning of the symbols and abbreviations used in Figure 3.13 and Figure 3.14 are indicated in Table 3.3 and Table 3.4.

Table 3.3: Symbols used in the graphs for emissions to air







Symbol	Meaning	Type of monitoring regime
	Average of the emission levels over the period 2012-2014	Less frequent monitoring (less than 12 measurements per year)
		Frequent monitoring (at least 1 measurement per month)
		Continuous monitoring
	95th percentile of the emission levels for each reported year	-
	Maximum/minimum of the emission levels over the period 2012-2014	Less frequent monitoring (less than 12 measurements per year)
		Frequent monitoring (at least 1 measurement per month)
		Continuous monitoring

Table 3.4: Abbreviations used in the graphs for emissions to air

Abbreviations used in graphs and tables	Abatement technique for emissions to air
Ads	Carbon adsorption
Bag	Bag filter
Bflt	Biofilter
Bscr	Bioscrubber
Coll	Collection at source
Cyc	Cyclone
ESP	Electrostatic precipitator
Hexrec	Hexane recovery
NI	No information provided
NT	No treatment
NTP	Non-thermal plasma
Oilsc	Oil scrubber
Recirc	Recirculation of gases
Sep	Separator
TO	Thermal oxidation
Wetsc	Wet scrubber

3.4 Techniques to consider in the determination of BAT

3.4.1 Techniques to increase energy efficiency in green fodder drying

3.4.1.1 Use of predried fodder

Description

Use of fodder that has been predried (e.g. by flat pre-wilting).

Technical description

Predrying the fodder by flat pre-wilting consists of spreading the fodder flat after mowing to dry in the open air before harvesting it. This enables the humidity level of the input material in the dryer to be reduced more quickly than when using rakes, by improving the proportion of the product surface exposed to the sun. Flat pre-wilting is more efficient than pre-wilting using rakes. It is carried out with mowers and hay rakes specifically used for this purpose.

Flat pre-wilting requires traditional mowers to be adapted so that the mown alfalfa is placed flat on the field and not collected with rakes. Raking requires specific machinery and is only practical at the time of harvesting; therefore it is not used with mowing. This implies an additional use of machinery and thus extra costs (staff, specific machinery and fuel).

The variability of weather conditions has an impact on the continuity of the harvesting sites. As the raking stage is carried out after mowing, the most reliable weather forecasts are required in order to adapt the work in the event of rainy periods.

Apart from the weather conditions mentioned above, flat pre-wilting also depends on the following:

- the fodder humidity at the time of the mowing and raking work (e.g. flat pre-wilting is rarely carried out early in the morning (dew));
- the kind of equipment used (mower or adapted mower, which has an impact on the quality of the product harvested: the machinery will crush the product to a greater or lesser extent).

Achieved environmental benefits

Flat pre-wilting enables the humidity of the alfalfa entering the plant to be reduced compared with pre-wilting using rakes, to achieve an average fodder humidity of 60–70 %, which implies energy savings of about 30 %. Moreover, the following benefits are achieved [193, TWG 2015]:

- reduction in fuel consumption in the dryers of about 20–30 % (see Figure 3.15);
- reduction in emissions related to the reduction in the fuel combustion;
- reduction in NMVOC emissions (biogenic) to air of about 30 %.

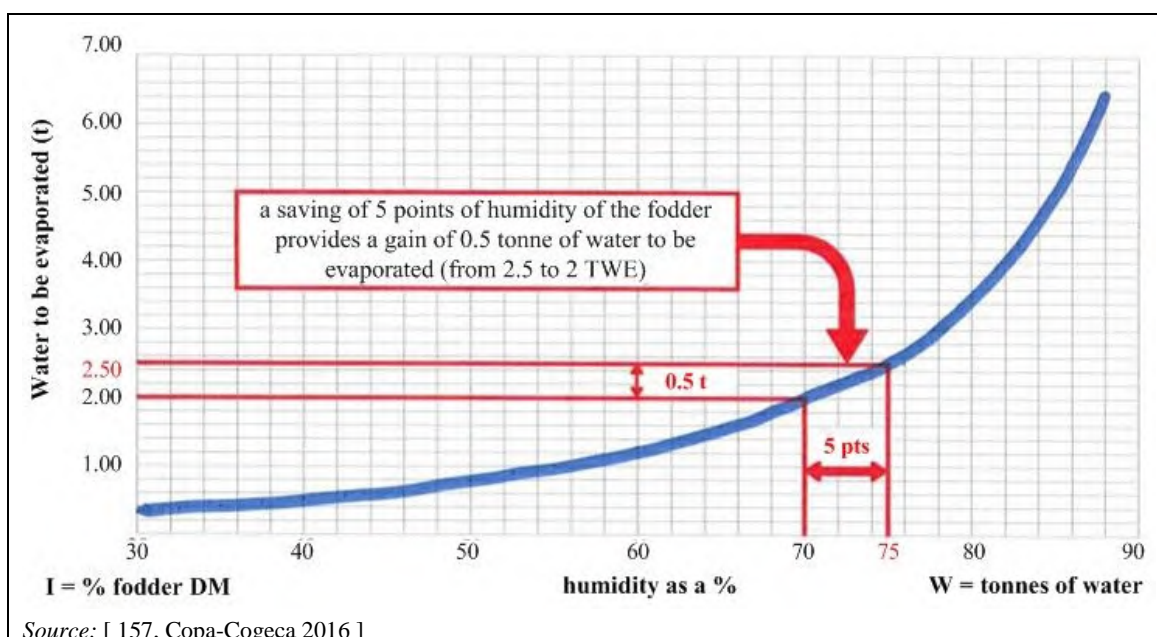

Figure 3.15: Tonnes of water to be evaporated depending on the humidity of the fodder for one tonne of pellets

Specific NMVOC emissions tend to be lower when the level of dry content in the fodder is higher. The NMVOC emissions are about 1.8 kg per tonne of product obtained from normally pre-wilted alfalfa (using rakes), compared with 1.2 kg NMVOC emissions per tonne of product obtained from flat pre-wilted alfalfa, which is equivalent to a reduction of more than 30 % in NMVOC emissions.

Environmental performance and operational data

No information provided.

Cross-media effects

Extra resources are required for spreading the fodder flat (staff, specific machinery and fuel).

Technical considerations relevant to applicability

Flat pre-wilting can be used in installations equipped with a high-temperature dryer and integral low-temperature dryer. The wet extraction process, which enables alfalfa protein concentrate to be obtained, needs a high water content, which is incompatible with flat pre-wilting.

Flat pre-wilting is sensitive to the moisture of the fodder during the mowing and raking work; however, it is rarely carried out early in the morning because of the dew. The kind of equipment used, a mower or mower-conditioner, crushes the product more or less, which affects its quality. A high number of stones on the land the alfalfa is to be collected from causes serious wear or even breakage of the harvesters, cyclones, hammers and drying equipment.

Economics

The costs incurred by this technique are partly related to the adaptation of equipment, fuel consumption and staff. One tractor-raking machine pair should be estimated to cover an area of 1 600 hectares of alfalfa. In terms of investment, the costs are as follows [157, Copa-Cogeca 2016]:

- raking machine purchase: about EUR 85 000, excluding taxes;
- tractor purchase: about EUR 78 000, excluding taxes;
- installation modifications: EUR 10 000–50 000, excluding taxes.

The cost of adaptation of the installation, mainly relating to fitting its equipment with stone removers, depends on the initial situation before implementing flat pre-wilting and the gap to be bridged in order to adapt it to the use of this technique. The annual operating costs are as follows [157, Copa-Cogeca 2016]:

- for a tractor: EUR 2 000, excluding taxes, for operational expenses (i.e. insurance, spare parts) and EUR 7 000, excluding taxes, for fuel (i.e. diesel);
- for a raking machine: EUR 7 000, excluding taxes, for upkeep and maintenance costs and EUR 20 000, excluding taxes, for employing a driver for the season;
- additional diesel to operate the rake: 11.8 l/hectare/year.

Driving force for implementation

Reduction in fossil fuel consumption.

Example plants

Installations #264, #265 and #292 [193, TWG 2015].

Reference literature

[157, Copa-Cogeca 2016], [193, TWG 2015]

3.4.1.2 Recycling of waste gas from the dryer

Description

Injection of the waste gas from the cyclone into the burner of the dryer.

Technical description

The volume of the primary air is less than the air needed in the drying drum. Therefore, additional air needs to be injected. Rather than injecting outdoor air, it is better to inject the outgoing waste gas from the cyclone, in order to save energy.

Recycling of waste gas increases dust emission levels expressed in concentrations. However, the pollution load remains the same. When the required temperature for the burner is lower, in the case of flat pre-wilted fodder, recycling of air must be optimised by ensuring that no over-pressure is created in the burner. Using flat pre-wilting reduces the need for recycling in small plants.

Achieved environmental benefits

This technique reduces energy consumption by decreasing the need for outdoor cold air supplies.

Environmental performance and operational data

When operating at high temperature with wet fodder, the recycling of 20 % of the gas volume from the hot drying process means an energy saving of 7 %.

Cross-media effects

Increased electricity consumption to feed the dedicated ventilator of the system. Recycling the waste gas modifies the acidity of the fumes and the pipes must be made of stainless steel instead of grey steel.

Technical considerations relevant to applicability

For safety reasons, special attention must be paid to the minimum circulation speed of the recycled waste gas to avoid the accumulation of dust and the risk of fire.

Economics

Recycling part of the waste gas from the dryer requires a high investment since the whole recycling line, including the cyclone, must be heat-insulated. The investment in the insulated

recycling system is about EUR 300 000 (excluding taxes), for a dryer with a capacity of 40 000 l/h.

Driving force from implementation

The related energy savings and reduction of emissions from combustion are the main motivation for using this technique.

Example plants

No information provided.

Reference literature

[157, Copa-Cogeca 2016]

3.4.1.3 Use of waste heat for predrying

Description

The heat of the outlet steam from the high-temperature dryers is used for predrying part or all of the green fodder.

Technical description

A part of the fumes emitted by the dryers, at a temperature of about 120 °C, is directed to a wet scrubber (saturator gas scrubber), after separation in the main cyclones. This wet scrubber washes the steam with water until the dew point and allows the heat emitted by the water condensation to be exchanged with a coolant, normally water, to transport it to the low-temperature dryer. The heated air is applied on a bed of products of about a fifth of a centimetre thick (see Figure 3.16).

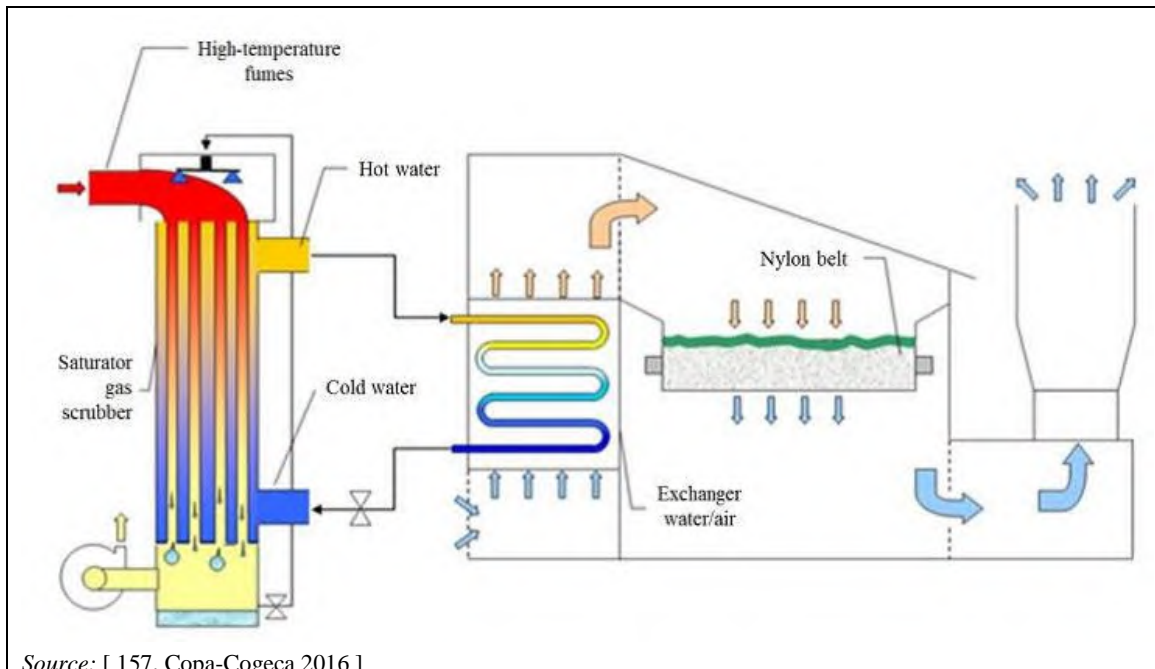

Source: [157, Copa-Cogeca 2016]

Figure 3.16: Implementation of a low-temperature predryer on a dehydration site

Achieved environmental benefits

This technique reduces energy consumption in the high-temperature dryer. Greenhouse gas and other emissions to air are also reduced.

Environmental performance and operational data

This technique applied to fodder with 80 % humidity reduces energy consumption by about 20 % by lowering the humidity rate of the input fodder in the rotary dryer by 5 %.

Cross-media effects

The wet scrubber generates acid washing water, which may require storage before discharge (e.g. landspreading).

Technical considerations relevant to applicability

Generally, there are no technical restrictions to the applicability of this technique in green fodder installations.

Economics

The investment in a predryer is about EUR 5 million for a line evaporating 30 000 litres per hour. Moreover, the high costs for treating the acid waste water must be added to this.

Driving force for implementation

Reduced energy costs.

Example plants

No information provided.

Reference literature

[157, Copa-Cogeca 2016]

3.4.2 Techniques to reduce emissions to air

3.4.2.1 Techniques to reduce dust emissions from green fodder drying

3.4.2.1.1 Cyclone

The technique is generally described in Section 2.3.7.2.3.

Environmental performance and operational data

Cyclones allow dust concentrations from 90 mg to 180 mg/Nm³ depending on the conditions of use. The reduction in emissions of particles achieved is 70 % using this equipment.

Some installation-specific performance data related to the application of cyclones for reduction of dust emissions from green fodder drying are presented in Table 3.5.

Table 3.5: Dust emissions to air from green fodder drying after treatment in a cyclone (dry basis)

Installation ID-point of release	Dust (mg/Nm ³)			O ₂ content (% , mean value)	Monitoring standard	Frequency of monitoring	Additional information
	Min.	Mean	Max.				
264-1	103.7	151.02	193.1	17.50	EN 13284-1	Monthly	Alfalfa. Rotary dryer/mix of coal and lignite. 99 % of particles are PM ₁₀ , 80 % of particles are PM _{2.5} , and 38 % of particles are PM ₁ . 70 % abatement efficiency.
265-1	140	184.25	239	16.40	EN 13284-1	Monthly	Alfalfa. Combined emissions from two lines. Rotary dryer/lignite. Rotary dryer/ mix of coal, lignite and wood. 70 % abatement efficiency.

Source: [193, TWG 2015]

Economics

Investment costs of around EUR 160 000 for a 15 000 l/h dryer and around EUR 250 000 for a 40 000 l/h dryer (values excluding taxes and without heat insulation) have been reported. Additional costs of around EUR 30 000 (excluding taxes) per cyclone must be considered for their heat insulation and connection [157, Copa-Cogeca 2016].

Example plants

Installations #264 and #265 [193, TWG 2015].

Reference literature

[157, Copa-Cogeca 2016], [193, TWG 2015]

3.4.2.1.2 Wet scrubber

The technique is generally described in Section 2.3.7.3.1. This technique is generally used on integrated dehydration sites in sugar refineries.

Environmental performance and operational data

A wet scrubber is applied after a cyclone step in installation #292. An average value of 116.25 mg/Nm³ was achieved for dust emissions (average value of four measurements), and the average O₂ content was 17.45 %. The minimum value was 71 mg/Nm³ (at 16.20 % O₂ content) and the maximum value was 207 mg/Nm³ (at 19.60 % O₂ content). The installation uses a rotary dryer, fuelled with coal.

Reference literature

[193, TWG 2015]

3.4.2.2 Techniques to reduce dust emissions from compound feed manufacturing

3.4.2.2.1 Bag filter

The technique is generally described in Section 2.3.7.2.2.

Environmental performance and operational data

Table 3.6 shows some installation-specific performance data related to the application of bag filters for abating emissions to air from compound feed manufacturing.

Table 3.6: Dust emissions to air from compound feed manufacturing after treatment in a bag filter (dry basis)

Installation ID-point of release	Dust (mg/Nm ³)	O ₂ content (%)	Monitoring standard	Frequency of monitoring	Additional information
246-1	0.05	20.90	EN 13284-1	Once every three years	Pelleting. 67 % cereal, 28 % oilseed as main raw materials.
246-2	0.12	20.90	EN 13284-1	Once every three years	Pelleting. 67 % cereal, 28 % oilseed as main raw materials.
424-2	0.39	NI	EN 13284-1	Biennial	Press cooler. 22 % cereal, 19 % oilseed, 19 % fermentation by-products as main raw materials.
424-5	0.56	NI	EN 13284-1	Biennial	Raw materials preparation. 22 % cereal, 19 % oilseed, 19 % fermentation by-products as main raw materials.
306-9	1.30	20.9	EN 13284-1	Yearly	Raw material preparation. 59 % cereal grains as main raw material.
217-6	1.84	20.9	NI	Yearly	Discharging. 72 % cereal grains as main raw material.
217-2	4.06	20.90	NI	Yearly	Milling process. 72 % cereal grains as main raw material.
308-1	4.20	NI	NI	Yearly	Raw material preparation. 20 % cereal, 47 % oilseed as main raw materials.
217-1	7.08	20.90	NI	Yearly	Milling process. 72 % cereal grains as main raw material.
246-7	18.80	20.90	EN 13284-1	Once every three years	Mill/Grinder. 67 % cereal grains as main raw material.

NB: NI = no information provided.
Source: [193, TWG 2015]

Technical considerations relevant to applicability

This technique may not be applicable to the abatement of sticky dust from pellet cooling.

3.4.2.2.2 Cyclone

The technique is generally described in Section 2.3.7.2.3.

Environmental performance and operational data

Table 3.7 shows some installation-specific performance data related to the application of cyclones for abating emissions to air from compound feed manufacturing.

Table 3.7: Dust emissions to air from compound feed manufacturing after treatment in a cyclone (dry basis)

Installation ID-point of release	Dust (mg/Nm ³)	O ₂ content (%)	Monitoring standard	Frequency of monitoring	Additional information
363-6	0.27	20.90	EN 1328-1	Once every three years	Unloading of raw materials. 65 % cereal, 27 % oilseed as main raw materials.
422-2	0.50	NI	EN 1328-1	Yearly	Cooler exhaust. 22 % cereal, 19 % oilseed, 19% fermentation products as main raw materials.
425-1	1.00	20.90	EN 1328-1	Yearly	Press cooler. 60% cereal, 25% oilseed, 15% mineral as raw materials.
217-4	1.98	20.90	NI	Weekly	Granulate. 72 % cereal, 15 % oilseed as main raw materials.
422-4	2.10	NI	EN 1328-1	Yearly	Cooler exhaust. 22 % cereal, 19 % oilseed, 19 % fermentation products as main raw materials.
308-7	3.40	NI	NI	Yearly	Pellet mill. 20 % cereal, 47 % oilseed as main raw materials.
306-5	3.70	20.90	EN 1328-1	Yearly	Pelleting. 59 % cereal, 27 % oilseed as main raw materials.
NB: NI = no information provided. Source: [193, TWG 2015]					

3.4.2.3 Techniques to reduce odour

3.4.2.3.1 Non-thermal plasma treatment

General information on the technique is given in Section 2.3.7.3.8.

Environmental performance and operational data

In a pet food processing facility (#309), a non-thermal plasma system has been installed for emission volumes ranging from 10 000 m³/h up to 200 000 m³/h. The system has the following main properties:

- cleaning efficiency: 75–95 %;
- modular capacity: 20 000 m³/h;
- power consumption: 10–12 kW per module;
- small equipment footprint and weight for its capacity compared to alternative technologies;
- low pressure drop (approximately 40–180 Pa);
- it can be installed on both the suction side and the pressure side;
- no consumables in operation;
- no effluent release;
- simple on/off operation;
- remote control and monitoring via modem/internet.

The system is cleaned every two weeks during the maintenance shutdown of the factory. The cleaning operation takes six hours (roughly six days/year).

Economics

A total cost of around EUR 700 000 has been reported (cost for five modules to handle 100 000 Ncm/h). Maintenance and operating costs are very low.

Example plants

Used in pet food processing facilities.

Reference literature

[193, TWG 2015]

3.4.2.3.2 Biofilter

General information on the technique is given in Section 2.3.7.3.4.

Environmental performance and operational data

In a UK pet food installation (#416), biofilters using coconut fibres have been applied to retain particles that would normally be emitted into the atmosphere, causing large volumes of odorous gases to spread across the local area, impacting on residents and other receptors. The biofilters are fitted with low air suction to extract air and the air is then passed through the filter which absorbs the odorous particles. With the application of biofilters, a 90 % reduction in complaints about odour has been achieved [193, TWG 2015].

4 BREWING

4.1 General information about the sector

Figure 4.1 and Figure 4.2 depict the beer production and the beer consumption, respectively, in the EU-28 in 2016.

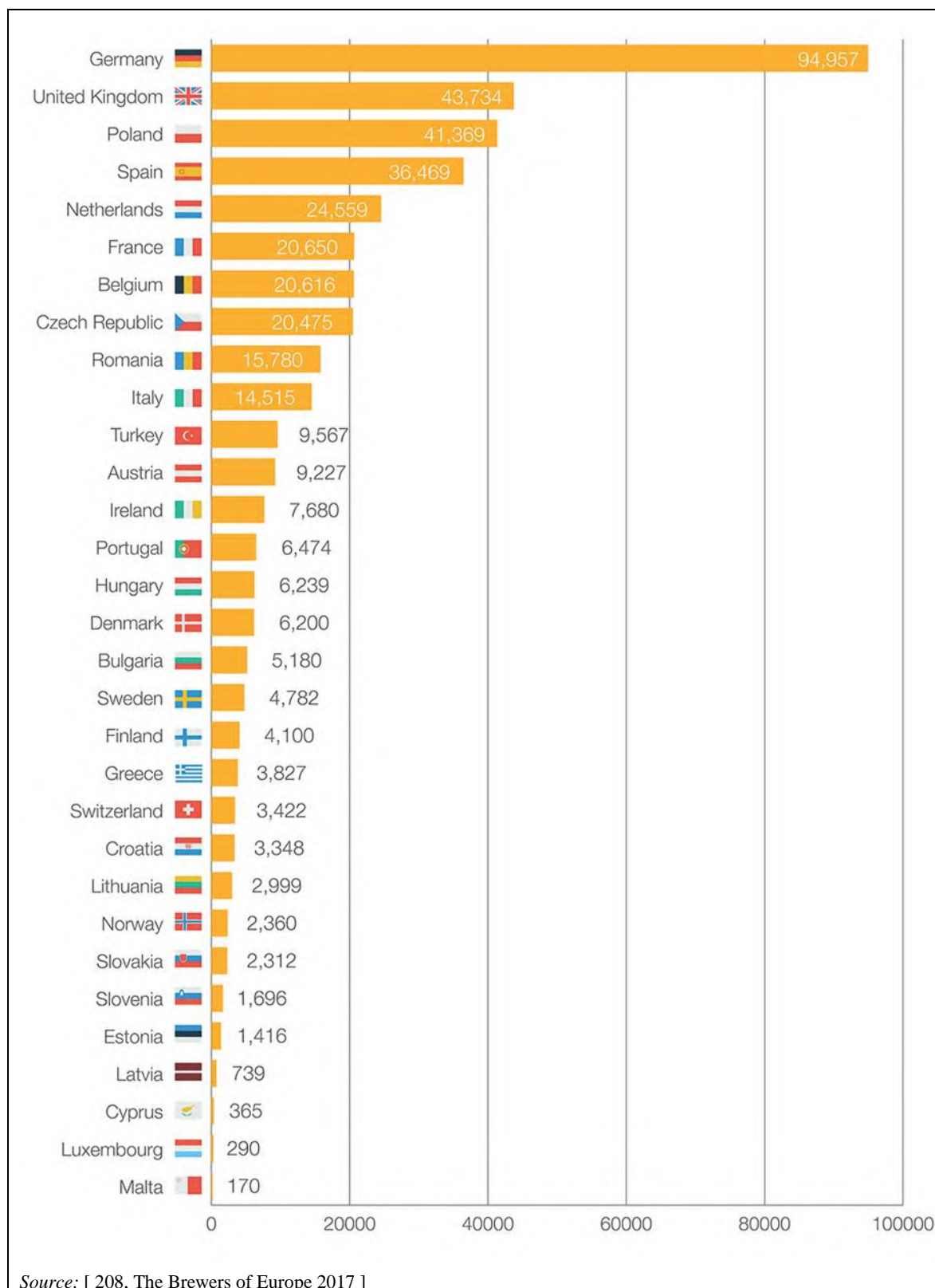

Figure 4.1: Beer production in the EU-28 in 2016 (in 1 000 hl)

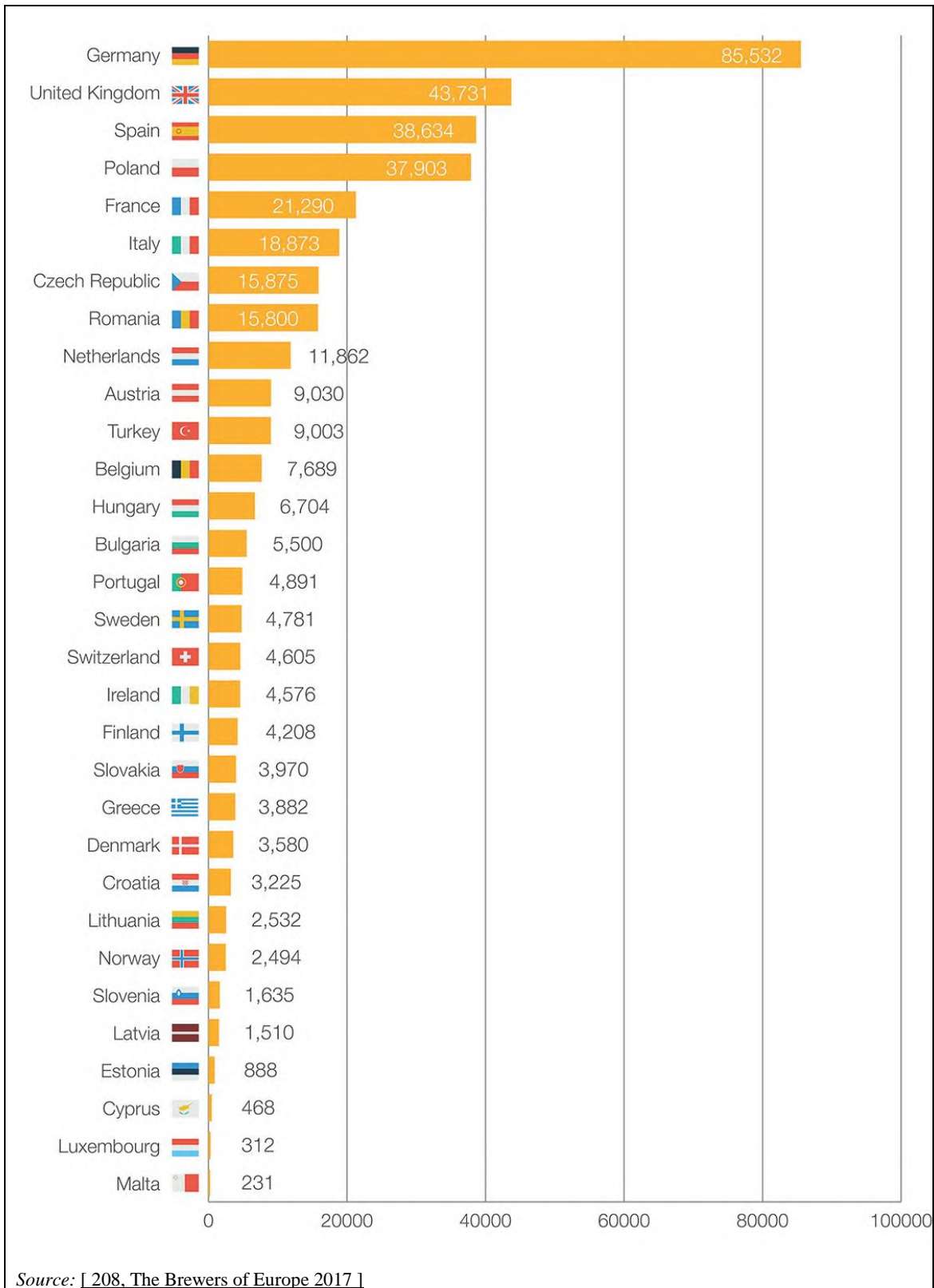

Figure 4.2: Beer consumption in the EU-28 in 2016 (in 1 000 hl)

The number of active breweries in the EU-28 in 2016 is shown in Figure 4.3.

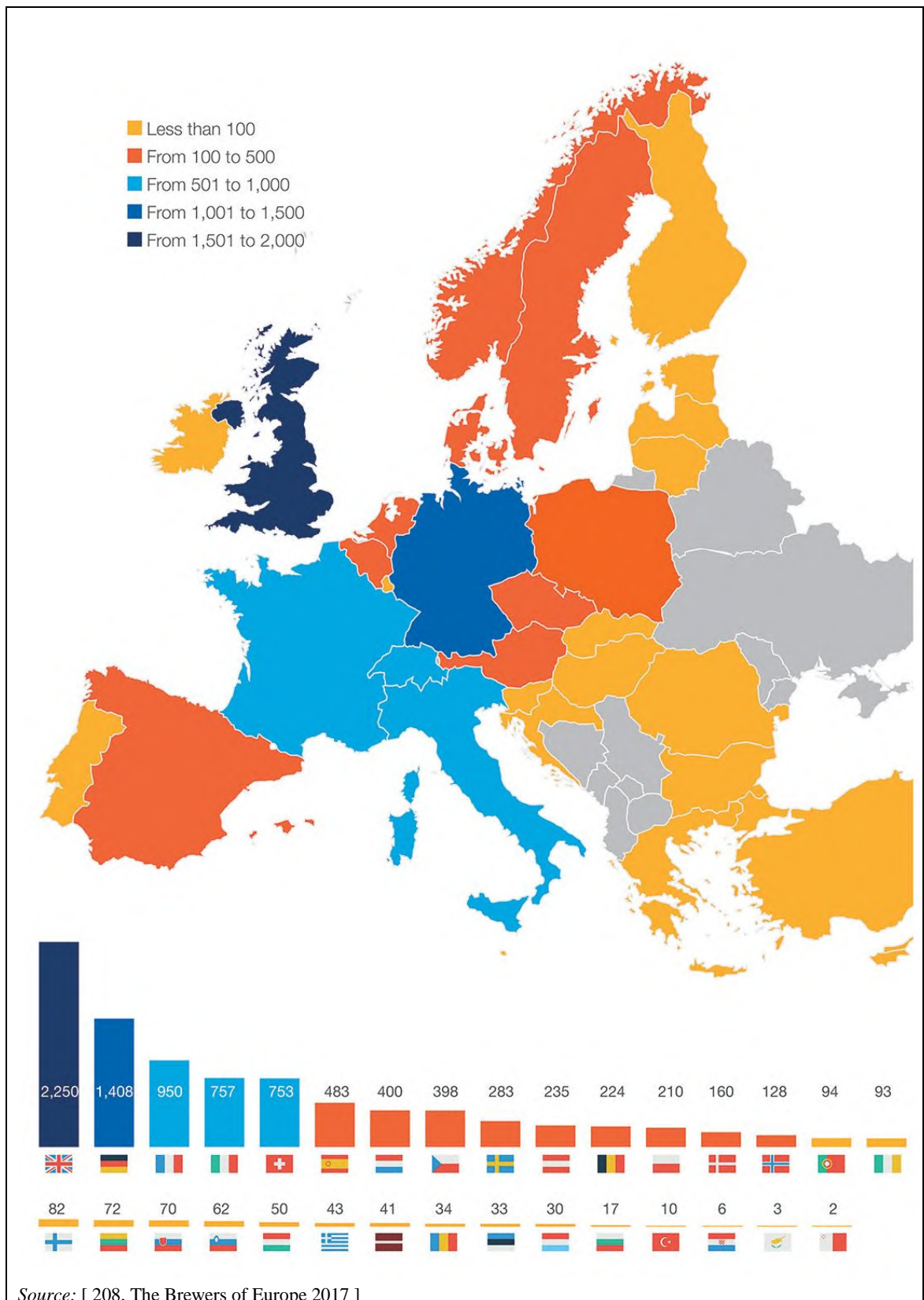

Figure 4.3: Number of active breweries in the EU-28 in 2016

4.2 Applied processes and techniques

Beer is one of the oldest alcoholic drinks in the world. The brewing process is based on a recipe which goes back centuries. Brewing tradition is an important factor in the production of beer, like the Reinheitsgebot in Bavaria adopted in the year 1516 or the beer produced in monasteries.

A general overview of the beer production process is shown in Figure 4.4, e.g. for processing malted barley. In the following sections, individual production steps are described further.

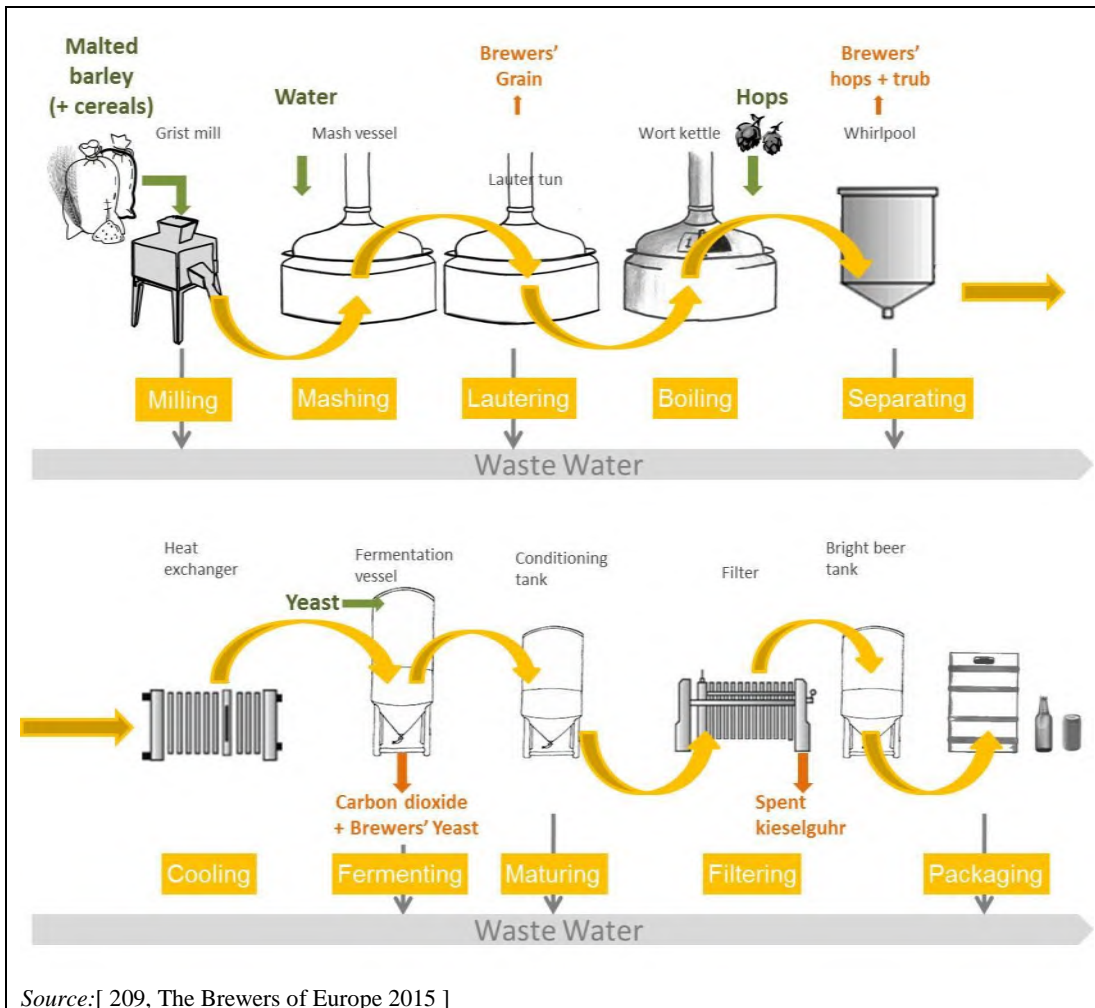

Figure 4.4: Overview of the beer production process

4.2.1 Wort production

4.2.1.1 Overview

The basic ingredient for beer, besides water, is a carbohydrate source like starch. During the brewing process the starch is converted into sugars which are fermented to ethanol (alcohol) and carbon dioxide. The starch sources are generally malted cereals and, depending on the recipe, (unmalted) adjuncts. Malted cereals (e.g. barley malt, sorghum malt) contain natural enzymes which have been formed during the malting process. Adjuncts are starch sources like rice, maize or unmalted barley. The raw materials are delivered to the brewery, weighed, conveyed, cleaned, stored and made available for wort production.

Depending on the location of the brewery, the malt is delivered to the brewery by truck, rail or boat, and is stored in silos with mechanical or pneumatic conveyors. The quantity of malt grains needed for the brew is cleaned (dust and rock removal) and then dry-milled or wet-milled [230, Germany 2013].

After the milling of the malt and preliminary treatment of the adjuncts to facilitate the extraction, the malt and adjuncts (if within the recipe formulation) are mixed with brewing water to form a mash. Adjuncts are a supplementary carbohydrate supply added either to the mash kettle as starch (e.g. maize grits or rice) or alternatively to the wort kettle as sucrose or glucose/maltose syrup. The mash is usually heated following a preset time-temperature programme as described in the recipe, in order to convert and dissolve substances from the malt and the adjuncts in the brewing water.

Extraction is accomplished through a combination of simple dissolution and the activity of naturally present enzymes formed during malting. The substances dissolved in the water are collectively called the extract. The solution of extract and water is called the wort.

When the mashing is completed, the insoluble solids, called the brewers' grains (sometimes referred to as brewers' spent grain), are separated from the wort by straining. Brewers' grains are a valuable co-product. Traditionally, brewers' grains may be used as cattle feed. Alternative uses of the brewers' grains may be as a food ingredient, soil conditioner, or biofuel for heat production. The wort is boiled with hops or hop extracts, releasing bitter substances and oils, which are dissolved in the wort. During boiling, a precipitate consisting mainly of proteins is obtained (the hot trub). After separation of the trub, the finished wort is cooled to approximately 8–20 °C depending on the yeast strain in question and the fermentation process chosen. The cooled wort is hereafter transferred to the fermentation area [209, The Brewers of Europe 2015].

The choice of mashing methods influences the energy consumption in the brewhouse or brewery. Even if, for example, the infusion mashing method consumes less energy than a decoction method, a brewery may not choose the method with lower energy consumption for beer quality reasons and/or in order to maintain the special character of the beer [230, Germany 2013].

The wort production process is depicted in Figure 4.5.

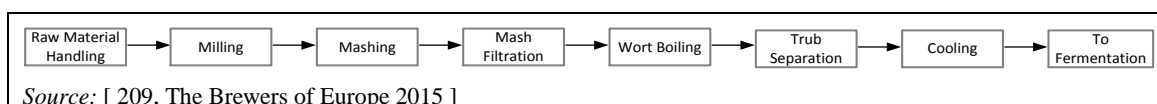

Figure 4.5: Scheme of wort production

4.2.1.2 Raw materials handling

The malt reception essentially handles the cleaning and storage of the required amount of malt. The malt reception department is subdivided into several sections. The first section consists of the unloading of the bulk product, its conveyance and cleaning with subsequent storage in silos. In the second section, the malt is conveyed from the storage silos, cleaned, and, after dry milling, stored in process-specific grist bins. The individual steps involved result in the production of malt fines (dust) due to abrasion, which are expelled and separated in filter systems. Extra machinery usually includes a stone remover and magnets to protect the mills from mechanical damage and dust explosion.

4.2.1.3 Milling

In order to obtain a high yield of extracted substances, the malt is first crushed before being mixed with hot water. Two major types of milling systems are distinguished. These are wet milling, possibly with conditioning, and dry milling which may also comprise conditioning. In the conditioning process, the malt is hydrated by cold or hot water or by steam. As a result, the husks are made more pliable and they are left almost intact. In these processes there will be a consequent use of water and/or energy. When dry milling is applied, the whole grain, including the husk, is crushed. The type of dry milling determines how fine the grits are that are being produced and to what degree the husk is damaged. The dry-milled malt or grist is usually placed in intermediate storage in grist bins before it is added to the mash kettle. In contrast, the grist from wet milling goes directly into the mash kettle. Dry milling may result in a release of dust. This is both a health and explosion hazard [209, *The Brewers of Europe 2015*].

4.2.1.4 Mashing

4.2.1.4.1 Malt mash

The purpose of mashing is to obtain a high yield of extract from the malt grist and adjuncts by extraction in the brewing water. During mashing, the proteins, starches and some other organic materials are broken down by enzymes naturally formed in the grain during malting. The enzymatic reactions require careful control of temperature. This can be achieved by the infusion process through warming of the total mash (most commonly with steam) or a decoction process in which part of the mash is removed, raised to boiling or near-boiling temperatures and returned to the bulk. In both processes the temperature of the wort after mashing and mash filtration is typically approximately 70 °C. The boiling of the mash may give rise to odours.

4.2.1.4.2 Adjunct mash

Adjuncts have usually not been malted and do not contribute significantly to the enzyme activity in the mash. Among others, adjuncts may include maize, rice or unmalted barley. Furthermore, their starch usually has a higher gelatinisation temperature than malt starch. The adjunct is, therefore, mixed with water and cooked separately from the main mash at increased and specific temperatures. The adjunct mash is then mixed with the malt mash and the malt enzymes break down the adjunct starch. In some cases, the addition of special enzymes may be necessary (e.g. endo- β -glucanase or proteases).

4.2.1.5 Mash filtration

During mashing, substances in the malt and adjuncts are broken down and dissolved in the brewing water. In addition to the soluble material (carbohydrates and protein compounds of various complexities), the mash also contains insoluble material (husks). The wort is separated from the brewers' grains by lautering (filtration). This takes place in a lauter tun, mash filter or mash tun. Once the first wort has run off, the remaining brewers' grains are leached out with sparging water to recover more extract.

4.2.1.6 Wort boiling

The wort is heated to boiling point in the wort kettle and the hops are added. The wort is normally boiled for 0.5–1.5 h with 3–8 % evaporation per hour of volume of wort. This has several crucial and beneficial implications for the wort and beer quality. Unwanted (e.g. sulphury) constituents are stripped off, which contributes to the required flavour and taste of the beer. High concentrations of unwanted constituents (e.g. due to lower malt quality) may lead to longer boiling times and consequently higher evaporation rates. Wort boiling may cause emission of odours.

Sucrose and glucose/maltose syrups may also be used as adjuncts. Since no enzymatic breakdown is required, these adjuncts are added to the wort kettle in which dissolution and dispersion are fully achieved.

Energy supply is most commonly by steam but alternatives include thermal oils, pressurised hot water, electricity and burners.

4.2.1.7 Separation and cooling of trub

The wort should be clear and free of particles (hop residues and heat-precipitated proteins, also called trub) before entering the fermentation vessel. The equipment most commonly used for wort clarification is the whirlpool in which the wort and trub particles are injected in a tangential direction. Secondary forces on the particles cause them to migrate and accumulate in a cone at the centre of the bottom of the vessel. Alternatives include a filtration process in a hop back or a decanter centrifuge.

After clarification, the wort is cooled to the pitching temperature. This temperature depends on the type of yeast used and the fermentation process chosen (part of the recipe). Cooling normally takes place in a heat exchanger called the wort cooler. The hot water (75–85 °C) produced is collected and used as brewing water (most likely) or for cleaning for example.

4.2.1.8 High-gravity brewing

It is possible to produce stronger wort than that corresponding to the original gravity of the final beer produced by diluting it, before or normally after fermentation, with carbonated and de-aerated water to the desired extract content. High-gravity brewing is limited by the capabilities of the yeast. Some yeast strains suffer from osmotic stress.

The result is an increase in the brewhouse and cellar capacity. The main benefit, however, is the energy and water saving as the water to be used later in a cold state for dilution does not have to be heated and subsequently cooled with the wort.

4.2.2 Fermentation / Beer processing area

4.2.2.1 Overview

The cold wort is aerated and pitched, meaning that yeast is added, most commonly as a slurry of a defined consistency. Oxygen (air) is necessary to support growth of the yeast to a state and amount capable of fermenting the wort efficiently. The main fermentation is an anaerobic process; the yeast metabolises the fermentable carbohydrates in the wort, forming ethanol and carbon dioxide. A large number of other compounds, such as higher alcohols, esters, aldehydes, organic acids, etc., influences the aroma and taste of the beer.

When the main fermentation is completed and the yeast has been cropped (harvested), the so-called green beer matures most commonly at lower temperatures. At this stage, the yeast reabsorbs certain undesirable constituents of the green beer, the beer is enriched with carbon dioxide, the residual extract is fermented and yeast and other particulates settle out of suspension. However, the fine clarity expected by the consumer from most beer types is still missing. This is achieved by filtering the beer. Kieselguhr is used as a filtration aid in most cases. Also, soluble substances like proteins, which can cause visible particles in a later stage, are removed in a beer stabilisation process. The filtered and stabilised beer is pumped to the bright beer tanks [209, The Brewers of Europe 2015].

Figure 4.6 depicts a general overview of the fermentation and beer processing steps.

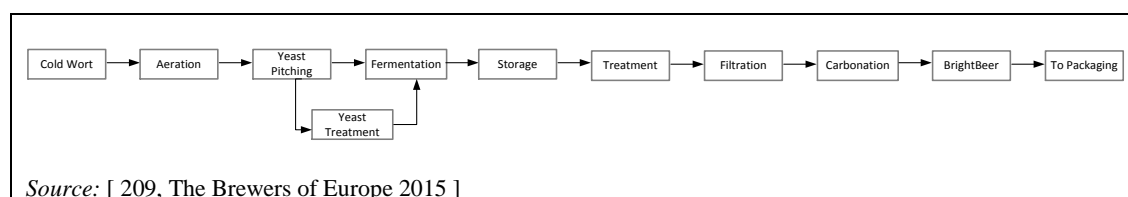
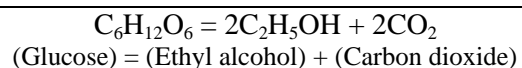

Figure 4.6: Scheme of fermentation / Beer processing

4.2.2.2 Fermentation

The breakdown of simple sugars into alcohol is normally referred to as alcoholic fermentation. Yeasts, usually *Saccharomyces sp.*, e.g. *cerevisiae* or *bayanus*, are used to produce ethanol from carbohydrates and very small amounts of other organic compounds. This conversion can be represented by the following equation:



The temperature of fermentation is usually in the range of 8 °C to 30 °C as fixed in the recipe. The temperature and yeast strain affect the rate of fermentation, the efficiency of conversion and the flavour and the aroma of the finished product. The pH may also be adjusted. Carefully selected strains of yeasts are often used to optimise the alcohol yield and the production of aromatics as secondary components. Amines, vitamins and trace elements can be added as yeast nutrients.

In the early stages of fermentation, there is separation of the cold break, consisting mainly of protein formed during the cooling of the wort. The separation is often performed by simple sedimentation in the fermentation vessel, but may also be achieved by flotation, centrifugation or filtration.

During the subsequent pitching phase, sterile air or O₂ is injected into the clarified wort and the yeast is added. Aeration is used to ensure that the yeast is supplied with an adequate amount of

oxygen in order to support cell multiplication. Later on, the metabolism of the yeast changes from respiration to anaerobic alcoholic fermentation; it then converts the carbohydrate molecules contained in the wort to produce ethanol, carbon dioxide and, to a lesser extent, other compounds that affect the character and quality of the beer.

Fermentation processes are exothermic biochemical reactions and so heat is generated. To maintain the desired fermentation temperature, the fermentation tanks are cooled. Refrigerants used for indirect cooling (secondary refrigeration) are alcohol/water, glycol/water, ice-water or brine. The refrigerant for direct cooling (primary refrigeration) is usually ammonia.

Fermentation usually takes place in horizontal tanks or vertical cylindro-conical tanks, which may be installed indoors or outdoors. The CO₂ produced during the fermentation process may be collected by a CO₂ recovery system. This will be reusable in the beer, brewing process or other products like carbonated soft drinks.

Once fermentation has taken place, the yeast is cropped (or harvested) and pumped to the yeast storage tanks. During the fermentation, yeast is produced in excess. A part of this yeast is reused for a new batch of wort, the remainder being treated as a co-product or disposed of. The production yeast may be reused several times, but should be replaced due to decreasing vitality and viability.

The vessels have to be cleaned after each fermentation to remove the soil in them. Carbon dioxide needs to be displaced from the vessel or it will react with caustic detergents, reducing efficiency (acid detergents are an alternative). Prior to use, the fermenter vessel and associated process equipment need to be disinfected.

4.2.2.3 Yeast handling

The yeast treatment starts with yeast propagation, i.e. production of fresh yeast. This yeast is used for pitching of the wort. The yeast is cooled and can be cleaned using a yeast sieve (optional) or using acid washing. The yeast is stored cold.

The surplus yeast from fermentation or tank sediment from storage is sold to companies for further processing or may be used as animal feed, or for pharmaceuticals, or as flavouring. Beer (or alcohol) may be recovered from surplus yeast by filtration, centrifugation, sedimentation or distillation.

4.2.2.4 Maturation and storage

After fermentation, further processes are required to produce commercial-quality beer. Further (secondary) fermentation (maturation) is required to remove certain off-flavours and to improve the quality of the product. Cold storage is usually then employed. This causes precipitation of particles that would otherwise form slowly in the packaging and cause the consumer to receive cloudy beer. Maturation is mostly performed at temperatures lower than those applied in the primary fermentation. The product is rapidly put into cold storage, below 0 °C (enabled by the anti-freeze effect of alcohol and other solutes), and is usually regarded as requiring at least three days of storage.

A clarification and stabilisation effect by enhanced precipitation may be caused by the use of finings (e.g. isinglass or woodchips). Fining is the process of clarifying liquids, i.e. removing suspended particles which give the liquid a cloudy appearance. The fining agent introduced causes the minute haze particles to flocculate and precipitate out of the solution. These particles are proteins, polyosides, polyphenols, ferrous or cupreous complexes. For the fining action to take place, the electrical charges between the fining agent and the particles should be opposed, which means that it is necessary to carefully choose the fining agent depending on the effect sought. The nature and the dose of the fining agent can be determined by laboratory tests.

The fining agents used can be divided into two major groups; organic and mineral fining agents. Some organic fining agents are isinglass collagen, egg albumin and tannins. Some mineral fining agents are bentonites and silica gel.

The beer may be chilled prior to filtration (also known as secondary cooling).

4.2.2.5 Filtration and stabilisation

The purpose of the filtration is to obtain a specified level of clarity; the purpose of stabilisation is to enhance shelf life. Commonly used filter aids are kieselguhr (diatomaceous earth), perlite or cellulose. Filtration often takes place in a kieselguhr filter using various systems such as frame, candle or mesh filters. Different grades of kieselguhr are used: coarse-graded kieselguhr as a precoat to start building the filter cake on the support layer of the filter; to prevent clogging of the filter and to achieve extended filter runs, fine-graded kieselguhr is continuously dosed into the unfiltered beer as body feed, thereby constantly building up the depth of the filter cake.

Methods to filter beer without kieselguhr are becoming more widespread. The use of kieselguhr-free filter aids (e.g. polymer-based filter aids, cellulose, perlites) and membrane filtration are possible.

In most cases, filtration is accompanied by stabilisation. Stabilisation is used to selectively remove beer colloids by means of adsorption, e.g. using silica gel and/or PVPP (polyvinylpyrrolidone), in order to counteract the beer's tendency to become turbid after filling. Other possibilities to stabilise are ion exchange, tannic acid or enzymatic stabilisation. Another possibility (in the case of PVPP stabilisation) is to install an additional regenerative PVPP filter system in combination with the kieselguhr filtration. Regeneration reduces the wastage of PVPP powder, although equipment, energy and hot caustic for regeneration are required.

To act as a polishing filter after the kieselguhr filter, a cartridge filter or sheet filter may be installed. For polishing and sterilising filtration, several filter systems, e.g. sheet filters, module filters, cartridge filters and membrane filters, may be used. As an alternative to the sterile filter, the beer may be thermally treated (flash or tunnel pasteurisation) to increase its microbiological stability.

Spent kieselguhr may be recycled, used in building materials, applied in agriculture as soil improver or fertiliser, recycled by heat treatment by a third party, or else disposed of.

4.2.3 Beer packaging and storage

For general information about packing and filling see Section 2.1.4.1.

4.2.3.1 Overview

From the bright beer tanks, the beer is pumped to the packaging area where most beer is bottled, canned or kegged.

During this final operation, it is important that:

- the beer is prevented from coming into contact with oxygen to protect the fresh taste of beer;
- no carbon dioxide is lost as the beer is carbonated to certain specifications during its processing;
- microbiological contamination of the product is prevented; this may require treatment and disinfection of the water;
- the packaging is marked to obey local legal requirements concerning traceability and other laws, e.g. concerning customer information.

Packaging lines may be equipped quite differently, not only with respect to packaging material but also with respect to the level of automation and inspection. Typically, consumption of energy, compressed air, cleaning chemicals and water and the machinery requirements are very significant. Returnable bottles require thorough cleaning. The bottle washer consumes large quantities of energy, water and caustic. Furthermore, substantial quantities of waste water are discharged. The use of non-returnable packaging material reduces the consumption of energy, water and caustic on site, therefore reducing waste water generation.

In packaging lines using non-returnable bottles and cans, the bottles/cans are only flushed with water before filling. Alternatively, compressed air is used to blow out any solid particles. The glass in non-returnable bottles is readily recyclable if the regional infrastructure is in place. If kegs are used, they are cleaned and sterilised with steam before filling.

Packaging lines can be noisy, in particular those for glass bottles and kegs. In some cases, the brewery surroundings may mean that careful soundproofing of the packaging block is required.

4.2.3.2 Returnable bottles

Figure 4.7 shows a typical returnable bottles line. The individual steps are described below.

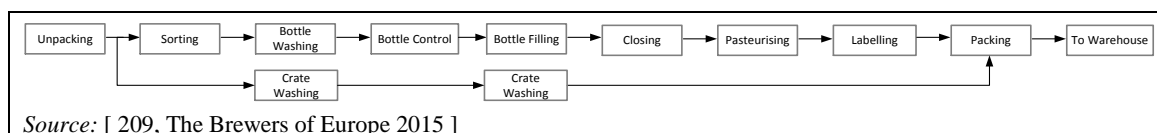

Figure 4.7: Scheme of returnable bottles line

Before being filled with beer, the returned bottles are conveyed to a bottle washer which cleans the bottles both inside and out. Impurities may be present inside the bottle, including residual beer, moulds, insects, cigarette butts, organic solvents, etc. Outside impurities may include labels, aluminium foil and dust particles.

Bottle washing consists of soaking in caustic solution, rinsing, sterilisation and re-rinsing. To improve the cleaning effect, surfactants, sequestrants and similar agents are added to the cleaning solution. In order to guarantee the hygienic condition of the bottles, disinfectants may be added in the rinsing zones of the bottle-cleaning machine.

In addition to filling bottles, the most important function of the filling machine is to prevent oxygen coming into contact with the beer. The bottles are emptied and counter-pressurised with CO₂ (usually twice) before the actual filling with beer. Bottles are generally reusable 20–30 times and so there will be some degradation (scuffing), but failed bottles may be recycled.

If the beer has not been sterile-filtered, the beer may be pasteurised to prolong shelf life. Pasteurisation guarantees practically unlimited biological stability. Two different methods are used for the pasteurisation:

- tunnel pasteurisation, during which the beer is pasteurised in bottles (or cans);
- flash pasteurisation, employing a heat exchanger in which the beer is pasteurised before it is poured into bottles (or kegs).

The bottles are packed in crates, cartons or other forms of transport packaging and palletised. Plastic crates are reused and cardboard is recyclable. The crates are washed with water and inspected for damage, colour runs, abraded logos, and so on. Sound and correct crates are sent to the packaging machine.

4.2.3.3 Non-returnable bottles

A typical non-returnable bottles line is depicted in Figure 4.8.

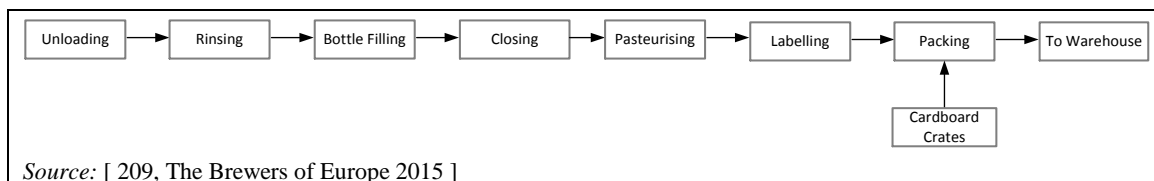

Figure 4.8: Scheme of non-returnable bottles line

For packaging lines using non-returnable bottles, the steps are the same as described for the returnable bottles as from the filling of the bottles onwards. However, the first steps are different for non-returnable bottles as the bottles are not delivered in crates.

Non-returnable bottles are delivered on pallets from the glassworks. The bottles are pushed off the pallets in layers onto a reception table / conveyor chain. When a layer has been deposited, the spacer packaging is removed and returned to the manufacturer.

The bottles arrive clean from the glassworks but dust may have contaminated the bottles during transport or storage. Therefore, the bottles are rinsed before filling, either by spraying with water or the solids are blown out with compressed air. For rinsing, the bottles are turned so that their openings face downwards and they are then turned upright again before filling.

4.2.3.4 Cans

Cans are non-reusable, although recycling rates may be high depending on the facilities in the region. Recycling the metal saves energy by reducing the need for mining and extracting the aluminium or steel. A typical canning packaging line is presented in Figure 4.9.

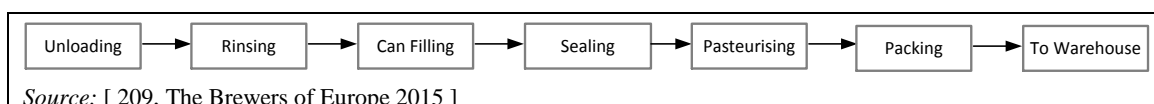

Figure 4.9: Scheme of canning line

Cans are supplied in bulk in tall packs. The cans are pushed off the pallet in layers onto a conveyor chain. When a layer has been deposited, the spacer packaging is removed and returned to the manufacturer. The cans generally arrive clean from the manufacturer, but dust may have contaminated the cans during transport or storage. Therefore the cans are rinsed before filling, either by spraying with water or the solids are blown out with compressed air. For rinsing, the cans are turned so that their openings face downwards and they are then turned the right way up again before filling.

The cans are sealed with lids immediately after filling and the filling height is checked. Sealing of cans is a two-step operation (pressing first with a pre-roller and secondly with a seaming roller) that needs to be performed exactly right to prevent pressure loss and thus beer spoilage. The cans may then be pasteurised. The cans are packaged into various types of pack including cardboard (recyclable) and plastic.

4.2.3.5 Kegs

A typical keggling packaging line is shown in Figure 4.10.

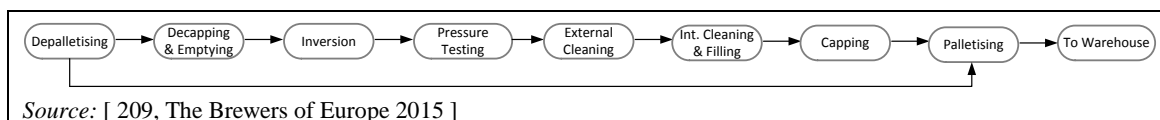

Figure 4.10: Scheme of keggling line

Steps in the cleaning of returned kegs comprise pre-soaking, cleaning and rinsing the outside of the keg. The cleaning solution is recirculated. Internal cleaning and filling of kegs is performed in several stages in one or more filling aisles. First, the kegs are internally cleaned with water and caustic and sterilised with steam. Afterwards, the kegs are pressurised and filled with flash - pasteurised beer. Weighing of the kegs controls the filling volume. The keg head is rinsed and capped.

4.2.3.6 Plastic bottles

As an alternative to single-use and refillable glass bottles, different solutions in the form of plastic bottles have emerged. Materials like PET are available to be used in beer packaging. Different filling lines for plastic bottles are used compared to glass bottles, with specific transportation for the empties, or blow-moulding machines if the bottles are to be produced on site. Blow-moulding requires a substantial amount of energy.

For non-refillable PET bottles, recycling systems are available which may include bottle-to-bottle recycling. More often, recycling to non-food-grade applications is applied such as for straps and carpets.

4.2.3.7 Warehouse storage

Packed beer is stored in the warehouse. It is important to store bottled beer inside as sunlight affects the beer quality, causing an unpleasant sunstruck flavour. Bottles are also protected against artificial light. Warehouses for glass bottles situated in a cold climate should be heated in order to prevent possible bottle breakage due to freezing.

4.2.4 Non-alcoholic beer production

The legal definitions of alcohol-free beer vary from country to country. For instance, this type of beer contains a maximum alcohol level of 0.5 % in England, Germany and the Netherlands; 1 vol-% in Spain; and no detectable amount, i.e. less than 0.05 wt-%, in the US. The alcohol concentration of ≤ 0.05 wt-% is below the usual analytical detection limits.

There are several methods applicable for the production of non-alcoholic beers. These methods can be divided into four main categories: fermentation-free brewing, dilution, alcohol removal/dealcoholisation, and restricted alcohol fermentation. These methods are described in the following sections [211, Rezaei et al. 2010].

4.2.4.1 Fermentation-free brewing

In fermentation-free brewing, no yeast is added to the wort. In other words, the fermentation stage is eliminated. However, the expected sensory characteristics of the final product are improved by using different additives. Achieving a microbalance among beer components, especially flavour compounds, is difficult and will result in a beer that has an attractive flavour. Nevertheless, the method is easier to perform and more economical than other non-alcoholic production techniques.

4.2.4.2 Dilution

In this method, wort is initially produced with a dry matter content of several times more than the expected concentration. After separation of the yeast cells, dilution is carried out using pure potable water (demineralised and deoxygenised) up to the determined solids and alcohol concentration. The pH is then adjusted by adding organic acids (such as lactic acid). This is followed by a carbonation stage. This procedure takes advantage of the reduced fermentation time and a higher available capacity of the fermenter. The dilution procedure can also be accomplished by using chilled carbonated water. The dilution method can also be performed by blending the dealcoholised beer with normal beer.

4.2.4.3 Alcohol removal (dealcoholisation)

Alcohol removal (dealcoholisation) is a process in which the alcohol produced during the fermentation is removed from the beer by different methods in accordance with the standards of low-alcohol or alcohol-free beer. The alcohol removal process can include heat- and membrane-based processes, as described below.

4.2.4.3.1 Vacuum distillation

Vacuum distillation consists of two stages: evaporation under high vacuum (vacuum evaporation) and then cold condensation (e.g. 38–48 °C / 0.06–0.1 bar). This practice is also known as low-temperature/low-pressure distillation. Dealcoholisation can also be performed by distillation of the beer under vacuum, in which an ordinary beer, previously pasteurised, is degassed at a pressure of about 1 bar (with recovery of the foam and the flavour compounds) and then dealcoholised by means of a vacuum evaporator (0.05–0.12 bar), at a temperature between 30 °C and 50 °C.

The method generally suffers from the limitations that it also removes (to some extent) other volatile components such as flavour and fragrance compounds and dissolved gases such as carbon dioxide and sulphur dioxide, which are important for sensory characteristics, controlling the acidity of the beverage and for their bacteriostatic effects on beer-spoiling microorganisms.

4.2.4.3.2 Water vapour / Gas stripping under vacuum

Stripping is a practice in which water vapour or a neutral gas (nitrogen or carbon dioxide) is passed through the wort under vacuum in order to strip ethanol from the bulk. This method is also called gaseous entrainment or the alcohol desorption method. At the end of fermentation, sudden stripping of the carbon dioxide that is produced during fermentation leads to the removal of alcohol from the beer. This is why a high pressure difference between the inside of the reactor and outside environment (about 1 bar) is required.

4.2.4.3.3 Dialysis

This process operates at low temperature and uses the selectivity of a semi-permeable membrane. Small molecules pass through the membrane into the dialysis medium. The medium flows to a vacuum distillation column, where the alcohol is continuously removed, and the stream of alcohol-free dialysis liquor returned to the dialysis unit. The final product may contain as little as 0.5 % alcohol.

4.2.4.3.4 Reverse osmosis

In this method, fermented wort is passed through a semi-permeable membrane under high-pressure conditions. The membrane is permeable to water, ethanol and other small molecules. Large molecules including flavour agents are rejected and remain in the concentrated beer. Production of non-alcoholic beer with an alcohol content < 0.5 vol-% is possible with reverse osmosis. Addition of water is recommended for facilitating the removal of ethanol. In order to retain heat-sensitive substances and to increase the rejection coefficient of volatile compounds, the temperature should be low (about 5 °C).

However, dealcoholisation of beverages by reverse osmosis removes not only volatile low molecular weight components such as water, alcohol, flavour and fragrance components, and dissolved gases such as carbon dioxide and sulphur dioxide, but it may also remove certain low molecular weight, non-volatile, non-ionic solutes such as organic acids and simple sugars. Moreover, the common practice involves dilution of the reverse osmosis concentrate or retentate with pure water to replace the water that is removed by the permeate. This will result in some changes in quality parameters such as flavour, fragrance, colour, acidity and stability. Restoration of these depleted components takes place by their readdition to the concentrate in proper proportions to produce a high-quality product.

4.2.4.4 Restricted alcohol fermentation

Restricted fermentation is a method in which the production of alcohol during the production process is reduced in the early stages of fermentation. This is achieved either by using yeast that can only partially ferment the wort or by repressing or interrupting fermentation by applying different compositional and/or process procedures (interrupted fermentation technique). In other words, the restricted fermentation methodology consists of using yeasts under conditions in which they are not physiologically capable of producing an alcoholic fermentation but can excrete metabolites that help to impart a beer-like taste to the solution.

Restricted fermentation processing can be classified into two subclasses, namely suspended batch and continuous immobilised processes. In the batch-type process, yeast cells are in a suspended state in the wort during the fermentation. In this procedure, it is difficult to keep the process parameters such as temperature and concentration of dissolved oxygen at precisely the desired values (at equilibrium). A minor deviation from the desired values may result in the formation of alcohol at a higher level than that allowed in the final product (e.g. 0.05 %). In the production of alcohol-free beer, immobilisation of yeast cells has also been practised. The immobilisation technique with the microporous sintered-glass system has been successfully employed for the production of alcohol-free beer. This method provides the advantages of high controllability, flexibility, and a high biomass concentration and allows short contact times compared to the batch method. As an alternative procedure in this practice, firstly, beer with a certain amount of alcohol is produced in a short time. Then, after 2–4 hours of flavour ageing, dilution of the beer is carried out with cooled carbonated water to achieve the desired alcohol content.

4.2.5 Cleaning and disinfection

Brewing and fermentation are batch processes. The equipment has to be cleaned and often disinfected after each use. The equipment in the brewing department is generally cleaned with caustic and rinsed. The equipment in the fermentation area is generally rinsed, cleaned with caustic, rinsed, cleaned with acid, disinfected and rinsed. Cleaning requires substantial amounts of water, chemicals and energy. In general, the cleaning is affected by the four factors of the Sinner's circle (see Section 2.1.3.2.2).

These factors are determined, to some extent, by the design of the cleaning machine. Other quantities such as the type and concentration of the chemicals, additives and surfactants used are optimised in cooperation with the chemicals supplier.

Within the bottling department, the bottle-cleaning machine is the biggest consumer of fresh water, and therefore also the source of most of the waste water. A reduction in water consumption can be achieved by a combination of different methods for the different zones of the cleaning machine.

This cleaning process, which takes place primarily in the soaking zone and the caustic bath, results in clean germ-free bottles. The interaction of chemical, thermal and mechanical effects ensures that the bottles are cleaned within a certain time.

The bottles pass through the individual zones of the bottle-cleaning machine in the order shown in Figure 4.11.

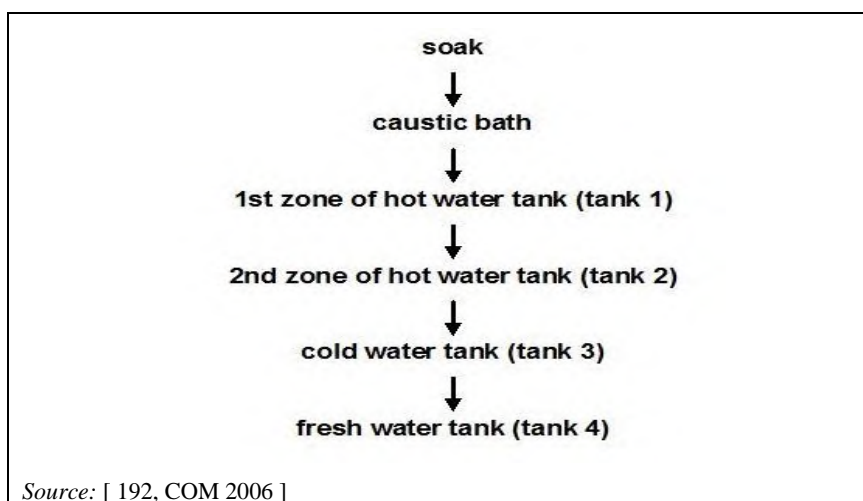

Figure 4.11: Bottle cleaning and rinsing steps

In the caustic bath, the glass bottles are cleaned using approximately 2 % caustic soda solution at around 80 °C. The alkali, chemicals and small dirt particles remaining in the bottles leaving the caustic bath then have to be washed away during the subsequent cleaning zones. The dirt particles entrained from the caustic bath can be rinsed off in the first spray zones. It is considerably more difficult to remove any alkalinity carried into the first hot water zone (tank 1) with the bottles. As the bottles leave the main bath, they are still wet with this cleaning solution, resulting in liquor entrainment [35, Germany 2002].

The pH of the first basin after the main caustic bath is originally between 10 and 11. This high pH favours deposition of lime and magnesium salts, i.e. removal of scale, when hard drinking water is used. Neutralisation of the water may reduce scaling considerably.

Moreover, to save caustic soda and fresh water and to avoid unnecessary waste water loads, the contents of the bottle-cleaning bath are settled and filtered at the end of the production period. The cleaning solution is pumped from the bottle-cleaning equipment to a sedimentation tank using electrical energy. This tank also serves as a temporary storage unit. The settled particles are drawn off with a filtration unit that also requires the input of electrical energy for pumping. The water is then available again to be used for cleaning at the beginning of the next production period [35, Germany 2002].

4.3 Current consumption and emission levels

4.3.1 Energy consumption

Energy is supplied to breweries in the form of oil, gas, coal, steam, hot water and electricity. Heat is normally distributed in the brewery as steam or hot water. The actual heat consumption of a brewery depends on the process and production characteristics such as the packaging type (returnable or one-way), pasteurising technique, type of equipment, and extent of by-product treatment. The main heat-consuming processes in a brewery are: mashing, wort boiling, CIP/disinfection, bottle and keg washing, pasteurising and room heating (in cold climates) [72, *Brewers Europe 2002*]. The largest single heat consumer will normally be the wort kettle. Heat consumption for some departments/processes is given in Table 4.1.

Table 4.1: Heat consumption for different brewery departments/processes

Department/ Process	Minimum	Mean	Maximum	Literature ⁽¹⁾	Measured ⁽²⁾
	Figure			Range	
	(MJ/hl beer)			(MJ/hl beer)	
Brewhouse	87	92	121	84–113	50–80
Bottling installation	58	86	94	25–46	38–58
Kegging installation	8	11	13	8–13	NI
Process water	3	4	8	4–8	NI
Service water	NI	NI	NI	8–17	NI
Miscellaneous	NI	NI	NI	33–46	95
Total	156	193	236	162–243	183–233
	(kWh/hl beer)			(kWh/hl beer)	
Brewhouse	24.17	25.56	33.61	23.33–31.39	13.89–22.22
Bottling installation	16.11	23.89	26.11	6.94–12.78	10.56–16.11
Kegging installation	2.22	3.06	3.61	2.22–3.61	NI
Process water	0.83	1.11	2.22	1.11–2.22	NI
Service water	NI	NI	NI	2.22–4.72	NI
Miscellaneous	NI	NI	NI	9.17–12.78	26.39
Total	43.33	53.62	65.55	44.99–67.50	24.44–64.72
⁽¹⁾ 20 000 to 500 000 hl beer sold/yr.					
⁽²⁾ 300 000 to 500 000 hl beer sold/yr.					
NB: NI = no information provided.					
Source: [35, <i>Germany 2002</i>]					

The main single consumers of electricity in a brewery are: packaging area, cooling plant, compressed air plant, CO₂ recovery plant, waste water treatment plant and air conditioning. There are also many small consumers of electricity, accounting for a large part of the electricity consumption, e.g. pumps, ventilators, drives and electric lighting [72, *Brewers Europe 2002*].

Bottles and cans are normally manufactured off site. A new trend is the PET bottle which can be produced on site from preforms in a PET blowing machine. The manufacture of PET bottles on site can contribute considerably to the overall energy consumption [37, *The Brewers of Europe 2017*].

Figure 4.12 shows data on overall specific energy consumption in breweries (MWh/hl of products) reported by various brewing installations. Among the energy efficiency techniques reported, wort vapour condensers, boiler economiser, heat recovery in various stages of the process and use of vacuum pumps are mentioned.

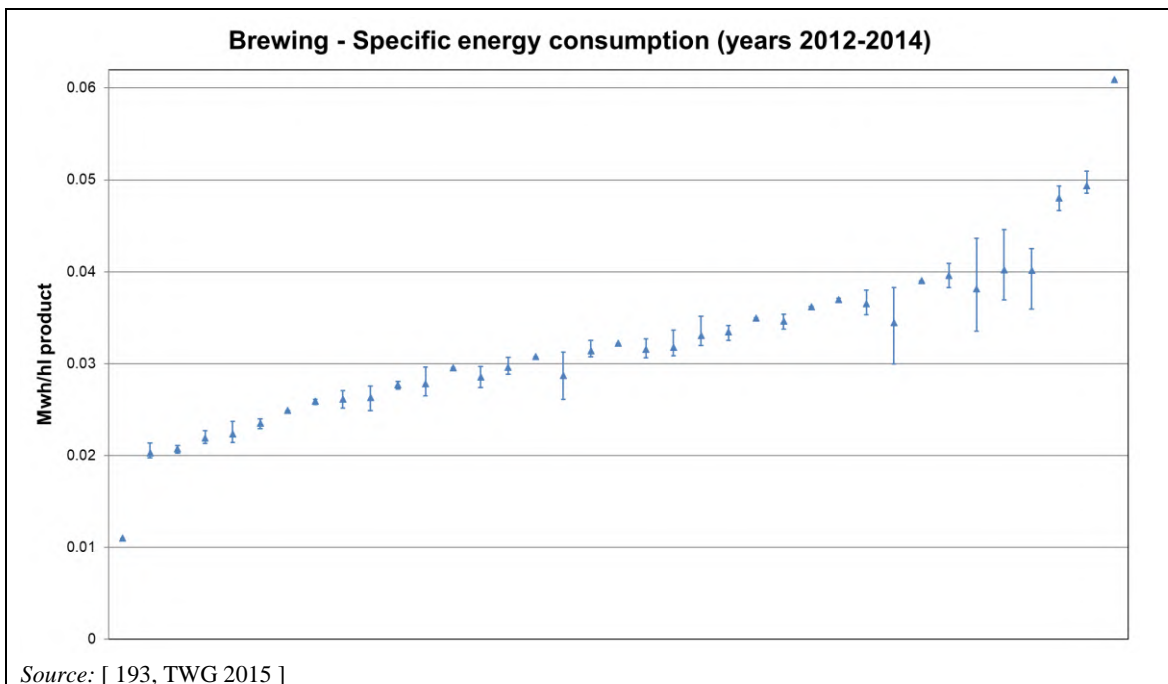

Figure 4.12: Specific energy consumption (MWh/hl of products) in brewing

4.3.2 Water consumption

Figure 4.13 shows data on specific water consumption (m^3/hl of products) reported by various brewing installations. Most of the reported specific water consumption values are below $0.6 \text{ m}^3/\text{hl}$ of products. The reported rate of water recycling varies between 1 % and 23 %.

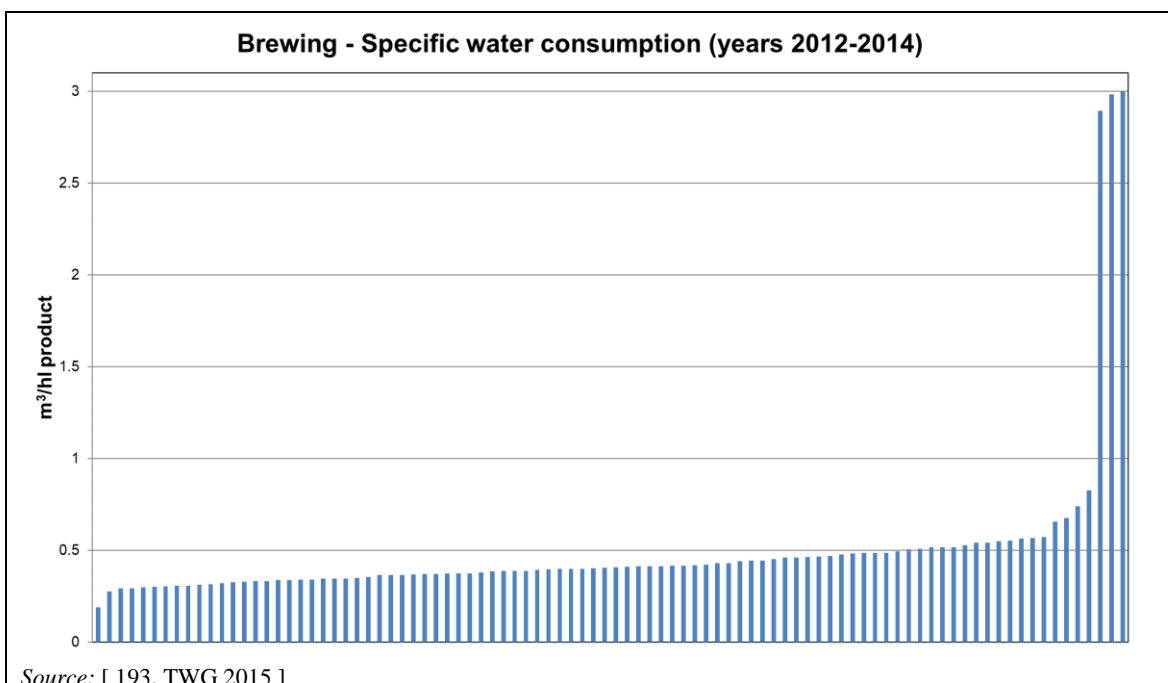

Figure 4.13: Specific water consumption (m^3/hl of products) in brewing

The water consumption figure varies depending on the type of beer, the number of beer brands, the size of brews, the existence of a bottle washer, how the beer is packaged and pasteurised, the age of the installation and the system used for cleaning. If brackish or hard water is used, the

water may require treatment before use, during which losses of up to 30 % may occur. Bottling consumes more water than kegging. Consumption levels are high for once-through cooling systems and/or losses due to evaporation in hot climates.

The largest water-consuming processes are [72, Brewers Europe 2002]:

- mashing and sparging;
- cleaning of packaging material (e.g. bottle washing);
- pasteurisation (tunnel);
- rinsing and cleaning of process equipment (CIP);
- cleaning of floors;
- soap lubrication of conveyors in the packaging area;
- flushing and vacuum pump for filler;
- keg washing;
- cooling water.

4.3.3 Solid output

Solid materials enter the brewery in the form of raw and ancillary materials. Solid materials leave the brewery as co-products such as brewers’ grains and surplus yeast, primary and secondary packaging materials, and other solid waste. Generally, only a very small amount of hazardous waste is produced, e.g. spent laboratory chemicals and batteries. Major solid output fractions are identified in the example shown in Figure 4.14. The example installation produces beer bottled mainly in returnable bottles, and uses plastic crates. Waste water treatment residues such as sludge are not considered.

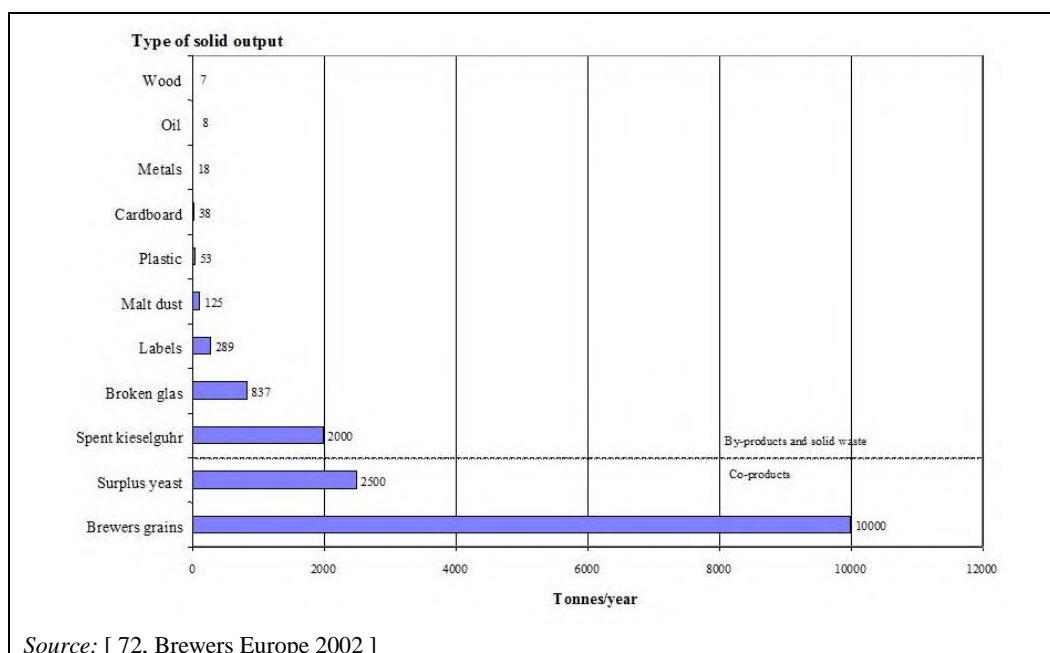

Figure 4.14: Co-product, by-product and solid waste quantities from a brewery producing 1 million hl beer/yr

Husk and malt grits may be mixed into brewers’ grains. Surplus yeast, brewers’ grains, trub from the whirlpool and husk and malt grits may be used as animal feed. Surplus yeast is also used in cosmetics, pharmaceuticals and spreads. Spent kieselguhr can be used in the cement industry and broken glass may be reused for glass manufacturing. Label pulp from cleaning the returnable bottles, and cardboard and paper waste may be reused in the paper industry. Plastics and metal from hop cans and replacement equipment may be recycled.

4.3.4 Emissions to water

Usually, there are fluctuations in the generation of waste water as brewing takes place in batches. The peak flow can be in the order of 2.5–3.5 times the average flow, depending on how close to the production area the measurement is carried out. The period of peak flow is normally short. Peak flows occur in the brewhouse and beer processing area in connection with cleaning operations. In the packaging area, peak flows occur during the closing down of the line as bottle washers and tunnel pasteurisers are emptied. A third area where large peaks can occur is in the water treatment during the backwash of sand filters.

The concentration of organic material will depend on the waste water to beer ratio and the discharge of organic material into the WWTP. Production of non-alcoholic beer may result in high loads if the condensed alcohol is discharged into the WWTP. Normally, the process waste water has a low content of non-biodegradable components. Brewery waste water usually has a COD/BOD ratio of 1.5–1.7, indicating that the waste water is easily biodegradable.

The waste water discharge is equal to the water supply minus the water content in produced beer, the evaporated water in the brewery and utility plants, and the water present in the by-products and solid waste.

Table 4.2 shows waste water production in different brewing departments/processes.

Table 4.2: Waste water production in different brewery departments/processes

Department/Process	Specific waste water volume (m ³ /hl beer produced)			
	Measured		Literature	
	From	To	From	To
Brewhouse/cold storage	0.03	0.06	0.01	0.11
Fermentation cellar	0.01	0.02	-	0.07
Storage cellar	0.01	0.01	-	0.09
Filtering cellar	0.02	0.06	0.01	0.09
Bottling cellar	0.04	0.07	0.01	0.28
Cask cellar	0.01	0.04	0.01	0.07
Miscellaneous	0.02	0.20	-	-
Total process ⁽¹⁾	0.32	0.51	0.25	0.60
⁽¹⁾ Not all waste water streams are listed in the table, which explains the difference with the total sum. Source: [102, Heidemann et al. 1993]				

The waste water flow is variable and the pollution load of the different steps do not follow the volume's throughput, e.g. bottle cleaning produces a high amount of waste water but with only a low organic load, while waste water from fermentation and filtration accounts for only about 3 % of the total waste water volume but 97 % of the BOD load [74, World Bank (IBRD) et al. 1998]. Organic pollution in waste water mainly comes from the following sources:

- brewers' grains;
- yeast and surplus yeast;
- trub discharge;
- weak wort discharge;
- emptying and rinsing of brewhouse kettles, process tanks and fermenters;
- pre- and after-runs from diatomaceous earth filtration;
- chase water from process pipes;
- bottle washer;
- beer losses in the packaging area during filling and bottle breakage;
- conveyor lubrication.

TSS in the waste water originate mainly from the discharge of by-products and possible label pulp from the bottle washer. Nitrogen originates mainly from yeast, trub, brewers' grains losses, and detergents used for tank cleaning. Phosphorus may come from the cleaning agents used. Large variations in pH may occur due to the use of acids and caustic for the cleaning of process equipment and returnable bottles, and to the regeneration of ion exchangers for water treatment. Heavy metals are normally present in very low concentrations. Wear of the machines, especially conveyors in packaging lines, may be sources of nickel and chromium.

Figure 4.15 shows reported data on specific waste water discharges (m^3/hl of products) from brewing installations and all types of discharges. More information on emissions to water can be found in Section 2.2.3.

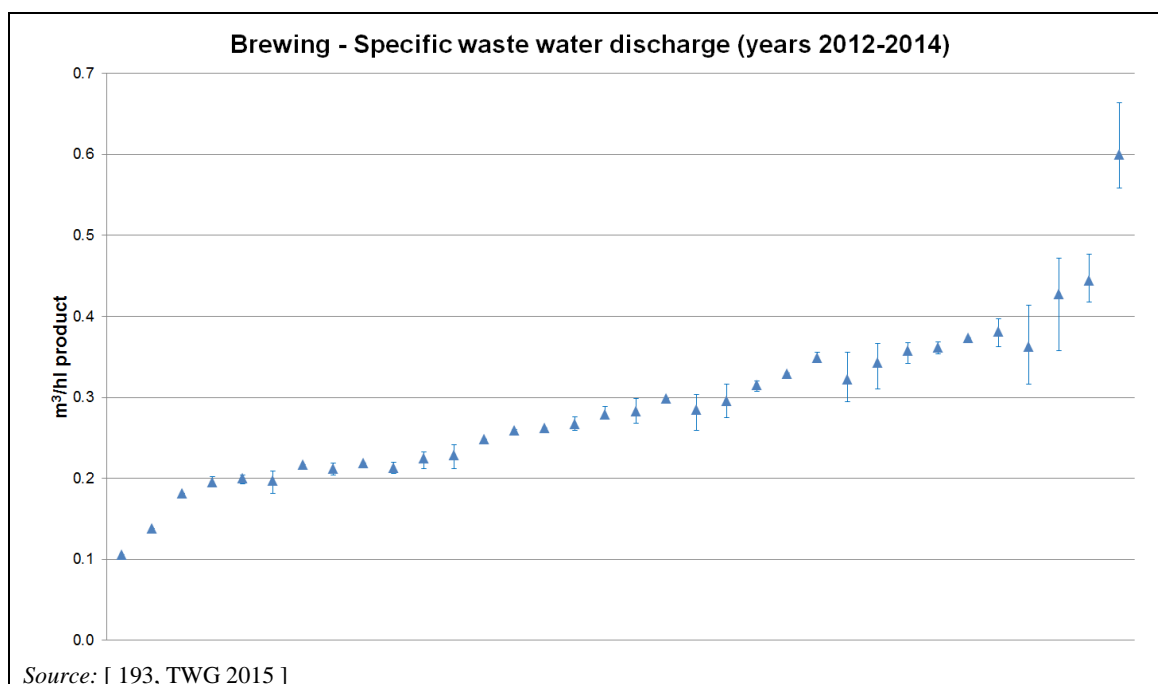

Figure 4.15: Specific waste water discharge (m^3/hl of products) in brewing for all types of discharges

4.3.5 Emissions to air

Apart from the emissions to air from the energy generation processes, the main potential emission source is dust from the intake and transport of raw materials, i.e. malt grains and grits. Ammonia from cooling operations may be accidentally released. Odour may arise from the boiling of wort.

4.3.5.1 Dust emissions

Dust is mainly generated during the raw material intake, transport and processing. However, as the dust emission from these systems is normally limited by the integration of cyclones and bag filters, the emission is generally very restricted, with a dust emission load below 100 g/h from a single point of release [193, TWG 2015]. Some powdered raw materials like wheat flour or starch have a small particle size and may be retained to a lesser extent by cyclones and bag filters.

A general overview of the data received for dust emissions to air from the brewing process is shown in Figure 4.16 (lower values) and Figure 4.17 (higher values). The applied end-of-pipe abatement techniques are also indicated.

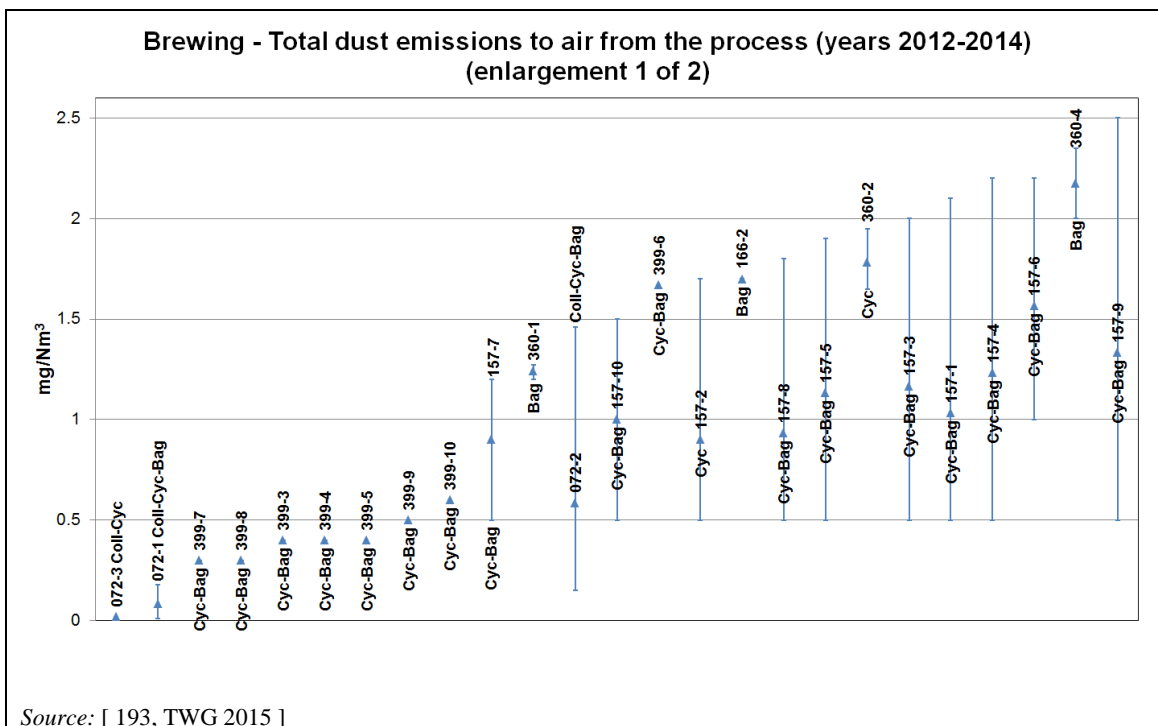

Source: [193, TWG 2015]

Figure 4.16: Total dust emissions to air from the brewing process (1 of 2)

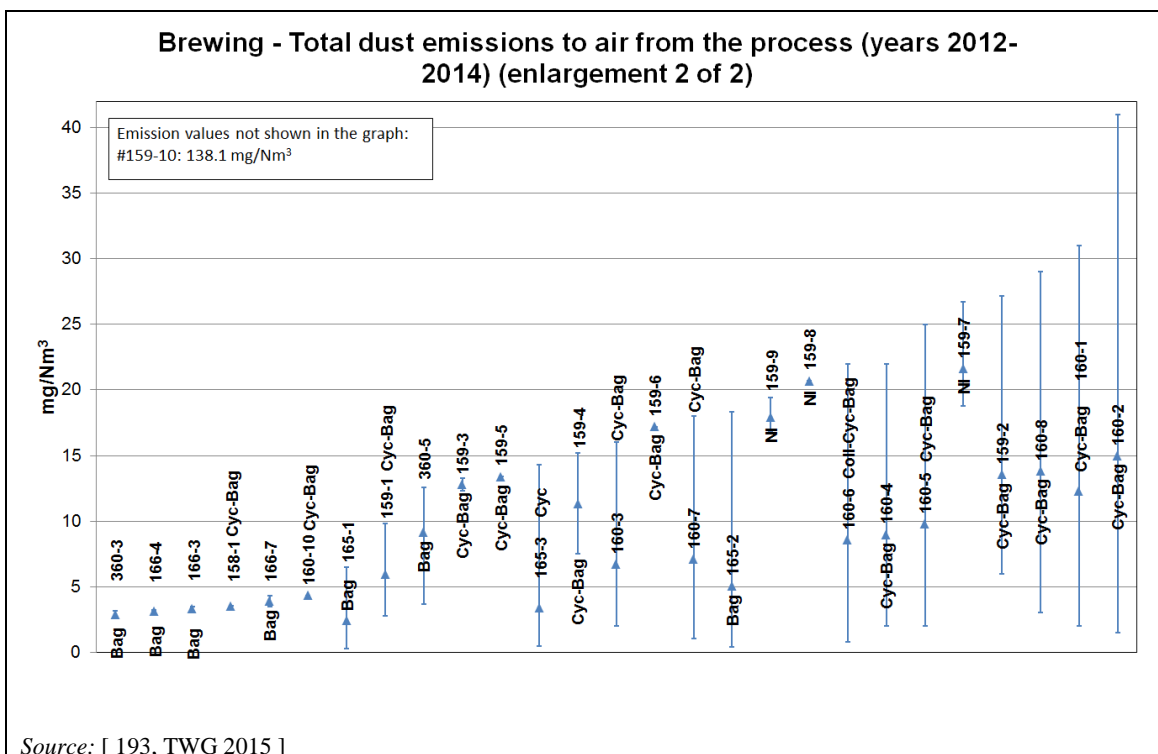

Source: [193, TWG 2015]

Figure 4.17: Total dust emissions to air from the brewing process (2 of 2)

The meaning of the symbols and abbreviations used in Figure 4.16 and Figure 4.17 are indicated in Table 3.3 and Table 3.4.

4.3.5.2 Odour

The largest source of odour emissions is the evaporation of volatile organic compounds derived from wort boiling. Recovering heat from wort kettles saves energy by condensing approximately 95 % of the vapour. This also reduces odour emissions because condensable odorous vapours are removed from the exhaust air. The vapour emissions occur for a short period of typically 3 to 5 minutes at the beginning and at the end of each production batch [212, The Brewers of Europe 2015].

Other odour sources are waste water treatment, storage and handling of co-products (surplus yeast) and by-products (spent kieselguhr), oil storage, ventilation of beer cellars and packaging lines and emissions to air from the boiler house.

4.4 Techniques to consider in the determination of BAT

4.4.1 Techniques to increase energy efficiency

4.4.1.1 Mash infusion process

Description

Mash infusion process carried out instead of mash decoction process.

Technical description

Milled malt is fed, together with warm brewing water, into the mash tun. This mash is heated to a temperature of 78 °C and is stirred constantly. The mash infusion process is carried out entirely in the mash tun. This process is an alternative to the decoction process where the thick part of the mash is separated and boiled in a dedicated mash kettle, i.e. heated to 100 °C.

Achieved environmental benefits

Reduced air pollution, e.g. odour, and lower energy consumption compared with the mash decoction process.

Environmental performance and operational data

The mash infusion process does not need to boil part of the mash, as is required in the mash decoction process. This results in energy savings of between 20 % and 50 %.

Table 4.3 shows the energy consumption in the brewhouse of a large brewery in Germany which uses a mash infusion process.

Table 4.3: Energy consumption in the brewhouse of a large brewery with a mash infusion process

Consumer	Electrical energy		Heat energy			
	Total (kWh)	Specific (kWh/hl)	Total (10 ⁶ kWh)	Specific (kWh/hl)	Total (10 ⁶ MJ)	Specific (MJ/hl)
Brewhouse wort preparation	675 500	0.84	8.2	10.2	29.52	36.6
Total consumption	6 520 730	8.1	22.82	28.3	82.152	101.9

Source: [192, COM 2006]

In addition, the mash infusion process reportedly has lower odour emission levels than the decoction process.

Cross-media effects

Less heat will be used which means that less fuel has to be burnt to produce steam or hot water. This reduces CO₂ and other combustion-associated emissions.

Technical considerations relevant to applicability

Mash infusion is applicable in the processing of full malt beers. The mash infusion method traditionally requires high-quality malt, though the malt grades available permit the use of a mash infusion process for many beer types. However, the type of mashing process has an effect on beer taste and aroma, and is part of the beer recipe, which could limit changeover.

Economics

No additional costs compared with the mash decoction process.

Driving force for implementation

The mash infusion process is primarily used because of its lower energy consumption, because it requires less equipment and is easier to automate, compared with the mash decoction process.

Example plant

A large brewery in Germany.

Reference literature

[3, The Brewers of Europe 2018], [35, Germany 2002], [72, Brewers Europe 2002], [122, Brewers Europe 2004], [192, COM 2006]

4.4.1.2 Mashing-in at higher temperatures

Description

The mashing-in of the grain is carried out at temperatures of approximately 60 °C, which reduces the use of cold water.

Technical description

Typical mashing-in takes place at 37 °C or 50–52 °C, heating to 60–62 °C and mashing off at 78 °C. Quality improvements have been achieved for malt used for mashing. One of the implications of these improvements is that the need to keep the temperature constant at for example 50 °C has diminished, and some breweries have demonstrated that they are routinely able to mash in at 60 °C. The consequence for the energy balance is that larger volumes of hot water from the wort cooling need to be blended with smaller volumes of cold water.

Achieved environmental benefits

Reduced energy consumption.

Environmental performance and operational data

The exact heat energy saving achieved by mashing in at 60 °C rather than 50 °C for example varies, but in most brewhouses a higher mashing-in temperature will imply that hot water from the wort cooling only needs to be blended with smaller volumes of cold water to produce 60 °C mashing-in water.

The hot water can be generated from recovered heat, or has to be produced by using steam from burning fuel. This is crucial is to ensure a proper hot water balance.

Cross-media effects

No information provided.

Technical considerations relevant to applicability

The technique may not be applicable due to the product specifications, e.g. wheat beers need to be mashed in at lower temperatures (45 °C to 55 °C). Brewers monitor the potential risks at increased mashing-in temperatures. Insufficient degrading of protein- and beta-glucan during mashing-in is the most important risk, but it is possible to overcome this by supply of malt of a consistently high quality, i.e. with sufficient amounts of natural enzymes. The adjuncts used also play a role in the choice of mashing-in temperature.

The supply of high-quality malt may be restricted as the quality of the crop varies from year to year. Also, the brewing water may require mashing-in at 30–53 °C (phytase) to lower the pH of the mash [98, TWG 2017]. The mashing-in temperatures are part of the beer recipe, and therefore the scope of changes can be limited.

Economics

No information provided.

Driving force for implementation

Energy savings and related cost reduction.

Example plants

Some breweries in Nordic countries [3, The Brewers of Europe 2018].

Reference literature

[3, The Brewers of Europe 2018], [30, TWG 2018], [98, TWG 2017], [169, Nordic Council of Ministers 2011]

4.4.1.3 Heat recovery from wort kettle vapour

See also Section 2.3.2.1.1.

Description

Recovery of the heat from the boiling wort vapour (e.g. by plate heat exchangers).

Technical description

There are energy conservation systems designed to recover the heat arising from vapour from the boiling wort, as this vapour may generate heat when condensed. An example of such a vapour condensation plant is shown in Figure 4.18.

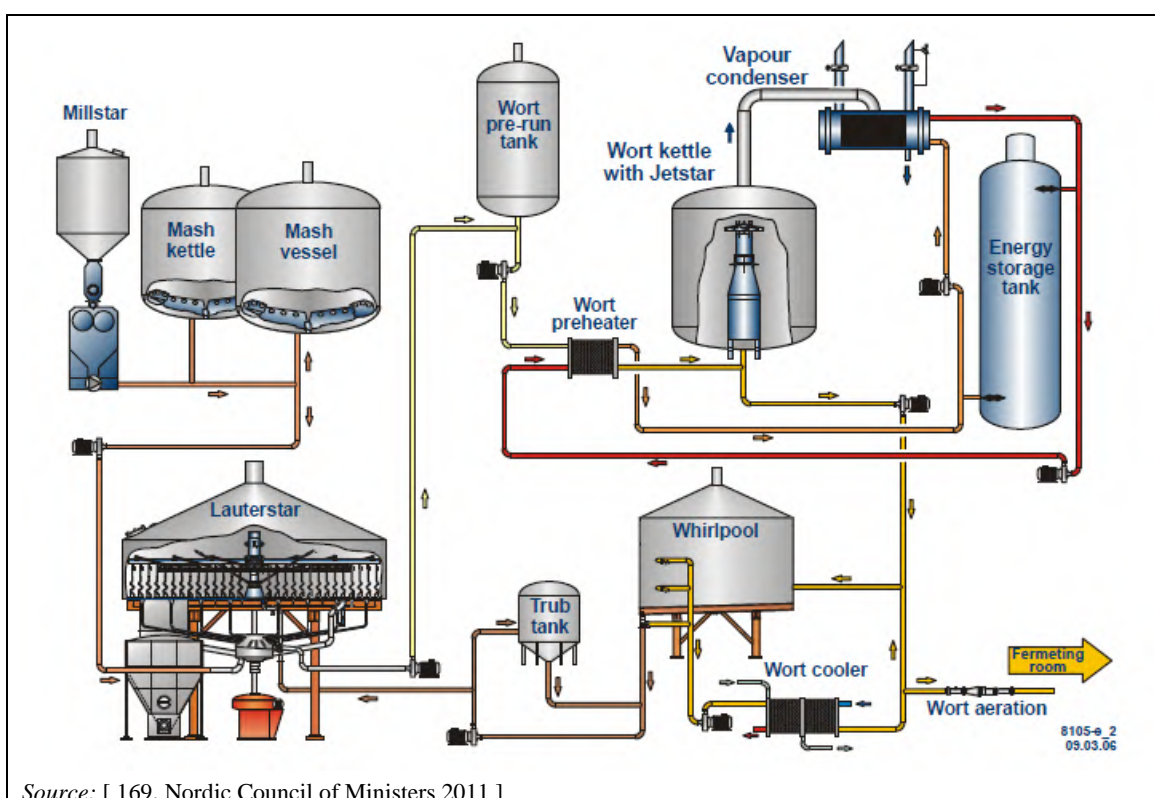

Figure 4.18: Energy recovery from vapour condensation

Achieved environmental benefits

Reduced thermal energy consumption. Reduction of odour emissions.

Environmental performance and operational data

Such vapour condensation systems are able to recover approximately 75 % of the condensation heat. The roughly 25 % remaining gets lost in transfers, when boiled-off vapour is released to the open air at times during the process and via heat losses.

Cross-media effects

Less heat will be used which means that less fuel has to be burnt to produce steam or hot water. This reduces CO₂ and other combustion-associated emissions.

Technical considerations relevant to applicability

The technique is generally applicable and has limited effect on beer quality.

Economics

The energy saving in the brewhouse is approximately 26 %, or approximately 13 % of the total heat consumption [3, The Brewers of Europe 2018].

Driving force for implementation

Energy savings and related cost reduction.

Example plants

At least one example plant in Spain and several plants in Germany [3, The Brewers of Europe 2018].

Reference literature

[3, The Brewers of Europe 2018], [169, Nordic Council of Ministers 2011]

4.4.1.4 Increase of the degree of high-gravity brewing

Description

Production of concentrated wort which reduces its volume and thereby saves energy.

Technical description

It is possible to produce a stronger wort than that corresponding to the original gravity of the final beer by diluting it, before or mostly after fermentation, with carbonated and de-aerated water to the desired extract content. This process is referred to as high-gravity brewing (HGB).

Breweries can apply HGB at a rate of 20–30 %. This implies that a finished pilsner of 10 % Plato is brewed at an original gravity of 12–13 % Plato.

Achieved environmental benefits

Reduced energy consumption.

Environmental performance and operational data

An increased degree of HGB provides proportional heating energy savings, i.e. a HGB degree of 25 % will result in 25 % heat energy savings in the wort kettle and 25 % cooling energy savings at fermentation.

Cross-media effects

Less heat will be used which means that less fuel has to be burnt to produce steam or hot water. This reduces CO₂ and other combustion-associated emissions.

Technical considerations relevant to applicability

The technique may not be applicable due to the product specifications. The disadvantages of high-gravity brewing are a lower foam stability and a variety of stress effects on the yeast. The different behaviour of the yeast can cause problems with the beer flavour.

Economics

No information provided.

Driving force for implementation

HGB provides a quick way of increasing capacity as less fermenters are needed. Savings will be achieved due to the smaller wort volume to boil and due to the smaller fermenting beer volume to cool.

Example plants

Various plants in Spain.

Reference literature

[3, The Brewers of Europe 2018], [169, Nordic Council of Ministers 2011]

4.4.1.5 Integrated energy system in the CO₂ recovery plant**Description**

Integrated energy system in the CO₂ recovery plant which allows the exchange of energy from heating and cooling processes.

Technical description

In the first option for this technique, an evaporator captures the cooling energy arising from evaporation of CO₂, which cools down relatively warm glycol returning from glycol evaporators at points of use elsewhere in the brewery. This option has the ability to reuse the cooling energy from evaporation which in classic CO₂ recovery plants would get lost.

The second option for this technique is able to work in conjunction with with the brewery's existing NH₃ cooling system (CO₂-NH₃). Heat coming from the recovery system is cooled by the brewery's NH₃ cooling system. In this way two energy streams are linked: heat released when liquefying CO₂ gas and heat taken up when evaporating liquid CO₂. This system simultaneously facilitates the liquefaction of incoming CO₂ gas (from the fermenters) and vaporisation of liquid CO₂ (from the storage tanks).

Achieved environmental benefits

Reduction of energy consumption for cooling.

Environmental performance and operational data

The amount of total energy saved is approximately 85 kWh per 1 000 kg of CO₂ evaporated.

Cross-media effects

Energy consumption for running the heat exchanger, in the event that an intermediate cooling medium (glycol) is used (< 1 % extra electricity consumption compared to the saving).

Technical considerations relevant to applicability

The CO₂ recovery plant needs considerable re-engineering and investment to realise the modification to energy optimisation. It may not be applicable to breweries that do not liquefy CO₂ prior to use in the brewery. Also, the cooling energy produced from the vaporised CO₂ must be able to be utilised elsewhere in the brewery (first option). The technology is applicable to breweries able to process approximately 500 kg CO₂/h and run continuously, i.e. > 5 000 h/year [3, The Brewers of Europe 2018].

Economics

The electrical energy and maintenance costs are relatively low. An installation cost of EUR 30 000 and a payback period of 11 months have been reported [169, Nordic Council of Ministers 2011].

Driving force for implementation

Energy savings and related cost reduction.

Example plants

Various plants in Spain.

Reference literature

[3, The Brewers of Europe 2018], [169, Nordic Council of Ministers 2011]

4.4.1.6 Decrease of evaporation rate during wort boiling

Description

The evaporation rate can be reduced from 10 % down to approximately 4 % per hour (e.g. by two-phase boiling systems, dynamic low-pressure boiling).

Technical description

Evaporation rates have gradually come down from 10 % per hour to 6–7 % per hour in most breweries. Latest tests at breweries have demonstrated that the needed evaporation rate is possibly lower, and some breweries have documented that a 4 % evaporation rate is sufficient. Brewers frequently monitor the potential quality risks at reduced evaporation rates. Unwanted sulphur components in the wort and cloudy finished beer are two well-known risks. By decreasing the evaporation rate, thermal energy is saved proportionally.

Achieved environmental benefits

Reduced energy consumption.

Environmental performance and operational data

A reduced evaporation rate will lead to proportional savings of heat energy. If the evaporation rate is reduced from 10 % to 6 %, a 40 % heat energy saving is expected. If the brewery wants to reduce the evaporation rate from 6 % to 4 %, it should for each brew be able to control the evaporation rate +/- 0.3 %, whereas this margin at 6 % evaporation may be +/- 0.6 %.

Cross-media effects

Less heat will be used which means that less fuel has to be burnt to produce steam or hot water. This reduces CO₂ and other combustion-associated emissions.

Technical considerations relevant to applicability

The technique may not be applicable due to the product specifications. Evaporation of the wort is, among other things, meant to strip out unwanted flavours like DMS which may limit the lower evaporation rate.

Economics

No information provided.

Driving force for implementation

Energy savings and related cost reduction.

Example plants

Various plants in Spain.

Reference literature

[169, Nordic Council of Ministers 2011]

4.4.1.7 Mixer in fermentation tank

Description

Introduction of forced mixing in fermentation tanks.

Technical description

The introduction of forced mixing in fermentation tanks by use of rotary jet mixers reduces the processing and cooling time. The fermentation capacity is hereby increased and a reduction of the operating costs is achieved.

The system consists of a rotary jet mixer and a circulation pump, which force a better mixing in the fermentation tank.

Achieved environmental benefits

A shorter operation time reduces the demand for cooling energy due to less heat ingress through the tank insulation.

Environmental performance and operational data

A combination of the rotary jet mixer system with external cooling via a heat exchanger make it possible to redesign the fermentation tank and to avoid cooling zones in the tank. The fermentation tank should be well insulated. Processing and cooling times can be reduced by up to 30 %.

If using the rotary jet mixer system alone, no changes in the cooling energy are expected. A higher yield of alcohol may be gained; however, this affects the taste and body of the beer (less sugars).

Cross-media effects

Extra electricity consumption is needed to operate the rotary jet mixer by a pump, the heat input of which also has to be compensated by extra cooling.

Technical considerations relevant to applicability

Generally applicable.

Economics

For a 2 million hl/yr brewery introducing jet mixer technology requires an investment of less than 30 % of the cost of installing new fermenters, equal to a saving of more than EUR 2 million. Using the combined mixer and external cooling system will save costs for cooling energy, processing time and make fermentation tanks much cheaper.

Driving force for implementation

Increased productivity and potential cost savings.

Example plants

Implemented in Denmark and the UK [3, The Brewers of Europe 2018].

Reference literature

[3, The Brewers of Europe 2018], [169, Nordic Council of Ministers 2011]

4.4.2 Techniques to reduce water consumption

See also Section 2.3.3.1.1.

4.4.2.1 Reuse of hot water from wort cooling**Description**

Hot water recovered from wort cooling is stored in insulated water tanks and used for various processes, e.g. for use in production, cleaning operations, flushing brew kettles or for room heating.

Technical description

Hot water is normally produced in a heat exchanger when cooling down the wort from 100 °C to the fermentation temperature, e.g. about 10 °C. The hot water is stored in insulated water tanks and used for various processes, e.g. for use in production, cleaning operations, flushing brew kettles or for room heating.

Achieved environmental benefits

Reduced energy consumption. Reduced water consumption and improvements in the hot water balance of the operation.

Environmental performance and operational data

It is reported that if hot water is used for mashing only, there will be an excess of hot water, resulting in an overflow from the hot water tank. Large amounts of water and energy can be lost due to this overflow. To optimise the hot water system, a hot water balance can be made for the entire brewery. When, where and how much hot water is used should carefully be investigated. The investigation should also reveal if it is possible to use hot water instead of cold water heated by steam for functions such as CIP, sterilisation and bottle cleaning. It is also important that the hot water tank is sized correctly to avoid the brewery producing hot water from steam after a weekend stop in the brewhouse.

Cross-media effects

Less heat will be used which means that less fuel has to be burnt to produce steam or hot water. This reduces CO₂ and other combustion-associated emissions.

Technical considerations relevant to applicability

Applicable in all breweries.

Economics

No information provided.

Driving force for implementation

Energy savings and related cost reduction.

Example plants

Many breweries apply this technique.

Reference literature

[3, The Brewers of Europe 2018], [72, Brewers Europe 2002], [122, Brewers Europe 2004]

4.4.2.2 Reuse of waste water from the lauter tun

Description

Reuse of waste water as process water for mashing.

Technical description

At the end of mash separation, the residual dilute worts are allowed to drain until an acceptable level of brewers' grains moisture is achieved. After discharge of the grains, the fines deposited beneath the false floor are removed by hot water underplate pressure cleaning and the false floor slots are kept unobstructed by overhead hot water rinsing. These dilute worts are high in TSS, lipids and polyphenols and have traditionally been considered unacceptable for process reuse and are consequently sent to the WWTP. There is a loss in terms of water, energy and extract.

To enable the reuse of the waste water as process water for mashing, the removal of the very fine colloidal-size particles from the weak worts is necessary. This can be achieved by centrifugation or two-stage filtration, i.e. coarse filtration followed by ultrafiltration. After the coarse filtration stage, the waste water is subject to a cross-flow membrane process.

Achieved environmental benefits

Water savings and reduced levels of TSS and COD in the waste water.

Environmental performance and operational data

Waste water from the lauter tun is a significant contributor to a brewery's total waste water. The pollutant load of the lauter tun waste water depends on several factors. In terms of water balance, the lower the spent grain moisture content, the greater the waste water volume. It is advantageous to reduce the volume of dilute wort drainings further, but care is needed not to entrain air or extend the time of wort collection. It is also common practice to apply deep bed

raking during the bed drain-down to speed up the draining of the residual dilute worts after completion of the wort collection to the kettle. The more aggressively this technique is employed, the more fines pass through to the waste water. A higher level of retained spent grains after discharge inevitably results in more fines/COD being entrapped in the false floor plate and removed by the underplate pressure cleaning and going to the waste water.

An example UK brewery developed a pilot plant to deal with a specific highly polluted waste water stream separately from the rest of the waste water. The lauter tun produced approximately 20 % of the total waste water load of the brewery, as shown in Table 4.4.

Table 4.4: Waste water characteristics in a brewery

Parameter	Concentration		Contribution of the lauter tun to the total load (%)
	Total brewery waste water (mg/l)	Lauter tun waste water (mg/l)	
SS	800	6 540	27
COD	2 000	13 100	22

Source: [61, UK 2002]

Before ultrafiltration can commence, it is necessary to remove coarse particles sized greater than 100 μ . A total of 70 % of the suspended solids are easily settleable and likely to be removed by coarse filtration.

After the coarse filtration stage, the waste water is subject to a cross-flow membrane process. The cross-flow membrane filter retained 99 % of the TSS and 53 % of the COD, allowing for a five-fold concentration effect.

The permeate post UF has undergone a 99 % reduction in suspended solids, a 45 % reduction in polyphenols and a 99 % reduction in lipids. This can reportedly be used as a 1 to 3 substitute for hot mashing water in the process. The reduction in pollution load is summarised in Table 4.5.

Table 4.5: Summary of the pollution reduction results when treating lauter tun waste water

	Lauter tun waste water	30 μ filter waste water	Ultrafiltration 100 nm	
			Permeate	Concentrate
Volume (m ³)	13	13	10.5	2.5
Total solids (mg/l)	6 540	3 110	38	16 010
COD (mg/l)	13 100	13 100	7 623	36 104

Source: [61, UK 2002]

Cross-media effects

Extra electricity consumption is required to run filter pumps, the cross-flow membrane system and ultrafiltration.

Technical considerations relevant to applicability

No information provided.

Economics

It is reported that in the UK most breweries discharge their waste water into a MWWTP for treatment. The MWWTP, which is usually a water company, charges for this service. The total cost of the treatment of the lauter tun has been estimated to be about GBP 97/brew. Assuming 3 000 brews in a year this amounts to about GBP 291 000/year.

The reduced COD loading to the MWWTP reduces the waste water cost by about GBP 13/brew. The permeate used as mashing water results in a saving in hot water, which is only actually achieved with an appropriate brewhouse hot liquor balance. In this instance, the recovered hot water still required water make up. The estimated total savings were about GBP 59/brew, or about GBP 176 000/year. Annual operating costs were estimated to be about GBP 28 000, therefore the net savings were estimated to be about GBP 50 000. The installation cost was about GBP 300 000, and therefore the payback period is estimated to be 2 years. An additional annual saving of GBP 50 000 would be realised if the UF concentrate was loaded with normal brewers' grains instead of being sent to the MWWTP.

The cost of such an installation will vary significantly from brewery to brewery, depending upon the lauter tun size, flow rates, buffer tank requirements, solids disposal route and degree of automation. In the pilot, from which these economic data were derived, the technique was not integrated into the automated control system of the brewery, nor was it connected to the CIP system. Although these factors may alter the economic assessment, it is reported to be likely that implementation of the lauter tun waste water treatment system would have an attractive financial payback period of 1–2 years.

Driving force for implementation

Water savings and reduced load to the waste water treatment plant.

Example plants

A brewery in the UK.

Reference literature

[61, UK 2002]

4.4.2.3 Reuse of pasteurising water

Description

Reuse of overflows from the pasteurisers.

Technical description

To reduce water consumption, overflows from the pasteurisers are collected in stainless steel tanks. Collected water is sent to a cooling tower and returned to the pasteuriser after having being dosed with corrosion inhibitors and biocides for example.

Achieved environmental benefits

Reduced water and chemical consumption. Reduced waste water volume.

Environmental performance and operational data

At an example beer bottling installation, the pasteurisers were responsible for 51 % of the total water consumption of approximately 7 000 m³/week. Although the pasteurisers were designed for regenerative flows, there was a constant demand for cooling water which then overflowed to the drain. There was an average flow of about 10 m³/h with peaks of around 60 m³/h. This constant flow to the WWTP led to losses of corrosion inhibitors and biocides. In addition, there were evaporative losses of about 5 % from the cooling towers, requiring make-up water. After installing a water recovery unit from the pasteurisers on the roof of the building, the total water consumption was reduced to 17 % of the site total. Savings in water and waste water of 80 % and of 23 % in chemicals were achieved.

In this example installation, bottling and canning systems are kept separate as bottle breakage in the pasteuriser can lead to frequent depositing of product, e.g. beer, into the pasteuriser water.

Cross-media effects

Possible development of legionnaires' disease, corrosion or scale build-up.

Technical considerations relevant to applicability

The system can be used for pasteurisers and vacuum pumps.

Economics

In an example packing installation, make-up water costs of approximately EUR 0.8/m³ plus a constant flow to the WWTP of EUR 1.1/m³ were achieved. This equates to EUR 7.2–43.2 being wasted per hour for each of the four pasteurisers. The capital costs were EUR 162 000 with a payback period of around 15 months.

Driving force for implementation

Water savings, reduction of waste water volume and associated cost reduction.

Example plants

A packing installation in the UK.

Reference literature

[8, Environment Agency of England and Wales 2000], [57, Environment Agency of England and Wales 2002]

4.4.3 Techniques to reduce waste**4.4.3.1 Recovery and (re)use of yeast after fermentation**

See also Section 2.3.5.2.

Description

After fermentation, yeast is collected and can be partially reused in the fermentation process and/or may be further used for multiple purposes, e.g. as animal feed, in the pharmaceutical industry, as a food ingredient, or in an anaerobic waste water treatment plant for biogas production.

Technical description

After fermentation, yeast is separated and stored in tanks and, unless it is further used, e.g. as an animal feed (see Section 2.3.5.2), is reused in the fermentation process, used for pharmaceutical purposes, or as a flavouring, or sent to anaerobic WWTPs for biogas production.

Achieved environmental benefits

Reduced waste water pollution. Reduced waste, e.g. when used as animal feed.

Environmental performance and operational data

It is reported that, due to its very high COD level and its tendency to form organic acids, if brewers' yeast is discharged to the WWTP, the pollution load of the waste water is significantly increased.

Cross-media effects

Brewers' yeast can be reused as recovered from the fermentation process (live yeast); however, the yeast has to be kept cool to avoid degradation at the cost of cooling energy. The shelf life can be increased by treating it thermally or chemically. The drying of brewers' yeast requires a substantial amount of steam. For animal feed a preservative can be added like propionic acid [3, The Brewers of Europe 2018].

Technical considerations relevant to applicability

Applicable in breweries, distilleries, ethanol production and wineries.

Economics

Reduced waste water treatment charges. Low potential costs and high potential payback when no treatment of the yeast is required.

Driving force for implementation

Reduction in product loss. Avoiding high waste water treatment charges.

Example plants

Used in breweries and in ethanol production.

Reference literature

[3, The Brewers of Europe 2018], [1, CIAA 2002], [7, Environment Agency of England and Wales 2000], [11, Envirowise (UK) 1998]

4.4.3.2 Recovery and (re)use of natural filter material

Description

After chemical, enzymatic or thermal treatment, natural filter material (e.g. diatomaceous earth) may be partially reused in the filtration process. Natural filter material can also be used, e.g. as a soil improver.

Technical description

Filtration of the beer is carried out before bottling to remove the remaining yeast and insoluble turbid particles. Filtration can be carried out with natural minerals, e.g. bentonite, perlite and diatomaceous earth. The filter material can be collected, to prevent it from being washed into the WWTP. It can be treated for reuse by pressing the spent filter material in order to reduce the water content to lower transport costs and to prevent odours due to the degradation of the organics.

Achieved environmental benefit

Reduced waste.

Environmental performance and operational data

Beer is filtered before bottling in a brewery, using diatom filters: around 4 000 t diatoms/year are needed for a production capacity of 7 million hl/year [170, COM 2015].

It is reported that diatomaceous earth (kieselguhr) can be dehydrated and then channelled into a reactor where it is gently dried and smouldered in a stream of hot air. The exhaust gas leaving the reactor requires treatment. After this process, the diatomaceous earth can be fully reused for filtration purposes. As the diatomaceous earth can be recycled many times, a reduction of filtration and disposal costs is achieved. Final disposal is commonly soil remediation and fertilisation [193, TWG 2015]. Spent kieselguhr can also be used in cement and brick manufacturing [3, The Brewers of Europe 2018].

Many other filter recovery technologies have been developed such as chemical treatment or calcination in order to remove the organic matter and suspended solids to reopen the pores. However, such procedures are unable to regenerate the material completely [41, Rocha dos Santos Mathias et al. 2014].

Cross-media effects

Energy consumption to recover the filter material and associated emissions of odour due to quick degradation of the filter material [30, TWG 2018].

Technical considerations relevant to applicability

Applicable in drinks manufacturing installations.

Economics

No information provided.

Driving force for implementation

Reduced product losses and reduced costs for landfilling of spent filter material.

Example plants

Several breweries in Germany [3, The Brewers of Europe 2018].

Reference literature

[2, IED Forum 2018], [3, The Brewers of Europe 2018], [30, TWG 2018], [41, Rocha dos Santos Mathias et al. 2014], [71, AWARENET 2002], [110, CIAA 2003], [158, Germany 2005], [170, COM 2015], [193, TWG 2015]

4.4.3.3 Use of brewery surplus yeast, rest beer and soft drinks for bioethanol feedstock**Description**

An alternative disposal method which can turn residues like surplus yeast, rest beer and soft drinks into bioethanol, animal feed and CO₂.

Technical description

The majority of the biowaste products (brewers' grains and yeast) are already used as animal feed. Sugar liquids and alcohol containing beer waste fractions are normally disposed of to the WWTP.

This technique can turn surplus yeast, rest beer and soft drinks into bioethanol, animal feed and CO₂. An integrated bioethanol plant can also utilise bakeries' and supermarkets' bakery biowaste to compliment brewery waste to increase fermentation and increase CO₂ production.

The new technology evaporates alcohol from yeast and rest beer. Non-alcoholic waste streams are fermented together with local bakery and supermarket bakery waste. CO₂ from the fermentation process is used in soft drinks production. Liquid animal feed is produced as a by-product, which is sold to local farms.

Achieved environmental benefits

Efficient by-product management.

Environmental performance and operational data

Surplus yeast is evaporated and alcohol is separated from the yeast. The remaining fraction is sold to local farms as liquid animal feed. Rest beer and liquid waste from soft drink production could also be handled in the same way, where the sugars are fermented into ethanol by the continuous fermentation process. Typically, rest beer is evaporated and non-alcoholic waste liquids are mixed with bread. This saves fresh water consumption at the ethanol plant. Carbon dioxide is captured during the fermentation process, which is reused.

In a related unit, biowaste and side products from the food processing industry are turned into 85 % ethanol. The ethanol is then transported to central dehydration unit, where the remaining water is evaporated by membrane technology. When alcohol reaches 99.8 %, it is ready to be mixed with petrol without any additional processing.

Cross-media effects

Potential increase of energy consumption for evaporation of ethanol.

Technical considerations relevant to applicability

A sufficient amount of biowaste product must be available to make the bioethanol production efficient and cost-effective.

Economics

The main economic advantage to the brewery is the possibility to produce ethanol, collect CO₂ from the fermentation and so reduce the amount of CO₂ bought.

Example plants

At least one installation in Finland.

Reference literature

[169, Nordic Council of Ministers 2011]

4.4.4 Techniques to reduce emissions to air

4.4.4.1 Techniques to reduce dust emissions from the brewing process

4.4.4.1.1 Bag filter

General information on the technique is given in Section 2.3.7.2.2.

Environmental performance and operational data

Bag filters are widely used in breweries as a final abatement technique, but in most cases are preceded by a cyclone step.

Table 4.6 shows some installation-specific performance data related to the application of bag filters for abating emissions to air from brewing processes.

Table 4.6: Dust emissions to air from brewing processes after treatment in a bag filter (dry basis)

Installation ID-point of release	Dust (mg/Nm ³)	O ₂ content (%)	Monitoring standard	Frequency of monitoring	Additional information
072-1	0.18	NI	EN 13284-1	NI	Raw material transfer to silos Cyclone step before
399-7	0.30	NI	EN 13284-1	Once every three years	Vibratory sieves of raw material Cyclone step before
360-1	1.20	21.00	EN 13284-1	Yearly	Adjunct transfer to brewhouse
157-7	1.20	20.90	EN 13284-1	Yearly	Adjunct transfer to brewhouse Cyclone step before
158-3	<1.39	20.90	EN 13284-1	Once every three years	Milling process Cyclone step before
157-10	1.50	20.90	EN 13284-1	Yearly	Adjunct transfer to brewhouse Cyclone step before
399-6	1.67	NI	EN 13284-1	Once every three years	Adjunct transfer to brewhouse Cyclone step before
166-2	1.70	20.90	EN 13284-1	Every five years	Malt reception
157-8	1.80	20.90	EN 13284-1	Yearly	Grain cleaning Cyclone step before
157-5	1.90	20.90	EN 13284-1	Yearly	Grain transfer Cyclone step before
360-4	2.00	21.00	EN 13284-1	Yearly	Malt transport system from silos to the brewhouse
157-3	2.00	20.90	EN 13284-1	Yearly	Adjuncts transfer to brewhouse Cyclone step before
157-1	2.10	20.90	EN 13284-1	Yearly	Adjuncts transfer to brewhouse Cyclone step before
157-6	2.20	20.90	EN 13284-1	Yearly	Malt transfer Cyclone step before
160-5	2.34	20.90	EN 13284-1	Yearly	Grain cleaning Cyclone step before
166-4	3.20	20.90	EN 13284-1	Biennial	Malt milling & transfer to the brewhouse
158-2	3.54	20.90	EN 13284-1	Once every three years	Grain cleaning Cyclone step before
165-1	3.90	20.90	EN 13284-1	Twice a year	Malt discharge
160-10	4.34	20.90	EN 13284-1	Yearly	Malt transfer Cyclone step before
160-8	9.38	20.90	EN 13284-1	Yearly	Milling process Cyclone step before
159-4	15.20	20.90	EN 13284-1	NI	Milling process Cyclone step before
160-4	22.00	20.90	EN 13284-1	Yearly	Raw material transfer to silos (starch) Cyclone step before

NB: NI = no information provided
Source: [193, TWG 2015]

Reference literature

[193, TWG 2015]

4.4.4.1.2 Cyclone

General information on the technique is given in Section 2.3.7.2.3.

Environmental performance and operational data

Cyclones are widely used as an abatement technique for breweries' emissions to air, but usually before a final bag filter step (see Table 4.6). Table 4.7 shows some installation-specific performance data related to the application of cyclones for abating emissions to air from brewing processes.

Table 4.7: Dust emissions to air from brewing processes after treatment in a cyclone (dry basis)

Installation ID-point of release	Dust (mg/Nm ³)	O ₂ content (%)	Monitoring standard	Frequency of monitoring	Additional info
360-2	1.75	21.00	NI	Yearly	Malt transport system
165-3	7.63	21.00	EN 13284-1	Twice a year	Sand removal
NB: NI= no information provided Source: [193, TWG 2015]					

Reference literature

[193, TWG 2015]

4.4.4.2 Techniques to reduce odour

4.4.4.2.1 Heat recovery from wort kettle vapour

See also Section 4.4.1.3.

Recovering heat from wort kettles saves energy by condensing approximately 95 % of the vapour. This also reduces odour emissions because condensable odorous vapours are removed from the exhaust air.

4.4.4.3 Carbon dioxide recovery and purification

Description

The CO₂ generated during the fermentation process is collected, cleaned, compressed, dried, purified and liquefied.

Technical description

CO₂ released during fermentation is passed to a recovery unit. The CO₂ to be recovered contains volatile components present or produced during fermentation including oxygen, fusel oils and carbonyl and sulphur compounds with very low flavour thresholds, e.g. hydrogen sulphide. For this reason, the CO₂ has to be purified to the degree necessary for its intended use.

The purification process or conditioning includes a foam separator, gas scrubbing with water to reduce the sulphur compounds, drying, flavour removal with activated charcoal, oxygen removal and compressing to liquid for its storage. It can then be drawn off as needed from the storage tank, revaporised and used in production, or sold as product. This biogenic CO₂ can, for example, be used for technical uses or for food and drink applications.

The cleaned and dried gas is cooled to a temperature between -30 °C and -40 °C, mostly with the help of NH₃ refrigeration, and then liquefied. Any gases possibly remaining, such as O₂ or N₂, do not condensate, and are blown out to increase the purity of the CO₂. If this is not

sufficient for the intended use, rectification can be included downstream. The liquid CO₂ is subsequently stored in the storage tank at approximately -25 °C to -30 °C and 14–16 bar. As a rule of thumb, this should have an approximate size of 100 times the hourly throughput.

Achieved environmental benefits

Reduced CO₂ emissions at installation level. Reduced consumption of fossil fuels and energy for the production of CO₂ especially for use in the installation (generating a tonne of CO₂ requires about 140 kWh).

Environmental performance and operational data

In the brewing sector, the reduction in CO₂ emissions with this system is around 2 kg/hl (20 kg/m³) of beer produced.

Untreated CO₂ with an impurity of 20–1 000 ppm can be recovered from the fermentation process. The oxygen level in the liquefied CO₂ can be reduced from an initial value of 40–1 000 ppm to an output purity of 5 ppm. This is achieved by the oxygen reduction system.

Figure 4.19 shows the process sequence in the CO₂ conditioning system.

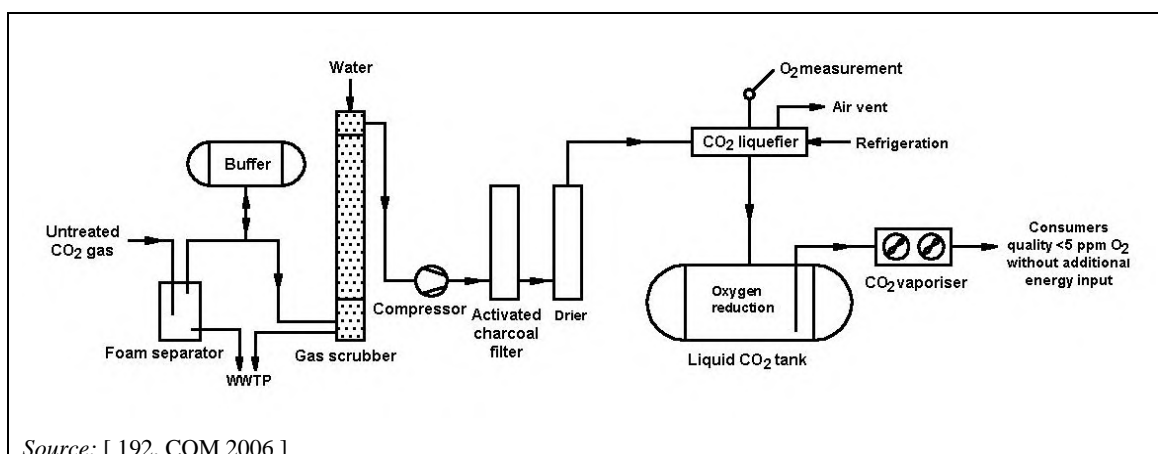

Source: [192, COM 2006]

Figure 4.19: Process flow diagram of a CO₂ conditioning system in a large brewery

If closed-circuit cooling water is used for cooling the air compressors and the CO₂ compressor, this prevents water losses and minimises waste water volumes.

The decision whether to sell CO₂ produced as a co-product to another sector may be based on the quality available.

Cross-media effects

Energy and water consumption is necessary for processing the CO₂. Activated carbon and desiccant have to be replaced and discharged regularly.

Technical considerations relevant to applicability

The technique is applicable in breweries, wineries, distilleries, ethanol and cider production. The opportunities for using the recovered CO₂ vary between sectors, and are as follows:

- neutralising waste water, with minimum purification – all fermenting sectors;
- carbonating drinks – brewing, sparkling wine, cider, soft drinks and mineral water;
- as a carrier for drinks dispensing, e.g. beer, cider and carbonated soft drinks;
- for counter pressure in filtration units; tanks and bottles, e.g. beer, cider and carbonated soft drinks.

Economics

Industrial gas companies can supply CO₂, which is usually a co-product from other sectors, at a cheaper price than the production cost in the installation.

Driving force for implementation

- Avoiding CO₂ emissions due to replacement of fossil-derived CO₂ and avoiding the need to purchase CO₂ from third parties.
- The use of own-site recovered CO₂ avoids the risk of contamination, taste and odour problems from off-site sources.

Example plants

Used in the brewing and ethanol production sector.

Reference literature

[35, Germany 2002], [88, CIAA-CEFS 2003], [94, Germany 2003], [109, Finland 2003], [192, COM 2006]

4.5 Emerging techniques

4.5.1 External cooling of the fermentation tank

Description

External cooling of the fermentation tank.

Technical description

Cooling of a fermentation tank is traditionally carried out by jacket cooling. As the traditional fermentation tank is not equipped with any kind of mechanical agitation, mixing of the beer is only driven by the gravitational forces of cooler beer sinking to the bottom of the tank along the cooled tank walls and warmer beer in the centre of the tank rising to the top. As the only driver in the tank is gravitational forces, the flow velocity down the smooth vertical stainless steel wall will be low and the corresponding heat transfer coefficient from convection (natural convection) will be low.

The idea of this technology is to replace traditional inefficient jacket cooling of the fermentation tank with more efficient cooling in an external heat exchanger which the beer is forced through by a circulation pump. The advantages of this cooling technology in comparison with the jacket cooling technology are the much larger overall heat transfer achievable with an external heat exchanger than with jacket cooling and the arbitrary size of the heat transfer area which is no longer fixed to the tank geometry. The heat transfer rate is primarily achieved by mechanically increasing the flow velocity over the heat transfer surface by a pump and by improving the conduction heat transfer coefficient by using very thin plates between the beer and cooling media.

The external cooling system results in a smaller temperature difference of the cooling media and enables a higher cooling media temperature which means that the evaporation temperature of the refrigerant in the cooling plant can be increased, leading to improved energy efficiency and increased capacity of the cooling plant. In addition to this environmental advantage, the forced agitation provided by circulating the beer leads to better mixing of the yeast and beer in the fermenting process which leads to a faster fermentation process.

Achieved environmental benefits

Reduced energy consumption.

Reference literature

[169, Nordic Council of Ministers 2011]

5 DAIRIES

5.1 General information about the sector

More than 12 000 dairy processing sites exist in EU, involving around 300 000 direct jobs. Five of the ten global top dairy companies are European and the European milk processing industry brings more than EUR 9.3 billion to the overall EU trade balance [206, EDA 2015].

Farms across the EU-28 produced approximately 164.8 million tonnes of milk in 2014, of which 159.6 million tonnes (or 96.8 %) were cows' milk. Milk from ewes, goats and buffaloes represented 3.2 % of the total production. The majority of the milk produced on farms was delivered to dairies and the remaining amount was used on the farms (see Figure 5.1).

Between 2013 and 2014 the production of cows' milk on farms in the EU-28 increased by almost 5.8 million tonnes (3.8 %), while the number of dairy cows increased by 0.4 %. The EU -28's dairy herd of 23.6 million cows in 2014 had an estimated average yield of 6 777 kg per head.

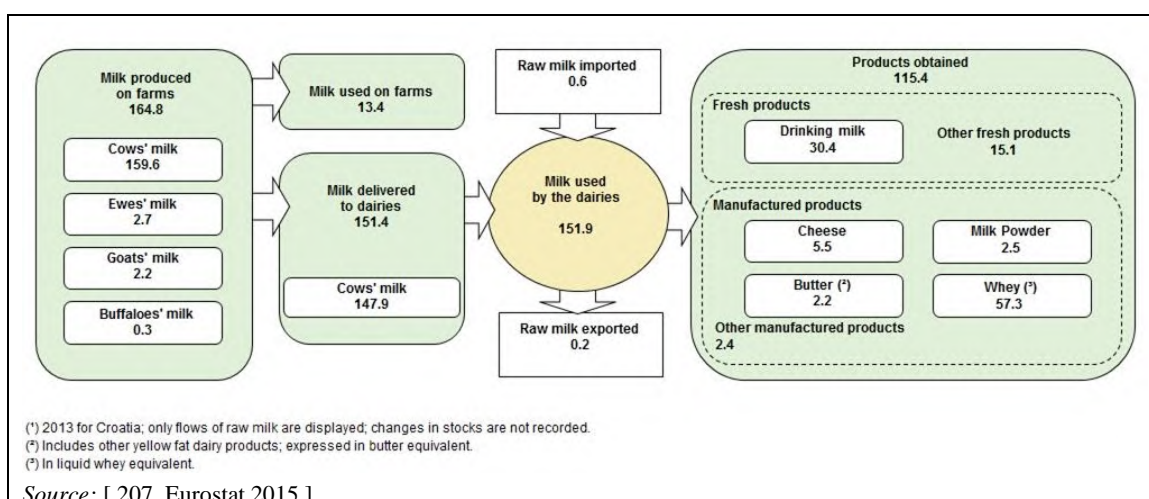

Figure 5.1: Production and use of milk in the EU-28 in 2014 (million tonnes)

Just over one fifth (21.2 %) of all the cows' milk collected by EU-28 dairies in 2014 came from Germany, while slightly more than a sixth of the total (17.1 %) originated from dairies in France (see Figure 5.2). Dairies collected relatively little milk from other animals (sheep, goats and buffaloes) in most EU Member States. However, in Greece the volume of milk collected from other species (669 000 tonnes) was higher than the level of milk collected from cows (615 000 tonnes). In Italy and France the quantities of milk collected from other animals were similar to Greece, but these volumes were dwarfed by the respective quantities of cows' milk that their dairies collected. Spain was the country that presented the highest quantity of milk from other animals (1 120 000 tonnes), which represented 14 % of the total milk collected in Spain.

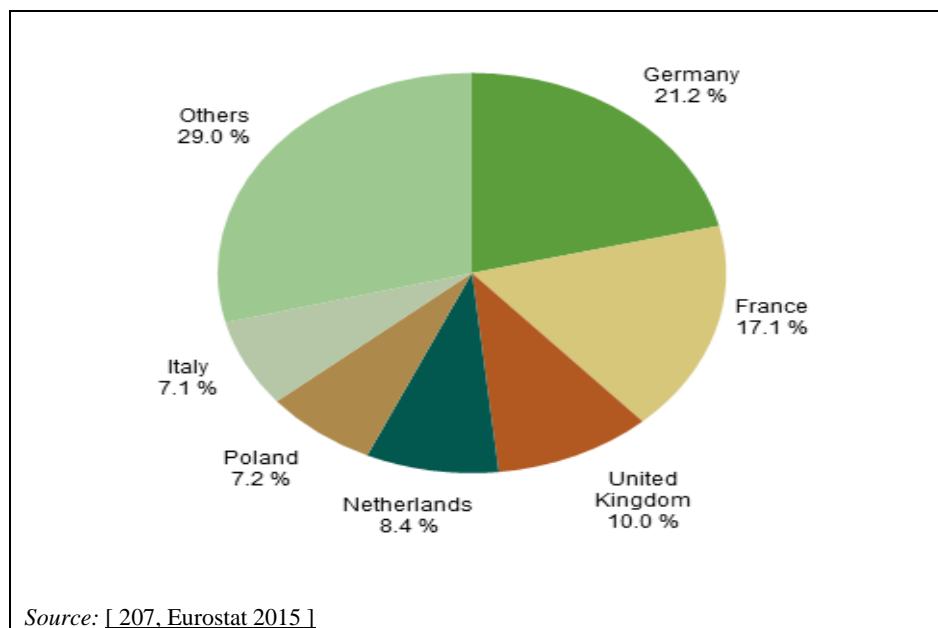

Figure 5.2: Collection of cows' milk by dairies in 2014 (% share of EU-28 total)

The milk delivered to dairies is converted into a number of fresh products and manufactured dairy products (see Figure 5.3). Some 68.8 million tonnes of raw milk in the EU-28 in 2014 were used to produce mainly cheese, drinking milk, milk powder, butter, skimmed milk and buttermilk. Close to a quarter (24.3 %) of the estimated 30.4 million tonnes of drinking milk produced in the EU-28 in 2014 came from the United Kingdom, despite this Member State accounting for only about one tenth of the milk produced in the EU-28. This relative specialisation was also observed for other dairy products: for example, Germany, Italy and the Netherlands accounted for almost three quarters (70.3 %) of the 5.5 million tonnes of cheese produced across the EU-28 in 2014.

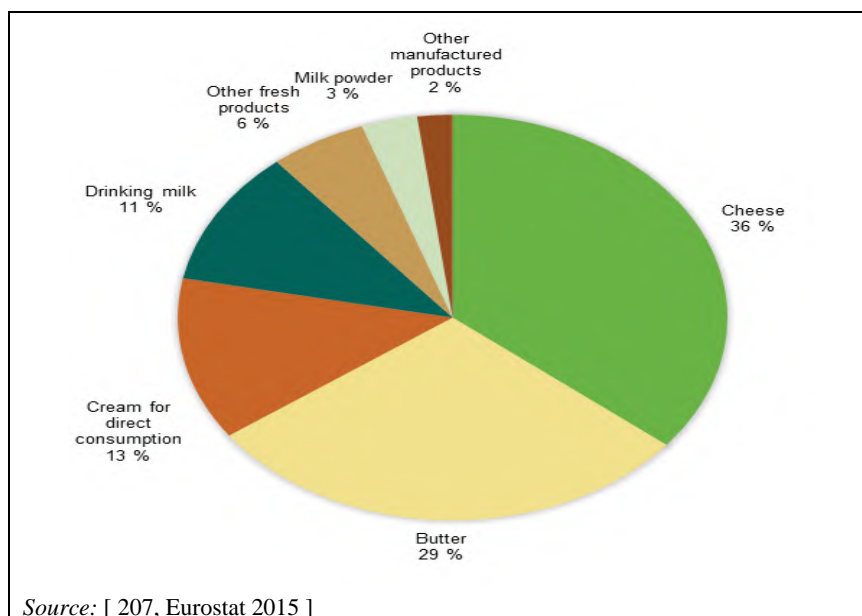

Figure 5.3: Utilisation of whole milk in the EU-28 in 2014

In some MS, e.g. Italy, the large majority of the dairy installations are specialised to produce multiple subcategories of raw milk, such as: market milk; milk and milk derivatives, and/or yoghurt and or vegetables; milk, milk derivatives and cheese; soft and fresh cheese and/or butter; hard cheese; soft, fresh and hard cheese.

5.2 Applied processes and techniques

Milk is approximately 87 % water, with the remainder being protein, fat, lactose, calcium, phosphorus, iron and vitamins. Cows' milk is primarily consumed, but goats' and sheep's milk are also consumed in significant quantities. A number of dairy products such as cream, cheese and butter are produced from milk.

5.2.1 Milk and cream

Raw chilled milk is received at the dairy and transferred to bulk storage. The milk may be centrifugally separated to produce skimmed or semi-skimmed milk and a cream stream. The milk is then heat-treated by a variety of methods such as pasteurisation and sterilisation, also known as UHT (ultra-high temperature). Heat processing may be a batch or continuous operation depending upon the quantity of the milk to be processed and the method employed.

The milk is first homogenised. Homogenisation disperses fat globules and prevents separation of the cream component. To achieve a sufficient creaming stability for pasteurised milks with a relatively short shelf life, reduction of the fat globules' size to a mean diameter of 1 μm to 2 μm is required, while the long-shelf-life UHT milks require a much greater reduction in fat globule size, $\leq 0.7 \mu\text{m}$.

Another effect of homogenisation is the large increase in exposed fat area, which greatly favours the action of lipases. For this reason, it is normal practice to pasteurise the milk to inactivate the lipase, immediately after homogenisation. Figure 5.4 shows a flow sheet for a short-time pasteurised milk process.

Typical heating parameters for a continuous pasteurisation process are 72 °C for 15 seconds. This is known as high-temperature short-time pasteurisation (HTST). Hot milk is often used to partially heat incoming cold milk in a heating step known as regeneration. Following pasteurisation, the milk is rapidly cooled to < 7 °C. Milk which is not in-container heat-processed is filled and sealed in containers under clean or aseptic conditions. Incoming milk may be homogenised after the regeneration stage, before being pasteurised.

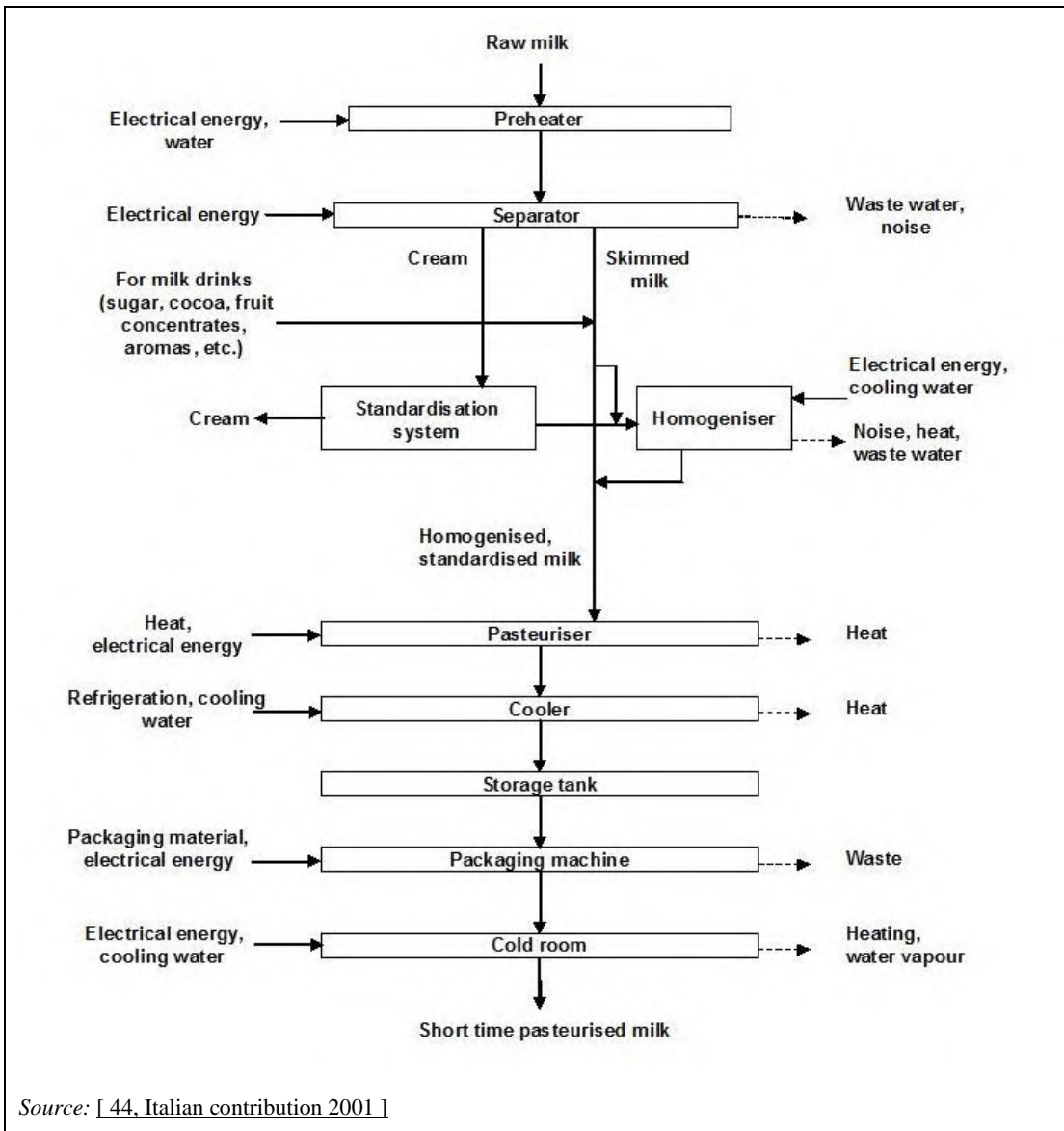

Figure 5.4: Short-time pasteurised milk process

UHT treatment or sterilisation is used to increase the shelf life of the product. Continuous UHT treatment at a minimum of 135 °C is carried out for one second. This can be done in two different ways: heating it indirectly, using heat exchangers with various types of plates and pipes, or in two stages, i.e. first heating the milk indirectly to approximately 80 °C and then heating it directly by mixing steam and milk. The ratio of the weight of steam and milk used is approximately 1:10. If direct heating is applied immediately after the heat treatment, the milk is then cooled by expanding it under a vacuum to extract the steam mixed with the product in the sterilisation phase. This is also called flash cooling. The end temperature of the milk immediately returns to its level prior to mixing with the steam. Cooling by indirect exchange with a coolant or countercurrently with the incoming product then follows. Figure 5.5 summarises the production of UHT milk.

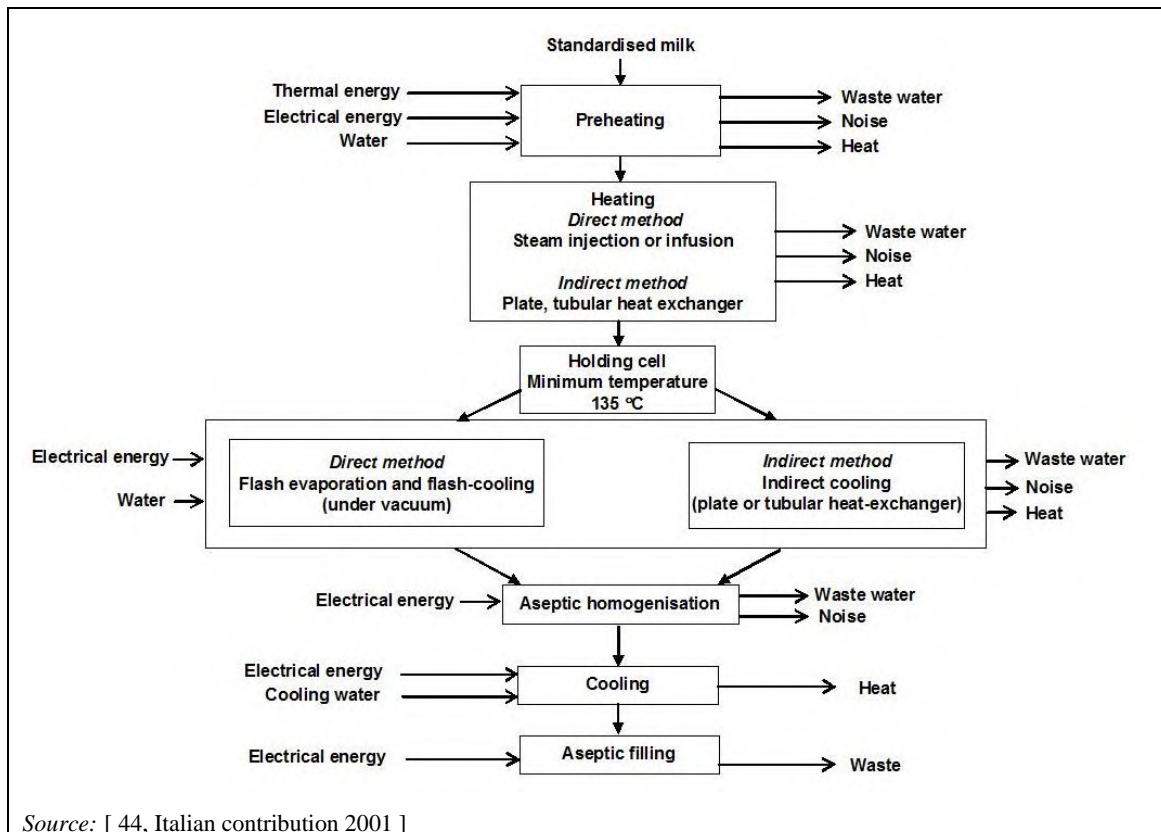

Figure 5.5: Production of UHT milk

The heat treatment for long-life sterilised milk consists of two phases. The first phase is a continuous heat treatment or pre-sterilisation, similar to that described for UHT treatment. The second phase consists of the final treatment of the closed container after filling and sealing the pre-sterilised product. The second heat treatment generally takes place in an autoclave in batches or in a continuous retort at approximately 110–125 °C for 20 to 40 minutes with a sprinkler cooling end phase. Long-life sterilised milk and other dairy products are packaged in closed containers such as plastic or glass bottles. Figure 5.6 summarises the production of sterilised milk.

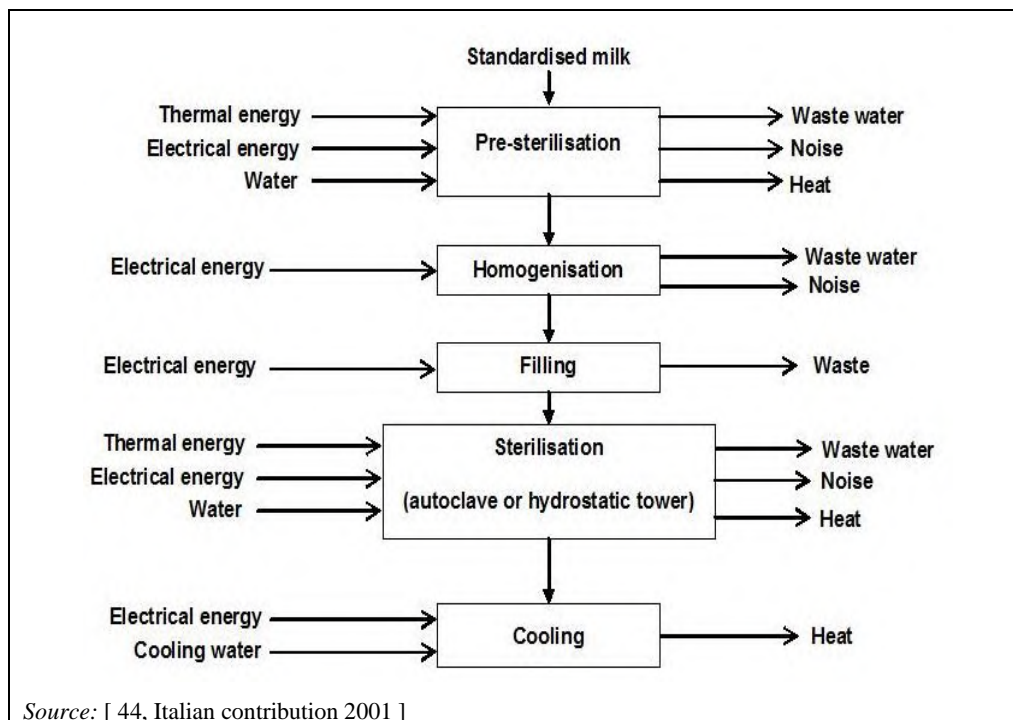

Figure 5.6: Production of sterilised milk

Lactose-free milk drinks are products having the normal characteristics and taste of milk but that do not contain lactose. They are manufactured by separating part of the lactose of milk by ultrafiltration or chromatographic column and the rest of the lactose is broken down by lactase. The milk drink is pasteurised or UHT-treated before packaging. Manufacture of lactose-free milk drinks require more steps and more technology, thus the process involves a higher specific waste water discharge compared to processing of normal liquid milk.

5.2.2 Condensed and powdered milk

The first stage in the production of condensed and powdered milk is the concentration of the raw milk. Homogenised milk is usually concentrated with evaporators. Falling film evaporators are generally used followed by a drying step using a spray dryer. Alternatively, RO can be used to mechanically remove some of the water from the milk, without the application of heat. Electrical power is used to pump liquid through a semi-permeable membrane to increase the concentration of solids. Doubling of the concentration of milk and whey is common [19, German Dairy Association 2001]. The powder is typically agglomerated to improve reconstitution. Dry whole milk is susceptible to oxidative rancidity and may be packaged in a protective atmosphere to extend its shelf life. These processes are shown in Figure 5.7 and Figure 5.8.

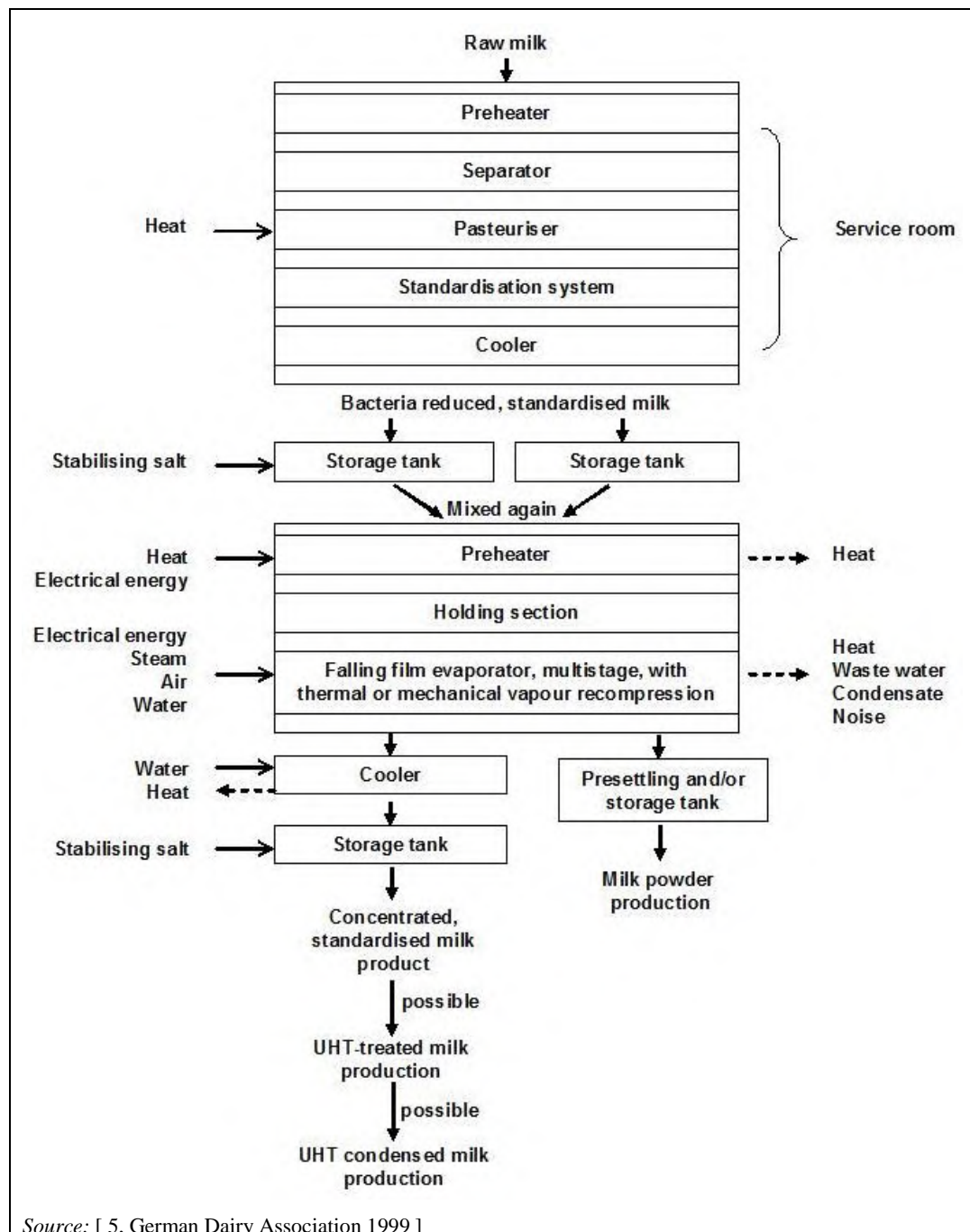

Figure 5.7: Flow sheet of processes for condensed products (e.g. UHT condensed milk) and intermediate products (e.g. milk concentrates)

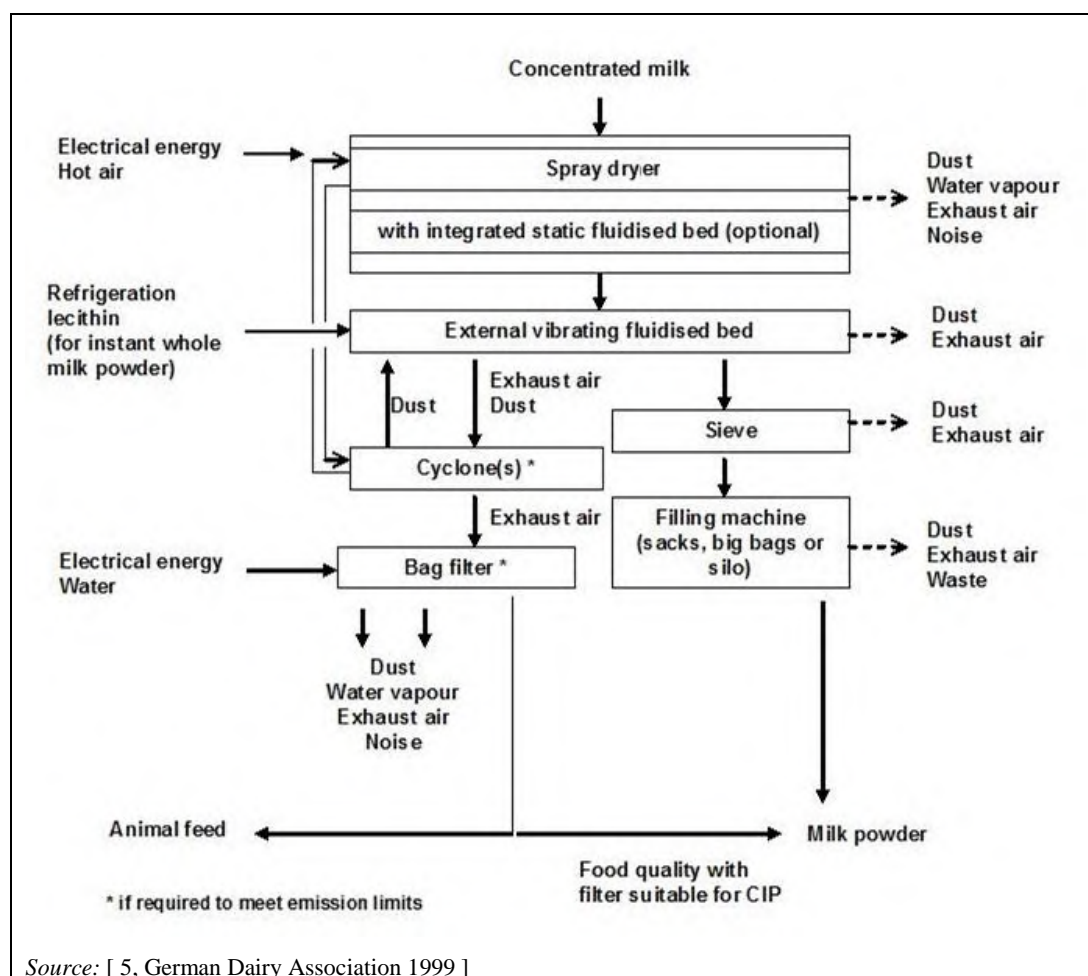

Figure 5.8: Flow sheet of powdered milk production

Two different principles can be applied for drying; hot air drying and surface drying by heat conduction through a heat transfer system.

In hot air drying, hot air is used as the heating medium and is in direct or indirect contact with the liquid product. The heat transferred from the hot air to the product causes evaporation of the water content.

In surface drying by heat conduction through a heat transfer system, the heating medium is not in contact with wet food but separated from it by a heat transfer surface. The heat is transferred by conduction through the surface, and by convection from the hot surface to the food product for evaporating and removing water from the food. This has two main advantages compared to hot air dryers; less air volume is required and, therefore, thermal efficiency is higher, and the process may be carried out in the absence of oxygen.

The dryers used are spray, roller, and vacuum band and vacuum shelf dryers.

In spray drying, the material to be dried is suspended in air, i.e. the liquid is converted into a fog-like mist or atomised liquid, providing a large surface area. The atomised liquid is exposed to a flow of hot air in a drying chamber. The moisture evaporates quickly and the solids are recovered as a powder consisting of fine, hollow, spherical particles. Air inlet temperatures of up to about 250 °C or even higher, depending on the type of product, are used, but, due to evaporation, the air temperature drops very rapidly to a temperature of about 95 °C, which is the outlet temperature of the air. The product temperature is 20–30 °C below the air outlet temperature. Heating the drying air can be accomplished by steam or by direct gas-fired air heaters or by indirect heaters fired by gas, liquid or solid fuels. Spray drying is applied on a large scale in the dairy industry.

Generally, as an integral part of the process, the exhaust air is passed through cyclones and/or filters to recover particulate materials or dust which are carried over in the exhaust air. The recovered material is incorporated back into the product.

The principle of roller drying is that a thin film of material is applied to the smooth surface of a continuously rotating, steam-heated metal drum. The film of the dried material is continuously scraped off by a stationary knife located opposite the point of application of the liquid material. The dryer consists of a single drum or a pair of drums with or without satellite rollers. The steam pressure applied in the drums can vary from 4 bar to 8 bar, depending on the product. Roller drying is applied for milk, starch and potato flakes for example.

Finally, in vacuum band and vacuum shelf dryers, food slurry is spread or sprayed onto a steel belt, which passes over two hollow drums within a vacuum chamber. The food is first dried by the steam-heated drum, and then by the steam-heated coils or radiant heaters located over the belt. The dried food is cooled by the second water-cooled drum and removed by a doctor blade. The rapid drying and limited heat damage to the food makes this method suitable for heat-sensitive foods.

5.2.3 Butter

Butter is produced from cream which is centrifugally separated from pasteurised milk. The cream contains around 35–40 % milk fat. The process is basically a mechanical one in which cream, an emulsion of oil in water, is transformed to butter, an emulsion of water in oil. This is achieved by a process of batch or continuous churning. Cream is rapidly chilled and held at that temperature for a set period in a process known as ageing. The cream is then subjected to churning and working. Churning agitates the cream to partially break down the oil in the water emulsion until fat globules bind together to produce butter grains. The liquid phase called buttermilk is removed and the butter grains are washed in water. Salt may be added before the working stage of the process begins. This involves slow agitation of the grains, subjecting them to a kneading and folding action. The butter is packaged and stored, typically in chilled or frozen storage. A number of continuous techniques are available such as methods in which cream is subjected to high-speed churning and continuous working. Figure 5.9 summarises continuous butter-making.

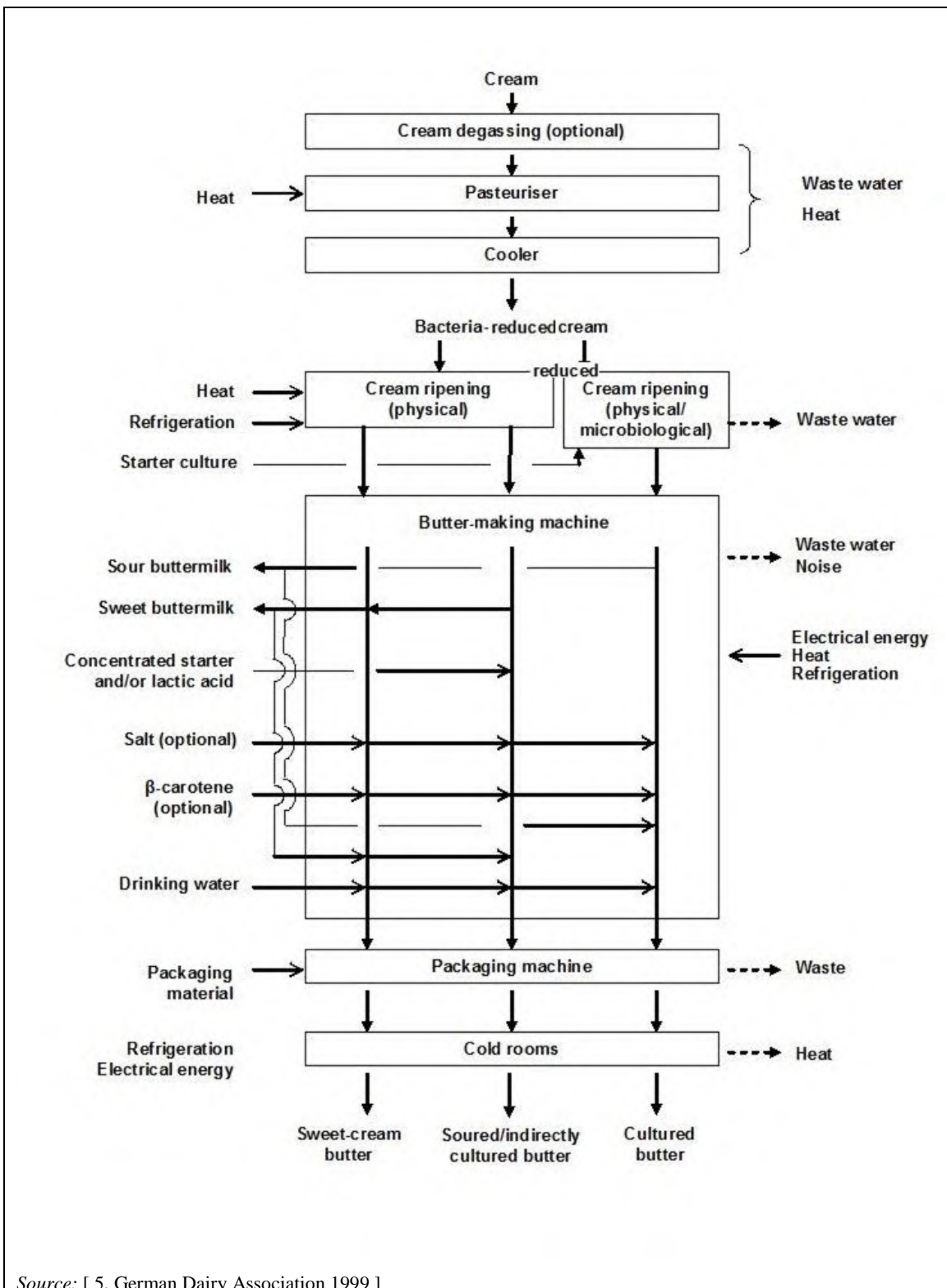

Figure 5.9: Continuous butter-making

5.2.4 Cheese

There are a very wide range of cheese varieties and many subtle differences in processing methods. In general, however, the following process steps apply: production of a coagulum through the action of rennet and/or lactic acid, separation of the resulting curds from the whey, and manipulation of the curds to produce the desired characteristics of the cheese.

The traditional manufacture of cheese is a manual process but modern processes are highly mechanised. Starter cultures are added to the milk to produce lactic acid and rennet is then used to coagulate the milk protein. After curd formation, the curd is cut into small pieces. After cheese-variety-dependent temperature treatment, whey and curd are separated and curd is pressed into blocks. The blocks are salted in salt brine and then wrapped to protect them against moisture loss and mould growth during ripening. During cheese ripening the typical flavour for the particular cheese variety develops. In the manufacturing process of mozzarella, texturing of the cheese involves compressing and stretching the curds. In the manufacturing of cheddar-type cheeses, the curd blocks are milled, salt is added, and the curds are pressed. Pressed cheese is wrapped to protect it against moisture loss and mould growth during storage.

Figure 5.10 shows a general flow sheet of the manufacture of cheese.

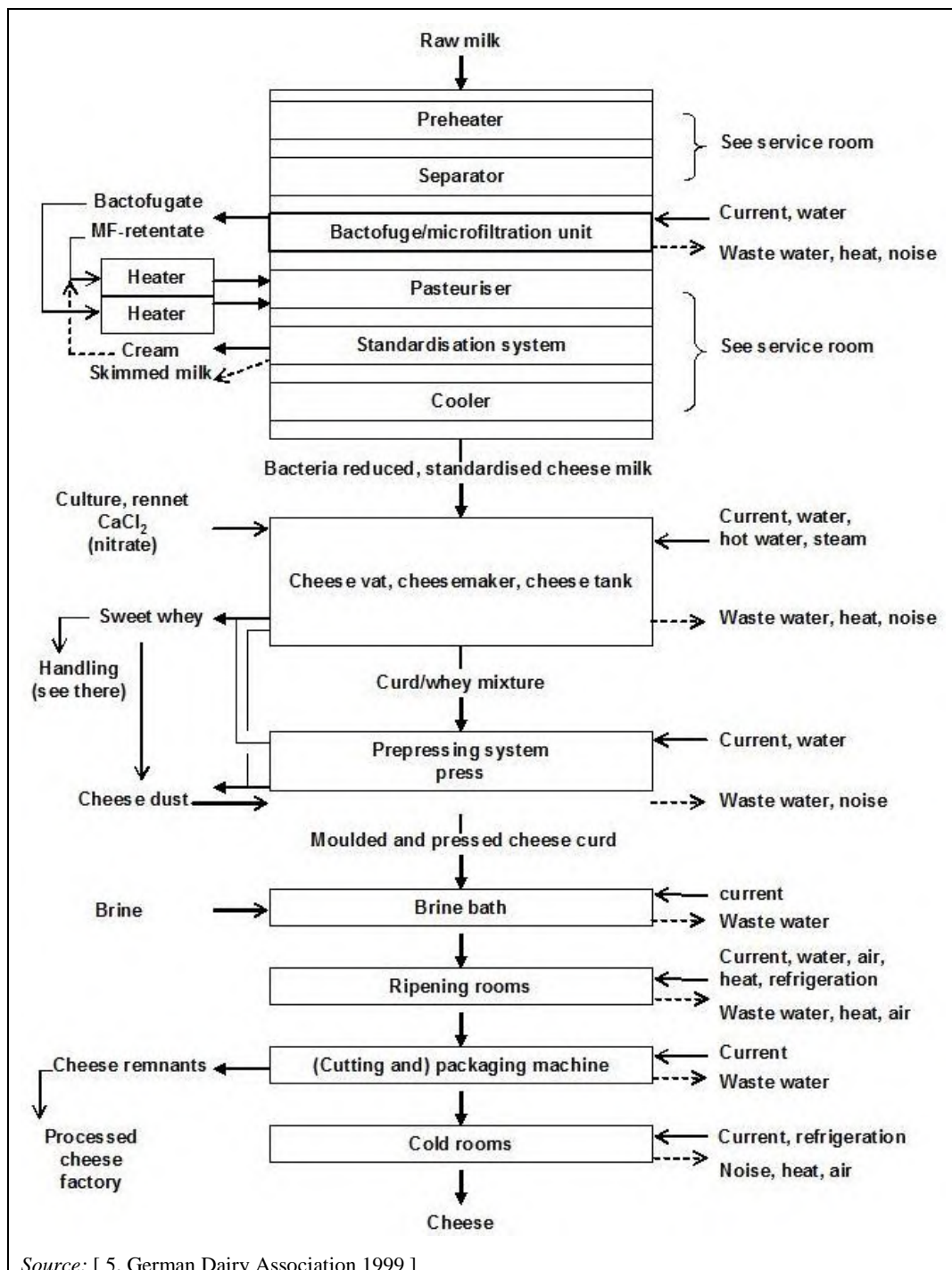

Figure 5.10: Manufacture of cheese

A further process involves melting. In the manufacture of processed cheese, milled cheese and other ingredients are put into a processing kettle and heated to a temperature normally not less than 75 °C to ensure the complete pasteurisation of the processed cheese. Agitation during processing is important for a complete emulsification of the processed cheese. The temperature and duration of the process depends on the type of processed cheese aimed for and the nature of the raw cheese.

Temperature is one of the key factors that influence milk curdling. The required temperature is obtained by using either heat exchangers or by direct injection of steam into the curdling vat. The temperature is between 30 °C and 40 °C. Starters and other ingredients are added to the milk. These ingredients help determine the specific characteristics of the final product. Curdling is carried out in suitable vats or tanks, using either enzymatic coagulants, i.e. animal or microbial rennet, or acidifying starters.

When enzymatic coagulants or acidifying starters are used, a casein jelly is formed which encloses the fat. The jelly will have different characteristics depending on which coagulant method is used. This is important for achieving the desired final product. The curd is produced by the separation of the whey, which is then gathered and sent for further processing as appropriate. To obtain further separation of the whey, e.g. to obtain a hard or semi-hard cheese, another heat treatment is given to the curd under stirring at up to 40–53 °C. For other kinds of cheese, such as mozzarella or provolone, as well as the curd being heated at a higher temperature, mechanical processing is also carried out to obtain the characteristic stretching/melting properties. Furthermore, organic acids are used to control the pH and to hold the curd at the right pH for the stretching properties to form.

5.2.5 Yoghurt

Yoghurt is a fermented milk product which differs from cheese in that rennet is not added and thickening occurs as a result of acidification by lactic acid bacteria. The main ingredients of yoghurt include milk; milk powders or concentrated milk or ultra-filtered milk; and stabilisers, such as modified starches. Most of the yoghurt produced is manufactured in bulk before the addition of fruit and/or flavourings.

The main steps in the manufacture of yoghurt (also similar in the case of some other fermented milk products, e.g. kefir) are as follows. The fat and non-fat solids content of the milk is first increased by the addition of milk powders. Stabilisers may be added at this stage. The milk is then homogenised at a temperature of around 55 °C and heat-treated at 80–90 °C for 30 minutes in a batch process, or 90–95 °C for 5 minutes in a continuous process. The heat-treated milk is then cooled to around 40–43 °C and seeded with two starter organisms – *Streptococcus salivarius* subspecies *thermophilus* and *Lactobacillus delbrueckii* subspecies *bulgaricus*. Fermentation takes around 4 hours. At the end of the process, the product is cooled to 15–20 °C, using either tank cooling coils or, more commonly, tubular or plate heat exchangers. Fruit and flavours are blended into the yoghurt which is then cooled to less than 5 °C and filled into pots ready for storage and distribution. Figure 5.11 shows the yoghurt production process. Set yoghurt is fermented in the package, while stirred yoghurt is fermented in a tank before being packaged.

In lactic acid fermentation, lactose or other sugars are converted into lactic acid and small amounts of other components. Lactic acid formation is accompanied by a decrease in pH, which is important for the taste, the aroma and the preservation of the product. There are several species of bacteria which are able to produce lactic acid. Each species gives its own typical taste and aroma. Lactic acid fermentation is an anaerobic process. It is sometimes necessary to remove as much of the oxygen as possible to enhance the fermentation process. Lactic acid fermentation is carried out at 20–40 °C.

To start the process, bacteria cultures known as starters are added to the raw material to be fermented. The preparation of starter cultures is a sensitive process since the risk of airborne infection should be reduced to an absolute minimum. Starter cultures are, therefore, prepared in a separate room supplied with filtered air with a slight positive pressure compared to normal atmospheric pressure. The equipment cleaning system is also carefully designed to prevent detergent and steriliser residues from coming into contact with the cultures and spoiling them. These very strict hygiene constraints, coupled with the requirements of the temperature regulation, i.e. heat treatment of the substrate first and then cooling, require a specific energy consumption and use of cooling water. In addition, yoghurt and other fermented milk products are viscous, thus flushing out the product residues and cleaning needs more water than flushing and cleaning of market milk.

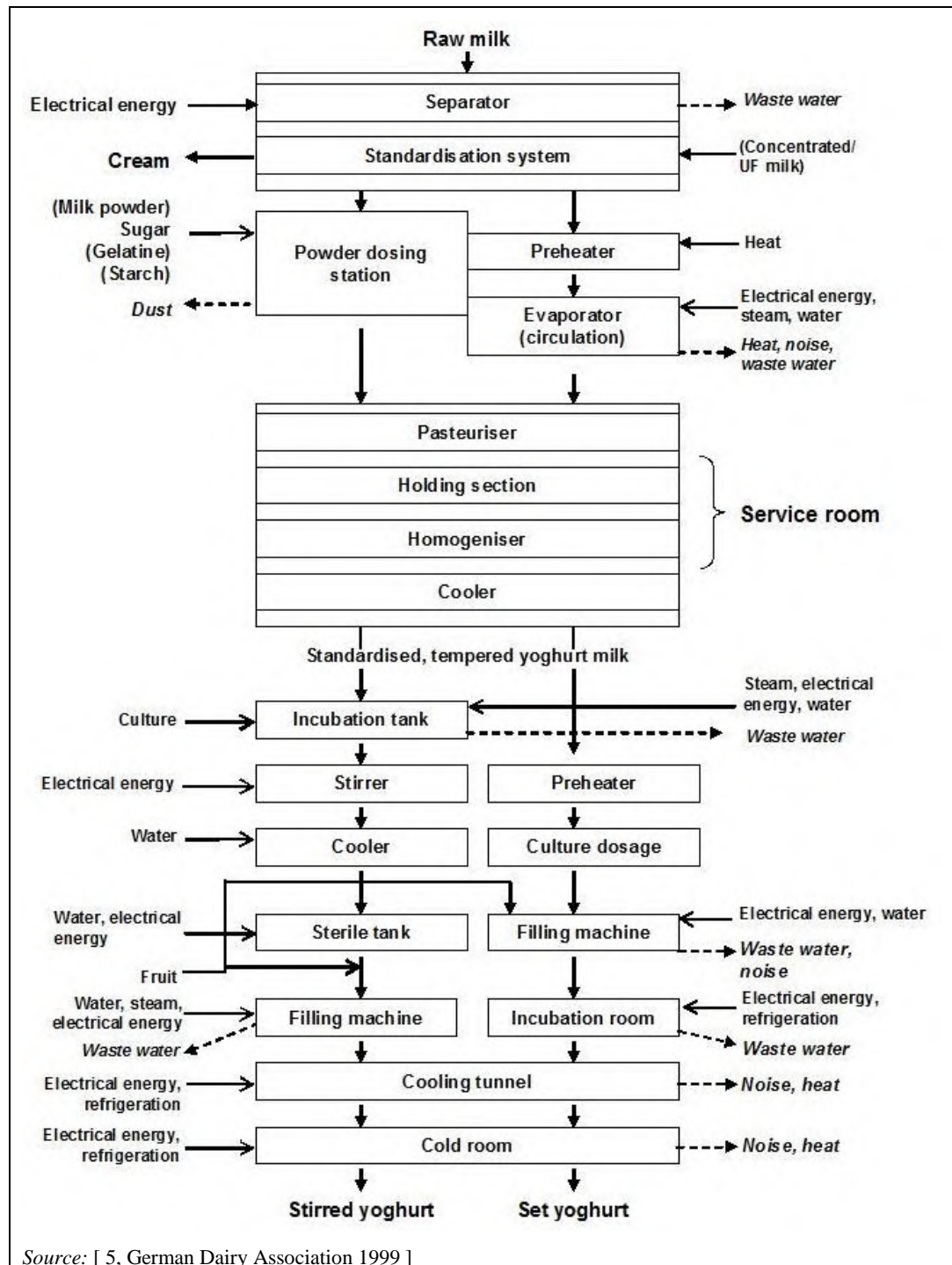

Figure 5.11: Yoghurt production

5.2.6 Ice cream

Ice cream is a dairy-based product which typically contains 6–12 % fat, 7.5–1.5 % non-fat milk solids, and 13–18 % sugars. Stabilisers, emulsifiers, colours and flavours are also added. Sugar is usually added as sucrose, and the non-fat milk solids are usually from skimmed milk solids. The fat source may be milk, cream, butter or butter oil. Most ice cream contains vegetable fat. The ingredients are blended, heated to around 70–75 °C and homogenised. The mixture is then pasteurised by heating to 80–85 °C for 2 to 15 seconds before cooling and ageing by holding at chilled temperatures for 4 to 24 hours.

Colours and flavours are added at the ageing stage. Continuous freezers are used to rapidly freeze the ice cream down to around -6 °C, with compressed air being introduced into the ice cream during the freezing process. The increase in volume due to the addition of air is known as over-run. The ice cream is filled into containers and frozen further in tunnel freezers operating at -30 °C to -40 °C.

5.2.7 Whey

In cheese manufacturing, about 90 % of the milk used ends up as whey. Whey is still seen as a valuable feed material, particularly amongst small producers. However, the development of the need for functional proteins in the human food industry has seen the increasing clarification, purification and fractionation of whey produced by the dairy industry for a variety of different human food purposes. Typically this can involve a variety of technologies, such as ultrafiltration, nanofiltration, reverse osmosis, and crystallisation, as well as thermal, ultraviolet, ultrasonic or microwave pasteurisation techniques.

After separation of cheese curd and whey, the cheese fines and the residual fat are removed from whey and it is pasteurised. Whey is usually concentrated before further processing and this can be done by RO, nanofiltration, evaporation or a combination of these. In the manufacture of standard whey powder, the whey is concentrated to a total solids content of about 60 % before drying in a spray dryer.

In the manufacture of whey protein concentrates, whey proteins and other components of whey are separated by ultrafiltration. The recovered protein fraction is concentrated further by evaporation before drying in a spray dryer. The powder is treated on a fluidised bed before packaging. Lactose can be recovered directly from concentrated whey or from concentrated residues from whey ultrafiltration. Lactose is crystallised and crystals are separated using centrifugation followed by drying in a spray dryer. The remaining mother liquid can be dried or used as such as animal feed. The high salt content of whey limits its use for human consumption. By removing the salts totally or partially in a demineralisation process, the range of applications of whey products can be broadened. The demineralisation can be achieved using nanofiltration, electrolysis, ion exchange or a combination of these. The electrolysis is based on the transport of ions through special membranes under the force of a direct electric current. Nanofiltration is suitable for lower degrees of demineralisation (20–30 %), electrolysis for ambient levels (up to 70 %) and ion exchange for high degrees (up to 90 %). After demineralisation the product is concentrated by the evaporator and dried, then treated on a fluidised bed and packed.

Whey protein concentrates and demineralised whey powders are normally used as raw materials in the food industry, in the manufacturing of clinical nutritional products and in infant foods.

5.2.8 Cleaning procedures in the dairy industry

5.2.8.1 Cleaning with chemicals

Processing equipment and production facilities should be cleaned and disinfected within fixed intervals according to the hygienic needs of the dairy industry. This cleaning process aims to remove soils and bacterial contamination from former production cycles. Hence, cleaning and disinfection processes are essential steps to provide product quality and consumer safety [210, EDA 2016].

5.2.8.1.1 General approach

Every cleaning procedure aims to remove soils deriving from foregoing production steps to guarantee soil- and bacteria-free products in the next production cycle. This procedure of cleaning-in-place (CIP) is today commonly water-based.

Most common in the dairy industry is the use of cycled alkaline (caustic) and acid washing to remove soils from production equipment. Therefore, sodium hydroxide in concentrations between 1 % and 5 % is used as an example. This washing step aims to remove proteins and other organic soils. To enhance the cleaning effect and soil removal, combinations of sodium hydroxide solutions and complexing or chelating compounds have been developed. These additional compounds are responsible for removal of, for example, co-factors of enzymes needed for bacterial augmentation. Commonly, EDTA salts are added to the alkaline solution to increase the cleaning effect. As a consequence of the caustic cleaning procedure, a mineral scale is left by the contact of alkaline solutions with metal surfaces. To remove this scale, nitric acid solutions are commonly used after the alkaline washing step. This acid washing step may also include the use of additional ingredients and sanitisers to reduce the load of, for example, bacterial contamination.

The effectiveness of the alkaline-acid washing procedure is remarkably influenced by the quality of the water used. Typically, hard water is less effective in cleaning procedures. Hence, the use of softened water can improve cleaning efficiency. This includes the use of water that shows maximum removal capacity for all organic residues, such as fat, oil, carbohydrates and proteins. Each of these compounds has an individual solubility in aqueous solutions. This solubility can be influenced by pH, temperature, dissolved salts (water hardness) and added compounds, detergents and sanitisers. How the optimal aqueous solutions should be assembled is case-dependent. In the case of dairy installations, the focus of the cleaning should rely on the removal of fat, proteins and microbial contamination. Hence, a mixture of caustic, detergent and sanitising compounds should be added to the aqueous solution. Furthermore, the mixture should be improved with respect to the individual needs of each dairy installation.

5.2.8.1.2 Dairy soils and the selection of the right cleaning chemicals

In dairies, surfaces are mainly soiled by fat, proteins and microbial load. The ratio in which each of these contaminants is present in the soil on production facilities is dependent on which product is processed and generated by the installation. Therefore, the optimal cleaning chemical composition should be selected individually for each case.

Proteins are a heterogeneous group of soil compounds in the dairy industry. Their solubility in aqueous solutions is remarkably dependent on the temperature and pH level of the solution. Protein solubility can be increased by alkaline lysis of the protein with sodium or potassium hydroxide.

Fats and oils from dairy produce are insoluble in water and are inert to alkaline lysis. Hence, surfactants can be added to remove fatty compounds. An alternative way to dissolve dairy soils

may be the use of enzymes. A common disadvantage of this alternative may be that enzymes are to be inactivated by alkaline or acid conditions which results in an additional cleaning step and hence increased costs of cleaning.

The microbial load also has to be reduced within the cleaning procedure. Disinfection can be realised by a broad range of substances with different properties regarding killing effectiveness, stability in aqueous solutions, biodegradability and material corrosivity. Commonly used substances are sodium hypochlorite or peroxyacetic acid. Each substance shows individual disinfection properties. For example, sodium hypochlorite has good rinsing characteristics but can show toxic effects depending on the environmental fate. This aspect is better respected by the use of peroxides.

5.2.8.1.3 Biocides

Biocides may be used to lower the microbiological load of dairy facilities. However, the use of biocides is regulated by different countries individually and attention should be paid to individual maximum residue levels and environmental aspects.

All biocides aim to affect the cell structure of microorganisms to prevent their replication within dairy installations. A distinction can be made between oxidising and non-oxidising biocides and UV radiation. Biocides typically used in the dairy industry include (minimum toxic effects):

- 2,2-dibromo-3-nitropropionamide (15 mg/kg);
- methylenebisthiocyanate (4 mg/kg);
- quarternary ammonium compounds (substance-dependent);
- 2-bromo-2-nitropropane-1,3-diol (254 mg/kg);
- isothiazolones (substance-dependent);
- tetra-(hydroxymethyl)-phosphonium sulphate (no toxicity observed in rats);
- peracetic acid (1 540 mg/kg);
- glutaraldehyde (1.3 mg/kg);
- sodium hypochlorite (1–5 mg/kg).

5.2.8.2 CIP procedures

Cleaning-in-place (CIP) is the most common cleaning procedure used in industrial production of food and beverages. The dairy industry in particular has to use CIP procedures due to the impossibility of simple disassembly, cleaning and reassembly of big industrial facilities. Therefore, trustworthy CIP procedures have to be used to guarantee the quality of dairy products and safety of consumers and producers.

Which special efforts should be made in CIP procedures in the dairy industry is very dependent on the type of soil derived from daily production. Furthermore, adherence of soil is determined by different physical forces (e.g. van der Waals forces, electrostatic forces or mechanical forces), which exerts additional limitations on the choice of CIP technique.

Another aspect which has to be respected when thinking about cleaning strategy is the process equipment to be cleaned, which consists of an individual sequence of pipes, tubes, barrels and other containers. Different types of steel show differing tolerances against acids and caustic substances, which also influences the choice of chemistry used in the CIP. Furthermore, if the production process involves polymeric substances, not all organic cleaning ingredients may be suitable as these compounds may be able to dissolve the polymeric materials.

5.3 Current consumption and emission levels

5.3.1 Energy consumption

Dairies have a significant energy consumption. Around 80 % of the energy is consumed as thermal energy from the combustion of fossil fuels to generate steam and hot water. It is used for heating operations and cleaning. The remaining 20 % is consumed as electricity to drive machinery, refrigeration, ventilation and lighting. The most energy-consuming operations are the evaporation and drying of milk [21, Nordic Council of Ministers 2001]. In pasteurisation for example, significant energy is also needed for the heating and cooling steps. Recovery of heat by heat exchangers can be applied. Evaporation is normally combined with vapour recompression.

A wide range of energy consumption data has been reported for the European dairy industry. Figure 5.12, Figure 5.13, Figure 5.14 and Figure 5.15 show reported data on overall specific energy consumption in dairies according to the main product (market milk, cheese, powder, fermented milk); the main product in these figures refers to at least 80 % of the production.

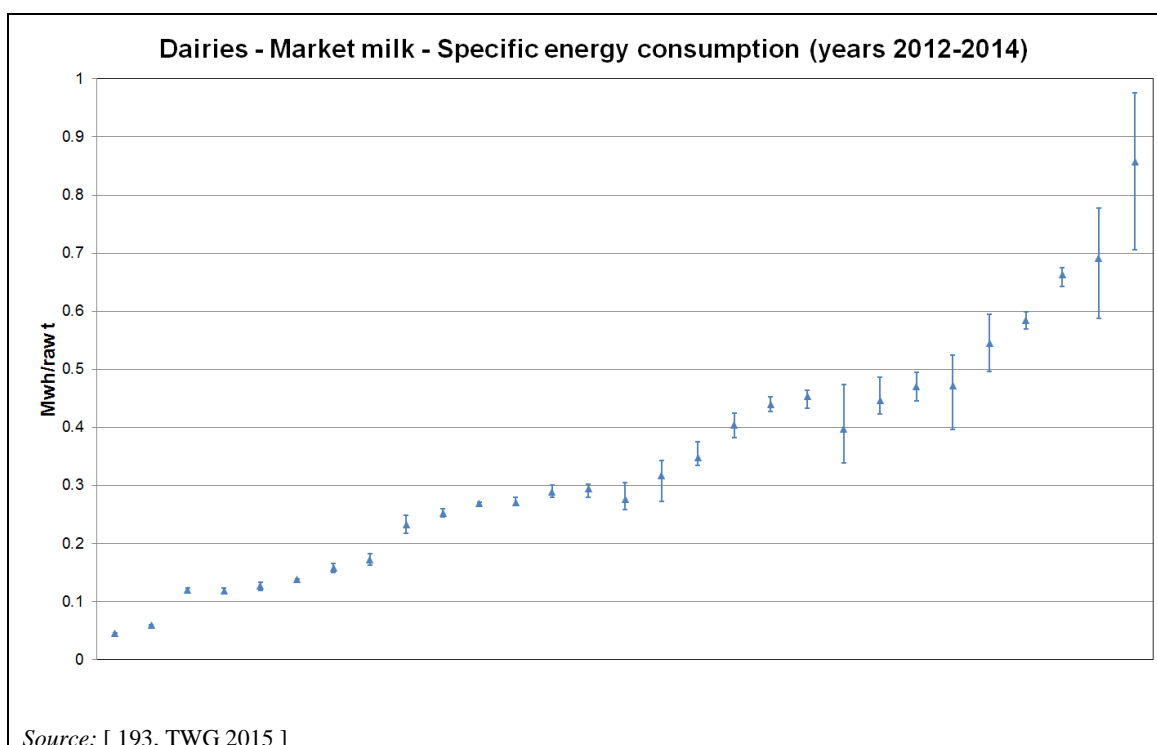

Figure 5.12: Specific energy consumption (MWh/tonne of raw materials) in production of market milk

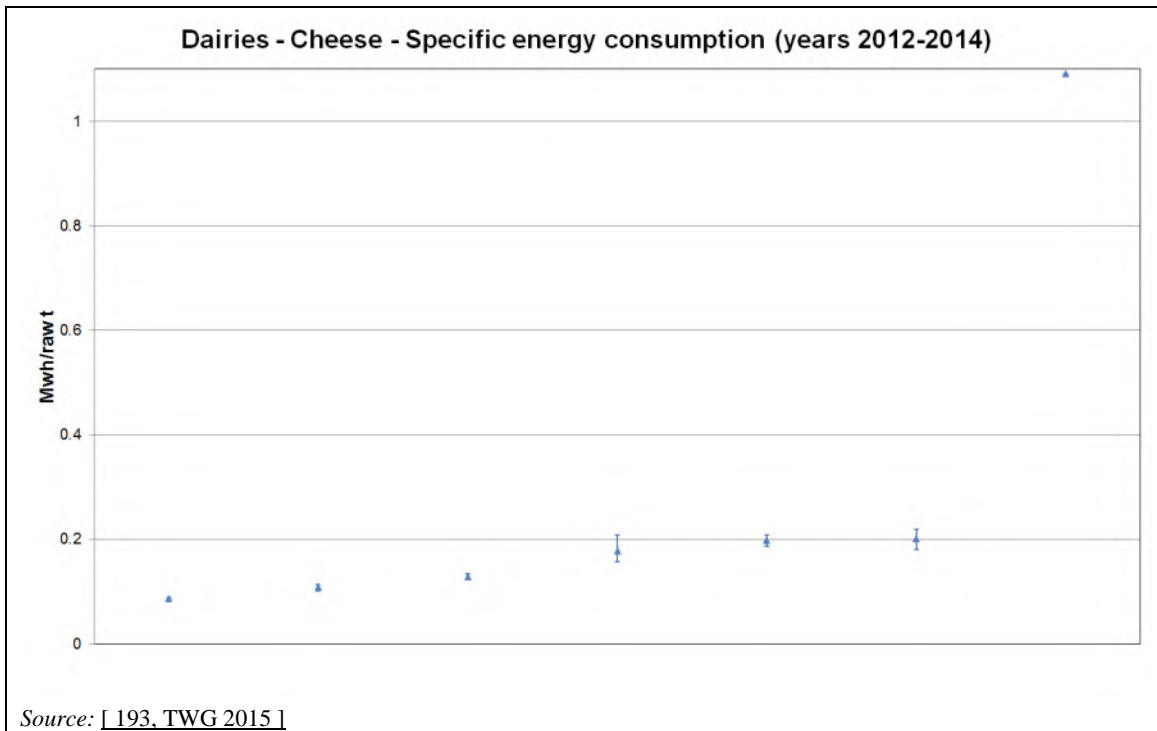

Figure 5.13: Specific energy consumption (MWh/tonne of raw materials) in production of cheese

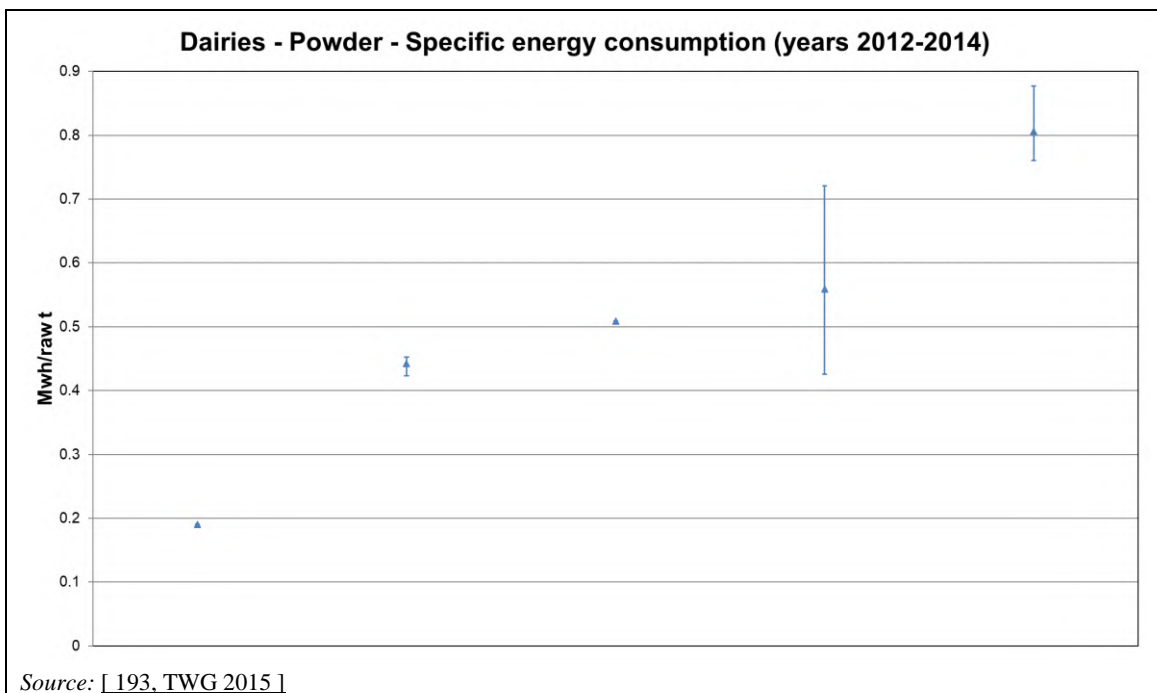

Figure 5.14: Specific energy consumption (MWh/tonne of raw materials) in production of powder

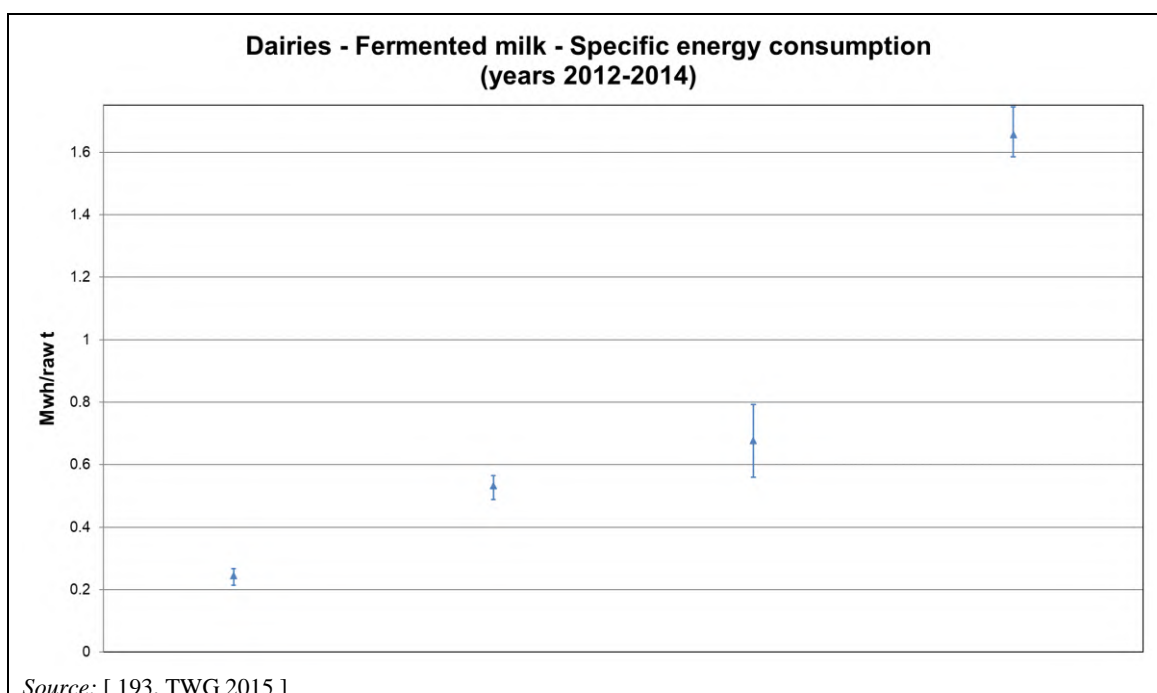

Figure 5.15: Specific energy consumption (MWh/tonne of raw materials) in production of fermented milk

More energy is used in dairies where butter, as well as drinking milk, is produced and where the production of powdered milk is greater.

5.3.2 Water consumption

Water consumption is mainly associated with cleaning operations. The factors affecting water consumption in European dairies are [89, EDA 2002]:

- availability of surface and groundwater for cooling;
- time and amount of water used for rinsing;
- characteristics of CIP programmes;
- maintenance, e.g. repair of leaks.

Table 5.1 shows the reported water consumption in European dairies.

Table 5.1: Water consumption in European dairies (years 2012-2014)

Product	Water consumption (m ³ /tonne of raw materials)
Market milk	0.33–12.61
Cheese	0.24–4.90
Powder (e.g. milk, whey)	0.50–4.27
Fermented milk	1.91–17.23

Source: [193, TWG 2015]

5.3.3 Solid output

The characteristics of dairy solid outputs may vary significantly, depending on the final products, system type and operation methods used in the manufacturing plant. The solid and liquid wastes are mainly composed of different types of primary, secondary and tertiary packaging, servicing and testing materials, lubrication fluids, and waste consumables. Depending on the integration of the dairy facility, these may include either upstream wastes (from farming operations) or downstream wastes (from logistics and warehousing operations).

Dairy wastes are produced at many stages of the operations, from primary processing and separation of milk, through to production, packing and distribution of the final products. They can be liquid, semi-solid, solid, or diluted with water (as interfaces); unless discharged to the WWTP, they are collected in tanks or silos if liquid, but also in various containers and/or palletised if solid. Most dairy food waste is also governed by food and feed legislation, particularly the Animal By-Products Directive [99, EC 2002].

The solid wastes are, on the whole, mainly packaging-related. The type of packaging varies significantly across Europe depending on both the primary container (which can range from multilayered cardboard through to a wide variety of plastics) and the type of retailing systems used in the different Member States from small shops to very large supermarkets. Volumes of dairy wastes and their constituents differ over time. They are affected by the production profile of the plant which is usually made up of a sequence of periodic processes.

A typical process flow chart of food wastes from a typical dairy is shown in Figure 5.16.

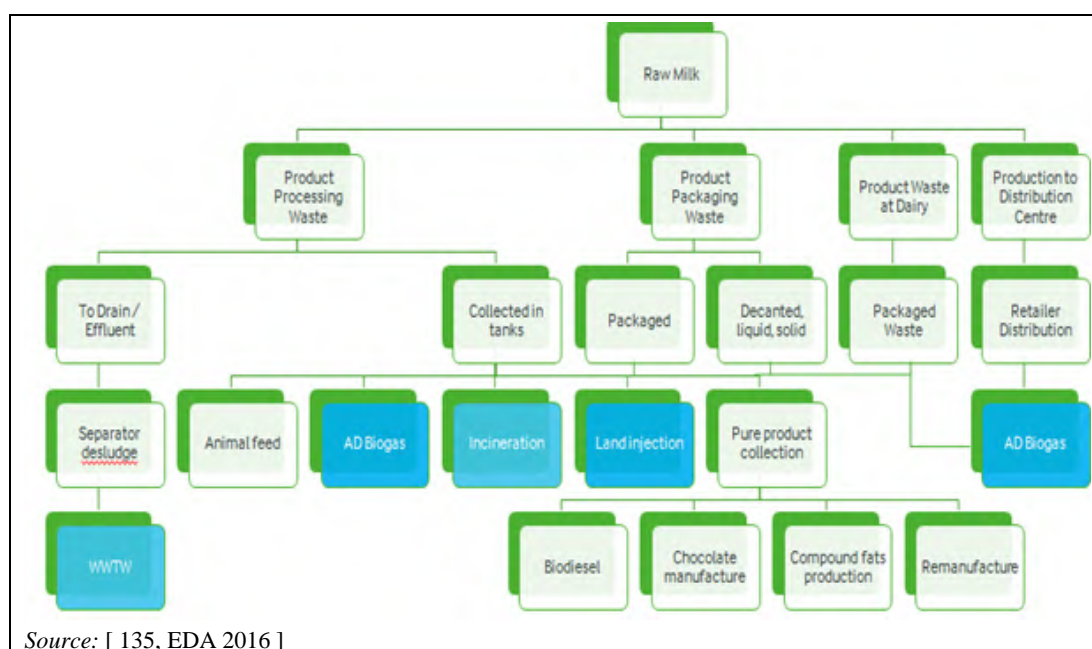

Figure 5.16: Flow chart of food waste in a typical dairy

Liquid waste –in the blue boxes in Figure 5.16– is treated using traditional types of waste water treatment, anaerobic digestion or landspreading. A final waste solution is to incinerate and this may be done if the dairy waste falls into Category 2 of the Animal By-Products Directive (contaminated with a foreign substance, such that it is unsuitable for human or animal consumption).

Dairy operators are increasingly finding ways in which to reprocess dairy food surpluses and by-products (e.g. whey, see Section 5.2.7) into other food, animal feed or energy materials.

Product losses in the dairy industry, expressed as a percentage of the volume of milk, fat or whey processed, are summarised in Table 5.2.

Table 5.2: Product losses in some processes in the dairy industry

Type of processing	Product losses (%)		
	Milk	Fat	Whey
Butter/transport of skimmed milk	0.17	0.14	–
Butter and skimmed milk powder	0.60	0.20	–
Cheese	0.20	0.10	1.6
Cheese and whey evaporation	0.20	0.10	2.2
Cheese and whey powder	0.20	0.10	2.3
Consumer milk	1.9	0.7	–
Full-cream milk powder	0.64	0.22	–

Source: [74, World Bank (IBRD) et al. 1998]

Reported solid outputs per tonne of processed milk are shown in Table 5.3.

Table 5.3: Solid output per tonne of processed milk

Type of processing	Solid output (kg)	WWTP sludges (kg)
Liquid milk and yoghurt	1.7–45.0	0.2–18.0
Cheese	1–20	0.2–24
Milk and whey powder	0.5–16	3–30

Source: [89, European Dairy Association 2002]

Product loss during milk manufacture can be as high as 3–4 %, with normally 0.5–1.5 % of the product being wasted. These milk losses can occur during cleaning; the run-off during the start-up, shutdown or changeover of an HTST unit; or from accidental spills. Product losses to waste water can contribute greatly to the COD, nitrogen and phosphorus content. Typical milk losses are shown in Figure 5.17.

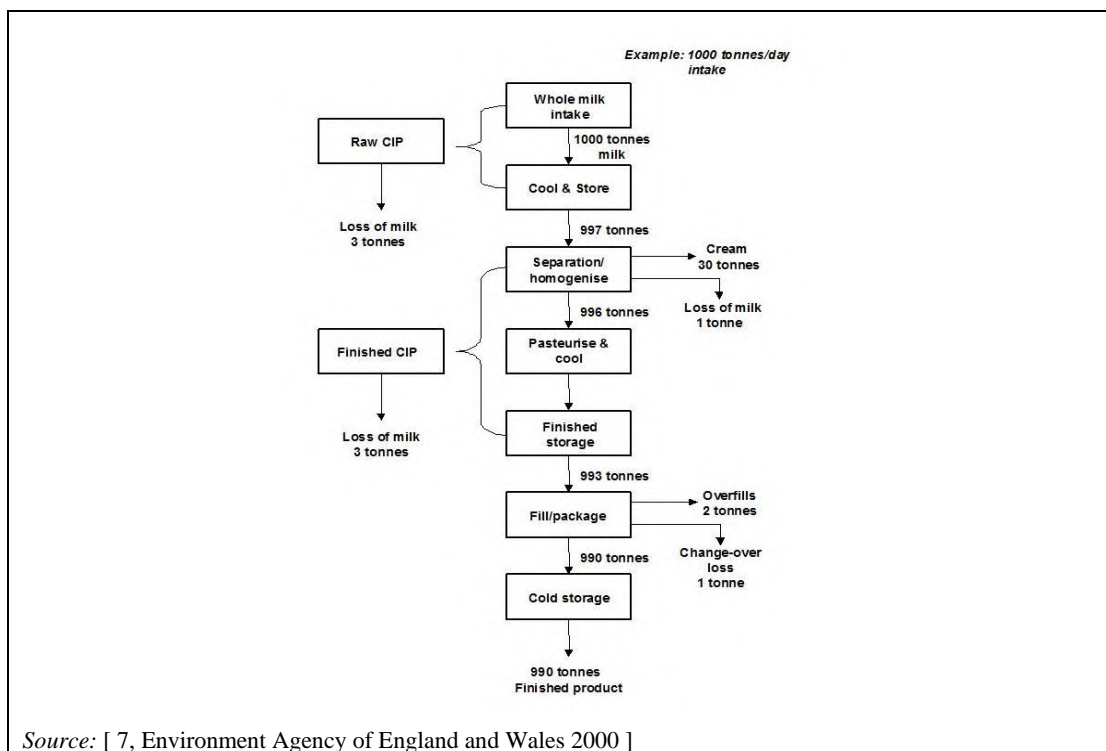

Figure 5.17: Typical losses of milk in the dairy industry

The overall solid output for ice cream manufacturing reported for Europe is in a wider range, i.e. 30–150 kg/t of product [65, CIAA-EDA 2002].

5.3.4 Emissions to water

Waste water is the main environmental issue in the dairy sector. The sector uses a vast amount of water and generates a huge amount of waste water in maintaining the required level of hygiene and cleanliness.

Figure 5.18, Figure 5.19 and Figure 5.20 show reported data on specific waste water discharge flows in European dairies according to the main product (market milk, cheese, powder) and for all types of discharges); the main product in these figures refers to at least 80 % of the production. More information on emissions to water can be found in Section 2.2.3.

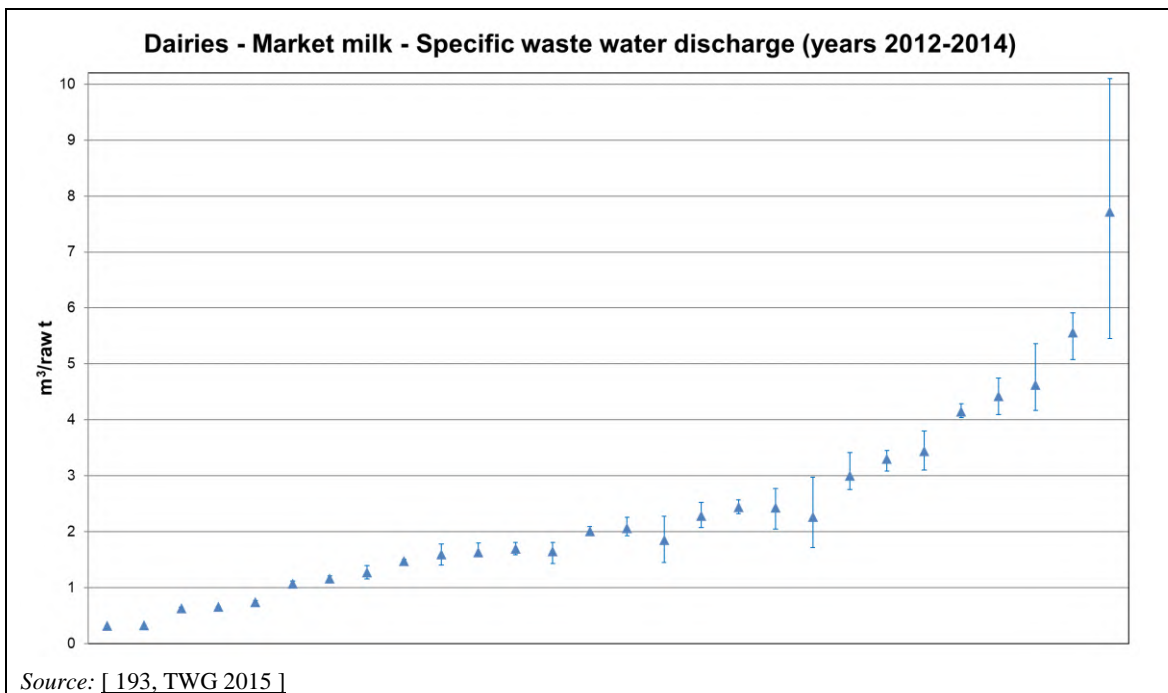

Figure 5.18: Specific waste water discharge (m^3/tonne of raw materials) in production of market milk

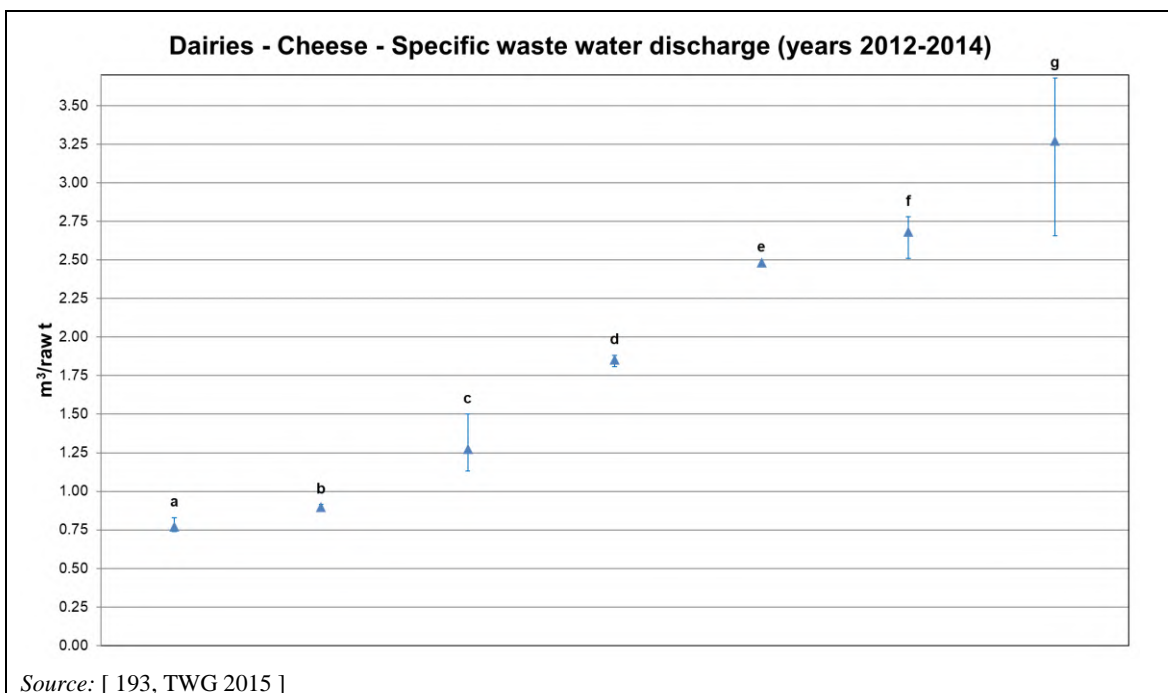

Figure 5.19: Specific waste water discharge (m^3/tonne of raw materials) in production of cheese

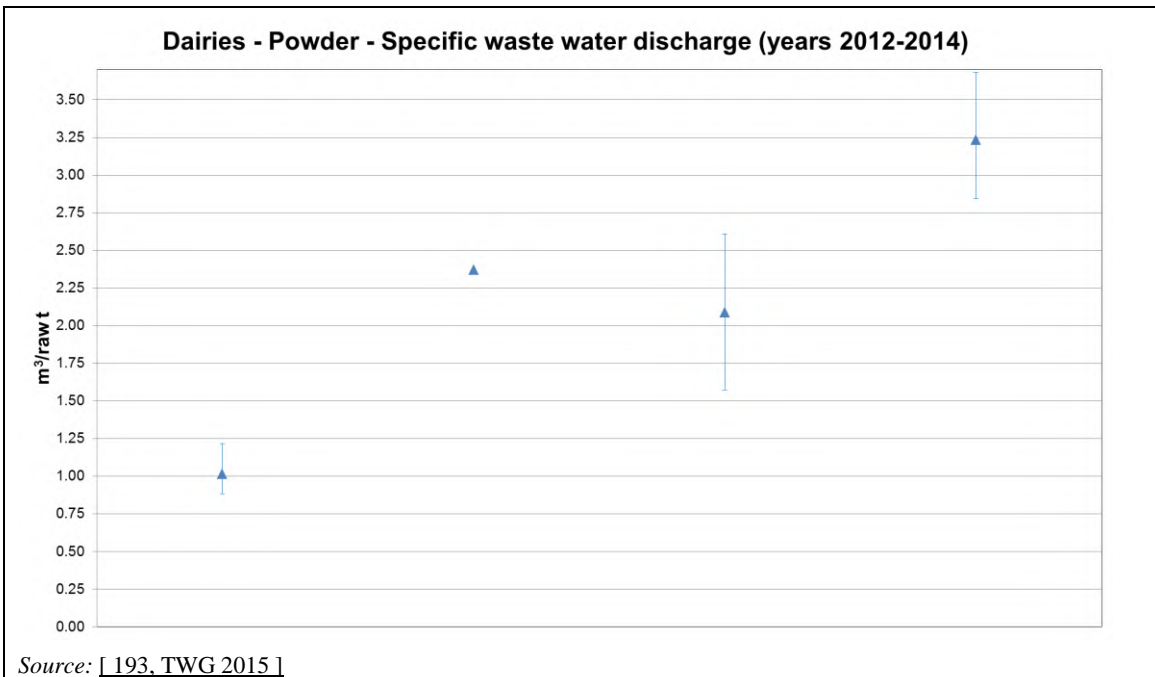

Figure 5.20: Specific waste water discharge (m³/tonne of raw materials) in production of powder

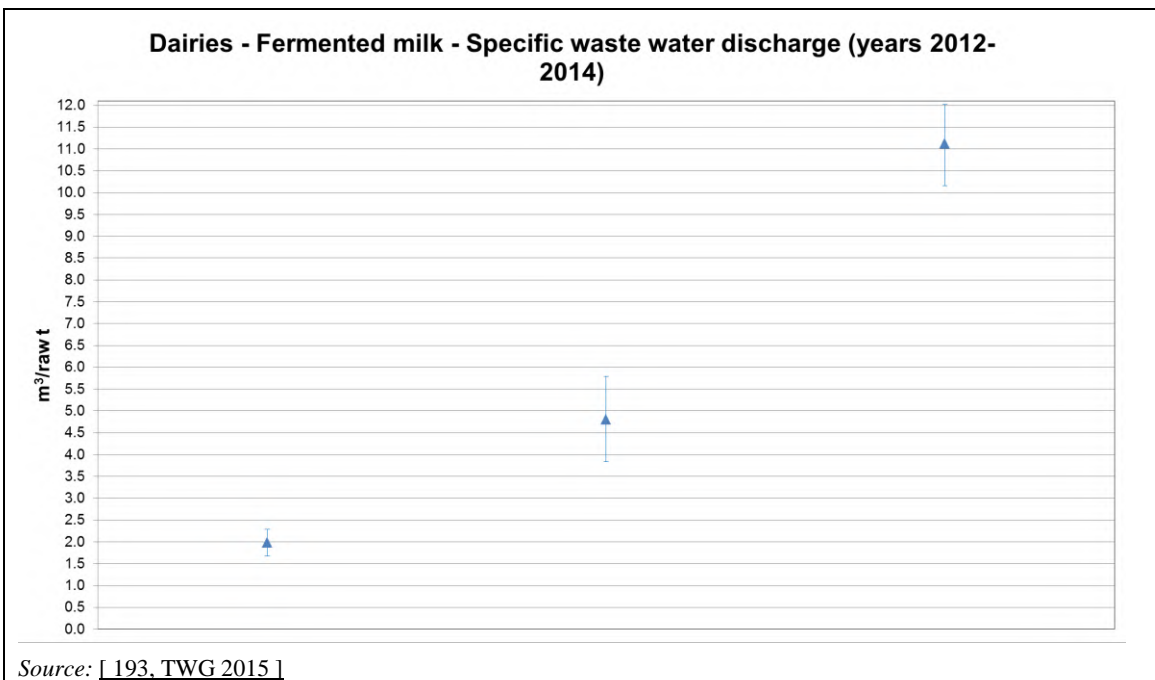

Figure 5.21: Specific waste water discharge (m³/tonne of raw materials) in production of fermented milk

5.3.5 Emissions to air

5.3.5.1 Dust emissions from dryers

A general overview of the data received for dust emissions from dryers is shown in Figure 5.22 (lower values) and Figure 5.23 (higher values). The applied end-of-pipe abatement techniques are also indicated.

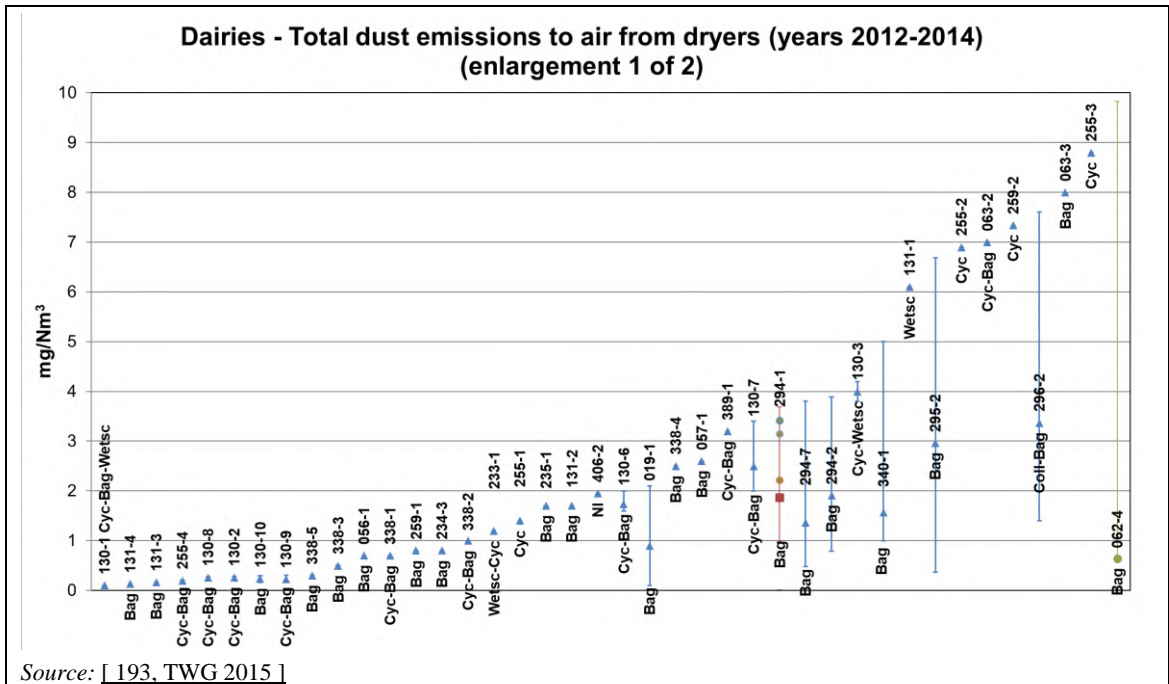

Figure 5.22: Total dust emissions to air from dryers (1 of 2)

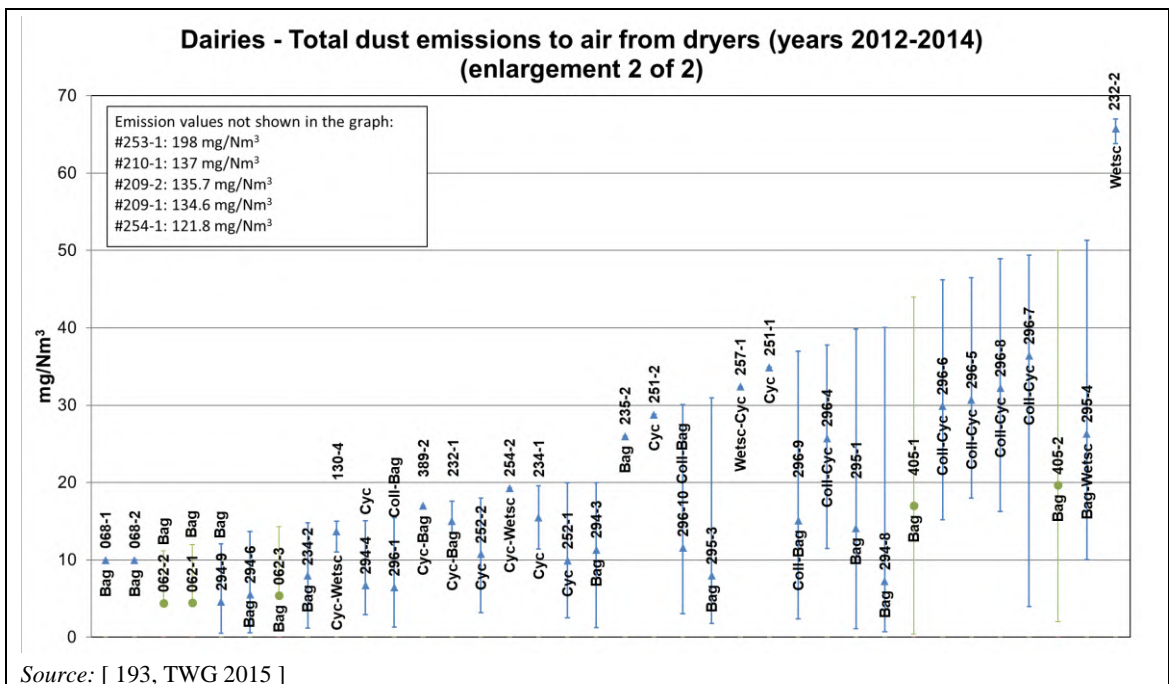

Figure 5.23: Total dust emissions to air from dryers (2 of 2)

The meaning of the symbols and abbreviations used in Figure 5.22 and Figure 5.23 are indicated in Table 3.3 and Table 3.4.

Bag filters (mainly of the tubular type), cyclones and wet scrubbers are used as final abatement techniques for dust emissions from dryers. The combination of cyclones and bag filters is also a commonly implemented treatment. Generally, bag filters are associated with the lowest achieved dust emission levels. The O₂ content (%) in the emissions flow is often not reported, but from the received data it is assumed that most dryers operate close to atmospheric O₂ levels.

5.3.6 Consumption of chemicals

Most of the chemicals used are used for the cleaning and disinfection of process machinery and pipelines. Fresh product dairies mainly use caustic and nitric acid and some disinfectants, such as hydrogen peroxide, peracetic acid and sodium hypochlorite. Disinfection agents are also used in a range of 0.01–0.34 kg/t of processed milk [160, European Dairy Association, 2002]. Table 5.4 shows the consumption of cleaning agents used in European dairies.

Table 5.4: Consumption of cleaning agents used in European dairies

Products	Consumption of cleaning agents (kg/t processed milk)		
	NaOH, 100 %	HNO ₃ , 100 %	Detergents
Market milk and yoghurt	0.2–10	0.2–5.0	*
Cheese	0.4–5.4	0.6–3.8	0.1–1.5
Milk and whey powder	0.4–5.4	0.8–2.5	*
NB: Values vary with the length and capacity of production runs. * Not applicable. Source: [89, EDA 2002]			

Whey processing involving electrolysis, ion exchange, ultra and nanofiltration requires large amounts of phosphoric, sulphuric and hydrochloride acid as well as potassium hydroxide and sodium hypochlorite.

5.4 Techniques to consider in the determination of BAT

5.4.1 General environmental performance

5.4.1.1 Reduction of EDTA use by minimising milk fouling and milkstone formation by production planning

Description

Production planning to prevent milk fouling and milkstone build-up and the consequent use of EDTA.

Technical description

Milk fouling and milkstone formation can be reduced by using milk with high protein stability. The stability of milk protein is reduced by repeated processing and pumping. Production planning to prevent reprocessing can, therefore, contribute to the prevention of milkstone build-up and the consequent use of EDTA. Milk fouling and milkstone formation are also higher if the milk has a high microorganism count, so can be reduced if adequate hygiene conditions are enforced. There are a number of other factors which cause protein instability in milk, such as enzyme activity.

Achieved environmental benefits

Optimal use of milk and reduced EDTA and energy consumption.

Environmental performance and operational data

By optimising the milk processing time and using good-quality raw milk, in which proteins have high heat stability, milk fouling and the formation of milkstone can be reduced. The milk fouling and milkstone reduce the efficiency of the heat exchange and the flow rate, especially in plate heat exchangers. Consequently, indirect heat exchangers have to be cleaned no more than 8–9 hours after start-up. Longer times between cleaning may cause a build-up of milk fouling and milkstone which is more difficult to remove. A differential pressure gauge can be used to monitor the pressure drop between the processor inlet and outlet to judge when the equipment needs to be cleaned. Low milk quality affects the running time because the heat stability of the proteins is reduced and they precipitate more easily on the surfaces.

The heat stability of milk may be checked by heating the milk to its boiling point and evaluating the amount of sediment produced or by a simple test carried out by mixing milk and ethanol and checking if any precipitation occurs on glass surfaces. More stable proteins require higher concentrations of ethanol for precipitation to occur.

The milk stability also determines the products which milk can be used to make. For example, milk containing higher-stability proteins is required for drinking milk rather than for cheesemaking.

Cross-media effects

There are no cross-media effects associated with this technique.

Technical considerations relevant to applicability

Applicable in all dairies.

Economics

No information provided.

Driving force for implementation

Reduction of energy and waste water treatment costs.

Example plants

No information provided.

Reference literature

[150, Barale M. 2004]

5.4.1.2 Use of computer-controlled milk transfer, pasteurisation, homogenisation and CIP equipment

Description

Use of computerised processes in dairies.

Technical description

An example dairy installation receives 450 000 litres of milk. The installation requires its suppliers to use mechanical milking, have proper refrigeration capacity and to apply HACCP. The flow sheet for the processing in the installation is illustrated in Figure 5.24.

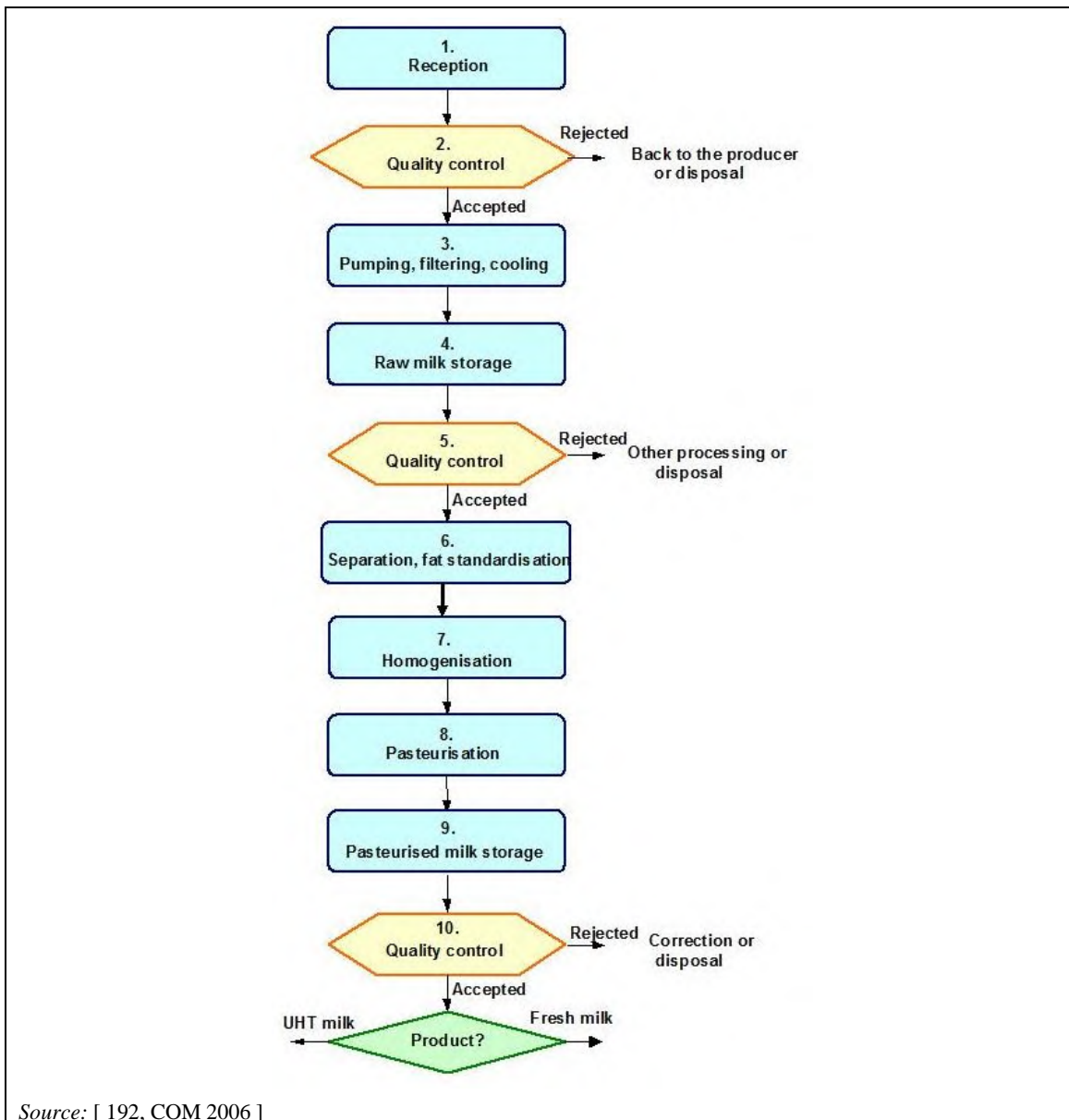

Figure 5.24: Processing flow sheet for a dairy producing milk

The milk reception is via two parallel programmable logic control closed systems. The introduction of a technique using special valves has significantly reduced the milk losses. It is reported that where the valves have been introduced, milk losses during transfer between pipes,

when filling tanks and due to human errors have been totally eliminated, thus waste water pollution from that source has decreased.

The milk is also pasteurised by computer-controlled plate heat exchangers, which have a greater surface area for heat exchange than others and are equipped with automatic fat-standardising and homogenising units.

The processing is carried out in a closed system. The control for storing and pumping the raw materials, intermediaries and products to the different processing units of the installation is carried out by a computer-aided system. The losses have been minimised by using this system. The same control system operates the CIP system. Here, the last rinsing water is used for the next cleaning cycle.

In another example, the programming of chained sending of product to pasteurisation is implemented. While a product is being pasteurised, the next sending is programmed; so the standby step is removed.

Achieved environmental benefits

Reduced milk wastage and waste water contamination. The computerised CIP system also leads to reduced water and reagent savings.

Environmental performance and operational data

During pasteurisation, the greater surface area for heat exchange and the recirculation of warm water reportedly results in about 25 % savings in energy consumption and about 50 % savings in water consumption, in comparison with the old pasteurisers.

The computerised process control avoids or decreases milk losses in reception and during further processing. The automatic dosing reportedly results in about 15 % savings both in water and in the consumption of cleaning and disinfecting agents.

Cross-media effects

No information provided.

Technical considerations relevant to applicability

This technique is applicable in new and existing installations. Increased yield is gained, and time is saved during this process.

Economics

Investment costs are high.

Driving force for implementation

Reduced costs for energy and water.

Example plants

Dairies in Hungary and Spain [193, TWG 2015].

Reference literature

[81, Sole 2003], [192, COM 2006], [193, TWG 2015], [226, EDA 2016]

5.4.2 Techniques to increase energy efficiency

5.4.2.1 Partial milk homogenisation

Description

The cream is homogenised together with a small proportion of skimmed milk. The size of the homogeniser can be significantly reduced, leading to energy savings.

Technical description

Cream is homogenised together with a small proportion of skimmed milk. The optimum fat content of the mixture is 12 %. The rest of the skimmed milk flows directly from the centrifugal separator to the pasteurisation section of the pasteuriser. The homogenised cream is remixed into the skimmed milk stream before it enters the final heating section. Using this technique, the size of the homogeniser can be significantly reduced, leading to energy savings.

Achieved environmental benefits

Reduced energy consumption.

Environmental performance and operational data

In an example dairy, the introduction of partial homogenisation into a pasteurisation line with a nominal capacity of 25 000 l/h led to a reduction in the homogenisation capacity to 8 500 l/h. The total electrical power was reduced by about 65 % by installing a smaller homogeniser of 55 kW.

Cross-media effects

No information provided.

Technical considerations relevant to applicability

Applicable in dairies.

Economics

Smaller homogenisers are cheaper in terms of investment costs and operational costs. The price of the smaller homogeniser is about 55 % of the price of a piece of equipment with the ability to treat the nominal capacity of the line.

Driving force for implementation

Lower investment and energy costs.

Example plants

It is widely used in modern dairies.

Reference literature

[21, Nordic Council of Ministers 2001]

5.4.2.2 Energy-efficient homogeniser

Description

The homogeniser's working pressure is reduced through optimised design and thus the associated electrical energy needed to drive the system is also reduced.

Technical description

This technique allows the pressure to be reduced while maintaining the homogenisation effect. The energy needed to drive a conventional homogeniser is proportional to the pressure at which the system runs in order to reduce the fat globule size sufficiently. The homogeniser working pressure can be reduced (through innovations in the design of the homogenisation device), and the associated electrical energy needed to drive the system can then be reduced.

Achieved environmental benefits

Reduced electricity consumption.

Environmental performance and operational data

With a homogeniser with an efficient design, electricity consumption can be reduced by about 30 % (see Table 5.5). Electric energy consumption can in such cases be reduced by an additional 15–33 % (savings increase with higher capacity).

Table 5.5: Comparison between two different homogenisation devices

	Conventional design (¹)	Efficient design	Advanced design (²)
Homogenisation pressure (bar)	200	135	97
Electric power needed (kW)	151	104	75
Electricity use per year (kWh/yr)	724 000	499 100	360 900
Electricity cost per year (EUR)	72 400	49 910	36 090
⁽¹⁾ Conditions: homogeniser capacity 25 000 l/h; desired homogenisation effect 75 % NIZO; production time 4 800 h/year; electricity price EUR 0.1/kWh. ⁽²⁾ The advanced design is only applicable to homogenisation of milk at capacities of 15 000 l/h or more. <i>Source: [182, Tetra Pak 2015]</i>			

Cross-media effects

No information provided.

Technical considerations relevant to applicability

The technique is applicable to high-pressure homogenisation of emulsions and suspensions, aseptic or non-aseptic high- or low-viscous products, including pasteurised milk, UHT milk, cream, yoghurt, condensed milk, ice cream mix, fruit juices, concentrates, etc.

Economics

No information provided.

Driving force for implementation

- Reduced operational cost.
- A lower pressure also means less load on the homogeniser, so maintenance and worn parts' replacement intervals will be less frequent, which means reduced downtime.

Example plants

This technique is generally used in the EU-28 and in the world. For example, Arla Foods Holstebro in Denmark has implemented the advanced homogenisation device.

References

[182, Tetra Pak 2015]

5.4.2.3 Sterile water use in homogeniser**Description**

Flushing the aseptic barriers with sterilised water instead of steam.

Technical description

This technology for high-pressure aseptic homogenisers is based on flushing the aseptic barriers with sterilised water instead of steam. The sterile water at 50–60 °C is used on the plunger surface during the reciprocating movement and it allows the reduction of the friction and temperature between the seals and the plunger surface. The sterile water temperature is extremely relevant in order to extend the plunger seals' lifetime two or three times compared to pressurised steam barrier systems.

Cold water enters the regenerative plate heat exchanger and by a system of connectors arrives at the steam injector which overheats the water. The liquid thereafter reaches a holding tube where it remains for the sterilisation period. The liquid then returns to the regenerative plate exchanger, from which it started its cycle, though in the opposite direction and on the exchanger-cleaned side, where it cools down before reaching the homogenisation aseptic chambers.

Achieved environmental effects

Reduction of steam and water consumption. Water that was previously used in the heat exchanger for the condensation is now mixed with the steam.

Environmental performance and operational data

In an example dairy, the old typical system uses around 300 kg/h of steam condensed to 50 °C with raw water in a heat exchanger (usually with no heat or water recovery). With the implementation of this technique, a steam consumption level of 20 kg/h are estimated.

Cross-media effects

No information provided.

Technical considerations relevant to applicability

No information provided.

Economics

An investment cost of EUR 30 000 has been reported (for a homogeniser of 17 m³). The payback period is less than a year and a half.

Driving force for implementation

Improving the installation's energy efficiency.

Example plants

At least one installation in the EU.

Reference literature

[193, TWG 2015]

5.4.2.4 Use of continuous pasteurisers

Description

Flow-through heat exchangers are used (e.g. tubular, plate and frame). The pasteurisation time is much shorter than that of batch systems.

Technical description

In continuous pasteurisation, flow-through heat exchangers, e.g. tubular, plate and frame, are used. These have heating, holding and cooling sections. To reduce energy consumption and waste water generation, continuous pasteurisers are used instead of batch pasteurisers.

Achieved environmental benefits

Reduced energy consumption and waste water production, compared to batch pasteurisers.

Environmental performance and operational data

Batch-wise pasteurisation uses a temperature of 62–65 °C for up to 30 minutes. Continuous pasteurisers include high-temperature short-time pasteurisation (HTST) and high-heat short-time pasteurisation (HHST). HTST uses a temperature of 72–75 °C for 15 to 240 seconds. HHST applies a temperature of 85–90 °C for 1 to 25 seconds.

Cross-media effects

No information provided.

Technical considerations relevant to applicability

Applicable in dairies.

Economics

No information provided.

Driving force for implementation

Reduced energy and waste water treatment costs.

Example plants

No information provided.

Reference literature

[71, AWARENET 2002]

5.4.2.5 Regenerative heat exchange in pasteurisation**Description**

The incoming milk in the countercurrent flow is preheated by the hot milk leaving the pasteurisation section.

Technical description

Pasteurisers are normally equipped with some regenerative countercurrent flow heating sections. The incoming milk is preheated with the hot milk leaving the pasteurisation section.

Achieved environmental benefits

Reduced energy consumption.

Environmental performance and operational data

Typically energy savings over 90 % can be achieved. It is reported that, in an example dairy, by applying indirect heat exchange between the post-thermal-treatment product and the inlet product, the specific energy consumption of 148 000 kcal/t (619 232 kJ/t) can be reduced by 80 %, i.e. to 29 000 kcal/t (121 336 kJ/t). The reported temperatures of the process are as follows:

- initial temperature of 4 °C;
- regeneration heating temperature of 65 °C;
- pasteurisation temperature of 78 °C;
- regeneration cooling temperature of 20 °C;
- pasteurised milk temperature of 4 °C.

Also, heat exchangers have reportedly been applied in the dairy between the inlet cold product, i.e. cold milk, and the steam coming from the extraction during vacuum expansion after UHT treatment. The specific energy consumption of 251 000 kcal/t (1 050 184 kJ/t) can be reduced by 26 %, i.e. to 185 000 kcal/t (774 040 kJ/t). The reported temperatures of the process are as follows:

- initial milk temperature of 4 °C;
- regeneration heating temperature of 70 °C;
- UHT treatment temperature of 140 °C;
- UHT milk filling temperature of 25 °C.

Cross-media effects

No information provided.

Technical considerations relevant to applicability

It is widely applied in dairies. In older dairies, heating and cooling energy can be further reduced by replacing the old plate exchangers with more effective ones.

Economics

Reduction in energy costs. In an example installation, investment costs of around EUR 145 000 (with low operating costs) have been reported for the installation of a new heat exchanger in milk pasteurisation [193, TWG 2015].

Another reported example comes from a new dairy, where nine plate exchangers were installed with higher regenerative efficiencies. Calculations were made for increasing the efficiency from 85 % to 91 % or from 91 % to 95 %. Savings in heating energy of 2 712 MWh/yr and in electricity of 542 MWh/yr were estimated, with an investment cost of EUR 370 000 and a payback period of 3.6 years.

Driving force for implementation

Reduction in energy costs.

Example plants

Various dairies across the EU [193, TWG 2015].

Reference literature

[21, Nordic Council of Ministers 2001], [43, Italian contribution 2002], [193, TWG 2015].

5.4.2.6 Hibernation for pasteurisers and sterilisers

Description

The pasteuriser/steriliser unit is in hibernation mode during water circulation (for aseptic lines without losing the aseptic status).

Technical description

Often pasteurisers and sterilisers spend a significant amount of time in non-productive circulation. With the hibernation function, the pasteuriser/steriliser unit will go into hibernation mode during water circulation (for aseptic lines without losing the aseptic status). During this mode the flow rate decreases, the cooling is reduced to a minimum and the total energy consumption (steam, electricity and cooling water) will be reduced.

Achieved environmental benefits

With the hibernation mode, the unnecessary waste of energy is reduced when the pasteuriser/steriliser is in non-production circulation mode, e.g. waiting for raw material or for fillers to become available.

Environmental performance and operational data

A reduction in energy consumption of between 60 % and 85 % can be achieved during hibernation mode. An example of energy savings is shown in Table 5.6.

Table 5.6: Energy reduction in a UHT unit by applying hibernation

Milk treatment with UHT unit with direct steam injection ⁽¹⁾		
	With hibernation	Without hibernation
Steam consumption (kg/h)	1 350	2 250
Electricity consumption (kW/h)	8	35
Tower water (kW/h)	350	1 050
Steam reduction (kg/year)	540 000	NA
Electricity reduction (kw/year)	16 400	
⁽¹⁾ Capacity of UHT unit: 15 000 l/h. 2 h/day of water circulation, 300 days/year. NB: NA = not applicable. Source: [183, Tetra Pak 2015]		

Cross-media effects

No information provided.

Technical considerations relevant to applicability

Generally, there are no technical restrictions to the applicability of this technique in dairies.

Economics

No information provided.

Driving force for implementation

Reduced operating cost.

Example plants

This technique is generally used in the EU and worldwide.

References

[183, Tetra Pak 2015]

5.4.2.7 Ultra-high temperature process of milk without intermediate pasteurisation

Description

UHT milk is produced in one step from raw milk, thus avoiding the energy needed for pasteurisation.

Technical description

Cold raw milk, with fully crystallised fat, is preheated, separated, standardised to a predetermined fat content and homogenised. The milk is then heat-treated to UHT temperature before being cooled to ambient temperature and sent to aseptic buffer tanks. The process from raw milk to UHT milk is thus made up of one step, with substantial savings in energy, product losses and equipment by removal of the traditional pasteurisation step.

Figure 5.25 shows a comparison between this technique and the conventional process.

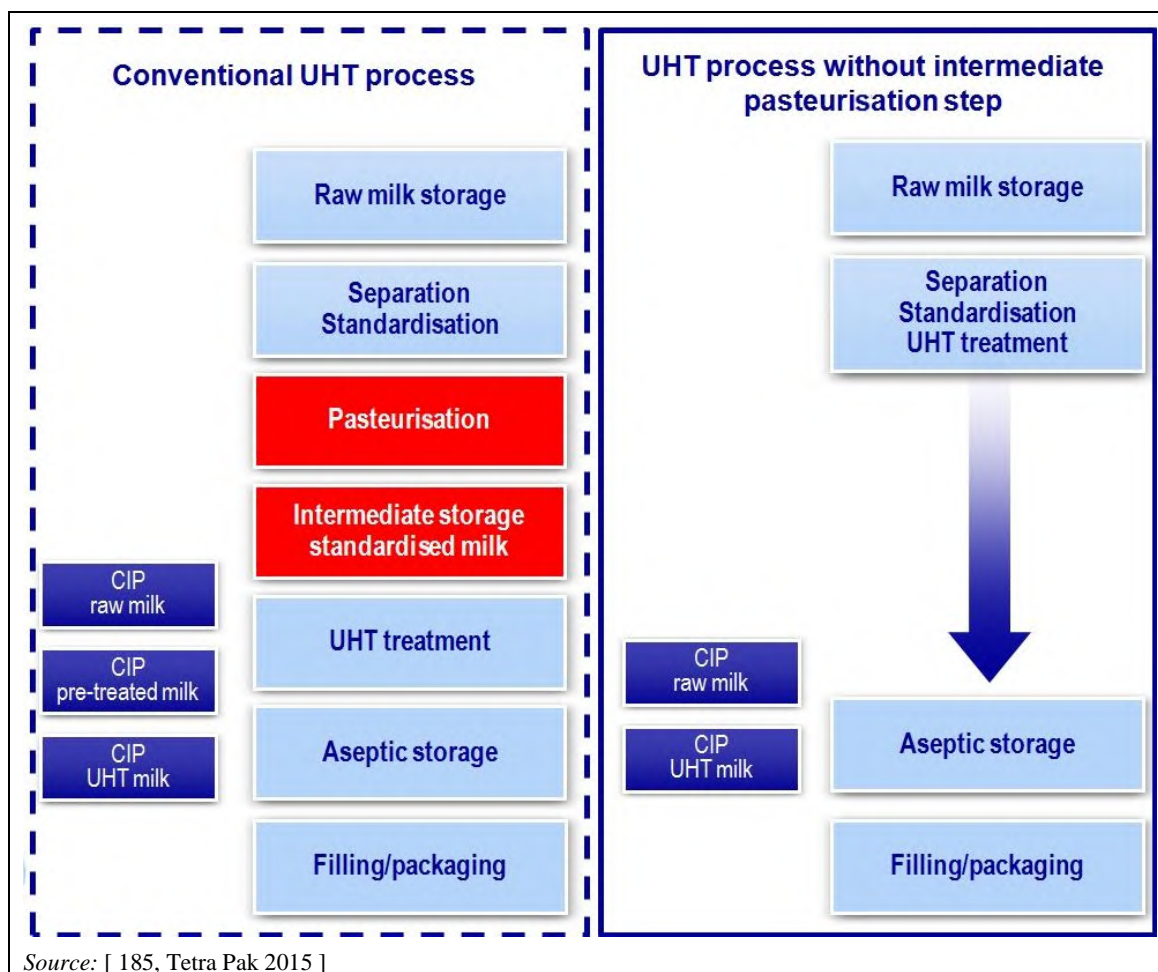

Figure 5.25: Comparison of UHT processes with and without the intermediate pasteurisation step

Achieved environmental benefits

Reduction of steam, electricity, water and cleaning agents consumption and product losses (waste generation).

Environmental performance and operational data

Compared with a traditional UHT process line, the reduction in electricity consumption can be up to 38 %, steam consumption up to 45 %, fresh water consumption up to 60 %, and product losses up to 33 %.

Cross-media effects

No information provided.

Technical considerations relevant to applicability

Generally, there are no technical restrictions to the applicability of this technique in dairies (within the constraints imposed by product availability and production mix). It is also applicable for flavoured milk processes.

Economics

This technique results in a 30 % reduction in the investment cost and a 50 % reduction in the operating cost compared to a traditional line.

Driving force for implementation

- Increase in production yield.
- Reduced total cost.
- Reduced floor space.

Example plants

This technique is implemented in 7–8 installations worldwide.

References

[185, Tetra Pak 2015]

5.4.2.8 Multistage drying in powder production**Description**

A spray-drying process is used in combination with a downstream dryer, e.g. fluidised bed dryer.

Technical description

After the milk has been thickened from 11 % to 50–60 % dry matter in an evaporator, the condensed milk may further be dried to 95–97 % dry matter content. Spray dryers or roller dryers are used in milk powder processing. Although roller dryers may be found in the dairy sector and are sometimes useful for specialised products, spray dryers with downstream or integrated fluidised bed dryers (FBDs) have become more common (see Figure 5.8). This is due to their lower energy usage, the primarily dust-free product, and to their reduced thermal stress which has an influence on the specification of the product.

A spray-drying process using a downstream FBD is also called a multistage dryer. Most modern configurations are with three stages of drying. The multistep concept should be considered when building new installations and taking into account the economics. Product specifications should also be taken into account.

Figure 5.26 shows a two-stage drying process carried out by using a spray dryer with a rotary atomiser and a separate external FBD. The outlet air is filtered by a CIP filter, which consists of a tubular filter without a cyclone.

When using multistage drying, lower residual product moisture with less harm to product quality as well as more efficient energy utilisation can be achieved. The solids leave the spray dryer with 3–5 % residual moisture. The final drying step in the fluidised bed takes place under mild conditions with low energy usage.

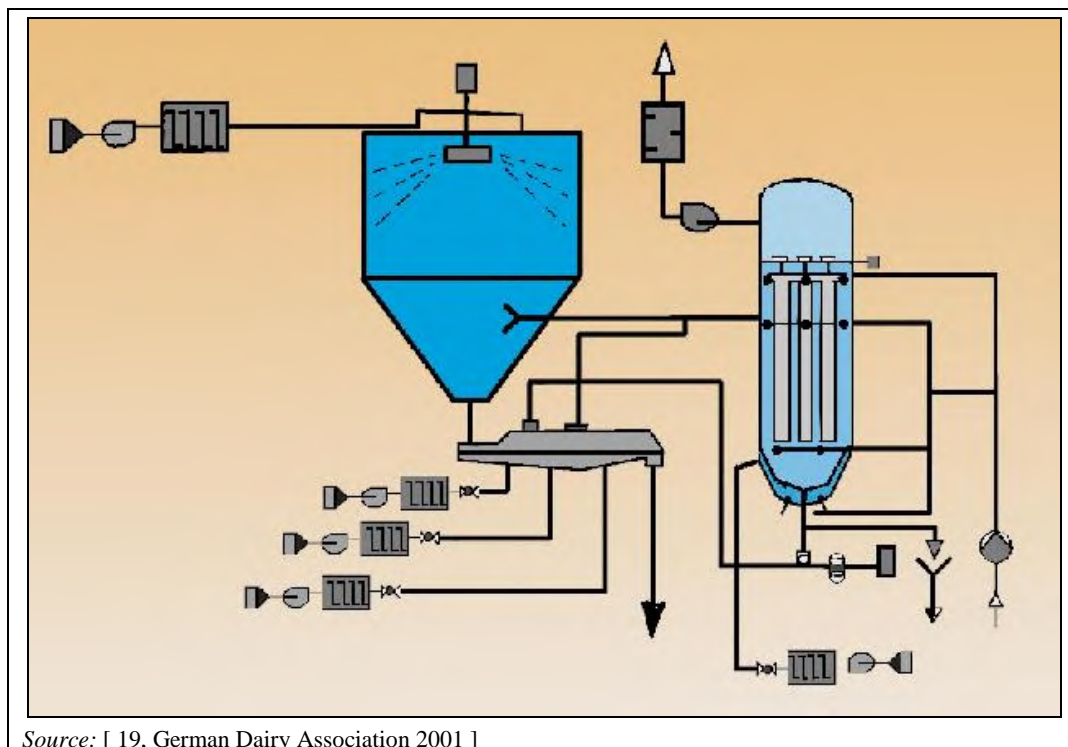

Figure 5.26: A two-stage drying process in a large dairy

Achieved environmental benefits

Reduced energy and water consumption. Reduced dust emissions.

Cross-media effects

Spray dryers produce noise emissions and explosive dust/air mixtures can occur.

Environmental performance and operational data

A large dairy in Germany produces skimmed milk and sweet whey powder. It processes 240 000 t of raw milk and produces 19 000 t of milk and whey powder. The dairy uses a two-stage drying system with a capacity of 1 t/h. The waste gas volume is 45 000 m³/h. The drying process uses the largest share, i.e. 58 %, of the thermal energy consumption of the installation, i.e. 39 million kWh of the total consumption of 67.5 million kWh. About 30 % of the total power consumption, i.e. 18 million kWh, was reportedly attributed to the drying process. In this example dairy, the reported specific electricity consumption was 315.8 kWh/t of product or 25 kWh/t of raw milk. The specific thermal energy consumption was 2 052.6 kWh/t of product or 162.5 kWh/t of raw milk. Taking into account that about 600 kWh energy is required to evaporate 1 tonne of water, these figures are near to the theoretical energy need. The total water consumption of the drying step was also low, i.e. 9 500 m³ or 0.5 m³/t of product or 0.04 m³/t of raw milk.

It is reported that if an integrated FBD is used, the energy consumption for drying can be reduced by approximately 20 %. Fire and explosion protection is required. An example of an early-warning fire alarm is CO detection.

Technical considerations relevant to applicability

Applicable in the dairy sector.

Economics

Investment involves additional capital and operational costs.

Driving force for implementation

Reduced energy and water costs.

Example plants

A large dairy making powdered milk in Germany.

Reference literature

[19, German Dairy Association 2001]

5.4.2.9 Precooling of ice-water**Description**

When ice-water is used, the returning ice-water is precooled (e.g. with a plate heat exchanger), prior to final cooling in an accumulating ice-water tank with a coil evaporator.

Technical description

Ice-water is used as a cooling medium, e.g. for cooling milk and vegetables. The amount of energy consumed for the production of ice-water can be reduced by installing a plate heat exchanger to precool the returning ice-water with ammonia, prior to final cooling in an accumulating ice-water tank with a coil evaporator. This is based on the fact that the evaporation temperature of ammonia is higher in a plate cooler than when evaporator coils are used, i.e. $-1.5\text{ }^{\circ}\text{C}$ instead of $-11.5\text{ }^{\circ}\text{C}$.

Achieved environmental benefits

Reduced energy consumption.

Environmental performance and operational data

In an example dairy, the precooling system saved almost 20 % electricity when installed in an existing ice-water system [21, Nordic Council of Ministers 2001].

In an example dairy (#124), heat pumps are used for heat recovery from the cooling system. This equipment moves the energy content in the lukewarm ice-water to the 'cold' hot water in the production process. The equipment thus makes it possible to produce part of the ice-water used in the production process (and with no excess heat outlet / emissions to environment) and to heat water without using heat from a boiler (and without emissions to air). In the system, $10\text{ }^{\circ}\text{C}$ ice-water (lukewarm water) from the production is cooled to $1.5\text{ }^{\circ}\text{C}$ in a plate heat exchanger by use of ammonia. The heat is transferred as a gas through a low-pressure compressor to a high-pressure compressor. In the high-pressure compressor the gas is compressed. The compressed gas is let through a plate heat exchanger where it condenses as it meets warm water ($65\text{ }^{\circ}\text{C}$) from the production. The condensed gas heats the $65\text{ }^{\circ}\text{C}$ water to $90\text{ }^{\circ}\text{C}$. The $90\text{ }^{\circ}\text{C}$ water is used in the production process to pasteurise milk. The ammonia is recirculated in the system.

Cross-media effects

Using ammonia involves safety risks. Leakages can be prevented by proper design, operation and maintenance.

Technical considerations relevant to applicability

This cooling system is commonly applied in new installations, but it can also be applied in existing installations.

Economics

The price depends on the existing ice-water system and capacity [21, Nordic Council of Ministers 2001]. In an example dairy, the investment costs were estimated to be approximately EUR 50 000, including a plate cooler, a pump, valves, regulators, pipework and installation. In another dairy, with a permitted milk production capacity > 600 tonnes/day, an installation cost of EUR 135 000 was reported [193, TWG 2015].

Driving force for implementation

Reduced consumption of electrical energy and/or increased cooling capacity, without the need for an investment in a new ice-water tank.

Example plants

A dairy in Sweden and dairies in Denmark (#124 and #133) [193, TWG 2015].

Reference literature

[21, Nordic Council of Ministers 2001], [193, TWG 2015]

5.4.2.10 Production of cheese

5.4.2.10.1 High-temperature cheese ripening with later humidification and ionisation of the ventilation air

Description

The temperature of the air is increased to shorten ripening times. The ventilation air is humidified and cleaned by a discharge tube which ionises the air which is passed through ventilation ducts.

Technical description

In cheese manufacturing, the temperature of the air is increased to shorten ripening times. This leads to a reduction in the demand for storage facilities, cooling power and ventilation energy. As a higher temperature increases the risk of dehydrating the cheese and of contamination by mould, the ventilation air is humidified and cleaned by a discharge tube which ionises the air which is passed through ventilation ducts. As ions in the ventilation air react with dust particles, microorganisms and viruses, the air is effectively cleared of these sources of contamination.

Achieved environmental benefits

Reduced energy consumption.

Environmental performance and operational data

In an example cheese installation, a project was started in January 1994 to reduce energy consumption. Before the project, the manufacturer stored cheese at 12 °C to allow ripening to take place. The temperature was increased to 15 °C. The ventilation air was humidified and cleaned of dust and microorganisms by ionisation prior to entering the warehouse. The new equipment allows the air temperature to rise to 16 °C at 85 % relative humidity. Energy savings amounting to 272 000 kWh/year, or 85 000 m³/year of natural gas, were reported. A shortening of the ripening time by 50 %, an improvement of the product quality and a reduction of the consumption of plastics and fungicidal agents were also reported.

Cross-media effects

No information provided.

Technical considerations relevant to applicability

Applicable in cheese manufacturing installations. High-temperature ripening is limited due to the desired taste, product quality and stability.

Economics

In the example installation, considerable savings were achieved in labour costs and maintenance and in the use of materials for cleaning the ventilation system. The payback period is around two years.

Driving force for implementation

Reduction in energy costs.

Example plants

A cheese warehouse in the Netherlands.

Reference literature

[77, CADDET 1997], [128, CIAA-Federalimentare 2003], [144, CIAA-EDA 2003]

5.4.2.10.2 Use of ultrafiltration for protein standardisation of cheese milk**Description**

The milk flows under pressure over a membrane that withholds the protein molecules, thus increasing the cheese yield per processed milk unit.

Technical description

Ultrafiltration (UF) can be used for protein standardisation of cheese milk. The milk flows under pressure over a membrane that withholds the protein molecules, thus increasing the protein content of the retentate. The membrane pore size ranges from about 10 nm to 100 nm.

As using UF leads to an increase in the cheese yield per processed milk unit, the generated quantity of whey is smaller compared to traditional standardisation. Furthermore, even when UF requires additional electrical power, thermal energy and water compared to traditional standardisation, in large-scale production the increase in cheese yield compensates for the increased consumption of energy and water. The permeate from the UF unit is further treated by RO. The RO water, which is of drinking water quality, can be used for cleaning purposes.

Achieved environmental benefits

Reduced energy and water consumption, whey and waste water in comparison with traditional standardisation.

Environmental performance and operational data

The UF unit in a Danish dairy consists of 10 spiral wound modules equipped with polymer membranes, four pumps and the necessary flow transmitters and regulating valves. The filtration capacity is 65 000 l/h. The protein content of the milk is standardised to 3.7–3.8 % by controlling the ratio between feed and permeate. Compared to the traditional standardisation method, the cheese yield is higher, i.e. about a 12 % reduction in milk volume was gained. A calculation made for a 25 000 t/year yellow cheese production installation led to the estimated savings in water and energy shown in Table 5.7.

Table 5.7: Savings in water and energy consumption in a dairy using UF for protein standardisation

Electrical energy	473 MWh/yr	19 kWh/t cheese
Thermal energy	1 235 MWh/yr	49 kWh/t cheese
Water	7 500 m ³ /yr	300 l/t cheese
<i>Source: [21, Nordic Council of Ministers 2001]</i>		

UF membranes have a limited lifetime of 1–3 years due to application. After use they are incinerated or sent for landfill.

Cross-media effects

The membranes need to be cleaned. As chemicals are used for this, the filter has to be well rinsed with large amounts of water. Used membranes require disposal.

Technical considerations relevant to applicability

UF can be applied to both skimmed milk and whey. UF units can be installed in new and existing installations because of their low space requirements.

Economics

The investment cost in the example Danish dairy is EUR 430 000 and the payback period is 5.9 years.

Driving force for implementation

Cheese of homogeneous quality can be produced using this technique. It also offers greater flexibility for making different types of cheese.

Example plants

A dairy in Denmark.

Reference literature

[21, Nordic Council of Ministers 2001]

5.4.3 Techniques to reduce water consumption

5.4.3.1 Dry cleaning

This technique is described in Section 2.3.3.2.1.

Technical description

Reported examples of applications of the technique are given below:

- adopt dry cleaning methods to collect the solid residues from cheese production;
- sweep curd losses instead of washing them to the drain;
- treat spills of curd, yoghurt or ice cream mix as waste rather than just washing them to the drain;
- use dry processes to collect excess salt rather than just washing it to the drain;
- fit drains with screens and/or traps to prevent any solid material from entering the waste water.

Reference literature

[8, Environment Agency of England and Wales 2000], [19, German Dairy Association 2001], [21, Nordic Council of Ministers 2001], [42, Greek Ministry for the Environment 1997], [71, AWARENET 2002]

5.4.3.2 Reduction of centrifuge cleaning requirements by improved preliminary milk filtration and clarification

Description

Reduction of centrifuge cleaning requirements by improved preliminary milk filtration and clarification.

Technical description

By improving the preliminary milk filtration and clarification processes, the deposits in the centrifugal separators are minimised, leading to a reduction in the frequency of cleaning.

Achieved environmental benefits

Reduced water consumption and waste water pollution.

Environmental performance and operational data

No information provided.

Cross-media effects

No information provided.

Technical considerations relevant to applicability

Applicable in dairies.

Economics

No information provided.

Driving force for implementation

Savings in water consumption.

Example plants

No information provided.

Reference literature

[71, AWARENET 2002]

5.4.3.3 Reuse and recycling of water

See also Section 2.3.3.1.1.

Description

Reuse and recycling of water for cleaning in dairies.

Technical description

Cooling water, condensates generated in evaporation and drying operations, permeates generated in membrane separation processes and cleaning water can be reused in dairy installations (e.g. condensate from the evaporator could be reused for the rinse step in the CIP). In the design, it is important to keep in mind, on one hand, their quality characteristics and temperature of each water stream and, on the other hand, the quality and temperature requirements of each process. This reuse is dependent on the microbiological and chemical quality of this water and the hygienic and microbiological requirements of installations. One way of minimising any hygiene risks is to treat the water with UV radiation.

In two Spanish installations (#189 and #191), the main streams to be reused are:

- the production condensates which are generated during thermal treatment and freezing and refrigeration;
- heated water from refrigeration: the right hygienic quality will be ensured if the product surface is cleaned with this water;
- rejected water from reverse osmosis: its reuse is possible for washing down the surface.

In two Danish installations (#125 and #134), RO water (the permeate from reverse osmosis (RO) filtration of whey) is reused. In installation #125, the CIP units account for 50 % of the total dairy water consumption. As a result of additional investments in a new piping system, valves and operation system, the consumption of fresh water in CIP was replaced to a large extent by RO water. In installation #134, a RO water recirculation system with holding tanks and with a UV light to secure the microbial safety of the permeate has been installed.

Avoiding unnecessary contamination of condensate maximises the potential for water recycling or reuse, sometimes without any treatment, depending on the intended use. The cleanest condensate may be suitable for use as boiler feed water.

Table 5.8 shows some water recycling opportunities in dairies.

Table 5.8: Water recycling opportunities at dairies

Reuse \ Use	CIP used cleaning solution	CIP final rinse	Condensate	Permeate from RO installation
Cleaning the outsides of vehicles	1	1	1	1
Crate cleaning	2	1	1	1
Manual cleaning of the outside of equipment	3	3	1	1
CIP pre-rinse	2	1	1	1
CIP main cleaning supply	3	3	3	1
CIP final rinse	NO	3	3	3
Water purge of product lines	NO	3	3	3

NB: 1 = Direct reuse; 2 = Reuse after screening of solids; 3 = Reuse after advanced treatment, e.g. membrane separation and/or disinfection; NO = no reuse.
Source: [192, COM 2006]

For more information about water recycling in dairies after using membrane separation techniques, see Section 5.4.3.4.

Water from cheese production can also be reused. In a Danish installation (#129), this water is pasteurised to ensure that it is of drinking water quality and it is used for CIP cleaning in the production area.

Many dairy operations involve cooling with cold water in heat exchangers, which results in warm cooling water. Usually, the warm cooling water from the process is reused for cleaning purposes, mainly for cleaning milk tankers. Warm cooling water can generally be used for cleaning the installation, regardless of its temperature. In the dairy industry, water above 50 °C can be reused for the cleaning of milk tankers or for the manual cleaning or CIP of equipment.

Achieved environmental benefits

Reduced water and energy consumption and waste water generation, and reduced contamination of waste water.

Environmental performance and operational data

In an example Nordic dairy reusing warm cooling water for cleaning, a reduction in water consumption of about 2 % has been reported [21, Nordic Council of Ministers 2001].

In a Swedish installation (#393), cooling water is collected and stored as lukewarm water in a 100 m³ tank. This water is reused for the CIP process. The water is stored at approximately 70 °C. This will save the energy that is required to heat up the water from 8 °C to 70 °C.

Cross-media effects

Electricity consumption for pumps.

Technical considerations relevant to applicability

Reuse of cooling water can be applied in new and existing installations. The space requirements for the warm water storage tanks may be a constraint in existing installations. Its use also depends upon what chemicals, if any, were previously used in the cleaning. Double piping for reused water and drinking water may be needed.

Economics

The technique is reported to have a high investment cost but low operating cost (#189 and #191) [193, TWG 2015].

A payback period of < 1 year (#125) for using RO water in CIP operations with a 10 % potential water saving was reported. And a payback period of 1–2 years (#134) for replacing fresh water with RO water with a 16 % potential water saving was reported [47, Denmark 2017].

Driving force for implementation

- Significant savings in terms of waste water treatment cost.
- Reduced need to purchase drinking water.

Example plants

Two dairies, one in Sweden and the other in Finland, reuse warm cooling water for cleaning [21, Nordic Council of Ministers 2001]. At least one milk-producing dairy in the UK uses treated evaporator condensate for cleaning.

Installations #124, #129, #134, #189, #191 and #393 [193, TWG 2015].

Reference literature

[21, Nordic Council of Ministers 2001], [47, Denmark 2017], [57, Environment Agency of England and Wales 2002], [192, COM 2006], [193, TWG 2015]

5.4.3.4 Water recycling by using membrane filtration techniques

See also Section 2.3.3.1.1.

Description

Recycling of water in dairies by using membrane filtration techniques.

Technical description

Used water, from various dairy production steps, is purified using membrane filtration techniques and recycled in several process parts. This high-quality water can then be recycled as boiler feed water, process, cooling and/or rinsing water or be discharged directly into a drainage ditch. Examples of water recycling in dairies include:

- condensate from evaporation plants can be filtered in a condensate polisher to convert a waste stream into a water stream, using reverse osmosis (RO);
- waste water is sent to an ultrafiltration (UF) and RO plant and reused in the process;
- waste water from activated sludge treatment is reused for the CIP, after passing through UF and RO membranes.

Achieved environmental benefits

Reduction of water use and waste water generation. Valuable by-products can be produced and waste generation reduced.

Environmental performance and operational data

In installation #406, water vapour produced during evaporation of whey is condensed and recycled within creamery operations following treatment in the reverse osmosis membrane plant. Process condensate from the evaporator is monitored by conductivity probes to check for any product entrainment prior to being fed forward to the membrane plant to protect the membranes. Recovered water (permeate from the membrane plant) is routed to the process water tank along with other sources of incoming water used for applications such as CIP make-up and rinse water, boiler make-up, cooling tower make-up, etc. This recovery of process condensate for recycling reduces:

- fresh water abstraction by over 300 000 m³/year, contributing more than 50 % of the site demand;
- energy consumption associated with treatment of waste water;
- chemical use associated with treatment of waste water.

Moreover, in installation #406, significant investment has been made in process water treatment. This includes additional capacity for process effluent balancing, anoxic treatment, aeration and settlement. This supplements existing physico-chemical (dissolved air flotation) and biological (aerobic) treatment processes. The investment in the process water treatment plant also extends to multiple stages of tertiary treatment to produce high-quality water (biologically inert and conductivity < 200 $\mu\text{S}/\text{cm}$) suitable for reuse in dairy process operations (see Figure 5.27). The water treatment system to enable reuse is designed to recover 1 700 m^3/day of water for return to the process in the creamery. Several stages of treatment are required including membrane separation processes (UF followed by RO) with the resultant permeate receiving subsequent ultraviolet treatment and chlorination. The permeate is then returned to the creamery for use in production processes.

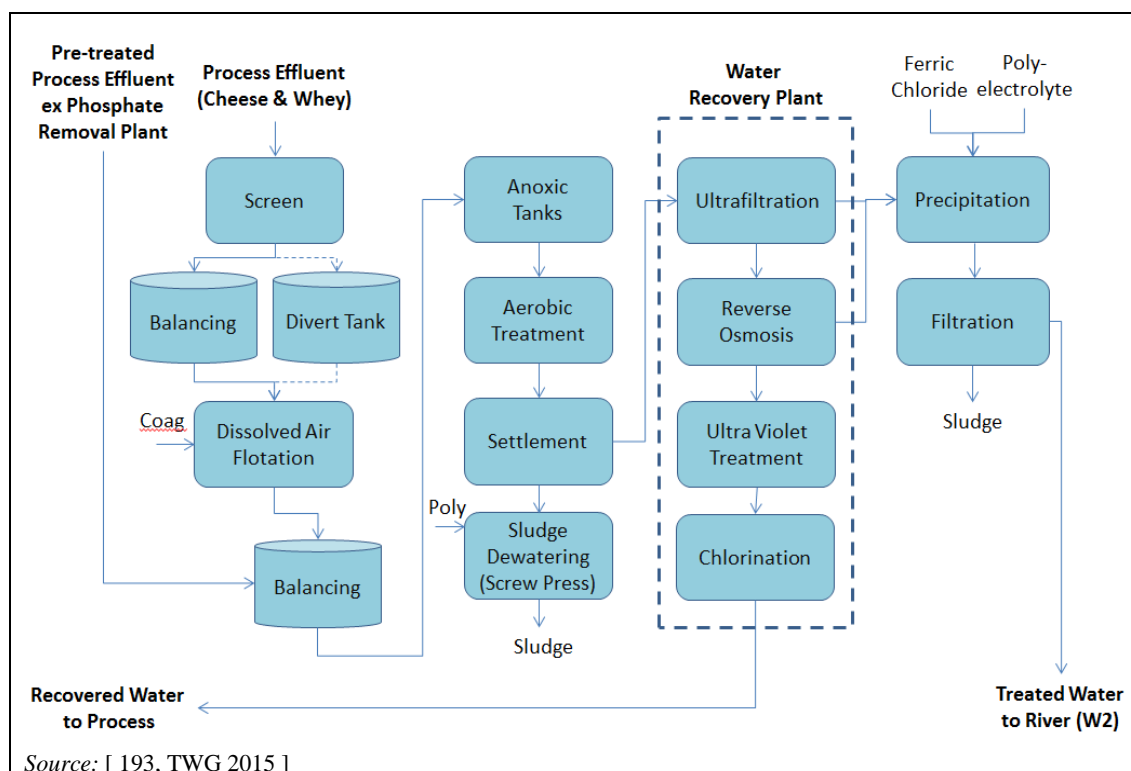

Figure 5.27: Water recycling scheme in a dairy

In installation #408, separated whey is sent through an UF plant where the proteins are removed. The condensate from the UF is then sent through a RO membrane plant which separates the water and lactose. The lactose is sent for further processing and then the water (milk water) is further filtered through a membrane polisher. This polished water can then be used in CIP or as boiler make-up water.

In installation #295, product condensates are put through RO to produce water for several secondary applications such as CIP.

Cross-media effects

Consumption of energy is required to treat the waste water. Chemicals are used due to requirements regarding protection of the membrane material.

Technical considerations relevant to applicability

Applicable in all dairies.

Economics

Operating costs are usually high in membrane plants but depend on the scale of the installation. The investment in enhanced waste water treatment and recovery enables the production of

recovered water from process waste water suitable for reuse in creamery operations at less than 50 % of the purchase price of municipal potable water [193, TWG 2015].

Driving force for implementation

Reduction in costs related to water and energy supply.

Example plants

Installations #295, #406 and #408.

Reference literature

[26, Envirowise (UK) 2000], [193, TWG 2015]

5.4.4 Techniques to reduce waste

5.4.4.1 Separation of residues

Description

This technique is described in Section 2.3.5.3.

There are many other opportunities to apply this technique within the sector:

- collect leaked and spilt ingredients and partly and fully processed materials;
- collect whey which is not intended for making mitzithra cheese, baby food or other products;
- collect milky waste water generated at the start-up of pasteurisers;
- recover the milk with presses from cartons refused due to defects;
- prevent the solid waste obtained after centrifugation from entering the waste water;
- collect and recover product/product mixtures from product changeovers;
- separate and collect buttermilk, first rinses and residual fat in butter-churning operations, to use it in other processes, e.g. as a base for low-fat spreads;
- collect rinsings from yoghurt vats;
- collect the drainings of yoghurt and fruit throughout the dairy;
- collect and empty the products from wrongly filled containers for use as animal feed, e.g. by maceration of packaging;
- measure the fats/solids in the line (using a turbidity meter) and redirect them to a balance tank (they can then be redosed into the pasteuriser to increase the product yield);
- general separation of the liquid from the packaging.

Achieved environmental benefits

Reduced waste and reduced waste water treatment.

Environmental performance and operational data

In a Swedish installation (#387), a rotating compressor screw crushes the packages and drain off liquid products. A compressor screw squashes 99.5 % of the liquid out. The liquid products are reused as animal foodstuff or can be anaerobically digested to produce biogas. The packaging is then shredded and used as fuel at cogeneration facilities or can be sent for recycling into new cardboard. The system capacity is 8 000 Packages/hour (board) and 5 000 Packages/hour (plastic) [193, TWG 2015].

Cross-media effects

No information provided.

Technical considerations relevant to applicability

Applicable to all dairies.

Economics

An investment cost of around EUR 250 000 has been reported for the installation of a system for separation of liquid from the packaging (capacity: 8 000 packages/hour for cardboard, 5 000 packages/hour for plastic) [193, TWG 2015].

Driving force for implementation

Reduced costs associated to waste water treatment and waste disposal.

Example plants

Various installations in the EU [193, TWG 2015].

Reference literature

[8, Environment Agency of England and Wales 2000], [19, German Dairy Association 2001], [21, Nordic Council of Ministers 2001], [42, Greek Ministry for the Environment 1997], [71, AWARENET 2002], [193, TWG 2015]

5.4.4.2 Just-in-time mixing component filling

Description

Milk products are diversified as late as possible, preferably immediately prior to filling.

Technical description

A filling machine concept called component filling enables milk products to be diversified as late as possible, preferably immediately prior to filling. In this machine there are two pipelines, one with skimmed milk and the other with milk of a standardised fat content. These are mixed at the filling machine to the ratio required for each particular product. For example, a dairy might produce three types of milk, with three different fat contents and these would be achieved by changing the amount supplied from the two pipelines. Losses of product and packaging materials caused by changeovers in production can be eliminated using this technique. Component filling also reduces the need for in-line storage tanks and the corresponding cleaning requirements.

Achieved environmental benefits

Reduced product and packaging waste. Reduced water consumption, e.g. for cleaning and reduced waste water pollution.

Environmental performance and operational data

Normally, 75–100 litres of milk can easily be lost because of the changeover of production in a traditional filling operation.

Cross-media effects

No information provided.

Technical considerations relevant to applicability

Modification of the pipework and an automation system is needed before installing the machine in an existing installation.

Economics

The price of a new component filling machine with a filling capacity of 12 000–12 500 packs/h is approximately EUR 1 million (2001), not including any process modification that may be needed. In many cases, one component filling machine may replace several ordinary fillers.

Driving force for implementation

Flexibility of the production is increased, allowing a more consumer-driven approach.

Example plants

There are a total of three component filling machines in the Nordic countries, including one in Finland.

Reference literature

[21, Nordic Council of Ministers 2001], [109, Finland 2003]

5.4.4.3 Optimised operation of centrifuges**Description**

Operation of centrifuges according to their specifications to minimise the rejection of product.

Technical description

Both the frequency and the volume of waste discharges from centrifuges are usually specified by the manufacturers of the equipment. Where this information is known, the actual performance can be checked against the specification. By running the equipment at its specified performance, it may be possible to reduce the amount of the phase discharged as waste and increase that retained as product, whilst maintaining quality and hygiene standards. This may be achieved by maintaining close cooperation with quality assurance personnel.

Achieved environmental benefits

Reduced wastage of raw materials.

Environmental performance and operational data

It is reported that in dairies 1 % of raw milk supplied is wasted and that 0.1 % of this is during the processing of the milk and most of that is lost via discharges during centrifugal separation.

Cross-media effects

No information provided.

Technical considerations relevant to applicability

Applicable for all centrifugal separators.

Economics

No information provided.

Driving force for implementation

Reduced loss of raw materials and increased yield.

Example plants

No information provided.

Reference literature

[7, Environment Agency of England and Wales 2000]

5.4.4.4 Butter production**5.4.4.4.1 Rinsing of the cream heater with skimmed milk or water****Description**

Rinsing of the cream heater with skimmed milk or water, which is then recovered and reused, before the cleaning operations.

Technical description

Due to the high viscosity of cream, the cream heater may be rinsed with skimmed milk or water, which is then retained and reused, before the cleaning. This reduces fat losses. Buttermilk which

results as a by-product can be used as a product and not disposed of, e.g. into the waste water. These savings may be used, for example, as a base for low-fat spreads.

Achieved environmental benefits

Reduced food waste.

Environmental performance and operational data

No information provided.

Cross-media effects

No information provided.

Technical considerations relevant to applicability

Applicable in butter- and cream-making.

Economics

No information provided.

Driving force for implementation

Reduced waste and increased product yield.

Example plants

No information provided.

Reference literature

[[226, EDA 2016](#)]

5.4.4.5 Production of ice cream

5.4.4.5.1 Continuous freezing of ice cream mix

Description

Continuous freezing of ice cream mix using optimised start-up procedures and control loops that reduce the frequency of stoppages.

Technical description

Continuous freezing of ice cream mix using optimised start-up procedures and control loops that reduce the amount of start-up rework and waste. The improved control also gives a much more even output, closer to the desired target. This is achieved by decreasing the standard deviation. This leads to less waste or alternatively the ice cream producer can make more sellable products from the additional amount of ice cream mix within the same available time and without use of extra raw material.

Achieved environmental benefits

This technique leads to a more efficient utilisation of raw material (ice cream mix), which avoids any environmental impact in the whole supply chain. It also reduces waste and consequently the TOC or COD load in the waste water. Finally, it reduces electricity consumption.

Environmental performance and operational data

Considering, for example, an ice cream bulk filling line with a capacity of 4 000 litres/hour: with two product changes per day, the COD effluent load in the start-up waste could be reduced from 20 kg to 13 kg COD/tonne of ice cream mix (35 % reduction). With more stops/product changes, the start-up waste and COD load reduction will be even higher.

In another example, an installation with a production capacity of 2 000 litres ice cream/hour, a production time of 3 000 hours/year, two basic start-ups per day, two product changes per day, the benefits of applying this technique are reported as:

- less start-up waste: 12 500 kg/year (23 000 litres);
- less product waste: 25 000 kg/year (44 000 litres);
- reduced electricity consumption: 12 000 kWh/year.

Cross-media effects

No information provided.

Technical considerations relevant to applicability

This technique can be applied in ice cream installations with continuous freezing of ice cream mix. It can be used both in new installations and for upgrading existing ice cream freezers.

Economics

The payback time is normally less than one year.

Driving force for implementation

- Reduced operational costs.
- Shorter start-up times.
- More sellable products per kg of ice cream mix and thus higher profit.

Example plants

This technique is in operation in many ice cream installations of the EU-28 and savings have been validated.

Reference literature

[181, Tetra Pak 2015]

5.4.4.6 Cheese production

5.4.4.6.1 Minimisation of the generation of acid whey

Description

Whey from the manufacture of acid-type cheeses (e.g. cottage cheese, quark and mozzarella) is processed as quickly as possible to reduce the formation of lactic acid.

Technical description

For acid-type cheeses, lactic acid mother cultures are grown on media and then bulk cultures are propagated and added to milk to make cheese. Acid whey is separated after curd formation. If acid whey is discharged to a WWTP, it may cause low pH levels. To prevent this, spillages are avoided by draining the top or platform of the salting vats. In addition, whey can be processed quickly so less acid whey is produced due to lactic acid formation.

Achieved environmental benefits

Reduced waste water pollution.

Environmental performance and operational data

No information provided.

Cross-media effects

No information provided.

Technical considerations relevant to applicability

Applied in the manufacture of acid-type cheeses, e.g. cottage cheese, quark and mozzarella.

Economics

Reduced waste water treatments costs.

Driving force for implementation

Reduced waste water treatments costs.

Example plants

No information provided.

Reference literature

[8, Environment Agency of England and Wales 2000]

5.4.4.6.2 Reduction of fat and cheese fines in whey

Description

The highest possible yield of fat and protein is achieved and afterwards the whey is screened to collect the remaining fines.

Technical description

To accomplish the reduction of fat and cheese fines in whey, first, during the processing of the curd, the highest possible yield of fat and protein is achieved and afterwards the whey is screened to collect the remaining fines.

Achieved environmental benefits

One benefit is reduced product loss. If whey is allowed to enter the WWTP, the pollutant load is lower; see Section 5.4.4.6.1 for minimising the generation of acid whey.

Environmental performance and operational data

No information provided.

Cross-media effects

There may be odour emissions, depending for example on the type and size of the fines screened.

Technical considerations relevant to applicability

Applicable in cheese manufacturing installations.

Economics

Optimisation of production costs. Reduced waste water treatments costs.

Driving force for implementation

Reduced product losses.

Example plants

No information provided.

Reference literature

[71, AWARENET 2002]

5.4.4.6.3 Recovery and use of whey

Description

Whey is recovered (if necessary using techniques such as evaporation or membrane filtration) and used, e.g. to produce whey powder, demineralised whey powder, whey protein concentrates or lactose. Whey and whey concentrates can also be used as animal feed or as a carbon source in a biogas plant.

Technical description

Sweet whey is produced during the making of rennet-type hard cheeses, e.g. Edam or Swiss cheese. Salt whey is produced in cheddar-type cheese manufacture after salt has been added to the curd and the curd is pressed to remove additional salt whey. Sweet whey is collected and reused in the process or in other processes to make by-products, e.g. for protein recovery, as animal feed, as a food supplement or in baby food. Even when salt whey cannot be reused in the process without the removal of the salt, it can either be collected as it is or concentrated by evaporation and used as animal feed.

The whey can be sent to an ultrafiltration plant where the proteins are removed. The condensate from the UF is then sent through a reverse osmosis membrane plant which separates the water and lactose. The lactose is sent for further processing and then the water (milk water) is further filtered through a membrane polisher. This polished water can then be used in CIP or as boiler make-up water.

Figure 5.28 shows a flow diagram of a membrane processing system in cheese manufacturing.

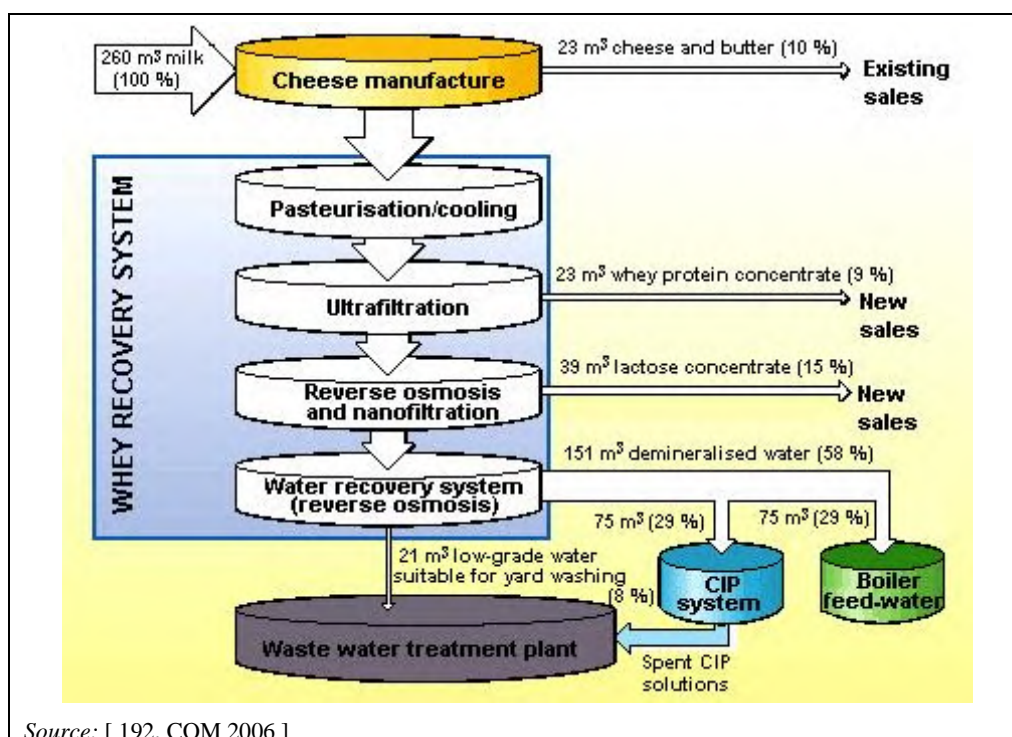

Figure 5.28: Flow diagram of the membrane processing system

Achieved environmental benefits

Reduced waste water pollution. Reduced waste, i.e. whey is reused.

Environmental performance and operational data

In a dairy installation, whey, a by-product of cheesemaking, is concentrated using an evaporation stage prior to spray drying to make whey powder. The evaporators are regularly

cleaned in place, which involves flushing out residual concentrated whey prior to detergent cleaning, i.e. pre-rinsing. A significant quantity of whey was being lost down the drain when the evaporator was taken off-line for CIP [192, COM 2006].

A turbidity probe was installed at the end of the fill line to the concentrate tank as part of an automatic recovery system. The probe detects the presence of water/whey mixtures and sends this information back to the control system. Recovery of concentrated whey to the whey storage tank is then controlled via a densiometer, while the turbidity probe controls the recovery of the water/whey mixture to a separate tank. The mixture is subsequently mixed with raw whey for reprocessing. When the turbidity is between certain set points indicating the presence of whey, the flow is automatically diverted to the recovery tank via actuated valves. When the detergent cycle starts, the probe signal is overruled to ensure no acid or alkaline detergent is diverted into the whey tank. Contamination of the recovered whey is avoided and only clear water or water containing detergent is discharged for waste water treatment. The whey recovery process is shown in Figure 5.29.

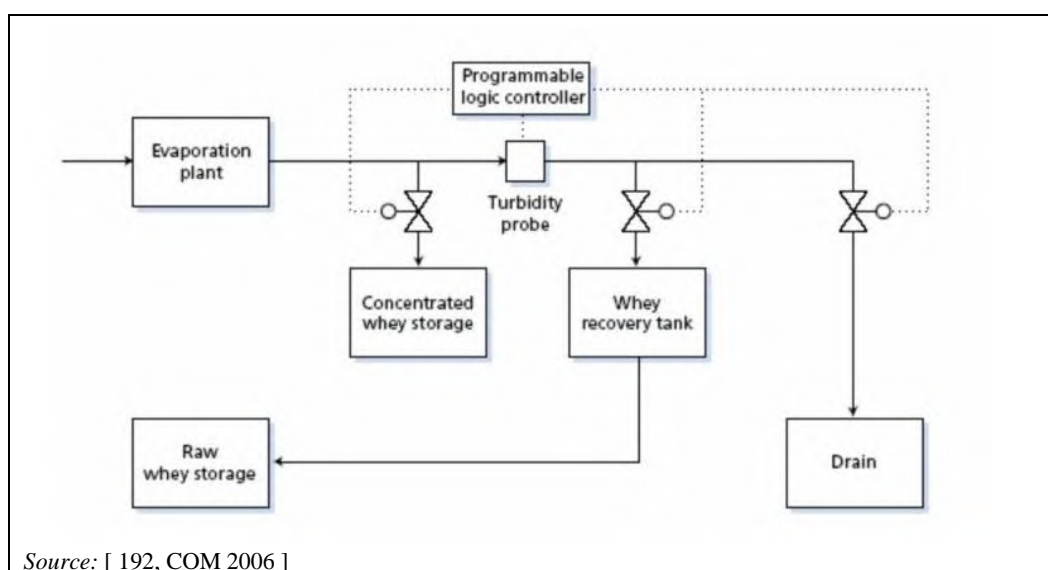

Source: [192, COM 2006]

Figure 5.29: Whey recovery using turbidity measurement

It is reported that no problems have occurred since the whey recovery system began operating in 1996. When the system was first installed, training was provided for operators to make them aware of how the new system operated and its benefits. Operating costs are reported to be negligible and the turbidity probe requires little maintenance. The probe is cleaned in place when the main evaporator is cleaned. Planned maintenance is performed annually. The benefits reported include cost savings, increased product yield, less whey lost down the drain and lower WWTP costs.

In installation #406, liquid whey is concentrated in a multistage evaporator. The initial concentration is carried out through Mechanical Vapour Recompression (MVR), raising the solids content from 6 % to 35 %, followed by further concentration through Thermal Vapour Recompression (TVR), raising the solids content to 60 % prior to crystallisation and subsequent spray drying. Typically 3 500 MWh per year (electricity) are used in MVR compressor motors.

In installation #005, savings of 22 000 kWh electrical power each month and 500 t steam yearly have been achieved with the application of RO for whey thickening, in comparison to the previously used method of vacuum evaporation.

In installation #127, whey from cream cheese manufacturing is sent to the biogas plant in a fixed pipe for the production of biogas.

Cross-media effects

No information provided.

Technical considerations relevant to applicability

Applicable in cheese manufacturing installations.

Economics

No information provided.

Driving force for implementation

Reduced waste water treatments costs.

Example plants

Installations #005, #127 and #406 [193, TWG 2015].

Reference literature

[21, Nordic Council of Ministers 2001], [71, AWARENET 2002], [192, COM 2006], [193, TWG 2015]

5.4.5 Techniques to reduce emissions to water**5.4.5.1 Salt management - Handling of brine in cheese production****Description**

Integrated salt management in cheese production for reduction of salt in waste water.

Technical description

Salt management techniques that can be implemented include the following:

- Extension of time for brine draining above tanks, i.e. no loss of brine to waste water.
- Installation of conductivity meters with alarms in transition wells of the WWTP. The alarm allows operators to check and take action in those cheese installations where the high salt content in waste water originates.
- Less salt discharge from the CIP of the brining system to the WWTP as the frequency of CIP can be changed, e.g. from one to two weeks.
- Employee involvement – responsibility and more control and focus on the reduction of the salt content in waste water.
- Disposal of surplus brine to the biogas plant (thus no longer led to the WWTP). Disposal of surplus brine is assessed due to the local conditions of the receiving water body. Surplus brine is discharged to the WWTP continuously and not in one batch, to ensure the effectiveness of the biological treatment.

Achieved environmental benefits

Reduction of chloride in waste water.

Environmental performance and operational data

Reductions of raw material (salt) usage that have been achieved in installation #126 are:

- 2012: 0.08 tonnes of salt per tonne of produced cheese;
- 2013: 0.05 tonnes of salt per tonne of produced cheese;
- 2014: 0.05 tonnes of salt per tonne of produced cheese.

Brine in this installation is not discharged to the WWTP but to a biogas plant.

Cross-media effects

Small increase in energy consumption due to the use of conductivity meters.

Technical considerations relevant to applicability

No information provided.

Economics

An investment cost of around EUR 32 000 (purchase of three conductivity meters, programming of a crane to extend the time for brine draining, installation of alarms, dissemination of information to employees about the salt content in waste water) and an operating cost of around EUR 11 000/year (including daily analysis of chlorides in waste water) have been reported.

Driving force for implementation

Reduction of costs associated with waste water treatment.

Example plants

At least one installation in the EU [193, TWG 2015].

Reference literature

[193, TWG 2015]

5.4.6 Techniques to reduce emissions to air

5.4.6.1 Techniques to reduce dust emissions from dryers

5.4.6.1.1 Bag filter

The technique is generally described in Section 2.3.7.2.2.

Environmental performance and operational data

In a UK dairy (#406), atmospheric emissions from the drying of whey powder are first treated in a cyclone and subsequently a bag filter (see Figure 5.30) to achieve a total dust emission concentration of typically $< 10 \text{ mg/Nm}^3$. The indicative volumetric flow is around $105\,000 \text{ Nm}^3/\text{h}$ and the abatement efficiency of the system reaches 99 %.

Demineralised whey powder fines from the cyclone are returned to product stream (dryer inlet along with whey concentrate). Whey powder fines from the bag filter have historically been recovered to the product stream. However, on commencement of production of demineralised whey powder, the inclusion of bag filter fines is not possible due to the potential for entrainment of bag filter media which is not acceptable for the demineralised whey product. Bag filter fines are recovered as low-grade whey for use in applications such as animal feed. Filter is routinely inspected during shutdown and turnaround periods. Filter media are typically replaced every 2 years via a rolling programme.

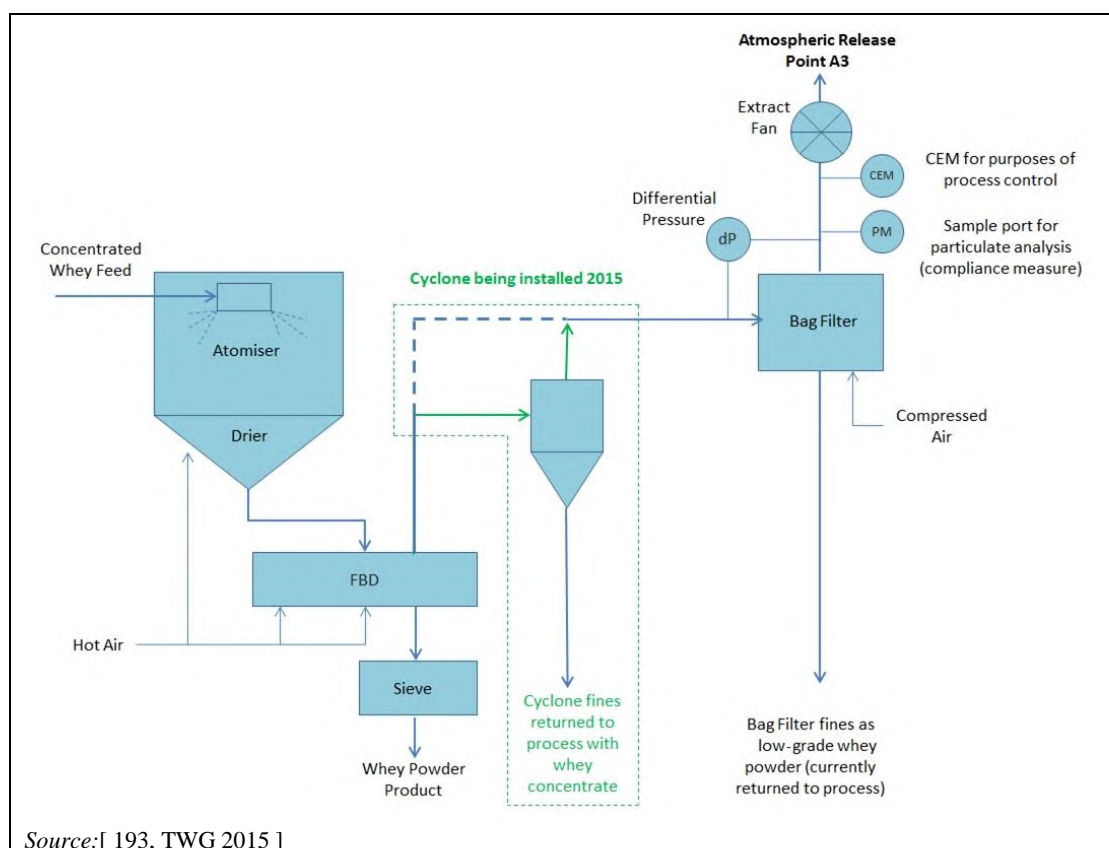

Figure 5.30: Example treatment for emissions to air from the drying of whey powder

Table 5.9 and Table 5.10 present installation-specific performance data related to the application of bag filters for treatment of emissions to air from a dryer.

Table 5.9: Dust emissions to air from a dryer after treatment in a bag filter (dry basis)

Installation ID-point of release	Dust (mg/Nm ³)	O ₂ content (%)	Monitoring standard	Frequency of monitoring	Additional information
131-4	0.13	4.36	NI	NI	Spray dryer (milk powder) Natural gas Cyclone step before
255-4	0.20	20.90	EN 13284-1	Yearly	Spray dryer (infant powder) Hot air from exchanger Cyclone step before
130-2	0.28	NI	VDI 2066	Yearly	Spray dryer (whey protein concentrate) Natural gas Cyclone step before
338-5	0.30	NI	EN 13284-1	Once every three years	Concentrated liquid products Cyclone step before
056-1	0.70	NI	EN 15259	Yearly	Spray dryer (skimmed milk powder) Hot air from exchanger Tubular filter
234-3	0.80	NI	EN 13284-1	Biennial	Spray dryer (demineralised whey powders) Steam
235-1	1.70	21.00	SFS 3866	Biennial	Spray dryer (skimmed milk, buttermilk) Steam

130-6	2.00	NI	VDI 2066	Yearly	Spray dryer (permeate/lactose powder) Steam Cyclone step before
338-4	2.50	NI	EN 13284-1	Once every three years	Concentrated liquid products Cyclone step before
057-1	2.60	NI	EN 13284-1	NI	Spray dryer (skimmed milk) Steam The dust is food-grade quality (rest of skimmed milk powder went through filter)
130-7	3.40	NI	VDI 2066	Yearly	Spray dryer (whey protein concentrate) Steam Cyclone step before
294-1	3.69	NI	EN 13284-1	Four times a year	Spray dryer (skim, milk protein concentrate) Steam
340-1	5.00	NI	NI	Biennial	Spray dryer (powder and lactose) Steam
295-2	6.68	NI	EN 13284-1	Four times a year	Spray dryer (whey protein powder) Steam
294-3	7.24	NI	NI	Four times a year	Spray dryer (buttermilk powder, whey protein concentrate, skimmed milk powder) Steam
296-9	7.60	NI	EN 13284-1	Four times a year	Spray dryer (powder) Coal
063-3	8.00	NI	NI	Yearly	Spray dryer Steam
294-6	9.40	NI	NI	Four times a year	Spray dryer (lactose) Steam
068-1	10.00	21.00	NI	Yearly	Spray dryer (whey powder) Steam
234-2	14.80	NI	EN 13284-1	Biennial	Spray dryer (demineralised whey powders, skimmed milk powders) Steam
296-9	22.74	NI	EN 13284-1	Four times a year	Flash/ring dryer (powder, lactose) Coal
NB: NI = no information provided. Source: [193, TWG 2015]					

Table 5.10: Average and maximum values of continuous measurements of dust in dryer emissions to air after treatment in a bag filter (dry basis)

Installation ID-point of release	Dust (mg/Nm ³)		O ₂ content (%)	Additional information
	Yearly average	Max.		
062-4	0.64	9.83	NI	Spray dryer (lactose) Hot air from exchanger Tubular filter
062-2	4.42	11.20		Spray dryer (whey protein concentrate) Hot air from exchanger Tubular filter
062-1	4.45	12.00		Spray dryer (whey) Hot air from exchanger Tubular filter
062-3	5.40	14.30		Spray dryer (whey protein concentrate) Hot air from exchanger Tubular filter
405-1	21.00	44.00	NI	Spray dryer (skimmed milk powder, buttermilk powder) Fuel oil
405-2	21.00	50.00		
NB: NI = no information provided. Source: [193, TWG 2015]				

Economics

Cleaning costs increase for dryers treating whole milk instead of skimmed milk, due to the difficulty of fat removal [98, TWG 2017].

Reference literature

[98, TWG 2017], [193, TWG 2015]

5.4.6.1.2 Cyclone

The technique is generally described in Section 2.3.7.2.3.

Environmental performance and operational data

Table 5.11 shows installation-specific performance data related to the application of cyclones as an end-of-pipe technique for treatment of emissions to air from a dryer. Cyclones are also used as a pretreatment step before the final application of a bag filter (see Table 5.9).

Table 5.11: Dust emissions to air from a dryer after treatment in a cyclone (dry basis)

Installation ID-point of release	Dust (mg/Nm ³)	O ₂ content (%)	Monitoring standard	Frequency of monitoring	Additional information
255-1	1.40	20.90	EN 13284-1	Yearly	Spray dryer (milk dryer) Natural gas Very small particles (milk powder and water steam)
259-2	7.34	NI	ISO/IES 17025, COFRAC 1-1488	NA	Spray dryer (infant formula) Steam
294-4	15.03	NI	EN 13284-1	Four times a year	Spray dryer (casein) Steam
255-3	8.80	20.90	EN 13284-1	Yearly	Spray dryer (mix dryer - whey, buttermilk, milk) Steam Very small particles (milk powder and water steam)
294-6	13.64	NI	EN 13284-1	Four times a year	Lactose dryer
234-1	19.60	NI	EN 13284-1	Biennial	Spray belt dryer (demineralised whey powders, special products) Steam
252-2	16.60	NI	EN 13284-1	Four times a year	Spray dryer (infantile and formulated powder) Hot air from exchanger
252-1	13.63	NI	EN 13284-1	Four times a year	Spray dryer (fat and thin powder) Natural gas
251-1	34.90	NI	Norme COFRAC	Yearly	(Infant powder) Hot air from exchanger
296-4	37.79	NI	EN 13284-1	Four times a year	Spray dryer (powder, lactose) Coal
296-5	46.50	NI	EN 13284-1	Four times a year	Spray dryer (powder, lactose) Coal

NB: NI = no information provided.
Source: [193, TWG 2015]

Reference literature

[193, TWG 2015]

5.4.6.1.3 Wet scrubber

The technique is generally described in 2.3.7.3.1.

Environmental performance and operational data

Table 5.12 shows installation-specific performance data related to the application of wet scrubbers as an end-of-pipe technique for treatment of emissions to air from a dryer.

Table 5.12: Dust emissions to air from a dryer after treatment in a wet scrubber (dry basis)

Installation ID-point of release	Dust (mg/Nm ³)	O ₂ content (%)	Monitoring standard	Frequency of monitoring	Additional information
130-1	0.10	NI	VDI 2066	Three times a year	Spray dryer (whey protein concentrate) Steam Cyclone and bag filter steps before
130-3	4.20	NI	VDI 2066	Three times a year	Spray dryer (lactose) Steam Cyclone step before
131-1	6.10	6.20	NI	NI	Spray dryer (child nutrition, whole milk powder) Natural gas
296-2	7.60	NI	EN 13284-1	Four times a year	Fluidised bed dryer (powder) Coal Bag filter step before
130-4	15.00	NI	VDI 2066	Yearly	Fluidised bed dryer (lactose) Cyclone step before
254-2	19.30	NI	EN 13284-1	Yearly	Spray dryer (whey, microfiltration permeate) Natural gas Cyclone step before
295-4	51.30	NI	EN 13284-1	NI	Spray dryer (yeast extract powder) Steam Bag filter step before
NB: NI = no information provided. Source: [193, TWG 2015]					

Reference literature

[193, TWG 2015]

6 ETHANOL PRODUCTION

6.1 General information about the sector

Ethanol is manufactured by fermenting sugars into alcohol. The EU ethanol sector uses sugar from a wide variety of crops such as wheat, maize, barley, rye, triticale, and intermediates, co-products and residues from sugar beet and cereal starch production processes. Of these, the most commonly used are wheat, beet and maize, with the planting and harvesting ratio depending on market conditions. As ethanol is produced from processed crops and organic materials, it is referred to as renewable ethanol. The ethanol distilleries are generally integrated with sugar and starch factories; consequently, they also produce food, feed and fertilisers.

The annual European ethanol production is 6 420 billion litres (5 100 000 tonnes), from cereals (62.4 %), sugar from beets and molasses (25.4 %) and others (12.2 %).

Ethanol has many different properties and can be used in a wide range of products such as beverages, pharmaceuticals, cosmetics, and, increasingly, as a renewable transport fuel and for other uses. The essential uses of ethanol are food (30 %) and fuel and other industrial uses (70 %). Moreover, the solvent and preservative qualities of ethanol are in high demand. Ethanol is used for its solubilising properties, its miscibility with water and its very low odour. Its antiseptic properties are also sought after (disinfectant for external use), or its astringent and refreshing properties.

Ethanol of agricultural origin is used in different sectors: spirituous beverages, vinegar, cosmetics and perfumery, pharmaceutical and many others. Depending on their destination, several alcohol grades are manufactured, as seen in Table 6.1.

Table 6.1: Types of ethanol by industrial sector

Industrial sector	Dehydrated food ethanol	Food ethanol
Cosmetology, screen Wash, parachemistry	X	X
Pharmaceutical	X	X
Food (vinegar)	-	X
Food (sugar)	X	-
Spirituos beverages and culinary preparations	-	X
<i>Source:</i> [198, FoodDrinkEurope 2015]		

In the case of alcohol for medical purposes (called denatured alcohol), ethanol is mixed with substances that make it unpleasant. The physico-chemical characteristics of ethanol make it an excellent support in drugs including cough medicines, decongestants, and many more. As a solvent, the pharmaceutical industry uses it for the manufacture of antibiotics, vaccines, lozenges, tablets and vitamins.

6.2 Applied processes and techniques

Ethanol of agricultural origin is obtained by distilling:

- fermented raw materials containing fermentable sugars;
- fermentable sugars from hydrolysis of e.g. roots, stems, tubers, starchy materials, cellulosic material.

Derived from the fractional distillation of wine produced by fermentation, raw ethyl alcohol is then either rectified by fractional distillation processes to obtain superfine alcohol (for food, vinegar, cosmetics, and pharmaceuticals, for use as solvents or again in industrial applications), or is dehydrated for fuel purposes.

A simplified general scheme for the production of ethanol is presented in Figure 6.1.

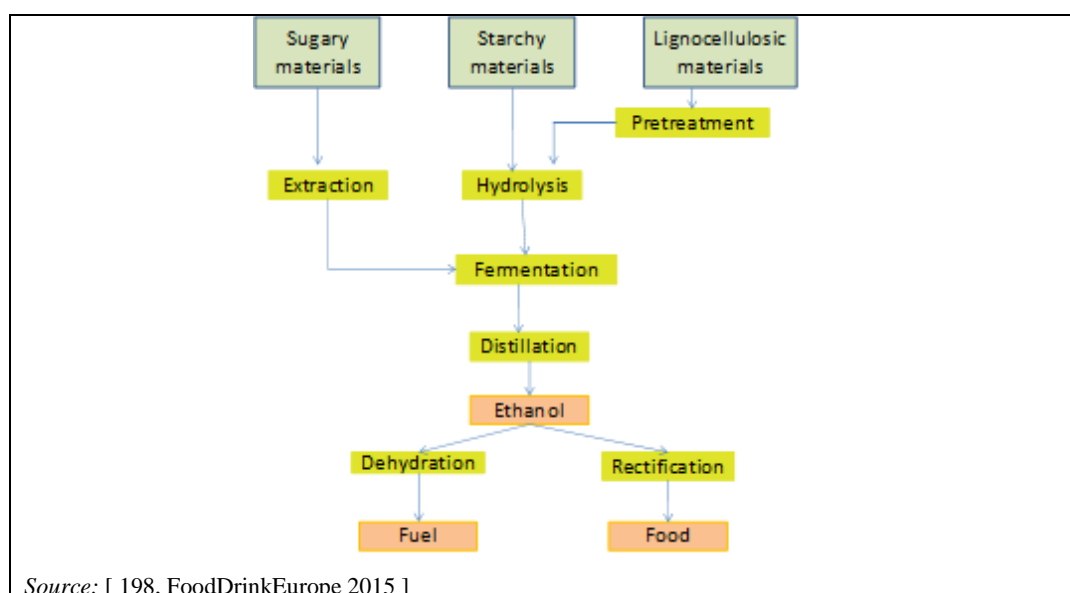

Figure 6.1: Ethanol production process

The main process steps are further analysed below [198,FoodDrinkEurope 2015].

Preparation of fermentable musts

Beets: the raw juice is simply acidified to enhance the hydrolysis of sucrose and to place the yeast in an environment that is favourable to it and not to microorganisms such as lactic and butyric acid. The sugar syrups are diluted and acidified.

Grains: the grain is milled and the flour obtained is liquefied, and saccharified by enzymatic action combined with thermal activity. The objective is to break down the glucosidic linkages of the starch macromolecule to obtain fermentable sugars. The grain is then pasted to allow enzymatic diffusion towards the starch molecules. The pasting is carefully carried out to avoid gelatinisation of the product. The industry also produces starch- and glucose-based products.

Starch crops require hydrolysis of carbohydrates to obtain glucose. The conversion from starch into glucose can happen by a double enzymatic process or a combined acid/enzymatic process. Lignocellulosic feedstock requires biochemical conversion of hemicellulose into sugars.

Fermentation

The purpose of this step is to produce an alcohol from the musts prepared from the various substrates described above. The breakdown of simple sugars into alcohol is normally referred to as alcoholic fermentation. Yeasts, usually *Saccharomyces sp.*, e.g. *cerevisiae* or *bayanus*, are used to produce ethanol from carbohydrates and very small amounts of other organic compounds. This conversion can be represented by the following equation:



This is an anaerobic process, i.e. it does not require the presence of oxygen. The temperature affects the rate of fermentation, the efficiency of conversion and the flavour and the aroma of the finished product. The fermentation temperature is maintained around 30–35 °C and the pH below 4.5 to prevent bacteria development.

Nitrogen, vitamins, salts and trace elements necessary for yeast development are used. Fermenters are cylindrical closed tanks, allowing CO₂ recovery. The fermentation can be continuous, semi-continuous or batch-operated. Selected strains of yeasts are often used to optimise the alcohol yield. Yeast is usually supplied to food ethanol and industrial ethanol manufacturers either in a crumbled/compressed/liquid form or as active dry yeast.

At the start of the process, the first tanks are ventilated to allow the yeast development by using air compressors and direct air injection in the tank bottom. At the end of the process, the fermentation to produce ethanol is strictly anaerobic.

Centrifugation of the whole or part of the process allows yeast recovery which can be recycled after an optional treatment at pH 2 by addition of strong acid (washing yeasts) which helps to get rid of the creams of centrifuged yeast bacteria. The alcohol obtained is 10–14 vol-%. The fermentation gases are washed to recover ethanol. CO₂ can also be exploited, when economically relevant.

More information about the fermentation technique can be found in Section 4.2.2.2.

Distillation

There may be numerous variations of the distillation process, depending on local production units. The process takes place in two basic types of equipment; the pot still and the column still. Stills may be operated singly or in groups. The addition of heat enables the separation of alcohol/aqueous compounds from the initial liquid feed in the still. Condensed aqueous alcohol is removed as a liquid spirit from the head of the still, whilst a residual stream is discharged from the base.

The pot still can be operated in a batch or continuous manner. In the former case, a batch of material is charged to the still pot, boiling is initiated, and the vapours are then continuously removed, condensed and collected until their average composition has reached a desired value. When operated in a continuous manner, feed is continuously passed to the still pot with the vapour and liquid portions being continuously removed.

In column distillation, the alcoholic liquid enters a distillation tower heated with vapour. In each contacting device, generally a tray, an equilibrium is created between the vapour enriched with volatile components and the condensed liquid. Crude alcohol is drawn off from the top of the tower and then rectified through another tower where 95 % of the alcohol is separated from higher alcohols. At the bottom of the first tower, an aqueous blend or stillage is drawn off. Condensed water or stillage water, contaminated slightly with organics, is drawn off at the bottom of the second tower once the alcohol has been dehydrated. The 95 % alcohol can be turned into anhydrous alcohol by a number of different technologies. These technologies can include azeotropic distillation using a third component, adsorption by a molecular sieve, or dehydration by a membrane technique. Some spirits and ethyl alcohols of agricultural origin can be distilled higher than 84 %.

The non-alcoholic fraction from the stills such as stillage, vinasse, pot ale, spent lees and spent wash is, to the extent possible, (re)used within the upstream process steps (e.g. liquifaction) to reduce the demand for fresh water. Excess spent lees and spent wash are discharged from the stills as waste water containing TSS and very high BOD levels. Emissions to air include TVOC and odour. There may be minor emissions of incondensable volatiles, mainly carbon dioxide and ethanol from column stills. There are no issues for pot stills.

Typically, stillage and other solid-containing fractions from distillation are intermediates from ethanol production further processed to co-products such as vinasse, concentrated stillage (CDS) or dried stillage (DDGS) which are used as animal feed or as a feedstock in sugar and grain-based production. Further uses of stillage and other solid-containing fractions from distillation include production of biogas (the gas being used for energy production) or irrigation/fertilisation (landspreading).

Two main representative examples are given below:

Example one: an alcoholic liquid is introduced into a distillation column, with an exhaustion part and a concentration part, making it possible to continuously separate the ethyl alcohol obtained in a liquid form, with an alcohol content of at least 90 vol-% after vapour condensation at the top of the column.

The columns have a high number of trays which represent distillation stages. The raw alcohol is then rectified and/or dehydrated. Continuous rectification consists of several columns in which fractioning allows for the classification and extraction of various impurities from the raw alcohol.

Typically, there is a purifying column or hydro-selection that runs at a low alcoholic degree, a distillation column operating at high alcoholic degree, a methanol extraction column, column concentration of 'mauvais goût' alcohol (this alcohol represents about 2–6 % of the raw alcohol used and is made up of various fractions withdrawn in the previous columns) and a refining column. Impurities are generally very soluble in alcohol and slightly soluble or insoluble in water. For this reason, it is very difficult to separate impurities from alcohol with a high alcohol content and therefore it is essential to dilute the raw alcohol to be rectified at the beginning of the rectifying process.

To separate the remaining water content, specific techniques are carried out like the use of a molecular sieve or the use of a third molecule (cyclohexane).

Example two: a distilling process follows four main steps: stripping, purification, rectification and dehydration.

In the stripping column, fermented raw material is heated to obtain a mixture of water and alcohol. Steam is commonly used for the heating. From this step, approximately 40–50 wt-% alcohol from the fermented raw material can be obtained.

This mix goes through a purification column to separate volatile compounds. The volatile compounds extracted from the purification column may be sent to an energy exploitation process or additional process. The bottom of the column is the main flow, with approximately 50 wt-% alcohol, to feed the rectification column. During this rectification step, the water is separated from the alcohol. In this step the water which comes from dehydration is also separated. The alcohol content during the extraction in the rectification column to the dehydration step is approximately 92 wt-% alcohol.

6.3 Current consumption and emission levels

6.3.1 Energy consumption

Distilleries require electrical and thermal energy for virtually every step of the process. Electricity is needed for lighting, for process control of the installation, for heating, for cooling and as the driving power for machinery. It can be generated and supplied by utility companies. Often steam and electricity are generated on site, given that the efficiency factor is considerably higher.

Thermal energy is needed for heating processing lines and buildings. The heat generated by the combustion of fossil fuels or biomass is transferred to the consumers by means of heat transfer media, which, depending on the requirements, are steam, hot water, and air. On-site combined generation of heat and power (CHP) is a valuable alternative for distilleries for which the heat and power loads are balanced. High-pressure steam boilers/steam turbines are used in distilleries. Natural gas, coal and biomass are the most convenient fuels.

In large distilleries, steam and electricity are generated using CHP plants. Small distilleries use boilers with different working pressures depending on the process needs and set-ups. Heat is needed for the conversion of starch to glucose, distillation columns, evaporation, drying and for sterilisation of tanks and pipelines. Depending on the process set-up, fresh steam or recovered steam is used.

Specific energy consumption values between 2 MWh and 8.5 MWh per tonne of product have been reported from three installations [193, TWG 2015]. The distillation tower is heated by steam. For pot stills, 12–13 kWh per litre of pure alcohol is required. Depending on the feedstock used and possible integration in an associated starch/sugar plant, the specific energy consumption can vary significantly.

6.3.2 Water consumption

The distillery sector needs water and often uses different qualities of process water for operation. A systematic approach is generally in place to control the use of water and to reduce water consumption and its contamination.

Each application of water requires its own specific quality. In the distillery sector, the quality requirements depend on whether or not contact between water and the food product is possible. This is normally incorporated in the hazard analysis and critical control point system (HACCP). The following sources of water are used in the distillery sector: tap water, groundwater, surface water, water originating from the raw material, recycled water and process water.

Most water consumption (around 70 %) is related to energy production: the boiler system which drives the plant and the cooling of process water and equipment. The rest (around 30 %) is for the fermentation process, feed treatment, and saccharification of starch. Water is very often recycled in the process [198, FoodDrinkEurope 2015].

Cooling water is needed to maintain the temperature of fermentation and to condense vapours. In distilleries, the cooling systems commonly applied are closed circulation cooling systems or cooling towers. In open cooling systems, i.e. cooling towers, not only does evaporation of the water occur but also a small part of the water could be sprayed.

Specific water consumption values between 2.94 m³ and 20.35 m³ per tonne of product have been reported by three installations (years 2012-2014) [193, TWG 2015]. Depending on the feedstock used and possible integration in an associated starch/sugar plant, the specific water consumption can vary significantly.

6.4 Techniques to consider in the determination of BAT

6.4.1 Techniques to reduce emissions to air

6.4.1.1 Carbon dioxide recovery and purification

See Section 4.4.4.3.

6.4.2 Techniques to reduce waste

6.4.2.1 Recovery and further processing of stillage distiller's dried grains with solubles

See also Section 2.3.5.2.

Description

Grain and beet vinasse are concentrated and added to the solid by-products before being dried for animal feed production.

Technical description

The alcohol is separated from the mash by distillation. The dealcoholised mash is called vinasse. The vinasse is dewatered by applying, variously, decanter centrifuges, evaporating and drying techniques. The water removed from the vinasse is partly (depending on the installation setup and its product portfolio) used as process water for other production steps, otherwise as waste water sent for waste water treatment.

The resulting vinasse can either be sold directly as distiller's grains with solubles (DGS) with a dry matter content ranging from about 32 % to 40 %, or be dewatered up to a dry matter content of about 90 % and it is then called distiller's dried grains with solubles (DDGS). It is typically used as animal feed and contains proteins, fibres, vitamins and minerals.

In the case of gluten and/or bran separation from the ground grain before the fermentation, the solid content of the stillage is lower. In these cases the stillage can be dewatered by applying only decanter centrifuges and evaporating techniques. The resulting product is called condensed distillers solubles (CDS) and is typically used as animal feed. It contains proteins, vitamins and minerals and has a dry matter content of 23–30 %.

Achieved environmental benefits

Less waste is produced.

Environmental performance and operational data

The temperature of the mixed liquid and solids before drying is about 70 °C and it is heated to 110 °C. The product has a temperature of about 30 °C. The evaporator is cleaned with sodium hydroxide, which can also be used to control the pH during the alcoholic fermentation. Some consumption information is shown in Table 6.2.

Table 6.2: Consumption data for the drying of DDGS

Parameter	Consumption/t DDGS produced
Vapour	4.5 t
Electrical energy	300 kWh
NaOH	15 kg
Water	0.1 m ³
<i>Source: [192, COM 2006]</i>	

Cross-media effects

Dust may be emitted when drying techniques are applied and energy is consumed. Odour may be emitted. Waste water is produced.

Technical considerations relevant to applicability

Applicable in alcohol manufacturing from grains.

Economics

The value of vinasse is exploited by the production of feed. The product can be sold for almost the same price as the grains.

Driving force for implementation

Without this recovery, the stillage residue needs to be disposed of.

Example plants

No information provided.

Reference literature

[92, Gergely E. 2003], [192, COM 2006], [198, FoodDrinkEurope 2015]

6.4.2.2 Recovery and (re)use of yeast after fermentation

See Sections 2.3.5.2 and 4.4.3.1.

The yeast may not be recovered when the stillage is used as animal feed.

7 FISH AND SHELLFISH PROCESSING

7.1 General information about the sector

This sector includes the processing of white or pelagic fish; fatty fish; shellfish, i.e. crustaceans and molluscs; and freshwater fish. Fish processing is very widespread and varied. Many species of fish are mass-processed, including cod, tuna, herring, mackerel, pollock, hake, haddock, salmon, anchovy and pilchards.

Increased seafood production is a crucial element of the solution to meeting the global food challenge. According to the Food and Agriculture Organization of the United Nations, capture fisheries and aquaculture supplied the world with about 158 million tonnes of fish and other aquatic species (around 136 million tonnes for human consumption) in 2012, providing an apparent per capita supply of 18.9 kg (see Figure 7.1). Of this total, aquaculture accounted for 42 %. During the past three decades, global aquaculture production has expanded from around 5 million tonnes in 1982 to over 66 million tonnes in 2012. Prognosis shows that in 2030 this is expected to have reached 93.6 million tonnes [205, Nordic Council of Ministers 2015].

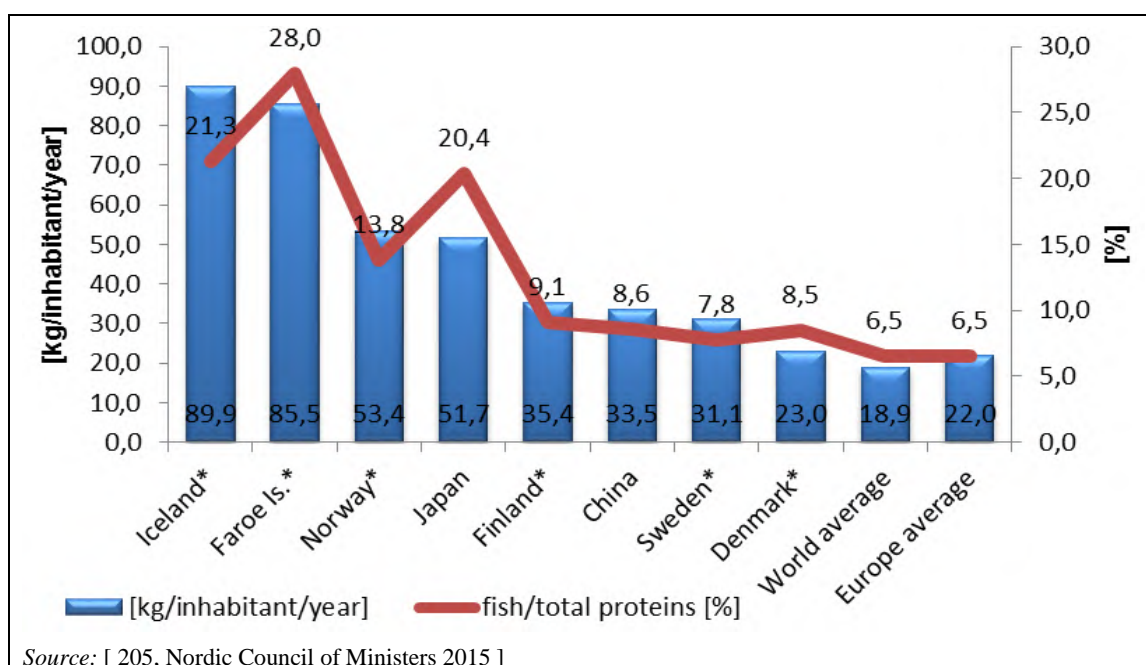

Figure 7.1: Fish and fishery products in live weight and fish contribution to protein supply (2012)

The EU is a major consumption market of seafood products in the world with 12.3 million tonnes, representing EUR 52.2 billion, in 2011 (see Figure 7.2). It is the first importer of seafood products, absorbing 24 % of total world exchanges in value. EU consumption per capita is 22 kg. Northern Member States are more focused on processed fish while southern Member States still favour fresh products and devote a larger part of household expenditures to fish. Central and Eastern European countries are below the EU average but have registered an increase in consumption [205, Nordic Council of Ministers 2015].

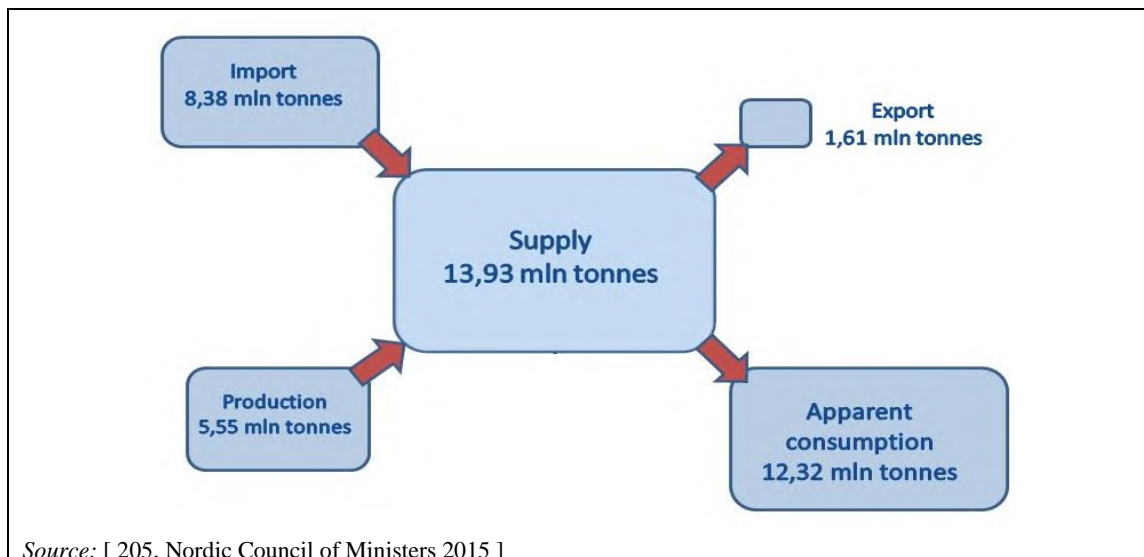

Figure 7.2: Seafood products balance in the EU in 2011 (live weight equivalent)

Fishery production in the Nordic countries is shown in Figure 7.3.

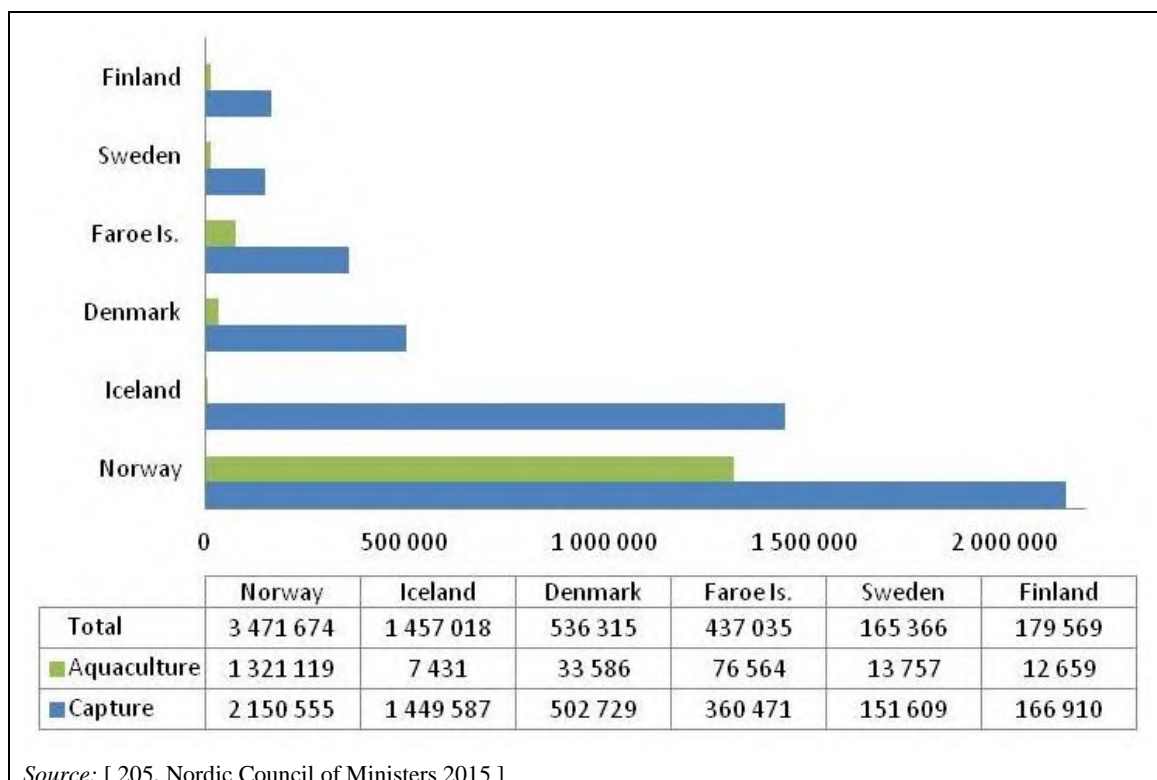

Figure 7.3: Fisheries production (tonnes) in Nordic countries by capture and aquaculture in 2012

EU exports are almost entirely composed of products from captured fisheries, whilst EU aquaculture products remain in the European market. EU exports to third countries increased by 50 % in value between 2009 and 2012 to reach EUR 4.1 billion. Spain, the Netherlands and Denmark are the leading Member States exporting to third countries. Table 7.1 shows the major suppliers of seafood to the European market.

Table 7.1: EU's main suppliers of seafood in 2012

Country	Value (thousand EUR)	Contribution (%)
Norway	3 874 711	20
China	1 565 995	8
Iceland	968 758	5
Ecuador	952 646	5
United States	873 906	5
Other suppliers	11 002 401	57
Total	19 238 417	100

Source: [205, Nordic Council of Ministers 2015]

The overall value of the output of the processing industry in the EU amounts to around EUR 30 billion. The United Kingdom, France, Spain, Italy and Germany are the leading countries in terms of production. The sector employs around 116 000 people. In 2012, the total number of enterprises in the European fish processing industry was 3 454. The mainstay of European production is conserves and ready meals of fish, crustaceans and molluscs.

7.2 Applied processes and techniques

7.2.1 General

Fish preliminary processing most commonly takes place at onshore processing facilities. However, some processing such as the gutting, cleaning and sometimes head removal of fish can take place at sea, on board fishing vessels, e.g. when processing white fish that has a low oil content.

The primary objective of any handling method is to preserve the quality of the fish by bringing the temperature down to close to 0 °C as quickly as possible. Factors such as delay in handling and chilling, poor temperature control in the fish hold, damage from rough handling, poor standards of gutting, bleeding and washing the fish, and mechanical damage due to the overfilling of the containers have a deleterious effect on the quality of the fish and result in a reduction of the shelf life and loss of weight.

A number of methods are used to preserve fish. Some employ techniques based on temperature control, using ice, refrigeration or freezing; others on the control of water activity and including drying, salting, smoking and freeze-drying. Techniques may rely on the physical control of microbial fish loads, such as canning, microwave heating or ionising radiation; or on chemical control of microbial activity and loads by adding acids, for example, to fish products. Techniques are also used that are based on decreasing the oxygen level, such as vacuum packaging. Most often, a combination of different techniques are used to preserve fish.

Freeze-drying or lyophilisation is the process of removing water from a product by sublimation and desorption. The aim of the process is to preserve sensitive material that cannot be dried by evaporation. There is a risk of degradation of specific components at high temperatures, which would result in a loss of taste or other quality aspects.

The freeze-drying equipment consists of a drying chamber with temperature-controlled shelves. This can be a batch chamber, where the trays remain fixed on the heating plates through the drying operation, or a semi-continuous type, in which the trays move through a vacuum lock into a drying tunnel. The equipment also includes a condenser, to trap water removed from the product in the drying chamber and to facilitate the drying process; a cooling system, to supply refrigerant to the shelves and the condenser, and a vacuum system to reduce the pressure in the chamber.

Fish processing plants make frequent use of flake ice, for example for wrapping/packing fresh fish and for transportation to wholesalers, retailers and restaurants. Flake ice can be purchased from a specialised ice plant and this way of working requires chilled transport of flake ice to the fish processing plant.

The solid material is then fed manually or mechanically onto the trays in a drying chamber. The temperature of the drying chamber is well below 0 °C. The exact temperature depends on the product being dried. A vacuum is applied in the chamber. The ice evaporates under these conditions. This evaporation causes a further decrease in the temperature of the product, which is compensated for by adding heat by means of heating plates to the product through the temperature-controlled trays. The evaporated water is refrozen on the surface of a condenser, which has a temperature well below the sublimation temperature under the existing conditions in the chamber. From time to time the condenser is de-iced by heating the condenser surface. The water is liquefied and drained. The vacuum is maintained by a vacuum pump. The outlet of the vacuum pump discharges into the air. To prevent solids entering and damaging the vacuum pump, a filter is usually applied in front of the pump.

Finally, fish processing operations include proper waste management techniques. The further processing of fish into a wide variety of value-added products is now common with the increase in demand for food products that are ready to eat or require little preparation before serving. For

the transportation of chilled and frozen fish products by road, rail, sea or air, it is essential that the cold chain is maintained throughout. This requires the use of insulated containers or transport vehicles and adequate quantities of coolants or mechanical refrigeration. Container technology now makes the combination of refrigeration combined with a modified or controlled atmosphere possible [205, Nordic Council of Ministers 2015].

7.2.2 Preliminary processing

7.2.2.1 General

Fresh fish received is inspected and adequately washed with potable water before processing. All fish received in a frozen state is either thawed promptly and processed or stored at a temperature that will maintain the fish in a frozen state. Thawing is carried out in as rapid a manner as possible so that the internal temperature of the fish does not exceed 3.3 °C.

The main objective of preliminary processing is the full or partial separation of edible parts from inedible ones. As a result, products are obtained of the shape, size and quality approved by the consumers and meet the needs of the further processing. It also allows for efficient utilisation of inedible parts, e.g. for animal feed production. Isolating the highly perishable parts extends the life of the parts used in further processing. The decrease of the mass of the raw material affords economy in the transport of the semi products or the final products.

There are a few major semi products of fish preprocessing from the least to the most labour-intensive: deheaded and gutted fish fillets, V-cut fillets, butterfly fillets, fish after nobbing. Subsequent operations result in the separation between edible and inedible parts. The choice of the particular form of preprocessing depends on the requirements of the technology, the kind and size of the material and the technical potential of the producer. The economic and marketing aspects are also of great importance.

In the modern fish industry, preliminary processing is mainly mechanised. There are special machines for scaling, gutting, deheading, nobbing, filleting, skinning, cutting and meat separation. In preprocessing processes, other machines are also used, e.g. freezers, de-icers or graders. There are many types of the aforementioned machinery. They differ in output capacity, size and species range of the processed material, the way in which the operation is performed, the technological yield, etc. Figure 7.4 and Figure 7.5 depict two different types of machines.

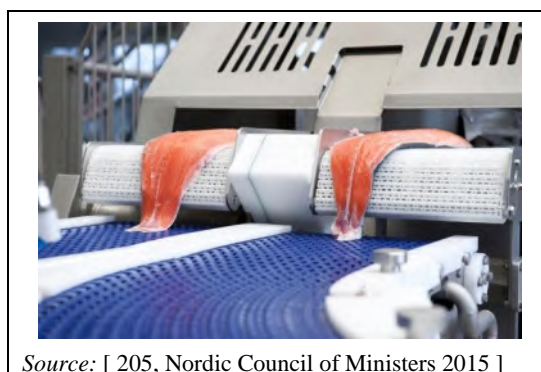

Source: [205, Nordic Council of Ministers 2015]

Figure 7.4: Salmon filleting machine



Figure 7.5: Heading, gutting and roe recovery machine

Most fish processing machinery installations used during preliminary processing depend for their operation on using large quantities of water. Beyond this necessary use of water, the flow of water to these installations is often uncontrolled and excessive. The waste is often cut or mashed up and mixed with the water by the action of the machines, which produces a highly polluted effluent. This is a particular problem when processing ungutted and high-oil-content pelagic fish. The solid waste from the machines is often not effectively separated at source. It frequently ends up on the floor around the installations. The faults lie not only in the processing machines themselves but also in the systems of catch trays, chutes, conveyors and flumes commonly built around them to transport the fish, products and waste [205, Nordic Council of Ministers 2015].

7.2.2.2 Freezing/Thawing

The freezing process alone is not a method of preservation. It is merely the means of preparing the fish for storage at a suitably low temperature. In order to produce a good product, freezing is accomplished quickly. A freezer needs to be specially designed for this purpose and thus freezing is a separate process to low-temperature storage. The three basic methods of freezing fish are: (i) blowing a continuous stream of cold air over the fish: air blast freezers; (ii) direct contact between the fish and a refrigerated surface: contact or plate freezers; (iii) immersion in or spraying with a refrigerated liquid: immersion or spray freezers. The majority of frozen fish semi products require thawing before further processing.

Thawing is the process of changing a product from frozen to unfrozen. It involves transferring heat to a frozen product to melt the ice that was formed within the flesh during the freezing process. The fish processing industry use a large quantity of frozen fish and shellfish every year. Much of this product requires thawing before further processing or use. Companies typically thaw seafood in-house using a range of different methods. These vary from using water (immersion or spray), air or steam through to microwave and radio frequency systems. After thawing, the fish shall be adequately washed with potable water before processing [205, Nordic Council of Ministers 2015].

The following sections describe some of the most commonly applied thawing processes.

7.2.2.2.1 Thawing using water recirculation and air stirring

The water used for thawing is recirculated in a closed circuit and used again. Air is used to stir the water during thawing. Level-actuated switches can be installed to control the amount of water fed into the tank. For shrimps and prawns, filtered peeling water can be used [71, AWARENET 2002], [94, Germany 2003].

7.2.2.2.2 Thawing in containers filled with warm water with air bubbles at the bottom

Thawing is carried out in containers filled with water at 30–35 °C, while air is bubbled in at the bottom. Level-actuated switches can be installed to control the amount of water fed into the tank. The water flow also affects the temperature. For shrimps and prawns, filtered peeling water can be used [13, Nordic Council of Ministers 1997], [71, AWARENET 2002].

7.2.2.2.3 Thawing by sprinkling

Thawing is achieved by sprinkling the food with water. Compared with thawing by immersion in running water, this technique consumes less water but requires longer times and larger surface areas [71, AWARENET 2002].

7.2.2.2.4 Thawing by 100 % water-saturated heated air

Thawing is achieved by exposing the food to 100 % water-saturated hot or warm air.

Compared with thawing by immersion in running water, this technique consumes less water but requires longer times and larger surface areas.

Using hot air may cause a rapid growth of microorganisms on the surface layers of the thawed product and hinder reabsorption of thawed water. This creates unsightly and often nutritionally wasteful drip loss. Furthermore, the food surface may dry and its unsaturated fats may oxidise. Energy consumption is higher compared to other thawing techniques, as hot air is used.

When warm humid air is used to thaw blocks of frozen white fish, it can cause problems in maintaining the quality of the finished product because the fish at the edge of the frozen block thaw before the fish in the middle of the block.

Dry thawing is reported to adversely affect the quality of shrimps and prawns [13, Nordic Council of Ministers 1997], [71, AWARENET 2002]

7.2.2.3 Grading

Processing begins with the grading of raw material according to species and size, as well as isolating the fish which are unfit for consumption or damaged. Fish grading is an absolute prerequisite for efficient industrial fish processing. The actual catch often contains fish of different sizes and species. Grading by size and separation of species ensures uniform flow for the next processes, thus increasing capacity and quality.

Fish grading is used extensively for small pelagic fish, e.g. herring, mackerel, sprat and sardines. The material is graded according to maximum thickness, as this is correlated with the length of the fish. Most frequently, the grading takes place in an opening slit formed by some vibrating elements, or between rotating rollers [205, Nordic Council of Ministers 2015].

A vibrating grading machine is shown in Figure 7.6.



Figure 7.6: Vibrating grading machine

7.2.2.4 Scaling

For some fish species, hand scaling takes up nearly 50 % of the initial processing time. Machines used in mechanised scaling should not damage the skin or weaken the texture of the muscular tissue. Two types of scaling machines are used in fish preliminary processing: drum machines in which the material is scaled by grazing the fish past the rough walls of the rotating drum, and machine scrapers in which the fish are passed through a system of stationary or moving scrapers [205, Nordic Council of Ministers 2015].

7.2.2.5 Deheading and gutting

The fish head constitutes up to 20 % of its weight and is usually considered an inedible part. The fish can be deheaded manually or mechanically. Manual cutting is easier for small freshwater fish. Larger fish ranging from 20 cm to 40 cm can be deheaded using mechanical devices. Fish can be cut in three different ways: round cut, straight cut and contoured cut. In most fish installations, manual deheading is performed because it causes minimal flesh loss. A cut around the operculum is called a round cut and it results in the lowest meat loss. This cut is mainly used when the final product is a boneless and skinless fillet. Machines with a guillotine cutter are suitable for larger fish undergoing round or contour cuts. Machines with a manually operated circular saw are suitable for larger fish undergoing straight cuts. The amount of deheaded waste produced from fish processing is 27–32 %.

Gutting of the fish is the removal of internal organs and optionally cleaning the body cavity of the peritoneum, kidney tissue and blood. In the gutting process, the fish is cut longitudinally to remove the internal organs on a table made of special material which is easy to wash and does not absorb fluids. The table is rinsed and periodically disinfected. There are some mechanical gutting machines used for trout, eel and other fish, but their use increases the fish processing cost. The internal organs constitute around 5–8 % of the fish weight [205, Nordic Council of Ministers 2015].

7.2.2.6 Filleting and skinning

Filleting can involve a number of unit operations: pretreatment, fish filleting, trimming of fillets, packing and storage. The fillet is the block of meat composed of the dorsal and abdominal muscles and the most popular form of fish-obtained culinary raw material on the market. The technological yield of filleting depends on the fish species, its sex, size, diet, etc. Hand filleting is labour-intensive and high productivity requires workers with considerable skill and experience. For this reason, filleting machines have been implemented in fish processing on a wide scale. Different species can be processed in these devices as long as they are in the same size range and have a similar body shape. The simplest filleting machine for gutted and deheaded fish has two disc knives set apart from each other at a distance equal to the thickness of the fish's backbone.

Following the wide application of filleting machines, skinning machines were introduced. The fish skinning machines are designed to scrape the fish skin from fish fillets and ensure a high output and effectiveness of the operation. A correctly skinned fillet should not be damaged on the skinned side, where the silvery pellicle-connecting monomers are left [205, Nordic Council of Ministers 2015].

7.2.3 Fish preservation methods

7.2.3.1 Canning

The canning process is a sterilisation technique that kills microorganisms already present in the fish, prevents further microbial contamination, and inactivates degradable enzymes. In this process, fish are hermetically sealed in containers and then heated to high temperatures for a given amount of time. The fish canning production process begins after filleting, when the fish is precooked in the cans; then brine, oil or sauce is added and finally the cans are sealed and autoclaved [205, Nordic Council of Ministers 2015].

7.2.3.2 Salting

Salting is the process that lowers the moisture or water content of fish and other fishery products to a point where microorganisms cannot live and grow. Sodium chloride, or salt, improves fish texture because it firms up the fish. Salt partially dehydrates the fish and kills the bacteria. Three basic methods of applying salt to preserve fish are as follows:

- Pickle salting – the fish are covered with salt and packed in layers in watertight containers. This forms the pickle that serves as the saturated brine solution that covers the fish completely.
- Brine salting – the fish are immersed in a saturated solution made up of 25 parts salt and 100 parts water. Brine salting is done only as a temporary way to preserve fish before they are dried, smoked or processed.
- Dry salting – granular salt is run over the fish. The proportion of salt to fish varies from 10 % to 35 % of the fish weight.

7.2.3.3 Smoking

Smoked seafood is prepared with two basic procedures. Hot smoking cooks the product; cold smoking does not. Cold smoking devices have one basic function: to apply smoke to the product. Hot smoking devices have the added function of applying heat. And because preservation of fish usually requires moisture removal, systems designed for hot or cold smoking of fish may have the added function of dehydration. Modern fish smoking equipment is usually designed to produce either hot or cold smoked products, but in either case they are

usually designed to have adequate airflow and exchange to remove large quantities of water from the product (and eject it from the system).

Before smoking, fish is dry-salted or brined in a manner that ensures an adequate and consistent water-phase salt content in the finished product. After removal from a brining solution, fish is rinsed with potable water. Immediately after the thermal process, the smoked fish is cooled to a temperature of around 3.3 °C or below and must remain at or below that temperature at all times, including through all storage, marketing, and sales channels [205, Nordic Council of Ministers 2015].

In general, the different smoking technologies can be summarised as follows:

- smoking food with combustion smoke (conventional smoke);
- smoking food with friction smoke (conventional smoke);
- smoking food with purified smoke.

Combustion smoke is smoke generated from sawdust or woodchips (of different particle sizes and different moisture contents) fed continuously or at intervals into a glow zone where they are ignited using heating wire and placed under an airstream for carbonising. The typical pyrolysis temperature is between 500 °C and 800 °C. Air purification systems are needed to reduce pollutants in the exhaust air.

Friction smoke is smoke generated from wooden blocks. A timber block is pressed onto a fast-rotating steel friction wheel. At the friction surface, smoke is generated by the increased temperature. The typical pyrolysis temperature is between 300 °C and 400 °C. In order to prevent the friction wood from igniting, the smoke generator operates in intervals. Purification systems for exhaust air are required.

Purified smoke is produced and used in the following stages:

- in a closed circuit, smoke is produced on the basis of primary products;
- thereby food produced is exposed to smoke in conventional smoking chambers.

The product resulting from applying purified smoke is similar to a product made with conventional smoking processes. Smoking with purified or regenerated smoke is a smoking process, as stated in the EU Regulation 1321/2013. The content of polycyclic aromatic hydrocarbons and 3-MCPD in the smoked product is minimised during the purified smoking process [32, CleanSmoke 2018].

Primary products (also known as liquid smoke flavourings) are produced (usually outside the FDM installation) in the following stages:

- in a closed system, smoke is produced on the basis of untreated sawdust of hardwood (the sawdust being a waste product of the wood industry);
- the smoke thereby produced is condensed in an aqueous substance (solution with drinking water);
- the smoky solution is filtered over several stages (removing ash, tar and PAHs).

The exhaust from the smoking kilns is treated using incineration. Energy consumption can be reduced using catalytic incineration and heat recuperation.

Tar is deposited on smoking sticks and in the smoking chamber. The sticks are cleaned in a constantly moving drum, which ensures that the sticks rub hard against each other to remove the deposits. The tar is then removed by a controlled water supply and not running water. Tar deposited in kilns or troughs is collected and handled as chemical waste and not in the WWTP.

Smoking frames are often cleaned manually with a pressure cleaner. A washing cabinet which collects and recirculates water containing detergents is used. The drain may automatically be changed over to the WWTP at the final rinse. As an alternative, a washing tunnel could be used with water from the second stage reused for the initial rinse.

Table 7.2 shows the environmental impact of the different methods of smoke generation.

Table 7.2: Environmental impact of the different methods of smoke generation

	Emissions to air	Air treatment	Tar deposits	Cleaning (water consumption/waste water pollution)
Burning wood	Large content of TVOC	Needed	Large content	Water consumed and waste water produced due to cleaning
Smouldering wood	Up to 200 chemical components	Needed	Large content	Water consumed and waste water produced due to cleaning
Purified smoke	Limited	Unnecessary	No deposits	Reduced; powerful detergents are not needed
Friction smoke	Reduced	Reduced	Reduced	Reduced; powerful detergents are not needed
Superheated steam	Reduced	Needed	Large content (ends up in waste water)	Waste water contains tar
<i>Source:</i> [2, IED Forum 2018] [17, TWG 2018] [32, CleanSmoke 2018] [192, COM 2006]				

7.2.3.4 Drying

Like the salting method, drying lowers the water content of the fish to a point where microorganisms, bacteria, enzymes and yeasts cannot grow and multiply. The most popular fish preservation method is solar drying (natural dehydration). It is done in combination with salting. Fish dried under the sun looks and tastes better.

7.3 Current consumption and emission levels

7.3.1 Overview

Major environmental impacts associated with fish processing operations are the high consumption of water, consumption of energy and the discharge of a waste water with a high organic concentration due to the presence of oils, proteins and TSS. Waste water can also contain high levels of phosphates, nitrates and chloride. Noise, odour and solid wastes may also be concerns for some installations. In addition to this, due to the highly perishable nature of fish compared to other FDM products, if not properly refrigerated, product yield decreases and product losses contribute to the solid and liquid waste loads. These solids may be used in fishmeal production. The consumption and emission of the utilities (water, energy) vary widely depending on the process technology, product characteristics, installation location, equipment characteristics and source of utilities. Table 7.3 summarises the environmental impact of the processes applied in this sector.

Table 7.3: Environmental impact of processes of the fish processing industry

Process	Environmental impact						
	Water consumption	Waste water generation	Energy consumption	Waste generation	Odour	Noise	Chemical consumption
Preliminary processing	+	+	+	+	-	+	-
Thawing/frizzing	+	+	+	-	-	-	-
Grading	-	-	+	-	-	-	-
Scaling	+	+	+	+	-	-	-
Deheading and gutting	+	+	+	+	-	-	-
Filleting and skinning	+	+	+	+	-	-	-
Canning	+	+	+	+	+	-	+
Salting	+	+		-	-	-	+
Smoking	+	+	+	-	+	-	-
Drying	-	-	+	-	+	-	-
Cleaning	+	+	-	+	-	-	+

NB:
 + = potential environmental impact.
 - = non-existent/no relevant environmental impact.
 Source: [205, Nordic Council of Ministers 2015]

Table 7.4 shows the inputs and outputs of different types of fish production.

Table 7.4: Inputs and outputs of different types of fish production (per 1 000 kg of fish)

Process	Inputs	Outputs					
	Energy (kWh)	Waste water (m ³)	BO D (kg)	COD (kg)	Nitrogen (kg)	Phosphorus (kg)	Solid waste (kg)
Filleting of white fish	Ice: 10–12 Freezing: 50–70 Filleting: 5	5–11	35	50	NI	NI	Skin: 40–50 Heads: 210–250 Bones: 240–340
Filleting of oily fish	Ice: 10–12 Freezing: 50–70 Filleting: 2–5	5–8	50	85	2.5	0.1–0.3	400–450
Thawing of frozen fish	NI	5	NI	1–7	NI	NI	NI
De-icing and washing	0.8–1.2	1	NI	0.7–4.9	NI	NI	0–20
Grinding	0.1–0.3	0.3–0.4	NI	0.4–1.7	NI	NI	0–20
Scaling of white fish	0.1–0.3	10–15	NI	NI	NI	NI	Scales: 20–40
Deheading of white fish	0.3–0.8	1	NI	2–4	NI	NI	Head and debris: 270–320
Filleting of deheaded white fish	1.8	1–3	NI	4–12	NI	NI	Fish frames and offcuts
Filleting of ungutted oily fish	0.7–2.2	1–2	NI	7–5	NI	NI	Entrails, tails, heads and fish frames: 400
Skinning of white fish	0.4–0.9	0.2–0.6	NI	1.7–5	NI	NI	Skin: 40
Skinning of oily fish	0.2–0.4	0.2–0.9	NI	3–5	NI	NI	Skin: 40
Trimming and cutting of white fish	0.3–3	0.1	NI	NI	NI	NI	NI
Packaging of fillets	5–7.5	NI	NI	NI	NI	NI	NI
Freezing and storage	10–14	NI	NI	NI	NI	NI	NI
Handling and storage of fish	10–12	NI	NI	130–140	NI	NI	NI
Unloading of fish	3	2–5	NI	27–34	NI	NI	NI

NB: NI = no information provided.
Source: [205, Nordic Council of Ministers 2015]

7.3.2 Energy consumption

Fish processing facilities need energy to produce hot water, steam and electricity for process and cleaning applications. Electricity is used for electrical equipment, air conditioning, cooling, freezing, and ice production. Energy consumption can be divided into two parts: approximately 80 % of energy consumption depends on production and 20 % is constant and independent of production [205, Nordic Council of Ministers 2015].

The consumption of energy depends on the installation, the equipment and the fish manufacturing processes that take place. Processes, e.g. canning, that involve heating, cooling, production of ice, drying, evaporation and oil production consume more energy than those that do not, e.g. filleting, where energy consumption is low. On average, filleting consumes 65–87 kWh/t of fish while canning consumes 150–190 kWh/t of fish [192, COM 2006].

7.3.3 Water consumption

Fish processing requires large amounts of water, primarily for washing and cleaning purposes, but also as a medium for storage and refrigeration of fish products before and during processes. Water is also an important medium for transportation in the particular handling and processing steps. The processing industry for marine species often uses seawater in part of the cleaning process, and cleaning the fish fillet with seawater is considered important to improve the quality of the finished product. Seawater used for this purpose is normally filtered and treated with UV disinfection to inhibit spread of bacteria.

Fish canning and fish filleting consume large quantities of water, e.g. to clean and lubricate the filleting machinery. Typical figures for fresh water consumption are: for thawing, about 1 m³/t of fish; for filleting, 5–11 m³/t of fish; and for canning, 15 m³/t of fish. Water is used for transporting fish and viscera, for cleaning the installation and the equipment, for washing raw materials and products, and for thawing. Reported water consumption and specific COD loads for traditional fish processing are summarised in Table 7.5.

Table 7.5: Specific water consumption and organic load in Nordic countries

Production	Water consumption (m ³ /t raw fish)	COD (kg/t raw fish)
Herring filleting	3.3–10	Up to 95
Mackerel processing	NI	NI
Cleaning and head cut	20	270
Thawing included	26–32	NI
White fish processing	NI	NI
Fresh fish processing	4.8	5–36
Thawing included	9.8	NI
Shrimp processing	23–32	100–130
NB: NI = no information provided. Source: [13, Nordic Council of Ministers 1997]		

7.3.4 Emissions to water

Water consumption in the fish processing industry and the production of highly polluted waste water are of great concern worldwide. In fact, in this type of industries, a huge amount of water is used throughout all steps, including cleaning, cooking, cooling, sanitisation and floor washing. Most of the water consumed during fish processing becomes waste water. The

process-related waste water is produced in different processing steps, e.g. thawing, washing, head cutting, filleting, skinning and trimming, and in cleaning the equipment and the installation.

Fish processing waste water is known to contain organic contaminants in soluble, colloidal and particulate form. The biodegradable organic matter is mainly in the form of proteins and lipids. The concentration and volume of waste water from fish processing varies widely, depending on the fish to be processed, the additives used (e.g. brine, oil, tomato sauce), the unit processes involved and the source of the water, among other factors.

When frozen fish is used as a raw material, a thawing step is needed. The organic pollution of the waste water is relatively small. Scaling normally takes place in rotating perforated drums. Scales are flushed away using large amounts of water – 10–15 m³/t of fish. Large volumes of waste water and organic pollution are generated. If the fillets are to be skinned, scaling is not necessary. In automated filleting and eviscerating processes, water is used to lubricate fish while passing through the machine. For some species such as mackerel, a warm caustic bath is necessary to remove the skin and the waste water needs to be neutralised before it is discharged.

Water is used for washing and rinsing the fish, giving rise to waste water carrying fish scraps and viscera. Viscera from oily fish contain high emission levels of oil and soluble matter, thus waste water from their filleting normally has higher COD levels (3 000–60 000 mg/l) than that from white fish filleting (2 000–6 000 mg/l). The highly polluted waste water is generated due to the time that solid wastes are in contact with the water which contains blood and fat. In automated skinning, the fillet is pulled over a freezing drum. Water is used to clean and lubricate the machine. The skinning of fatty fish releases large quantities of oil to the waste water. The skinning process contributes about one third of the overall organic pollution in the waste water of filleting installations.

As the evisceration of fatty fish takes place at the processing installation, and white fish are eviscerated at sea, this also adds to the reason for the waste water having higher COD and TSS levels. Table 7.6 shows the reported waste water characteristics from fish filleting.

Table 7.6: Waste water characteristics from fish filleting

Parameter	Filleting of herring		Filleting of cod	
	Average (kg/m ³)	Range (kg/m ³)	Concentration (kg/m ³)	Load (kg/t fish)
BOD ₇	10 000	5 000–20 000	600–1300	8–19
Fat	12 000	2 500–16 000	50–70	0.3–1.4
Dry matter	20 000	5 000–28 000	NI	NI
Protein	6 000	NI	NI	NI
Total nitrogen	NI	NI	100–600	0.3–3.1
Suspended solids	NI	NI	NI	1.6–11.3
Water consumption (m ³ /t)	NI	5	NI	NI

NB: NI = no information provided.
Source: [71, AWARENET 2002]

In precooking, water is reused several times and can be recovered. About 3–4 g oil/kg of fatty fish, protein and pieces of fish are released into the water with the oil forming a layer on the surface. If the fish is made in brine, there is a high salt concentration in the waste water. Skin is removed from some species, such as mackerel, with the help of a warm caustic bath. Waste water is consequently alkaline and is treated by neutralisation.

The waste water contains blood, flesh, guts, soluble protein and waste material and is high in BOD, COD, TSS, FOG and phosphates, as well as detergents and other cleaning agents.

Table 7.7 shows the characteristics of untreated waste water from the fish sector and its primary treatment efficiencies.

Table 7.7: Characteristics of untreated fish industry waste water and primary treatment efficiencies

Treatment method	BOD (mg/l)	Total N (mg/l)	Total P (mg/l)	FOG (mg/l)
Untreated	2 000–28 000	400–1 000	80–150	500–25 000
Centrifugation	1 500–5 000	NI	NI	500–2 000
DAF	1 500–6 000	200–600	40–90	400–2 000
Precipitation (H ₂ SO ₄) and DAF	800–3 000	150–300	30–50	100–500
Precipitation (Fe/Mo) and polyelectrolyte	600–3 000	150–300	5–10	100–500
Two-step DAF with precipitation (Fe/Mo) and polyelectrolyte	500–1 500	100–200	5–10	50–300
NB: NI = no information provided. Source: [71, AWARENET 2002]				

Waste water production rates and characteristics largely depend on the production lines. Data for Germany are presented in Table 7.8.

Table 7.8: Typical waste water production rates and characteristics for fish processing in Germany

Production	Waste water production (m ³ /t)	TSS (mg/l)	BOD ₅ (mg/l)	Fats* (mg/l)
Herring	17–40	220–1 520	2 300–4 000	190–450
Fresh fish	About 8	170–3 650	1 000–6 250	46–2 500
Smoking of fish	About 8	14–845	1 000–1 700	24–180
Salting of salmon	About 35	NI	NI	NI
Deep-frozen fish	2–15	NI	NI	NI
Thawing	NI	0–70	30–1 800	4–46
* Expressed as petrolether extract. NB: NI = no information provided. Source: [12, ATV 2000]				

Fish processing waste water is generally treated using physico-chemical methods (primary treatment), biological methods (secondary treatment), or a combination of both. Primary treatments include processes such as equalisation, screening, sedimentation, pH adjustment, flocculation, flotation and microfiltration. The biological processes (aerobic and anaerobic) are known to be more appropriate for removal of dissolved organics and nutrients.

A stepwise approach to waste water treatment commonly yields the best results in the most economical way. The primary treatment deals with the removal of suspended solids, colloidal materials and large screenable and settleable solids. In the treatment of fish processing waste water solids and colloids, they should be removed quickly and with low-shear technologies in order to avoid dissolution of oil and organics (COD) into the water. Waste water treatment is a provision to collect the substances lost during the process as it is the last possibility for pollution control and a good opportunity for recovering valuable substances.

The hardness of the water received by fish processing plants (via drinking water supply companies) for their production process affects the chloride concentration in their waste water.

By supplying soft water to these plants (but also to other plants), the chloride concentration will decrease. If drinking water or grey water is produced from hard water, it is better to soften it centrally at sites where increased salt concentrations have no harmful effects on the receiving watercourse.

More information on emissions to water can be found in Section 2.2.3.

7.3.5 Emissions to air

Dust, carbon monoxide, polycyclic aromatic hydrocarbons, organic acids, acrolein, acetaldehyde, formaldehyde, nitrogen oxides and, most importantly, total volatile organic compounds have been identified as pollutants associated with smokehouses.

7.3.5.1 Odour

Odour is often a significant form of air pollution in fish processing. Major sources include storage sites for processing waste, cooking of by-products during fish drying processes, and odour emitted during filling and emptying of bulk tanks and silos. Fish quality may deteriorate under the anaerobic conditions found in storage in fish processing facilities. This deterioration causes the formation of odorous compounds such as ammonia, mercaptans, and hydrogen sulphide gas.

The largest odour source in the fish by-products segment is the fishmeal dryers. Odorous gases from reduction cookers consist primarily of hydrogen sulphide (H₂S) and trimethylamine [(CH₃)₃N], but are emitted from this stage in appreciably smaller volumes than from fishmeal dryers. The canning processes also release some odours. Fish cannery and fish by-product processing odours can be controlled by means of afterburners, chlorinator-scrubbers, or condensers [205, Nordic Council of Ministers 2015]. The vented smoke also contains VOC. Some installations remove odours from the smoke before it is emitted to the air.

7.3.6 Solid output

The amount of waste from fish varies with fish species, size, season and fishing ground. The solid waste is generated when the fish is gutted, deheaded and further processed into fillets. Depending on the efficiency of the production process, only 50–60 % of the total fish catch goes for human consumption. The waste includes heads, viscera, skin, trimmings and fish rejects. It is often dumped, used as animal feed or as fertiliser. Due to the worldwide decline of fish stocks, a better use of by-catch and by-products is important. These types of biomass have great potential as a source of high-value products due to their high protein content and high levels of essential nutrients such as vitamins, minerals and fish oils.

Part of the waste water and almost all of the solid output may be used for different purposes. Fatty acids and flavours may be recovered from cooking water. Rejected fish are used in animal feed or for production of fishmeal and fish oil and used afterwards in foodstuff, animal feed and coatings.

By-products from the filleting, skinning, cutting and canning steps are used for:

- production of foodstuffs, e.g. fishmeal, ingredients, surimi, polyunsaturated fatty acids, gelatine and collagen;
- production of animal feed, e.g. fish protein, fish silage, fish protein hydrolysate, pet food, fish oil and solubles;
- production of fertilisers such as fish solubles and fish protein hydrolysate;
- production of pharmaceuticals such as gelatine and collagen;
- production of coatings, e.g. fish oil and pearl essence, and adhesives such as fish glue;
- production of leather.

Fluid lost from the fish may be treated anaerobically to produce biogas. Heads, shells, intestines and scraps have different applications, such as:

- production of animal feed, e.g. fishmeal, crustacean meal for cats and astaxanthin for aquaculture;
- production of foodstuff, e.g. fishmeal, chitin and chitosan;
- production of flocculants for waste water treatment, e.g. chitin and chitosan;
- production of pharmaceuticals, e.g. chitin and chitosan.

Solid by-products of the filleting, curing, salting and smoking of fish have similar uses to those mentioned above for the canning of fish. Ash from shavings is generally disposed of with municipal solid waste.

7.4 Techniques to consider in the determination of BAT

7.4.1 Techniques to reduce water consumption

7.4.1.1 General processing techniques

7.4.1.1.1 Removal of fat and viscera by vacuum

Description

Use of vacuum suction instead of water to remove fat and viscera from the fish.

Technical description

In skinning and cutting, enclosed systems are applied for transporting fat and viscera to collection facilities. The fat and viscera are removed from the fish by vacuum and not with water. The sucking equipment consists of a vacuum ending in a specially designed sucking nozzle placed immediately after the head cut.

Achieved environmental benefits

Reduced water consumption. Reduced waste water pollution. Waste minimisation, e.g. by-products can be sold for fishmeal production.

Environmental performance and operational data

Reductions of 30–50 % of the pollutant load are achieved. The energy consumed is higher than for the traditional removal of the head by cutting and washing out the viscera.

Cross-media effects

Energy consumption and noise pollution.

Technical considerations relevant to applicability

Applicable in the fish sector, e.g. during cutting, eviscerating and filleting.

Economics

This technique permits savings in waste water treatment. As the by-product has a lower water content, it can be sold at a higher price.

Driving force for implementation

Economic savings in waste water treatment.

Example plants

Used in mackerel processing in the Nordic countries.

Reference literature

[13, Nordic Council of Ministers 1997], [71, AWARENET 2002]

7.4.1.1.2 Use of the filtered recirculated scaling waste water for preliminary fish rinsing

See also Section 2.3.3.1.1.

Description

Scaling waste water is filtered and recirculated for preliminary fish rinsing.

Technical description

Scaling equipment consists of a perforated rotating drum onto which water is applied to flush scales away. Using the filtered recirculated scaling waste water for preliminary fish rinsing minimises overall water consumption. Proper adjustment of the scaler operation, by weighing the amount of scales for a specific water flow, is also carried out.

Achieved environmental benefits

Reduced water consumption.

Environmental performance and operational data

Water savings of up to 70 % are reported.

Cross-media effects

Energy consumption for reusing the scaling water.

Technical considerations relevant to applicability

Applicable in the fish sector.

Economics

No information provided.

Driving force for implementation

Economic savings in waste water treatment.

Example plants

No information provided.

Technical considerations relevant to applicability

Applicable in the fish sector.

Reference literature

[71, AWARENET 2002]

7.4.1.1.3 Avoidance of scaling if the fish is subsequently skinned

Description

Avoidance of scaling if the fish is subsequently skinned.

Technical description

Scaling equipment consists of a perforated rotating drum onto which water is applied to flush scales away. If the fish is subsequently skinned, scaling is not carried out.

Achieved environmental benefits

Reduced water consumption. Reduced energy consumption.

Environmental performance and operational data

Water savings of 10–15 m³/t are achieved.

Cross-media effects

No information provided.

Technical considerations relevant to applicability

Applicable in the fish sector.

Economics

No information provided.

Driving force for implementation

Economic savings in waste water treatment.

Example plants

No information provided.

Reference literature

[71, AWARENET 2002]

7.4.1.1.4 Dry transport of fat, viscera, skin and fillets**Description**

Use of conveyors instead of water.

Technical description

Instead of using transport water in filleting, skinning and fat and viscera removal, a conveyor can either be set up under each line or a single filtering conveyor can serve all the machines. The dry transport is carried out by a chute, with a slope of approximately 20 %, mounted under the gutting wheel. Here viscera, fatty belly strips and the water from the wheel are caught. The method used on a filleting machine is shown in Figure 7.7. From the chute, viscera strips and water slide on to a fine meshed synthetic cloth conveyor belt, through which the water is drained. The viscera are transported to a container.

In filleting of white fish, dry transport is carried out by a filter conveyor with a mesh size of 0.25 mm. The water from the machines and small particles pass through the filter, while solids, e.g. fat and viscera, are retained. To keep the equipment clean and preserve filter capacity, it may be necessary to mount a water spray system. The filtrate can be used as spray water.

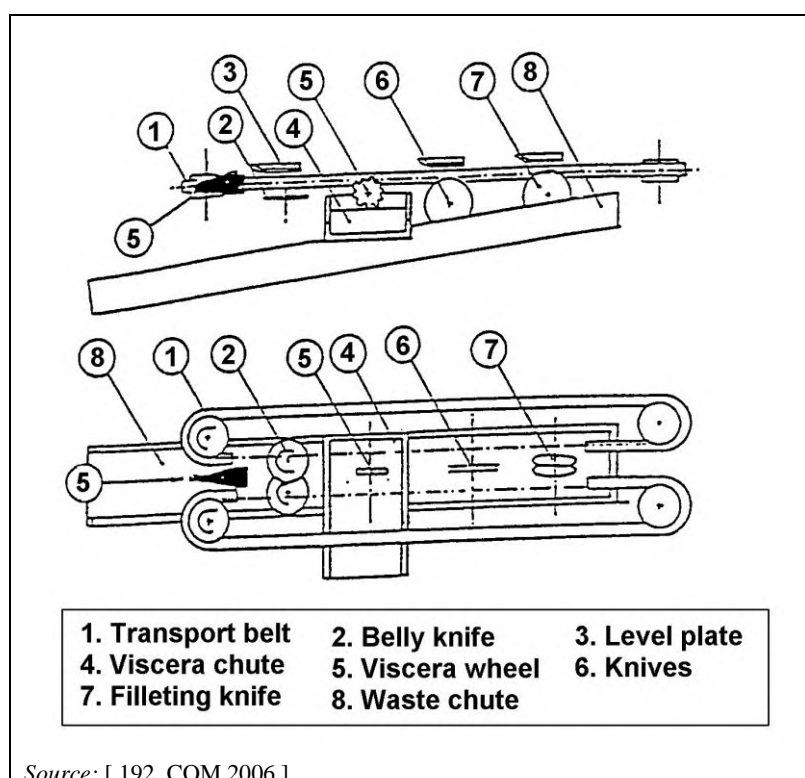

Figure 7.7: Equipment used for the dry removal of viscera

Achieved environmental benefits

Reduced waste water pollutant load. Waste minimisation, e.g. a large amount of saleable by-product is collected, which can be sold for fishmeal production.

Environmental performance and operational data

The pollution load of the waste water is reduced by 29–52 %, as shown in Table 7.9.

Table 7.9: Discharge data before and after introduction of dry removal and transport of viscera

Parameter	Wet (kg/t raw herring)	Dry (kg/t raw herring)	Reduction (%)
Total nitrogen	1.4	0.99	30
Total phosphorus	0.17	0.12	29
COD	26.3	15.0	43
Dry material	17.8	10.9	39
Oil	7.3	3.5	52
<i>Source:</i> [192, COM 2006]			

Filter conveyors under filleting machines are estimated to decrease the total COD discharge by about 5–15 % if the installation has a central filter conveyor or by about 15–25 % if it has a drum sieve.

Cross-media effects

Water consumption, e.g. for cooling the equipment's knives and wheels, for cleaning the filter belt, and for cleaning the belly cavity. Energy is consumed.

Technical considerations relevant to applicability

Applicable in the fish sector, e.g. during skinning, evisceration, filleting and cutting.

Economics

As the by-product has a lower water content, it can be sold at a higher price.

Driving force for implementation

Economic savings in waste water treatment.

Example plants

Used in the Danish herring industry, in white fish processing in the Nordic countries and in the fish processing industry in the UK.

Reference literature

[13, Nordic Council of Ministers 1997], [28, Envirowise (UK) 1999], [192, COM 2006]

7.4.1.2 Techniques related to cleaning

7.4.1.2.1 Dry cleaning

This technique is described in Section 2.3.3.2.1.

Environmental performance and operational data

Dry systems for collecting solid waste from crustacean and mollusc processing, such as screens and efficient recovery systems, prevent it from entering the WWTP and can reportedly lead to BOD₅ reductions of up to 35 %.

Another example is the use of a suction device which sucks the skinner drum clean of skin and fat.

Technical considerations relevant to applicability

Applicable to all fish and seafood processing installations.

Reference literature

[71, AWARENET 2002]

7.4.2 Techniques to reduce waste

7.4.2.1 Separation of residues

This technique is described in Section 2.3.5.3.

There are likely to be many other opportunities to apply this technique within the sector. For example, for the application of dry collection of all solid wastes by means of trays or baskets to prevent them from falling on the floor and entering the WWTP.

Technical considerations relevant to applicability

Applicable to all fish and seafood processing installations.

Reference literature

[71, AWARENET 2002]

7.4.2.2 Use of only high-quality fish

Description

High-quality fish can be selected for fillets to increase the process yield.

Technical description

When the fish quality is poor, soft fillets can get caught in the skinning knife. This decreases the yield of the process and increases the generation of by-products and waste. Skinning of fatty fish releases large quantities of oil to the waste water, amounting to about a third of the overall TOC or COD load. Water is used to clean and lubricate the machinery. Maintaining the sharpness of skinning knives also makes a significant contribution to efficient skinning and waste minimisation.

Fish can deteriorate under the anaerobic conditions present during storage on the fishing vessel, so ensuring rapid delivery and processing, as well as providing storage conditions which maintain quality, contributes to maintaining high quality. The fish are stored in ice, while at sea. On land, they may be stored on ice and sometimes in refrigerated storage. The method of storage may depend on the time interval between the fish being caught and subsequent processing. High-quality fish can be selected for fillets and lower-quality fish can be used in fishmeal and fish oil production for example. Broken fish may be used for food which does not require the appearance of whole fillets, such as moulded products and soups.

The successful application of this technique depends on collaboration with the operators of the fishing vessels and intermediary holders of the fish, such as wholesalers and hauliers.

Achieved environmental benefits

Reduced waste generation.

Environmental performance and operational data

No information provided.

Cross-media effects

Energy may be required for storage.

Technical considerations relevant to applicability

Applicable in fish processing.

Economics

No information provided.

Driving force for implementation

Reduced waste generation.

Example plants

No information provided.

Reference literature

[13, Nordic Council of Ministers 1997], [71, AWARENET 2002]

7.4.3 Techniques to reduce emissions to air

7.4.3.1 Techniques to reduce TVOC emissions from smoke kilns and odour

7.4.3.1.1 Use of purified smoke

Description

Smoke generated from purified primary smoke condensates is used to smoke the product in a smoke chamber.

Technical description

The conventional smoking methods apply the smoke to the goods directly after the combustion, while in the purified smoke method a step is added in-between. In this step, the smoke is treated in a liquid phase for cleaning purposes (e.g. to remove undesired and harmful substances such as tar and ashes). Using compressed air, the purified smoke is afterwards regenerated as smoke in a closed circuit and applied through the air to the goods to be smoked.

Purified smoke is different to liquid smoke and is produced and used in the following stages:

- in a closed circuit, smoke is produced on the basis of primary products;
- food is exposed to the smoke thereby produced as in a conventional smoking process.

Primary products are produced in the following stages [32, CleanSmoke 2018]:

- in a closed system, smoke is produced on the basis of untreated sawdust of hardwood (the sawdust being a waste product of the wood industry);
- the smoke thereby produced is condensed in an aqueous substance (solution with drinking water);
- the smoky solution is filtered over several stages (removing ash, tar and PAHs).

In more detail, the purified smoke process begins with a combustion process, whereby untreated high-quality woodchips from sawmills are smouldered in a controlled pyrolysis process. Water is added to the smoke produced, so that the freshly developed smoke can be processed. When the smoke and water are brought together, phase separation takes place during the resultant dispersion. The undesirable tars sink down and settle. This tar phase is separated through sedimentation and filtering, and used for energy production. The remaining part is the precleaned primary smoke condensate. The precleaned primary smoke condensate is a dispersion, and therefore contains liquid and solid substances. In order to produce aromatic smoke from the primary smoke condensate, a mixture must be formed from the gas phase, droplet phase (< 50 µm) and solid phase.

Precisely metered compressed air and precleaned primary smoke condensate are fed into a two-substance nozzle under a pressure of at least 5.0 bar. With the output of the compressed air/primary smoke condensate mixture, a pressure drop to atmospheric pressure takes place, and with this kinetic energy is released. This kinetic energy results in the compressed air/primary smoke condensate mixture solubilising in ultra-fine droplets, through partial evaporation of

particularly volatile components in a gas phase and solids. Measurements have shown that the maximum droplet size under the specified parameters is 5 µm. A total of 85 % of the droplets formed exhibit a size of < 1 µm [32, CleanSmoke 2018].

Achieved environmental benefits

Low emissions to air. Reduced water consumption.

Environmental performance and operational data

Purified smoke is carried out in enclosed smoking chambers, thus no emissions to air are generated [76, CleanSmoke 2017].

The production process of the precleaned primary smoke condensate and the smoking process in a closed system together lead to resource preservation and conservation of the environment. When compared to conventional smoked goods, purified smoke has the potential to reduce [32, CleanSmoke 2018]:

- water consumption by 92 %;
- CO₂ emissions by 83 %;
- waste water by 83 %;
- cleaning detergents consumption by 68 %.

Cross-media effects

No information provided.

Technical considerations relevant to applicability

Applicable in the processing of fish and seafood and meat products.

Economics

No information provided.

Driving force for implementation

Reduction of tar content in the smoked product.

Example plants

Applied in several installations in the fish and meat sectors of Sweden, France, Belgium and Germany [32, CleanSmoke 2018].

Reference literature

[2, IED Forum 2018], [32, CleanSmoke 2018], [69, Layman 2015], [76, CleanSmoke 2017]

7.4.3.1.2 Biofilter

For general information, see Section 2.3.7.3.4.

Environmental performance and operational data

In a Norwegian salmon installation, a biofilter dimensioned for 3 000 m³ air/h is installed inside an insulated cassette. The biomedica consists of non-degradable compounds and after the biofilter application no bad smell was detectable in the local environment [224, Denmark 2015].

Reference literature

[224, Denmark 2015]

7.4.3.1.3 Non-thermal plasma treatment

General information on the technique is given in Section 2.3.7.3.8

Environmental performance and operational data

Table 7.10 shows data for some fishmeal example installations.

Table 7.10: Odour reduction using non-thermal plasma treatment

Industry	Number of samples	Odour in (average) (OU_E/m^3)	Odour out (average) (OU_E/m^3)	Average (range) reduction efficiency (%)
Fishmeal	3	15 833	3 233	80 (± 4)
Fishmeal	3	16 350	1 600	90 (± 1)

Source: [192, COM 2006]

Reference literature

[192, COM 2006]

7.4.3.1.4 Thermal oxidation of waste gases

General information on the technique is given in Section 2.3.7.3.6.

Environmental performance and operational data

At an example smokehouse with an annual production of around 3 000 tonnes of smoked products, waste gases from smoking are burned using a direct flame thermal oxidiser. The waste gas from the smokeless process phases, which does not require emission abatement, is not treated. The system is regarded as a robust waste gas treatment requiring little maintenance.

The thermal oxidiser is heated to its operating temperature before the smoke generators are operated. During smoking, the exhaust gas fan force-feeds the smoke-laden waste gas through a waste gas bypass flap to a preheater. Here, the dirty gas is heated to 300–350 °C before it enters the combustion chamber, where it is mixed with the hot gases from the gas burner. After treatment, the clean gas is used to preheat the dirty gas by using an integrated heat exchanger and it is cooled to 400–450 °C before it is discharged to air via a flue stack.

Table 7.11 shows technical data for direct flame thermal oxidation in the example smokehouse. A flow diagram of the origin and process management of hot gas from this smokehouse is illustrated in Figure 7.8.

Table 7.11: Technical data of a direct flame thermal oxidiser applied in a smokehouse

Dimensions	
Total length including burner	4 250 mm
Total length excluding burner	3 750 mm
Diameter	1 150 mm
Dirty gas connection	200 x 200 mm or 200 mm diameter
Clean gas connection	300 mm
Weight	Approximately 1 250 kg
Rated connections	
Fuel	Oil
Electrical connection	220 V/50 Hz (approximately 1 kW)
Exhaust gas fan	380 V/50 Hz (approximately 4 kW)

Source: [192, COM 2006]

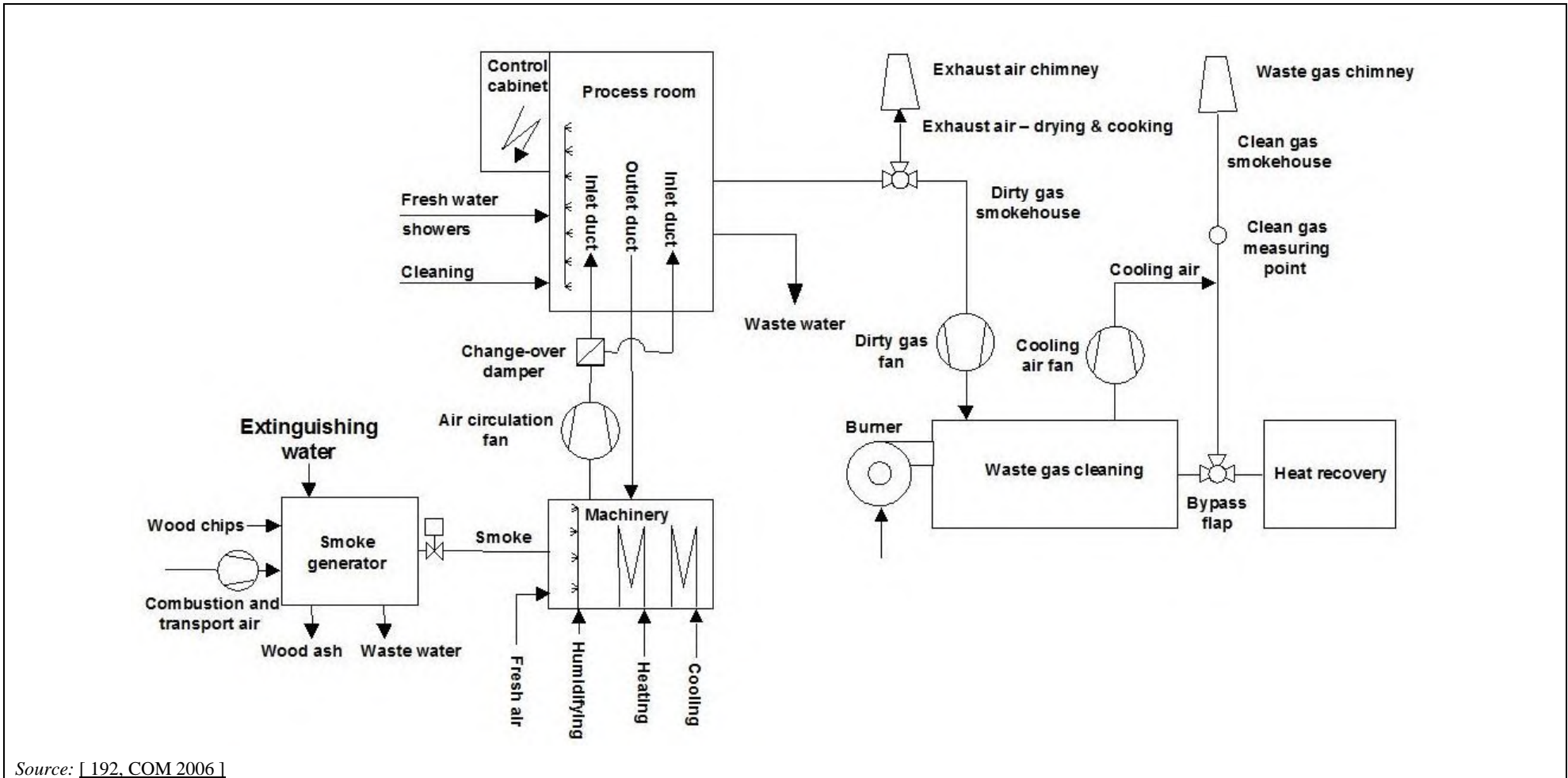

Figure 7.8: Flow diagram showing the origin and process management of the hot gas from the waste gas cleaning system of a smokehouse

In the example smokehouse, all smoke units, regardless of their size, are equipped with a smoke generator. The smoking intensity is determined by the smoking time which is approximately 60–120 minutes/batch. The flow rate for one smoke generator is 200 Nm³/h, resulting in a total flow rate for 11 smoke chambers of approximately 2 300 Nm³/h. Applying a realistic parallel operating factor of 75 %, the actual flow rate is 1 650 Nm³/h. Table 7.12 shows technical data for the direct flame thermal oxidiser used.

Table 7.12: Technical data for a direct flame thermal oxidiser applied in a smokehouse

Parameter	Value	Comments
Waste gas flow rate	2 300 m ³ /h	Normal state (i.e. 0 °C, and 1 013 mbar, dry)
Burner capacity	600 kW	The capacity is continuously modulated
Substance concentration in waste gas	Achieved level not reported (< 50 mg/Nm ³ TOC ≤ 0.115 kg/h)	2 300 Nm ³ /h x 50 mg/Nm ³ = 0.115 kg/h
<i>Source: [192, COM 2006]</i>		

It is reported that at 620–660 °C, complete removal of odour emissions is achieved and, as a general rule, TOC is emitted at an unspecified level below 50 mg/Nm³. Direct flame thermal oxidation can be run at temperatures of up to 1 000 °C. The effectiveness of the technique depends on several parameters such as operating temperature, residence time and mixing conditions in the combustion chamber. TOC emission levels of less than 10 mg/Nm³ are readily achieved.

Figure 7.9 shows the balance of substances as an input/output diagram for the waste gas treatment system.

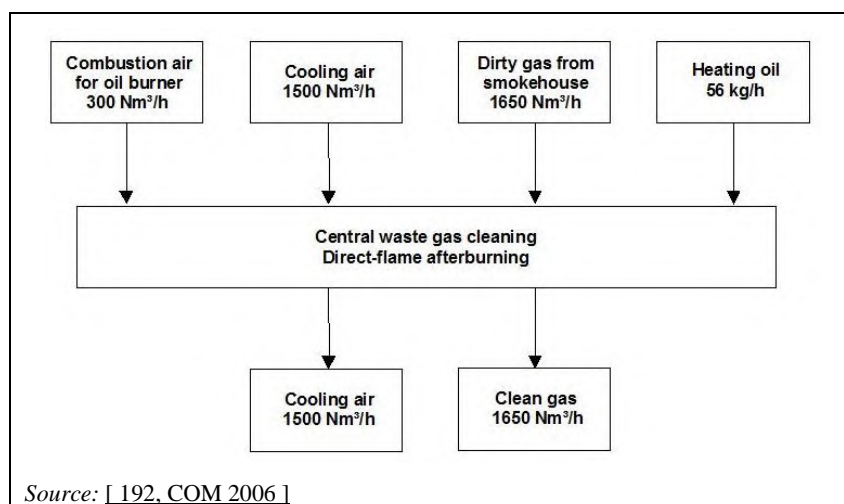

Figure 7.9: Mass balance of a waste gas treatment system with direct flame thermal oxidation

Additional data (2017 measurements) from German installations (that did not participate in the data collection) are presented in Table 7.13.

Table 7.13: Periodic measurements of TVOC emissions to air from a smoke kiln after thermal oxidation

ID	TVOC (mg/Nm ³)	CO (g/Nm ³)	NO _x (g/Nm ³)	Smoking method	Additional information
DE-SmK-02 (2009 data)	43	0.36	0.05	NI (fish)	- O ₂ content 17.5 % - Thermal oxidiser temperature 712–732 °C
DE-SmK-03 (2011 data)	1) 15.1 2) 17.4 3) 17.5	NI	NI	Smouldering of wood chips (Mackerel fish)	- Half hourly averages - O ₂ contents 1) 16.3 % 2) 16.5 % 3) 16.6 % Thermal oxidiser temperature 680–710 °C

NB: NI = no information provided.
Source: [60, Germany 2017]

Reference literature

[60, Germany 2017], [192, COM 2006]

7.4.3.1.5 Wet scrubber and electrostatic precipitator

General information on wet scrubbers is given in Section 2.3.7.3.1. An electrostatic precipitator is commonly used as a pretreatment step.

Environmental performance and operational data

Data from a German installation (that did not participate in the data collection) are presented in Table 7.14.

An alkaline scrubbing solution was used. Before scrubbing, air emissions were treated in an electrostatic precipitator. Smouldering of woodchips was used as the smoking method.

Table 7.14: Periodic measurements of TVOC emissions to air from a smoke kiln after wet scrubbing

ID	TVOC (mg/Nm ³)	TVOC (kg/h)	Products	Additional information
SmK-07 (2016 data)	Silica gel method: 1) 29.8 2) 24.4 3) 22.0	Silica gel method: 1) 0.082 2) 0.085 3) 0.063	Salmon, trout	Half-hourly averages 4 chambers with 2 trolleys for cold smoking 2 chambers with 2 trolleys for hot smoking

Source: [60, Germany 2017]

Reference literature

[60, Germany 2017]

8 FRUIT AND VEGETABLES

8.1 General information about the sector

The EU produces a broad range of fruit and vegetables thanks to its varied climatic and topographic conditions. It is one of the main global producers of tomatoes for example. The EU-28 produced an estimated 16.8 million tonnes of tomatoes in 2014, of which approximately two thirds came from Italy and Spain.

The EU-28 also produced an estimated 5.5 million tonnes of carrots and 6.4 million tonnes of onions in 2014. Carrot production was relatively high in Poland and the United Kingdom; these two countries accounted for more than one quarter (14.2 % and 14.9 % respectively) of EU-28 output in 2014. The Netherlands and Spain are the EU's principal onion-producing countries, accounting together for a little over two fifths (46.0 %) of EU-28 output in 2014.

Around 14 million tonnes of apples were produced in the EU-28 in 2014. Apples are produced in almost all EU Member States, although Poland, Italy and France are by far the largest producers. Citrus fruit production in the EU is much more restricted by climatic conditions; the vast majority of citrus fruits (59.8 %) are produced in Spain [[218, Eurostat 2015](#)].

Europe is also the second grower of potatoes worldwide; it is an industry well rooted in the agricultural supply chain across Europe. The whole of Europe grows 122 million tonnes of potatoes and processes 52 million tonnes of potatoes per year. The sector's turnover is EUR 8 billion.

Besides being consumed directly and traded as raw commodities, fruit and vegetables are processed into a multitude of food products, which can be grouped into frozen and preserved fruit and vegetables (canned vegetables, jams, marmalades and dried fruits) (71.7 %), juices (19.5 %), tomato ketchup (3.7 %), prepared meals (3.6 %) and drained fruits and homogenised vegetables and fruits (1.5 %). Fruit and vegetable processing took place mainly in five Member States, which were responsible for over two thirds (67.4 %) of the total value of production in 2015. The leading Member States were Italy (18.9 %) and Spain (14.5 %), which alone produced over one third of the total value. They were followed by Germany (11.8 %), France (11.35 %) and the United Kingdom (11.0 %) [[54, EUPPA 2018](#)].

8.2 Applied processes and techniques

The characteristic features of fruit and vegetables are that they are soft edible plant products which, because of their relatively high moisture content, are perishable in their fresh state. A summary of the possible processing routes of some fruit and vegetables is shown in Table 8.1.

Table 8.1: Summary of the possible processing routes of some fruit and vegetables

	Raw material	Processing	Preservation method
Garden vegetables	Peas, beans, spinach, potatoes, asparagus, maize and lentils	Put in packaging, in water	Thermal treatment
	Olives, cabbage, artichokes, mushrooms, onions, peppers, carrots and cucumbers	Put in oil, pickling/brining, sulphited	Natural or artificial thermal treatment
	Cabbage and cucumbers	Lactic acid fermentation	Microbial treatment
	Various garden vegetables	Juice	Thermal treatment
	Various garden vegetables	Dried	Drying
	Various garden vegetables	Freezing, deep-frozen and ready-to-use vegetables	Cooling
Tomato	Tomato	Paste	Dehydration and heat treatment
		Whole peeled	Thermal treatment
		Non-whole, peeled (diced or crushed)	Thermal treatment
		Juice, strained, passata	Thermal treatment
		Powder and flakes	Drying
Fruit	Berries, pears, apples, peaches, apricots, plums, pineapple, cherries and grapes	Put in water, in syrup	Thermal treatment, with optional synergetic action of sugar (reduction of a_w)
	Peaches, apricots, plums, cherries, berries and figs	Jam and jellies	Thermal treatment, with optional synergetic action of sugar (reduction of a_w)
	Citrus	Marmalade	Thermal treatment, with optional synergetic action of sugar (reduction of a_w)
	Pears, apples, peaches, apricots, plums, tropical fruits and undergrowth fruits	Juices and nectars	Thermal treatment
	Various fruits	Candies	Action of sugar (reduction of a_w)
	Various fruits	Concentrates	Thermal treatment (reduction of a_w)
	Various fruits	Put in alcohol	Reduction of a_w
	Various fruits	Dried fruits	Drying
	Various fruits	Frozen and deep-frozen fruit	Freezing
Potatoes		Put in water	Thermal treatment
		Put in oil	Freezing, cooling
		Flakes and granulates	Drying

Source: [52, Italy 2001], [54, EUPPA 2018]

Some common processes applied in the fruit and vegetable sectors are first described in the following sections. Then some more details are given for specific products.

8.2.1 Peeling

The objective of peeling is to remove the skin/peel from raw fruit and vegetables. This improves the appearance and taste of the final product. During peeling, the losses need to be minimised by removing as little of the underlying food as possible but still achieving a clean peeled surface. Various methods for peeling are steam peeling, knife peeling, abrasion peeling, caustic peeling and flame peeling. These various methods are chosen depending on the type of fruit or vegetable and the intended end product.

In most peeling operations, a water spray is used to remove the peeled skin. Waste water is generated which contains TSS. Conventional steam or hot water peeling uses large quantities of water, up to four times that required for caustic peeling, and produces waste water with high levels of product residue. At potato processing installations, the peels, if not collected, can contribute considerably to the total BOD. Dry caustic peeling methods can greatly reduce the volume and pollutant load of the waste water from this operation and allow for the collection of peel as pumpable slurry. The use of caustic in peeling may lead to pH fluctuations in the waste water. Some produce, e.g. tomatoes, requires strong caustic solutions and the addition of wetting agents. Dry caustic peeling tends to have a lower caustic consumption than wet methods. In steam peeling, most of the peeled material is discharged with the steam; this results in the collection of a concentrated waste stream. Remaining traces are sprayed off with water or with brushes. However, the brushes can cause damage or microbiological contamination. The process has lower water consumption than other wet peeling methods.

When flame peeling is applied, some dust and odour emissions can occur. The peels are often recovered and used as animal feed; otherwise they are disposed of as waste. Abrasion peeling has a significantly higher product loss than flash steam peeling, 25 % loss compared to 8–15 % loss, and considerably more waste water is produced. In caustic peeling, product loss is around 17 %. Dry caustic peeling reduces water consumption and produces a concentrated caustic paste for disposal.

Flash steam peeling, caustic peeling and flame peeling require heat; the other peeling operations use electrical energy.

The most common peeling processes that are applied in the fruit and vegetable sector are described in more detail in the following subsections [1, CIAA 2002], [8, Environment Agency of England and Wales 2000], [14, VITO et al. 2001], [15, Van Bael J. 1998], [23, Envirowise (UK) and Ashact 2001], [66, Italy 2002], [94, Germany 2003], [110, CIAA 2003], [116, CIAA-AAC-UFE 2003], [138, Fellows P.J. 2000], [160, Federación Conservas 2005].

8.2.1.1 Steam peeling – continuous process

The continuous steam peeler is a drum with a screw inside. The steam is fed directly into the drum, generally at a lower pressure than the batch process (see Section 8.2.1.2), and the product is heated during an adjustable residence time. Most of the peeled material is discharged with the steam. Any remaining traces are sprayed off with water or with brushes. However, the brushes can cause damage or microbiological contamination. This water may be filtered and used to wash raw fruit and vegetables.

With this process, reduced waste production, compared to other peeling techniques, is achieved, and the peel is often recovered and used as animal feed. Moreover, less water is used than in a combination of abrasion and knife peeling.

Steam peeling uses approximately five times more steam, e.g. for energy, than caustic peeling. Table 8.2 shows energy carriers and consumption for steam peeling, prior to freezing vegetables.

Table 8.2: Energy carriers and consumption for steam peeling, prior to freezing vegetables

Energy carrier	Approximate consumption
Hot water (kWh/t frozen vegetables)	0
Steam (t/t frozen vegetables)	0.9
Steam pressure (bar)	7–15
Electricity (kWh/t frozen vegetables)	3.5
<i>Source: [192, COM 2006]</i>	

Steam peeling uses large quantities of water, up to five times more than the amount required for caustic peeling, but half of that for a combination of abrasion and knife peeling. It also produces waste water with high levels of product residue. At potato processing installations, the peels can contribute up to 80 % of the total BOD. In fruit processing, peeling waste water can account for as much as 10 % of the total waste water flow and 60 % of the BOD. When steam peeling is applied, cold water may be used to condense the steam. If water cooling is not used then less water is used, less waste is produced and there are lower organic loads in the waste water. Product loss in the peeling process is 8–15 %.

The waste consists of the solid peel residues as well as dissolved substances such as starch or tissue fluids. The solid material is generally separated by sedimentation, dried and composted. This fraction contains minerals and bioactive phenolic substances, but also, in the case of potatoes, glycoalkaloids which limit the direct nutritional use.

The steam peeling process in an example potato processing installation is shown in Figure 8.1.

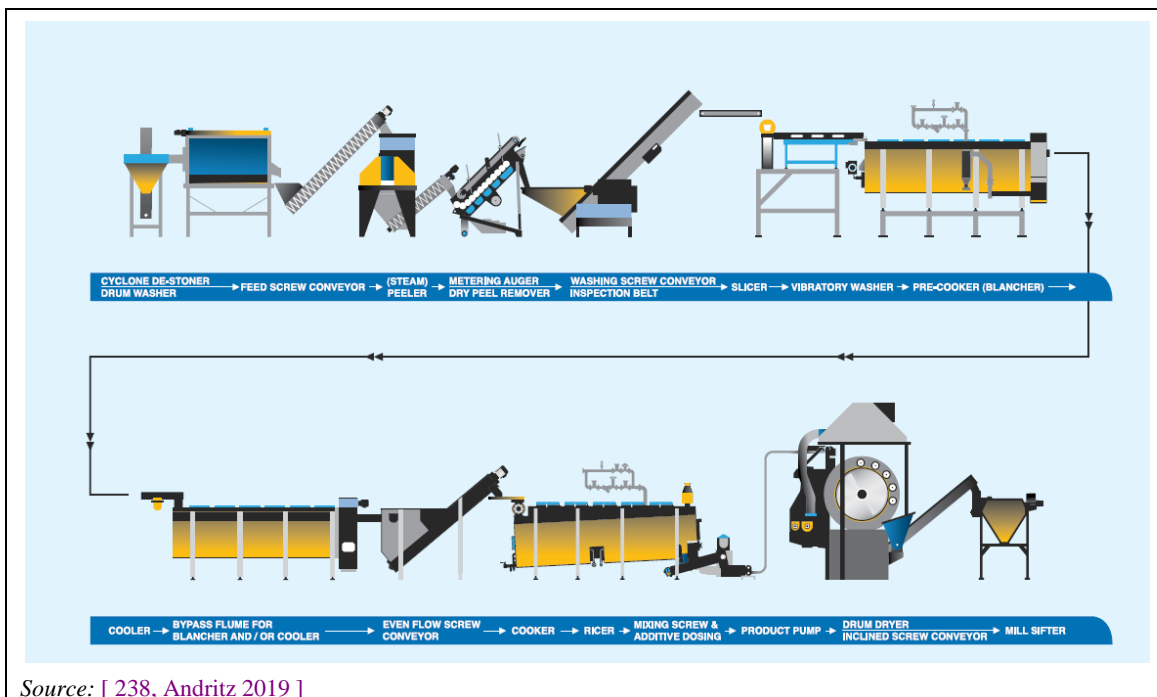

Source: [238, Andritz 2019]

Figure 8.1: Steam peeling process in an example potato processing installation

8.2.1.2 Steam peeling – batch process

Batch steam peeling is also called flash steam peeling. The raw materials such as roots and tubers are exposed to high-pressure steam, from 1 500 kPa to 2 000 kPa in a rotating pressure vessel. The high temperature causes a rapid heating and cooking of the surface layer within 15 to 30 seconds. The pressure is then instantly released, which causes the cooked skin to flash off.

Most of the peeled material is discharged with the steam. Water or brushes are only needed to remove any remaining traces. However, the brushes can cause damage or microbiological contamination.

Reduced water consumption and waste water production, in comparison to continuous steam peeling, is achieved, but with increased levels of product residue. Reduced waste production, compared to other peeling techniques, is achieved and the peel is often recovered and used as animal feed.

The process has lower water consumption and waste water production than continuous steam peeling. With tomatoes, the pressure used ranges from 200 kPa to 350 kPa. This type of peeler is reportedly gaining in popularity due to the lower water consumption, minimum product loss, good appearance of the peeled surfaces and the possible high throughput of up to 4 500 kg/h, with automatic control of the peeling cycle.

In Figure 8.2 the fast steam peeling process is depicted.

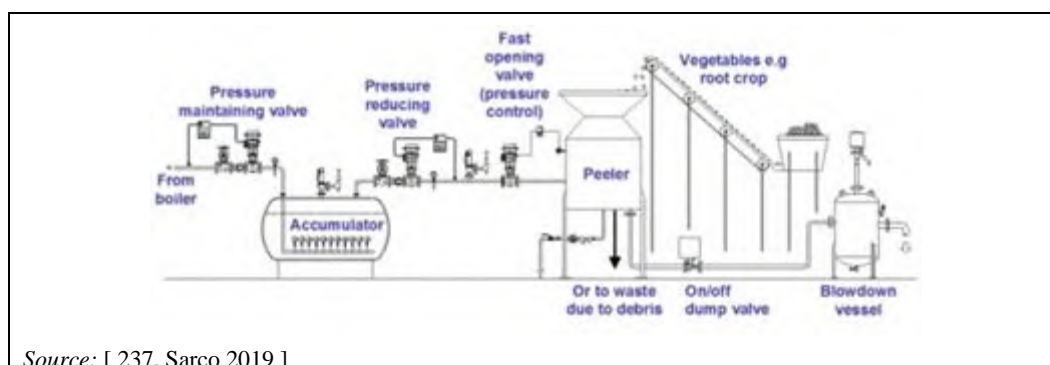

Source: [237, Sarco 2019]

Figure 8.2: Fast steam peeling

8.2.1.3 Abrasion peeling

In abrasion peeling, the material to be peeled is fed onto carborundum rollers or fed into a rotating bowl which is lined with carborundum. The abrasive carborundum surface removes the skin, which is then washed away with a copious supply of water. The process is normally carried out at ambient temperature.

Energy is not required for heating water or producing steam, but is needed for the operation of the rollers or rotating bowl.

The relatively low throughputs are due to all of the pieces of food needing to contact the abrasive surfaces. The hygiene quality is sometimes a problem because, as no peeling water is added, the cooling function of water is not fulfilled, and there can be localised high temperatures. Nevertheless, the quality of potatoes can reportedly be maintained during peeling using carborundum.

Large quantities of water are consumed. There is high product loss and high production of waste water. Odour emissions can be a problem. A combination of abrasion peeling and knife peeling produces a higher waste water pollution load than steam peeling. The peel can be recovered and used as animal feed.

8.2.1.4 Knife peeling

In knife peeling, the material to be peeled is pressed against rotating blades, or is itself rotated against stationary blades. Although water is not used during the actual peeling operation, it is used for the continuous cleaning of rollers and blades, so contaminated waste water is produced.

The peel can be recovered and used directly as animal feed or for recovery of its components. The energy consumption is lower than for steam peeling.

The product loss after knife peeling is 16–17 %. Maintaining the knife sharp reduces damage to the product and consequent waste. After cutting, defective pieces, e.g. which are too dark or too small, can be separated and used as animal feed. In carrot processing, several valuable substances such as vitamin C, fibre, phenolic compounds and carotenoids, can be recovered as by-products.

Table 8.3 shows the effect of a combination of abrasion pre-peeling and knife peeling on water pollution in the production of half pears in syrup.

Table 8.3: The effect of a combination of abrasion pre-peeling and knife peeling on water pollution loads in the production of half pears in syrup

	BOD (kg/t)	COD (kg/t)	SS (kg/t)
Abrasion pre-peeling plus knife peeling	21.6	36.5	21.5
NB: Water consumption if the water is not reused for cooling cans after sterilisation: 29.6 m ³ /t. Water consumption if the water is reused for cooling cans after sterilisation: 6.2 m ³ /t. <i>Source: [192, COM 2006]</i>			

Figure 8.3 shows a typical flow diagram of fruit and vegetable canning.

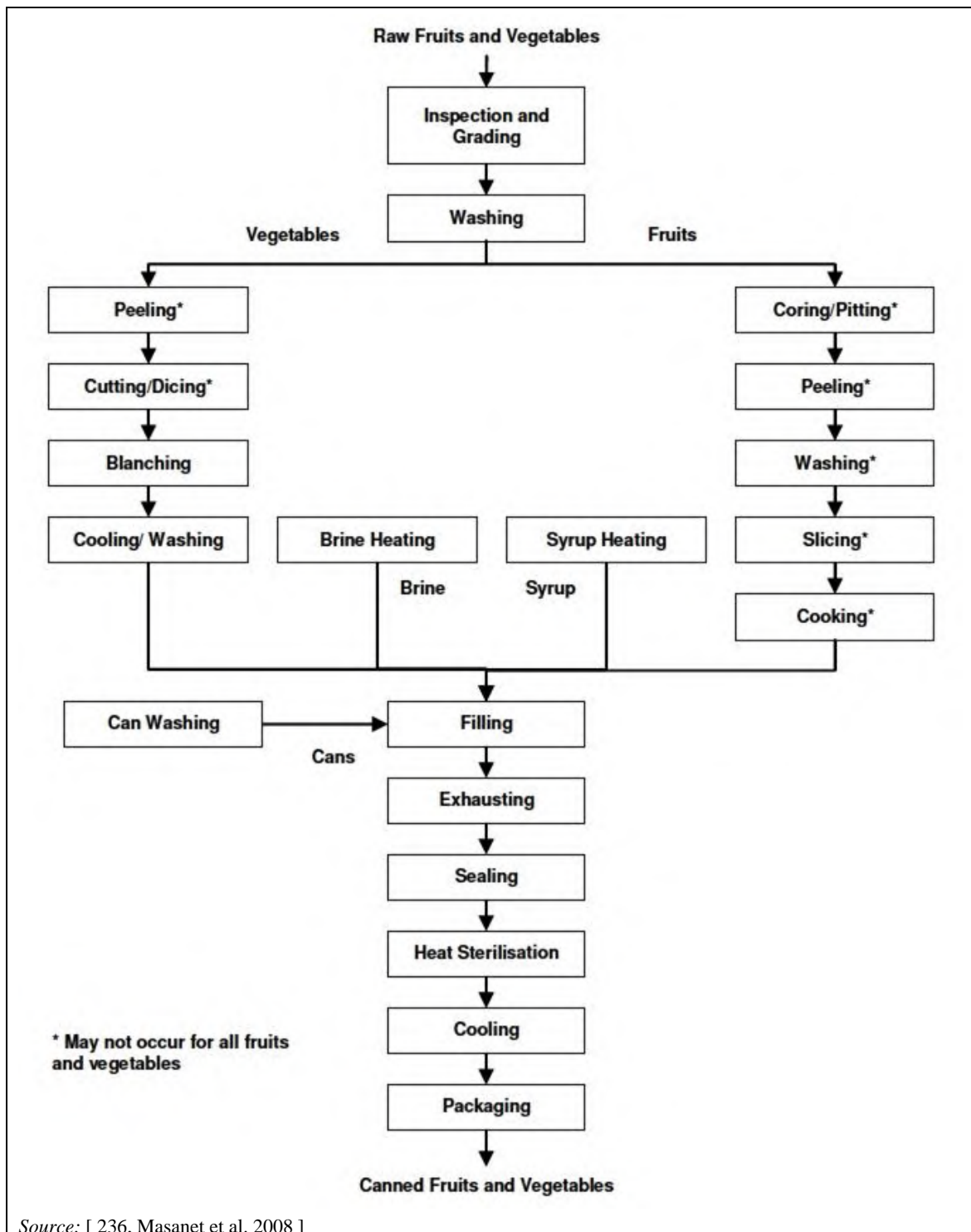

Figure 8.3: Flow diagram of fruit and vegetable canning

8.2.1.5 Wet caustic peeling

The material to be peeled is either placed in or passed through a dilute solution, e.g. 0.3–9 % NaOH at 60–90 °C. This softens the skin which can then be sprayed off by high-pressure water sprays. The caustic concentration and the temperature depend on the type of fruit or vegetable and the degree of peeling required. Although water is not used during the actual peeling operation, it is used for the continuous cleaning of rollers and blades, so contaminated waste water is produced. In some cases, caustic soda can be mixed with urea, for the same purpose and under similar process conditions [54, EUPPA 2018].

Reduced water and energy consumption, compared to steam peeling, is achieved.

Wet caustic peeling uses four times less water than steam peeling. Some products, e.g. tomatoes, require strong caustic solutions and the addition of wetting agents. In the case of gherkins, the concentration of the caustic is approximately 2 %, in the case of carrots approximately 10 % and in the case of pumpkins up to 20 %. Product loss is around 17 %.

Table 8.4 shows the effect of caustic peeling on water pollution in the production of half pears in syrup. This can be compared with the same operation using abrasion peeling followed by knife peeling. Table 8.5 shows energy carriers and consumption data for caustic peeling, prior to freezing vegetables.

Table 8.4: The effect of caustic peeling on water pollution in the production of half pears in syrup

	BOD (kg/t)	COD (kg/t)	SS (kg/t)
Caustic peeling	39.7	66.3	11.4
NB: Water consumption if the water is not reused for cooling cans after sterilisation: 29.6 m ³ /t. Water consumption if the water is reused for cooling cans after sterilisation: 6.2 m ³ /t. Source: [192, COM 2006]			

Table 8.5: Energy carriers and consumption for caustic peeling, prior to freezing vegetables

Energy carrier	Approximate consumption
Hot water (kWh/t frozen vegetables)	0
Steam (t/t frozen vegetables)	0.16
Steam pressure (bar)	7
Electricity (kWh/t frozen vegetables)	2
Source: [192, COM 2006]	

8.2.1.6 Dry caustic peeling

In dry caustic peeling, the material is dipped in a 10 % caustic solution heated to 80–120 °C, to soften the skin, which is then removed by rubber discs or rollers. This reduces water consumption and produces a concentrated caustic paste for disposal. Peeling is followed by washing to remove the peel and any residual caustic.

In the case of peeling peaches and apricots, the skin is very fine and soft and not as easily distinguishable from the fruit flesh as that of tomatoes, peppers and potatoes for example, so it clings to the flesh. The skin clings to the flesh of less ripe fruit more strongly than it clings to ripe fruit. Peaches and apricots are immersed in the caustic solution and the skin is decomposed. The residue is then removed by spraying the fruit with water. In practice, fruits of varying ripeness are peeled together and the process is prolonged to ensure that the least ripe fruit are peeled. In the case of peeling, for example, peaches and apricots for subsequent preservation either whole or in halves, the mechanical removal of the softened skin would cause unacceptable damage to the surface of the fruit.

Reduced water consumption, compared to steam peeling and wet caustic peeling, and reduced solid waste and waste water production, compared to wet caustic peeling, are achieved. Moreover, lower caustic consumption than wet caustic peeling and reduced energy consumption, compared to steam peeling, are achieved.

Dry caustic peeling methods can greatly reduce the volume and pollutant load of the waste water compared to steam peeling and wet caustic peeling. The peel can be collected as a pumpable slurry, which needs to be disposed of. It is reported that the peel contaminated with caustic is, at least in some cases, disposed of to the WWTP in small amounts, after buffering. Dry caustic peeling tends to have a lower caustic consumption than wet caustic peeling.

8.2.1.7 Enzymatic peeling

Enzymatic peeling can be applied to citrus fruits. Enzymes are applied under the skin of the fruit using needles, which are placed on rollers. The enzymes react with the white tissue between the peel and the flesh. After a certain reaction time, the peel becomes loose and can be manually removed. The result is a clean undamaged fruit without white tissue [87, Belgium-VITO 2015].

8.2.2 Blanching

Blanching is designed to expose the entire product to high temperatures for a short period of time. The primary function of this operation is to inactivate or retard bacterial and enzyme action, which could otherwise cause rapid degeneration of quality. Three other desirable effects of blanching include the expulsion of air and gases in the product, a reduction in the product volume, and the leaching out of reducing sugars in the case of potato processing.

Before blanching, the food can be preheated. Blanching may be accomplished by direct or indirect heating systems. This may depend on the product. Direct heating is normally done by immersion in hot water, at 80–100 °C, or by exposure to live steam. The operation is normally carried out in horizontal chambers. The residence time in the blancher can vary from approximately 1 to 5 minutes depending on the fruit or vegetable being blanched. For some products, direct contact with water is to be avoided so heat exchangers working with hot water or vapour are applied.

The most common blanching processes that are applied in the fruit and vegetable sector are described in more detail in the following subsections [1, CIAA 2002], [14, VITO et al. 2001], [15, Van Bael J. 1998], [51, Ullmann 2001], [138, Fellows P.J. 2000].

8.2.2.1 Steam blanching with air cooling

Steam blanching is a continuous process where the food is moved on one long perforated conveyor belt. During preheating, the food is sprinkled with water from above and sprayed by water from below. The preheating water is maintained at 60 °C using steam.

During the blanching step, the food is further heated by direct steam injection from below. To minimise water and energy consumption, the steam is recycled and the process takes place in sealed equipment, designed to minimise steam consumption.

Finally, the food is cooled with air using heavy-duty fans. The air is cooled further, to a lower temperature, by spraying water into the airflow. This water prevents the food from drying. If necessary, the food can be further cooled down with water in the last cooling compartment. Reusing this cooling water in the preheating section is not useful, as the water does not hold much energy. Air cooling is less energy-efficient than water cooling as the heat cannot be reused and the fans for blowing the air across the food have a high energy consumption.

The optimal temperature and time of blanching depend on the type of food and the size of the pieces being blanched. Typical blanching conditions are 65–95 °C, for one minute or more. Steam blanching produces waste water with high BOD levels.

The energy efficiency can depend on the method of retaining the steam pressure. Food can enter and leave the blancher through rotary valves and seals to reduce steam losses and increase energy efficiency, or steam can be reused by passing it through venturi valves. Using a combination of hydrostatic and venturi valves can improve the efficiency further.

8.2.2.2 Belt blanching with water cooling

Belt blanching with water cooling is a continuous process where the food is moved on one long perforated conveyor belt. The food is preheated with water sprinkled from above and sprayed from below, flowing countercurrently with the food. The temperature of the preheating water is maintained at 60 °C using steam. The cooled preheating water can be reused in other processes, e.g. washing and cutting and pre-rinsing of freezing tunnels for example.

In the blanching section, the food is also sprinkled with water from above and sprayed by water from below. For this step the water temperature is maintained, for example, at 80–95 °C by steam injection.

Finally, the food is cooled with water. Cooling is undertaken in a series of different compartments. In each compartment, water is sprayed over and under the food. Fresh cooling water, for example, at 2–15 °C enters the last compartment of the cooling section and is reused in the preceding compartments. The water from the first compartment of the cooling section, i.e. immediately after blanching, which is warm, is reused in the preheating section, leading to heat recovery and a reduction in water consumption. If the coldest water available is used for cooling, this also reduces the energy consumption, for both the cooling step after blanching and if the food is destined for low-temperature storage or processing, e.g. freezing. The optimal temperature and time of blanching depend on the kind and size of food. Hot water blanching produces waste water with high BOD levels.

If a belt blancher is combined with water cooling, 2–8 kWh_e/t of frozen product are consumed. Belt blanching with water cooling is the most energy-efficient blanching technique. The reason is that the heat released by the cooling of the food in the cooling zone is used to preheat the vegetables before blanching. Also, the water consumption is minimised by reusing it within the cooling compartments and for preheating.

Table 8.6 shows the energy carriers and consumption for the belt blancher with water cooling expressed in terms of the amount of frozen product, i.e. assuming the product will be frozen after blanching.

Table 8.6: Energy carriers and consumption for a belt blancher with water cooling

Energy carrier	Approximate consumption
Hot water (kWh/t frozen vegetables)	0*
Steam (t/t frozen vegetables)	0.09
Steam pressure (bar)	7
Electricity (kWh _e /t frozen vegetables)	2–9
* Hot water is 0 because water is heated by steam injection. Source: [192, COM 2006]	

8.2.2.3 Belt blanching with air cooling

This is a continuous process where the food is moved along on one long perforated conveyor belt. The food is preheated with water sprinkled from above and sprayed from below, flowing countercurrently with the food. The preheating water is maintained at 60 °C using steam. The cooled preheating water can be reused in other processes, e.g. washing and cutting processes and pre-rinsing of freezing tunnels for example.

In the blanching section, the food is sprinkled with water from above and sprayed by water from below. The water temperature is maintained, for example, at 80–95 °C by steam injection. The blanched food is cooled with air using heavy-duty fans. The air is cooled further, to a lower temperature, by spraying water into the airflow. This water prevents the food from drying. If necessary, the food can be further cooled down with water in the last cooling compartment. Reusing this cooling water in the preheating section is not useful, as the water does not hold much energy. This technique is less energy-efficient, because with air cooling the heat cannot be reused and the fans for blowing the air across the food have a high energy consumption.

The optimal temperature and time of blanching depend on the kind and size of food. Hot water blanching produces waste water with high BOD levels.

When a belt blancher is used combined with air cooling, 7–28 kWh_e/t of frozen product are consumed. Heavy-duty fans consume 60 kWh_e. Table 8.7 shows the energy carriers and consumption for the belt blancher with air cooling, expressed in terms of the amount of frozen product.

Table 8.7: Energy carriers and consumption for a belt blancher with air cooling

Energy carrier	Order of magnitude indicators
Hot water (kWh/t frozen vegetables)	0*
Steam (t/t frozen vegetables)	0.16
Steam pressure (bar)	7
Electricity (kWh _e /t frozen vegetables)	7–30
* Hot water is 0 because water is heated by steam injection. Source: [192, COM 2006]	

When processing preserves, cooling of the food to about 40 °C is sufficient, because it is subject to further processing involving heat which prevents the development of bacteriological problems. Preserves undergo heat treatment at a later stage, e.g. during sterilisation and pasteurisation. This means that less energy is used when applying this technique for preserves, compared to other uses of the fruit and vegetable sector which would need to be cooled further, e.g. prior to freezing.

8.2.2.4 Drum blancher with countercurrent water cooling

This is a batch process where the food enters the system via a trough and a rotating screw. The water for the blancher is heated by steam injection. The food leaves the system via a perforated paddle. Next, the product is cooled using water running countercurrently to the food. The heated cooling water can be reused in other processes, e.g. to simultaneously preheat the fresh food and transport it to the drum blancher.

The optimal temperature and time of blanching depend on the kind and size of the food. The drum blancher with countercurrent water cooling consumes 1–2.6 kWh_e/t of frozen product. The countercurrent drum cooler consumes 2–4 litres of water per kilogram of food.

Table 8.8 shows the energy carriers and consumption for drum blanching, expressed in terms of the amount of frozen product, assuming that the food will be frozen.

Table 8.8: Energy carriers and order of magnitude indicators of the drum blancher

Energy carrier	Approximate consumption
Hot water (kWh/t frozen vegetables)	0*
Steam (t/t frozen vegetables)	0.16
Steam pressure (bar)	7
Electricity (kWh/t frozen vegetables)	0.5–1.3
* Hot water is 0 because water is heated by steam injection. Source: [192, COM 2006]	

Table 8.9 shows the energy carriers and consumption for countercurrent drum water cooling, expressed in terms of the amount of frozen product, assuming that the food will be frozen.

Table 8.9: Energy carriers and consumption for countercurrent drum water cooling

Energy carrier	Approximate consumption
Hot water (kWh/t frozen vegetables)	0
Steam (t/t frozen vegetables)	0
Steam pressure (bar)	0
Electricity (kWh/t frozen vegetables)	0.5–1.3
Source: [192, COM 2006]	

8.2.3 Ready meals containing predominantly fruit and vegetables

Some fruit and vegetables are preserved. For this purpose, depending on the type of fruit and vegetables, different processes are used, and a variety of products are made, e.g. ready meals. In most installations, a variety of fruit and vegetable types are processed simultaneously and consecutively into different products. The majority of installations process products in bulk and are subject to seasonal variations, in line with crop rotation. However, some have product lines that are not affected by seasonal fluctuations. Further processing of frozen raw materials takes place throughout the year. Processing capacities are increasingly being expanded for such product processing.

8.2.4 Fruit juice

The bulk of the European fruit juice production is from citrus fruits, mostly oranges, from apple- and pear-type fruits and from vine fruits. Some stone fruit juices are manufactured but in much smaller quantities.

In a typical citrus juice process, the fruit is sorted, graded and washed to remove extraneous matter such as sticks and leaves, adhering dirt and insects. The fruit is then passed through oil extraction equipment where it is subjected to hundreds of small cuts of the skin to rupture the oil sacs and release the citrus oil, which is removed by washing. Oil extraction may be carried out after juice extraction. The fruit juice is mechanically extracted and screened to remove excess pulp, pieces of skin and seeds. The screened juice is preserved by a number of methods such as canning, aseptic processing, chemical inhibition, freezing, and membrane separation. It may be concentrated before packaging to reduce transport costs. The juice may be clarified before or after preservation.

A typical pome juice process includes similar processes but without an oil extraction step. The fresh fruits are delivered to the processing installation and unloaded, washed, sorted and then crushed after eventual coring or pitting, e.g. for peaches and apricots. The white fruits are heated to avoid enzymatic browning. The crushed fruits are then strained and refined to extract the juice. For apple juice, the juice is sometimes clarified with an enzymatic treatment and filtration.

Orange, apple and tomato juices are often concentrated, normally by evaporation or in some cases by RO or cryoconcentration. The juice is obtained either from fresh fruits or from reconstituted concentrates from citrus, pineapple and other tropical fruits. It can be packed directly, as is the case with juices, or mixed with sugar and water, as is the case with nectars. The juices are then de-aerated and hot-filled into bottles or cans.

Because of the low pH, filling with a HTST pasteurisation treatment is sufficient to stabilise the product when followed by bottle sterilisation in a steam tunnel. Aseptic packaging is carried out by pasteurising, cooling and filling, all in aseptic conditions. The filling is carried out in cardboard cartons or preformed cartons.

8.2.5 Heat-treated fruit

In typical canned fruit processes, the fruit is ideally used as soon as possible after delivery, although it often has to be stored for a time under chilled conditions, e.g. apples. The fruit is first washed, then sorted and possibly trimmed, then graded or cored before peeling. A variety of methods are used for peeling, including abrasive, caustic, steam or mechanical peeling. Peeled fruit may be blanched or transferred to tanks containing materials such as brine or ascorbic acid solutions to prevent browning. If necessary, the fruit may be sliced. Products such as orange segments are subjected to acid and caustic soaks to remove stringy fibres before canning. The fruit is filled into containers, e.g. cans or glass jars, in syrup or a natural juice. Before sealing, they can be gently heated to remove entrained gases, a process known as exhausting. Filling under vacuum conditions avoids the need for exhausting. The container is then sealed, heat-processed and cooled. For fruit, a pasteurising treatment with a temperature under 100 °C is sufficient.

8.2.6 Frozen fruit and vegetables

The freezing of fruit and vegetables is a major preservation method in its own right and it is widely used to preserve fruit and vegetables which are to be further processed, e.g. for the manufacture of jam. Fruit and vegetables intended for freezing are generally washed and inspected before being individually quick frozen, or packed in syrup or puréed before freezing. Typical fast freezing methods involve direct contact with a cooled solid, e.g. band or drum freezers, direct contact with cooled air or other gaseous mixtures, e.g. blast air, fluidised bed and spiral freezers, direct immersion in a cooled liquid, e.g. brine freezers, or cryogenic freezers. The process for deep-frozen fruit and vegetables is shown in Figure 8.4.

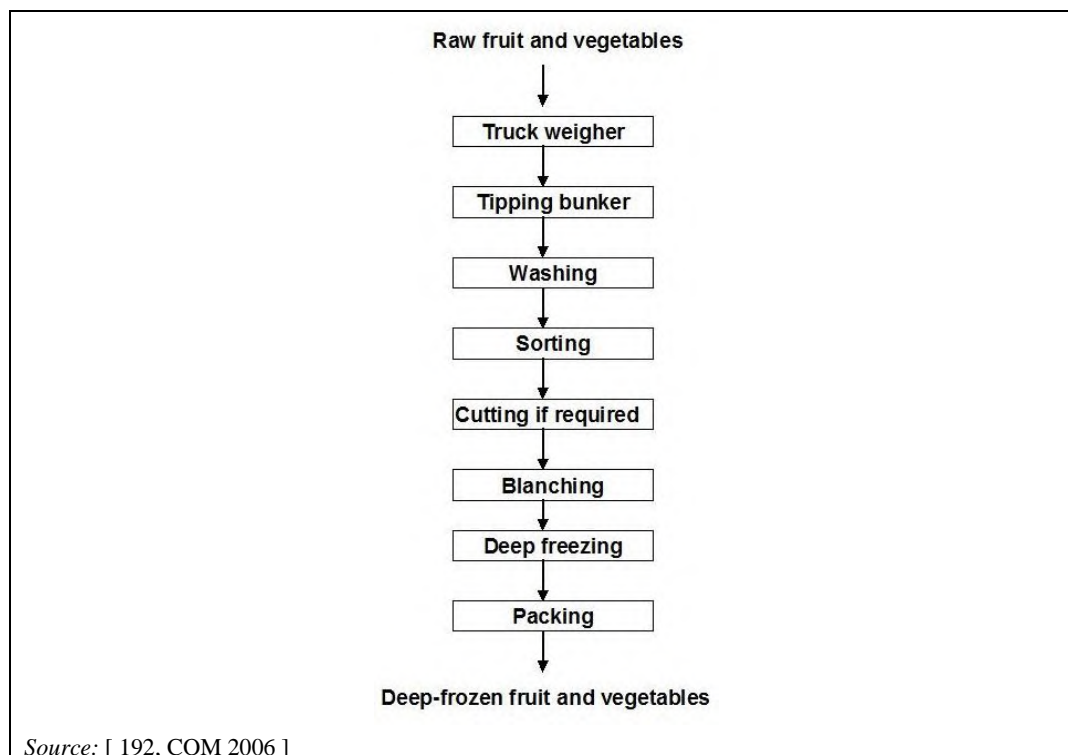

Figure 8.4: The process for deep-frozen fruit and vegetables

8.2.7 Fruit preserves

Preserving is the manufacture of jams, jellies, marmalades and mincemeat. It is essentially the combining of fruits and sugar with subsequent cooking. It produces a tasty product with a sufficiently high sugar content, low a_w value, and with a satisfactory shelf-life retention quality.

A pasteurising treatment is applied at 85 °C or above. The jams are made using pulp and fruit juice, e.g. citrus for marmalade, and clarified juice for jellies. The basic ingredients of a preserve are fruit; sweetening agents, typically sucrose and/or various sugar syrups; acids, typically citric or malic acid; buffers such as trisodium citrate; fats, in curds/mincemeat; citrus peel, for mincemeat and marmalade; gelling agents, usually pectin and anti-foaming agents—when using frozen or sulphited fruits. In a typical process, the fruit usually arrives pre-prepared either frozen or sulphited. The prepared fruit, pectin, sucrose, glucose syrup and other small ingredients are then blended together in a mixing vessel. The mix is boiled either at atmospheric pressure or under vacuum, using batch or continuous methods. After boiling, the jam is filled into containers which vary from individual portions to bulk tanks for bakery use.

8.2.8 Dried fruit

Dried fruit processing uses raw materials such as grapes, apricots, pears, bananas and plums. A basic process consists of sorting, grading, washing, drying and packing. Many fruits are sun-dried at source although some producers use mechanical methods, typically tunnels through which hot air is passed. Some fruits are sulphited before drying to preserve the fruit and soften the fruit tissue, leading to a faster loss of moisture during drying. In some cases, the fruit is sprayed or dipped after harvesting with a potassium carbonate solution which also contains dipping oil. The composition of the dipping oil varies between producers. For example, some producers use olive oil and others may use mixtures of ethyl esters of fatty acids and free oleic acid.

8.2.9 Tomatoes

In the EU, about 8 million tonnes of tomatoes were processed in 2000, of which 5 million tonnes were processed in Italy (5.18 million tonnes in 2016). Significant quantities are also processed in Spain, Portugal, Greece and France. The tomatoes are made into different forms for different kinds of products. The main product is 28–30 °Bx tomato paste obtained from the juice by concentration. Other products are whole, diced or crushed peeled tomatoes, tomato juices such as passata, and dried products such as powder and flakes. The basic processes for tomato manufacturing are shown in Figure 8.5.

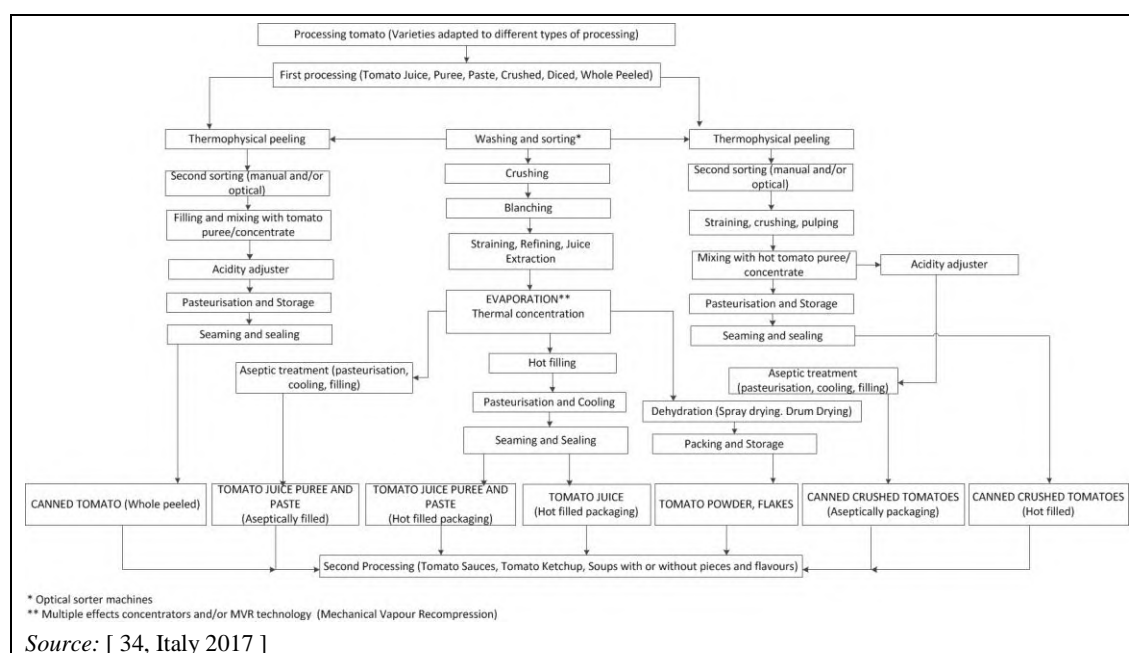

Figure 8.5: Main unitary operations of industrial tomato derivatives process

8.2.10 Potatoes

Two of the main potato-based products are crisps and fries. The manufacturing of both essentially consists of peeling the raw material, slicing it to an appropriate size and blanching, followed by frying to achieve the desired sensory properties. To prevent the discolourisation of fries, a substance called disodiumdiphosphate (E450i) is generally used in the potato processing sector. This is a very significant source of phosphorus in the waste water from potato processing installations. Sodium metasilphite (E223) may also be used to prevent potatoes from discolouring. Fries are mostly sold frozen and may be partially fried or fully fried. Crisps are increasingly sold in modified atmosphere packs.

Whether the product is potato fries, mashed potatoes or another potato product, there may be foam formation in the wash bath, which can lead to serious processing difficulties. Starch foam is very stable and difficult to remove. Mechanical methods of foam control have such limited effectiveness that the addition of foam-control agents may be the most practical solution [51, Ullmann 2001].

The objective of frying is to cook in edible oil at temperatures in the region of 175 °C. Vegetable oil, or a mixture of animal fat and vegetable oil, is normally used. The product is fed into the fryer on a slatted belt. The fryer is a horizontal chamber containing the oil. The product drops into the oil and, if it is coated in batter, this expands and brings the product to the surface of the oil. The slatted belt feeds the product under the main fryer belt, which takes the product through the fryer and controls the frying time. The take-out belt at the end of the fryer lifts the

product out of the oil, allows drainage and transfers the product to the inspection and packing belts. Fryers are equipped with a fume extraction fan to eliminate fume leakage. The frying temperature and time vary according to the product being processed. Temperatures range from 160 °C to 175 °C and residence times in the fryer are normally around 35 seconds but can be longer.

In several MS (e.g. Belgium, the Netherlands, France), it is typical that potato fries are produced in integrated plants (production of fries or purée products and potato starch production are carried out in the same plants).

8.2.10.1 Potato fries

Potatoes are delivered to the installation and are sorted to remove stones, pebbles and other extraneous matter. The raw material is washed, graded and peeled. A number of peeling methods are available, including mechanical, steam and caustic peeling. Large tubers are generally sorted for use in fries production. Potatoes are cut into the required size using independently driven multiple knives. Offcuts, slivers and broken pieces are removed before blanching. The fries are blanched using steam or water generally at around 60–85 °C. Multiple blanching stages may be used.

Excess moisture is removed from the fries both to preserve the life of the frying oil and to lower the moisture content of the fries. This also leads to a reduction in the required frying time. Conveyor dryers are used in large processing installations. The fries are fried, typically at around 160–175 °C; the time of frying varies for completely fried and partially fried products. Excess fat is removed from the fries before freezing. Some manufacturers recover the fat for reuse. Fluidised bed freezing may be used for freezing the finished product, although belt freezing reportedly provides a more energy-efficient option.

8.2.10.2 Potato crisps

Processing methods for the manufacture of crisps vary greatly, but generally take the form of washing, peeling, trimming and sorting, slicing, rinsing, partial drying, frying, salting, flavouring, cooling and packing. Potatoes are first washed with drum or flotation washers. Stones, sand, dirt and any extraneous matter are removed. Potatoes are elevated into washers and peeled by abrasion. Peeled potatoes are trimmed to remove eyes, bruises and decaying portions. Slicing is carried out using a series of blades mounted on a circular stationary plate and a rotating drum. Water is supplied to flush starch from the equipment. Sliced potatoes are washed, usually in drum washers, to remove surface starch and sugars.

Some manufacturers blanch crisps prior to frying using steam-jacketed water-filled tanks. Typical blanching conditions are 65–95 °C, for one minute or more. After washing, surface moisture is removed by various methods including compressed air and blower fans, vibrating mesh belts and heated air. Crisp frying may be batch or continuous. Temperatures are in the range of 160 °C to 190 °C and cooking times are typically between 1.5 and 3 minutes. When the crisps leave the fryer, they are agitated to remove excess oil and discharged to a belt running underneath a salter. Flavouring may be mixed with the salt or dusted/sprayed onto the crisps in rotating drums. Finally, the crisps are cooled and packed.

8.2.11 Vegetable juice

Significant quantities of juice are produced from vegetable sources such as carrot, celery, beetroot and cabbage. In general, fresh vegetables are first washed and sorted before being coarsely milled and then pressed to extract the juice. Most vegetable juices have low acidity, i.e. a $\text{pH} > 4.5$, and therefore they require a full sterilisation process for preservation. Vegetable juices are sometimes acidified with organic or mineral acids to reduce the pH , so that a milder heat treatment such as pasteurisation is then possible. Some low-acidity juices are blended with high-acidity juices such as tomato, rhubarb, citrus, pineapple or cabbage, so that they are acidic enough to only require pasteurisation. Some vegetables may be blanched prior to acidification and extraction. Root vegetables are usually peeled before maceration and extraction.

8.2.12 Heat-treated and frozen vegetables

Process conditions vary depending upon the vegetable type, but preliminary operations for both heat-treated and frozen vegetables are similar to those described in Section 8.2.5 for fruits. They usually involve washing, grading and screening to remove extraneous matter such as stones and dirt. After washing, the vegetables are peeled and may be trimmed. After peeling, the vegetables may be left whole or cut in a number of ways such as sliced or diced. Some vegetables are washed after slicing to remove the surface starch. Most vegetables require blanching. Steam or water blanching are the most common methods. The product is then cooled rapidly. After cooling, the product may be re-inspected and screened before being quick frozen or filled into cans or glass jars, usually with a hot brine, e.g. sugar, salt or acid, and then heat-processed. Vegetables generally undergo a full sterilisation process as the pH is too high to inhibit microbial action.

8.2.13 Pickling of vegetables

In a typical pickling process, raw vegetables are delivered, washed and then screened to remove extraneous matter such as stones. Depending upon the vegetable, the raw material might be steam-cooked and then cooled. The product is then peeled, typically using steam, and re-inspected before being cut to the required dimensions, e.g. sliced/diced/shredded, and transported to the filling line. The chopped vegetables are then filled into containers.

When the vegetables have undergone a fermentation process, their low pH limits the proliferation and germination of bacteria. A pasteurisation process is thus only needed if storage in ambient preservation conditions is required. When the product is packed with brine, sauce or any liquid filling (typically consisting of acetic acid, malt vinegar, spirit vinegar, distilled malt vinegar, liquid sugar and salt, depending upon the formulation), the pasteurisation of the food product and its packaging can be ensured by the packing medium, rather than using pasteurisation equipment (e.g. tunnel). In this case, the liquid medium is heated up to $80\text{--}95\text{ }^\circ\text{C}$ depending on the pH of the food product. It is then filled in the packaging, thus inactivating vegetative cells, yeasts and moulds. The packaging is immediately closed, then flipped so the hot liquid medium comes into contact with the lid to ensure its decontamination. The product is then flipped back, and cooled down either naturally or by cooling tunnels. Monitoring of liquid temperature and flipping time are critical parameters in relation to microbiological hazards of these products [54, EUPPA 2018].

8.2.14 Vegetable drying

Vegetable drying is used for raw materials such as potatoes, tomatoes, mushrooms and onions. The basic process is the same as in fruit processing, i.e. sorting, grading, washing, drying and packing. Many vegetables can be sun-dried at source. Mechanical methods can also be used.

8.3 Current consumption and emission levels

8.3.1 Energy consumption

Processes involving heating, cooling, drying, evaporation, sterilisation, pasteurisation and blanching consume significant energy. Almost every process step requires electricity. For steam production, natural gas boilers can be used. The frozen vegetable sector is a large consumer of electricity and natural gas. Deep freezing is the process which uses the most electricity.

Figure 8.6 shows data for specific energy consumption (MWh/tonne of products) from various fruit and vegetable installations. A distinction is also made between the installations according to the different raw materials they process.

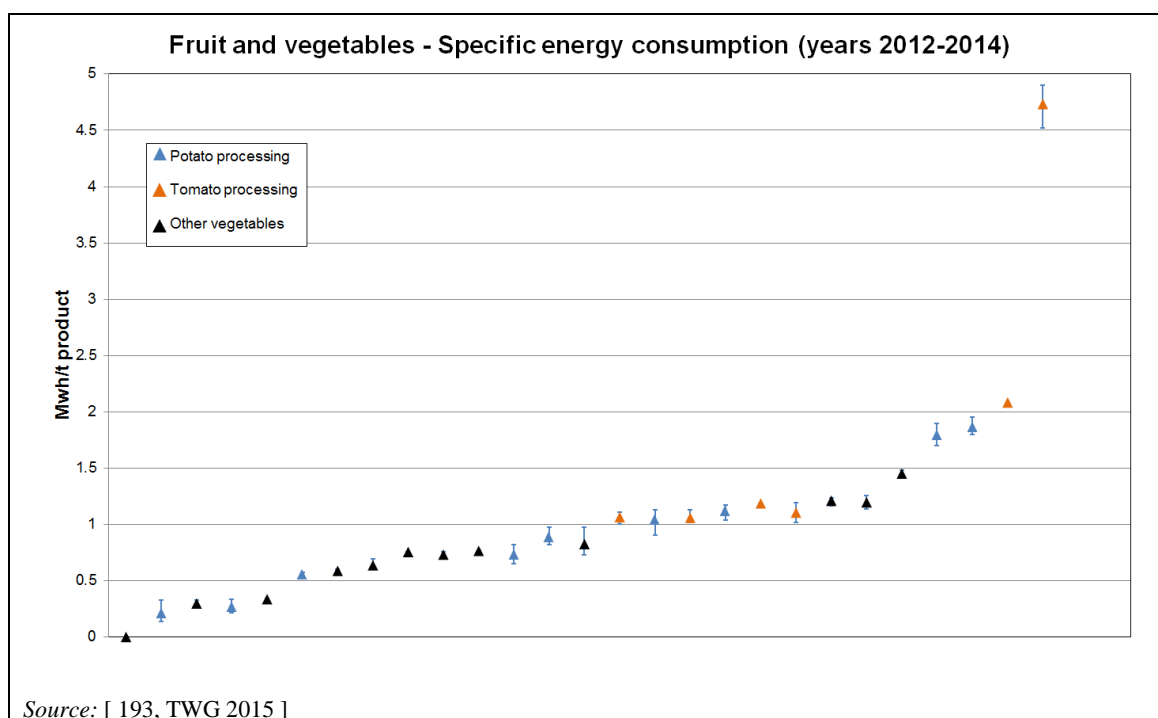

Figure 8.6: Specific energy consumption (MWh/tonne of products) in fruit and vegetable production

High energy consumption levels were reported for the production of tomato powder or concentrate, and the production of potato flakes and powder [193, TWG 2015]. Several installations in Spain producing tomato paste, powder and concentrate reported specific energy consumption levels in the range of 1.25–2.4 MWh/tonne of products [299, TWG 2018].

During deep freezing, cooling to a very low temperature, i.e. $-30\text{ }^{\circ}\text{C}$ to $-40\text{ }^{\circ}\text{C}$, is necessary. During this process, energy is consumed at a rate of 80–280 kWh_e/t of frozen vegetables. Other processes, e.g. washing, require less electrical energy, a maximum of 28 kWh_e/t of frozen product. Deep freezing carrots consumes ± 8 kWh_e/t and freezing salsify consumes ± 20 kWh_e/t and these require a lot of electrical energy for sorting. Washing spinach for deep freezing consumes ± 4 kWh_e/t and is electricity-intensive. The mechanical processing of frozen beans and salsify consumes ± 6 kWh_e/t and ± 9 kWh_e/t respectively, i.e. much more electricity compared with other vegetables.

The electricity consumption of the belt blancher with air cooling, which produces 7–30 kWh_e/t of frozen product, is significantly higher than that of the belt blancher with water cooling, which produces 2–9 kWh_e/t of frozen product, or the drum blancher with countercurrent water cooling, which produces 1–2.6 kWh_e/t of frozen product. Spinach requires the most electricity for intermediate processes such as packing or making of portions.

Steam is used for peeling and blanching. Steam peeling uses approximately five times more steam than caustic peeling. Belt blanching with water cooling consumes approximately half the energy of belt blanching with air cooling or drum blanching with countercurrent water cooling. For storage, electricity consumption is between 20 kWh_e and 65 kWh_e per m³ of storage space per year.

8.3.2 Water consumption

Water is used mainly during washing. It is also used during peeling and blanching.

Figure 8.7 shows data for specific water consumption (m³/tonne of products) from various fruit and vegetable installations. Water recycling is usually applied. Higher specific water consumption levels have been reported for tomato processing.

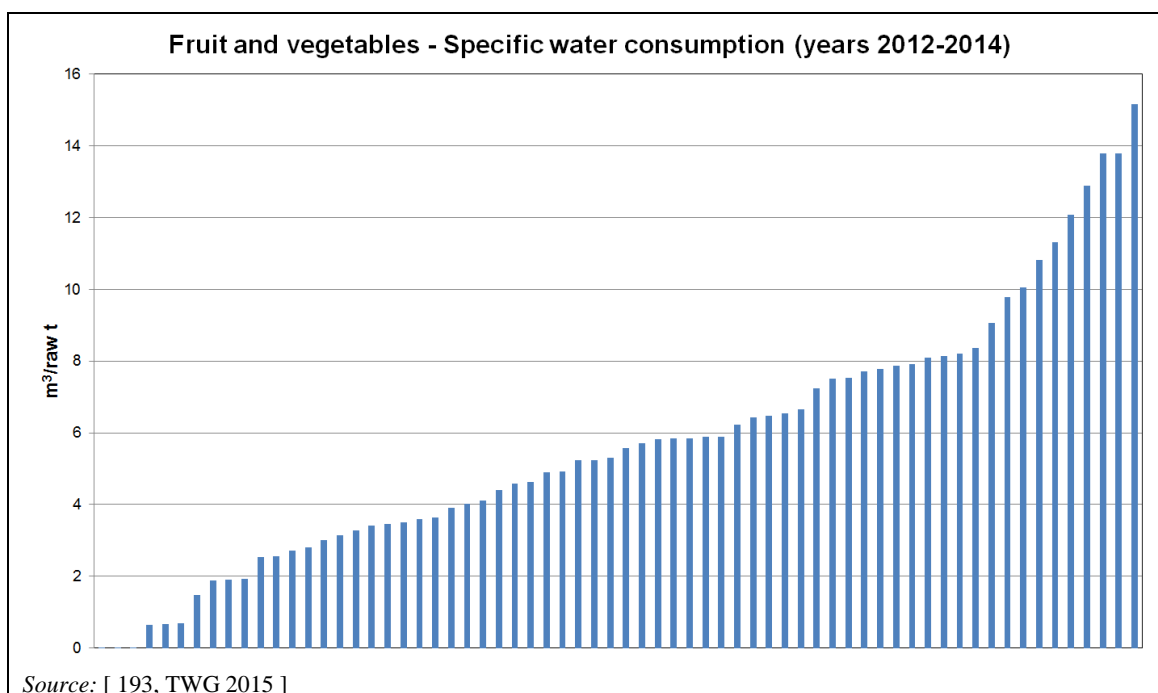

Figure 8.7: Specific water consumption (m³/tonne of products) in fruit and vegetable production

High waste water discharge levels were reported for the production of tomato powder, and the production of potato flakes and powder [193, TWG 2015].

Water consumption levels reported for some processes in the fruit and vegetable sector are shown in Table 8.10.

Table 8.10: Water consumption for some processes in the fruit and vegetable sector

Production of	Unit	Water consumption
Potatoes – fries	m ³ /tonne raw potatoes	1.25–4.3
Potatoes – purée and other potato products	m ³ /tonne raw potatoes	2.7–5
	m ³ /tonne produced	10
Fruit and vegetables - cans	m ³ /tonne raw product	1–16
	m ³ /tonne	8–9
Fruit - cans	m ³ /tonne produced	2.5–4.0
Vegetables - cans	m ³ /tonne produced	3.5–6.0
	m ³ /tonne raw product	10
Fruit and vegetables - frozen	m ³ /tonne raw product	13–43
	m ³ /tonne produced	5.0–8.5
	m ³ /tonne raw product	5
Fruit and vegetables - washing	m ³ /tonne raw product	3
Juice	m ³ /tonne produced	6.5

Source: [54, EUPPA 2018], [87, Belgium-VITO 2015]

8.3.3 Solid output

Large amounts of organic residues are produced. These are organic materials, including fruit and vegetables discarded during selection, and those from processes such as peeling or coring. These typically have a high nutritional value and can be used as animal feed or be led to anaerobic fermentation. Undesired materials discarded from the first processing steps include soil and extraneous plant material, spoiled food stocks, and some trimmings, peels, pits, seeds and pulp.

When caustic agents are used for peeling fruit and soft vegetables, a highly alkaline or salty solid waste is produced. High-moisture-content solid wastes can be generated by wet cleaning and reuse operations in which the dissolved solids or TSS are concentrated and separated from the waste water.

Possible reuse and disposal routes for the different residues produced are as follows:

- Non-nutritive fibre from apple pomace, dried citrus peel and lecithin from soybeans may be used for the production of foods such as fermented foods, drinks, oils and proteins, or for the development of biopolymers for elaboration of biodegradable packing and construction material. Pectin is extracted from apples. Citrus is extracted during juice production.
- Citrus wastes, grape lees, grapes and potato processing wastes may be used for biosynthesis of natural chemicals such as furfural, xylitol, alcohol, organic acids and polysaccharides, and pharmaceuticals such as hycogenin, antibiotics and vitamins. This option is growing as more opportunities are identified.
- Production of animal feed from sugar beet pulp, apple and tomato pomace and citrus pulp pellets, without or after treatment (physical, chemical, microbial, ensilage, production of microbial biomass). This use is limited by several factors, including shipping, putrefaction during storage and transport, and the presence of undesirable constituents such as alkalis or salt. Water content is the major contributor to shipping costs and to some extent to the putrefaction rates. Putrefaction reduces the shelf life and value of the solid wastes and limits their use as animal feed.
- Peach and olive pits, rice hulls and straw may be burnt directly, or converted to produce biogas or alcohol. Incineration is a viable option for solid wastes with a relatively low (< 10 %) water content. Catalytic gasification or pyrolysis may also be applied.
- Composting and landspreading of organic waste is limited because of odour and possible soil contamination by leaching of organics and salts.

Within the unit operations used in the fruit and vegetable sector, peeling is one of the major solid output and waste water producers.

Steam peeling is generally used for large quantities of potatoes, carrots and other tubers. Preprocessing includes washing and the separation of mud and stones. This solid waste has no value for bioconversion. The waste produced in peeling has solids, mainly peel, which are separated by sedimentation from the aqueous phase, dried and may be composted. They may be further treated to recover minerals, fibre and phenolics. The aqueous phase goes for waste water treatment together with waste water from other processes. Its pollutant load, before discharge to the MWWTP, expressed in COD is about 4 000 mg/l. Soluble vitamins, starch, fibre and tissue fluid may be recovered from this waste water.

Mechanical peeling is used for small quantities of potatoes, carrots, apples, pears, etc. or when vegetables are used for catering or in institutional kitchens. The peeling is often performed outside the main processor. There are numerous peeling companies with varying capacities and equipment. The unit operations are basically the same as in steam peeling. The processing starts with the separation of mud and stones similar to the step for the steam peeling process.

The peeling consists of three consecutive steps: mechanical pre-peeling, using for example carborundum; knife peeling; and then washing. Waste water is produced in all three steps. After sedimentation, the aqueous phase goes for waste water treatment. Its pollutant load expressed in COD is about 5 000 mg/l. The separated solid phase is normally composted. Vitamins, starch, fibre and minerals may be recovered.

Knife peeling produces a similar output to steam peeling and it can be used similarly, either directly as animal feed or for recovery of its components. About 60 % of the total organic solid waste produced comes from pre-peeling, by abrasion peeling, and the rest is from knife peeling. After cutting, defective pieces, which are too dark or too small for example, are separated and used as animal feed. However, especially in carrot processing, several valuable substances such as vitamin C, fibre, phenolic compounds and carotenoids can be recovered from this by-product. The next step is rinsing and, in the case of potato processing, this is usually combined with the addition of disodiumdiphosphate (E450i) to prevent colourisation (in the event that the potatoes are blanched) or sulphites (in the event that they are not blanched).

8.3.4 Emissions to water

Waste water characteristics are affected by various factors. These include the raw material being processed, seasonal and source variations, unit operations, production patterns and operator practice.

Figure 8.8 shows reported data on specific waste water discharges (m³/tonne of products) from fruit and vegetable installations and all types of discharges. A distinction is also made between the installations according to the different raw materials they process. Higher discharged waste water volumes have commonly been reported for tomato processing.

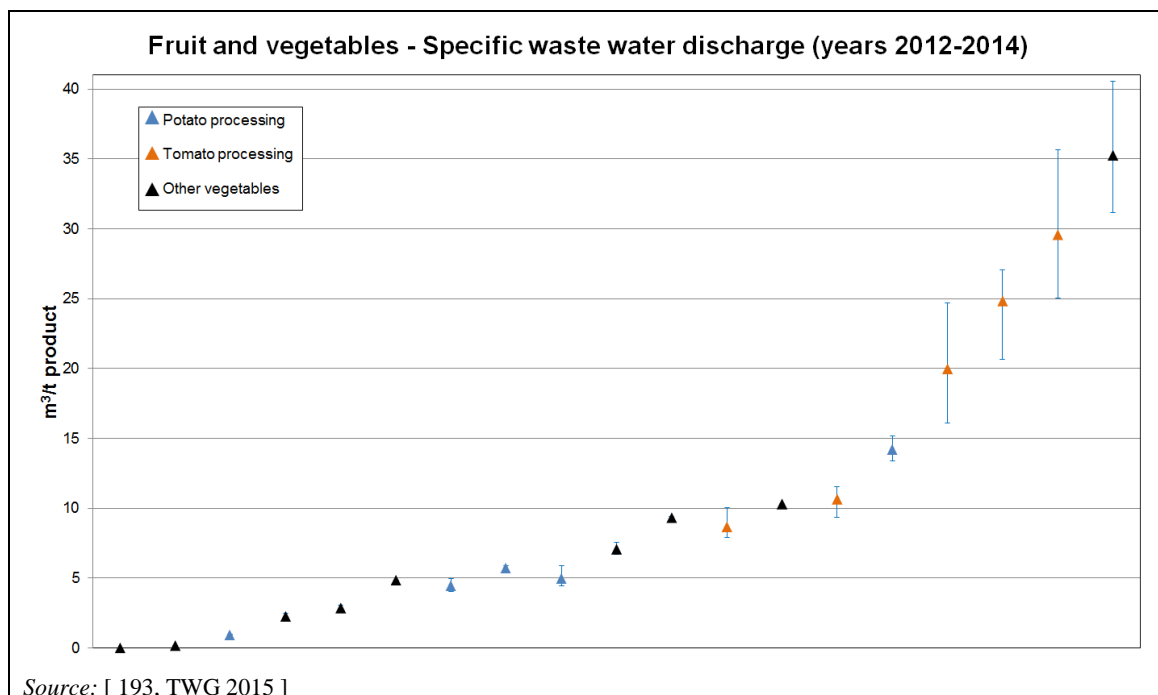

Figure 8.8: Specific waste water discharge (m^3/tonne of products) in fruit and vegetable production for all types of discharges

The leaching of sugars, starches and other soluble organic compounds from the raw fruit or vegetables into the blanching water results in high BOD, TSS and dissolved solids emission levels. As blanching water is normally reused/recycled, the volume of waste water from blanching is normally relatively small. However, this tends to concentrate pollutants in the waste water.

Reported emission levels in surface waters arising from the processing of various fruit and vegetables in Belgium are shown in Table 8.11 and Table 8.12.

Table 8.11: Emissions to water from potato processing

Parameter (mg/l)	Potato processors – frozen			Wholesalers and processors of fresh potato products		
	Mean	Median	Maximum	Mean	Median	Maximum
BOD	4	3	16	6	5	19
COD	40	33	290	80	54	350
N total	14	6	210	11	7	83
P total	5.9	1.6	70	5	2	48
Suspended solids	12	6	60	15	15	55

Source: [87, Belgium-VITO 2015]

Table 8.12: Emissions to water from fruit and vegetable processing

Parameter (mg/l)	Frozen products			Prepared fruit and vegetables		
	Mean	Median	Maximum	Mean	Median	Maximum
BOD	5	4	22	3	3	9
COD	61	50	290	33	29	103
N total	8	5	72	11	4	72
P total	3	2	28	2.3	1.4	11.5
Suspended solids	14	10	56	10	7	42

Source: [87, Belgium-VITO 2015]

Up to this point in this section, general data on water pollution from fruit and vegetable processing have been reported. In the following paragraphs, there is a breakdown of all unit operations that generate waste water. A reported typical process showing the waste water which arises from the major unit operations is shown in Figure 8.9.

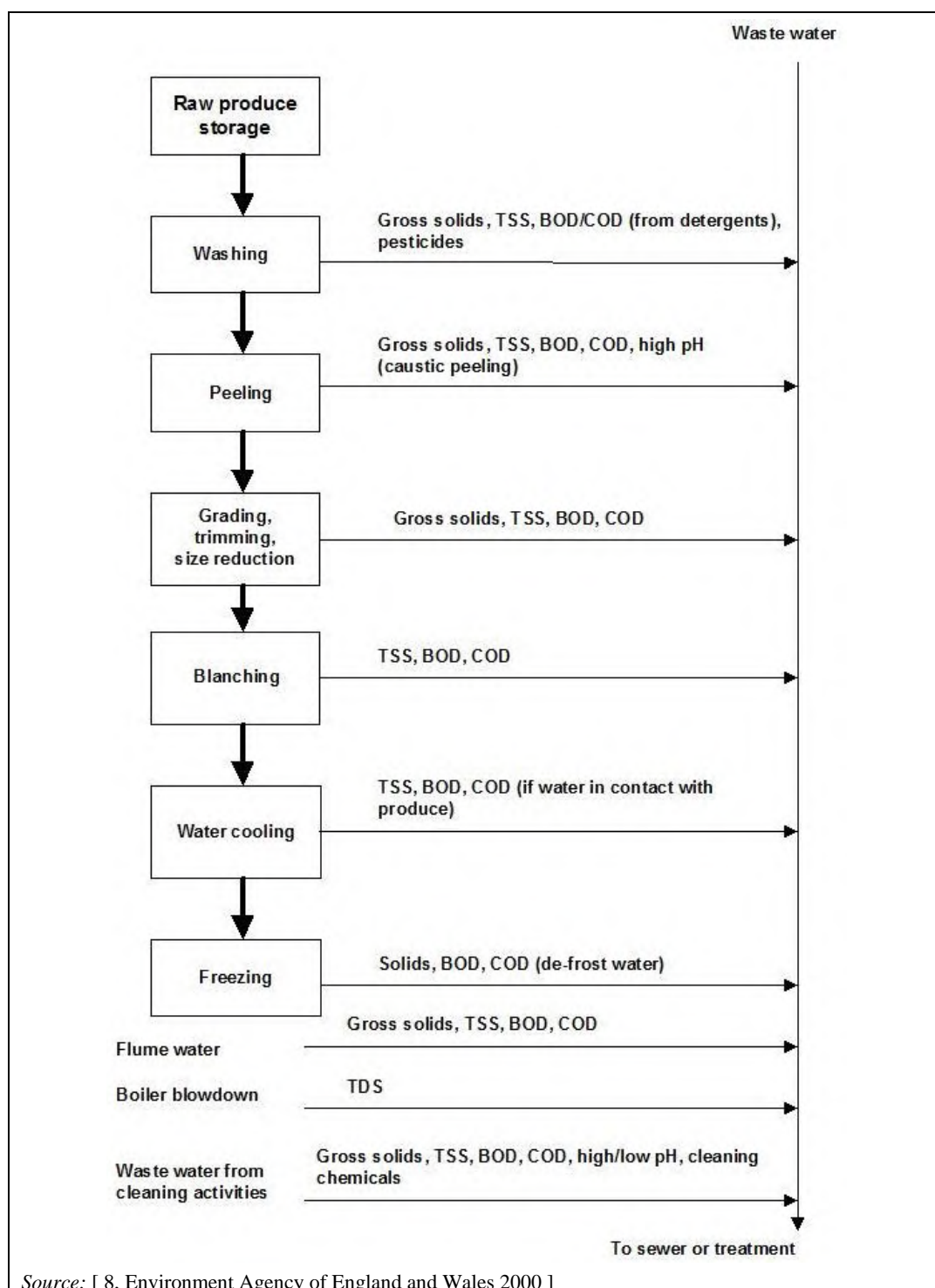

Figure 8.9: Waste water produced in fruit and vegetable processing

The incoming produce is washed in water to remove residual soil, stones and other debris. Large volumes of chlorinated water are required, especially for root vegetables which carry a lot of earth, and leafy vegetables which have a large surface area. Mechanical or air flotation techniques are used to aid soil removal and reduce the quantity of water used. Some

recirculation or reuse of water from other operations is common. Waste water from prewashing mainly contains field debris and soil particles with small fragments of the fruit or vegetables.

Most processes involve some type of grading, trimming and size reduction. Sometimes density graders containing brines of different strengths are used. Discharge of significant quantities of brine can adversely affect any biological WWTP. Washing of the produce after these operations creates waste water containing soluble starch, sugars and acids. The use of water fluming to convey both the product and waste material causes additional leaching of these substances. Waste water from citrus fruit processing also contains pectic substances that can interfere with the sedimentation of TSS.

All lines, equipment and process areas that are not in designated dry areas require wet cleaning, which generates waste water contaminated with raw material, product and cleaning chemicals. There are generally fewer requirements for aggressive chemicals in this sector than in others, unless oil or fat is used in processing.

More information on emissions to water can be found in Section 2.2.3.

8.3.5 Data for some fruit and vegetable products

8.3.5.1 Fresh-pack fruit and vegetables

Fresh-pack fruit and vegetables require minimal processing. Water consumption is mainly for produce washing, transport flumes and line cleaning. Processing installations are often close to growing areas, creating opportunities for the use of waste water in irrigation. Some fresh-pack vegetables require peeling.

8.3.5.2 Preserved fruit and vegetables

Fruit and vegetables that are to be preserved undergo further processing. The most common types are discussed below.

Many vegetables and some fruits require peeling, which can be a major source of BOD and TSS and represent a substantial proportion of the total waste water volume. Peeling is usually followed by washing.

Conventional steam peeling uses large quantities of water and produces waste water with high levels of product residue. At potato processing installations, the peelings can contribute up to 80 % of the total BOD. In fruit processing, peeling waste water can account for as much as 10 % of the total waste water flow and 60 % of the BOD. Water cooling in steam peeling increases water consumption.

Caustic peeling causes higher solubilisation of material and consequently a higher COD, BOD and TSS load than mechanical peeling, which is a combination of knife and abrasion peeling. Furthermore, the use of caustic in peeling may lead to pH fluctuations in the waste water. Dry caustic peeling tends to have a lower caustic consumption than wet methods and can greatly reduce the volume and pollutant load of the waste water from this operation and allows for the collection of peel as a pumpable slurry.

Blanching is used in most vegetables destined for canning, freezing or drying. Typically, it is carried out using hot water or steam. If the produce is to be frozen, blanching is followed by water or air cooling.

Both water and steam blanching produce waste water high in BOD; in some cases, over half of the total BOD load. The volume of waste water is less with steam blanching than with water

blanching. The quantity of waste water from steam blanching can be reduced by steam recycling, effective steam seals and equipment designs that minimise steam consumption. Waste water can be completely eliminated by microwave blanching, which is used in Europe and Japan.

For fruit and vegetable products which can be microbiologically sterilised at temperatures no higher than 100 °C, sterilisation, which, in this case, is generally named pasteurisation, can be carried out in installations using hot water or steam at atmospheric pressure. The most traditionally used low-temperature process is the open bath. These are metallic cylindrical or parallel piped baths, containing water heated by direct steam injection with a nozzle placed on the bottom. These baths are not generally equipped with automatic thermostats. The operating temperature is the boiling point of water at atmospheric pressure with a continuous flow of excess steam. The packs to be sterilised are loaded into large baskets; the baskets, by means of pulleys, are immersed in the baths and treated by boiling water for the required time. Cooling does not generally take place in the sterilising bath itself, which is thus ready to receive a new load, but in another bath containing cold running water.

For products packaged in glass containers, linear tunnels are used, including the phases of feeding, preheating, heating, precooling, cooling and drying. Heating is by means of saturated dry steam or hot water coming down on the packs from the top from a series of nozzles or by simple percolation from a perforated ceiling. The water is then recovered in recycling baths equipped with direct or indirect steam heating. Cooling is also carried out by sprinkling with water. Precooling water is partially recycled, thus keeping it at around 60 °C. The drying step is indispensable for the prevention of marks on the cap and above all to enable labelling and secondary online packaging. It is carried out by means of hot or cold air blowers. To sterilise low-acidity products, which require temperatures greater than 100 °C, various means of heating can be used, although autoclaves are predominantly used. All high-temperature sterilisers operate at pressures higher than atmospheric.

Single-phase acid products or products with small pieces, such as fruit juices, vegetable juices and purées, tomato purées, jams, marmalades and jellies, can be hot-filled. Heat sterilisation may be carried out before packaging because of the low pH and/or a_w of these products. The hot product itself sterilises the metal or glass container, so that only the caps and necks of bottles, and lids of small containers, need to be sterilised separately. Filling and hermetic closure of the container need to be carried out before the product cools down. The filling temperatures are kept between 85 °C and 92 °C. In all cases, the subsequent cooling is undertaken with sterilised chlorinated water.

Finally, aseptic packaging is undertaken. It is a combination of sterilising plants for the product and for the containers of various types, with an isolated system of filling and sealing. The aseptic packaging of liquid products involves the following sequence of operations: heating at prefixed temperatures; transfer to a holding section; cooling at a temperature of around 35 °C; filling of the pre-sterilised pack, opening and kept in conditions of perfect asepsis; and closure of the pack. The type of heat exchanger is selected according to the rheological properties of the fluid. They can be tubular of the circular crown type or scraped-film exchangers for products with high Re values and tube-in-tube-in-tube exchangers or plate exchangers for products with low Re values [66, Italy 2002].

Pickling is also an important operation for the preservation of fruit and vegetables. Pickling can be carried out by adding organic acids until the pH is below 4.3. In the process of making sauerkraut, salt is added (brining/curing) to promote the growth of lactic acid bacteria, for taste reasons and for conservation. The following process phases produce brine: fresh brine after slashing and salting (100–150 kg/t of white cabbage) and sour brine in the course of lactic fermentation (150–180 kg/t of white cabbage). The blanching process is carried out in sour brine, which produces blanching brine. Table 8.13 shows the waste water values of brine during the production of cabbage.

Table 8.13: Waste water values of brine during the production of sauerkraut

Brine	pH	Concentration in waste water		
		BOD ₅ (mg/l)	COD (mg/l)	Chloride (mg/l)
Fresh brine	6.0–6.2	10 000–30 000	15 000–40 000	12 000–15 000
Fermentation brine	3.8–4.2	17 000–50 000	25 000–75 000	2 500–20 000
Blanching brine	3.8–4.0	40 000–55 000	65 000–85 000	–
<i>Source:</i> [192, COM 2006]				

8.3.5.3 Frozen vegetables

Material handling and storage

In manufacturing frozen vegetables, transportation and storage operations require energy approximately as follows [15, Van Bael J. 1998]:

- The transportation of frozen vegetables requires 2–14 kWh/t of frozen vegetables. For most production lines, the electrical rating of the belts is between 5 kWh and 30 kWh.
- The storage of vegetables needs 20–65 kWh of electricity per m³ of storage per year.

Sorting/screening, grading, dehulling, destemming/destalking and trimming

The sorting operation has an electrical energy consumption of approximately 0–20 kWh_e/t of frozen vegetables [15, Van Bael J. 1998]. Table 8.14 shows the approximate electricity consumption during the sorting of vegetables.

Table 8.14: Electricity consumption during the sorting of vegetables

Product	Electricity consumption (kWh _e /t frozen vegetables)
Spinach	0
Cauliflowers	1
Peas	4
Sprouts	4
Beans	5
Carrots	8
<i>Source:</i> [15, Van Bael J. 1998]	

Peeling

In frozen vegetable processing, salsify and carrots are peeled before being mechanically processed. Caustic peeling and steam peeling are two methods used. Caustic peeling needs less energy, both in terms of electricity consumption and steam consumption, than steam peeling, but creates a higher load for the WWTP. Table 8.15 shows the approximate energy carriers and consumption for the caustic peeling of vegetables and Table 8.16 shows the approximate energy carriers and consumption for the steam peeling of vegetables.

Table 8.15: Energy carriers and consumption for the caustic peeling of vegetables

Energy carrier	Approximate consumption
Hot water (kWh/t frozen vegetables)	0
Steam (t/t frozen vegetables)	0.16
Steam pressure (bar)	7
Electricity (kWh/t frozen vegetables)	2
<i>Source:</i> [15, Van Bael J. 1998]	

Table 8.16: Energy carriers and consumption for the steam peeling of vegetables

Energy carrier	Approximate consumption
Hot water (kWh/t frozen vegetables)	0
Steam (t/t frozen vegetables)	0.9
Steam pressure (bar)	4–15
Electricity (kWh/t frozen vegetables)	3.5
<i>Source: [15, Van Bael J, 1998]</i>	

Washing

Washing, as used in the production of frozen vegetables, needs approximately 0–5 kWh_e/t of frozen vegetables. Certain vegetables, e.g. sprouts and cauliflowers, do not require any washing and thus do not consume energy.

Cutting, slicing, chopping, mincing, pulping and pressing

Some vegetables are cut before deep freezing. The electrical energy consumption is approximately up to 9 kWh/t of frozen vegetables. Carrots, salsify and beans require a reasonable amount of electrical energy for mechanical processing. Other vegetables do not require any electricity at all.

Blanching

Drum and belt blanchers are used in manufacturing deep-frozen vegetables. Energy consumption depends not only on the type of blanching device, but also the type of subsequent cooling step. Furthermore, the electricity consumption for the production of ice-water is included in the electricity consumption shown for deep freezing. For example, in terms of energy consumption, the belt blancher with water cooling has the lowest total consumption. The heat released by the cooling of the product in the cooling zone is used to preheat the vegetables. In this way, less steam is necessary for blanching.

With regard to electricity consumption, the drum blancher for countercurrent water cooling has the lowest consumption. The water consumption for such an installation is relatively high. The use of heavy-duty fans (60 kW_e) in the belt blancher with air cooling make the electricity consumption high for this type of operation.

8.3.5.4 Juices

Energy is consumed when the juice is concentrated by evaporation and during pasteurisation. Waste water is produced from the condensate during evaporation and during start-up, product changeover and cleaning of pasteurisers. Solid wastes are produced during the pressing of fruit and vegetables. For example, 2 % of tomatoes and 30 % of citrus fruits may be lost as solid wastes during pressing [96, Italy 2003].

8.3.5.5 Other products

Jams, jellies and preserves are based on the production of fruit gels, which come from extracted juices, purées or the whole fruit respectively. Fruit gels are composed of pectin, acid, sugar and water. The use of sugar and additional cooking tends to increase the BOD of waste water compared with most other fruit processing. The presence of natural or added pectin in the waste water may have an adverse effect on solids settling.

8.4 Techniques to consider in the determination of BAT

8.4.1 Techniques to increase energy efficiency

8.4.1.1 Cooling fruit and vegetables before freezing

Description

The temperature of the fruit and vegetables is lowered to around 4 °C before they enter the freezing tunnel by bringing them into direct or indirect contact with cold water or cooling air. Water can be removed from the food and then collected for reuse in the cooling process.

Technical description

The temperature of the fruit and vegetables can be lowered by bringing them into contact with sufficiently cold water for a sufficient time. This is generally the cooling step after blanching. If the ambient temperature of the water is above 4 °C, an ice-water trough can be used to cool the fruit and/or vegetables to 4 °C. Additionally, the circulating water in the ice-water trough can be continually cooled by fitting an additional water cooler in the ice-water trough (see Figure 8.10) or by placing an evaporator plate under the ice-water trough (see Figure 8.11). This evaporator plate is connected to the freezer system in a similar way as the heat exchanger for ice-water production. If the water is carried into the freezing tunnel it becomes frozen and adds an additional energy burden. This can be prevented by passing the food over a vibrating mesh or perforated belt which enables the water to be removed from the food and then collected for reuse in the cooling process.

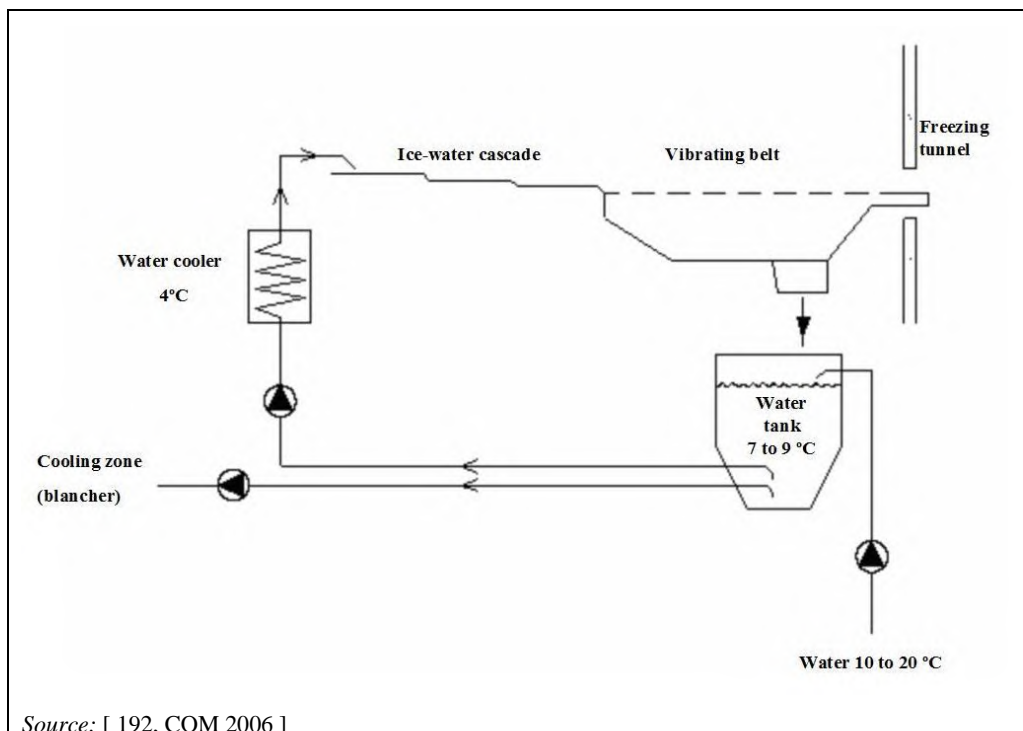

Figure 8.10: Installation of a water cooler in the ice-water trough

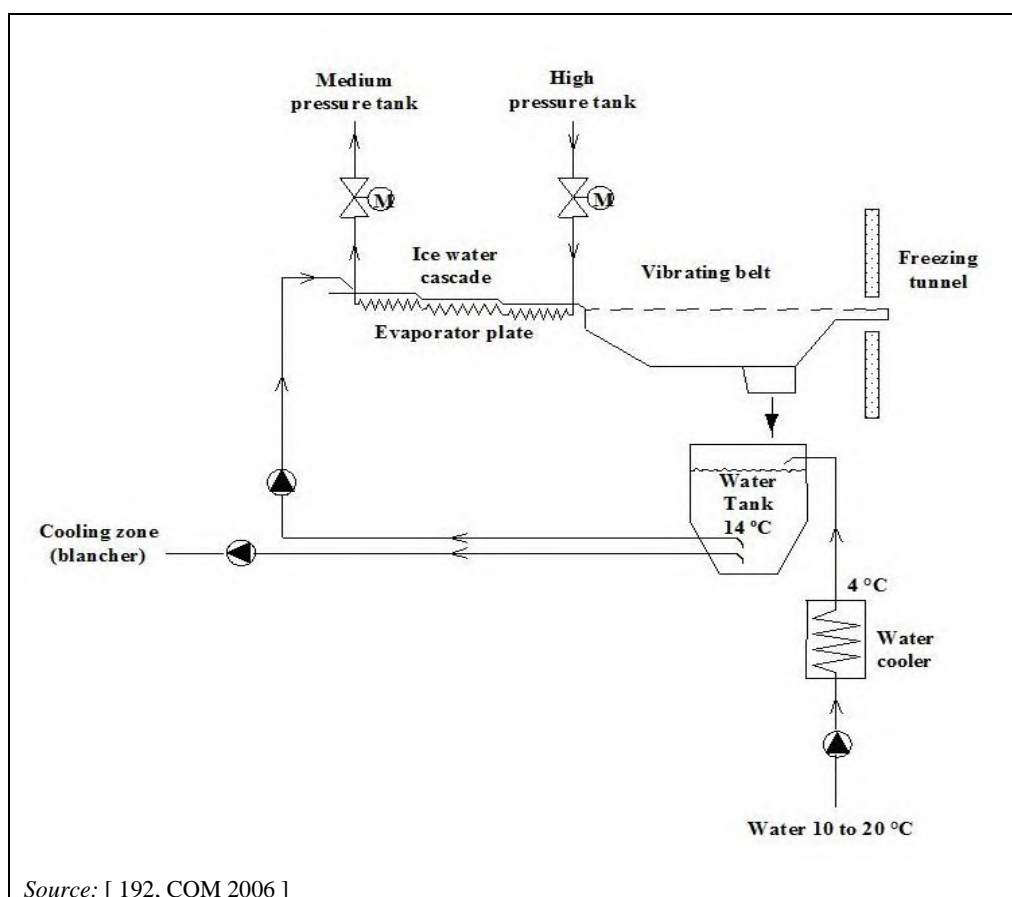

Figure 8.11: Installation of an evaporator plate under the ice-water trough

Achieved environmental benefits

Reduced energy consumption in the freezing process.

Environmental performance and operational data

It is reported that a reduction of the product temperature by 10 °C results in:

- a reduction of the compressor load for cooling at -30 °C to -40 °C, which reduces electricity consumption by 5–7 kWh/t;
- an increase in the compressor load for cooling at 0 °C, which reduces electricity consumption by 1.5–2 kWh/t;
- a total reduction of the electrical load by 3–5.5 kWh/t.

It is also reported that, when a freezing tunnel is operating at a product flow rate of 10 t/h, then the electrical load will fall by 30–55 kW if the fruit or vegetable temperature is reduced from 30 °C to 20 °C before entering the freezing tunnel. Furthermore, the heat transfer when the cooling is carried out with water is an order of magnitude higher than when the cooling is carried out with air. In addition, fruit and vegetables are best transported as cold and dry as possible in the freezing tunnel, in order to reduce the freezing load, and this is facilitated by draining the fruit or vegetables after immersion in the cold water.

Cross-media effects

Energy consumption in the cooling process before freezing.

Technical considerations relevant to applicability

Applied in the deep freezing of fruit and vegetables.

Economics

No information provided.

Driving force for implementation

Reduced energy costs.

Example plants

No information provided.

Reference literature

[14, VITO et al. 2001], [15, Van Bael J. 1998], [192, COM 2006]

8.4.2 Techniques to reduce water consumption

8.4.2.1 Dry cleaning

This technique is described in Section 2.3.3.2.1.

Technical description

After being harvested and transferred to plants, raw fruit and vegetables usually go through the first cleaning steps without water use. Several techniques can be used depending on the plant. The soil can be removed by drums circled by a metallic grid: the friction of this grid on the fruit/vegetable scratches out foreign bodies. The stones, stems and leaves are removed by density tables or blowing fans.

Technical considerations relevant to applicability

Applicable to all fruit and vegetable processing installations.

Reference literature

[54, EUPPA 2018]

8.4.2.2 Water recycling

See also Section 2.3.3.1.1.

Description

Recycling or reuse of water streams (preceded or not by water treatment), e.g. for cleaning, washing, cooling or for the process itself. The degree to which the water can be recycled or reused is limited by hygiene and food security requirements and the water demand of the process.

Technical description

The segregation of rainwater, wash water, e.g. water that arises from washing raw materials and from cleaning operations, and process water, e.g. water that arises from peeling, sorting and canning, has been reported. Furthermore, water that has only been used for washing incoming products and has low levels of BOD can be just screened rather than undergoing full treatment. The same applies to freezer defrost water.

For example, in belt blanching with water cooling the water from the first compartment of the cooling section, i.e. immediately after blanching, which is warm, can be reused in the preheating section before blanching. In this example, heat is recovered and less water is used due to the recirculation. It is also reported that, for some fruit and vegetables, blanching water can be used for preliminary cleaning of freezing tunnels.

Water used for blanching and water used for cooling after blanching can be used for washing raw materials, without treatment. Water used for boiling fruit and vegetables can also be used for washing raw materials, without treatment.

Water from cooling cans and jars in fruit and vegetable preservation can be reused as cooling water after sterilisation of the cans and jars, for washing raw materials, for washing peeled fruit and vegetables, to heat cold water for use in blanching or as cleaning water.

Water from sterilisation processes can be used to prewash raw materials. If this water is heated it may affect the shelf life of the food, by encouraging bacterial growth. Reuse of heated water for washing may depend on whether the fruit and vegetables are subjected to heat treatment later.

After biological waste water treatment and chlorination, water can be reused for cleaning floors. After biological treatment, RO and UV disinfection water can be used for uses which require drinking water standards.

Achieved environmental benefits

Reduced water consumption and, where heated water is reused, reduced energy consumption.

Environmental performance and operational data

A total of 1 200 m³/day of vegetable washing waste water can be produced by a UK vegetable processing installation with up to 815 m³/day being pumped forward to an advanced MBR. Following RO and UV disinfection stages, up to 650 m³/day can be returned to the factory as salad washing and process water. The influent COD_{total} that is received at the balancing tank is up to 1 440 kg/day, depending on the production rate [61, UK 2002].

The intensive aerobic environment created in the bioreactors, each with a design MLSS level of 15 000 mg/l, combined with the high relative sludge age means that high-quality final waste water can be achieved with a much smaller footprint. The bioreactor volume is reduced to as low as 20 % of the size of a conventional treatment.

About half of the waste water after full treatment reaches drinking water quality and can be reused within the installation. The original COD of about 1 500 mg/l was reduced to almost zero. The ultrafiltration biomass separation system also provides a permeate suitable for feeding directly into the RO/UV post-treatment stage

Cross-media effects

If treatment is required before reuse, energy is consumed and chemicals may also be consumed.

Technical considerations relevant to applicability

Applicable in new and existing installations.

Economics

No information provided.

Driving force for implementation

Reduced costs associated with waste water treatment and energy consumption.

Example plants

No information provided.

Reference literature

[14, VITO et al. 2001], [61, UK 2002], [110, CIAA 2003]

8.4.3 Techniques to reduce waste

8.4.3.1 Separation of residues

This technique is described in Section 2.3.5.3.

There are likely to be many other opportunities to apply this technique within the sector:

- remove fine organic material when, for example, potatoes are brought into the installation;
- restrict sorting, spillage and splash losses by fitting collecting trays, flaps and screens;
- use dry separation and collection of solids, semi-solid residues and rejected raw material, e.g. in sorting, trimming, extraction and filtration;
- separate solid organic material from the waste water of the peeling process using, for example, sieves, filters and centrifuges, to restrict leaching;
- fit flaps and screens on conveyor belts.

Technical considerations relevant to applicability

Applicable to all fruit and vegetable processing installations.

Reference literature

[14, VITO et al. 2001]

8.4.3.2 Use of automatic sorting machines, to reduce raw material losses

Description

Impurities in the raw materials are removed with the use of automatic sorting machines.

Technical description

By using sorting machines, impurities in the raw materials can be removed (e.g. insects, infested or affected products). Putting the machine at the start of the production lines prevents imperfect products from passing the production line and having to be removed at the end of the line. Rejected products at any stage are a loss of product, but rejected products at the end of the production line cause an additional loss in energy/water/auxiliary products.

Depending on the type of fruits or vegetables, the principle of the sorting machine will be different and will be based on:

- size (e.g. by means of sieves);
- weight (e.g. by means of flotation and sedimentation equipment);
- colour (e.g. by means of optical sorting units);
- material (e.g. by means of a metal detector).

Achieved environmental benefits

Direct: reduced raw material losses.

Environmental performance and operational data

No information provided.

Cross-media effects

No information provided.

Technical considerations relevant to applicability

Generally applicable.

Economics

The investment and operating costs have to be in line with the raw material cost savings.

Driving force for implementation

Optimise the use of raw materials. Cost savings downstream in the production line: energy, water, auxiliary products, quality control. Higher quality of the end product.

Example plants

No information provided.

Reference literature

[87, Belgium-VITO 2015]

8.4.3.3 Recovery of starch in potato processing**Description**

Starch is recovered at different points in the production process and from waste water.

Technical description

The process streams and waste water from the potato processing industry contain high concentrations of starch. This starch can be recovered at different locations in the production process. Depending on the place in the production process, a distinction is made between white and grey starch.

White starch is starch that has not been heated above 40 °C. This starch has typical starch properties and can be used as raw material in the paper, adhesive and bioplastics industries. White starch is recovered in the water upstream of the blanching zone, usually at the blades.

Grey starch is starch which is discoloured after being heated. This starch can be recovered before the waste water enters the WWTP (or as the first step of the WWTP). This starch may be used as feed or be directed to the digester.

To recover starch, the purge of the cutting blades is directly connected through a cyclone. The concentrate stream is further concentrated by evaporation in a vacuum press. The recovery rate is about 51 kg starch be per tonne of fries.

Achieved environmental benefits

Recovery of valuable side streams.

Environmental performance and operational data

The concentrate stream is further concentrated by evaporation in a vacuum press. The recovery rate is about 51 kg of starch be per tonne of fries.

Cross-media effects

No information provided.

Technical considerations relevant to applicability

Restricted to the production of potato products.

Economics

The starch production (side stream) leads to an extra income of EUR 2 per tonne of potatoes. It also leads to less organic matter in the waste water plant. Taking this into account, the payback period is about 2 years.

Driving force for implementation

- Economic value of recoved starch.
- Lower operational cost of the WWTP.

Example plants

No information provided.

Reference literature

[87, Belgium-VITO 2015]

8.5 Emerging techniques

8.5.1 Water recycling at the washing step for freshly cut vegetables after an O₃/UV treatment

Description

Recycling of water at the washing step after O₃/UV treatment.

Technical description

This technique describes the recycling of water in the washing step after a treatment to reduce the microbial and organic load using a sequential treatment with ozone and UV radiation. Washing is one of the first steps of processing freshly cut vegetables in which vegetables are transported to a first washing tank or to a shower line where they are washed with drinking water to remove debris and then directed to the disinfection tank. In the washing step, in addition to the water contained in the washing tank, there is a continuous input of drinking water to maintain the quality of the washing water, mainly in terms of microorganisms and organic load, in such a way as to prevent cross-contamination during the processing period. The continuous consumption of drinking water can be between 3–6 m³/h, or even more than 12 m³/h if there is no disinfection step with chlorine, as is the case in some EU countries (for example the Netherlands).

The technique involves the complete or partial recirculation of water in the washing step of processing freshly cut vegetables after an O₃/UV treatment, in order to reduce the water consumption. Washing water from the recirculation tank is treated first with ozone, which destroys microorganisms by the oxidation of vital cell components, thus preventing microbial growth. Moreover, ozone oxidises the organic matter dissolved in the washing water, so that the organic load concentration can be maintained/reduced over time. A final treatment with UV radiation increases the global hygienic efficiency of the system and removes the remaining dissolved ozone in the water in order to prevent any damage to minimally processed vegetable (MPV) quality and labour risks when working with open tanks. The main products of the reaction with ozone are oxygen, water and carbon dioxide. As ozone decomposes rapidly, it does not accumulate. Additionally, ozone treatment is also beneficial for the subsequent waste water treatment since it oxidises most of the organic matter, reducing the COD of the final waste water. Electricity is the only input necessary for O₃/UV treatment. Chemical addition is not necessary for the process.

The treatment of water with an O₃/UV system requires the consumption of electricity in several steps: O₂/O₃ production, O₃ dissolution in water, destruction of O₃ excess, and UV treatment. Energy consumption for ozone production and effective dissolution in water is 4.59 MJ/m³ of ozonated water. However, a comparative LCA assessment developed by the SUSCLEAN project showed that the increase in energy consumption due to O₃/UV treatment is compensated by a reduction of the electricity consumption associated with the supply of process water (pumping of water, water treatment, water cooling) and a reduction of the energy consumption in waste water treatment.

Achieved environmental benefits

Reduction of water consumption.

Environmental performance and operational data

This technique was tested in the SUSCLEAN project at pilot plant scale and obtained good environmental results.

The recirculation of water at the washing step of processing freshly cut vegetables after an O₃/UV treatment achieved a reduction in water consumption around 22 %, while the hygienic level of the washed water was maintained for a time period of 90 minutes.

Ozone reduces the organic matter content in the washing waste water (analysed as COD) by 35 %. Ozone and UV treatment also has effect on the degradation of pesticides. In the experimental test, the concentration of orthophenylphenol was reduced to values lower than 0.1 mg/l.

Cross-media effects

No information provided.

Technical considerations relevant to applicability

Due to its oxidant properties, ozone may react with some materials and lead to corrosion of equipment and facilities. The compatibility of the existing materials should be checked to allow for changes if necessary.

Economics

The investment for a complete O₃/UV system (ozone generator, hydrokinetic mixer, contact tower, ozone in air destructor, UV system, ozone monitoring) for treating 4 m³ water per hour with an ozone concentration of 12 ppm with a retention time of 2.5 minutes can be around EUR 70 000.

Operational costs will depend on the local price of electricity and water and the cost of waste water treatment and waste water taxes.

Driving force for implementation

Reduction in costs for waste water treatment.

Example plants

SUSCLEAN pilot plant.

Reference literature

[231, SUSCLEAN 2015]

8.5.2 Use of NEOW as an alternative to conventional sodium hypochlorite for disinfection of salads

See also Section 2.4.2.

Description

Application of neutral electrolysed oxidising water (NEOW) as an alternative to conventional sodium hypochlorite for disinfection of salads.

Technical description

This technique involves the implementation of NEOW in the decontamination step of food products. It replaces the conventionally used sodium hypochlorite, minimising the chlorine input as well as the residue free available chlorine in the waste water.

NEOW is obtained by electrolysis of a diluted salt solution. This electrolysis results in the formation of two streams. On the anode side, an acid solution consisting of hypochlorous acid and hydrochloric acid is produced while an alkaline solution forms on the cathode side, consisting of sodium hydroxide. Additionally, depending on the voltage applied, oxygen and chlorine gas (anode side) as well as hydrogen gas (cathode side) may occur.

The effective component of the electrolysed oxidising water is the hypochlorous acid (HOCl), which is generated on the anode side (acid solution) and mainly known for its good disinfectant properties. As a strong oxidising agent, HOCl penetrates the cell wall of the microorganisms and disrupts the membrane transport proteins, the consequence being that the protein synthesis inside the cell is disrupted.

Achieved environmental benefits

The main potential environmental benefit to be gained through the implementation of NEOW in decontamination and sanitation processes in the MPV industry is the decomposition of the NEOW back into sodium hydroxide. Thus an additional activated carbon treatment of the waste water can be omitted and the waste water may be fed directly into a municipal sewage treatment plant.

NEOW is expected to exhibit easier control and measurement possibilities, allowing a more efficient dosage and thus decreasing the the material input.

Environmental performance and operational data

Operational data have been reported from the NEOW tests in the framework of the SUSCLEAN project:

- electrical consumption of the NEOW generator per day: 4.32 kWh;
- maximum free available chlorine concentration reached: 29 ppm;
- production rate: 0.7 l/min;
- sodium chloride intake: 0.21 kg NaCl/l NEOW.

Cross-media effects

Due to the production by electrolysis, the application of NEOW has a higher electrical energy demand in comparison to the application of sodium hypochlorite.

NEOW production requires the consumption of salt (NaCl). The non-optimised feed rate of salt used in the initial industrial-scale test conducted in the framework of the SUSCLEAN project was 0.21 kg NaCl/l of NEOW. However, this rate needs to be optimised with further industrial tests. The addition of NaCl for NEOW production increases the electrical conductivity of the waste water, which depends on the rate of salt consumption.

Furthermore, there is the risk of the occurrence of chlorine gas at the cathode of the electrolysis cell if an incorrect voltage is applied.

Technical considerations relevant to applicability

No information provided.

Economics

The operational cost could be EUR 850 per month. It generally depends on the local price of electricity and water but also the cost of waste water treatment and waste water taxes.

Driving force for implementation

No information provided.

Example plants

No information provided.

Reference literature

[231, SUSCLEAN 2015]

9 GRAIN MILLING

9.1 General information about the sector

One of the leading food industries in European grain processing is the flour milling industry, using around 45 million tonnes of soft wheat and rye a year to produce around 35 million tonnes of flour on an annual basis (EU-27). The number of flour milling companies exceeds 3 800, of which the large majority are small and medium-sized companies. The industry employs about 45 000 people and has a turnover of EUR 15 billion. The average production level represents the use of about 65 % of the industry's capacity [221, European Flour Millers 2016].

9.2 Applied processes and techniques

9.2.1 General overview

There are a number of cereals that are important food sources. These include wheat, barley, maize, oats, rye and rice. Wheat and rye grain is milled into flour. Durum wheat is milled into semolina and is generally used to make pasta. Soft wheat is the prime ingredient used in the manufacture of products such as bread and biscuits. In some countries, rye is used for bread. Barley is mainly used for animal feed. Barley of a certain quality is processed to malt and then used in brewing and distilling for example. Maize is used as a source of starch but also as an ingredient in breakfast cereals and snack foods. Oats are used for cereals, cakes, biscuits and also for making crispbread. Rice, along with wheat and maize, is one of the major cereals of the world and is the basic food for much of the world's population. Rice is pearled and sometimes precooked.

The wheat grain has three main components, the skin or bran, the embryo or germ, and the endosperm, which makes up the majority of the grain. The object of the milling process is to separate the endosperm with minimal contamination from the bran and germ. The main operations associated with flour milling are cleaning, conditioning, breaking, scalping, purification, reduction and dressing. In durum wheat mills, before the breaking phase, there is a debranning system, which consists of sequential separation of the outer bran layers from the grains of wheat.

The incoming grain is transferred to bulk silos prior to further processing. Gas or heat treatment may be applied to prevent insect infestation. The grain is first cleaned by passing it through a series of screening, scouring, brushing and aspiration operations. These processes remove extraneous matter such as other cereals, stones, metal contaminants, chaff, loosened bran layers, seeds and dust. After cleaning, the grain is conditioned to optimise the milling process. This involves dampening the grain by the measured addition of water, which immediately binds the kernels. Conditioning may be carried out by using steam. Conditioning has a number of functions, such as toughening the bran, and thereby improves the separation of the bran from the endosperm, allowing the endosperm to be reduced more effectively in subsequent stages of the process.

The conditioned grain enters the break system of the mill, which consists of pairs of corrugated rollers which revolve in opposite directions and at different speeds. Five sets of break operations are common, with the aperture gradually decreasing and the corrugation becoming finer between subsequent sets. The grain is split by the break-rollers and the endosperm is scraped from the bran. A screening operation known as scalping or grading is carried out after each break-roller. This operation separates:

- coarse particles which contain the remains of the grain and some endosperm which is yet to be recovered;
- particles of intermediate size which contain chunks of endosperm which are called semolina or middlings, depending on their particle size and purity;
- flour.

Semolina, flour and middlings pass through a purification system consisting of sieving and air classification. This removes particles of endosperm with bran adhering to them for further treatment by fine rollers. The semolina, flour and middlings are then transferred onto reduction rollers, which are smooth and whose purpose is to crush the endosperm. As in the break section of the mill, there are a series of rollers and screening operations, so that flour is screened off whilst the coarser endosperm, retained on the sieves, passes to another set of reduction rollers to be further reduced in size. At the end of the reduction process, most of the endosperm will have been converted to flour, the coarse bran will have been removed and there will be a third stream of endosperm consisting of material containing fine bran which cannot be practically separated. There could be as many as 12 reduction stages in the process. Flour is normally passed over a

final redresser at the end of the milling process or after bulk storage to remove any residual foreign bodies. Flour may be dried and classified by sieves into fractions. Practice varies in different MS, e.g. in the UK, 25 % is bagged for delivery to bakers and other food manufacturers and 70 % is delivered in bulk, whereas, in Portugal, the proportions are almost exactly the other way round.

Grains such as oats and barley, with a tightly adhering husk cannot simply be separated in a traditional wheat mill and are usually subjected to an abrasion process called pearling prior to milling.

9.2.2 Specific processes

In addition to the traditional process of grinding, some activities (e.g. turboseparation or steaming) can complement the processing of the flour to separate the different constituents (by granulometry) or to reduce the water content. Some specific markets (e.g. baby food) need flours with specific specifications (drier or high protein).

These activities represent a not insignificant part of the energy consumption (even if only 10–20 % of the flour produced is processed during these steps) or could have specific requirements for dust abatement. Turboseparation and steaming may represent 30 % of the total energy used on a site [56, ANMF 2017].

Steaming and turboseparation activities never apply to all the flours produced and, depending on the markets, these activities are more or less developed (specific activities that can vary greatly depending on markets and customers' requirements). More detail is given below [56, ANMF 2017]:

Steaming

Steaming usually reduces the flour moisture content from 15 % to 10–12 % (5 % maximum). There are two principles of steaming, both energy-intensive (gas or electricity):

- By contact with a hot surface.

The walls of a mechanical system, Archimedes screw type or mixer, are heated by a fluid (usually water). The flour, in contact with its walls, releases a part of its moisture. A suction system completes this process.

- By heat exchange during a pneumatic transfer.

The flour is injected into a pneumatic hot-air transport system (drying circuit). This air is preheated. The partially dehydrated product is separated from the transport air loaded with moisture at the hot filter. The flour is injected into a second pneumatic transport system (cooling circuit). The cooling air is separated from the dehydrated flour at the cold filter.

Some flours can support more rigorous drying: final flours can reach a moisture content of less than 3 %. It should be noted that the energy required for steaming depends on the initial and final moisture content: the energy to reduce the moisture of a flour by 1 % is higher when its moisture is lower.

Turboseparation (or micronisation)

This process separates and classifies the flour particles according to their mass and their volume using the aeraulic technique. The separation is done by centrifugation in air transport, an operation which requires high-power engines. A low-protein fraction and a fine high-protein fraction are obtained.

9.3 Current consumption and emission levels

9.3.1 Energy consumption

Figure 9.1 shows data on specific energy consumption (MWh/tonne of products) in various grain milling installations.

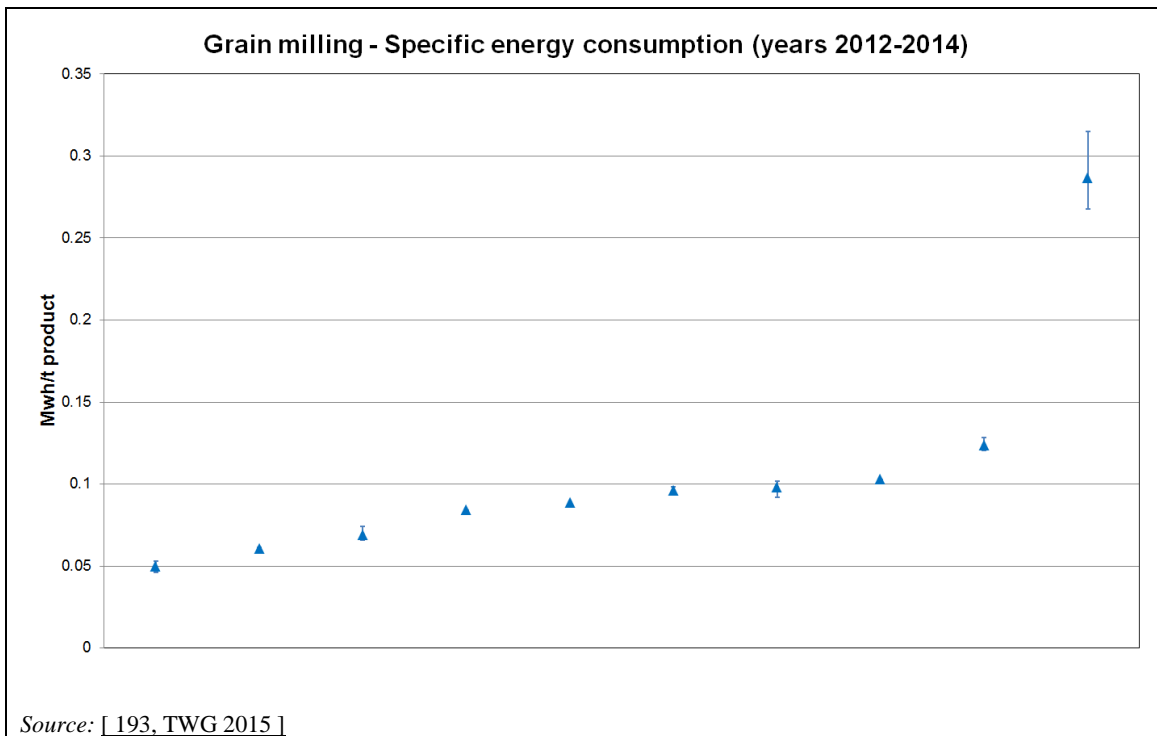

Source: [193, TWG 2015]

Figure 9.1: Specific energy consumption (MWh/tonne of products) in grain milling

9.3.2 Water consumption

Figure 9.2 shows data on specific water consumption (m^3/tonne of products) in various grain milling installations.

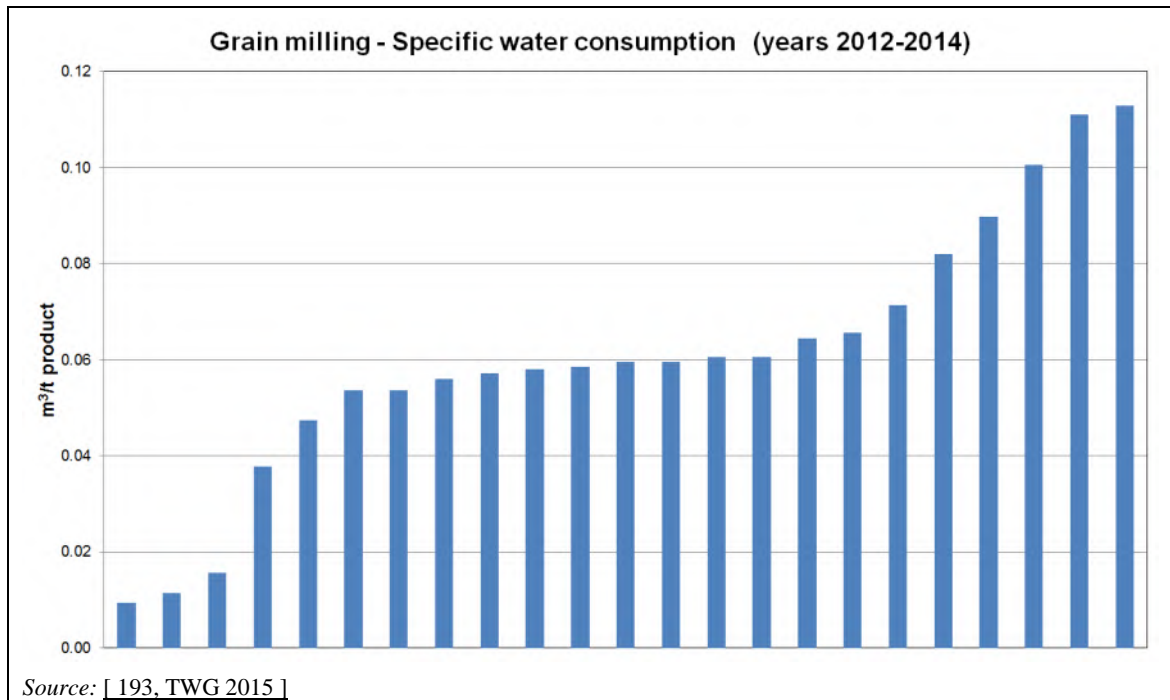

Figure 9.2: Specific water consumption (m^3/tonne of products) in grain milling

Generally, water consumption is strictly linked to the temperature and humidity of the grain. For example, the grain cultivated in southern Italy grows in a dry and hot climate and arrives at the mill with a low moisture content (average of 11.90 %). Therefore, it is necessary to wet the grain before milling with a large quantity of water, in order to maintain the moisture content required by national laws (e.g. 14.5 % in Italian and French legislation).

9.3.3 Emissions to air

9.3.3.1 Dust emissions

Bag filters are predominantly used for the treatment of dust emissions to air from the grain milling process. The most relevant emission source is the milling itself, although cleaning operations can also be relevant. A general overview of the data received for dust emissions from the whole grain milling process is shown in Figure 9.3 (lower values) and Figure 9.4 (higher values). The applied end-of-pipe abatement techniques are also indicated. Dust emission loads are usually below 200 g/h from a single point of release.

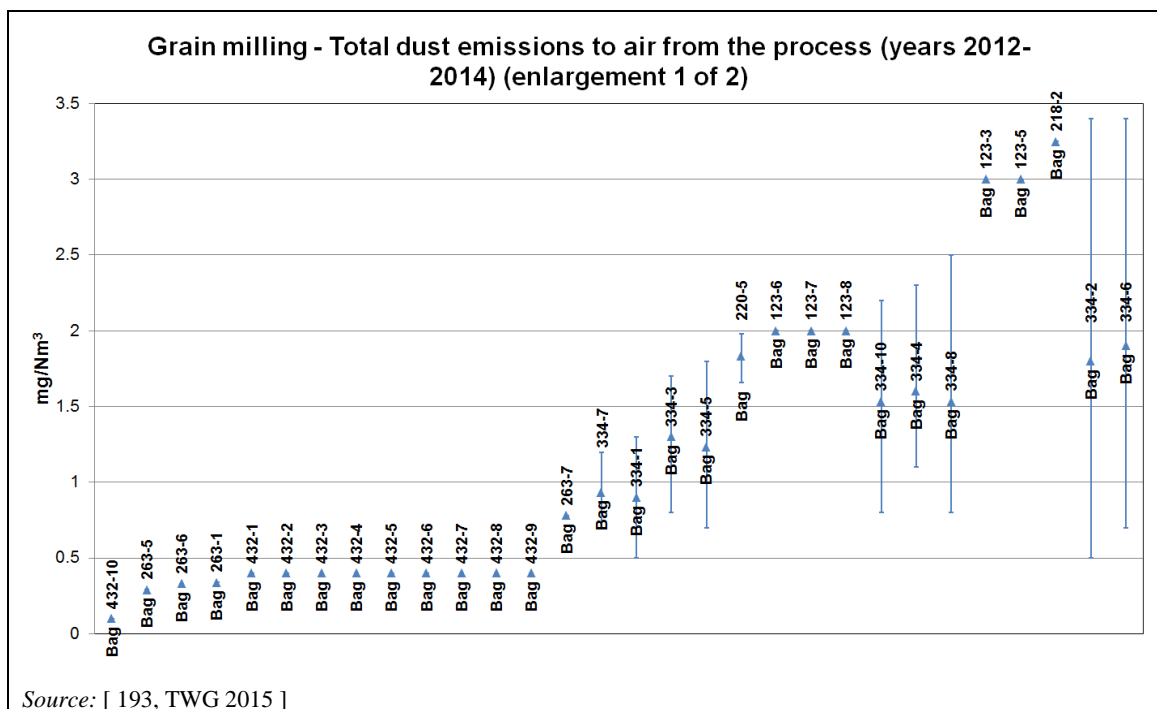

Figure 9.3: Total dust emissions to air from the grain milling process (1 of 2)

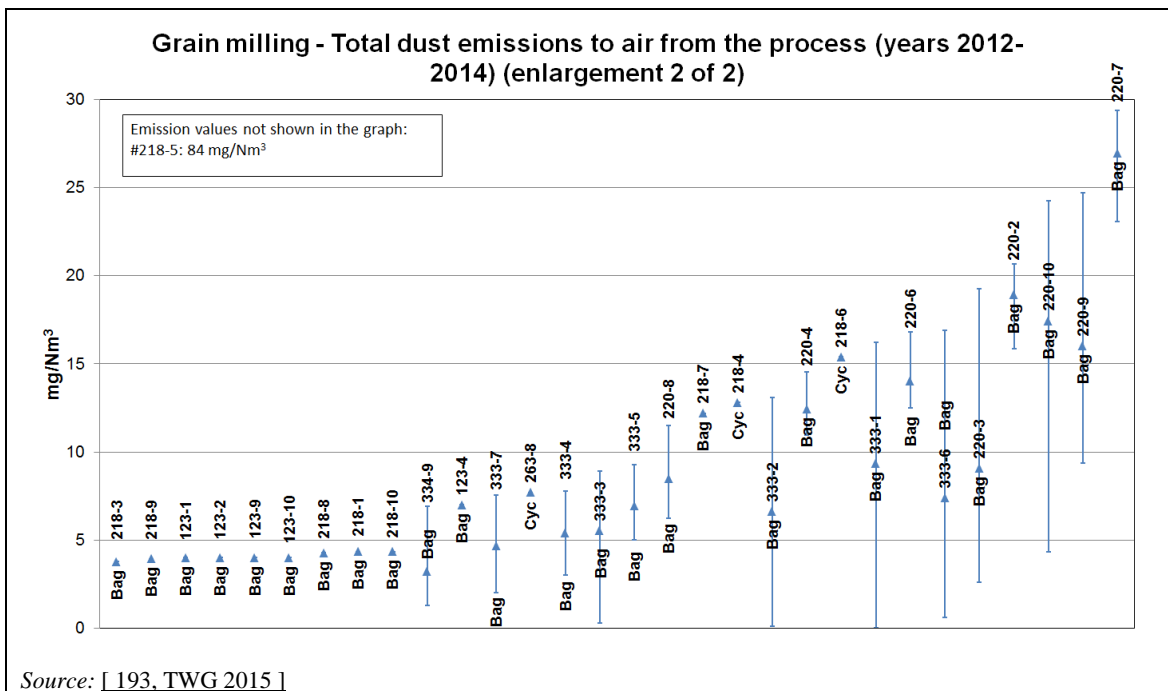

Figure 9.4: Total dust emissions to air from the grain milling process (2 of 2)

The meaning of the symbols and abbreviations used in Figure 9.3 and Figure 9.4 are indicated in Table 3.3 and Table 3.4.

9.4 Techniques to consider in the determination of BAT

9.4.1 Techniques to reduce emissions to air

9.4.1.1 Techniques to reduce dust emissions from the grain milling process

9.4.1.1.1 Bag filter

General information on the technique is given in Section 2.3.7.2.2.

Environmental performance and operational data

Table 9.1 shows installation-specific performance data related to the application of bag filters for abating emissions to air from grain milling processes.

Table 9.1: Total dust emissions to air from the grain milling process after treatment in a bag filter (dry basis)

Installation ID-point of release	Dust (mg/Nm ³)	O ₂ content (%)	Monitoring standard	Frequency of monitoring	Additional information
263-12	< 0.30	NI	EN 13284-1	Once every three years	Wheat processing Milling process Tubular filter
432-12	0.10	NI	Micro dust meter	Yearly	Wheat processing Milling process Medium-Pressure Reverse Jet Filter
263-5	0.29	NI	EN 13284-1	Once every three years	Wheat processing Wheat press Tubular filter
333-3	0.30	20.9	EN 13284-1	Yearly	Wheat processing Debraining general aspiration
263-11	0.32	NI	EN 13284-1	Once every three years	Wheat processing Milling process Tubular filter
432-6	0.40	NI	Micro dust meter	Yearly	Wheat processing Flour blending Medium-Pressure Reverse Jet Filter
263-7	0.78	NI	EN 13284-1	Once every three years	Processing wheat Wheat cleaning Tubular filter
334-1	0.90	NI	EN 13284-1	Yearly	Wheat processing Wheat cleaning
220-9	< 1	21.0	NI	Twice a year	Wheat processing Milling process
334-3	1.40	NI	EN 13284-1	Yearly	Wheat processing Milling process
334-4	2.30	NI	EN 13284-1	Yearly	
333-2	1.45	20.90	EN 13284-1	Twice a year	Wheat processing Wheat cleaning
334-9	1.50	NI	EN 13284-1	Yearly	Wheat processing Flour transfer
220-2	< 1.74	21.00	NI	Twice a year	Wheat processing Reception silo
220-10	< 2	21.00	NI	Twice a year	Wheat processing Milling process

123-7	2.00	NI	NI	NI	Wheat and rye processing Milling process
432-17	2.50	NI	Micro dust meter	Yearly	Wheat processing Wheat cleaning Tubular filter
123-5	3.00	NI	NI	NI	Wheat and rye processing Wheat mill and flour silo
334-6	3.40	NI	EN 13284-1	Yearly	Wheat processing Wheat discharge
333-1	4.00	20.90	EN 13284-1	Twice a year	Wheat processing Raw materials silo
333-6	6.00	20.90	EN 13284-1	Twice a year	Wheat processing Milling process
218-7	12.19	NI	NI	NI	Wheat processing Thermo-pneumatic semolina mill
NB: NI = no information provided. Source: [193, TWG 2015]					

The dust from grain milling often has a high protein content together with a small particle size, which may be regarded as potentially harmful [30, TWG 2018].

Reference literature

[30, TWG 2018], [193, TWG 2015]

9.4.1.1.2 Cyclone

General information on the technique is given in 2.3.7.2.3.

Environmental performance and operational data

The application of cyclones to abate emissions to air from the grain milling process is not reported as often as the application of bag filters. Moreover, dust emission levels from a cyclone are generally higher those from a bag filter.

Table 9.2 shows installation-specific performance data related to the application of bag filters for abating emissions to air from grain milling processes.

Table 9.2: Total dust emissions to air from the grain milling process after treatment in a cyclone (dry basis)

Installation ID-point of release	Dust (mg/Nm ³)	O ₂ content (%)	Monitoring standard	Frequency of monitoring	Additional information
263-8	7.70	NI	EN 13284-1	Once every three years	Wheat processing Flour transfer Moist waste gas
218-4	12.81	NI	NI	NI	Wheat processing Semolina mill cleaning
218-6	15.39	NI	NI	NI	Wheat processing Pruning machine
NB: NI = no information provided. Source: [193, TWG 2015]					

Reference literature

[193, TWG 2015]

10 MEAT PROCESSING

10.1 General information about the sector

Processed meat (cooked, cured, canned, etc.) constitutes the largest and most dynamic part of EU meat consumption. It is a market with added value and opportunity for marketing and innovation in product development, packaging and branding.

Modern retail is the main outlet for processed meat distribution. It represents nearly 84 % of European processed meat retail sales. However, products, brands and merchandising differ enormously from one retail chain and one country to another. Counter-service sales can vary from as little as 6 % of sales in the UK to around 70 % in Italy. While the presence of fresh-prepack is growing, traditional stores are still important outlets for processed meat in many countries [151, Clitravi-Avec 2016].

The meat processing sector represents the downstream part of the meat production value chain. It consists of all the activities related to the production of meat preparations and meat products. The sector is composed of more than 24 000 companies in the EU-28 and has a total production value of EUR 86 billion. It employs more than 421 000 people, one of the largest sectors of the whole EU food processing industry [151, Clitravi-Avec 2016].

The EU meat processing sector is characterised by a majority of SMEs (90 %) with a high level of specialisation operating independently at different stages of the supply chain. This is particularly the case for the pig meat and beef meat sectors. Larger vertically integrated companies (owning slaughterhouses, processing facilities and storage), in terms of numbers, represent a small share of all companies operating in the EU meat processing industry and tend to be more prevalent in the poultry sector [151, Clitravi-Avec 2016].

The EU-28 meat production based on the 2014 slaughtering statistics was as follows: pig meat was the most significant meat category, over 22.1 million tonnes were produced, 51 % of the annual production of all meats; followed by poultry meat with 13.0 million tonnes (30 %). Bovine meat production totalled 7.3 million tonnes (17 %) and the meat from sheep and goats together accounted for only 0.8 million tonnes, around 2 % of all meat [174, Eurostat 2016].

Growth in world meat consumption is driving changes in EU meat production, which is expected to increase only slightly in the next 10 years, to 46.5 million tonnes. Population and economic growth in developing countries, albeit slower than in the previous decade, are expected to support higher meat demand and contribute to the growth of EU meat exports. World meat consumption is expected to increase by 1.4 % a year between 2015 and 2025, slower than in the previous decade (2.1 %), to 358 million tonnes. In 2014, EU meat consumption was 66.3 kg per capita. Figure 10.1 shows the total meat consumption in the EU for the period 2000-2024 [219, COM 2015].

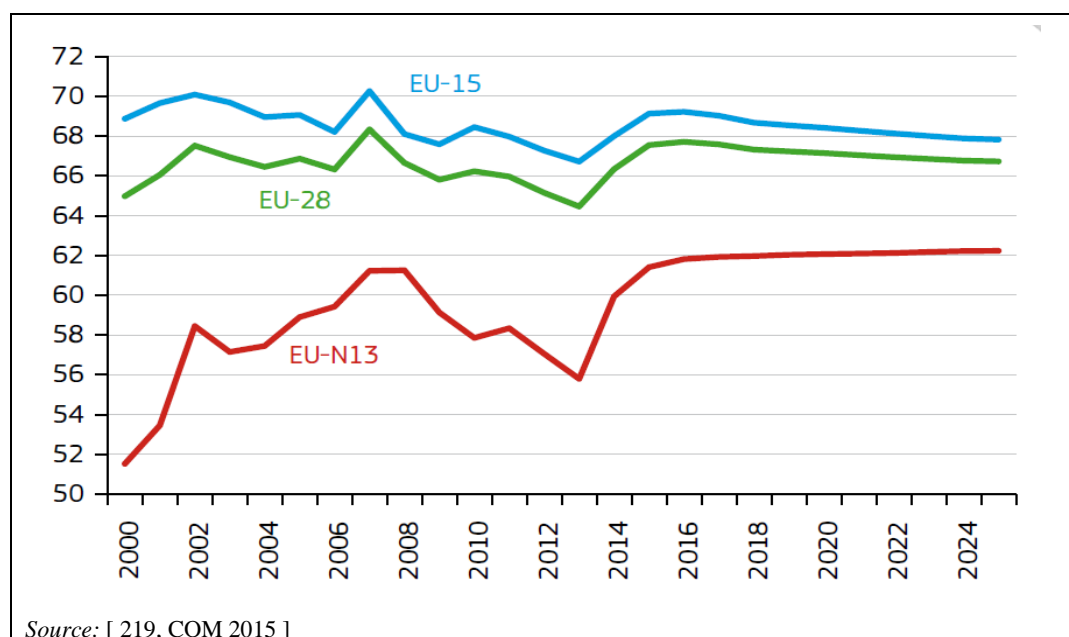

Figure 10.1: Total meat consumption in the EU in kg per capita (retail weight)

The consumption of meat products in the EU is not expected to rise over the coming years, due to growing social concerns (animal welfare and carbon footprints), health concerns and an ageing European population (eating less meat per capita). Some of these factors serve to favour poultry over other meats [219, COM 2015].

Below some further data are provided by type of processed meat [151, Clitravi-Avec 2016].

In 2013, the production of poultry meat in the EU-27 was almost 12.9 million tonnes. In the poultry meat supply chain, different companies are involved in supplying and slaughter/processing. Poultry is slaughtered in slaughterhouses and the meat is further processed into consumer products in processing companies.

In 2012, the total production of poultry meat was 12.9 million tonnes with a value of EUR 24.6 billion. However, this is the economic output of the primary sector and slaughterhouses only. No official data are available on the total production value of poultry after further processing; however, according to estimations, the value is 30 % higher after processing. Based on that, the total production value of poultry meat in the EU-27 in 2012 would amount to EUR 32 billion, meaning that the EU further processing poultry meat sector can be estimated at EUR 7.4 billion.

In terms of value, bovine animals represent 8.1 % of total agricultural output and 18.8 % of animal output, without taking animal products (e.g. milk) into account. In Europe, more than two thirds of the bovine meat is supplied by the dairy herd.

The EU consumes about 7.8 million tonnes of beef each year (both fresh meat and processed meat), with the key high-value cuts segment of the market amounting to about 500 000 tonnes. Imports into the EU amount to over 300 000 tonnes and the import requirement in the coming years is not predicted to go much beyond 400 000 tonnes.

Pig meat represents 9.0 % of the total EU agricultural output. As already highlighted, pig meat is the major type of meat produced in the EU-28.

The EU pig meat sector has the largest share of processing compared to other meat sectors. In total, an estimated 70 % of the EU processed meat production volume is made up of pig meat.

Sheep and goat meat represents 1.4 % of the total EU agricultural output. The overall contribution of goat meat to the EU-28 meat production is modest (0.1 %) and is concentrated in seven EU Member States, representing 95.6 % of the total EU goat meat production. The EU sheep sector has witnessed downward pressure on production over recent years with reductions in flocks and pressure on income. However, it is expected that, over the coming years, demand in the European market will outstrip production levels, which could provide opportunities for exporting countries.

While the main consumer demand is oriented to fresh meat, added-value product areas include irradiated products for microbial safety, precooked products for convenience, portioned and institutional items for uniformity, and nutritionally enhanced meat for healthfulness.

10.2 Applied processes and techniques

10.2.1 General overview

Pork, poultry and beef are the main types of meat processed in Europe. The activities of the meat sector can be divided into three areas, slaughtering (covered by the SA BREF [93, COM 2005]), meat cutting and further processing. For the scope of this BREF, the slaughtering activity is considered to end with the making of standard cuts for large animals and cuts for poultry.

Meat processing technology comprises the steps and procedures in the manufacture of processed meat products. These treatments go beyond the simple cutting of meat into meat cuts or meat pieces with subsequent cooking for meat dishes in order to make the meat palatable and involve a wide range of methods. Table 10.1 shows a brief description of the typical processes applied in the meat sector.

Table 10.1: Typical processes applied in FDM meat processing installations

Process	Brief description
Boning	Separation of meat, bones and fat – typically done at the slaughterhouse as a manual or a semi-manual process. In the boning process, primary cuts are separated into muscles and meat/fat mixes (mixes with different meat/fat contents, e.g. 50/50 (%)). Typically a meat processing installation buys the specific cuts/muscles and meat/fat mixes needed for the planned production.
Cutting, trimming	Cutting / dicing / trimming of meat/muscles according to the size and shape needed for the specific product. Offcuts are used in other products / for minced meat, etc.
Fat standardisation	Measuring of fat content of meat/fat and mixing of different batches to obtain the fat content required according to the recipe for the product.
Mixing	Mixing of meat and auxiliary materials. Typical mixing of minced meat and auxiliary materials.
Salting, dry salting, vessel salting, injection	Adding salt to the product: <ul style="list-style-type: none"> • Dry salting, storing meat pieces in dry salt until the necessary degree of salting is obtained. • Vessel salting; storing the meat in brine until the necessary degree of salting is obtained. • Injection of brine to the product, typically followed by tumbling to obtain uniform distribution of salt in the product.
Marinating	Adding marinade to the product.
Adding additives, preservatives, flavour and enzymes	Adding additives, preservatives, flavour and enzymes to improve functionality, shelf life or flavor of the product.
Tumbling	Tumbling of the product to ensure a uniform distribution of salt/marinade in/on the product.
Mincing	Mincing/chopping of the meat using meat grinders/meat mincers reducing the size of the meat particles by 1 to 2 centimetres, and bowl choppers/meat cutters for further reduction of the particle size. In bowl choppers and meat cutters, auxiliary materials can be added during the process.
Emulsification, production of minced meat	Final mixing of the minced meat and auxiliary materials using a meat emulsifier. A grinder function can be included for further reduction of the size of the meat particles.
Forming	Forming of minced meat to meatballs, burgers etc. – a continuous and automated process. Putting products into forms, typically a manual or semi-automated process.

Process	Brief description
Filling cans and autoclaving	Comprises the following process steps: <ul style="list-style-type: none"> • Cleaning of cans before filling • Filling of cans • Refilling before closing the can • Sealing of lid • Washing after sealing • Autoclaving • Cooling of the canned products
Filling sausages/Stuffing sausages	Filling of sausage meat into casings.
Breading	Coating the product with breading or batter – typically before deep-frying.
Wrapping	Wrapping of products in sausage meat, e.g. Scotch eggs or wrapping of the filling/stuffing in spring rolls, etc.
Baking	Heat treatment of products in an oven – the baking process can be either a batch process, or a continuous process in a tunnel oven.
LTLT/sous vide heat treatment	LTLT; Long-Time Low-Temperature Sous vide; (vacuum) Vacuum packing of product followed by heat treatment in a hot water bath. Packed meat/products are immersed in hot water of approximately 55–70°C for a long time (hours/several hours). Applying the LTLT/sous vide process reduces product loss during heat treatment compared to normal heat treatment. Heating and the following chilling can be performed in the same vessel or in two vessels – one for cooking and one for cooling.
Cooking	Cooking of products, immersed in water or by saturated air heated by steam. Cooking can be made in batch cookers or in continuous cookers.
Deep-frying	Frying in a heated oil bath. The products are placed on a conveyor and transported through a bath of heated oil.
Belt-frying	Frying between two heated belts, one under and one on top of the product. By using belt-frying equipment, the products look like products produced in a frying pan.
Hot smoking	Hot smoking is carried out at temperatures denaturing the proteins, usually 65–90 °C. Smoking provides flavour and colour and preserves the product. Smoking can either be carried out in smoking chambers as a batch process or it can be a continuous process. Smoke can be produced by controlled burning of woodchips (hardwood) or by friction between the wood and a metal wheel.
Cold smoking	Smoking by applying cold smoke, at temperatures of 30–55°C which do not denature the proteins. Controlled burning of wood (hardwood) typically produces the smoke.
Fermentation, maturing	Fermentation of meat products using natural starting culture present in the product or starting culture added to the product. Maturing improves texture and flavour.
Drying	Removal of water from the product. The process can take place in a climate chamber where temperature and air humidity are controlled.
Cooling after heat treatment	Cooling – removal of heat from the product. Further description in the next chapter.
Freezing	Freezing – for preservation of the product. Further description in the next chapter.
Shell freezing	Freezing the outer layer of the product before slicing. To optimise the slicing process and to reduce product loss.
Slicing	Slicing of larger pieces of products. Prior to the slicing, shell freezing can be used to ensure the uniformity of the slicing and reduce product loss during the slicing. Slicing is typically followed by packing – consumer packing or bulk packing.
Packing, consumer	Packing and labelling of products for supermarkets.
Bulk packing	Packing of products to be used in other production installations.

Source: [17, TWG 2018] [220, Clitravi-Avec 2016]

In more detail, cutting is the size reduction of large to medium-sized parts of food material. For cutting, knives, blades, cleavers and circular or straight saws are used. These are all electrically operated. Carcasses are cut into retail cuts of joints by the removal of bone, skin and fat. After cutting the meat, the fresh meat may be stored and dispensed under refrigeration. It can be sold in portions, or it may be combined with other products. Special derinding machines are used for separating rind and fat from pork carcasses.

The further processing of meat, e.g. into ham, bacon and sausage, is primarily carried out for preservation purposes but it is also important for taste. In the meat sector, raw meats, either whole muscles or altered meat particles, are restructured to the predetermined product characteristics.

For coarse-ground products, the meat particles are substantially reduced and then restructured back into a different physical form. The goal of muscle product processing is to keep an original intact tissue appearance in the finished product. Products, such as ham, roast beef and turkey breast, are produced from whole muscles or sectioned muscles. An emulsifying process forms a matrix in which the fat particle is encapsulated with the protein membrane.

Grinding reduces particle size, and mixing assures uniformity of chemical composition as well as protein extraction. Chopping also reduces particle size and produces salt-soluble protein. Major processing equipment includes injectors and massagers for muscle products, grinders and mixers for coarse-ground products, and choppers and emulsifiers for emulsified products. Injecting and massaging processes facilitate brine distribution and protein extraction.

The injection under pressure of a solution containing brining/curing/pickling ingredients is a widely used technique for extending the life of meat. The ingredients used are common salt, i.e. NaCl, often with sodium or potassium nitrite and other materials to impart special characteristics. This process is required for whole products such as ham, shoulder, bresaola and turkey. Traditional in-vein injection has ceased and today the technique uses multi-needle injectors, which allow a higher productivity and a major spread of pickle. The injector injects a predetermined dose of pickle containing different additives and ingredients, such as salts, polyphosphates, ascorbate, caseinate, nitrate, nitrite, glutamate and spices inside the ham or shoulder mass.

After the injections, a process which allows complete homogenisation of the ingredients and of the additives into the product takes place. This process also allows the extraction of a proteinous/saline fluid from the meat with binding effect. It involves massaging the meat inside a container turning around a vertical or inclined axis in a continuous or intermittent way, under vacuum and/or at a refrigerated temperature. Brining/curing by dry salt is required for the production of cured uncooked ham, bacon, and coppa. The latter two products can also be made in the massaging machine.

Preservation involving heat, e.g. cooking or frying, and dehydration produces foods that can be packaged and kept for an extended time at appropriate storage conditions. Preservation techniques such as fermentation, smoking, and brining/curing/pickling are used to diversify the market selection. All these processes offer a limited extension of the shelf life by altering the environmental conditions which support microbial growth.

Smoking is the process of cooking, preserving or flavouring food by exposing it to smoke. There are two types of smoking. Hot smoking is typically carried out at 65–120 °C and can be used to fully cook foods. Hot smoking uses smoke generated from burning and smouldering wood. Cold smoking is typically carried out at 30–55 °C and is generally used to preserve or flavour foods. Cold smoking uses smoke generated from smouldering wood, smoke condensates (liquid smoking), friction and superheated steam. The different methods used for smoke generation are described in Table 7.2. The VOC content in the smoke depends, to a large extent, on the method of smoke generation. The method influences emissions and thus the need for air cleaning. The type of smoke chosen determines the flavour achieved.

Preservatives are generally added in meat products to ensure shelf life and safety during storage. Sodium chloride and sodium nitrite are commonly used in processed meat. Moreover, sodium lactate and sodium acetate are often used to stabilise ready-to-eat products against growth of pathogens, especially *listeria monocytogenes*. Salt reduction (sodium reduction) is a challenge to the food industry and for this reason an increasing use of potassium instead of sodium is observed. Other ingredients are also often added to processed products either for technical reasons, for example water binding (phosphates), or for improving texture (enzymes). Another use is for flavouring, for example spices or liquid smoke. Some of these have antimicrobial activity but the main reason for addition is flavour, as the effect of liquid smoke on an antimicrobial activity can vary considerably. Preservatives and other additives used in processed meat are controlled by Regulation EC 1333/2008 of the European Parliament and of the Council on food additives [17, TWG 2018].

To recover fat from meat residues, wet melting or dry melting is used. In the wet melting process, the raw material is heated in a process kettle by direct steam injection to a temperature of about 90 °C. This results in a watery phase and a fat-containing phase. The phases are separated by decantation and centrifugation. In the dry melting process, the raw material is indirectly heated in the processing kettle (a kettle with a steam jacket). All the water which evaporates is removed from the kettle under vacuum. The liquid phase or molten fat and the dry phase or fat-free meat residue are separated by decantation.

The meat sector is very diverse in terms of its products due to specific local tastes and traditions. A typical list of products of FDM meat processing installations is as follows [220, Clitravi-Avec 2016]:

- dried meat;
- cured ham;
- salted meat;
- smoked, salted meat;
- cooked sausages;
- sausages, without heat treatment;
- salami;
- cooked ham, restructured ham, etc.;
- canned meat;
- canned minced meat;
- pâtés and liver paste;
- cut out meat, fresh;
- cut out meat, frozen;
- enhanced pieces of meat, fresh;
- enhanced pieces of meat, fried;
- minced meat, fresh;
- meatballs;
- burger patties, fresh;
- burger patties, frozen;
- deep-fried meatballs, cooled;
- deep-fried meatballs, frozen;
- belt-fried meatballs, cooled;
- belt-fried meatballs, frozen;
- LTLT (Low-Temperature Long-Time) treated pieces of meat, etc.;
- LTLT treated minced meat products;
- soup and bouillon;
- cooled ready-cooked meal;
- frozen ready-cooked meal;
- chicken nuggets;
- pies (pâté en croûte, etc.);

- other meat preparations, fresh;
- ground meat mixture;
- breaded products.

A general overview of the main processes applied for different meat products is shown in Table 10.2.

Table 10.2: General overview of processes applied for different meat products

	Boning	Cutting, trimming	Fat standardisation	Mixing	Salting	Marinating	Tumbling	Mincing	Emulsification, production of minced meat	Forming	Filling cans and autoclaving	Filling sausages/Stuffing sausages	Breading	Wrapping (in sausage meat)	Baking	LTLT/vacuum heat treatment	Cooking	Deep-frying	Belt-frying	Hot smoking	Cold smoking	Fermentation, maturing	Drying	Cooling after heat treatment	Freezing	Shell freezing	Slicing	Packing, consumer
Dried meat	x	x	-	-	x	-	-	-	-	-	-	-	-	-	-	-	-	-	-	-	-	x	x	-	-	-	-	x
Cured ham	x	x	-	-	x	-	-	-	-	-	-	-	-	-	-	-	-	-	-	-	-	x	x	-	-	-	-	x
Salted meat	x	x	x	-	x	-	x	-	-	-	-	-	-	-	-	-	-	-	-	-	-	-	-	-	-	-	-	x
Smoked, salted meat	x	x	x	-	x	-	x	-	-	-	-	-	-	-	-	-	-	-	-	x	x	x	x	x	x	x	x	x
Cooked sausage	x	x	x	x	x	-	-	x	x	-	-	x	-	-	-	-	x	-	-	x	-	-	-	x	x	-	-	x
Sausages, without heat treatment	x	x	x	x	x	-	-	x	x	-	-	x	-	-	-	-	-	-	-	-	-	-	-	-	-	x	x	x
Salami	x	x	x	x	x	-	-	x	x	-	-	x	-	-	-	-	-	-	-	-	x	x	x	-	-	-	x	x
Boiled ham, restructured ham, etc.	x	x	x	x	x	-	x	-	-	x	-	-	-	-	-	-	x	-	-	-	-	-	-	x	-	x	x	x
Canned meat	x	x	x	x	x	x	x	-	-	-	x	-	-	-	-	-	x	-	-	-	-	-	-	x	-	-	-	-
Canned minced meat	x	x	x	x	x	x	x	x	x	-	x	-	-	-	-	-	x	-	-	-	-	-	-	x	-	-	-	-
Pâtés and liver paste	x	x	x	x	-	x	-	x	x	x	-	-	-	-	-	-	-	-	-	-	-	-	-	x	-	-	x	x

	Boning	Cutting, trimming	Fat standardisation	Mixing	Salting	Marinating	Tumbling	Mincing	Emulsification, production of minced meat	Forming	Filling cans and autoclaving	Filling sausages/Stuffing sausages	Breading	Wrapping (in sausage meat)	Baking	LTLT/vacuum heat treatment	Cooking	Deep-frying	Belt-frying	Hot smoking	Cold smoking	Fermentation, maturing	Drying	Cooling after heat treatment	Freezing	Shell freezing	Slicing	Packing, consumer
Cut-out meat, fresh	x	x	-	-	-	-	-	-	-	-	-	-	-	-	-	-	-	-	-	-	-	-	-	-	-	-	x	x
Cut-out meat, frozen	x	x	-	-	-	-	-	-	-	-	-	-	-	-	-	-	-	-	-	-	-	-	-	x	-	-	-	x
Enhanced pieces of meat, fresh	x	x	-	-	x	x	x	-	-	-	-	-	-	-	-	-	-	-	-	-	-	-	-	-	-	-	-	x
Enhanced pieces of meat, fried	x	x	-	-	x	x	x	-	-	-	-	-	-	-	-	-	x	x	-	-	-	-	-	x	x	-	-	x
Minced meat, fresh	x	x	x	x	x	-	-	x	x	x	-	-	-	-	-	-	-	-	-	-	-	-	-	-	-	-	-	x
Meatballs	x	x	x	x	x	x	x	x	x	x	-	-	-	-	-	x	x	x	-	-	-	-	-	x	x	-	-	x
Burger patties, fresh	x	x	x	x	x	x	x	x	x	x	-	-	-	-	-	x	-	-	-	-	-	-	-	x	-	-	-	x
Burger patties, frozen	x	x	x	x	x	x	x	x	x	x	-	-	-	-	-	x	-	-	-	-	-	-	-	x	x	-	-	x
Deep-fried meatballs, cooled	x	x	x	x	x	-	-	x	x	x	-	-	-	-	-	x	x	-	-	-	-	-	-	x	-	-	-	x
Deep-fried meatballs, frozen	x	x	x	x	x	-	-	x	x	x	-	-	-	-	-	x	x	-	-	-	-	-	-	-	x	-	-	x

	Boning	Cutting, trimming	Fat standardisation	Mixing	Salting	Marinating	Tumbling	Mincing	Emulsification, production of minced meat	Forming	Filling cans and autoclaving	Filling sausages/Stuffing sausages	Breading	Wrapping (in sausage meat)	Baking	LTLT/vacuum heat treatment	Cooking	Deep-frying	Belt-frying	Hot smoking	Cold smoking	Fermentation, maturing	Drying	Cooling after heat treatment	Freezing	Shell freezing	Slicing	Packing, consumer
Belt-fried meatballs, cooled	x	x	x	x	x	-	-	x	x	x	-	-	-	-	-	x	-	-	x	-	-	-	-	x	-	-	-	x
Belt-fried meatballs, frozen	x	x	x	x	x	-	-	x	x	x	-	-	-	-	-	x	-	-	x	-	-	-	-	-	x	-	-	x
LTLT treated pieces of meat, etc.	x	x	-	-	x	-	-	-	-	-	-	-	-	-	-	-	-	-	-	-	-	-	-	x	-	-	-	x
LTLT treated minced meat products	x	x	x	x	x	-	-	x	-	x	-	x	-	-	-	-	-	-	-	-	-	-	-	x	-	-	-	x
Soup and bouillon	x	x	-	-	-	-	-	-	-	-	x	-	-	-	-	x	-	-	-	-	-	-	-	x	x	-	-	x
Cooled ready-cooked meal	x	x	x	x	x	x	x	x	x	x	x	x	x	x	x	x	x	x	x	x	x	x	x	x	x	x	x	x
Frozen ready-cooked meal	x	x	x	x	x	x	x	x	x	x	x	x	x	x	x	x	x	x	x	x	x	x	x	x	x	x	x	x
Chicken nuggets	x	x	-	-	-	x	-	-	-	x	-	-	x	-	-	-	-	-	-	-	-	-	-	x	x	-	-	x

	Boning	Cutting, trimming	Fat standardisation	Mixing	Salting	Marinating	Tumbling	Mincing	Emulsification, production of minced meat	Forming	Filling cans and autoclaving	Filling sausages/Stuffing sausages	Breading	Wrapping (in sausage meat)	Baking	LTLT/vacuum heat treatment	Cooking	Deep-frying	Belt-frying	Hot smoking	Cold smoking	Fermentation, maturing	Drying	Cooling after heat treatment	Freezing	Shell freezing	Slicing	Packing, consumer
Pies (pâté en croute, etc.)	x	x	x	x	-	x	-	-	-	x	-	-	-	x	x	-	-	-	-	-	-	-	-	x	x	-	-	x
Other meat preparations	x	x	x	x	-	x	-	-	-	x	-	-	-	-	x	-	x	-	-	-	-	-	-	x	x	-	-	x
Ground meat mixture	x	x	x	x	-	x	-	x	x	x	-	-	-	-	x	-	x	-	-	-	-	-	-	x	-	-	-	x
Breaded products	x	x	x	x	-	-	-	x	x	x	-	-	-	-	x	-	x	x	-	-	-	-	-	x	x	-	-	x
NB: x: process applied. -: process not applied. Source: [220, Clitavi-Avec 2016]																												

10.2.2 Cleaning

Cleaning occurs in three situations at meat processing installations: cleaning during production, cleaning between production batches and cleaning after production [220, Clitravi-Avec 2016].

The meat industry is generally characterised by open production systems and machinery. For this reason, the cleaning is typically manual, applying water and detergents with hoses. Cleaning operators use spray guns but the water pressure must not be too high in order to avoid the formation of aerosols, as this impacts the work environment [17, TWG 2018].

Cleaning during production

This includes cleaning of the production area. It also includes collection of spills on floors to ensure safe working conditions and limit the spread of spills. Hosing with water is applied if needed.

Cleaning between production batches

This includes cleaning of production equipment. It also includes cleaning to remove product remains from the production line before starting a new production batch to ensure 100 % compliance with product specifications. The need for cleaning and the extent of the cleaning are affected by the sensitivity of the following product. Effective planning of the sequence of the individual batches can reduce the need for cleaning between batches but usually does not eliminate the need.

Cleaning after production

This includes cleaning of the production area and equipment after production. Cleaning starts as soon as production ends. The cleaning procedure consists of the following steps:

- Preparation: tidying the area, removing waste, gloves, etc. Ideally, operators remove and collect solid waste before applying water.
- First rinse: the area and machines are hosed down in order to take meat waste to the floor and collect this before it goes to the waste water. The purpose is also to pre-soak surfaces.
- Application of detergent: operators apply a premixed mixture of detergent and water, forming a foam which clings to surfaces. The detergent should be allowed to work for 15–20 minutes. Most often, the pH of the cleaning solution is alkaline, changing to acid once a week.
- Rinsing: operators hose down the area with water to remove foam.
- Disinfecting: a disinfectant is applied on the equipment. Most often, a liquid solution containing chloride is used.
- Final rinse: water is applied to remove the disinfectant.

10.2.3 Thawing processes

Thawing at ambient temperatures is slow compared to using water or hot air. The latter may cause a rapid growth of microorganisms on the surface layers of the thawed product and hinder reabsorption of thawed water. This creates the unsightly and often nutritionally wasteful drip loss. The use of microwave energy, which is not transferred by conduction through the thawed food layers, is a faster and less damaging thawing process.

Traditional thawing takes place under running water. In this case, the unpacked raw materials are completely immersed in pools of water. They can also be thawed with air at controlled temperatures. Thawing by sprinkling is also applied. Desalting and thawing are carried out simultaneously.

10.3 Current consumption and emission levels

10.3.1 General information

Table 10.3 shows the potential environmental effects of the typical processes applied in meat processing installations.

Table 10.3: Potential environmental effects of typical processes applied in meat processing installations

Process	Potential environmental effects
Boning	Energy consumption for cooling of production facilities (room temperature 5–10 °C).
Cutting, trimming	Energy consumption for cooling of production facilities (room temperature 5–10 °C).
Fat standardisation	Energy consumption for cooling of production facilities (room temperature 5–10 °C).
Mixing	Energy consumption for cooling of production facilities (room temperature 5–10 °C). Product loss to waste water caused by difficulties of emptying the equipment before cleaning/shift of production batch.
Salting, dry salting, vessel salting, injection	Energy consumption for cooling of production facilities (room temperature 5–10 °C). Waste water containing brine/salt and meat juice.
Marinating	Energy consumption for cooling of production facilities (room temperature 5–10 °C). Waste water containing marinade and meat juice.
Adding additives, preservatives, flavour and enzymes.	Waste water production containing, for example, phosphates or enzymes or other substances.
Tumbling	Energy consumption for cooling of production facilities (room temperature 5–10 °C). Waste water containing brine/salt and meat juice.
Mincing	Energy consumption for cooling of production facilities (room temperature 5–10 °C). Product loss to waste water caused by difficulties of emptying the equipment before cleaning/shift of production batch.
Emulsification, production of minced meat	Energy consumption for cooling of production facilities (room temperature 5–10 °C). Product loss to waste water caused by difficulties of emptying the equipment before cleaning/shift of production batch.
Forming	Water to lubricate the moulds. Waste water containing product residues.
Filling cans and autoclaving	Water consumption for cleaning of cans prior to filling, washing of filled cans, autoclaving and cooling of finished products. Waste water containing product residues and chemicals added to the water to prevent deposition of calcium and the formation of rust on the cans. Energy for autoclaving and cooling of products.
Filling sausages/ Stuffing sausages	Energy consumption for cooling of production facilities (room temperature 5–10 °C). Product loss to waste water caused by difficulties of emptying the equipment before cleaning/shift of production batch.
Breading	Product loss of breading material (batter) to waste water.
Wrapping	Energy consumption for cooling of production facilities (room temperature 5–10 °C). Product loss to waste water caused by difficulties of emptying the equipment and handling of the sausage meat before cleaning/shift of production batch.
Baking	Energy consumption for heating and cooling.

Process	Potential environmental effects
LTLT/sous vide heat treatment	Energy consumption for heating and cooling. Water consumption for filling the heating and cooling vats.
Cooking	Energy consumption for heating. Water consumption for filling of the cooking vat, or water for production of steam for the cooking in cooking cabinets. Waste water containing product residues from the processed product.
Deep-fry	Energy consumption for heating of the oil. Water consumption for cleaning the conveyor belt during production. Waste water containing oil and residues from the processed products. Used oil (and sediments from reused oil). Emission of odour.
Belt-frying	Energy consumption for heating. Water consumption for cleaning the conveyor belt during production. Waste water containing residues from the processed products. Emission of odour.
Hot smoking	Emission of smoke and odour. Waste water from cleaning smoking chambers containing condensed smoke.
Cold smoking	Emission of smoke and odour. Waste water from cleaning smoking chambers containing residues from the smoke.
Fermentation, maturing	Energy consumption for conditioning of air (temperature and humidity) in fermentation/climate chambers.
Drying	Energy consumption for conditioning of air (temperature and humidity) in climate chambers.
Cooling after heat treatment	Depending on the chosen process, consumption of energy. Water consumption if water is used in the cooling process. Waste water containing organic matter from the processed product – if water is used.
Freezing	Depending on the chosen process, consumption of energy or/and cryogenic gases.
Shell freezing	Depending on the chosen process, consumption of energy or/and cryogenic gases.
Slicing	Product loss to waste water during cleaning.
Packing, consumer	Cardboard, plastic and food waste from production error.
Bulk packing	-
<i>Source:</i> [17, TWG 2018] [220, Clitravi-Avec 2016]	

10.3.1.1 Energy consumption

A considerable amount of thermal energy is used in processes involving heat treatments such as boiling, cooking, pasteurising, sterilising, drying and smoking. Other large energy-consuming operations are chilling, freezing, thawing, and cleaning and disinfection.

Figure 10.2 shows data for specific energy consumption (MWh/tonne of raw materials) in various meat processing installations. Data related to raw materials include all types of raw materials used, including for installations producing ready meals and soups.

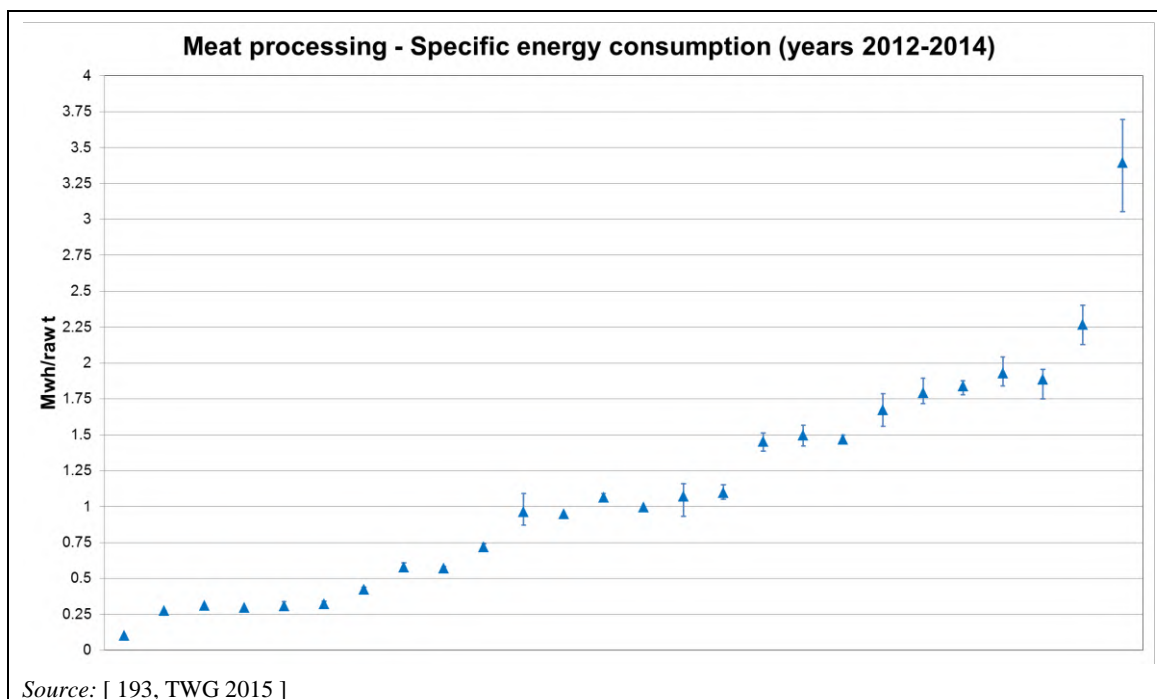

Figure 10.2: Specific energy consumption (MWh/tonne of raw materials) in meat processing

10.3.1.2 Water consumption

The main environmental impact of meat and poultry manufacturing is the production of waste water. Significant quantities of water are used for washing and thawing meat. The reported water consumption is about 3–5 m³/t. The water used for thawing can be recirculated in a closed circuit and used again [94, Germany 2003]. Some other major water-consuming steps include cooking, pasteurising, sterilising, cooling, cleaning and disinfection. Stringent hygiene measures are applied to the cutting and chilling of carcasses which lead to relatively large quantities of waste water arising from equipment and installation cleaning.

Usually, all the water used in the meat product producing sector must be of drinking water quality [119, Clitravi-Avec 2015]. Figure 10.3 shows data for specific water consumption (m³/tonne of raw materials) in various meat processing installations.

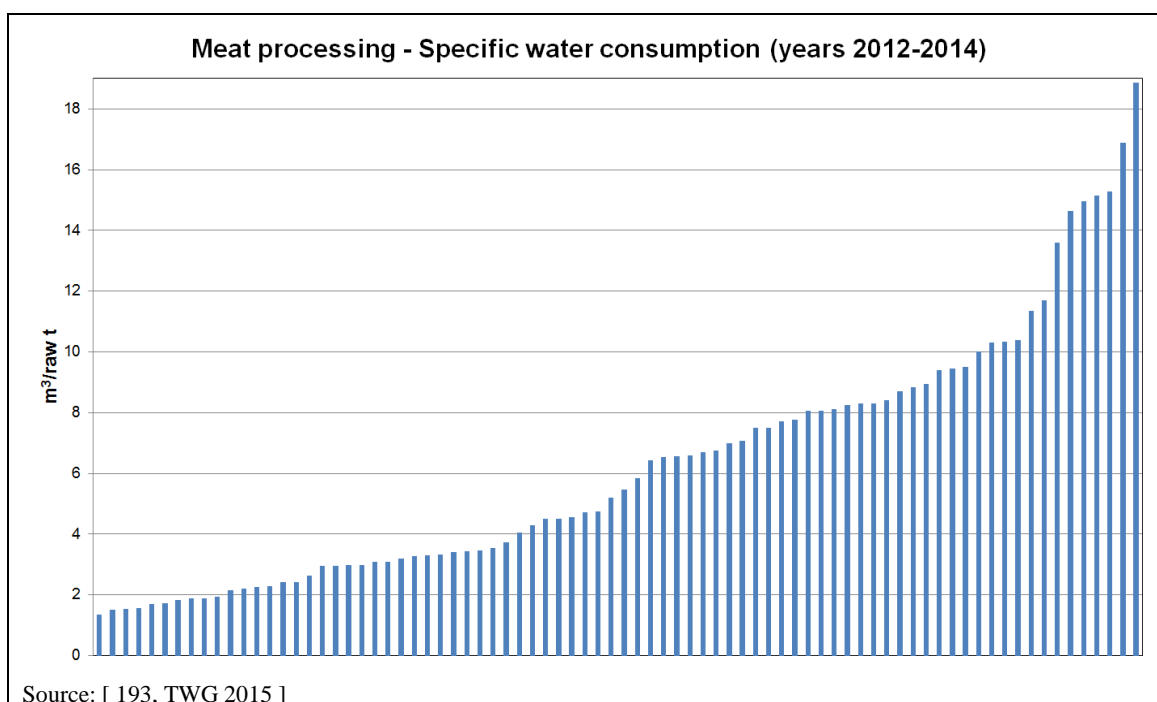

Figure 10.3: Specific water consumption (m³/tonne of raw materials) in meat processing

10.3.1.3 Solid output

Cutting and deboning meat and poultry produces bones, fat and skin. Bones and fat may be used for producing pet food, fur animal feed, glue and detergents for example, or for producing gelatine which can for example be used in some cases in the food and pharmaceutical industries. Some animal by-products are disposed of as waste. Solid output may also be produced in packing operations such as waste packaging [119, Clitravi-Avec 2015].

When mincing meat, mixing, pumping minced meat, filling sausages, etc., a loss of product is unavoidable when changing to a new batch or ending the production [119, Clitravi-Avec 2015]. Alternative methods could be considered (e.g. a suitable kind of slush ice) in order to minimise cleaning water use and product loss.

10.3.1.4 Emissions to water

Figure 10.4 shows reported data on specific waste water discharges (m³/tonne of raw material) from meat processing installations and all types of discharges.

Some installations apply direct cooling of products with water and, thus, can generate high volumes of waste water. Installations producing ready meals and soups apply some processes related to vegetable processing (that differ from sites that exclusively transform meat) and associated with a significant water consumption, mainly soaking (for dried vegetables) and blanching. These specific processes contribute to add more than 2 m³ of waste water discharge per tonne of raw materials. In addition, for installations that make canned products there is also a cooling step after sterilisation that contributes to the water discharge too. Due to the variety of ingredients (additives, preservatives, flavour and enzymes) and number of steps, a lot of cleaning is necessary [98, TWG 2017].

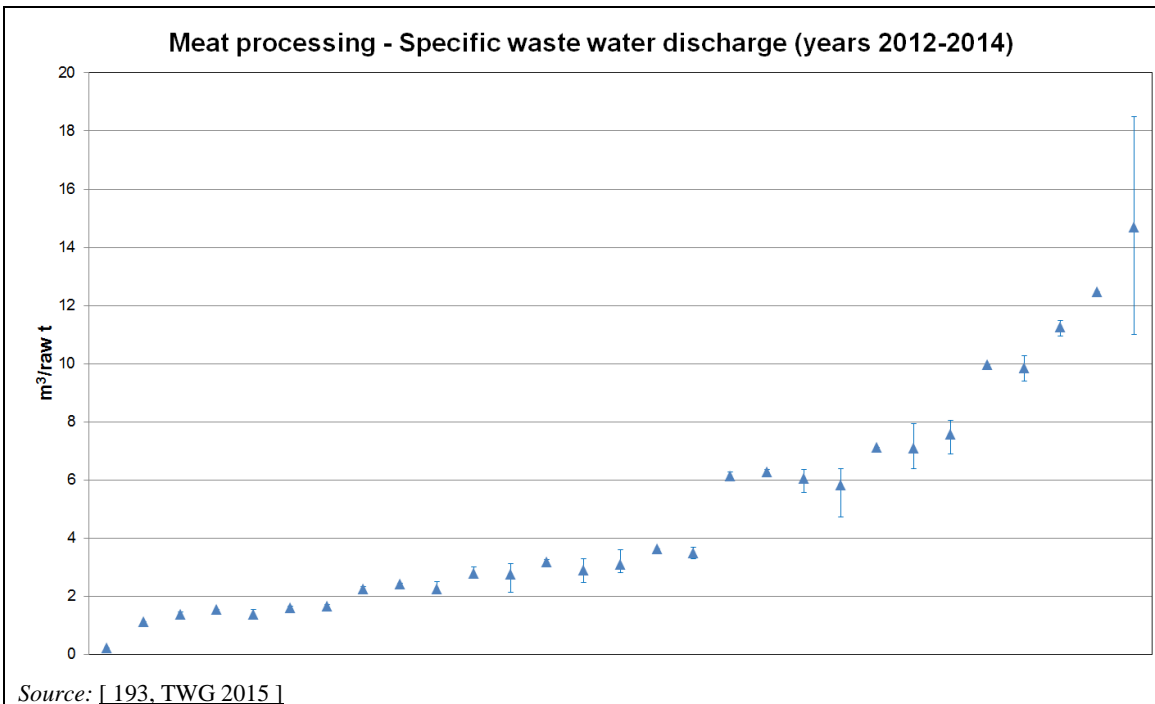

Figure 10.4: Specific waste water discharge (m³/tonne of raw materials) in meat processing for all types of discharges

The Danish Meat Research Institute has analysed whether specific processing processes in individual installations can explain differences in production-specific waste water data. Data were collected from 14 anonymous installations for three years. The analysis is performed only on yearly averages. Eight processes were selected, based on the fact that more than 50 % of the installations informed that these processes were in use in their installation (see Figure 10.5 and Figure 10.6) [85, Clitravi 2017].

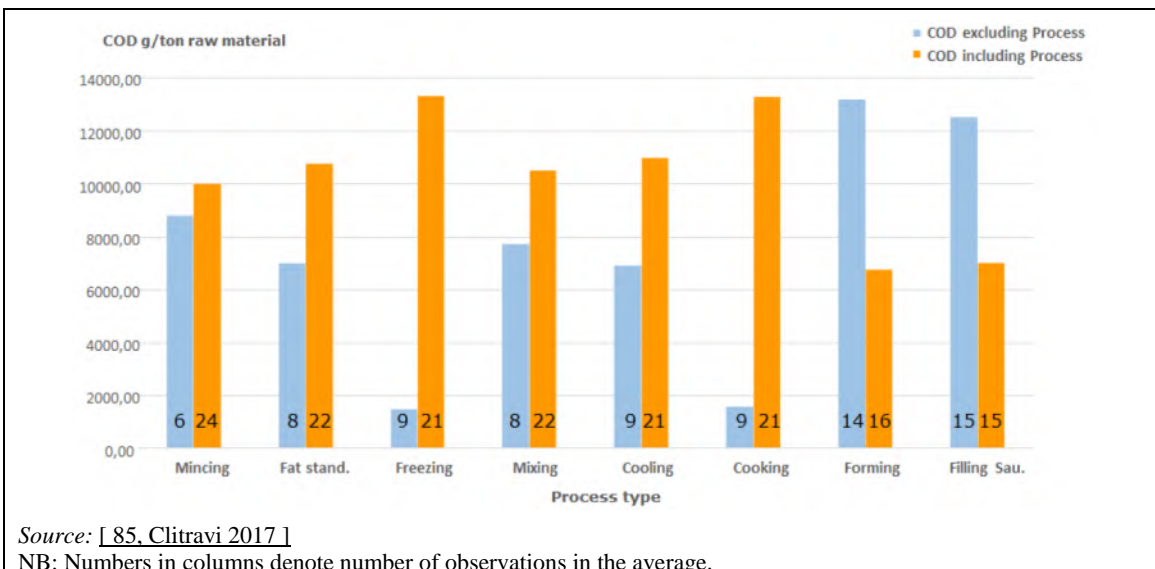

Figure 10.5: Difference in COD specific loads between meat installations including and excluding selected processes

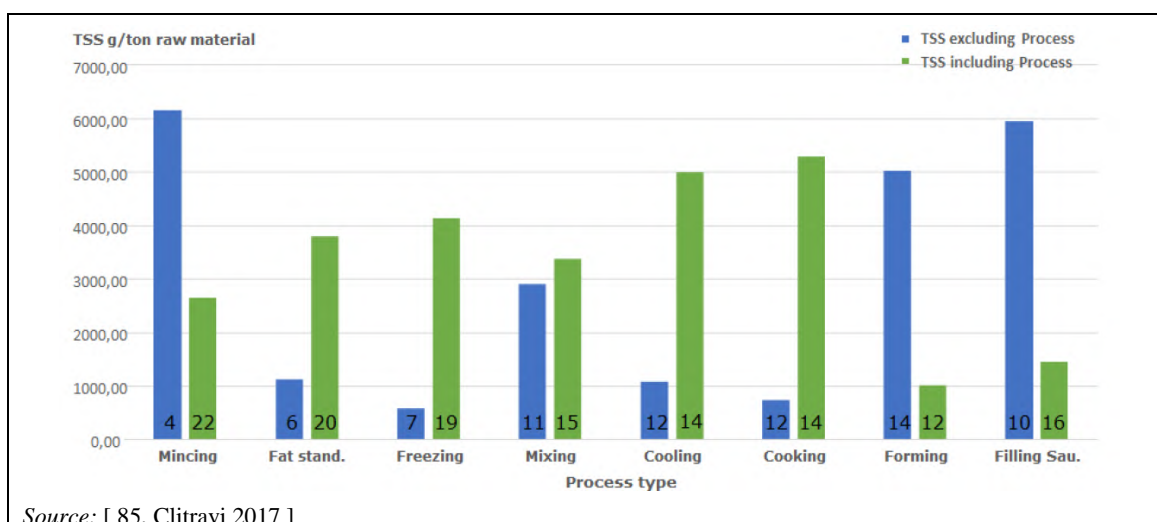

Figure 10.6: Difference in TSS specific loads between meat installations including and excluding selected processes

In general, installations where cooking and/or freezing is performed have higher COD values than installations that are not using these processes. At some level, this also applies to other processes such as cooling and mincing. Similarly, installations using processes such as freezing, cooling and/or cooking have a higher TSS level, while processes such as forming and filling sausages do not generate quite such a high level of TSS.

More information on emissions to water can be found in Section 2.2.3.

10.3.1.5 Emissions to air

Air pollution is produced mainly due to the operation of boilers and smoking chambers. Odour may be a nuisance. Refrigerants may leak, causing air pollution.

10.3.2 Meat and poultry production

10.3.2.1 General information

This category covers a wide range of products and processing techniques, which it is not practicable to consider individually.

All lines, equipment and process areas that are not in designated dry areas require wet cleaning, which generates waste water contaminated with the product, raw materials and cleaning chemicals. If scraps are washed down the drain, this will increase the COD, fat and TSS content of the waste water. Cooking methods that involve direct contact between water or steam and product produce waste water, as do cooling, chilling, freezing and filling operations.

Ingredients added to the meat may enter the waste water stream as a result of equipment washouts and spillage. Those used in large quantities, e.g. batter, breadcrumbs and cooking oil, can make a significant contribution to the BOD, TSS and FOG levels in the waste water.

It is reported that, in the UK, fresh meats, especially poorer-quality beef, are often treated with enzymes of plant or fungal origin to improve tenderness. The meat is either dipped in or sprayed with enzymes in solution. Enzymes are complex organic structures and, unless operators ensure that the discharge of the enzyme solutions is kept to a minimum, they will carry a BOD contribution and may potentially affect the biology of a WWTP [8, Environment Agency of England and Wales 2000]. Italy reports that the technique is not used there [96, Italy 2003].

10.3.2.2 Salami and sausage production

The main environmental factors relating to sausage manufacture concern the smoking and cooling processes. Wood smoke contains many compounds, which are of concern from a health point of view. They include PAHs, phenols, nitrite and N-nitroso compounds plus CO. Effective ventilation and exhaust is, therefore, necessary for kilns and rooms.

The smoke can produce odour problems in the surroundings. The odour concentration in the emissions from a smoking kiln depends on the smoking process and the ventilation and drying conditions. A typical odour concentration in untreated air is 5 000–20 000 OU_E/m^3 . A wet scrubber for cleaning the emissions from a smoking kiln will typically have an efficiency of 50–70 %, measured in OU_E/m^3 .

A carbon content of 1 000 ppm has been measured in the exhaust from a modern warm smoking and cooking unit. After thermal oxidation at 815 °C and cooling to 26 °C, 5 ppm carbon was measured.

Only very limited information is available about the use of resources and pollution from the manufacturing of salami and Vienna sausages. One reason is that a meat processing installation or a slaughterhouse may have many other activities besides those mentioned here and that the companies do not have separate figures for consumption or emission levels for each product line.

10.3.2.3 Freezing

The only waste water generated from freezing is the overflow from the cooling system and freezer defrost water.

10.3.2.4 Curing

Salting and curing can introduce NaCl and Na_2NO_3 into the waste water. Operators need to minimise overproduction of brine and also production of off-specification brine. Not only would this constitute discharge of raw material, but excess/waste brine that would also have a detrimental effect on the WWTP if discharged in large quantities. Chloride brine is not reduced through a biological WWTP, apart from dilution. Traditional dry curing is practised by a number of small highly specialised companies. The process liberates small quantities of cooking waste water only.

10.3.2.5 Smoking

Smoking is most often carried out on cured meat; however, it can be used on fresh meat products that are cooked before serving. Hot smoking typically lasts for a few hours and cold smoking for several days. In general, the different smoking technologies can be summarised as follows:

- smoking food with combustion smoke (conventional smoke);
- smoking food with friction smoke (conventional smoke);
- smoking food with purified smoke.

During the application of smoke to the meat products, a portion of the smoking ingredients condenses on the walls of the chambers. These tar-like layers are removed with hot water by an alkaline cleaning solution. This water may be highly contaminated and should be disposed of separately.

More general information about the smoking process can be found in Section 7.2.3.3.

10.3.2.5.1 TVOC emissions to air from smoke kilns

Reported TVOC emission data are presented in Table 10.4.

Table 10.4: Reported TVOC emission data from smoke kilns (spot samples, concentrations)

Installation ID-point of release	TVOC ⁽¹⁾ (mg/Nm ³)	Frequency of monitoring	Monitoring standard	Sampling duration (h)	Abatement technique
331-1	0.10	Yearly	EN 12619	1.00	Carbon adsorption
102-1	< 7.70	Monitored between 2 and 4 years	VDI-3481	0.75	Thermal oxidation of waste gases
102-2					
102-4					
102-5					
102-3	8.70				
⁽¹⁾ = no information provided about % O ₂ levels. Source: [193, TWG 2015]					

More data on TVOC emissions to air from smoke kilns are presented in Section 10.4.3.1.

10.3.2.6 Drying

Dried meats are produced by curing, followed by drying at low humidity. Unless odour abatement considerations make it necessary to condense water vapour from the dryer hot gases, no waste water is generated.

10.3.2.7 Canning

The use of hot water or direct steam heating for cooking prior to canning produces waste water contaminated with fat, protein and fragments of meat. After canning, the meats are heat-processed to achieve pasteurisation and increase their shelf life. Can cleaning, both before and after filling, and can cooling use considerable quantities of water.

10.4 Techniques to consider in the determination of BAT

10.4.1 Techniques to reduce water consumption

10.4.1.1 Techniques related to cleaning

10.4.1.1.1 Dry cleaning

This technique is described in Section 2.3.3.2.1.

Technical description

Reported examples of where the technique is applied are as follows:

- When ground meat residues, particularly meat mix for salami production or from sausage-making, from equipment such as bowl choppers and sausage fillers, and from floors, are left standing, they stick to the surfaces and make subsequent cleaning difficult. Cleaning such equipment immediately after the end of production minimises the cleaning efforts and the need for water and detergents. The ground meat residues are manually removed to the maximum practical extent, prior to cleaning and sending for rendering.
- Applying dry cleaning of meat scraps during trimming and cutting operations to reduce the waste water pollutant load.
- Drain covers with adequate hole diameters are fitted to stop meat scraps entering the WWTP.

Technical considerations relevant to applicability

Applicable to meat manufacturing installations.

Reference literature

[[20, Nordic Council of Ministers 2001](#)]

10.4.1.1.2 Minimisation of the production and use of flake ice

Description

By using a suitable mixture of chilled and frozen raw materials, the production and use of flake ice can be minimised.

Technical description

When processing ground frozen meat, flake ice is often used to cool the meat mixture. By using a suitable mixture of chilled and frozen raw materials, it is possible to avoid the use, and therefore the production, of flake ice. Sometimes flake ice is added when processes such as chopping make the temperature of the meat rise, thus causing a risk to the hygiene or the quality of the product, or if only a small amount of water needs to be added to the product.

Depending on the raw materials used, there can be a need to apply flake ice in order to keep the temperature low during the chopping of meat, e.g. if the raw materials are not frozen. However, if the temperature is suitably controlled by using frozen raw materials this can be sufficient (e.g. commonly done in Denmark), but otherwise flake ice is an option to keep the desired low temperature if a specific amount of water is desired in the recipe.

The production of flake ice can indeed be reduced if frozen meat can be used in the process. But in many cases it is not possible to mix frozen meat with chilled meat. The possibility of mixing chilled meat with frozen meat depends on the logistics, planning and storage capacity at the factory. It is necessary to have a tempering room (cooling room) where the cooling engine can both cool and heat the room. If too many blocks of frozen meat are placed in the room the temperature will drop too low for the meat to defrost.

Achieved environmental benefits

Reduced water and energy consumption.

Environmental performance and operational data

No information provided.

Cross-media effects

No information provided.

Technical considerations relevant to applicability

Applicable in ground frozen meat processing installations.

Economics

No information provided.

Driving force for implementation

Reduced costs associated to reduced energy consumption.

Example plants

No information provided.

Reference literature

[20, Nordic Council of Ministers 2001]

10.4.2 Techniques to reduce waste

10.4.2.1 Separation of residues

This technique is described in Section 2.3.5.3.

There are likely to be many other opportunities to apply this technique within the sector.

- Apply dry collection of all solid wastes by means of trays or baskets to prevent them from falling on the floor and entering the WWTP.
- Many raw materials are received or transported/stored in open vats or trolleys. A quantity of meat juice collects in the bottom of such containers. Rather than emptying this juice into the WWTP and therefore increasing the pollution of the waste water, it is used in the manufacture of processed meat products.
- Cutting and deboning operations usually take place after chilling. After chilling, the carcasses are more easily handled, cut and deboned. The bones are separated from the meat and together with meat scraps and fats, not intended for human consumption, are collected in trays fixed to the equipment and sent for treatment or disposal at animal by-products installations.

Technical considerations relevant to applicability

Applicable to meat manufacturing installations.

Reference literature

[20, Nordic Council of Ministers 2001]

10.4.3 Techniques to reduce emissions to air

10.4.3.1 Techniques to reduce TVOC emissions from smoke kilns

10.4.3.1.1 Adsorption

General information on the technique is given in Section 2.3.7.3.3.

Environmental performance and operational data

Adsorption has been applied for the abatement of TVOC emissions from a smoke kiln in installation #331. A TVOC concentration of 0.1 mg/Nm³ was achieved (one measurement in 2014). The monitoring standard used was EN 12619. The 2013 measurement value was 3.1 mg/Nm³.

Reference literature

[193, TWG 2015]

10.4.3.1.2 Thermal oxidation of waste gases

General information on the technique is given in Section 2.3.7.3.6.

Environmental performance and operational data

Table 10.5 shows installation-specific performance data related to the application of thermal oxidation for abating TVOC emissions to air from a smoke kiln.

Table 10.5: Average values of periodic measurements of TVOC emissions to air from a smoke kiln after thermal oxidation

Installation ID-point of release	TVOC (mg/Nm ³)	Monitoring standard	Additional information
102-1	< 7.70	VDI-3481	Mainly bacon and sausages production Smoke from smouldering wood
102-2			
102-4			
102-5			
102-3	8.70		Mainly bacon smoke from smouldering wood
<i>Source:</i> [193, TWG 2015]			

More detail for the above emission points:

102-1

The emission point is the exhaust of a thermal oxidising unit after a smoking chamber producing bacon.

Measured values in three half-hourly measurements were very low (< 1 mg/Nm³). The uncertainty of the measurement method was added to the value, resulting in the given value of < 7.7 mg/Nm³ in the questionnaire.

O₂ values: 16.7 %, 15.1 % and 15 %.

Temperature of the thermal oxidising unit: between 850 °C and 950 °C.

102-2

The emission point is the exhaust of a thermal oxidising unit after a smoking chamber producing bacon.

Measured values in three half-hourly measurements were very low (twice $< 1 \text{ mg/Nm}^3$ and once 1 mg/Nm^3). The uncertainty of the measurement method was added to the value, resulting in the reported value of $< 7.7 \text{ mg/Nm}^3$.

O₂ values: 15.7 %, 15.6 % and 14.5 %

Temperature of the thermal oxidising unit: between 827 °C and 848 °C.

102-3

The emission point is the exhaust of a thermal oxidising unit after a smoking chamber producing bacon.

Measured values in three half-hourly measurements were very low (twice $< 1 \text{ mg/Nm}^3$ and once 2 mg/Nm^3). The uncertainty of the measurement method was added to the value, resulting in the reported value of 8.7 mg/Nm^3 .

O₂ values: 19.0 %, 15.8 % and 15.5 %

Temperature of the thermal oxidising unit: between 892 °C and 899 °C.

102-4

The emission point is the exhaust of a thermal oxidising unit treating the waste gas of three smoking chambers producing bacon.

Measured values in three half-hourly measurements were very low (e.g. $< 1 \text{ mg/Nm}^3$). The uncertainty of the measurement method was added to the value, resulting in the reported value of $< 7.7 \text{ mg/Nm}^3$.

O₂ values: 15.9 %, 15.7 % and 16.0 %

Temperature of the thermal oxidising unit: between 827 °C and 848 °C.

102-5

The emission point is the exhaust of a thermal oxidising unit treating the waste gas of 12 smoking and cooking chambers producing various types of sausages.

Measured values in three half-hourly measurements were very low (e.g. $< 1 \text{ mg/Nm}^3$). The uncertainty of the measurement method was added to the value, resulting in the reported value of $< 7.7 \text{ mg/Nm}^3$.

O₂ values: 15.9 %, 15.7 % and 15.6 %

Target temperature in the thermal oxidising unit: 750 °C.

Additional data (2017 measurements) from a German installation (that did not participate in the data collection) are presented in Table 10.6. Measurements were performed with the FID-method.

Table 10.6: Additional data of periodic measurements of TVOC emissions to air from a smoke kiln after thermal oxidation

ID	TVOC (mg/Nm ³)	CO (g/Nm ³)	Smoking method	Products	Additional information
DE-SmK-04	1) 30 2) 30 3) 32 4) 29 5) 29	1) 0.79 2) 0.80 3) 0.78 4) 0.80 5) 0.80	- Smouldering of woodchips - 9 smoking chambers with 1 smoke generator for each one - One thermal oxidiser for all 9 chambers	Sausages	-10 minute averages - Thermal oxidiser temperature set to 600 °C - Raw gas: TOC 880 mg/Nm ³ , 790 mg/Nm ³ , CO 3 900 mg/Nm ³ , 2 800 mg/Nm ³ (two measurements of each parameter)
Source: [60, Germany 2017]					

In a Norwegian investigation of sausage smoking, when examining a cooking/smoking cabinet, the following emissions were found after the thermal oxidation of the smoke gases: 7 mg TOC/Nm³ or 0.2 mg TOC/t of sausages. The gas did not contain CO [20, Nordic Council of Ministers 2001].

Thermal oxidation is efficient, but it comes at a cost of high energy consumption; up to 300 times higher than combined filter methods. Especially starting up thermal oxidation is expensive, implying that it is more suited for continuous smoking [2, IED Forum 2018].

Reference literature

[2, IED Forum 2018], [20, Nordic Council of Ministers 2001], [60, Germany 2017], [193, TWG 2015]

10.4.3.1.3 Wet scrubber and electrostatic precipitator

General information on wet scrubbers is given in Section 2.3.7.3.1. An electrostatic precipitator is commonly used as a pretreatment step.

Environmental performance and operational data

Data from a German installation (that did not participate in the data collection) are presented in Table 10.7.

In all the cases an alkaline scrubbing solution was used. Before scrubbing, air emissions were treated in an electrostatic precipitator for emissions of tar and aerosols abatement. Smouldering of woodchips was used as the smoking method.

In more detail, the smoke coming from the smoke chamber is first passed through a cooler to chill the smoke and condense substances with a low vapour pressure. Then the smoke passes a tubular electric filter. A corona discharge charges particles and droplets (tar and water) under a high voltage of 13 kV. The electric field pushes the charged particles towards the wall. The tar and water mixture runs down the filter wall and is separated to a bung-hole barrel. Then the tar can be disposed of separately.

The air flow is then led into the gas scrubber. The scrubber is built as a counter-flow scrubber. In the scrubber, the acidic, water-soluble gas component parts are washed and neutralised by alkaline wash water. The dosage of sodium hydroxide solution is done via a pH control. There is a high dose to a pH value of about 10.5. Due to the acidic flue-gas the pH value falls below the lower setpoint value of 8.5. Upon reaching the lower set value, a part of the washing water is discharged in order to prevent salting of the scrubber water. After that, first fresh water is automatically added and then caustic soda to again reach to the upper setpoint, pH 10.5. The scrubber is equipped with a foam control which adds defoamer as required and therefore ensures

uniform suction. A drop separator in the outlet of the scrubber captures the aerosols from the washing process, before the cleaned exhaust gas is fed by a fan into the chimney.

Table 10.7: Data of periodic measurements of TVOC emissions to air from a smoke kiln after wet scrubbing

ID	TVOC (mg/Nm ³)	TVOC (kg/h)	Products	Additional information
SmK-05 (2011 data)	Silica gel method: 1) 50.3 2) 31.9 3) 18.1 FID-method: 1) 79 2) 107 3) 101 4) 67 5) 55	Silica gel method: 1) 0.074 2) 0.047 3) 0.027	Sausages and cold meat	Half-hourly averages; 3 chambers with 2 trolleys & 2 chambers with 8 trolleys; all five chambers connected to the abatement unit
SmK-06 (2014 data)	Silica gel method: 1) 29.6 2) 42.8 3) 96.2	Silica gel method: 1) 0.037 2) 0.053 3) 0.120	Red sausage	Half-hourly averages; 2 chambers with 2 trolleys for cold smoking; 2 chambers with 2 trolleys for hot smoking
DE-SmK-08 (2013 data)	Silica gel method: 1) 37.7 2) 30.4 3) 35.2 FID-method: 1) 106.8 2) 98.9 3) 93.5	Silica gel method: 1) 0.094 2) 0.076 3) 0.088 FID-method: 1) 0.262 2) 0.243 3) 0.230	Sausages, cold meat, bacon	Half-hourly averages; 11 chambers with 3 trolleys for cold smoking; 3 chambers with 2 trolleys for hot smoking
SmK-09 (2013 data)	Silica gel method: 1) 35.4 2) 19.6 3) 31.2 FID-method: 1) 72 2) 82 3) 87 4) 84	Silica gel method: 1) 0.057 2) 0.032 3) 0.050	Bacon, pork	Half-hourly averages; 4 chambers with 6 to 12 trolleys
SmK-10 (2017 data)	Silica gel method: 1) 8.9 2) 6.0 3) 6.2 FID-method: 1) 47.7 2) 41.4 3) 28.1 4) 10.3	Silica gel method: 1) 0.030 2) 0.021 3) 0.021	Bacon, pork	Half-hourly averages; 17 chambers with 4 trolleys, hot and cold smoking

Source: [60, Germany 2017]

The combined techniques have a slightly higher TVOC emission than thermal oxidation, but energy use is between 150 and 300 times lower [2, IED Forum 2018].

Reference literature

[2, IED Forum 2018], [60, Germany 2017]

10.4.3.1.4 Use of purified smoke

See also Section 7.4.3.1.1.

Description

Smoke generated from purified primary smoke condensates is used to smoke the product in a smoke chamber.

Technical description

The fully automated purified smoke generators have different designs, depending on their intended use (cold, warm and/or hot smoking). They all consist of a pneumatic and electrical stainless steel cabinet.

Smoking systems are equipped with a special smoke generator. The smoking system's computer control manages the entire smoking process. The process time, temperature, relative humidity and circulation speed are controlled. The smoke density is set on the smoke generator and aligned with the respective process (cold smoke, warm smoke, hot smoke) and the smoking system size (air volume) and smoking system feed (quantity of food to be smoked) [[32, CleanSmoke 2018](#)].

Achieved environmental benefits

Low emissions to air. Reduced water consumption.

Environmental performance and operational data

By applying purified smoke, two German meat installations (one producing salami and the other various smoked products) have reported achieving almost zero TVOC emissions to air (one spot measurement in each installation).

Moreover, the application of purified smoke in four smokehouses at a German installation has generated the following environmental benefits:

Burning or smouldering wood produces a number of substances, which have a negative impact on the environment. Combustion smoke consists of approximately 25 % gas, 27 % water vapour, 32 % charcoal (ashes) and 16 % tar. The purified smoke is nearly free of undesired substances such as tar and ashes. It results from the in-between step after generating the smoke and before applying it to the smoking goods. This, and the fact that smoke is freshly generated using compressed air, is the main reason why the purified smoke process has proven to have the lowest environmental impact on the water consumption, carbon footprint and emission levels of the waste water in comparison to the smouldering smoking methods. It also significantly reduced the use of natural resources such as wood for generating smoke.

By smoking with purified smoke, the waste water consumption has been reduced by 88 % in comparison to the smouldering smoking method. At the same time, the use of cleaning detergents (e.g. strong alkaline products) for cleaning of the smoke generators and the smokehouses has also been reduced by 68 % and, therefore, only a limited amount ends up in the waste water.

The reason for the saving is that the smoke generated with the purified smoke process does not contain tar and ashes. Hence, the cleaning of the purified smoke required less efforts and water compared to the combustion smoke generator. In addition, it is important to mention that, in the same way the emission levels of the waste water, such as COD, BOD₅ and phenols, have also been significantly reduced by approximately 95 %.

It has also been proven that smoking with purified smoke has reduced the waste production of tar and ashes by almost 100 % in comparison with the smouldering smoking method. That means for the environment that no tar and ashes are created or emitted to the environment.

The same significant result has been proven for the carbon footprint. Based on the calculation of the entire production process including the shipping chain, the CO₂ emission has been reduced by 83 % compared to the smouldering smoking technology. Furthermore, as no woodchips or sawdust are burned in order to generate smoke, the purified smoke process enables the manufacturer to smoke in a closed loop. Therefore, no exhaust emissions (dust, CO, NO_x) are being produced. This in turn means that manufactures do not have to operate an afterburner in order to fulfil the legal requirements for the exhaust emissions. This results in a significant energy and cost saving for the manufacturer.

Cross-media effects

No information provided.

Technical considerations relevant to applicability

Applicable in the processing of meat, fish and seafood products, cheese, as well as fruit and vegetables.

Economics

A total cost of EUR 68 000 has been reported for the installation of purified smoke generation at four smokehouses with a capacity of 1 872 tonnes per year.

Driving force for implementation

Reduction of tar content in the smoked product.

Example plants

Meat processing plants in Germany.

Reference literature

[32, CleanSmoke 2018], [60, Germany 2017]

10.4.3.2 Techniques to reduce odour**10.4.3.2.1 Recirculation and burning of exhaust gases from frying****Description**

Recirculation and burning of exhaust gases from frying.

Technical description

Emissions to air are dependent on the operational temperature of frying, e.g. high-temperature frying at 180–200 °C will result in more rapid production of oil breakdown products than frying at lower temperatures. The air above a fryer is extracted and vented. This exhaust air contains VOCs and may lead to odour complaints. Oil and heat recovery and recirculation of exhaust gases to the burner minimises these emissions.

Achieved environmental benefits

Reduced emissions to air, including odour. Recovery of oil. Recovery of energy. Recycling of exhaust gases.

Environmental performance and operational data

For example, when controlling a crisp-frying process, ensuring that the frying process ends when the final moisture content is in the critical range of 1–2 % leads to a minimisation of emissions to air. Furthermore, to save energy, the heat exchangers are mounted in the fryer exhaust hood.

Figure 10.7 illustrates a heat and oil recovery system applied to a fryer.

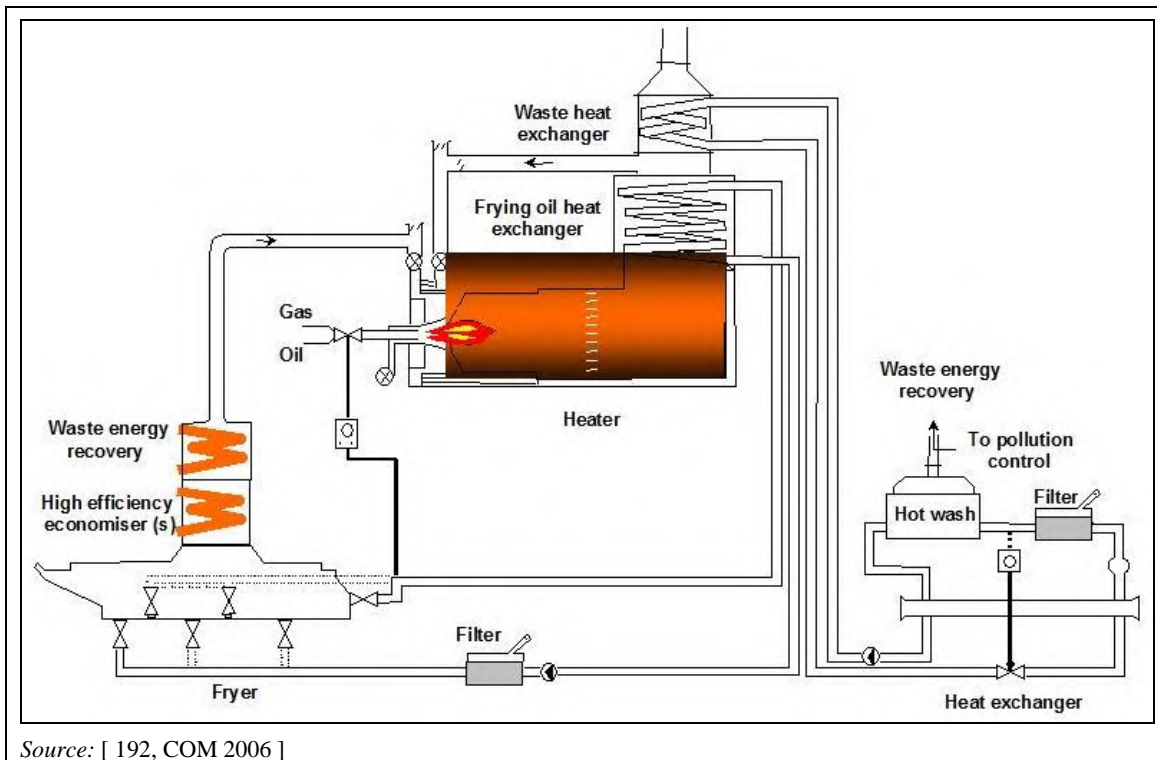

Figure 10.7: Heat and oil recovery with heat exchangers mounted in the fryer exhaust hood

Cross-media effects

No information provided.

Technical considerations relevant to applicability

Applicable in the meat and poultry and potato frying sectors.

Economics

No information provided.

Driving force for implementation

To prevent complaints about odours and to meet legal requirements.

Example plants

No information provided.

Reference literature

[49, Environment Agency of England and Wales 2000], [192, COM 2006]

11 OILSEED PROCESSING AND VEGETABLE OIL REFINING

11.1 General information about the sector

In the EU, 47 million tonnes of oilseeds are crushed annually. This results in the production of 17 million tonnes of crude oils and 29.5 million tonnes of meals. The EU annual consumption of oilseed meals is around 52 million tonnes. The EU imports 24 million tonnes of meals annually, meaning almost half of the EU meal consumption is imported [213, FEDIOL 2015].

Key environmental aspects of oilseed crushing and vegetable oil refining are the consumption of water, steam, electricity, hexane, bleaching earth and chemicals (acids, caustic soda) and emissions to air (VOCs, H₂S, CO₂) and to water [213, FEDIOL 2015].

11.1.1 Oilseed processing

Oilseed processing (or crushing) is the processing of oleaginous seeds, such as rape, soya or sunflower, for the production of crude vegetable oils and protein-rich meals. Crude oils generally need further processing (refining) to render them suitable for consumption. The protein-rich meals are used for animal feeding.

The EU has around 50 oil mills (oilseed crushing facilities) that fall under the scope of the FDM BREF (reference year 2015). Some 20 of these are stand-alone oil mills of which the crude oil produced is sold and/or processed elsewhere. The other mills are integrated crushing and refining installations where the crude oil resulting from the oilseed crushing is refined at the same installation. Some 10 oil mills process only soybeans, around 35 only soft seed (rapeseeds and/or sunflower seeds) and some 5 can process both soybeans and soft seeds (also called switch installations). Increasing imports of South American soybean meal in the last decade triggered some EU soybean crushing sites to modify their installation to be able to process both soybeans and soft seeds [213, FEDIOL 2015].

Crushing installations are often located at waterways or in the proximity of harbours to allow bulk delivery of raw materials, whether imported from outside the EU (e.g. soybeans) or from soft seed growing areas in the EU.

11.1.2 Vegetable oil refining

Crude vegetable oils from rapeseeds, soybeans and sunflower seeds, and tropical oils such as palm, palm kernel and coconut oil are refined before being used in food, feed, biofuels, cosmetics, lubricants and other technical applications.

The EU has around 35 refining installations that fall under the scope of the FDM BREF (reference year 2015). Some 20 of these refine the crude oils that they themselves produce from oilseeds in the same installation, the so-called integrated crushing and refining installations. The other 15 are stand-alone refining installations. Three types of stand-alone refineries can be distinguished [213, FEDIOL 2015]:

- Refineries that process tropical oils in bulk. Palm fruits, palm kernels and copra are pressed in tropical countries close to their origin, i.e. in palm and coconut plantations. Crude palm, palm kernel and coconut oil are exported to the EU and refined in bulk tropical oil refineries located in the import harbours.
- Refineries that refine oils and fats of varying botanical origins. These refineries can generally handle crude seed oils as well as tropical oils (multi-oil refining). They are oriented towards batch processing rather than continuous (or bulk) processing.

- Speciality oils and fats refineries process crude and/or refined oils for specific functional or nutritional applications. The processing may include specific refining steps such as hardening, fractionation or interesterification, with the aim of giving the oil physical characteristics needed for the end application.

11.2 Applied processes and techniques

11.2.1 Oilseed processing

The production of crude vegetable oil from oilseeds is a two-step process. The first step involves cleaning followed by preparation of the oilseeds, i.e. drying, dehulling, flaking, conditioning and pressing. Pressing results in crude pressed oil and a cake with an oil content of 12–25 %. Deep expelling reduces the oil content to below 10 %. With deep expelling no subsequent hexane extraction takes place. Soybeans have an oil content of 20 % or less. This low oil content makes pressing superfluous. Soybeans are extracted directly after cleaning and preparation [214, FEDIOL 2015].

The second step entails extraction of the oil from the pressed cake or flaked beans using hexane as a solvent. The extraction takes place in a countercurrent-flow extractor, resulting in two output streams, a mixture of hexane and vegetable oil, called miscella, and a solvent-laden meal. For hexane recovery, the miscella is further processed in a distillation process. For the same reason, the meal is further processed in a countercurrent desolventiser-toaster using indirect and direct steam. Besides removing hexane from the meal, desolventising-toasting also reduces the enzyme activity in the meal. The heat contained in the hexane/steam vapours from desolventising-toasting is reused in the miscella distillation. The meal is dried and cooled by air before being stored in silos or before transport.

11.2.2 Vegetable oil refining

11.2.2.1 Refining of vegetable oils

Refining removes undesirable compounds such as gums, free fatty acids (FFA), pigments, undesirable flavours and odour compounds. In general, there are two ways to refine seed oils, i.e. physical refining and the more conventional chemical refining.

11.2.2.1.1 Chemical refining of vegetable oils

Chemical refining of vegetable oil refers to the following process sequence: degumming/neutralisation, bleaching and deodorisation. ‘Chemical’ in chemical refining refers to the neutralisation step, during which FFA are reduced by the chemical reaction of FFA and a diluted alkali solution (generally sodium hydroxide) to form soap. Soap can be separated from the oil by settling or centrifugation [215, FEDIOL 2015].

Removal of non-hydratable gums and phosphatide acids can be integrated in this process using a preceding acidification step, i.e. using phosphoric acid or citric acid (see description of degumming in Section 11.2.2). The oil is preheated using steam, after which phosphoric acid or citric acid is mixed with it to increase the water solubility of the phosphatides. The aqueous mixture of soap and phosphatides, which is known as soap-stock, is separated from the oil by centrifugation. The oil is mixed with water to wash off the rest of the soaps. Again, the water is removed from the oil by centrifugation. The caustic-refined oil may be dried under vacuum conditions and then pumped to a storage tank. The process is typically operated in a continuous way, as shown in Figure 11.1, but it can also be a semi-continuous or batch process, using long-period mixing and sedimentation equipment.

Then, the soap-stock can be further processed into acid oils by splitting or can be sold to a third party or to an integrated installation. There is also an option to recycle it back into the process. In soap-stock splitting, the fatty acid soaps are reacted with sulphuric acid to reform fatty acids. The process can either be continuous or discontinuous. The reaction medium is heated up to 70–100 °C to increase the speed of the reaction and to improve the separation of the upper oil phase from the lower aqueous phase. Depending on the amount of phosphatides still present in the

crude oil between the aqueous phase and the fatty acids, an intermediate layer of phosphatides can be formed [35, Germany 2002], [75, FEDIOL 2002]. The chemical refining of vegetable oils is shown in Figure 11.1.

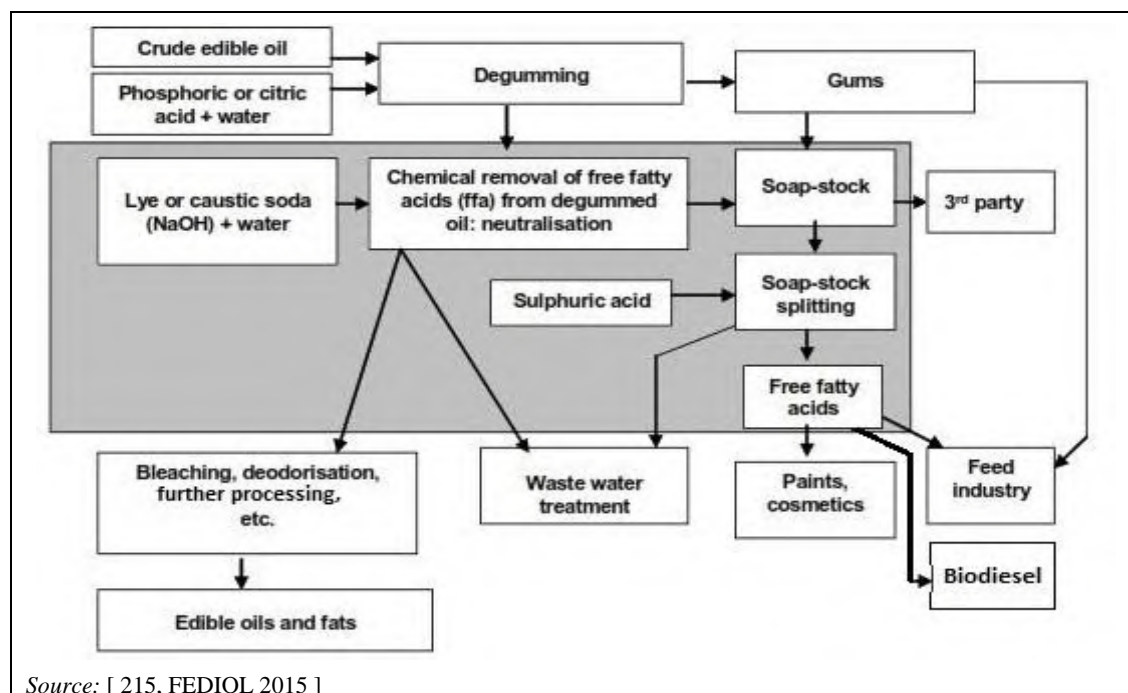

Figure 11.1: Chemical refining of vegetable oils

The centrifuge aqueous discharges, i.e. the soap-stocks, are combined and further treated in a soap-stock splitting system. This acidulation process is used to recover the FFA after treatment with concentrated acid, usually sulphuric acid or occasionally hydrochloric acid, and heating with steam. The separated FFA are then removed in a decanter centrifuge. In integrated installations, the soap-stock can be added to the meal-toasting process. The phosphatides recovered are used as lecithin in human food or in animal feed.

The neutralisation process requires cooling water. The waste water that results from combined neutralisation and soap-stock splitting has a temperature of about 100 °C, high acidity and contains salts of sodium sulphate or sodium chloride and sodium phosphate in high concentrations. If citric acid is used, this increases the BOD load of the waste water. The disposal of process waste water with high concentrations of sulphates (> 2 000 mg/l) into a MWWTP may cause corrosion of the concrete. The phosphorus content of waste water before treatment is high (e.g. between 800 mg/l and 2 500 mg/l as a yearly average) and emission levels may consequently be high [193, TWG 2015]. The waste water may also contain FOG.

Fatty acids are considered a by-product. The treatment of waste water from neutralisation can produce high amounts of sludge, due to the presence of phosphates and/or sulphates. The waste water may have high salt concentrations.

11.2.2.1.2 Physical refining of vegetable oils

Physical refining refers to the following process sequence: bleaching (optionally with acid and/or water pretreatment before addition of the bleaching earth) and deodorisation at high temperature. ‘Physical’ in physical refining refers to the deodorisation step during which the FFA are reduced by physical distillation at high temperature under a deep vacuum [215, FEDIOL 2015].

The oil is mixed under vacuum conditions with 0.1–3 % bleaching earth. This is a clay mineral, such as bentonite or montmorillonite, that has been activated by thermal and/or acidic or other treatments. These earths, sometimes mixed with small amounts of activated carbon, have a very high adsorption capacity. After bleaching for 30 or 90 minutes, the oil is separated from the bleaching earth, using filters. The spent earth contains high amounts of oil, up to 30 %. A steam stripping process can recover a part of the oil or fat. Used bleaching earth can be added to the meal in integrated installations. The bleached oil is further treated in other refinery processes. The equipment used for bleaching consists of mixing vessels, vacuum generators and filters.

The solid output from bleaching is known as spent earth. Due to its high oil content, there is a risk of self-ignition. The spent earth of an oil refinery can be added to the meal formed by crushing to make a by-product. The spent earth used for bleaching hardened oils can also be added to the meal, as long as it does not contain nickel and/or activated carbon. Otherwise, as it has a high calorific value, it is used as an energy source, e.g. in the production of concrete or to produce biogas.

It is possible to remove all the FFA present in the oil in a deodoriser by distillation. A physical pretreatment can be carried out to achieve a low phospholipid content by degumming and using bleaching earth. FFA can then be stripped from the physically pretreated oil, by using steam under vacuum at temperatures of around 250 °C. Previous neutralisation processes can be skipped as neutralisation and deodorisation are combined and are performed in continuously operating single or multistage equipment with integrated heat exchangers and injected stripping steam. This is directly followed by the use of a scrubber to condense the greater part of the fat from the vapours as a water-free product. This is generally carried out, but depends on the raw material and products and on the incoming oil being rich in FFA and low in phospholipids. The scrubber system located after the deodoriser has to remove a much higher amount of FFA than in the case of normal deodorisation [35, Germany 2002], [75, FEDIOL 2002].

11.2.2.1.3 Differences between chemical and physical refining of vegetable oils

The main process differences between chemical and physical refining are as follows [215, FEDIOL 2015]:

- Chemical refining may have the additional combined degumming/neutralisation process. For low volumes, the reaction and settling can be done in a batch vessel. However, most high-volume refineries use a continuous reactor and one to three centrifuges for reaction and separation. The soap separated from the oil can be sold as such (low value) but in most refineries is split by a strong acid (sulphuric acid) in a soap-splitting installation. The products of the soap-splitting installation are a high-quality acid oil (FFA and some entrained oil) and acid water. The acid water normally requires further treatment before discharge to a municipal waste water treatment plant.
- The phospholipids level of oils for physical refining needs to be relatively low to avoid uneconomically high bleaching earth levels in the bleaching step. A diluted acid pretreatment (phosphoric or citric acid) before bleaching-earth dosing enhances the phospholipids- and metals-reducing capacity of bleaching earth. Most extracted seed oils are high in phospholipids and require acid degumming before physical refining. Water degumming alone will likely not sufficiently reduce the level of non-hydratable phospholipids and, if so, may need to be followed by chemical refining. Tropical oils like palm oil, palm kernel oil and coconut oil are sufficiently low in phospholipids to apply physical refining without pre-degumming.
- The stripping of FFA by distillation requires deodorisation temperatures in the range of 170–270 °C. The FFA reduction at lower temperatures is generally insufficient to meet customer specifications. This high temperature may lead to formation of undesirable components like trans fatty acids (especially in highly unsaturated oils like linseed oil and fish oil) and glycidyl ester. It may also reduce the levels of thermo-sensitive minor components like sterols, tocopherols, carotenes, co-enzymes, etc. The deodorisation

temperature in chemical refining can be lower than in physical refining since stripping of FFA is not required. The temperature applied in deodorisation takes into account practical considerations like deodoriser efficiency, heat recovery, product mix, etc.

Comparison of the chemical with physical refining sequences shows chemical refining to have the following disadvantages:

- higher production costs (depreciation, labour, maintenance) due to the additional neutralisation and soap-splitting lines;
- higher oil loss due to entrainment of neutral oil in the soap-stock;
- higher liquid effluent discharge; this effluent is rich in COD, BOD, phosphates and sulphates.

Physical refining is not possible at all refineries because of the type of oil processed, quality requirements and food safety limitations. The main advantages of chemical refining over physical refining are:

- the flexibility to obtain a high-quality product more or less independently of feedstock pretreatment and quality;
- the possibility to use lower deodorisation temperatures to restrict undesirable by-product formation and to retain desired minor components.

The choice of the best available refining process route also depends on many operational criteria like: processed volume, flexibility with regards to oil type and quality, environmental restrictions, stand-alone refinery or in combination with an oil mill on the same site, etc.

Chemical refining may be preferred for oils high in phospholipids like non-degummed seed oils, water-degummed oils and highly unsaturated oils also high in FFA (low-quality linseed oil, fish oil, etc.). Chemical refining is the most flexible choice for a stand-alone refinery processing seed oils with different pretreatments and qualities. Physical refining may be preferred for oils low in phospholipids and high in FFA like tropical oils. It is also an important refining route for partly processed oils. However, physical refining needs a higher temperature for deodorisation. This may be a barrier in view of food safety.

11.2.2.2 Degumming

Degumming involves the addition of water to hydrate any gums present, followed by centrifugal separation. Non-hydratable gums are removed by converting them first to a hydratable form using phosphoric or citric acid, followed by the addition of water and centrifugation.

Degumming consists of two parts: water degumming and acid degumming. Water degumming is carried out at the oil mill and thus belongs to the oilseed processing. Acid degumming is the first step in refining. Degumming reduces the level of phospholipids in vegetable oils. Phospholipids in vegetable oils originate from the plant tissue (cell membranes). They concentrate in the oil during the oil extraction process. Extracted seed oils like soybean oil, sunflower oil and rapeseed oil are high in phospholipids (generally measured as ppm phosphorus). Palm oil, palm kernel oil and coconut oil are low in phospholipids. Phospholipids need to be reduced in the first step of the refining sequence since they will lead to high bleaching earth consumption, fouling of heating coils and brown colouring of the oil at high temperature. A part of the phospholipids is hydratable. This means that they adhere to water and that they can be removed by water washing (water degumming). The remaining phospholipids are non-hydratable. They need to be treated with acid (citric or phosphoric acid) to make them hydratable. After water or acid dosing and a reaction time, a centrifuge separates the phospholipids from the oil. The separated phospholipids will entrain some oil and impurities; this mixture is called gums or lecithin. Good-quality lecithin from water degumming can be used as an emulsifier in food applications.

The industrial degumming processes are as follows [215, FEDIOL 2015]:

- Water degumming, which only removes the hydratable phospholipids. The level of non-hydratable phospholipids in water-degummed oils is relatively high (above 100 ppm P) and they are difficult to remove by subsequent acid degumming. Water degumming is generally carried out at the oil mill; the removed lecithin can be purified for use as an emulsifier (high-value by-product) or added to the meal and used as feed.
- Acid degumming (see Figure 11.2), which also removes a part of the non-hydratable phospholipids. The phospholipids level in acid degummed oils (10–30 ppm) is much lower than that in water-degummed oils. However, the removed phospholipids are of insufficient quality for lecithin production. They can be exploited by adding them to the meal as feed. Acid degumming can be carried out with citric acid or phosphoric acid (sometimes diluted alkali is added after the reaction time to neutralise the remaining acid). Citric acid is often preferred because of its efficiency and because it chelates metal traces. However, it is not effective for all oils. Phosphoric acid is a stronger acid which is a benefit for oils that are high in non-hydratable phospholipids. However, it increases the phosphorus emission in waste water.
- Water or acid degumming followed by treatment with enzymes. This process has been introduced after efficiency improvement and cost reduction of the enzymes. The enzyme phospholipase-A2 catalyses the splitting of the fatty acid ester under mild conditions. The liquid enzyme is dispersed into the oil at 60 °C and at pH 5, with citric acid and caustic soda as a sodium citrate buffer. To increase the low reaction rate of the enzymatic reaction, a battery of continuous stirred reactors is applied. The resulting lysolecithin molecule is water-soluble and can be separated by centrifugation. The main advantage is the lower oil loss of the degumming process. Implementation depends on the additional costs of the enzymatic process, the oil loss of the process and the value of the by-product. The crude oil quality is more constant when applying enzymatic degumming, compared with acid degumming.
- Degumming combined with chemical neutralisation of the oil. Phosphoric or citric acid is dosed to the oil before addition of a diluted alkali solution. The alkali reacts with FFA to form soap. The phospholipids are removed together with the soap and further treated in the soap-splitting installation. This process is robust and flexible and is the only process that can remove non-hydratable phospholipids from water-degummed oils.

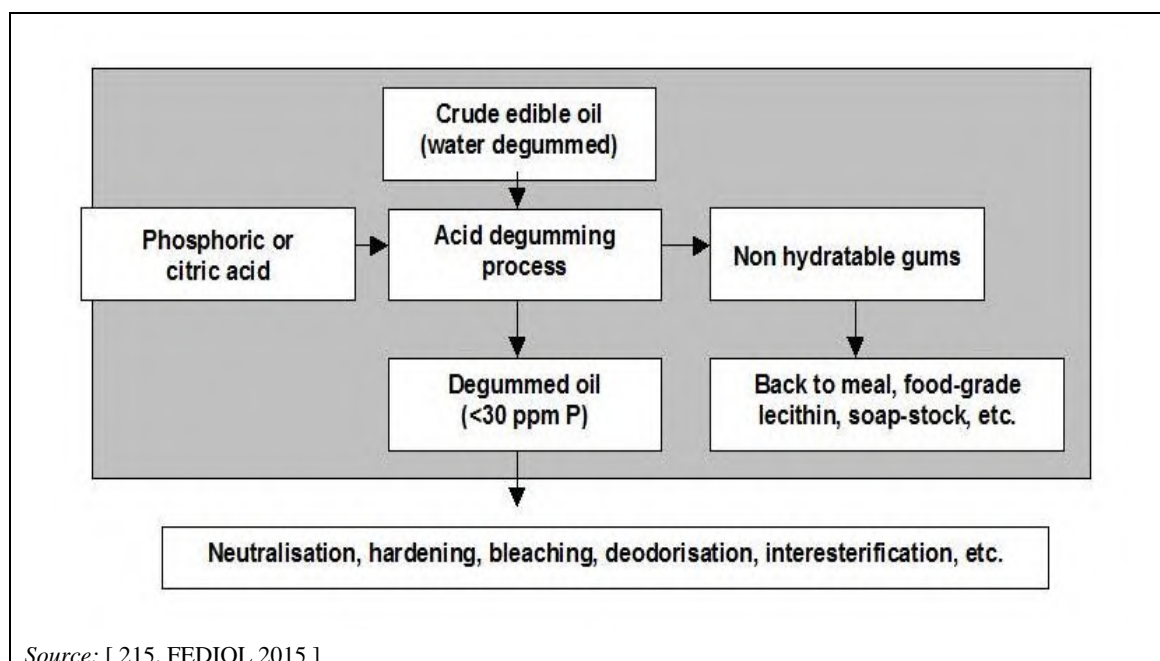

Figure 11.2: Basic flow diagram for the acid degumming of vegetable oil

11.2.2.3 Deodorisation

Deodorisation is the use of steam distillation to strip FFA and other highly volatile components, under vacuum conditions, from oils and fats. The equipment used for deodorisation consists of a steam distillation column, barometric condenser, demisters and scrubbers. Steam is injected into the oil heated to over 200 °C at the bottom of the distillation column, which is under vacuum conditions. The steam strips the FFA and other impurities from the oils and fats but gums are not removed by this process. The steam is condensed afterwards, using a barometric condenser of either once-through or closed-circuit design. The separation of the volatile components from this steam can be enhanced by a one-stage or a two-stage scrubbing/condensation system and by demisters. Deodorisation can be operated in batch or continuous deodorising vessels.

Deodorisation is the final treatment step in the refining process that converts crude oil to finished oil. The pretreated oil is heated up to the deodorising temperature, i.e. 180–270 °C, using a heat exchanger and indirect steam. To prevent oxidation of the oil, the atmosphere in the deodorising equipment is at almost absolute vacuum, i.e. 0.5–8 mbar. At the given vacuum and temperature conditions, stripping steam provides the driving force and the carrier for removing volatile components from the feedstock.

The vapours from the deodoriser vessel contain air, water vapour, fatty acids and other volatiles. Prior to entering the vacuum equipment, the vapours pass a scrubber. A scrubbing liquid is sprayed in the vapour stream. Fatty acids and volatiles partly condense on the scrubbing droplets or alternatively on the packing material. Since the scrubber is at the same vacuum as the deodoriser, water vapour will not condense.

The precleaned vapour stream now enters the booster steam ejector of the multistage vacuum system. The steam jet is a thermo compressor and hence the vapour pressure increases up to 30–50 mbar. In a classically designed vacuum system, the vapours are then condensed in an open barometric condenser. The water vapour coming from stripping steam and pressurised steam is condensed and a tremendous reduction in volume is achieved. This contributes to maintaining the vacuum at the specified levels. Non-condensable components from the barometric main condenser are removed by a de-aerating system comprising one or more small intermediate condensers and one or more small steam ejectors. The condensers also use cooling water, i.e. 10–15 % of the cooling water flows through the main condenser. The water from the barometric condensers may be polluted. The function of one or two steam jets may be replaced by the application of a water ring vacuum pump (see Section 11.4.1.1).

Sections 11.2.2.3.1 to 11.2.2.3.3 describe some techniques used for deodorisation.

11.2.2.3.1 Single wet scrubber in combination with an alkaline closed-circuit system

Vapours (containing fatty acids) coming from the deodoriser are treated in a wet scrubber. The precleaned vapour stream is mixed with the driving steam from a booster steam jet. When the deodoriser feedstock contains higher concentrations of short-chain fatty acids, e.g. coconut oil, the installation of a second scrubber between the booster steam ejector and the main barometric condenser will not reduce the COD pollution load from the once-through system to an acceptable emission level. In such cases, the overall assessment of the technique may conclude that the pollution load of the cooling water return is not acceptable despite the low energy requirements of the once-through cooling system. In this case or in similar situations, alkaline closed-circuit systems can be applied. The installation of a closed-circuit system makes the investment in a second scrubber obsolete.

In this cooling system, the cooling water is circulated in a closed circuit and the volatile components of the vapour stream are mostly trapped in the main condenser. The main and intermediate condensers of the vacuum system may be part of the internal cooling water circuit, with a bleed to the waste water treatment system of the installation via the soap-splitting

installation. Two heat exchangers need to be installed to allow for cleaning. Caustic needs to be added to avoid rapid fouling by fatty material. The pH is raised to approximately 9 in the primary barometric condenser circuit. The condensate from the oil-stripping steam and the ejector steam provides the water needed in the alkaline circuit. Excess water is withdrawn from the alkaline circuit as a soap solution. Soap splitting is carried out in a separate department. The aqueous phase is part of the acid waste water. The introduction of a closed-circuit system increases the steam consumption needed for generating the same vacuum.

The inlet temperature to the main condenser is 5 °C higher than with the open condenser system, which incurs higher steam consumption for the steam ejectors and hence higher cooling water demands. This can make this process impossible under the physical conditions necessary for product quality. Also, the internal closed circuit may be chilled, resulting in increased consumption of electricity and lower driving steam consumption. In this case, the cooling water circuit operates at a lower-temperature emission level because it is cooled by a chiller. Figure 11.3 shows a basic flow diagram of an alkaline closed-circuit cooling water system as part of a deodoriser vacuum system.

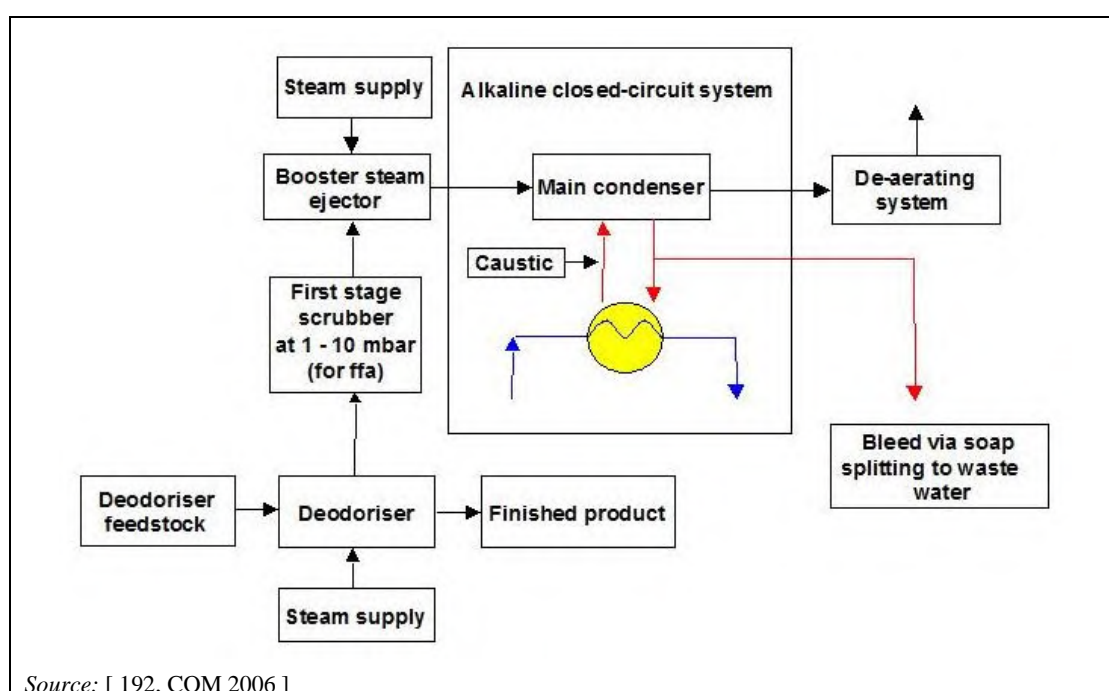

Figure 11.3: Basic flow diagram of an alkaline closed-circuit cooling water system as a part of a deodoriser vacuum system

In the chilled alkaline closed-circuit systems, the stripping steam leaving the deodoriser is compressed by one booster. The combined stripping steam and driving steam of the booster is cooled in a condenser by water circulating in a closed loop through a heat exchanger (primary loop). The secondary loop through the heat exchanger is chilled by a refrigeration system to a few degrees Celsius. Alkaline is dosed in the primary loop to saponify residual fatty acids. The bleed of the primary loop (volume equal to volume of condensed steam) needs treatment with acid to split the soap before treatment in an effluent plant. The coolant compressor can use ammonia as refrigerant. Freon-type refrigerants can be used if local legislation does not allow the use of ammonia [193, TWG 2015].

A 99 % waste water volume reduction has been reported in comparison to once-through cooling (see Section 11.2.2.3.3). The volume of waste water generated is 0.06–0.15 m³/t of unrefined oil. It is reported that when using a closed-circuit system, the complexity increases and the reliability decreases. Closed-circuit systems involve internal heat exchangers, extra pump capacity and chiller installation. The energy requirements for the deodorising step in a refinery

involve more than 50 % of the refinery's total energy consumption. Closed-circuit alternatives, therefore, result in 10–20 % higher specific energy consumption values [192, COM 2006]. Table 11.1 shows energy data of an alkaline closed-circuit system.

Table 11.1: Energy data of an alkaline closed-circuit system

Energy consumption	Specific values	
	German example installation data	Reported data
Electricity (depends on content of FFA in the unrefined oil)	8–10 kWh/t unrefined oil	8–20 kWh/t unrefined oil
Steam	47–117 kWh/t unrefined oil (60–150 kg/t)	39–117 kWh/t unrefined oil (50–150 kg/t)
<i>Source: [192, COM 2006]</i>		

In general, the steam consumption and electrical energy use depends on operating vacuum pressure, the temperature of cooling water or ambient air and the use of ejectors or vacuum pumps to extract the non-condensables. Typically, an alkaline recirculation system running at a suction pressure of 2 mbar (the deodoriser pressure is 3 mbar due to the pressure drop over the scrubber) with two boosters uses around 125 kg steam (excluding stripping steam) and 20 kWh electricity per tonne of deodorised oil [193, TWG 2015].

In the chilled alkaline closed-circuit systems, the steam consumption and electrical energy use depends on operating vacuum pressure and the use of ejectors or vacuum pumps to extract the non-condensables. In an example installation (#274), a chilled alkaline recirculation system running at a suction pressure of 2 mbar (deodoriser pressure of 3 mbar due to the pressure drop over the scrubber) uses around 35 kg steam (excluding stripping steam) and 20 kWh electricity per tonne of deodorised oil.

The technique is generally applied when the deodoriser feedstock contains higher concentrations of short-chain fatty acids, e.g. coconut oil. It is suitable for new and existing installations, and readily available. The space availability may restrict its application.

Under hot climate conditions, where there is a higher risk of process instability, e.g. vacuum fluctuations, the operating reliability is acceptable, in combination with adequate process controls. Under moderate climate conditions and after treatment for the removal of fats from the deodoriser vapours, if the technique is correctly operated its reliability can be very good, mainly due to the robust steam-jet vacuum pumps.

Closed-circuit systems have higher investment costs, operational costs and energy consumption compared to once-through systems. In addition, higher investment costs are reported for chilled closed-circuit systems. Maintenance costs are relatively low. Maintenance of the equipment is done during the planned maintenance of the deodoriser (on average 1 week every two years).

11.2.2.3.2 Single wet scrubber in combination with dry/ice condensing

Dry condensing (DC) systems, also called ice condensing systems, are placed between the wet scrubber and the de-aerating system. The wet scrubber removes the major part of the FFA. The DC system eliminates the remaining part of the FFA and the stripping steam that was used to drive out the FFA. The steam and FFA are condensed on the coils (heat exchanger) of the DC system at temperatures as low as -30 °C. The low temperature is generated by the mechanical compression of ammonia and evaporates it on the coils afterwards. The chiller unit requires extra electricity and cooling water. Only the non-condensable vapours will pass the scrubber and the DC system to the vacuum system. Figure 11.4 shows a basic flow diagram of a single scrubber in combination with a DC system.

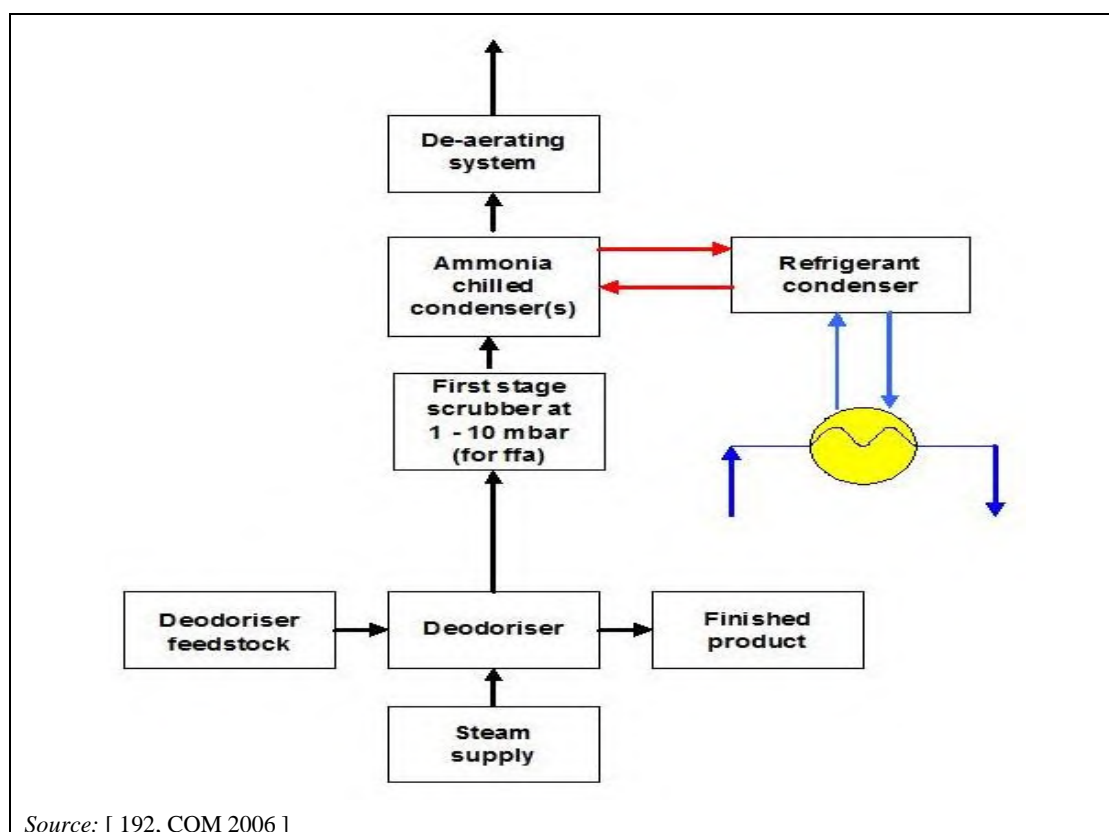

Figure 11.4: Basic flow diagram of a single scrubber in combination with a DC system

It is reported that more than 95 % of all the condensable vapours are removed by the DC system, so the vacuum system can be much smaller [192, COM 2006]. Table 11.2 shows performance data from a case study of a DC system.

Table 11.2: Performance data of an example DC system

Consumption level	Specific values
Water for water ring pumps and for cooling the refrigeration plant for ice condensation	300 kg/t unrefined oil
Electricity (depends on the content of FFA in the unrefined oil)	10.5–21.5 kWh/t unrefined oil
Steam	5.5–15.5 kWh/t (20–150 kg/t) unrefined oil
Waste water	Up to 0.350 m ³ /t unrefined oil. No phosphate or sulphate

Source: [35, Germany 2002]

The polluted water production is generally equal to the steam consumption, approximately 15 kg per tonne of processed oil reported in one installation (#45). There is no solid waste for disposal [193, TWG 2015].

The technique is generally used when applying distillative neutralisation/deodorisation (physical refining). It is suitable for new and existing installations. The space, low vapour fat contents, installation capacity and external safety requirements, e.g. due to the application of ammonia in the refrigeration system, can restrict its applicability. The operating reliability is good, thanks to control technology. The vacuum system is better as it is independent of weather conditions. Each deodoriser unit needs a separate dry condensing system.

The operational availability of the dry condensing system does not generally limit the operational availability of the deodoriser system. Maintenance of the equipment is carried out during the planned maintenance of the deodoriser (on average 1 week every two years).

High investment and maintenance costs are incurred for the implementation of this technique.

An investment cost of EUR 750 000 has been reported for a dry condensing system. Annual operating costs (costs of electricity, steam, cooling water and effluent treatment) of EUR 100 000 have also been reported [193, TWG 2015].

11.2.2.3.3 Double wet scrubber in combination with a once-through cooling system

Vapours are treated in a wet scrubber. The precleaned vapour stream is mixed with the driving steam from the booster steam jet. Installing a second wet scrubber between a booster steam jet and the main condenser allows further condensation of the volatiles, replacing the stripping and driving steam prior to the mixing with cooling water in a once-through cooling system. The second scrubber may have fixed packing material or may be equipped with a dedicated scrubbing loop, a heat exchanger to remove the heat of condensation and a demister pad. The second scrubber operates at a higher pressure and due to the addition of steam, via the booster steam jet, the partial pressure of the volatiles is reduced. These two factors provide the basis for further condensation.

The double scrubber arrangement results in an improved vapour scrubbing efficiency. The additional condensation of volatile components in the second scrubber reduces the mass flow through the system. At the same time, the second scrubber contributes to an additional heat loss; however, the total energy requirements for the system are low. Figure 11.5 shows a basic flow diagram of the process.

The combined stripping steam and driving steam of the booster(s) is cooled in a condenser by surface water (river or lake) or in a closed loop through a cooling tower. Pollution of surface water or the cooling tower by residual fat is kept low by using an efficient fatty acid scrubber between the deodoriser and vacuum system and a fat trap to capture fatty matter from the condenser outlet water.

The operational availability of the once-through vacuum system does not generally limit the operational availability of the deodoriser system. Maintenance of the equipment is carried out during the planned maintenance of the deodoriser (on average 1 week every two years).

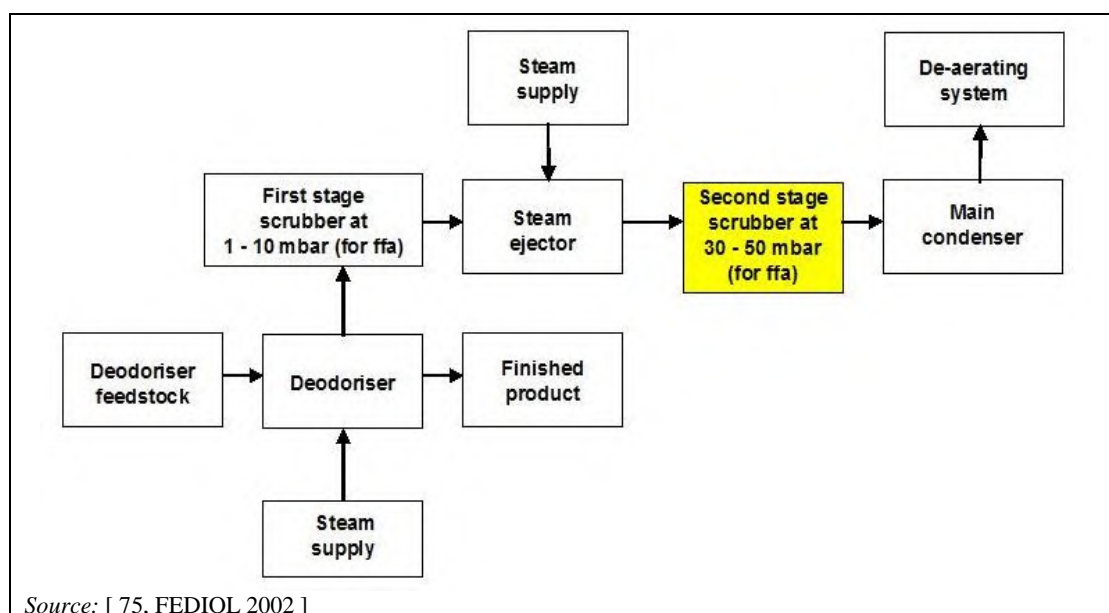

Figure 11.5: Basic flow diagram of the double scrubber arrangement in deodorisation

The scrubbing efficiency of the first scrubber is well above 90 % when the feedstock is chemically refined. This treatment step achieves the initial removal of the bulk of the fatty acids. The second scrubber adds another 2–5 % to the overall scrubbing efficiency [75, FEDIOL 2002]. The scrubber efficiency is related to the input of fatty acids with the deodoriser feedstock. The double scrubber arrangement combined with a once-through cooling system has no heat exchangers. Hence there are no problems with either heat exchanger fouling or related to poor heat transfer issues. Process stability is high due to the simplicity of the system layout.

As the cooling system design is based on steam ejectors and open condensers with direct cooling water, it has the lowest energy requirement for generating the desired vacuum based on the consumption of electricity and steam. However, this system produces a cooling water flow with increased COD levels. The increase in COD levels may vary from 50–150 mg/l depending on the cooling water flow and the quality of the deodoriser feedstock. The double scrubber arrangement results in a smaller increase in COD levels, i.e. 40–100 mg/l. The reported waste water volume is 1–10 m³/t of unrefined oil [75, FEDIOL 2002].

Table 11.3 shows energy data of a double scrubber combined with a once-through cooling system.

Table 11.3: Energy data of a double scrubber combined with a once-through cooling system

Energy consumption	Specific values
Electricity (depends on the content of FFA in the unrefined oil)	2–5 kWh/t unrefined oil
Steam	39–50 kWh/t (50–100 kg/t unrefined oil)
Source: [75, FEDIOL 2002]	

In general, the steam consumption and electrical energy use depend on the operating vacuum pressure, the temperature of cooling water or ambient air and the use of ejectors or vacuum pumps to extract the non-condensables. A once-through system running at a suction pressure of 2 mbar (deodoriser pressure of 3 mbar due to the pressure drop over the scrubber) with two boosters uses around 105 kg steam (excluding stripping steam) and 20 kWh electricity per tonne of deodorised oil. The total energy use for vacuum generation of a once-through vacuum system

is around 15 % lower than that of an alkaline closed-circuit cooling system. The system uses no chemicals [193, TWG 2015].

The technique is suitable for new and existing installations, has good operating reliability and is readily available. The deodoriser feedstock quality should not contain high concentrations of short-chain fatty acids, e.g. coconut oil. Available space is needed for the second scrubber.

The system can operate with only one booster if the maximum surface water or ambient air temperature is very low (around 10 °C). However, for most EU countries the maximum surface water or ambient temperature is around 30 °C, in which case two boosters in series are needed to obtain the low vacuum pressure of 2 mbar.

In general the technique incurs low investment and maintenance costs [193, TWG 2015].

11.2.2.4 Crystallisation of edible oils and fats

Crystallisation of edible oils and fats, also called fractionation, is based on the principle that the solubility of the higher-melting components in the liquid phase change at different temperatures. This difference can be extended by using an organic solvent which has the effect of decreasing the viscosity and leading to better washing of the crystals.

The equipment includes tanks for preheating; stirred and cooled tanks for crystallisation; band or membrane filters for the separation of the crystals from the liquor and distillation vessels for solvent recovery. The oil is heated to 10 °C above the melting point of the highest triacylglycerol present, to give a fully liquid starting material, e.g. the heating point is typically 75 °C for palm oil. The molten oil is then cooled and stirred to form crystal nuclei, and the temperature is maintained at a lower temperature to induce crystal growth, typically for 12 hours at 28–30 °C for palm oil. If a solvent is used, it is added to the molten oil prior to cooling. The mixtures containing the crystallised solids and the dissolved liquids are separated by filters. If a solvent is used, it is removed from the fractions by distillation.

11.2.2.5 Further processing of edible oils and fats – margarine

The main products manufactured from edible oils and fats are margarine, edible fats, edible oils and mayonnaise. In view of its major importance, only margarine production is described here.

Most installations carry out hydrogenation to produce fats with superior retention qualities and higher melting points. Hydrogenation is usually carried out by dispersing hydrogen gas in the oil, in the presence of a finely divided nickel catalyst supported on diatomaceous earth. The resultant hydrogenated fats are filtered to remove the hydrogenation catalyst, subjected to a light earth bleach and deodorised before they can be used for edible purposes. After hardening, the oil is mixed with an aqueous solution to produce an emulsion. The emulsified mixture is then pasteurised, cooled and crystallised to obtain the final product.

Hardening, or hydrogenation of oils, is the process of saturating mono- or polyunsaturated fatty acids by adding hydrogen gas (H₂) for the hydrogenation and nickel as a catalyst. Hydrogen molecules, in the presence of nickel and under special process conditions, saturate the unsaturated bonds of the fatty acids of edible oils. Neutral or bleached oil is heated to a temperature of 150–205 °C in the presence of a nickel catalyst (maximum 10 kg catalyst/tonne of product). H₂ is then added to the mixing reactor to achieve the hardening, i.e. the transformation from oil to fat. Hydrogenation is an exothermic process. After the reaction, the fats are separated from the nickel, using filter presses or other filter systems. In a minority of cases, the nickel catalyst can be reused several times until it is deactivated. Specialist companies recycle the spent nickel. The residual nickel concentration in the fats is removed by bleaching, which produces bleaching earth contaminated with nickel. The equipment used for hardening consists of mixing vessels, reaction tanks, autoclaves and filters.

11.3 Current consumption and emission levels

11.3.1 Energy consumption

The energy consumption during the production of crude vegetable oil depends on the type of raw material, the equipment and the manufacturing processes. Heating, cooling, drying, milling, pressing, evaporation and distillation are the major energy-consuming steps.

Figure 11.6 shows data for specific energy consumption (MWh/tonne of oil produced) from integrated crushing and refining installations. A distinction is also made between the installations depending on the different raw materials they process, showing that the processing of soybeans requires more energy than that of rapeseeds and/or sunflower seeds, due to the latter two having the highest oil content. Figure 11.7 shows data for specific energy consumption (MWh/tonne of oil produced) in stand-alone refining installations.

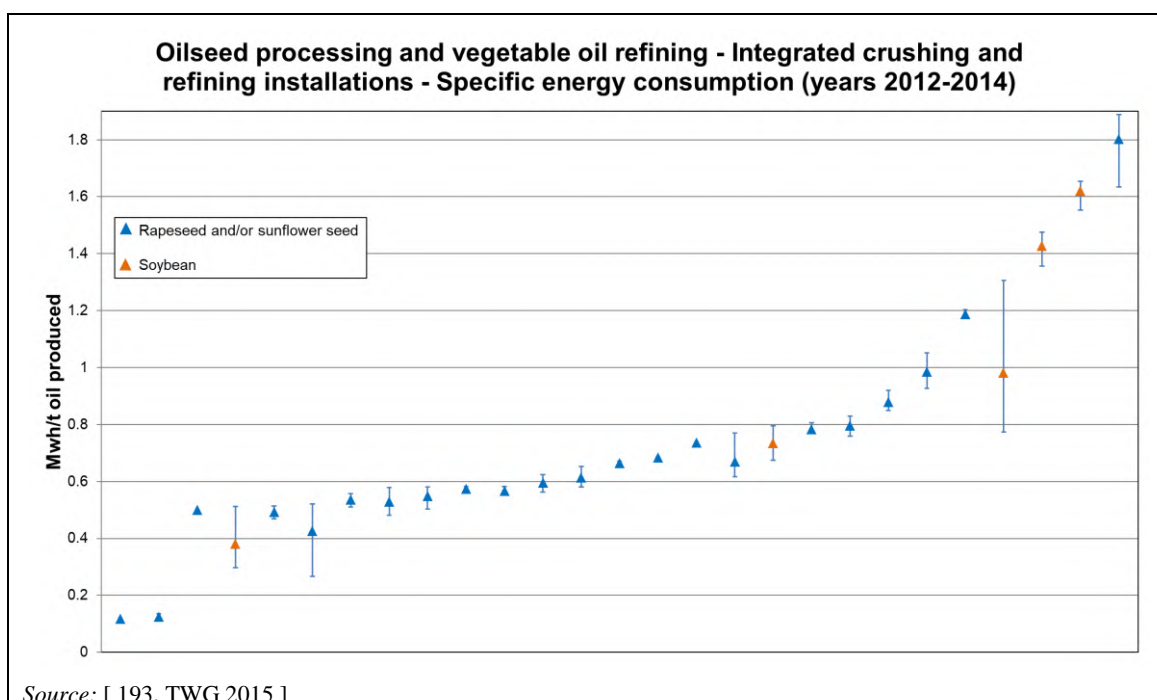

Figure 11.6: Specific energy consumption (MWh/tonne of oil produced) in integrated crushing and refining

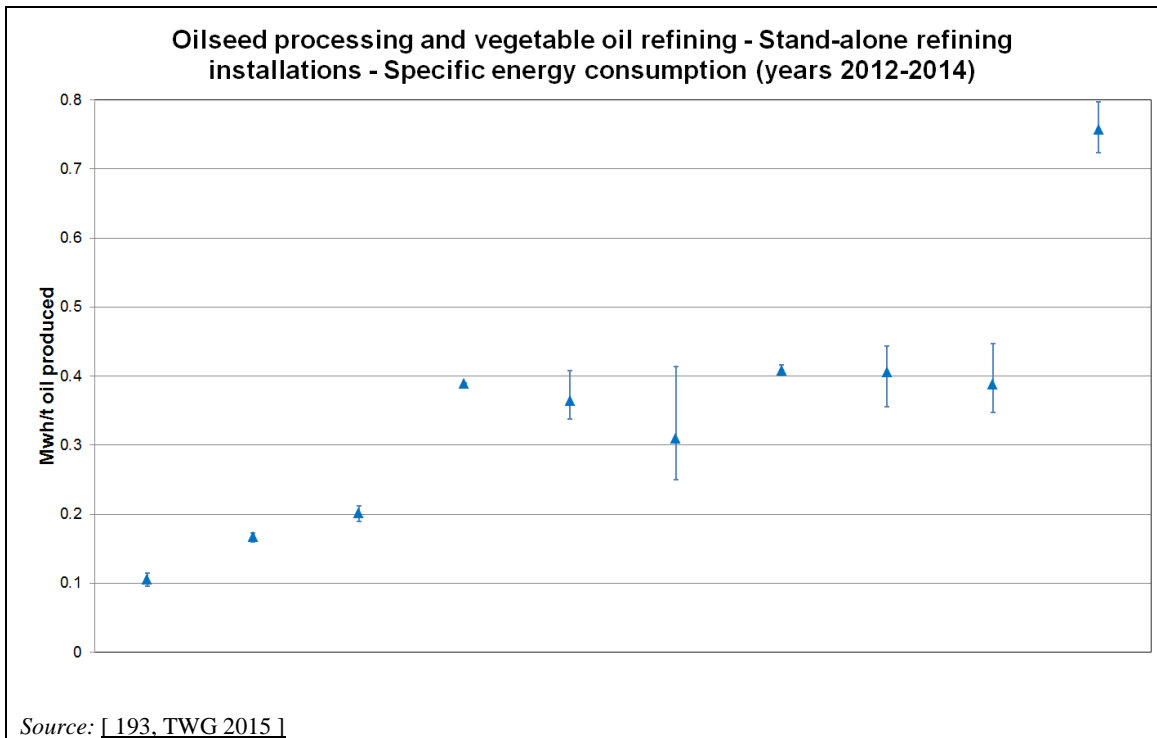

Figure 11.7: Specific energy consumption (MWh/tonne of oil produced) in stand-alone refining

11.3.2 Water consumption

Figure 11.8 shows data for specific water consumption (m^3 /tonne of oil produced) from oilseed processing and vegetable oil refining installations.

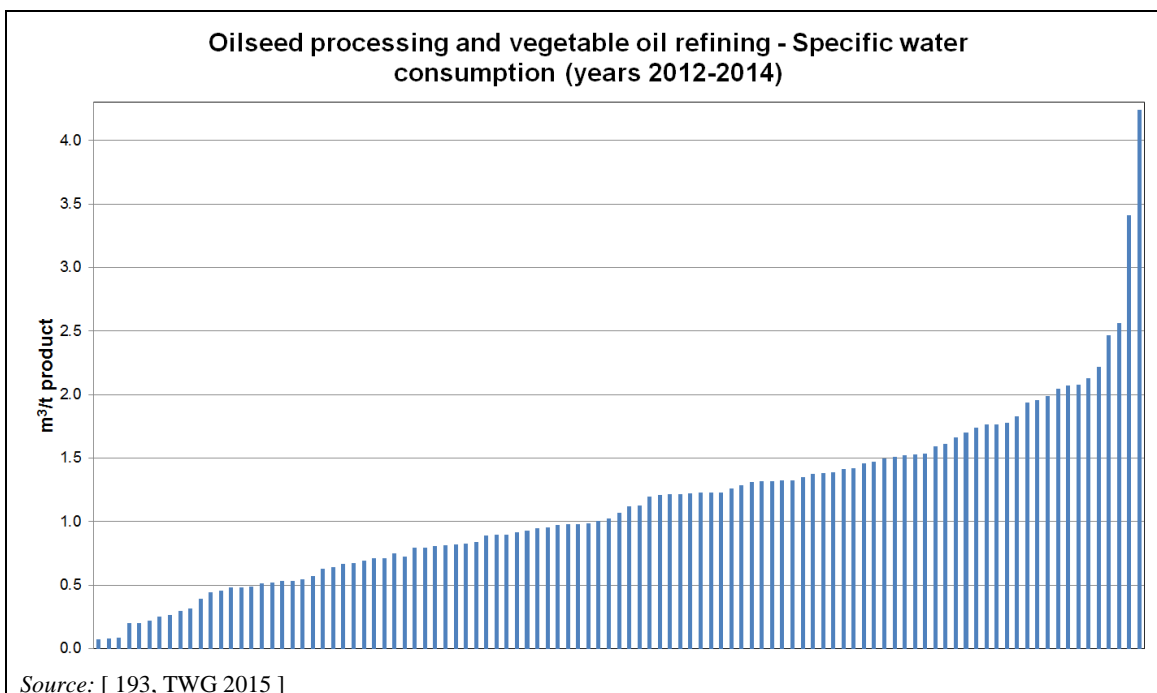

Figure 11.8: Specific water consumption (m^3 /tonne of oil produced) in oilseed processing and vegetable oil refining

In the extraction process of oil from oilseeds with hexane, 0.2–14 m^3 cooling water is needed per tonne of oilseeds. Furthermore, a certain amount of waste water is generated, mainly from

the hexane/water separation, which amounts to 0.2–0.5 m³/t of oilseeds; the load being of 0.1–1 kg COD/t of oilseeds. The amounts of water consumption and of pollution depend on the cooling water system, e.g. once-through or with recycling, and on the kind of oilseeds. The throughput rate of the toaster also has a major influence on these parameters. Water consumption for the pressing of seeds and beans is minimal.

For hardening, water is used for cooling purposes because the end product should not be warmer than 100 °C. Steam, from demineralised water, is necessary to heat the autoclaves and/or reactors. Water is also used for cleaning the installation. The water consumption is between 0.8 m³ and 2 m³ of drinking water and/or demineralised water per tonne of products. This depends on the type of cooling system. Cooling water consumption is between 2 m³ and 5 m³ per tonne of product [62, CIAA-FEDIOL 2002].

11.3.3 Solid output

Depending on the type of vegetable, i.e. oilseed or fruit, the raw materials for vegetable oil production can almost be completely converted into products, e.g. vegetable oil, protein-rich meal, fatty acids and lecithin, or by-products, e.g. for human food, animal feed and pharmaceutical products.

Solid waste, e.g. leaves, wood, pieces of metal and stones, is generated in the raw material's primary treatment step (cleaning and hulling). This is separated during the cleaning of the raw material by wind sifters, magnet separators and sieves. In oilseed production, this fraction is less than 1 % of the processed seeds. Metals are sent for recycling or disposal and the remainder, such as stones and sand, is disposed of. Dust may be incinerated. In the pressing/centrifuging step, used filter cloths from seed pressing are produced and are also disposed of [90, Verband Deutscher Oelmuehlen 2003].

In the case of chemical refining, soap-stock is produced during the neutralisation of crude oil. This consists mainly of NaOH-saponified FFA, but also contains phosphatides, proteins and other compounds. Normally, it is further processed in the refinery by splitting the soaps and regaining the fatty acids (acid oil). In some countries, it is possible to mix the soap-stock from the chemical refining of vegetable oil with other ingredients for the production of low-quality soaps or for use in meal for animal feed.

The production of solid wastes from vegetable oil refining and processing is dependent on the specific site. In bleaching operations, spent bleaching earth containing 20–40 % fat is produced. This makes the waste prone to spontaneous combustion. In production installations which exclusively refine and modify edible oil, the spent bleaching earth is utilised by third parties for energy production by co-fermentation to produce biogas or to make bricks [94, Germany 2003]. The spent catalyst is recycled to third parties for regeneration.

In mixed production installations, which produce crude oil and meal and refine/modify the edible oil, there are further opportunities for utilisation of components of the raw material and of wastes. For example, both phospholipids and spent bleaching earth can be utilised in meal, both as animal feed. The precondition for the use of the latter is the absence of nickel catalyst residues [90, Verband Deutscher Oelmuehlen 2003].

Deodoriser distillate, collected from the steam distillation of refined edible oils, has a variable composition depending on the raw material and the refining process. When arising from physical refining, if the pesticide content is low, it can be used in the feed industry. Otherwise, it can be sold as a source of technical fatty acids. Those from chemical refining have higher values due to their higher tocopherol content. They are an attractive feedstock for the production of vitamin E. Due to the increasing interest in natural antioxidants, such as tocopherol, and the use of phytosterols in the food and pharmaceutical industry, the importance of this distillate will probably increase.

The types of solid/liquid output from different vegetable oil processing unit operations are shown in Table 11.4.

Table 11.4: Summary of key solid/liquid emissions and by-products in the manufacturing of crude vegetable oils

	Degumming	Neutralisation	Bleaching	Deodorisation	Hardening
Solid/liquid output	Mucilage	Soap-stock and spent acids/alkalis	Spent earth containing gums, metals and pigments	Distillates	Spent catalysts and spent filtering aid
<i>Source:</i> [6, Environment Agency of England and Wales 2000], [42, Greek Ministry for the Environment 1997]					

11.3.4 Chemicals used

Ideally, the extraction solvent should only dissolve glycerides and leave undesirable components such as colouring matter, gums and phospholipids. The solvents must not contain toxic components, and should be recoverable with minimum loss, be safe in handling, and be readily removable from the extracted material. For these reasons, aliphatic hydrocarbons, especially hexane, are used almost exclusively. Technical hexane with a boiling point range of 55–70 °C has proved to be the optimum solvent. Hexane can be readily removed from the oil at temperatures below 100 °C under vacuum and can be stripped from the meal with steam. The solubility of hexane in the condensed water is only 0.1 %.

Alcohols like ethanol, isopropanol, methanol, butanol and furfural are especially suited to the extraction of relatively wet materials. The extraction of oilseeds with alcohols leads to relatively high concentrations of phosphatides, glycolipids, carbohydrates, and similar constituents in the crude oil, although the glycerides can, in principle, be concentrated by cooling or extraction of the alcoholic solutions. Alcohols are generally not used as primary extraction solvents. However, they are occasionally used as secondary extraction solvents to remove gossypol from cottonseed meal, thioglycosides from rapeseed meal, sugars from soybean meal (to produce protein concentrates), and alkaloids from bitter lupine meal. A new technology is oil supercritical propane or carbon dioxide extraction, where extraction takes place under high pressure. This process is reserved for special products of high intrinsic value because of the high equipment costs involved [51, Ullmann 2001].

Chemicals are used in the chemical neutralisation of crude oil. A total of 1–6 kg NaOH /t oil is used depending on the function of the type of oil and the FFA content of the pre-degummed, or not, crude oil. If phosphoric acid is used, 0.1–2.0 kg/t oil is consumed. Alternatively, citric acid may also be used; its consumption is 0.1–1.0 kg/t oil. Sulphuric acid used in soap-stock splitting amounts to 100–250 kg H₂SO₄/t soap [62, CIAA-FEDIOL 2002].

11.3.5 Emissions to water

Figure 11.9 shows reported data on specific waste water discharges (m^3/tonne of oil produced) from integrated crushing and refining installations and all types of discharges. A distinction is also made between the installations depending on the different raw materials they process, showing higher waste water generation for soybeans due to their lower oil content. Figure 11.10 shows data for specific waste water discharge (m^3/tonne of oil produced) in stand-alone refining installations and all types of discharges. More information on emissions to water can be found in Section 2.2.3.

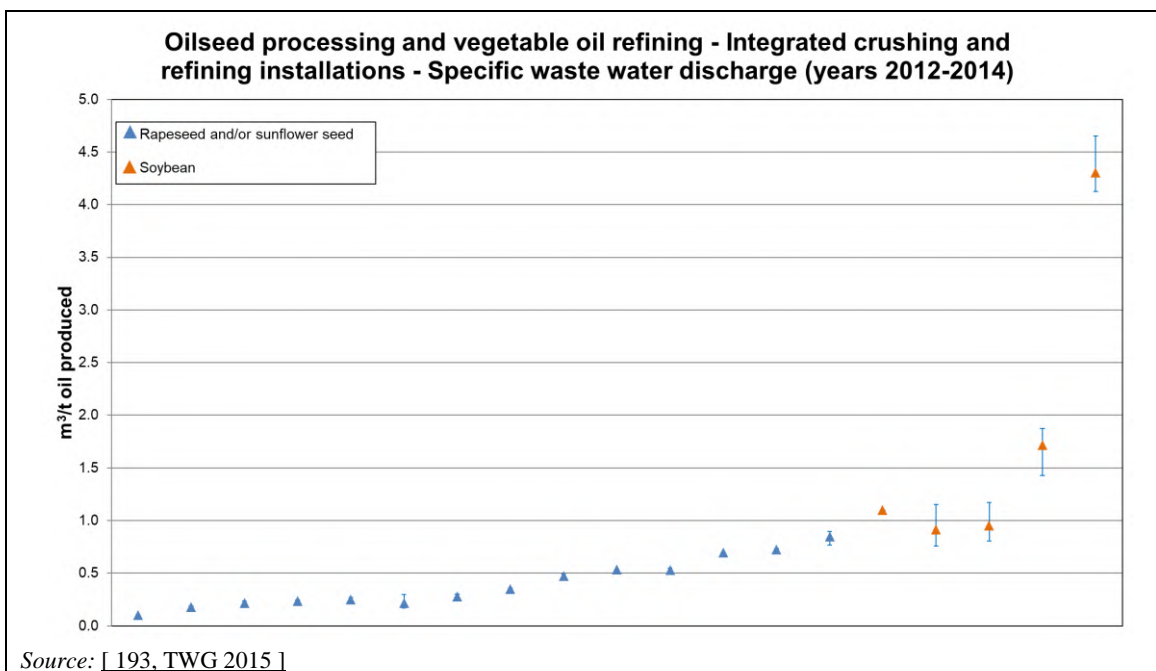

Figure 11.9: Specific waste water discharge (m^3/tonne of oil produced) in integrated crushing and refining for all types of discharges

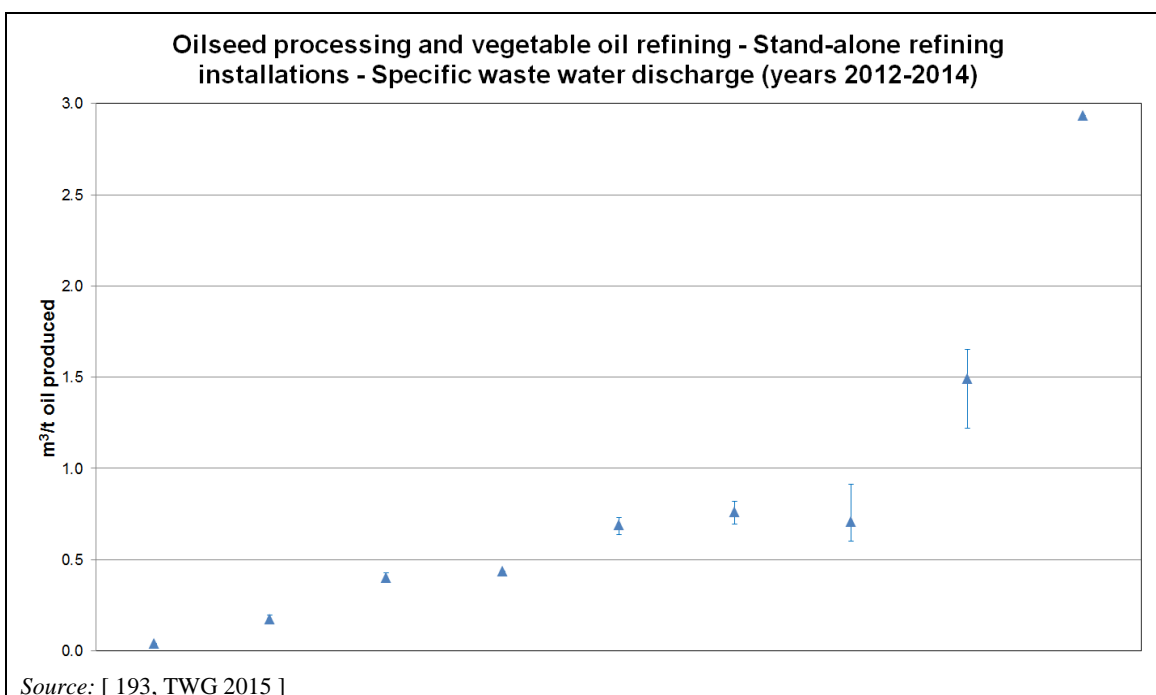

Figure 11.10: Specific waste water discharge (m^3/tonne of oil produced) in stand-alone refining for all types of discharges

11.3.6 Emissions to air

11.3.6.1 Dust emissions from seed processing / drying and cooling of meal

Dry dust is generated during seed delivery, silo storage, seed cleaning, seed preparation, meal shipment and indoor transportation/conveying. Wet dust can arise during seed preparation, meal drying and cooling, and indoor transportation/conveying.

Bag filters and cyclones or a combination of the two (cyclones as a first step) are mainly used as final abatement techniques for the dust emissions from seed processing. The most common emission sources are raw materials loading/unloading, raw material storage and transport, and raw material cleaning and seed drying. Cyclones are used as a final abatement technique for the dust emissions from the drying and cooling of meal.

A general overview of the data received for dust emissions from seed processing / drying and cooling of meal is shown in Figure 11.11, Figure 11.12 and Figure 11.13.

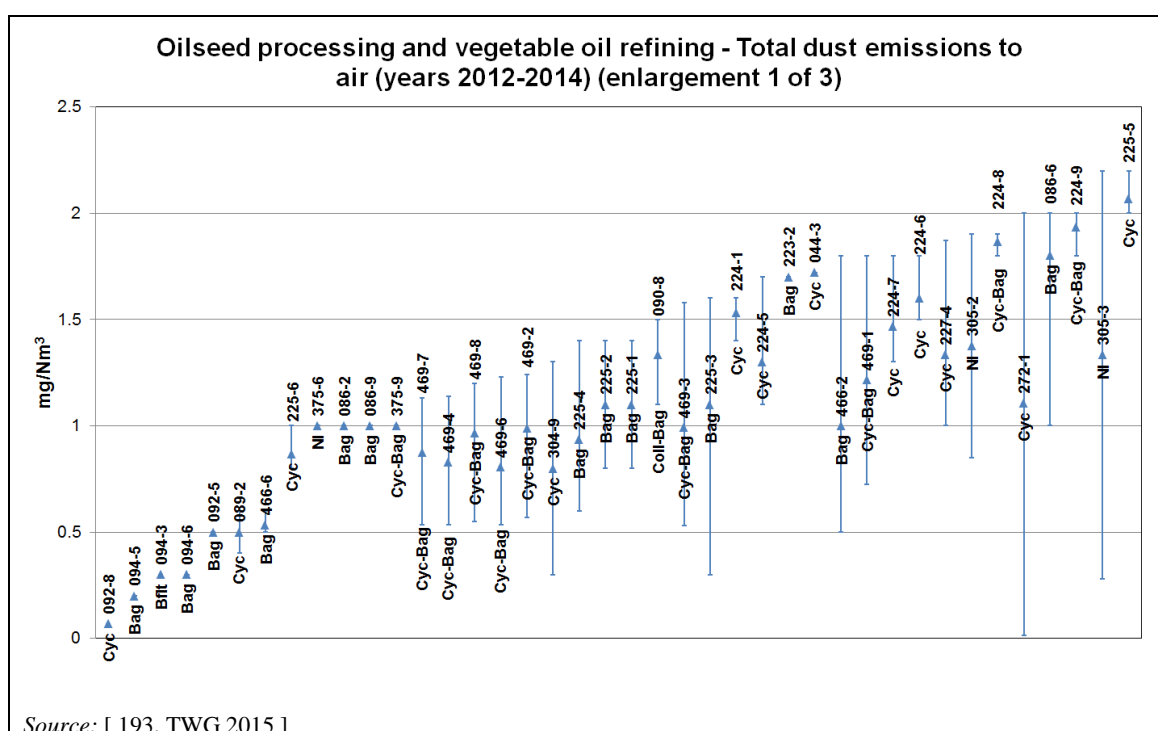

Figure 11.11: Total dust emissions to air from seed processing (1 of 3)

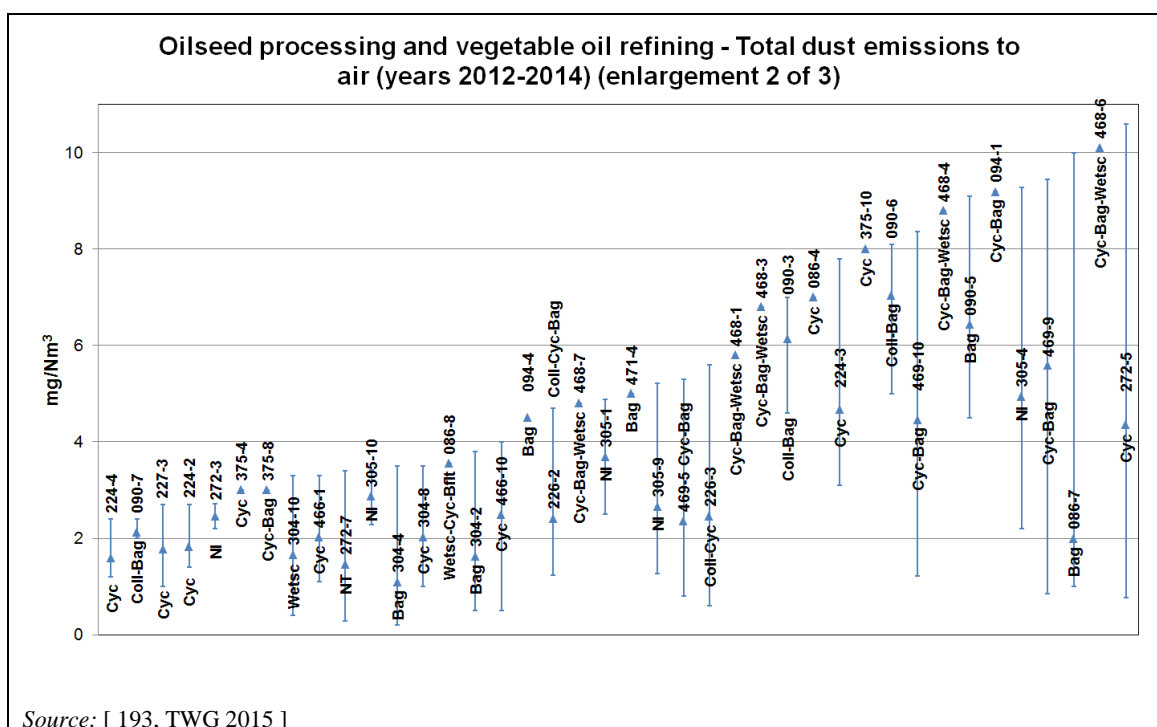

Figure 11.12: Total dust emissions to air from seed processing (2 of 3)

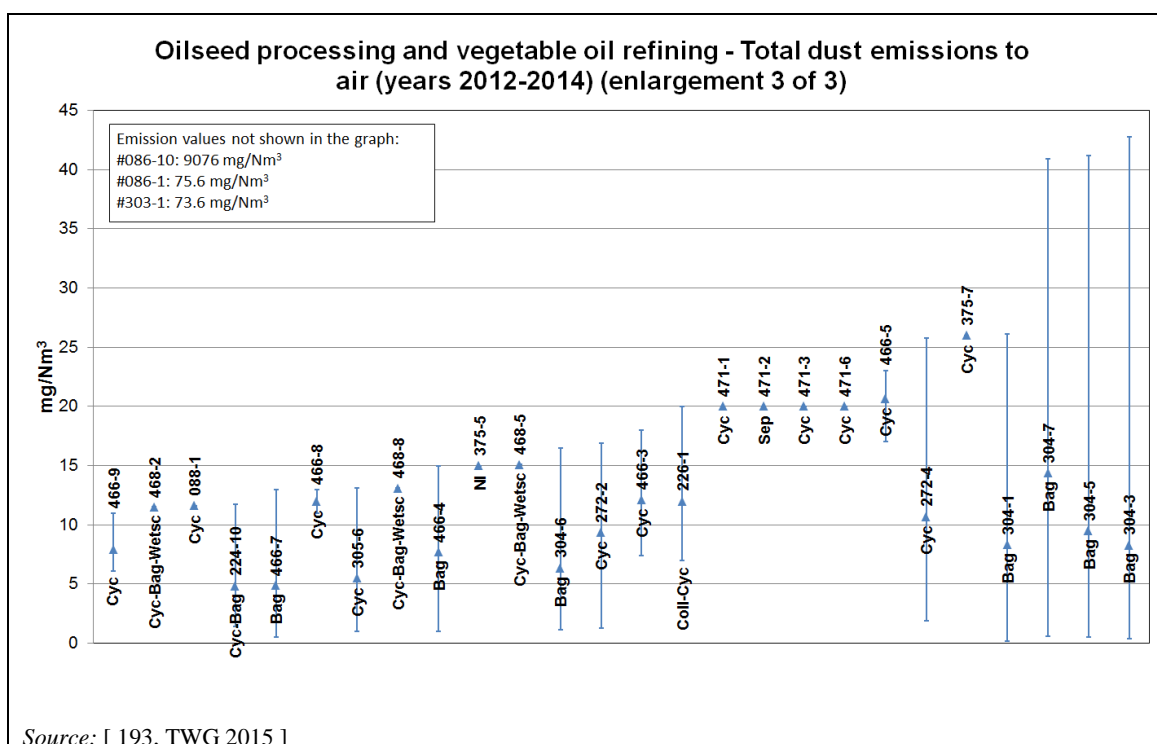

Figure 11.13: Total dust emissions to air from seed processing (3 of 3)

The meaning of the symbols and abbreviations used in Figure 11.11, Figure 11.12 and Figure 11.13 are indicated in Table 3.3 and Table 3.4.

11.3.6.2 TVOC emissions

Data from monitoring of channelled TVOC emissions are shown in Figure 11.14. Channelled emissions include those from the desolventising process and the drying and cooling of meal.

The majority (typically > 90 %) of TVOC emissions to air consist of hexane. Hexane emissions are typically reduced by the hexane recovery techniques described in Section 11.4.2.4. Biofilters, bioscrubbers and wet scrubbers followed by condensation are typically used with the intention of reducing odour emissions (e.g. sulphur-containing substances). Moreover, hexane is a hydrophobic compound that is not abated by biofiltration or bioscrubbing. Information on the application of thermal oxidation in Figure 11.14 comes from a pomace installation, which is not included in this sector.

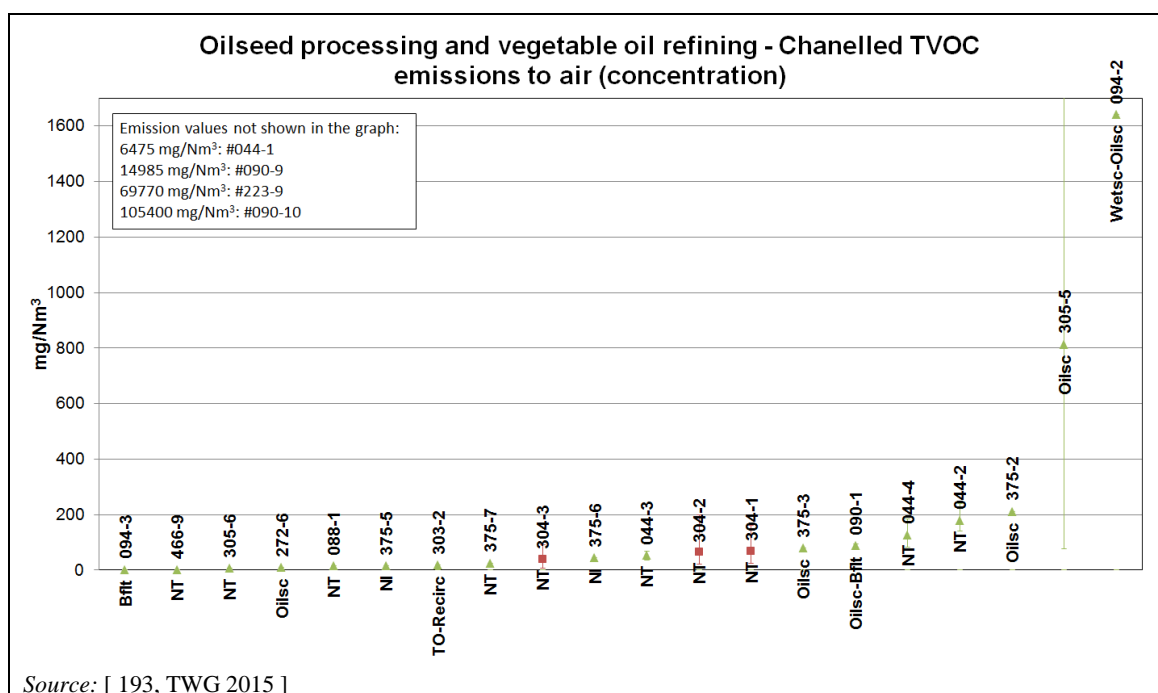

Figure 11.14: TVOC emissions to air from oilseed processing and vegetable oil refining

The meaning of the symbols and abbreviations used in Figure 11.14 are indicated in Table 3.3 and Table 3.4.

11.3.6.3 Hexane losses

The hexane recovery cycle is effective but some losses of hexane occur during oilseed processing. In a typical extraction installation, the following sources and causes of hexane loss can be distinguished [214, FEDIOL 2015]:

- residual hexane in meal (after desolventising-toasting and drying/cooling);
- residual hexane in crude oil (after miscella distillation and oil stripping);
- exhaust from the mineral oil absorption system;
- exhaust from the meal dryer and meal cooler vents;
- process waste water (after hexane-water separator and reboiler);
- fugitive losses from equipment leaks, e.g. via seals, gaskets and flanges, sight glass mountings.

The following factors determine hexane loss during oilseed processing [214, FEDIOL 2015]:

- the hexane retention characteristics of the meal which are influenced by the oilseed type, its geographical origin and the climatic conditions during its cultivation;
- the local ambient temperatures, affecting the effectiveness of condensing/cooling systems involved in the hexane recovery processes;
- the complex interrelationship of consecutive processing steps; operators aim to strike a balance between installation capacity utilisation, throughput, oil yields, product quality considerations, energy efficiency, process safety, hexane loss and processing cost and margins.

In more detail, hexane losses can generally be attributed as follows [223, FEDIOL 2014]:

- hexane losses via meal are generally predominant in the total losses and are typically in the range of 30–60 %;
- hexane losses via oil are typically in the range of 2–6 % of total hexane losses;
- the combined hexane loss via the exhaust from the mineral oil absorber and meal drying/cooling vents typically represents 5–20 % of total hexane losses;
- the process water is virtually hexane-free and hexane losses via water fed to the waste water system are negligible;
- the combined losses associated with evaporative losses from equipment leaks and start-up and shutdown operations may explain the balance of the hexane losses.

An indicative contribution of sources of hexane losses during oilseed processing is shown in Table 11.5.

Table 11.5: Indicative contribution of sources of hexane losses during oilseed processing

Sources of hexane loss	kg hexane per tonne of seeds
Meal	0.05–0.3
Crude oil	0.02–0.05
Exhaust from mineral oil system and drying/cooling vents	0.05–0.15
Waste water	Negligible
Fugitive losses and losses from start-ups and shutdowns	0.1–0.5
<i>Source: [223, FEDIOL 2014]</i>	

The total emission limit value in the IED for solvents consumption for rapeseed and sunflower seed processing is higher than that for soybeans [98, TWG 2017]. A general overview of the data received for specific hexane losses (which are equivalent to specific hexane consumption) is shown (in anonymised form) in Figure 11.15.

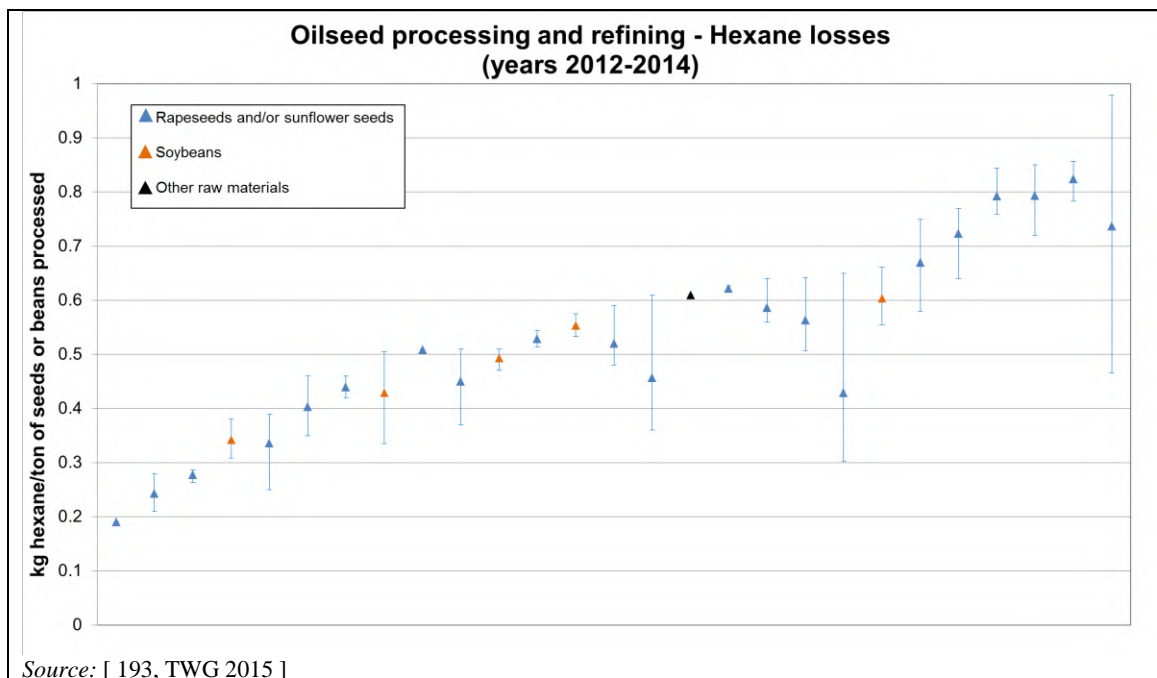

Figure 11.15: Specific hexane losses (kg per tonne of seeds or beans processed)

11.3.6.4 Odour emissions

Odour is produced in all steps where heating is involved. It results from the volatile fatty acids, organic nitrogen compounds and, in the case of rapeseed, hydrogen sulphide and organic sulphur compounds.

The exhausts from aspiration systems in seed preparation and seed pressing, exhausts from meal drying and cooling and the exhaust from the mineral oil system are sources of odour emissions. Odour emissions are generally higher for rapeseeds than for soybeans due to the presence of sulphur-containing substances (H_2S) in the rapeseeds. The sulphur content of the rapeseeds may depend on the crop variety and agricultural practices applied. Sulphur-containing organic substances may decompose under the influence of seeds/meal being exposed to relatively high temperatures in seed heating, seed pressing, seed extraction and meal desolventising-toasting and meal drying/cooling. Hydrogen sulphide can be a key odour component in the exhaust of the mineral oil system of a rapeseed crushing installation. Odour can be an issue when the emitting installation is relatively close to residential areas.

11.4 Techniques to consider in the determination of BAT

11.4.1 Techniques to increase energy efficiency

11.4.1.1 Generation of an auxiliary vacuum

Description

The auxiliary vacuum used for oil drying, oil degassing or minimisation of oil oxidation is generated by pumps, steam injectors, etc. The vacuum reduces the amount of thermal energy needed for these process steps.

Technical description

Water ring pumps generate a low stable vacuum which can be used for degassing and drying of oils and fats of animal and vegetable origin. When degassing the oil, the vacuum is used during hydrogenation, where H₂ is used, and after interesterification, where water is used to inactivate the catalyst. When drying the oil, a vacuum is used after degumming, after neutralisation, before and after interesterification and before hydrogenation. A vacuum is also used to ensure an oxygen-free atmosphere in the reactor/evacuating reactor during hydrogenation and interesterification.

Achieved environmental benefits

Reduced energy requirements. Low pollution of the waste water. Reduced emissions from energy generation.

Environmental performance and operational data

Waste water results from the water used to drive the pumps. This is generally characterised by a low specific volume per unit. Owing to the applications, such water is only slightly polluted at the point of origin, even if it contains condensates from the drying processes. The load can be described in terms of its COD level, because nitrogen or phosphorus compounds cannot be carried into such water in significant quantities under the prevailing process conditions, e.g. temperatures ≤ 100 °C. The reported volume of waste water is up to 1.7 m³/t of unrefined oil and the COD level is up to 75 mg/l.

Cross-media effects

Generation of waste water.

Technical considerations relevant to applicability

The technique is applicable when a vacuum range of 40–120 mbar is required. It is readily available and its operating reliability is very good, allowing series production. Completely different vacuum conditions are required for distillative neutralisation/deodorisation.

Economics

No information provided.

Driving force for implementation

Reduced costs due to appropriate vacuum conditions.

Example plants

No information provided.

Reference literature

[35, Germany 2002], [100, Bockisch M. 1993]

11.4.2 Techniques to reduce emissions to air

11.4.2.1 Reduction of dust emissions from seed handling and preparation

11.4.2.1.1 Bag filter

The technique is generally described in Section 2.3.7.2.2.

Environmental performance and operational data

Table 11.6 shows installation-specific performance data related to the application of bag filters for dust abatement. The reported data refer to dry gas, unless otherwise indicated in the "Additional information" column.

Table 11.6: Total dust emissions to air from seed handling, preparation and drying after treatment in a bag filter

Installation ID-point of release	Dust (mg/Nm ³)	O ₂ content (%)	Monitoring standard	Frequency of monitoring	Additional information
094-5	0.20	NI	EN 13284-1	Once every three years	Rapeseeds Receipt of raw material (rape receipt, washing)
092-5	0.50	NI	EN 13284-1	Once every three years	Rapeseeds Dust extraction ship unloading
304-3	0.60	21.00	EN 13284-1	Twice a year	Sunflower seeds, rapeseeds Seed cleaning
466-2	0.70	NI	EN 13284-1	Yearly	Soybeans, rapeseeds Soybeans sieve
469-3	0.86	21.00	PN-Z-0403-7	Yearly	Rapeseeds Rapeseed storing Cyclone step before
225-4	0.93	20.90	EN 13284-1	Biennial	Soybeans Preparation
086-2	1.00	20.90	EN 13284-1	Once every three years	Soybeans, rapeseeds Crushing soybeans (flakers)
304-4	1.30	21.00	EN 13284-1	Biennial	Sunflowers, rapeseeds, corn germ Corn germ dryer Tubular filter Wet dust
225-2	1.40	20.00	EN 13284-1	Biennial	Soybeans Seed drying Wet dust
469-8	1.15	21.00	PN-Z-0403-7	Yearly	Rapeseeds Rapeseed unloading Cyclone step before
223-2	1.70	NI	EN 13284-1	Yearly	Soybeans Silos
224-8	1.80	NI	NI	Biennial	Sunflower seeds Cyclone step before Seed drying
304-7	1.90	21.00	EN 13284-1	Twice a year	Sunflower seeds, rapeseeds Hexpeller
305-4	2.20	NI	EN 13284-1	Yearly	Soybeans Flaking mills

375-8	3.00	20.90	NI	Once every three years	Soybeans, rapeseeds, sunflower seeds Seeds precleaning, cleaning, grinding, dehulling and hulls grinding dedusting Cyclone step before
471-4	5.00	NI	NI	Yearly	Sunflower seeds Seed cleaning
090-3	7.00	20.90	VDI 2066	Once every three years	Rapeseeds Rapeseed conveying system
094-1	9.19	20.90	EN 13284-1	Once every three years	Rapeseeds Seed drying and bulk container Cyclone step before Wet dust
NB: NI = No information provided. Source: [193, TWG 2015]					

Technical considerations relevant to applicability

This technique may not be applicable to the abatement of sticky dust from drying and cooling of meal.

Reference literature

[193, TWG 2015]

11.4.2.1.2 Cyclone

The technique is generally described in Section 2.3.7.2.3.

Environmental performance and operational data

Table 11.7 shows installation-specific performance data related to the application of cyclones as dust abatement technique. The reported data refer to dry gas, unless otherwise indicated in the "Additional information" column.

Table 11.7: Total dust emissions to air from seed handling, preparation and drying after treatment in a cyclone

Installation ID-point of release	Dust (mg/Nm ³)	O ₂ content (%)	Monitoring standard	Frequency of monitoring	Additional information
092-8	0.07	NI	NI	NI	Rapeseeds Bruised grain upload
272-2	1.29	NA	NA	Yearly	Sunflower seeds Expeller aeration system (seed side)
224-1	1.40	NA	NA	Biennial	Sunflower seeds Preparation of seed
227-3	1.60	20.90	EN 13284	Biennial	Soybeans Seed preparation
224-4	2.40	NI	NI	Biennial	Sunflower seeds Dehulling
375-4	3.00	20.90	NA	Once every three years	Soybeans, rapeseeds Seeds precleaning, cleaning, grinding, dehulling and hulls grinding
466-1	3.30	NA	EN 13284-1	Yearly	Soybeans, rapeseeds Soya flakers (white flakes line)
466-10	4.00	NA	EN 13284-1	Yearly	Soybeans, rapeseeds Flakes transport
304-8	5.25	21.00	EN 13284-1	Twice a year	Sunflower seeds, rapeseeds Flaking
226-1	7.00	20.30	EN 13284-1	Yearly	Soybeans Seed preparation Wet dust
375-10	8.00	20.90	NA	Once every three years	Soybeans, rapeseeds Seeds precleaning, cleaning, grinding, dehulling and hulls grinding
466-3	11.00	NA	EN 13284-1	Yearly	Soybeans, rapeseeds Soya flakes aspiration Wet dust

NB: NI = no information provided.
Source: [193, TWG 2015]

Reference literature

[193, TWG 2015]

11.4.2.1.3 Wet scrubber

The technique is generally described in Section 2.3.7.3.1.

Environmental performance and operational data

Table 11.8 shows installation-specific performance data related to the application of wet scrubber as dust abatement technique.

Table 11.8: Dust emissions to air from seed handling preparation and drying after treatment in a wet scrubber (dry basis)

Installation ID-point of release	Dust (mg/Nm ³)	O ₂ content (%)	Monitoring standard	Frequency of monitoring	Additional information
304-10	1.60	21.00	EN 13284-1	Twice a year	Sunflower seeds, rapeseeds Milling
468-7	4.80	20.90	PN-Z-04030-7	Yearly	Rapeseeds Cyclone and bag filter step before Rapeseed storing
468-1	5.80				
468-3	6.80				
468-4	8.80				
468-6	10.10				
468-2	11.50				
468-8	13.10				
468-5	15.10				
<i>Source:</i> [193, TWG 2015]					

Reference literature

[193, TWG 2015]

11.4.2.2 Reduction of dust emissions from the drying and cooling of meal

11.4.2.2.1 Cyclone

For general information about cyclones see Section 2.3.7.2.3.

Technical description

Following the extraction of oil from crushed oilseeds, the desolventised and toasted meal is dried and cooled with ambient air. The exhaust air from the drying and cooling contains dust. Due to the relatively high humidity of the exhaust air from the drying stage, the dust is wet and sticky. This sticky dust is difficult to separate from the airstream. A good method for carrying out this separation is the use of cyclones. Their use enables a relatively smooth and uninterrupted dust removal from the dryer and cooler exhaust air. Dust collected by the cyclones can be returned to the dried meal. Therefore, cyclones are used for practical and safety reasons.

The use of fabric filter systems would lead to the condensation of the moisture, causing the deposition of dust and blockage of ducts. The combination of hot drying air and deposited meal dust can eventually result in the self-ignition of the dust, which could start a fire. Such fires present an especially hazardous situation because of the proximity of the hexane-wet flakes in the preceding desolventising-toasting section.

Electrostatic precipitators also create a fire and explosion risk due to sparking in combination with incidental high hexane concentrations in the exhaust air. The fine moist and sticky meal particles tend to agglomerate, causing the fraction of fine particles in the exhaust gases to be relatively low. In this sense, these separators, normally designed for the removal of fine particles, are not suitable. Furthermore, the dried meal particles would become wet in the scrubber and the collected meal would then have to be dried again.

Figure 11.16 shows a basic flow diagram of wet dust emission separation by cyclones.

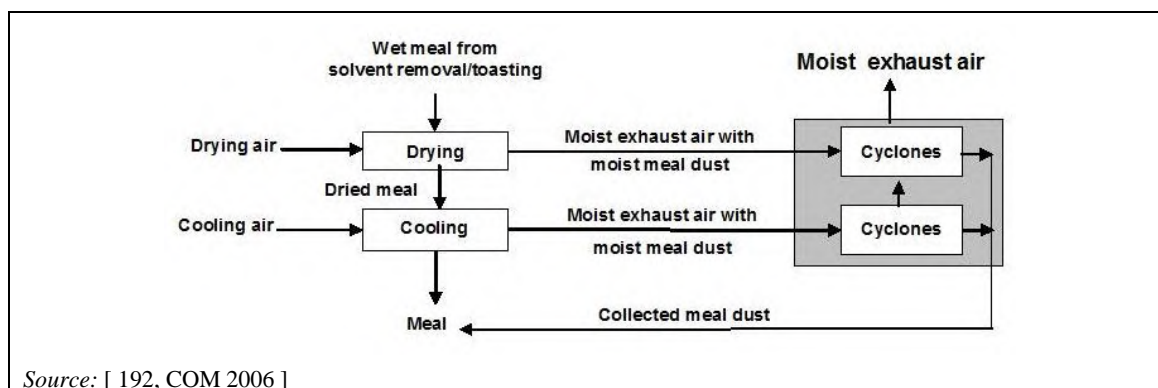

Figure 11.16: Basic flow diagram of wet dust emission separation by cyclones

Achieved environmental benefits

Reduced dust emissions, recovered product and reduced fire risk.

Environmental performance and operational data

Table 11.9 shows installation-specific performance data related to the application of cyclones as a dust abatement technique.

Table 11.9: Average values of periodic measurements of dust emissions from the drying and cooling of meal after treatment in a cyclone (dry basis)

Installation ID-point of release	Dust (mg/Nm ³)	O ₂ content (%)	Monitoring standard	Frequency of monitoring	Additional information
272-7	0.29	NI	EN 13284-1	Yearly	Sunflower seeds Meal dryer
305-6	1.00	21.00	EN 13284	Yearly	Soybeans Meal dryer/cooler
225-6	1.00	20.90	EN 13284-1	Biennial	Soybeans Meal cooler
224-7	1.80	NI	NI	Biennial	Sunflower seeds Meal dryer
225-5	2.20	20.90	EN 13284-1	Biennial	Soybeans Meal dryer
226-3	5.60	20.90	EN 13284-1	Yearly	Soybeans Meal dryer
086-4	7.00	20.90	EN 13284-1	NI	Soybeans, rapeseeds Meal dryer/cooler
466-9	11.00	NI	EN 13284-1	Yearly	Soybeans, rapeseeds Exhaust from meal drying and cooling
088-1	11.60	NI	VDI 2066	Yearly	Soybeans Exhaust from meal drying and cooling

NB: NI = no information provided.
Source: [193, TWG 2015]

Reference literature

[75, FEDIOL 2002], [192, COM 2006], [193, TWG 2015]

11.4.2.3 Reduction of odour emissions

11.4.2.3.1 Bioscrubber

For general information see Section 2.3.7.3.5.

Environmental performance and operational data

Off-gases from the mineral oil system of a rapeseed extraction installation contain a lot of sulphur compounds generating odour, especially H₂S. A Belgian rapeseed installation (#044) applied a bioscrubber and achieved a reduction of around 97 % of the sulphur compounds (removal of 2–3 kg H₂S per hour), with a minor consumption of chemicals and with the generation of only a minor amount of waste. Similar results were reported in another installation (#92).

Reference literature

[193, TWG 2015]

11.4.2.3.2 Biofilter

For general information see Section 2.3.7.3.4.

Environmental performance and operational data

In one oilseed installation (#094), a biofilter is used for exhaust air purification. TVOC emissions of 2 mg/Nm³ have been reported (monitoring standard, EN 13649). In another oilseed installation (#090), the process exhaust air from the pressing plant and extraction is passed through a biofilter. An average TVOC emission level of 87.9 mg/Nm³ has been reported (based on three spot measurements). The monitoring standard used for both cases is EN 13649. Electricity is needed to operate the fan to push the exhaust air through the biofilter (fans together have a power of 120 kW at full load). Approximately 4.5 m³ water/d are consumed for humidification of the filter material. The filter material has to be changed, depending on the load, every 3–5 years.

In another oilseed installation (#466), a biofilter was used to treat a total exhaust of 85 000 m³ emissions in 2014. A reduction of 37 % in odour emissions was achieved, resulting in odour emissions of 30 718 OU_E/m³.

Reference literature

[193, TWG 2015]

11.4.2.3.3 Wet scrubber in combination with a biofilter

Description

Reduction of odour emissions with the combined application of a wet scrubber and a biofilter.

Technical description

The exhaust air scrubber removes dirt and oil particles from the exhaust of vapours, drying, and cooling decks of the DC and other aspiration exhaust from conveyers. With a pump and nozzles, washing water is nebulised into the exhaust volume flow to dispense the particles. The water is recirculated for cleaning the exhaust. By cooling the air and because of the high moisture, the exhaust air condensates. The condensate is pumped into the water treatment plant.

After precleaning the exhaust, a cooling tower decreases its temperature to approximately 40 °C, which is needed as the inlet temperature for the biofilter. The biofilter is made of concrete. The air is led into two chambers that are filled with biofilter material. This material is spread with a bacterial fluid for removing the odour. Finally, the cleaned air is blown into the atmosphere.

Achieved environmental benefits

Reduction of odour emissions.

Environmental performance and operational data

A German installation (#086) reported odour abatement efficiencies higher than 99 %. Electricity consumption for the scrubber was around 616 MWh and for the biofilter around 680 MWh. The biofilter needs an inlet temperature of maximum 40 °C and 100 % relative humidity. A total of 20 m³/d of water and aqueous nutrition are supplied periodically at two layers across the entire biobed area. A corrosion inhibitor, a biocide and a disperser for the cooling tower are also supplied.

Cross-media effects

Water consumption is needed to moisturise the biobed and fill up the cooling tower or scrubbers when necessary.

Technical considerations relevant to applicability

Space is required for installing the abatement techniques.

Economics

An investment cost of around EUR 1 700 000 and a yearly operating cost of around EUR 165 000 have been reported.

Driving force for implementation

Reduction of odour emissions.

Example plants

At least one rapeseed installation in Germany (#86).

Reference literature

[193, TWG 2015]

11.4.2.4 Recovery of hexane

11.4.2.4.1 Monitoring of hexane losses using a mass balance (bookkeeping process)

Description

The technique includes using installation purchase records, weighing records and inventories with regard to hexane and oilseeds. Residual hexane in oil and meal is periodically measured. Monitoring devices are installed that will trigger an alarm in the event of incidental releases of hexane, e.g. caused by leakages or spills. Monitoring of critical temperatures, pressures and flows in the process equipment involved in hexane recovery can also be carried out.

Technical description

Monitoring of specific hexane losses (e.g. kg hexane per tonne of oilseeds processed as a yearly average) on the basis of a mass balance constitutes a cost-efficient method for assessing the overall performance of the combined process-integrated hexane recovery systems. Operators usually focus on total installation hexane losses and more specifically on kg of hexane losses per tonne of oilseeds processed over a longer period of time, typically one year. The specific hexane losses (equivalent to hexane consumption) as a yearly average includes losses from all sources and conditions throughout the year. The monitoring includes using installation purchase records, weighing records and inventories with regard to hexane and oilseeds, and is also known as the bookkeeping process.

Operators monitor hexane purchases and on-site hexane inventories much more often so as to be able to control unusual deviations in hexane losses. The monitoring of specific hexane losses (loss per tonne of oilseeds processed) is based on existing installation purchase records and inventories of hexane and oilseeds. Moreover, in the framework of product quality control, residual hexane in oil and meal is routinely measured.

The monitoring of specific hexane losses as a yearly average is complemented and aligned with product quality control practices that ensure routine measuring of residual hexane in oil and meal. In addition, for process safety reasons, monitoring devices are installed that will trigger an alarm in the event of incidental releases of hexane, e.g. caused by leakages or spills. Indirectly, hexane losses are also monitored through the monitoring of critical temperatures, pressures and flows in the process equipment involved in hexane recovery. In fact, the explosion risk prevention measures ensure the prevention of prolonged releases or elevated emissions of hexane.

Detailed information about the methodology of the mass balance evaluation can be found in Part 7 of Annex VII to the IED [125, EU 2010].

Achieved environmental benefits

Environmental performance is optimised and hexane losses can be reduced.

Environmental performance and operational data

Monitoring of hexane losses with the bookkeeping process is implemented in a lot of oilseed installations, even on a daily basis.

Values (as annual averages) from 0.19 kg to 0.78 kg hexane per tonne of crushed seeds/beans have been reported.

Cross-media effects

No information provided.

Technical considerations relevant to applicability

Generally, there are no technical restrictions to the applicability of this technique.

Economics

Quantifying total losses on the basis of bookkeeping principles is preferred over quantifying hexane losses from sampling and testing of individual emission points in terms of cost-efficiency.

Driving force for implementation

Compliance with environmental legislation.

Example plants

Various installations across Europe.

Reference literature

[125, EU 2010], [193, TWG 2015]

11.4.2.4.2 Countercurrent flow of meal and steam in the desolventiser-toaster

Description

Hexane is removed from the hexane-laden meal in a desolventiser-toaster (DT) involving a countercurrent flow of steam and meal.

Technical description

After oil extraction, the meal contains 25–40 % solvent. The solvent is removed by evaporation in the desolventiser-toaster (DT) by means of direct and indirect steam. The DT vessel has several predesolventising and desolventising/stripping decks. The meal from the extractor enters the DT via the top and arrives at the first predesolventising deck. The predesolventising decks have only indirect steam heating to flash off the surface solvent. This configuration reduces the amount of water condensed on the meal at the stripping sections, thereby reducing the energy input needed for the following meal drying step.

Direct steam is introduced in the system via a sparge steam deck at the bottom of the DT. The steam migrates through the layers of meal on each deck. A large proportion of the hexane is removed from the meal due to condensation of steam on the meal. The DT demonstrates a countercurrent flow of live sparge steam and meal. The steam consumption is minimised by the countercurrent flow and the application of predesolventising decks. Vapours from the stripping decks and predesolventising decks are combined inside the boundaries of the DT vessel and reused elsewhere in the extraction process as a heating medium in the miscella distillation after scrubbing (see Section 11.2.2.3.1). Due to the contact of steam with the meal, toasting takes place as well. The toasting process inactivates the enzymes, thus ensuring the optimum protein quality of the meal for use as animal feed and improving its digestibility [75, FEDIOL 2002]. Figure 11.17 depicts a basic flow diagram of a countercurrent flow in a meal DT.

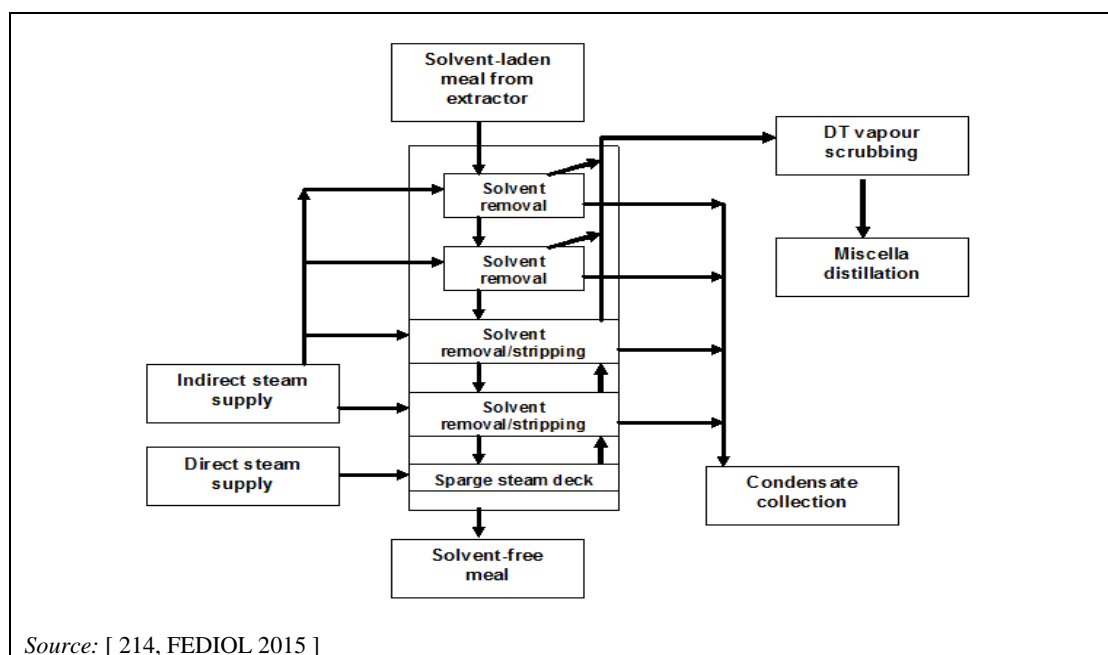

Figure 11.17: Countercurrent flow in the desolventiser-toaster

Achieved environmental benefits

Reduction of solvent losses into the meal and the environment. Reduction in steam consumption for the desolventising and meal drying process. Reduced volumes of waste water. More balanced heat integration with the miscella distillation system, thus reducing the need for hot and cold utilities.

Environmental performance and operational data

Energy consumption is normally given for the DT and downstream drying operation as a whole. For example, by predesolventising via indirect steam in the top decks, the amount of water condensed on the meal at the stripping sections is reduced in comparison with the case when direct steam is applied. Subsequently, the energy input needed for the following meal drying step is reduced.

Table 11.10 shows energy consumption data for the DT and downstream drying operation in oilseed extraction.

Table 11.10: Energy consumption data for the DT and downstream drying operation in oilseed extraction

Heating steam	15.55–31.11	kWh/t
	56–112	MJ/t
	20–40	kg/t
Stripping steam	54.44–116.66	kWh/t
	196–420	MJ/t
	70–150	kg/t
Electricity for DT drive	2–5	kWh/t
	7–18	MJ/t
<i>Source:</i> [192, COM 2006]		

It is reported that the countercurrent flow enables the operator to maintain acceptable residual solvent levels in the meal exiting the DT to minimise the hexane losses of the extraction process and also to minimise the temperature of the vapour mixture leaving the DT at the same time. At higher vapour temperatures, the consumption of indirect steam increases.

The DT vapours are reused in the first evaporator of the miscella distillation system (see Section 11.4.2.4.3). The final evaporation and stripping is completed with steam. The condensate mixture of water and hexane is separated in a solvent-water separator. The hexane is reused and the waste water is discharged to the WWTP. The waste water contains only COD and Kjeldahl nitrogen.

Technical considerations relevant to applicability

The technique is suitable for new and existing installations. It is easily available and has a good operating reliability.

Economics

High initial investment costs. Reduction in energy costs for the extraction installation.

Driving force for implementation

- Potential lower residual solvent levels in the meal.
- Reduction of installation operating costs.
- Increased installation safety.
- Ensured operational safety of the downstream process.
- Compliance with legislation controlling VOC.

Reference literature

[75, FEDIOL 2002], [192, COM 2006], [214, FEDIOL 2015]

11.4.2.4.3 Evaporation from the oil/hexane mixture

Description

Hexane is removed from the oil/hexane mixture using evaporators. The vapours from the desolventiser-toaster (steam/hexane mixture) are used to provide thermal energy in the first stage of the evaporation.

Technical

The DT removes the hexane from the meal (see Section 11.4.2.4.2). The vapours from the DT stage (steam/hexane mixture) are fed to the first stage of the miscella distillation pre-evaporator to provide a heat source, thus recovering energy. Additional removal of hexane from the concentrated miscella (oil/hexane mixture) takes place in a second-stage evaporator and in a third-stage oil stripper.

description

Figure 11.18 shows a flow diagram of the vapour-heat integration in the DT.

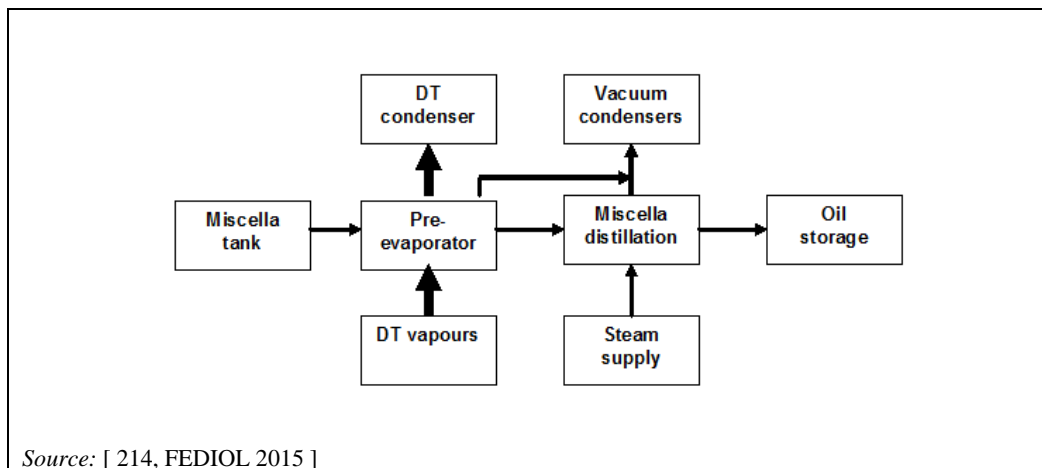

Figure 11.18: Vapour-heat integration in the desolventiser-toaster

Achieved environmental benefits

Reduced energy and solvent consumption.

Environmental performance and operational data

The reported energy savings in the extraction process amount to approximately 37.5 kWh/t (135 MJ/t) (60 kg steam/t) of seeds. Energy is also saved by reducing the heat load to the cooling water system of the installation.

In the pre-evaporator, the miscella concentration (% oil in hexane/oil mixture) increases from approximately 20–30 % to 60–75 %. For example, when processing soya, the pre-evaporator arrangement results in an evaporation of about 0.4 tonnes hexane per tonne of seeds based on the DT vapour waste heat availability. This represents a significant amount of the fresh solvent input to the extraction. The reuse of the energy value reduces the heat load to the DT condenser. Also, the steam demand for the downstream miscella distillation is minimised.

Cross-media effects

No information provided.

Technical considerations relevant to applicability

The technique is widely applicable in oilseed extraction. It is easily available and has a good operating reliability.

Economics

High initial investment. Reduction of installation operating costs due to energy recovery.

Driving force for implementation

- Optimisation of the miscella distillation energy balance.
- Improved installation safety.
- Compliance with governmental energy-saving schemes.

Example plants

No information provided.

Reference literature

[75, FEDIOL 2002], [214, FEDIOL 2015]

11.4.2.4.4 Condensation in combination with a mineral oil wet scrubber

Description

Hexane vapours are cooled to below their dew point so that they condense. Non-condensed hexane is absorbed in a scrubber using mineral oil as a scrubbing liquid for subsequent recovery.

Technical description

Hexane and steam vapours coming from meal desolventising-toasting, miscella distillation, the reboiler and from the stripping column of the mineral oil system all pass through a condenser. The components that cannot be condensed by the condenser, e.g. very low-volume exhaust air with traces of hexane, are absorbed by a mineral oil scrubber.

The mineral oil scrubber consists of an absorption column, where the hexane is absorbed by cold food-grade mineral oil. The hexane-laden mineral oil is then passed through a steam stripping column to recover the hexane. The mineral oil is cooled and reused in the absorption column.

The hexane and steam vapour from the steam stripping column are condensed in the condenser. The hexane-water condensate then goes to the hexane-water separator. The waste water is decanted in the hexane-water separator and the hexane is recirculated to the extraction process. The process is shown in Figure 11.19.

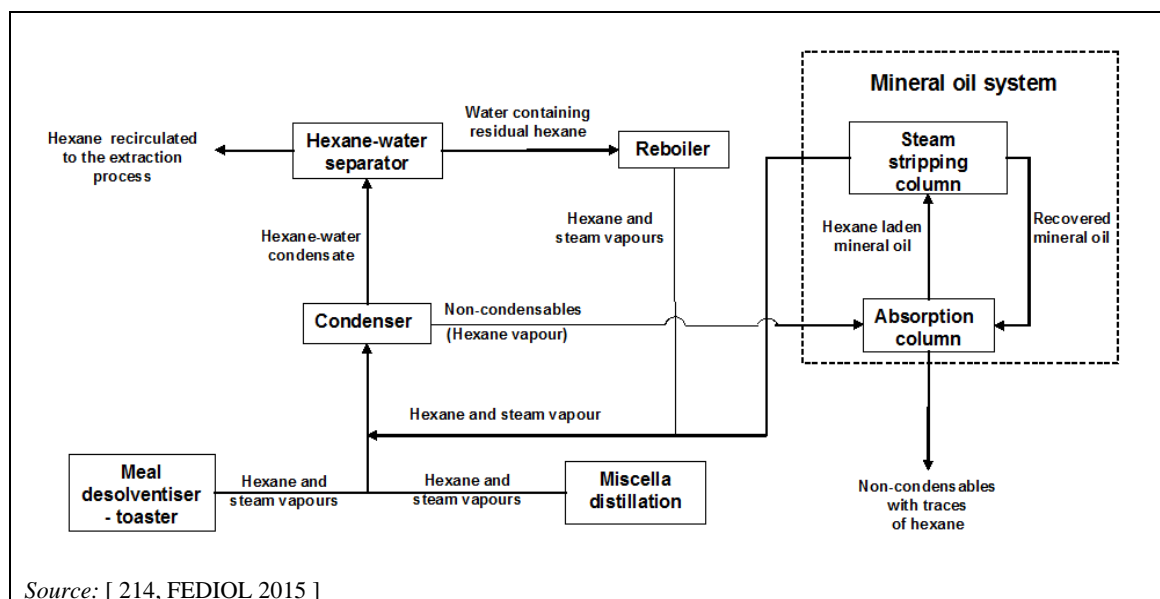

Source: [214, FEDIOL 2015]

Figure 11.19: Mineral oil system and related process steps

Achieved environmental benefits

Recovery of hexane for reuse and consequently lower TVOC emission levels.

Environmental performance and operational data

Hexane emission concentrations below the lower explosive limit, e.g. approximately 40 g/m^3 , can be achieved. The energy consumption is approximately 25 kg steam/tonne of seeds and 0.5 kWh/tonne of seeds.

Cross-media effects

Extra energy consumption, mainly due to heating the mineral oil, using stripping steam and from using electrical power for pumping the oil.

Technical considerations relevant to applicability

This technique is suitable for new and existing installations. It has good operating reliability and is readily available.

Economics

Investment costs are high and there are extra operating costs due to the additional energy consumption. Costs are saved due to hexane recovery.

Driving force for implementation

Better installation safety, recovery and reuse of hexane, legislation controlling TVOC emissions and lack of a better alternative for food-grade mineral oil as an absorption liquid.

Example plants

Widely applied in the oilseed processing and vegetable oil refining sector.

Reference literature

[75, FEDIOL 2002], [214, FEDIOL 2015]

11.4.2.4.5 Gravitational phase separation in combination with distillation

Description

Undissolved hexane is separated from the aqueous phase by means of a gravitational phase separator. Any residual hexane is distilled off by heating the aqueous phase to approximately 80–95 °C.

Technical description

The oil extraction process uses hexane as a solvent. As a consequence, hexane-rich vapour condenses to form process water containing hexane at temperatures of around 50 °C. The undissolved hexane is largely separated by means of a gravitational phase separator, i.e. hexane-water separator.

Any residual solvent content in the aqueous phase of the hexane-water separator is distilled off by heating the aqueous phase to approximately 80–95 °C in the reboiler. The resulting hexane-water vapours from the reboiler are condensed together with the vapours from the miscella distillation stage. The non-condensable gaseous matter of the vapours is treated in the mineral oil scrubber after the condenser where residual hexane is absorbed (see Section 11.4.2.4.4).

All recovered hexane is reused in the extraction process. After boiling, the almost hexane-free water is fed to the WWTP. This technique also eliminates possible risks of explosion from solvent-rich wastes in the downstream WWTP. The process is shown in Figure 11.20. The safety of a WWTP is ensured by preventing explosive hexane-air mixtures.

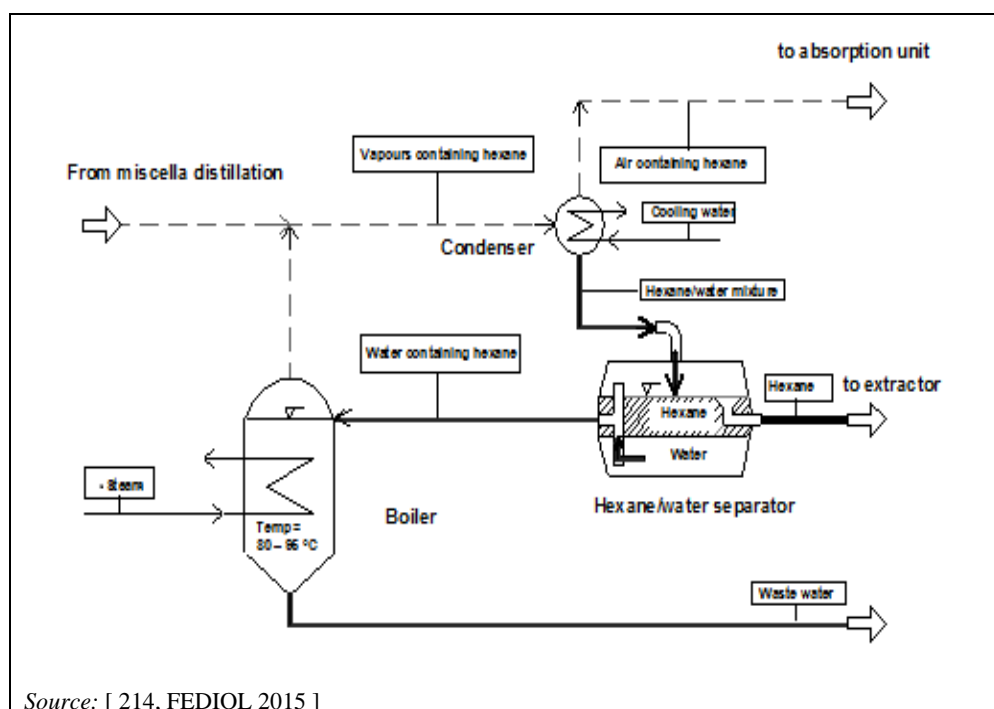

Figure 11.20: Process flow diagram for hexane recovery from process water in the extraction of unrefined vegetable oils

Achieved environmental benefits

Reduced consumption and emission of hexane. Minimisation of TOC or COD, and the BOD load in the waste water.

Cross-media effects

Increased input of heat energy. Increased waste water temperature.

Environmental performance and operational data

Steam is consumed at a rate of 0.778 kWh/m³ water (1 kg/m³). The hexane content in the waste water is less than 3 mg/l. The recovery of hexane is approximately 5 kg/t of seeds [192, COM 2006].

Technical considerations relevant to applicability

The technique is universally applicable and readily available, without any restrictions. The operating reliability is very good, due to the multistage design, temperature control and monitoring.

Economics

No information provided.

Driving force for implementation

- Reduced costs due to smaller hexane losses.
- Ensure installation safety.
- Meet local waste water limit values for hydrocarbons.
- Comply with statutory solvent retention requirements, including legislation controlling VOCs.

Example plants

Installation #223 [193, TWG 2015].

Reference literature

[35, Germany 2002], [75, FEDIOL 2002], [100, Bockisch M. 1993], [192, COM 2006], [193, TWG 2015], [214, FEDIOL 2015]

11.5 Emerging techniques

11.5.1 Use of substances other than hexane for oil extraction

Description

Bio-based solvents or supercritical carbon dioxide have been reported as alternatives to hexane for oil extraction.

Technical description

2-methyltetrahydrofuran (MeTHF) appears to be a promising alternative to n-hexane for the extraction of vegetable oils. MeTHF, produced from biomass like corncobs, sugar cane bagasse or oat hulls, is one of these 'green' and bio-based solvents. It can be synthesised from levulinic acid or furfural produced from C5 and C6 sugars of cellulose and can be degraded by solar light and air.

The use of ethanol as bio-based solvent is being developed in a pilot plant by the Fraunhofer Center for Chemical-Biotechnological Processes (see Figure 11.21). This makes it possible to significantly improve the quality of the rapeseed oil and rapeseed concentrate products. In addition, the pilot plant also aims to isolate novel recoverable substances that previously could not be obtained from rapeseed, such as secondary plant constituents or protein fractions [24, Fraunhofer CBP 2019].

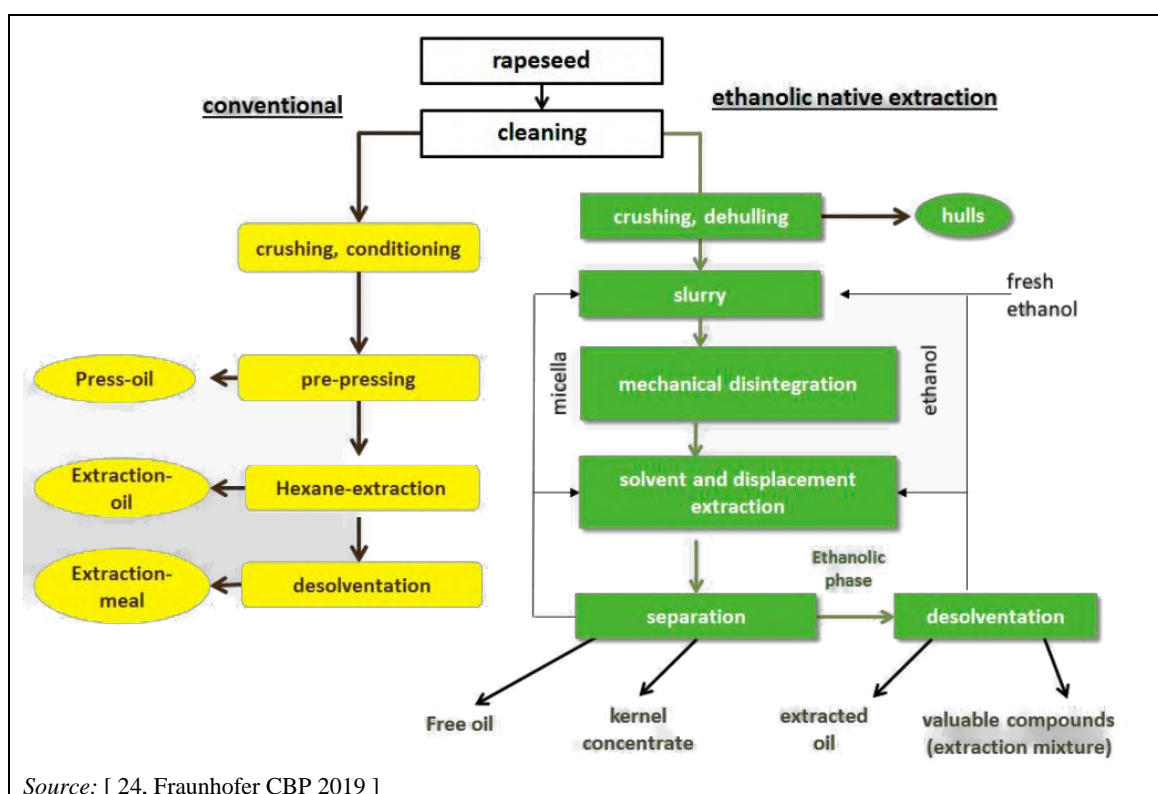

Figure 11.21: Schematic representation of the processing of rapeseed. Left) classical method and right) processing according to the concept of ethanolic, mild extraction

Supercritical extraction can produce a pure, highly concentrated extract. This method is also less damaging to the active ingredients than the methods using heat and/or chemicals. The process takes place in closed system. The extract is separated from the carbon dioxide in two stages: first gravitationally and then by centrifugation. Afterwards, the carbon dioxide is cooled again for liquefaction and recycled.

Reference literature

[98, TWG 2017]

12 OLIVE OIL PROCESSING AND REFINING

12.1 General information about the sector

In 2014, the EU was the largest producer of olive oil in the world, accounting for almost three quarters of global production. Olive trees are grown in Spain, Italy, Greece, Portugal, France, Croatia, Cyprus, Slovenia and Malta — although 99.5 % of the olive production in the EU-28 in 2014 was concentrated in the first four of these nine EU Member States (see Figure 12.1).

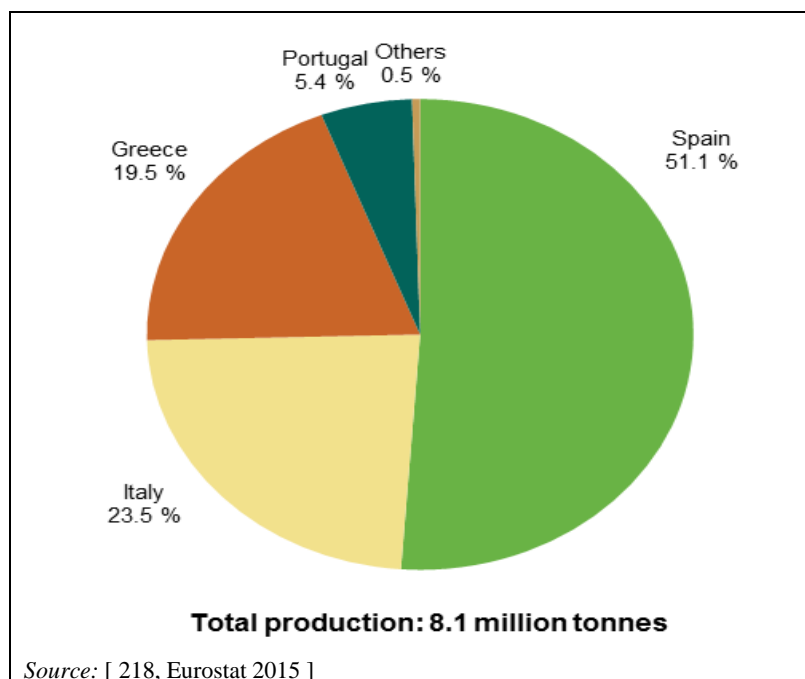

Figure 12.1: Production of olives for olive oil by main producing EU Member States in 2014 (% share of EU-28 production)

In 2007, there were 1.9 million farms with olive groves in the EU. The olive sector is characterised by a large number of small operations. Olive oil production in Spain (413 000 holdings with an average size of 5.3 ha) seems to be relatively less fragmented than in Greece (531 000 holdings with an average size of 1.6 ha) or in Italy, which has the highest number of holdings (776 000, with an average size of 1.3 ha).

12.2 Applied processes and techniques

Olive oil refers to the product obtained from *Olea europea*. It is composed of about 98 % glycerides with the remaining 2 % being various components naturally present in olives, some of which play a fundamental role in the olfactory and taste characteristics and which are also important for the stability and quality of the product.

Extra virgin oils, virgin oils and ordinary virgin oils are edible; yet only extra virgin oils and virgin oils can be commercialised as they are for direct consumption. Ordinary virgin oils are commonly used mixed with refined olive oils and refined husk oils. Acid oils with an acidity higher than 3.3 degrees are usually refined.

The quality of the olive oil depends on the ripeness of the olives, the type of harvesting, e.g. picking or shaking, the type of intermediate storage, and the type of processing carried out. Olives contain 38–58 % oil and up to 60 % water. Ripe olives should be processed as quickly as possible since lipases in the pulp cause rapid hydrolysis of the oil, impairing its quality for edible purposes. Top-grade oils are made from fresh handpicked olives by size reduction, pasting and cold pressing. In the production of olive oil, there are three systems in use for the extraction of the oil: traditional, by pressing; three-phase separation; and two-phase separation.

In traditional production of olive oil, olives are ground into a paste with stone mills; however, these days modern milling equipment is also used. Milling is followed by mashing, possibly with the addition of salt. The pulp is then pressed and the press oil is clarified by sedimentation or centrifugation. Traditional open-cage presses are now being replaced by continuous screw expellers. The mashed pulp can also be separated in a horizontal decanter, in which case the crude oil is recentrifuged after the addition of wash water. Alternatively, machines can be used to remove the kernels from the pulp and the residue is then separated using self-discharging centrifuges. Cold pressing, which yields virgin grades, is generally followed by a warm pressing at approximately 40 °C. Cold-pressed olive oil is a valuable edible oil.

In Spain, most installations use the two-phase type centrifuges, while in most other Mediterranean countries larger installations use the three-phase technique and smaller installations typically still use traditional pressing. While the two-phase type generates a paste-like waste, both the traditional and the three-phase systems produce a liquid phase, i.e. olive mill waste water or alpechin, and a press cake known as pomace, husk or orujo. This latter product may be further treated as husk or pomace oil. The remaining solid husk is dried to 3–6 % humidity and used as fuel. Olive kernel oil is obtained by pressing and solvent extraction of cleaned kernels. It is similar to olive oil but lacks its typical flavour.

Trade specifications are based primarily on the FFA content and flavour assessment. In some countries, warm-pressed olive oil with a high acidity is refined by neutralisation, bleaching and deodorisation (see Section 11.2.2), and flavoured by blending with cold-pressed oil. The press cake contains 8–15 % of a relatively dark oil, called sanza or orujo, which can be extracted with hexane and is used for technical purposes. After refining, it is also fit for consumption.

Olive oil production has traditionally been one of the major sources of industrial pollution in the regions where it is carried out, e.g. in Andalusia, Spain. In traditional olive processing, i.e. the three-phase production, the extraction of the olive seeds has resulted in three streams, i.e. oily, aqueous and solid.

The oily stream is the virgin oil. It is produced at a rate of about 200 kg/t of olives if obtained using continuous separation by decanter centrifuges, or 150 kg/t using olive presses.

The aqueous waste, i.e. waste water, is sometimes called vegetable water and is highly polluted. Its volume depends on the technique applied but, in general, 1 m³ of waste water is produced per tonne of olives processed. The specific pollution is estimated to be about 65 kg BOD₅/t of olives processed. At the beginning of the 1990s, the resultant waste water during a 100-day

campaign represented about the same amount of water as Andalusia's total population's consumption for the whole year. At that time, only the classical presses and the three-phase continuous separation by decanter centrifuges were used.

The solid waste consists of two major parts, i.e. the stones or kernels and the crude oil cake/pomace. The stones accumulate in installations where destoned or stuffed table olives are produced. They can be used as fuel for heating, building materials or for activated charcoal. There is still a small amount of oil in the olive cake from the first pressing of the olives and this can be extracted. Its water content and composition depend on the extraction technique applied. If not going on for further processing, i.e. extraction, this cake is often used as fuel for heating, as an animal feed supplement or returned to the olive grove as a mulch to condition the soil.

In a technique implemented first in 1991-1992, the decanter centrifuges were modified so that the crushed (mixed) olives were separated into two phases, i.e. the oil phase and a solid phase. This technique does not require the addition of water to the olive mixture. By 2000, virtually all of the Andalusian olive oil mills had converted to the two-phase process.

Water is saved in the extraction part of the two-phase process. The amount of waste water and its contaminant load are also reduced. The water savings are particularly significant because olives are grown and processed in areas of very low rainfall. The rural settings of a significant proportion of the industry also means that there is little access to MWWTPs. However, the wetter solid output is also considered a problem comparable to the waste water produced from the three-phase process.

The solid output, i.e. spent olives or pomace (in Spanish 'alperujo'), is produced in greater amounts than from the three-phase process. After further hexane extraction, the spent olive cake is generated. This is often used as fuel for heating, as an animal feed supplement or returned to the olive grove as a mulch. The spent olive cake is normally dried before disposal. The energy requirement and the cost of the drying is higher and the drying is more difficult due to the higher water, polysaccharides and polyphenols content of the 'alperujo'. The continuous three-phase process generates spent olives with a moisture content of 35–45 %. With the continuous two-phase system, the spent olives present a moisture content of between 60 % and 70 % [105, RC/SPC 2000].

No water is used in the extraction part of the two-phase process and, as a result, there is no need to treat it. The amount and the pollutant load of the waste water are less. In the traditional process, the processing of 1 tonne of olives resulted in the production of about 0.6 m³ waste water with a BOD₅ emission level of 120 000–130 000 mg/l. The amount of waste water produced using the two-phase technique is about 0.15 m³/tonne of olives, with an average BOD₅ of 45 000–60 000 mg/l. As no water is used in the extraction, there are also savings in water consumption [105, RC/SPC 2000].

There are difficulties associated with the handling of the spent olive cake, which has a higher moisture content than the traditional cake and is not accepted by traditional extraction installations. It is also reportedly less profitable to extract the oil from it, due to its lower oil content, compared to the traditional or three-phase systems. Composting is reported to be an option in all cases. Use as biomass fuel is reported to be an option if a critical mass of spent olive cake is available, so not in cases of individual dispersed and isolated installations.

The throughputs of the two-phase and three-phase olive oil processes are compared in Table 12.1.

Table 12.1: Comparison of throughputs for the three-phase and two-phase olive oil processes

		Two-phase process	Three-phase process
Input	Olives (t)	1	1
	Water (m ³)	0.1–0.12 (rinsing water)	0.1–0.12 (rinsing water) 0.7–1 (water added)
Output	Oil (t)	0.2	0.2
	Waste water (t or m ³)	0.1–0.15	1–1.2
	Spent olives (t)	0.8	0.5–0.6
<i>Source:</i> [105, RC/SPC 2000]			

In the two-phase extraction of olive oil it is not necessary to add hot water. The energy consumption for both systems is reported to be < 90–117 kWh/t. Also, both systems use the same volume of washing water, i.e. 0.1–0.12 m³/t of olives. This water consumption is independent of the extraction process, although, in some cases, it gets mixed with the waste water or wet pomace from the extraction process. Some mills do not use washing water as they collect the olives directly from the trees.

Existing three-phase decanter centrifuges can be modified to two-phase operation. Pomace dryers originally used after three-phase extraction are unsuitable for drying the pomace produced using the two-phase technique. If the two-phase pomace is not dried under suitable conditions, the oil produced from it can contain PAH levels which could exceed those allowed under food safety legislation.

12.2.1 Olive-pomace oil refining

Olive-pomace installations process the olive-pomace remaining after the extraction of oil from the olives. Oil is extracted with solvents, resulting in crude pomace oil and exhausted husks. Oil is sent to refineries and later used in the food industry, while exhausted pomace is mainly used as fuel. Refined olive-pomace oils are mixed with virgin oils different from the lampante oils. It is also classified on the basis of denominations and definitions from Regulation 136/66/EEC [121, COM 1966].

12.2.2 Waste water treatment

Phosphorus is present in inorganic and organic form. Tests have been performed at the laboratory and pilot plant scale. Treatment strategies have been developed and as a result have been implemented in two prototype production-scale systems. Both examples are tailored to the special operating conditions of the installations and their local situation. Optimisation of the prototypes is still in progress.

Primary treatment used in the vegetable oil sector generally includes:

- flow and load equalisation (see Section 2.3.6.1.1);
- sedimentation (see Section 2.3.6.5.2);
- fat trap (see Section 2.3.6.1.4);
- DAF (see Section 2.3.6.5.4);
- precipitation (see Section 2.3.6.4.2), to reduce phosphorus emission levels.

Further secondary treatment is applied and aerobic processes are used (see Section 2.3.6.2.1). In general, the waste water is well suited to biological treatment. Activated sludge (see Section 2.3.6.2.1.1), trickling filters (see Section 2.3.6.2.1.5) and rotating biological contactors (see Section 2.3.6.2.1.7) can be used. Industry-specific factors that can influence biological waste water treatment are the presence of low-volatile lipophilic substances, sulphate, elevated phosphatide levels and a low pH.

12.2.2.1 Olive oil waste water

The olive mill waste water is considered one of the most polluting types of waste water in the FDM sector and causes great problems in the olive tree cultivation areas in Europe. It has a very high COD, i.e. 200 000 mg/l, a low pH, i.e. 3–5.9, and a high content of solid matter, i.e. TSS 20 000 mg/l. In addition, the high polyphenol content of olive oil waste water, up to 80 000 mg/l, makes bacterial degradation very difficult and gives it phytotoxic characteristics.

Usually, small olive mills, very many of which are below the IED threshold, use evaporation lagoons (see Section 2.3.6.2.1.2). Allowing their waste water to evaporate in open lagoons for months leads to stale odours and, in many cases, leakage causes groundwater contamination. The solid residue is then sent for landspreading. Direct deposition in olive groves can result in groundwater contamination. Connection to a MWWTP is not usually possible, as olive mills are normally in rural areas where MWWTPs either do not exist or are not designed to treat such waste water. Thermal concentration (not described in this document) can also be used to treat olive oil waste water.

Olive oil waste water can also be treated using an anaerobic WWTP, which can reduce COD emission levels by 65–95 %. This has a high investment cost, particularly because olive oil mills have seasonal harvesting; the campaigns are carried out between October and March and only last three months at each location. The seasonal characteristics of these mills do not affect the treatment as an anaerobic digester can be easily restarted after a dormant state, although it takes some time to re-establish treatment conditions.

The high polyphenol content of the waste water inhibits the growth of aerobic bacteria. In addition, the autoxidation of phenolic compounds during contact of olive oil waste water with air leads to the formation of macromolecular polyphenols which are even more difficult to degrade.

A further alternative treatment of waste water from olive mills can involve an effective primary treatment (see Section 2.3.6.1) to remove solids. Using precipitation (see Section 2.3.6.4.2), with the selection of an optimal flocculation agent, eliminates a very high percentage of the dissolved and particulate organic matter which will then be removed by filtration (see Section 2.3.6.5.3). The final step consists of applying membrane separation (see Section 2.3.6.5.4) to ensure 95 % reduction of the organic load. This is still under investigation but could be a solution for the future. Table 12.2 shows a comparison of treatment alternatives for olive oil waste water.

Table 12.2: Comparison of treatment alternatives for olive oil waste water

Method	Advantages	Disadvantages
Landspreading	Improved fertility because of K, Mg and organic matter content	Groundwater contamination High salinity Legal limitations Negative effects on vegetation if certain levels are surpassed due to polyphenol content
Evaporation lagoon	Low cost No specialised workers required	Large land surfaces needed Putrid odours and insects Groundwater contamination if the insulation of the basin is not correct
Thermal concentration	Faster system	High power consumption and cost Crust formation in the evaporators
Anaerobic processes	Low energy consumption Methane production Stabilised sludge	Expensive installation

Source: [71, AWARENET 2002]

12.3 Current consumption and emission levels

12.3.1 Energy consumption

Specific energy consumption values between 0.29 MWh and 13.11 MWh per tonne of products have been reported from three installations [193, TWG 2015].

12.3.2 Water consumption

Specific water consumption values between 2.16 m³ and 10.29 m³ per tonne of products have been reported by three installations (years 2012-2014) [193, TWG 2015].

12.3.3 Solid output

In crude olive oil production, the traditional system, i.e. pressing, and the three-phase system produce a press cake and a considerable amount of waste water while the two-phase system, which is mainly used in Spain, produces a paste-like waste called ‘alperujo’ which has a higher water content and is more difficult to treat than traditional solid waste. The water content of the press cake, composed of crude olive cake, pomace and husk, is about 30 % if it is produced by traditional pressing technology and about 45–50 % using decanter centrifuges. The press cake still has some oil which is normally recovered in a separate installation. The exhausted olive cake is incinerated or used as a soil conditioner in olive groves.

12.3.4 Emissions to water

Traditional olive oil production, also called pressing, generates about 2–5 litres of waste water per litre of oil produced, the three-phase continuous olive oil extraction generates about 6–8 litres of waste water per litre of oil produced, whereas the two-phase continuous olive oil extraction generates only about 0.33–0.35 litres of waste water per litre of oil produced. Table 12.3 shows the characteristics of olive oil waste water generated by different extraction techniques.

Table 12.3: Characteristics of olive oil mill waste water

Technology	Waste water volume (m ³ /t olive oil)	BOD ₅ (mg/l)	COD (mg/l)	TSS (mg/l)	pH
Traditional extraction (pressing)	2–5	22 000–62 000	59 000–162 000	65 000	4.6–4.9
Three-phase extraction	6–8	13 000–14 000	39 000–78 000	65 000	5.2
Two-phase extraction	0.33–0.35	90 000–100 000	120 000–130 000	120 000	4.5–5.0

Source: [42, Greek Ministry for the Environment 1997], [50, Junta de Andalucía and Agencia de Medio Ambiente 1994]

In Table 12.4, average volumes of waste waters generated in different steps of the two- and three-phase olive oil extraction processes are presented. In Table 12.5, data on composition of waste waters generated in different steps of the two- and three-phase olive oil extraction processes are presented.

Table 12.4: Volumes of olive oil waste waters from the two- and three-phase extraction processes

Effluent	Volume (l/kg olives processed)	
	Two-phase process	Three-phase process
Washing of olives	0.05	0.09
Horizontal centrifuge	0	0.90
Washing of olive oil (vertical centrifuge)	0.15	0.20
General cleaning	0.05	0.05
Final effluent	0.25	1.24
<i>Source: [33, Borja et al. 2006]</i>		

Table 12.5: Compositon of olive oil waste waters from the two- and three-phase extraction processes

Effluent	Two-phase process			Three-phase process		
	Solids (%)	Oil (%)	COD (g/kg olives processed)	Solids (%)	Oil (%)	COD (g/kg olives processed)
Washing of olives	0.54	0.1	0.87	0.51	0.14	7.87
Horizontal centrifuge	0	0	0	6.24	0.96	73.82
Washing of olive oil (vertical centrifuge)	1.43	0.57	1.17	0	0	0
Final effluent	2.82	0.29	2.25	4.86	0.31	68.61
<i>Source: [33, Borja et al. 2006]</i>						

More information on emissions to water can be found in Section 2.2.3.

12.4 Techniques to consider in the determination of BAT

12.4.1 Techniques to reduce emissions to air

12.4.1.1 Production of olive-pomace oil

12.4.1.1.1 Mineral oil scrubber to recover hexane

See Section 11.4.2.4.4.

12.4.1.1.2 Hexane recovery using a reboiler and gravity separator

See Section 11.4.2.4.5.

13 SOFT DRINKS AND NECTAR/JUICE MADE FROM PROCESSED FRUIT AND VEGETABLES

13.1 General information about the sector

The soft drinks category comprises still drinks, squashes, carbonates, iced teas and coffees, syrups, dilutables, energy drinks and sports drinks. Some 50 million litres of soft drinks are sold in Europe annually. This comprises both full sugar and no- and low-sugar drinks which represent an increasing share of the market – up to 40 % of total sales in some countries.

Soft drinks sales in Europe have an annual retail sales value of some EUR 93 billion. A total of 57 % of retail sales by value are through the on-trade (hotels, restaurants, bars) and 43 % of retail sales by value are through the off-trade (shops and supermarkets). In volume terms, 17 % of sales go through the on-trade and 83 % through the off-trade.

The European soft drinks sector and its value chain have a significant impact on the European economy. The industry value chain reverberates across agriculture, raw materials, manufacturing, packaging, transport, retail and catering. Ingredients such as fruit and sugar are sourced from Europe's agricultural sector. Citrus fruits are bought from hundreds of growers in countries in the south of Europe such as Spain, Italy and Greece and berries are supplied from many of the EU-28 MS. Sugar beet is sourced across Europe including from France, Germany, Poland and Belgium. Water is a primary ingredient in beverages and most soft drinks, including regular and no- and low-calorie sparkling beverages, are between 85 % and 95 % water.

The bottling process supports many thousands of suppliers and the distribution sector transports soft drinks products across the continent to their final destinations, servicing shoppers and clients in bars, restaurants and retail outlets.

Research by global soft drinks industry analysts estimates that the soft drinks sector delivers an overall added value of EUR 55.4 billion. Of this, 17 % (EUR 9.2 billion) is contributed directly by soft drinks producers including salaries, tax payments and profits within the EU-28. The other 83 % (EUR 46.2 billion) is contributed indirectly up and down the value chain including ingredients, packaging suppliers, distribution, advertising, marketing and retail.

The EU Member States are key beneficiaries of the soft drinks industry added value. They receive at least EUR 22.3 billion from labour taxes and VAT associated with the industries' products and households in the industry's supply chain received over EUR 25 billion in the form of incomes after taxes.

The European soft drinks industry is rooted in the European economy and its economic footprint thrives on its strong connections with other sectors. It supports over 1 million jobs across the EU-28. A total of 156 000 people are employed directly in the industry and a further 890 000 jobs are supported throughout the EU economy. Each worker employed by the soft drinks industry supports another six workers in the European value chain. Some 20 000 of these jobs are in agriculture and ingredients production, 32 000 in packaging, 39 000 in the transport sector, 27 000 jobs in services such as advertising and design, 180 000 jobs in shops and supermarkets and 596 000 jobs in bars and restaurants across Europe. A total of 0.43% of the EU-28 workforce relies on the soft drinks industry for employment.

The industry is generally a local industry with production, sales and distribution taking place close to the consumer. It has a strong footprint across Europe with over 1 070 production facilities and bottling plants across the continent, operated and staffed locally to supply local customers and markets. This generates income for bars, restaurants and supermarkets in every town and city.

In some countries, especially in northern Europe, soft drinks are often produced in the same plants that produce beer and other mild alcoholic beverages, e.g. breweries. Therefore, some processes, especially filling of the beverages, but also processes related to process hygiene, cleaning, energy economy and maintenance might be very integrated. Consequently, the allocation of production inputs and emissions by type of product is very challenging.

13.2 Applied processes and techniques

Soft drinks can be categorised into two main types, i.e. carbonated and still. Soft drinks include fruit-, vegetable- and juice-based drinks such as cordials, squashes and barley water; flavoured drinks such as ginger beer; tonic water and lemonades; as well as infusions such as tea.

Ingredients typically found in most soft drinks include water, sweetener, acid and flavourings. Optional ingredients include fruit, vegetables, carbon dioxide, preservatives and colour. Water is the main ingredient of all soft drinks and, as such, the quality of the water, in terms of its microbiological loading and other parameters which affect the final sensory qualities of the drink, are of paramount importance. Most soft drinks are sweetened with natural sweeteners such as sugar and sugar syrups, and/or intense sweeteners such as saccharin and aspartame. Flavourings used in manufacture are often derived from highly concentrated liquid mixtures of plant extracts such as fruit, flowers, seeds, leaves, bark and root. Alternatively, they may be synthetic.

All sparkling soft drinks require the addition of carbon dioxide. This may be sourced as a co-product from the petroleum, beer and whisky industries, or produced on site. The preservation of soft drinks can be achieved by a number of techniques including heating, chemical preservation and filtration. These methods, in combination with low pH, prevent microbiological spoilage.

The aim of carbonation is to dissolve a quantity of carbonic gas into different products to obtain a gasified or carbonated final product. When dissolved in water, carbon dioxide (CO₂), is sparingly soluble and thus slowly released, forming bubbles that provide a characteristic mouthfeel and a unique taste when consumed. In addition to an organoleptic property, under suitable conditions, CO₂ has a preserving property by the inhibition of the development of harmful aerobic microorganisms.

A carbonator combines CO₂ gas with the liquid to be carbonated. Carbonators can be classified into two main categories; those that carbonate water only and those that carbonate the finished product mixture of syrup and water. These are sometimes coupled with coolers, often referred to as carbo-coolers. The principal designs available are carbonators with integral coolers, draining wall heat exchangers and carbon dioxide injectors.

In combination with this process, de-aeration, i.e. the removal of air, is vital and is usually applied to the water component in a first stage. The presence of air can create spoilage problems. CO₂ is sometimes used to flush out air; however, the use of mechanically de-aerated water has become more popular in recent years.

The degree of carbonation varies for each soft drink formulation, from 4 g/l in fruit drinks to 9 g/l in mixer drinks and 12 g/l in soda water. The CO₂ gas content is one of the smallest constituents by weight, but possibly the most important with regard to the palatability of the product. CO₂ is one of the very few gases suitable for providing the effervescence in soft drinks; it is non-toxic, inert, and virtually tasteless and allows for convenient bulk transportation and storage.

The basic processes for the manufacture of soft drinks also involve the mixing of ingredients in the syrup room, followed by the addition of water that has been subjected to various water treatments. The mixture may be heat-processed or chemically preserved at this stage. The product is carbonated if required. Alternatively, after the syrup and water are combined, the product may be filled into packaging and in-pack heat-processed. Syrups may require filtration or homogenisation and may be pasteurised. Most packaging is cleaned prior to filling, either by rinsing with water, possibly containing rinsing aids, or by air blasting.

13.3 Current consumption and emission levels

13.3.1 Energy consumption

Figure 13.1 shows data on specific energy consumption (MWh/hl of products) in various soft drinks and nectar/juice installations. According to the received data, specific energy consumption values below 0.035 MWh/hl of products have been reported.

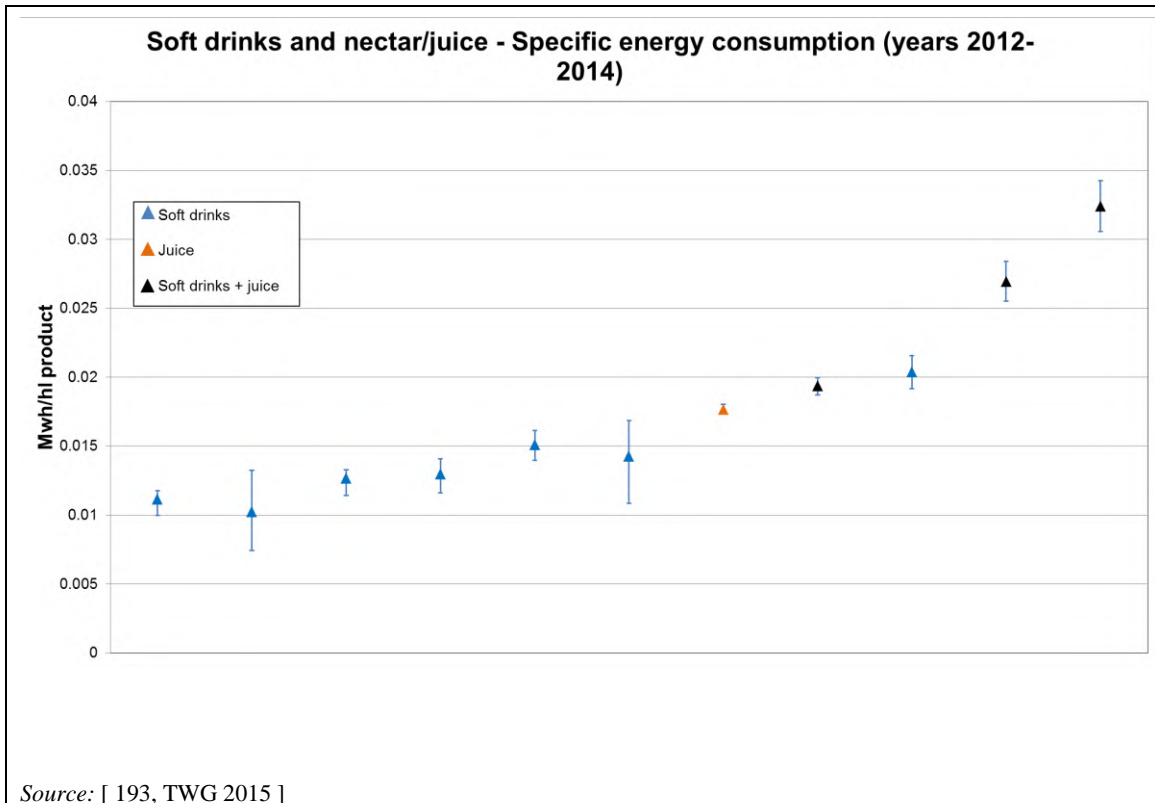

Figure 13.1: Specific energy consumption (MWh/hl of products) in soft drinks and nectar/juice production

13.3.2 Water consumption

Figure 13.2 shows data on specific water consumption (m^3/hl of products) in the various soft drinks and nectar/juice installations. According to the received data, in most cases specific water consumption values below $0.3 \text{ m}^3/\text{hl}$ of products have been reported.

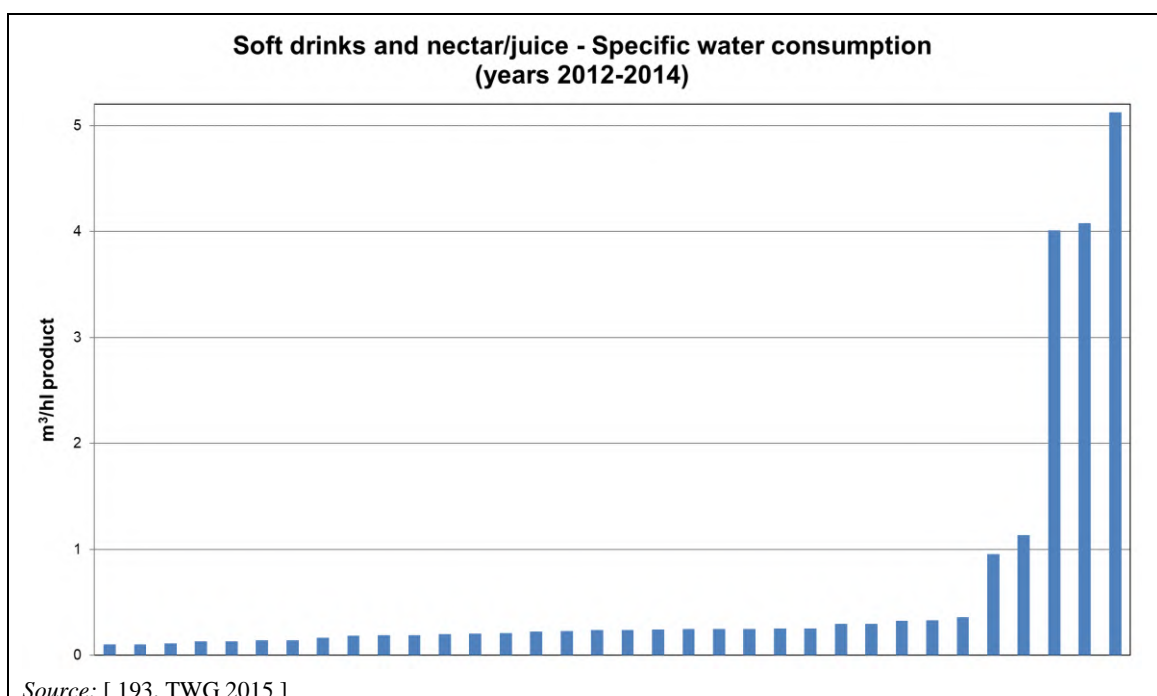

Figure 13.2: Specific water consumption (m^3/hl of products) in soft drinks and nectar/juice production

13.3.3 Emissions to water

Figure 13.3 shows reported data on specific waste water discharges (m^3/hl of products) from soft drinks and nectar/juice installations and all types of discharges. More information on emissions to water can be found in Section 2.2.3.

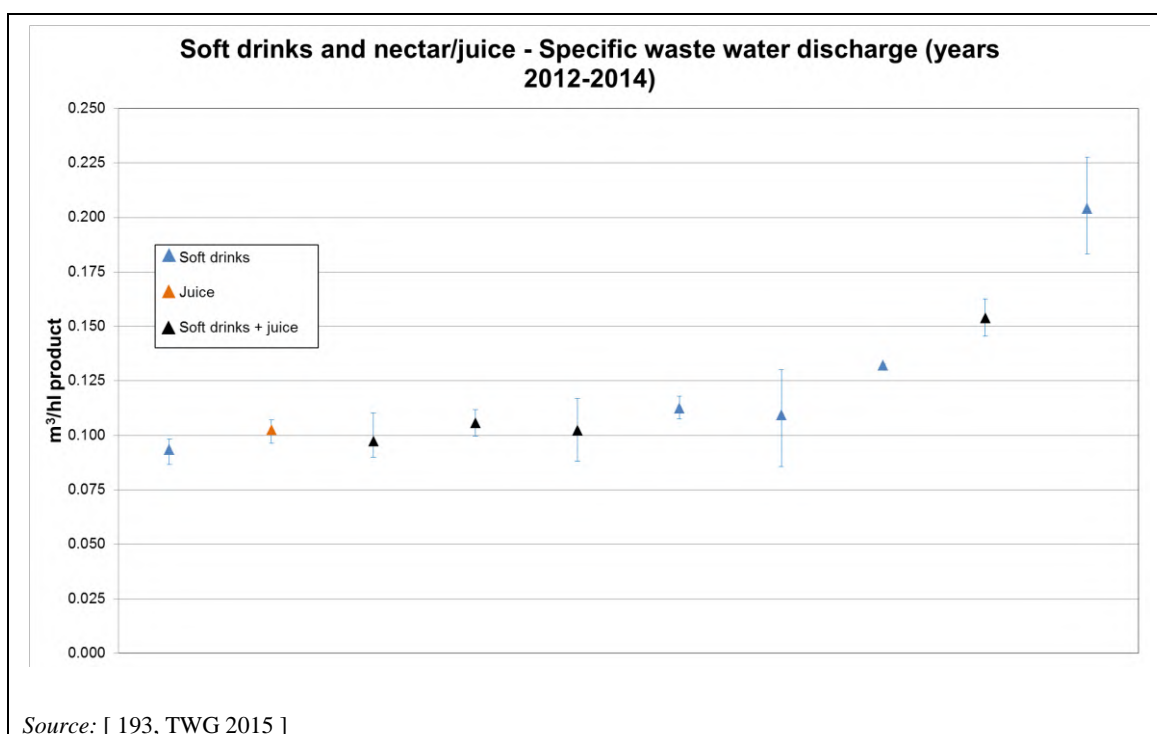

Figure 13.3: Specific waste water discharge (m^3/hl of products) in soft drinks and nectar/juice production for all types of discharges

13.4 Techniques to consider in the determination of BAT

13.4.1 Techniques to increase energy efficiency

13.4.1.1 Application of a negative pressure for mixing purposes

Description

A negative pressure is created which forces fluids to be emptied from containers or powder to be added into the mixer.

Technical description

A negative pressure is created which is the driving force to empty fluids from containers or to add powder into the mixer. Beverage powders are often easily dissolved and do not require the same amount of energy as powders like gums, which need a high-shear mixer in order to be mixed.

Achieved environmental benefits

Reduced energy consumption compared to high-shear mixers.

Environmental performance and operational data

For example, with a 7.5 kW mixer for a 3 000-litre mixing tank, fluids of less than 200 cP can be emptied from a barrel. A total of 7.5 kW of electric power would be needed with a radial jet mixer, compared to 18 kW in the case of a high-shear mixer. Powder mixing does not work well with excessively viscous powders like stabilisers.

With this technology, powder can be transported long distances, it can be kept outside a building and the machine does not require ATEX certification. This results in a safer production facility for an installation handling powder.

Cross-media effects

No information provided.

Technical considerations relevant to applicability

The technique is applicable in beverage installations, in the mixing area. For viscous powders like stabilisers, there is a need to add another technique, such as high-shear mixing.

Economics

No information provided.

Driving force for implementation

- Less risk of explosion when this technology is used for hydraulic transportation.
- Ergonomic solution for operator since operation at floor level is possible.

Example plants

This technique is generally used worldwide.

References

[189, Tetra Pak 2015]

13.4.1.2 Single pasteuriser for nectar/juice production

Description

Use of one pasteuriser for both the juice and the pulp instead of using two separate pasteurisers.

Technical description

Normally two pasteurisers are used, one for liquid and one for the slurry containing particles or fibres (dual-line solution). The single-line solution eliminates one pasteuriser (the slurry pasteuriser). In the single-line solution, the particles are dosed in-line in the middle of the main pasteuriser and the whole volume is pasteurised once (see Figure 13.4).

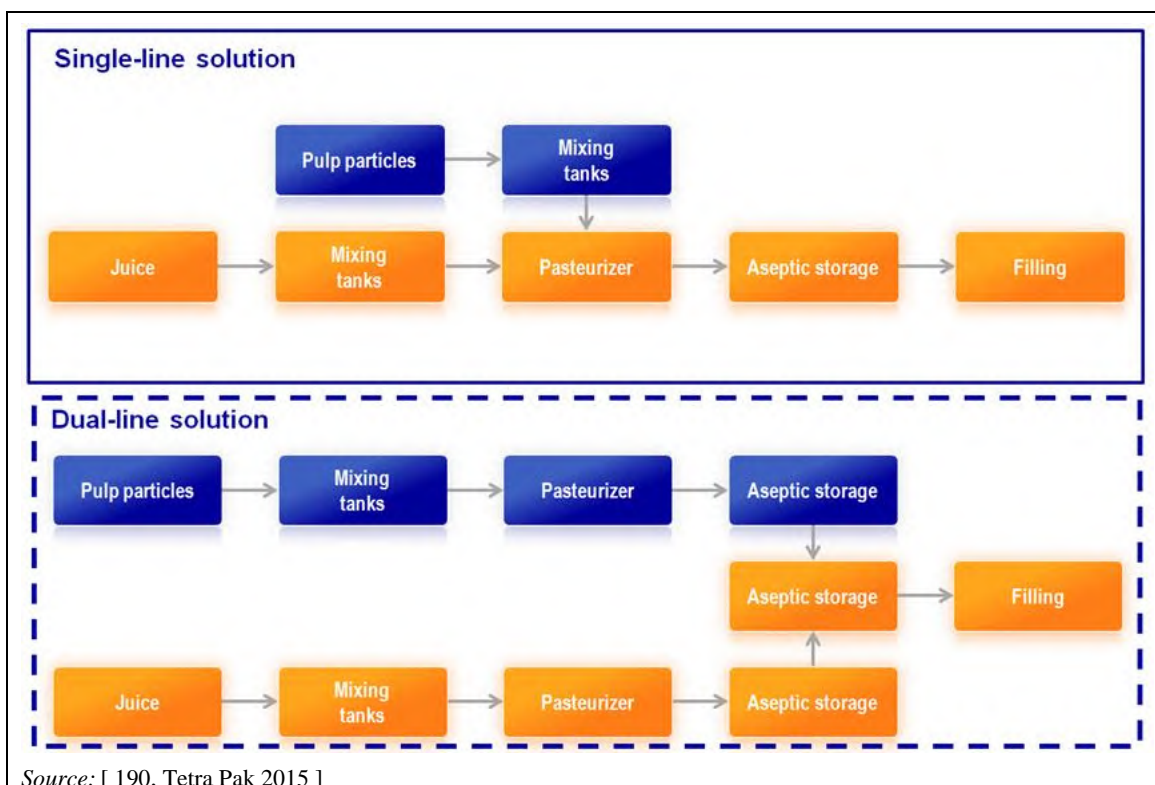

Source: [190, Tetra Pak 2015]

Figure 13.4: Comparison between single- and dual-line solution

Achieved environmental benefits

Reduced energy consumption (heating and cooling).

Environmental performance and operational data

The slurry contains 35–40 % particles and the final beverage around 5 % particles, which means that the slurry represents approximately a seventh of the total volume. The recirculated slurry in the slurry pasteuriser in the dual-line solution is not more than 50 % (sometimes even zero) due to high pressure drops. For the final beverage pasteuriser, the recirculated slurry is about 85 %. In a dual-line solution $(85-50)/7 = 5\%$ recirculated slurry is lost. This means that the energy loss in the single-line solution is 15 % compared to 20 % for the dual-line solution. The result is that the single-line solution consumes 25 % less heating and cooling energy.

Cross-media effects

No information provided.

Technical considerations relevant to applicability

The applicability may be restricted due to the pulp particle size.

Economics

No information provided.

Driving force for implementation

Reduction of energy costs. Possibility to de-aerate and homogenise the continuous liquid phase.

Example plants

This technique has been implemented in some installations in Turkey and Nigeria.

References

[190, Tetra Pak 2015], [198, FoodDrinkEurope 2015]

13.4.1.3 Hydraulic sugar transportation

Description

Sugar is transported to the production process with water. As some of the sugar is already dissolved during the transportation, less energy is needed in the process for dissolving sugar.

Technical description

With a hydraulic injector, the sugar dissolver already starts to dissolve the sugar in the sugar store. Since this can be far away, this technique allows a lower sugar dissolution temperature due to the fact that the sugar has a longer dissolution time than in other conventional systems. The energy required is not just used for conveying but also initiates a pre-dissolution process, which means that this energy is not lost. This reduces the amount of energy required, compared to mechanical and pneumatic conveying systems, in order to dissolve sugar continuously. If a pasteuriser is added to the sugar dissolver, a better regenerative (energy recovery) is created by having a lower sugar dissolution temperature. This produces a reduction of cooling water consumption.

Achieved environmental benefits

Reduction of dissolution temperature which leads to a lower energy consumption.

Environmental performance and operational data

As an example, for a capacity of 10 000 l/h, a conventional system for continuous dissolution requires 31 °C for 62 °Bx, which means 168 kW. A continuous dissolution system with a hydraulic injector requires 22 °C for 62 °Bx, which means 89 kW.

Cross-media effects

There are no cross-media effects associated with this technique.

Technical considerations relevant to applicability

The technique can be applied in sugar treatment, producers of sugar solution and beverage producers who want to produce sugar solution for their beverages (soft drinks, juice, etc.).

Economics

No information provided.

Driving force for implementation

- Reduced energy costs.
- Safe working environment due to the powder being placed outside the factory.

Example plants

This technique has been implemented worldwide.

References

[191, Tetra Pak 2015]

13.4.1.4 Energy-efficient homogeniser for nectar/juice production

Information on this technique is available in Section 5.4.2.2.

13.4.1.5 Use low-pressure blowers for bottle drying

Description

Low-pressure air blowers are installed for bottle drying application. Elimination of air knives usually installed for drying applications in bottling lines and substitution by blowers is a good practice for energy efficiency.

Technical description

Blowers are much more efficient than air knives in terms of operation and maintenance.

Air knives are commonly used to remove straws from returned bottles and water droplets from finished packages. These small nozzles use a low volume of high-pressure air and are very expensive to operate (compressed air is one of the most expensive energy sources). A much more efficient alternative is to use high volumes of low-pressure air from blower systems that use motor-driven fans as opposed to compressors. Blower equipment is also far less expensive to maintain.

Achieved environmental benefits

Standard air knives use 35 m³/h each of compressed air, which requires 3 kW per air knife.

Environmental performance and operational data

No information provided.

Cross-media effects

The bottle drying operation may take longer (than air knives) in some plants.

Technical considerations relevant to applicability

Typically the blower assembly is mounted on the floor or platform with distribution hoses that supply air to multiple nozzle assemblies. A knowledgeable vendor should be consulted to ensure that the systems are properly sized.

Economics

For a typical setup using six air knives, substitution by a blower system can save EUR 9 000/year assuming 5 000 h/year of operation and an electricity cost of EUR 0.10/kWh. The average payback time is 2 years or less.

Driving force for implementation

Lower operating costs will be achieved due to the lower air pressure (lower energy usage).

Example plants

An installation in Spain.

Reference literature

[98, TWG 2017]

13.4.2 Techniques to reduce water consumption

13.4.2.1 Water recycling

See also Section 2.3.3.1.1.

Description

Recycling or reuse of water streams (preceded or not by water treatment), e.g. for cleaning, washing, cooling or for the process itself.

Technical description

Water from the rinsing process goes directly to a store tank and, after possible treatment, can be used for auxiliary services. Moreover, waste water from the fillers can be used for cooling purposes.

Achieved environmental benefits

Reduction of water consumption.

Environmental performance and operational data

In an example installation (#183), rinsing water goes directly to the store tank and, after being filtered, it goes through decalcification resin equipment and is reused for auxiliary services. A 25 % reduction of water consumption in auxiliary services is achieved.

In another installation (#279), waste water from the fillers (which is close to being clean water, COD around 100 mg/l) is reused in the cooling towers. This cooling system needs around 150 m³ water a day to be efficient. The waste water has to be treated correctly with biocides in order to be reused in the cooling towers.

Cross-media effects

Increased energy consumption due to the pumping system.

Technical considerations relevant to applicability

No information provided.

Economics

An investment cost of EUR 140 000 and an annual operating cost of EUR 9 300 have been reported (for a storage tank of 10 m³).

Driving force for implementation

Reduced of costs associated to waste water treatment.

Example plants

Installations #183 and #279.

Reference literature

[193, TWG 2015]

13.4.3 Techniques to reduce waste

13.4.3.1 Separation of residues

This technique is described in Section 2.3.5.3.

There are likely to be many other opportunities to apply this technique within the sector.

Some examples from the drink manufacturing sector are the following:

- clarification involves the addition of fining agents; it is reported that sediments from clarification are segregated by centrifugation or filtration;
- waste water with a high sugar/fermentable content can be reused in other industries, e.g. for yeast production;
- returning strong liquors to the process, or recovering them for animal feed or other reuse;
- collecting the contents from returned containers rather than washing them to drain.

Technical considerations relevant to applicability

Applicable to all drinks manufacturing installations.

Reference literature

[71, AWARENET 2002]

13.5 Emerging techniques

13.5.1 Optimised juice pasteurisation

Description

Optimised juice pasteurisation.

Technical description

Juice pasteurisation is conducted in two steps. The first pasteurisation, commonly conducted immediately after the juice is squeezed, deactivates enzymes and kills microorganisms. Prior to the packaging, another pasteurisation is conducted to destroy microorganisms developed during bulk storage. This second process is usually conducted at a temperature of 95 °C for 15 seconds. With new technologies introduced, the temperature of this process is brought down to 80 °C for juices with a pH level at or below 4.2.

Achieved environmental benefits

Up to 20 % reduction in energy consumption.

Environmental performance and operational data

An example of energy savings is shown in Table 13.1.

Table 13.1: Comparison of heat treatment processes for pasteurisation

Second pasteurisation	95 °C (15 s)	80 °C (15 s)
Heating load (kW)	430	354
Cooling load (kW)	183	107
Energy cost (EUR)	99 000	80 000
CO ₂ emissions (kg CO ₂ /1 000 litres)	6.7	5.4
⁽¹⁾ Capacity of 22 000 l/h. Operation 4 000 h/year. Steam cost: EUR 0.035/kg. Cooling cost: EUR 0.025/kWh.		

Cross-media effects

No information provided.

Technical considerations relevant to applicability

Generally, there are no technical restrictions to the applicability of this technique in installations producing juice, nectar and still drinks.

Economics

No information provided.

Driving force for implementation

Reduced operational cost.

Example plants

Several installations worldwide are looking at this solution and carrying out their own tests. A Danish producer is close to starting to use it.

References

[187, Tetra Pak 2015], [188, Tetra Pak 2015]

14 STARCH PRODUCTION

14.1 General information about the sector

Starch is a high molecular mass carbohydrate produced naturally by plants as an energy reserve. Starch and its derivatives are used in several sectors including food, feed, paper and board, textiles, pharmaceuticals and cosmetics. Native starch is usually a white powder. Starch and its derivatives can be used for thickening, binding, gelatinising, colouring, anti-crystallising and for sweetening in the food industry. Physically or chemically treated or modified starches are produced to specifically enhance some functional properties. Hydrolysis of starch by acid or enzymes yields a variety of sugar syrups called liquid sweeteners (e.g. liquid glucose, glucose-fructose syrups), which can also be dried and used in confectionery, drinks, baby food, dairy, baked products or other foods. Incomplete hydrolysis yields a mixture of glucose, maltose and non-hydrolysed fractions. Germ is a co-product of the manufacture of starch and can be used to produce oils. Other co-products are fibre, gluten and de-fatted meal which are all used or sold on for other uses, including animal feed. Other products can also be produced in starch installations, such as polyols and ethanol.

The main raw materials used in Europe for the production of starch and its derivatives are cereals, i.e. maize, wheat, barley and rice, and potatoes of dedicated varieties. Each installation is usually technically focused on one raw material [6, Environment Agency of England and Wales 2000], [48, European Starch Association 2001].

The European starch industry produces over 600 products, from native starches to physically or chemically modified starches, through to liquid and solid sweeteners. The versatility of starch products is such that they are used as ingredients and functional supplements in a vast array of food, non-food, and feed applications. From around 77 starch production facilities in 21 of the 28 EU Member States, the European starch industry produces 10.5 million tonnes of starch each year from EU wheat, maize and potatoes (see Figure 14.1). EU starch production increased from 8.7 million tonnes in 2004 to 10.5 million tonnes in 2014 (see Figure 14.2).

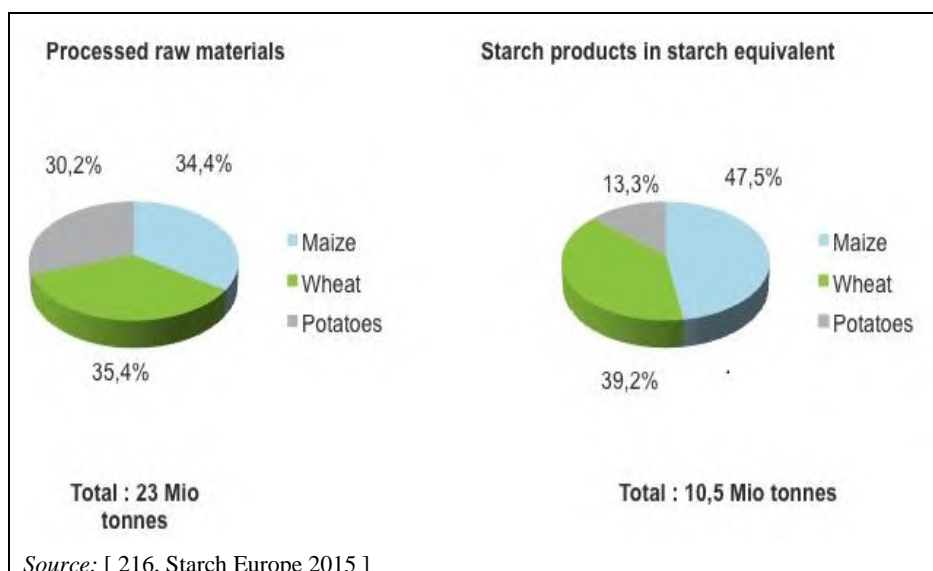

Figure 14.1: Starch production in the EU-28 (2014)

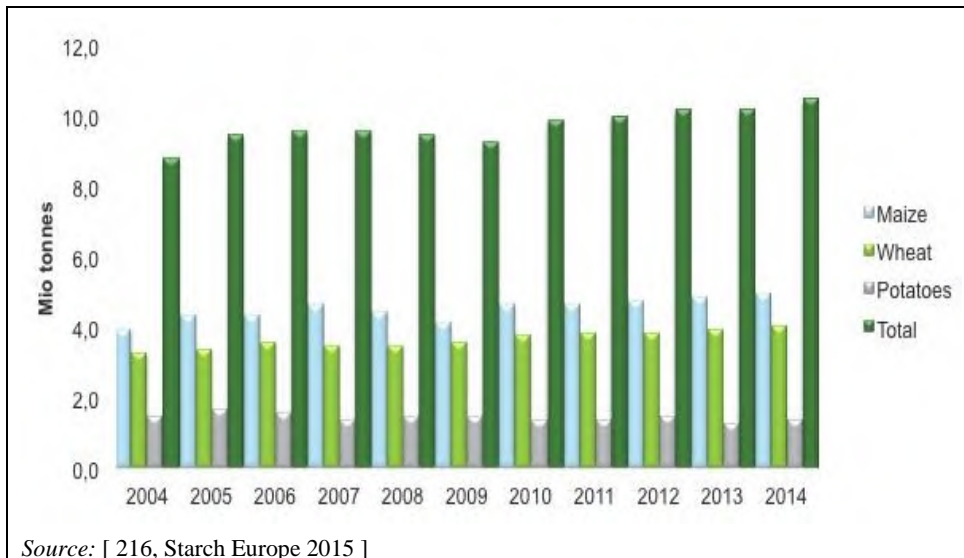

Figure 14.2: Starch production in the EU-28

The EU-28 consumes 9 million tonnes of starch (excluding starch by-products totalling around 5 million tonnes), of which 61 % is in food, 1 % in feed and 38 % in non-food applications, primarily papermaking (see Figure 14.3). Of the 9 million tonnes of starch and starch derivatives consumed in the EU, 25 % are native starches, 20 % modified starches and 55 % starch sweeteners.

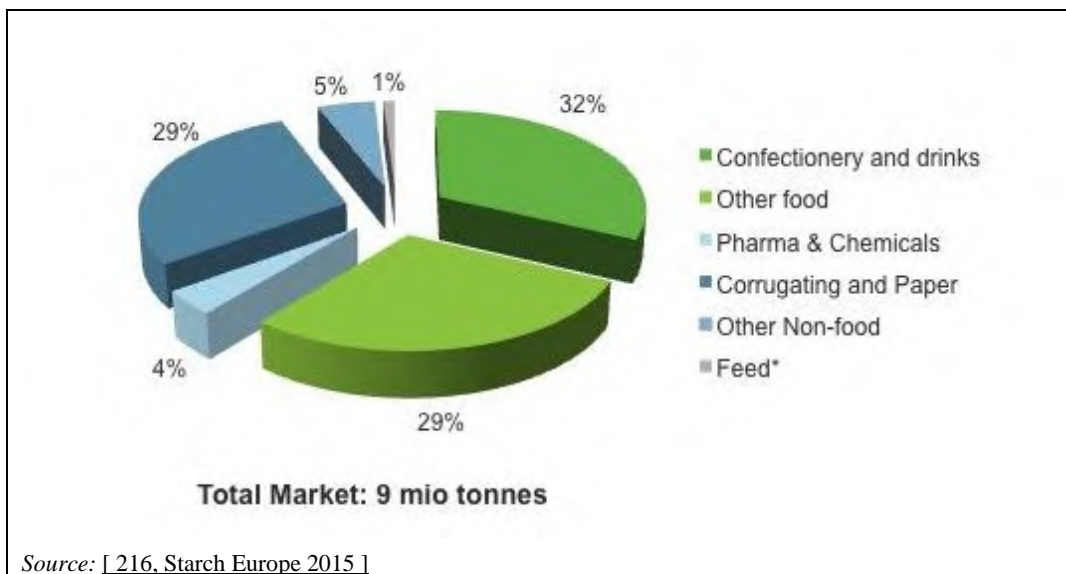

Figure 14.3: Main starch applications in the EU-28 (2014)

Only starch (and derivatives) production from maize, wheat and potatoes is described in this document.

14.2 Applied processes and techniques

The starch industry separates the components of the plant: starch, protein, cellulose envelope, soluble fractions and, in the case of maize, the germ from which oil will be extracted. This first phase utilises a series of simple stages of physical separation of the components: crushing, sifting, centrifuging, etc. However, the methods of manufacture are specific to each installation and the industrial tools are normally dedicated to a specific raw material (maize, wheat or potato in Europe). In the second stage, the starch, which has been extracted in its purest form, will be used as it is after drying (this is called native starch) or it will be further processed, undergoing various transformations aiming either at modifying its performance (modified starch) or to obtain sweeteners through the process of hydrolysis. At the end of the process, the starch and derived products are delivered to customer industries in the form of powder (with an appearance similar to that of flour) or of syrups. A general overview of the starch production process is shown in Figure 14.4.

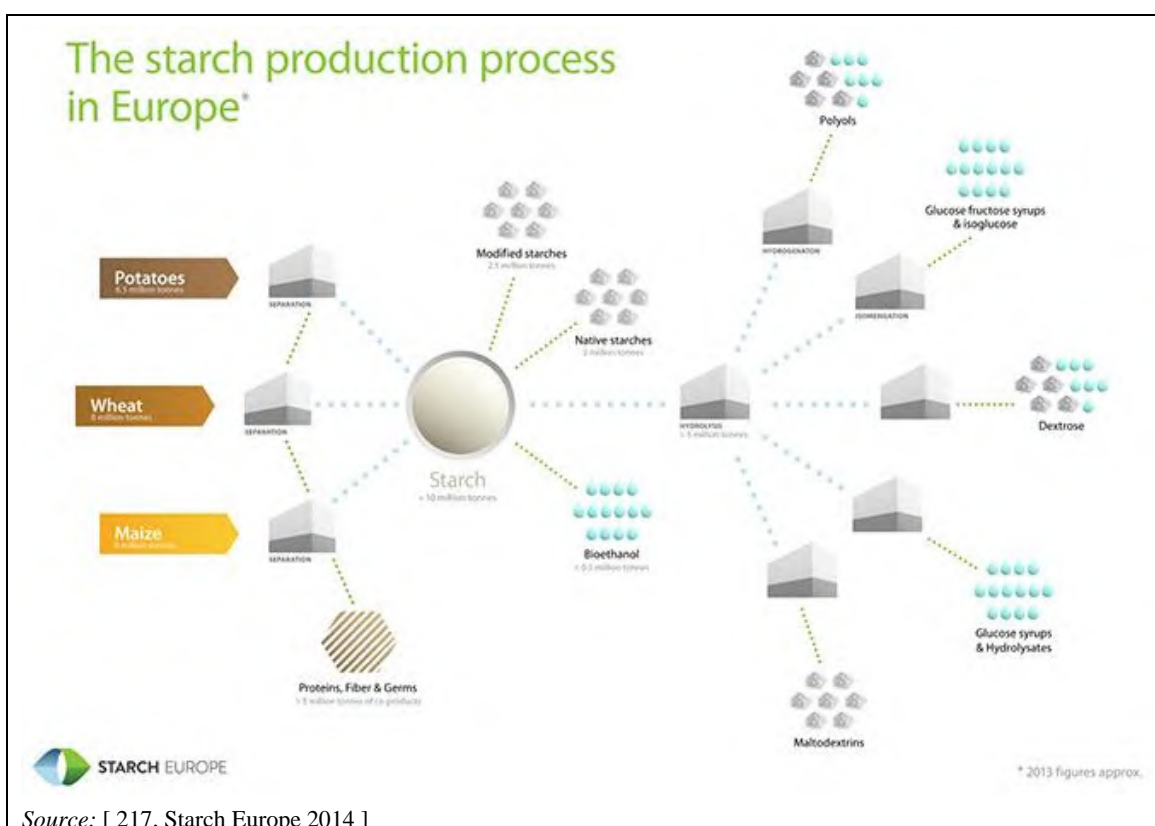

Figure 14.4: Starch production process

14.2.1 Maize starch

The commercial separation of pure starch from maize is achieved by a wet milling process which is generally considered to be efficient. The process is operated as an enclosed system in which process water is reused in a closed circuit. The addition of fresh water is limited to one point in the production process.

The raw material is washed using aspiration and screening to remove dust, chaff, broken grain, cobs and other extraneous material. The maize is soaked in water for around 36 hours, in a process known as steeping, possibly using sulphurous compounds. This removes solubles in the maize, softens the kernel to improve separation of the various components and reduces microbial activity. After steeping, the maize is passed through several grinding and separation operations until only starch and gluten remain. The grain is first ground coarsely and the germ is

removed from the coarse grist. After removing the germ, the grist is finely ground and fibre is removed through a screening operation. Starch and gluten are separated, typically using centrifugal methods. This raw starch is washed with drinking water, using a countercurrent flow, in a series of four to six centrifuges. At one end, raw starch is the input and process water is the output and, at the other end, refined starch is the output and fresh drinking water is the input. The starch, which at this stage is called refined starch, is then dewatered and dried. Refined starch is typically 99 % pure and 85–88 % dry solids. Native starch is refined starch, before physico-chemical modification. The gluten and fibre are collected separately as co-products. An example of a general overview of the maize starch production process is shown in Figure 14.5.

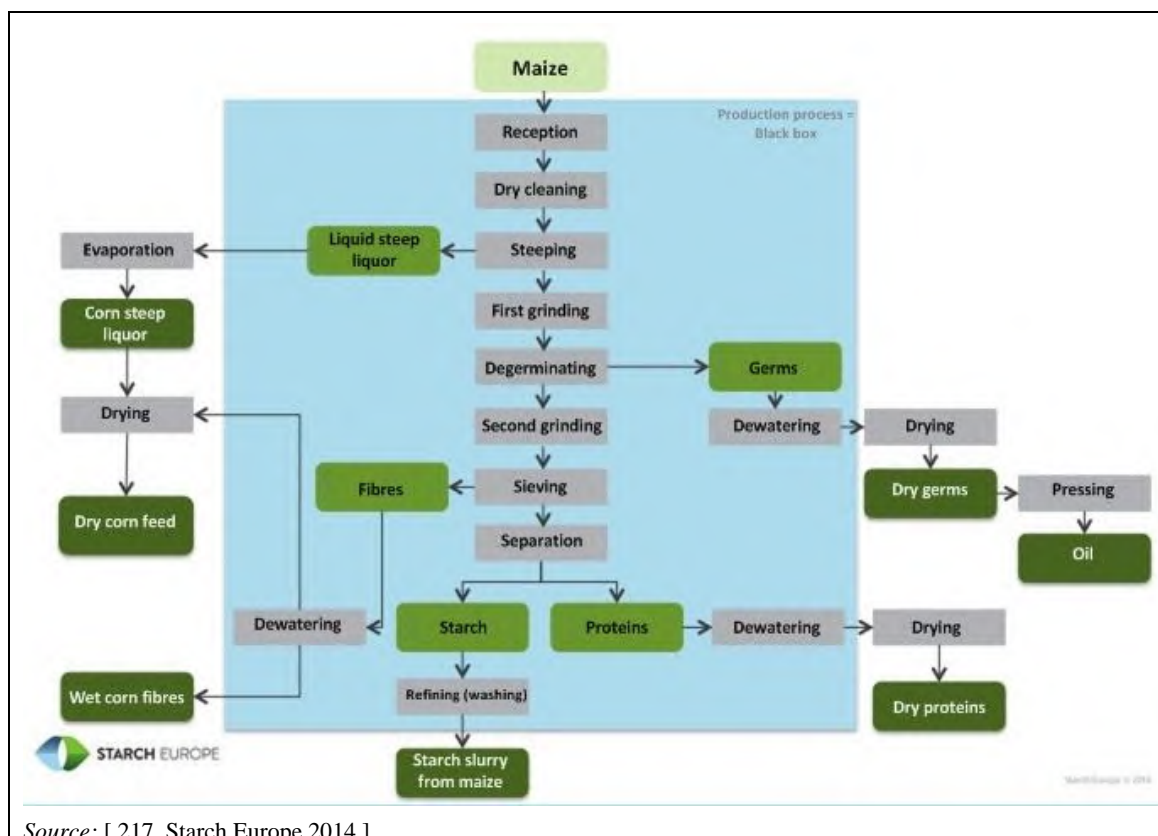

Source: [217, Starch Europe 2014]

Figure 14.5: Maize starch production process

14.2.2 Wheat starch

The commercial separation of pure starch from wheat is achieved by a two-phase process. In the first phase, the wheat kernel is ground or converted into wheat flour by a dry milling process. The second phase then separates the ground wheat or the wheat flour into its separate components, i.e. starch, gluten, solubles and eventually fibre, by a wet separation process. The process is operated as an enclosed system in which process water is recycled in a closed circuit. Fresh water is used at some stages of the process. A general overview of the wheat starch production process is shown in Figure 14.6. The process of washing raw wheat starch to produce refined starch is the same as that for maize starch (see Section 14.2.1).

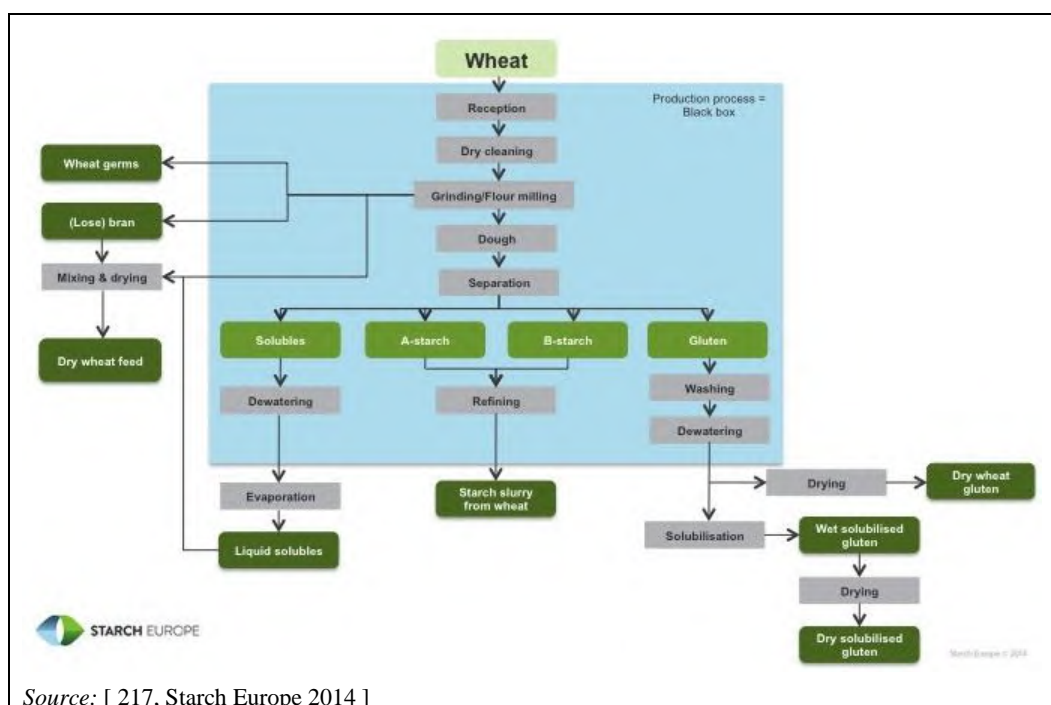

Figure 14.6: Wheat starch production process

14.2.3 Potato starch

Starch is extracted from potatoes by a wet process. This involves the disintegration of the tuber, from which the starch slurry is separated before being refined, dewatered and dried (or processed further). Final products include starch, proteins, pulp, fibres and fruit juice. A general overview of the potato starch production process is shown in Figure 14.7. The process of washing raw potato starch to produce refined starch is the same as that for maize starch (see Section 14.2.1).

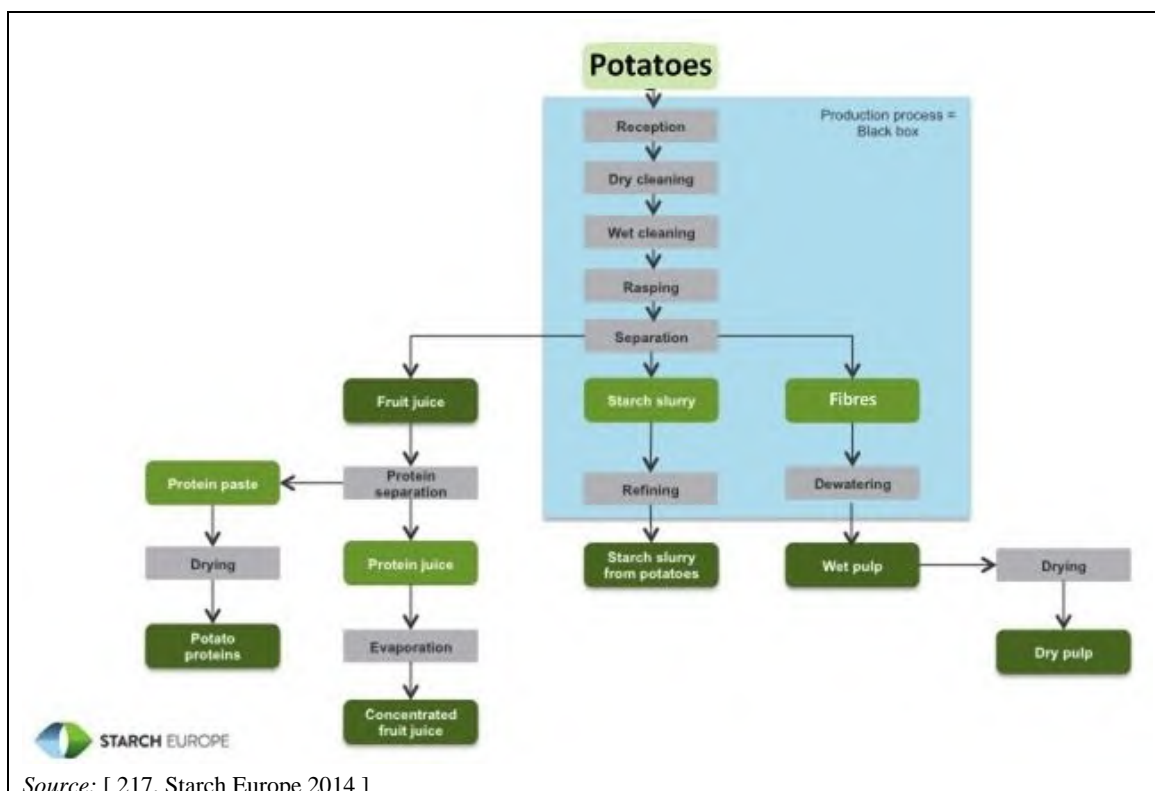

Figure 14.7: Potato starch production process

In some MS, e.g. Belgium and the Netherlands, potato starch is produced in integrated plants (e.g. also producing fries or purée products).

14.2.4 Sweeteners

Starch slurry is the starting raw material for the manufacture of starch-based sweeteners. These are produced by the action of acids, enzymes or a combination of both; however, enzymes are more commonly used. In a typical process, the starch slurry is heated to gelatinise the starch and then mixed with acids and/or enzymes and reacted in different liquefaction reactors. Conversion of the starch only takes a few minutes. The mass is neutralised and, after additional enzymatic reactions such as saccharification and/or isomerisation, several stages of purification take place, i.e. separation of insolubles, demineralisation and decolourisation, before the product obtained is evaporated. The liquor is usually filtered and treated with activated carbon or ion exchange resins to remove colour, ash and other minor impurities, e.g. minerals. The resulting liquid sweetener can be sold as such, or dried or crystallised to produce dry sweeteners.

14.2.5 Modified (physical/chemical) starches

The properties of native starch can be changed to produce modified starch. Modification can be carried out with chemicals, enzymes or physically. The chemicals added can either be dry or wet, so final drying may be necessary. In the dry chemical modification process, dewatered and dried native starch is used. The products are chemically modified starches. In the wet process, the starch slurry, or the re-slurried native starch, is fed directly into the reactor with chemicals and the reaction takes place in a liquid state. The resulting slurry can be washed and/or dewatered prior to drying. The products are physico-chemically treated or modified starches.

14.2.6 Waste water treatment

Primary treatment for starch processing waste water includes the following techniques:

- flow and load equalisation (see Section 2.3.6.1.1);
- sedimentation (see Section 2.3.6.5.2);
- DAF (see Section 2.3.6.5.4).

If further treatment is needed, secondary treatment techniques are applied. Anaerobic processes (see Section 2.3.6.2.2) are used when the load of organic matter is high and when the TSS load is low, although reportedly long anaerobic treatments are sometimes used to treat waste water with high TSS levels. A methanisation reaction occurs and produces biogas which contains 50–70 vol-% methane and which is generally recovered in a boiler. The advantage of this treatment is that it removes a proportion of the COD load without producing sludge and that it saves energy. Nevertheless, such a reaction is difficult to optimise and its COD load removal efficiency can be between 50–80 %. The choice of having an anaerobic treatment depends also on the loading ratios, e.g. COD:N, BOD:N and N:P. The COD:N ratio should be high enough to allow bacteria to grow both in anaerobic and aerobic reactors. However, as COD and BOD removal rates are low, further treatment is needed.

The next step is generally an aerobic treatment (see Section 2.3.6.2.1). Oxygen is supplied by either surface aerators or blowing air in at the bottom of the tank. When the waste water has a COD higher than 10 000 mg/l, it is best not to subject it to aerobic treatment alone. However, aerobic techniques are suitable for less polluted waste water, e.g. condensed vapours from concentration systems or washing and flume water from potato starch production. In particular, when treating condensed vapours, it is important to ensure a balanced nutrient ratio (N:P). In addition, waste water from starch modification can be expected to have extremely unequal, carbohydrate-based organic loads with possible problems due to rising and bulking sludge [35, Germany 2002].

Finally, tertiary treatment includes biological nitrification and denitrification (see Section 2.3.6.3.1). It is reported that tertiary treatment is not always required.

The reported composition of waste water after treatment is given in Table 14.1.

Table 14.1: Characteristics of starch sector waste water after treatment

Parameter	Concentration (mg/l)	
	Minimum	Maximum
BOD	5	20
COD	50	300
Suspended solids	10	60
Total nitrogen	2	50
Total phosphorus	1	5
<i>Source: [63, CIAA-AAC-UFE 2002]</i>		

It is reported that waste water from starch installations is sometimes only subject to preliminary waste water treatment, such as sedimentation (see Section 2.3.6.5.2), and then sent off site for landspreading.

14.3 Current consumption and emission levels

Starch is manufactured from basically three major raw materials in Europe: maize, wheat and potatoes. The specific average consumption levels are as follows: 1.85 tonnes of maize, 2.35 tonnes of wheat or 6.6 tonnes of potatoes are used to produce 1 tonne of starch [63, CIAA-AAC-UFE 2002], [84, Austria 2002].

14.3.1 Energy consumption

The energy consumption depends on the starch and starch-derived products produced on site, i.e. on the techniques and processes involved in the starch production and co-products management. However, the main use of energy in starch production is thermal energy for the evaporation and drying processes. The energy used to produce starch slurry is low in comparison to the final production of dry products. More energy is consumed at sites where evaporation and/or drying processes are used for co-products such as fibre, solubles and proteins than at sites where solubles are landspread and fibre is sold as wet cattle feed.

Figure 14.8 shows data for specific energy consumption (MWh/tonne of raw materials) in various starch production installations. A distinction is also made between installations according to the different raw materials (the amount of raw materials refers to 100 % gross tonnage) they process. Lower specific energy consumption values have been reported in the case of potato processing.

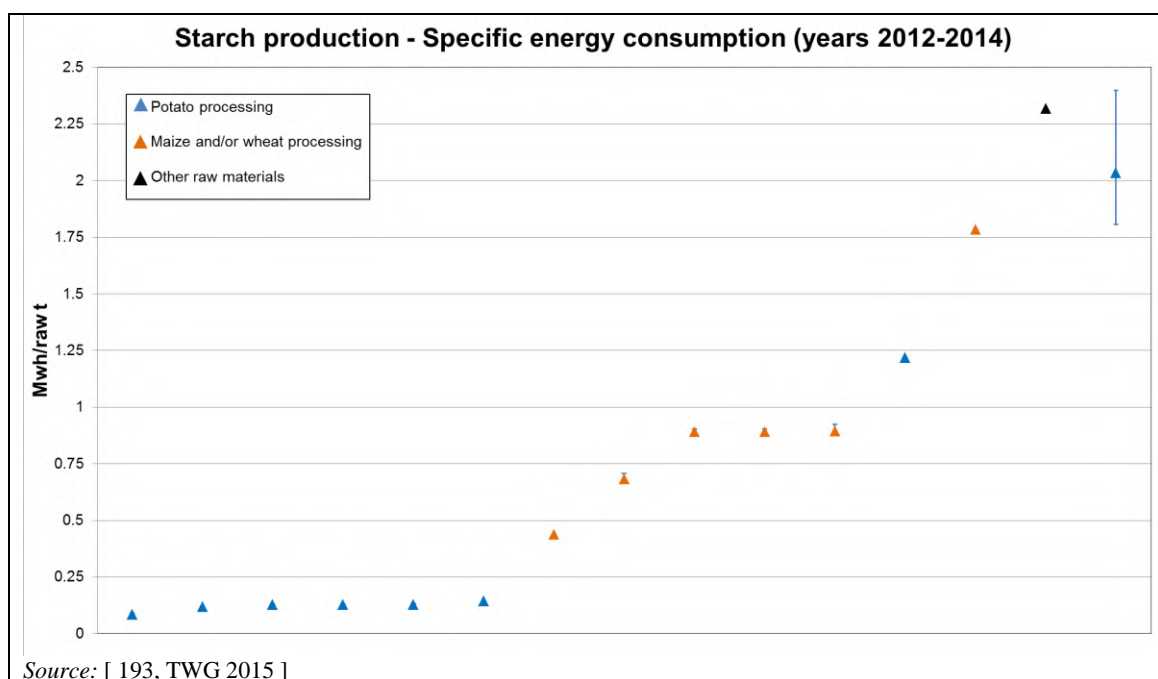

Figure 14.8: Specific energy consumption (MWh/tonne of raw materials) in starch production

The production of polyols requires additional transformation steps beyond liquid glucose (e.g. hydrogenation of the glucose in a pressurised heated reactor, drying of liquid polyols), which are associated with increased energy consumption.

14.3.2 Water consumption

Water consumption also depends on the starch and starch-derived products produced on a particular site. The water consumption also differs according to the raw material used. Due to the higher water content of potatoes, the potato starch process requires less water than the cereal starch process. The starch industry has realised substantial savings in fresh water consumption through process-integrated measures, internal recycling of process water and optimisation of the cooling water system. Nevertheless, due to product applications, e.g. food and pharmaceutical, and to quality requirements, process water recycling is not always possible.

Figure 14.9 shows data for specific water consumption (m^3/tonne of raw materials) in various starch production installations.

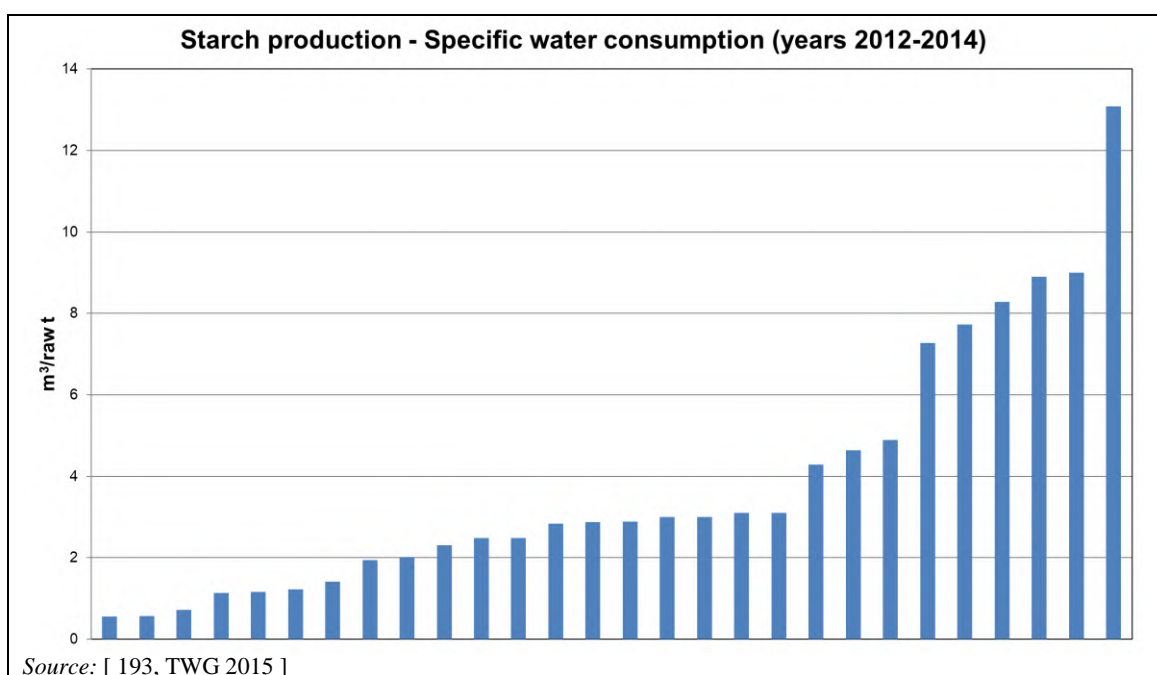

Figure 14.9: Specific water consumption (m^3/tonne of raw materials) in starch production

The production of polyols requires additional transformation steps beyond liquid glucose (e.g. purification of polyols using ion exchangers), which are associated with increased water consumption.

14.3.3 Solid output

There are many factors that affect the amount of sludge after waste water treatment. It is reported that the type and the efficiency of the manufacturing process used are the most important. Also, practically no sludge is generated if anaerobic waste water treatment is carried out before discharging to the MWWTP. Some by-products, e.g. gluten produced in starch manufacturing, can be used in other food or animal feed processes, or sent for landspreading.

14.3.4 Emissions to water

Waste water from the starch sector contains high levels of organic matter which is readily biodegradable. COD and BOD levels rise due to the hydrolysis and fermentation of, for example, reduced sugars, volatile acids and aldehydes. The TSS content is not high.

Nitrogen is also present in the waste water. It is produced due to the degradation of proteins, e.g. urea and ammonia. The nitrogen content appears to be higher for waste water from potato processing than from grain processing. Metals, e.g. Zn, Ni and Cr, can be found in very limited quantities. When found, they have arisen from the corrosion of metallic vessels and pipes, and from the raw material, e.g. corn, rice and potatoes.

Figure 14.10 shows reported data on specific waste water discharges (m^3/tonne of raw materials) from starch production installations and all types of discharges. A distinction is also made between the installations according to the different raw materials (the amount of raw materials refers to 100 % gross tonnage) they process. More information on emissions to water can be found in Section 2.2.3.

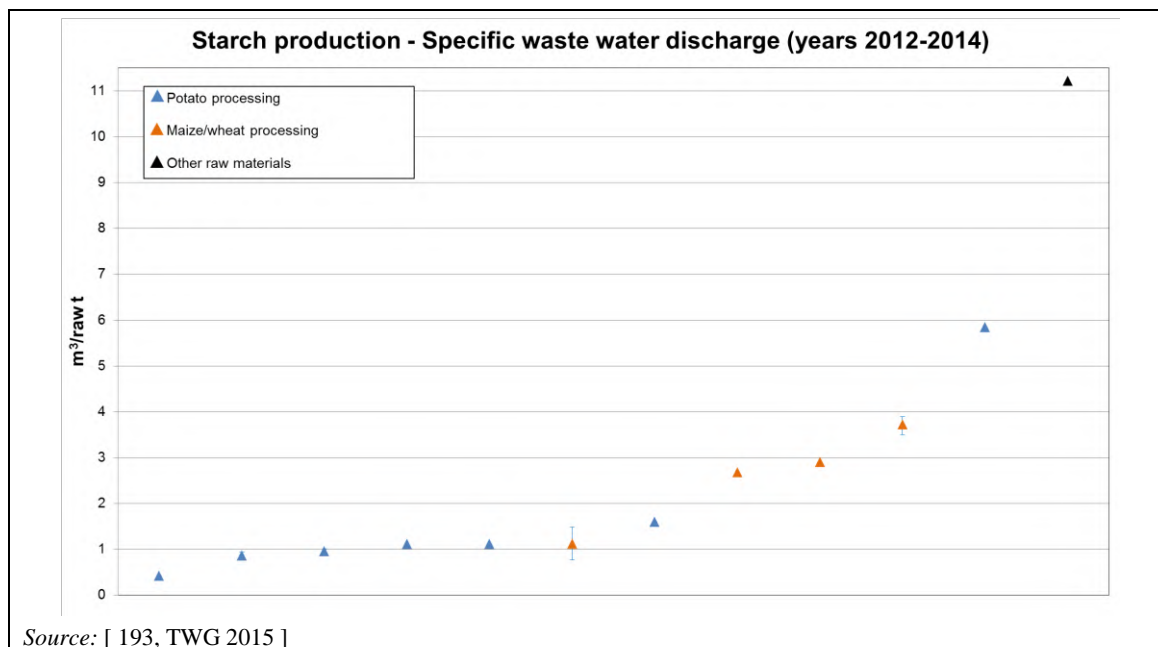

Figure 14.10: Specific waste water discharge (m^3/tonne of raw materials) in starch production for all types of discharges

14.3.5 Emissions to air

14.3.5.1 Dust emissions from dryers

Bag filters and cyclones (depending on the nature of the dust to be treated) are mainly used as final abatement techniques for dust emissions from dryers. Wet scrubbers, generally in combination with cyclones (as a first step), are also applied in a few cases. According to submitted data, most starch dryers operate near atmospheric O_2 levels. A general overview of the data received for dust emissions to air from dryers is shown in Figure 14.11 (lower values) and Figure 14.12 (higher values). The applied end-of-pipe abatement techniques are also indicated.

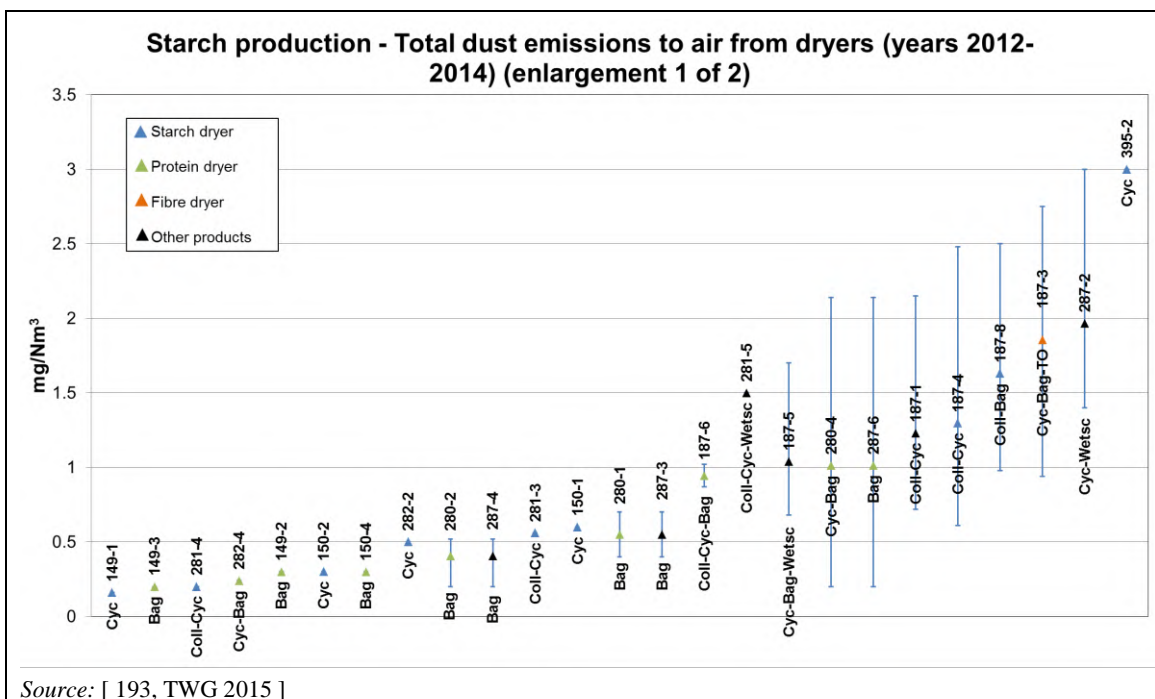

Figure 14.11: Total dust emissions to air from dryers (1 of 2)

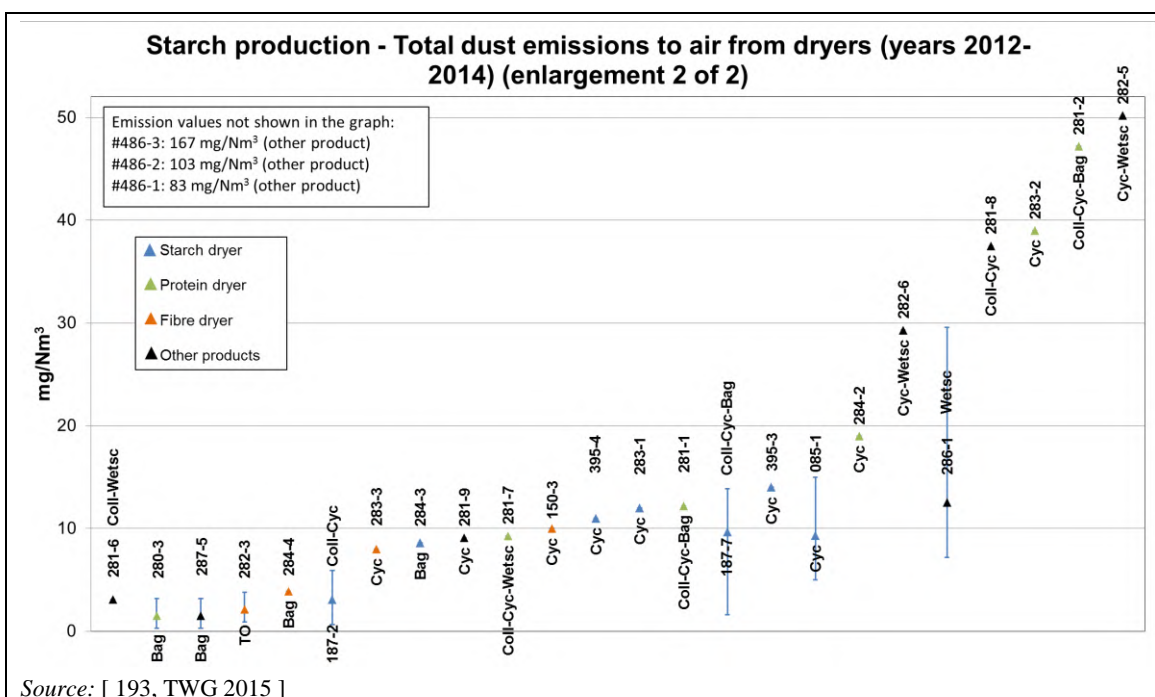

Figure 14.12: Total dust emissions to air from dryers (2 of 2)

The meaning of the symbols and abbreviations used in Figure 14.11 and Figure 14.12 are indicated in Table 3.3 and Table 3.4.

14.3.5.2 Dust emissions from preparation of raw materials

Data from monitoring of dust emissions from the preparation of raw materials are shown in Table 14.2.

Table 14.2: Total dust emissions to air from preparation of raw materials (dry basis)

Installation ID-point of release	Dust (mg/Nm ³)	O ₂ content (%)	Frequency of monitoring	Monitoring standard	Sampling duration (h)	Abatement technique
282-1	0.10	20.90	NI	EN 13284-1	NI	Bag filters
284-1	2.80	20.90	Yearly	EN 13284-1	1.00	Bag filters

NB: NI = no information provided.
 Source: [193, TWG 2015]

14.4 Techniques to consider in the determination of BAT

14.4.1 Techniques to increase energy efficiency

14.4.1.1 Heat recovery for preheating the potato juice

See also Section 2.3.2.1.1.

Description

Potato juice is heated up using the heat from the potato water during the protein separation stage.

Technical description

Preheating of potato juice to about 100 °C is performed by reusing hot potato juice, from which the protein already has been extracted. Spiral or plate heat exchangers are commonly used.

This spiral exchanger is a fully welded construction that differentiates itself by having a long channel duct, whereby the flow precipitated protein maintains the same pace during the entire preheating session. At the same time, the potato juice is heated up slowly, which ensures a high uniform protein quality and also reduces potential precipitation in the exchanger. The heating medium on the opposite side of the channel allows heat to be recovered from the potato water outlet. The preheated potato juice is then channelled via pipelines to a further heating step.

Achieved environmental benefits

Reduction of energy consumption.

Environmental performance and operational data

Reduction of energy consumption for potato juice heating of around 50 %.

Cross-media effects

No information provided.

Technical considerations relevant to applicability

Applicable to potato starch plants.

Economics

An investment cost of EUR 1 300 000 (capacity about 100 m³/h in terms of potato juice) and annual savings of EUR 200 000 (reduction of natural gas consumption) have been reported (installations #149, #150, #151 and #152).

Driving force for implementation

Reduced energy costs.

Example plants

Installations #149, #150, #151 and #152.

Reference literature

[108, NEWPOTATOPRO LIFE project 2007], [193, TWG 2015]

14.4.2 Techniques to reduce water consumption

14.4.2.1 Countercurrent water use/reuse in starch washing

See also Section 2.3.3.1.1.

Description

Water from the treatment of the end product can be reused to wash raw starch slurry.

Technical description

Countercurrent flow is commonly applied by using drinking water only at the end of the production line for treating the end product, i.e. usually the cleanest part of the process. The water from this step is relatively clean and can be reused in another process step, for which the water is sufficiently clean, usually earlier in the process, i.e. the water flows countercurrently to the product, so that the final product only comes into contact with fresh drinking water. The technique may be operated either continuously or in batches.

For instance, it is common practice to wash raw starch slurry, using a countercurrent flow, before it is dewatered and dried to produce refined starch. The starch is washed with drinking water, using a countercurrent flow, in a series of four to six centrifuges. At one end, raw starch is the input and process water is the output and, at the other end, refined starch is the output and fresh drinking water is the input.

Achieved environmental benefits

Reduced water consumption and consequently reduced waste water generation.

Environmental performance and operational data

No information provided.

Cross-media effects

No information provided.

Technical considerations relevant to applicability

Applicable when several washing stages are required, which need progressively cleaner water.

Economics

No information provided.

Driving force for implementation

Reduction of costs associated to waste water treatment.

Example plants

Numerous installations producing starch from maize, wheat or potatoes.

Reference literature

[94, Germany 2003], [116, CIAA-AAC-UFE 2003]

14.4.2.2 Reuse of process water in potato starch manufacturing

Description

Reuse of process water in potato starch manufacturing.

Technical description

Where starch and starch derivatives are manufactured from potatoes, large volumes of potato starch manufacturing waste water may be produced. A system for reusing the potato water and process water is summarised in Figure 14.13.

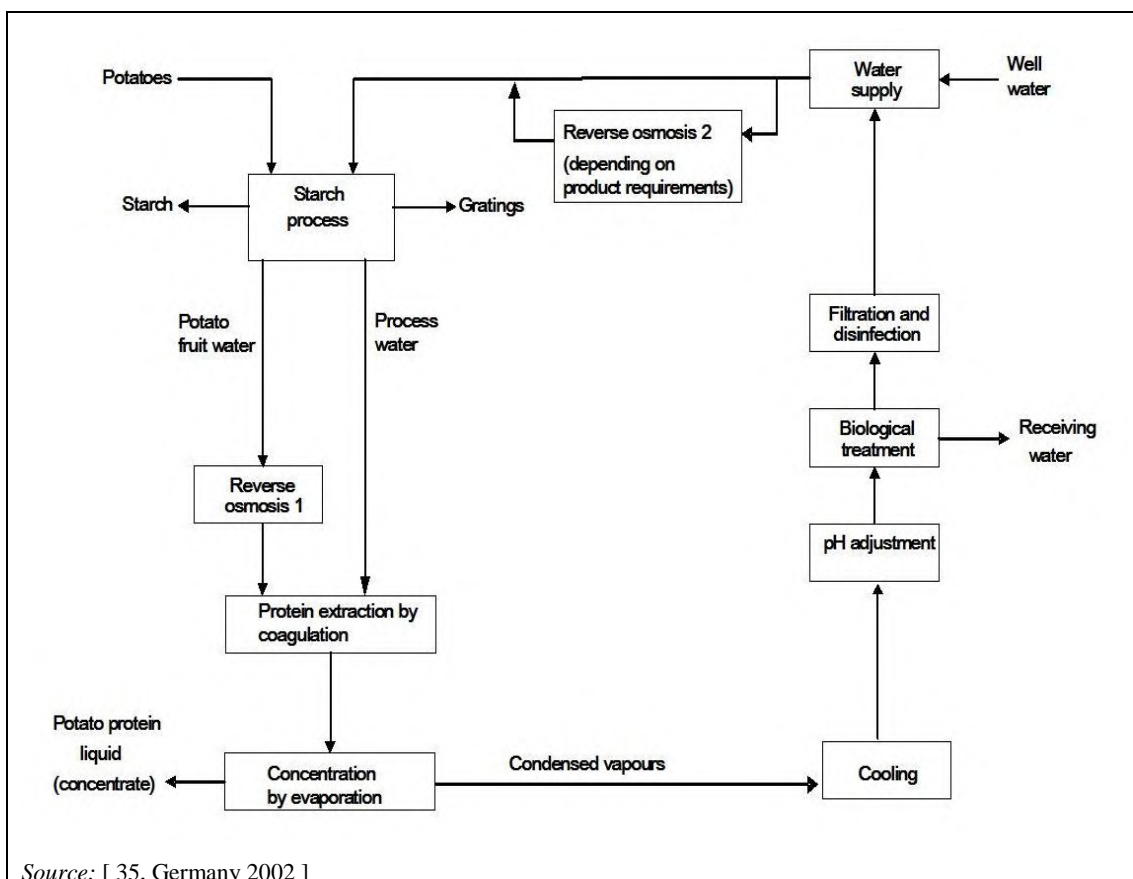

Figure 14.13: Water circuit in a potato starch installation

First, the potato water is treated by RO. The treated potato water is then sent, together with the process water, for protein extraction, by coagulation. The next process step is concentration by evaporation of the deproteinised potato water and the process water. The condensed vapours obtained from this evaporation step are cooled and the pH is adjusted before being fed to the biological WWTP. Some of the purified water undergoes further treatment where it is first filtered through a sand filter and then disinfected. The water recovered is mixed with fresh water and returned to the production process. Optionally, depending on product requirements, a second RO step can be performed.

Achieved environmental benefits

Reduction in both fresh water consumption and waste water volume.

Environmental performance and operational data

The design characteristics of the evaporation step of an example installation are shown in Table 14.3 and the biological waste water treatment characteristics are shown in Table 14.4.

Table 14.3: Concentration of potato starch process water by evaporation – design data

Inlet	Total inlet flow	213 m ³ /h (on the basis of continuous feed)
	Process water from starch manufacturing	Flow volume 1 = 110–145 m ³ /h Dry matter content = 1.8–2 % Temperature Inlet protein unit = 38–40 °C After protein unit = 86 °C
	Coagulated potato water from protein unit	Flow volume 2 = 100–115 m ³ /h Dry matter content = 5.5–6 % Temperature leaving protein unit = 86 °C ± 1 %
Output	Product	Potato protein liquid with at least 55 % dry matter
	Condensate	As cool and as pure as possible
Performance	Steam removal capacity	At least 230 t/h
	Pre-evaporator	At least 196 t/h
	Final evaporator	At least 34 t/h
	Concentration temperature	Maximum 87 °C
	Reserve capacity	At least 15 % in terms of steam removal capacity
	Operation cycle	Operating time at least 120 h Cleaning time maximum 9 h
<i>Source: [35, Germany 2002]</i>		

Table 14.4: Biological waste water treatment characteristics in a potato starch installation

Waste water type	Condensed vapours from concentration unit	
Process	Activated sludge process Sand filter Disinfection	
Basic design data	Waste water volume	200 m ³ /h
	COD concentration	1 500 ± 300 mg/l
	COD load	7 200 ± 1440 kg/d
Waste water characteristics	COD	< 25 mg/l
	BOD ₅	< 10 mg/l
Characteristics of the activated sludge treatment 2 basins, each of 1 375 m ³ (= 2 750 m ³) aerobic volume including preceding selector	Hydraulic residence time	= 13.8 h
	Hydraulic load	= 1.75 m ³ /m ³ per day
	COD volume load	= 2.6 kg/m ³ per day
	Sludge concentration	= 5 000 g/m ³
	COD sludge load	= 0.52 kg COD/kg dry matter per day
	Return sludge volume	= maximum 200 m ³ /h
Final sedimentation Secondary sedimentation 1 circular transverse-flow sedimentation basin	Diameter	= 23 m
	Water depth	= 5 m
	Volume	= 2 076 m ³
	Surface area	= 415 m ²
	Residence time	= 10.38 h
	Surface load	= 0.48 m/h
Sand filtration 3 units	In-feed flow rate	= (maximum) 3 x 70 m ³ /h
	Washing water flow rate	= (maximum) 3 x 70 m ³ /h
	Hydraulic load	= 8 m/h
Disinfection	UV disinfection and ClO ₂ metering	
<i>Source: [35, Germany 2002]</i>		

Cross-media effects

Increased energy consumption and surplus sludge production.

Technical considerations relevant to applicability

Condensed vapours in the potato starch industry are highly degradable, making the treatment by RO and evaporation stages dependent on the special properties of potato water and process water.

Economics

It is reported that the cooling of treated condensed vapours may not necessarily be economical.

Driving force for implementation

The reduction in fresh water consumption reduces costs.

Example plants

At least one installation manufacturing starch from potatoes in Germany.

Reference literature

[35, Germany 2002]

14.4.3 Techniques to reduce waste**14.4.3.1 Separation of residues**

This technique is described in Section 2.3.5.3.

There are many other opportunities to apply this technique within the sector. For example, some water-diluted materials can be recovered, if the water is collected, e.g. potato starch can be recovered from starch water.

Technical considerations relevant to applicability

Applicable to potato starch installations.

Reference literature

[8, Environment Agency of England and Wales 2000], [19, German Dairy Association 2001], [21, Nordic Council of Ministers 2001], [42, Greek Ministry for the Environment 1997], [71, AWARENET 2002]

14.4.4 Techniques to reduce emissions to air**14.4.4.1 Techniques to reduce dust emissions from dryers****14.4.4.1.1 Bag filter**

The technique is generally described in Section 2.3.7.2.2.

Environmental performance and operational data

Table 14.5 shows installation-specific performance data related to the application of bag filters as the dust abatement technique. The reported data refer to dry gas, unless otherwise indicated in the "Additional information" column.

Table 14.5: Total dust emissions to air from a dryer after treatment in a bag filter

Installation ID-point of release	Dust (mg/Nm ³)	O ₂ content (%)	Monitoring standard	Frequency of monitoring	Additional information
149-2	0.30	19.90	EN 13284-1	Yearly	Potato Native starch Flash dryer (starch drying) Natural gas
150-4	0.30	NI	EN 13284-1	Yearly	Potato Native starch Rotary dryer (protein drying) Natural gas
280-1	0.40	NI	EN 13284-1	Yearly	Wheat Native, hydrolysed starch Flash dryer (protein drying) Steam
280-2	0.52	NI	EN 13284-1	Yearly	Wheat Native, hydrolysed starch Flash dryer (protein drying) Steam
486-4	< 1	NI	EN 13284-1	Four times a year	Wheat Flash dryer (protein drying) Natural gas
287-5	1.04	NI	EN 13284-1	Yearly	Wheat Native, hydrolysed starch Flash dryer (protein) Steam
187-8	2.50	21.00	EN 13284-1	Yearly	Maize Native, modified, hydrolysed starch Flash dryer (starch drying) Hot air from exchanger Moisture content in exhaust air of dryer, around 1.6 %
187-5	2.75	15.00	EN 13284-1	Yearly	Maize Native, modified, hydrolysed starch Rotary dryer (fibre drying) Natural gas Moisture content in exhaust air of dryer, around 8.9 % Cyclone step before
284-4	3.90	20.90	EN 13284-1	Yearly	Pea Native starch, modified starch Flash dryer (fibre drying) Hot air from exchanger

NB: NI = no information provided.

Source: [193, TWG 2015]

Reference literature

[193, TWG 2015]

14.4.4.1.2 Cyclone

The technique is generally described in Section 2.3.7.2.3.

Environmental performance and operational data

Table 14.6 shows installation-specific performance data related to the application of cyclones as the dust abatement technique. The reported data refer to dry gas, unless otherwise indicated in the "Additional information" column.

Table 14.6: Total dust emissions to air from a dryer after treatment in a cyclone

Installation ID-point of release	Dust (mg/Nm ³)	O ₂ content (%)	Monitoring standard	Frequency of monitoring	Additional information
149-1	0.16	NI	EN 13284-1	Yearly	Potato Native starch Flash dryer (starch drying) Natural gas
281-4	0.20	20.90	EN 13284-1	Once every four years	Wheat, maize Native, modified, hydrolysed starch Flash dryer (starch drying) Hot air from exchanger Sticky dust, 13 % moisture
150-4	0.30	NI	EN 13284-1	Yearly	Potato Native starch Flash dryer (protein drying) Natural gas
150-1	0.60	NI	EN 13284-1	Yearly	Potato Native starch Flash dryer (starch drying) Natural gas
187-4	2.48	21.00	EN 13284-1	Yearly	Maize Native, modified, hydrolysed starch Flash dryer (starch drying) Hot air from exchanger Moisture content in exhaust air of dryer, around 1.6 %
395-2	3.00	21.00	EN 13284-1	Once every three years	Potato Native starch Flash dryer (starch drying) Steam
283-3	8.00	NI	NI	NI	Potato Native, modified starch Flash dryer (fibre drying) Natural gas Sticky dust

Installation ID-point of release	Dust (mg/Nm ³)	O ₂ content (%)	Monitoring standard	Frequency of monitoring	Additional information
150-3	10.00	NI	EN 13284-1	Yearly	Potato Native starch Rotary dryer (fibre drying) Natural gas
283-1	12.00	20.90	NA	NA	Potato Native, modified starch Flash dryer (starch drying) Hot air from exchanger Sticky dust, 21 % moisture
085-1	15.00	NI	EN ISO 16911-1	Yearly	Potato Native, modified starch Flash dryer (starch drying) Hot air from exchanger Dust particles with a residual humidity of 20 %
284-2	19.00	20.90	EN 13284-1	Yearly	Pea Native, modified starch Spray dryer (protein drying) Hot air from exchanger Sticky dust (7 % moisture)
281-8	37.50	18.50	EN 13284-1	Biennial	Wheat, maize Native, modified starch, hydrolysed starch products Rotary drier (fibre drying) Natural gas Sticky dust
283-2	39.00	20.90	NA	NA	Potato Native, modified starch Flash/ring dryer (protein drying) Natural gas Sticky dust

NB: NI = no information provided.
Source: [193, TWG 2015]

Reference literature

[193, TWG 2015]

14.4.4.1.3 Wet scrubber

The technique is generally described in Section 2.3.7.3.1.

Environmental performance and operational data

Table 14.7 shows installation-specific performance data related to the application of wet scrubbers as the dust abatement technique. The reported data refer to dry gas, unless otherwise indicated in the "Additional information" column.

Table 14.7: Total dust emissions to air from a dryer after treatment in a wet scrubber

Installation ID-point of release	Dust (mg/Nm ³)	O ₂ content (%)	Monitoring standard	Frequency of monitoring	Additional information
187-5	0.74	21.00	EN 13284-1	Yearly	Maize Native, modified, hydrolysed starch Germ drying Cyclone and bag filter step before
287-2	1.40	6.43	EN 13284-1	Yearly	Wheat Native starch, hydrolysed starch products Rotary dryer (protein dryer operating at ethanol plant) Natural gas Cyclone step before
281-5	1.50	11.80	EN 13284-1	Biennial	Wheat, maize Native, modified, hydrolysed starch Rotary dryer (fibre drying) Natural gas Sticky dust Cyclone step before
281-7	9.28	20.90	EN 13284-1	Biennial	Wheat, maize Native, modified, hydrolysed starch Steam dryer (protein drying) Hot air from exchanger Sticky dust Cyclone step before
486-2	19.16	NI	EN 13284-1	Monthly	Wheat Spray dryer (hydrolysed products drying) Natural gas
282-6	29.30	20.90	EN 13284-1	Once every four years	Wheat, maize Native, modified, hydrolysed starch Spray dryer (hydrolysed products drying) Hot air from exchanger Sticky dust Cyclone step before

NB: NI = no information provided.
Source: [193, TWG 2015]

Reference literature

[193, TWG 2015]

14.4.4.2 Techniques to reduce dust emissions from preparation of raw materials

14.4.4.2.1 Bag filters

The technique is generally described in Section 2.3.7.2.2.

Environmental performance and operational data

Table 14.8 shows installation-specific performance data related to the application of bag filters as the dust abatement technique.

Table 14.8: Total dust emissions to air from raw material preparation after treatment in a bag filter (dry basis)

Installation ID-point of release	Dust (mg/Nm ³)	O ₂ content (%)	Monitoring standard	Frequency of monitoring	Additional information
282-1	0.10	20.90	EN 13284-1	NA	Unloading of raw materials from train to silo
284-1	2.80	20.90	EN 13284-1	Yearly	Pea grinding machine (milling)

NB: NI = no information provided.
 Source: [193, TWG 2015]

Reference literature

[193, TWG 2015]

15 SUGAR MANUFACTURING

15.1 General information about the sector

Beet and sugar production in the EU is based on a market organisation known as the common market organisation (CMO) of the sugar sector or Sugar CMO. In 2006, this CMO was thoroughly reformed, leading to a large reduction in the sugar production quota of around 6 million tonnes (-30 %). This left a remaining sugar production quota of around 13.3 million tonnes. Key to the reform was a 36 % cut in the reference sugar price (from EUR 631.9/tonne in the 2006/2007 campaign to EUR 404.4/tonne in the 2009/2010 campaign) and the removal of the intervention mechanism that guaranteed a minimum sugar price.

In the 2014/15 campaign, beet sugar production was distributed among 19 EU Member States, with 70 % of the production concentrated in four countries (see Figure 15.1).

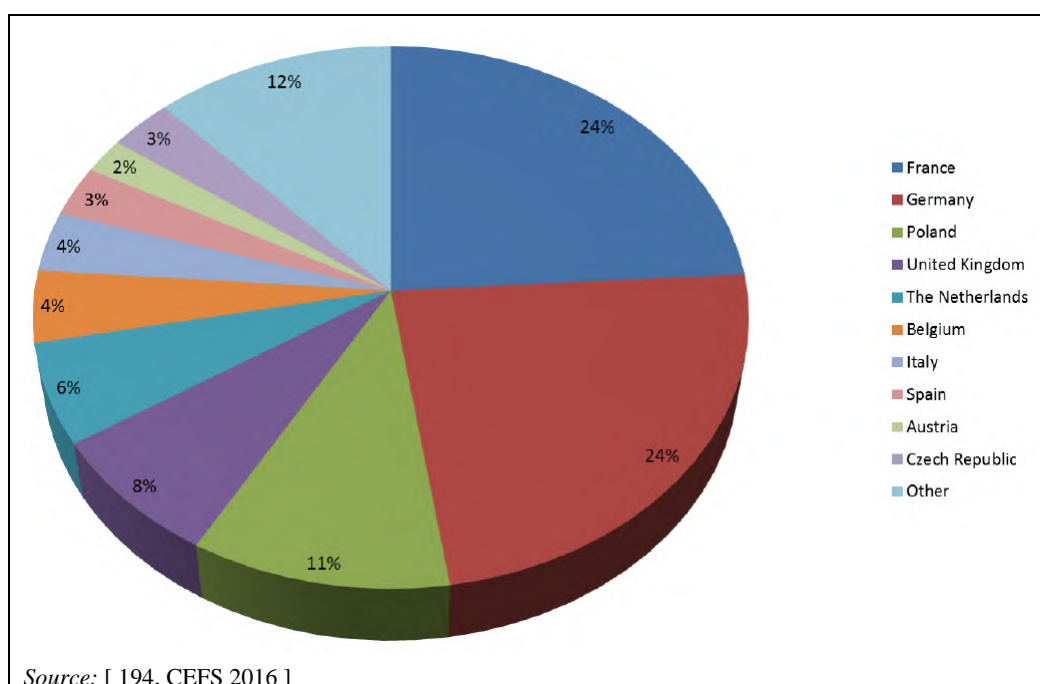

Figure 15.1: Distribution of sugar production in the EU-28 (2015)

In the years leading up to and following the adoption of the CMO reform, the number of EU sugar factories has fallen as the industry has undergone major restructuring driven by the need to improve efficiency. In the 2000-2008 period, 151 factories were closed, resulting in an overall reduction of 60 % of European processing capacity. Since 2010, the number of factories has remained stable at 109 across the EU-28. Taking into account both direct and indirect employment, the beet sugar industry in the EU supports about 180 000 jobs and contributes to the revenue of 140 000 farms [194, CEFS 2016].

Since the 2016/2017 campaign, there is no longer a sugar production quota or a reference price for EU beet sugar and the EU sugar market is becoming one of the most open markets in the world.

15.2 Applied processes and techniques

Sugar (sucrose) is produced from two principal sources, sugar beet and sugar cane. Sugar beet tends to be grown in Europe and the temperate zones of the northern hemisphere and sugar cane in hotter climates with Brazil, India and China being the largest producers, so cane sugar is not extracted in Europe [98, TWG 2017]. Sucrose is also available in a liquid form as an aqueous solution, in some cases all or partially inverted. Sugar crystals may be ground to make powdered or confectioner's sugars. Anti-caking agents such as maize starch are added to keep these sugars free-flowing.

From common household white sugar to high-tech products, the companies of the European sugar industry are active in the development of a wide range of products, all of which originate from sugar beet. These include food ingredients, animal feed, green chemistry products (replacing petroleum-based materials) and biofuels such as bioethanol and biogas (see Figure 15.2).

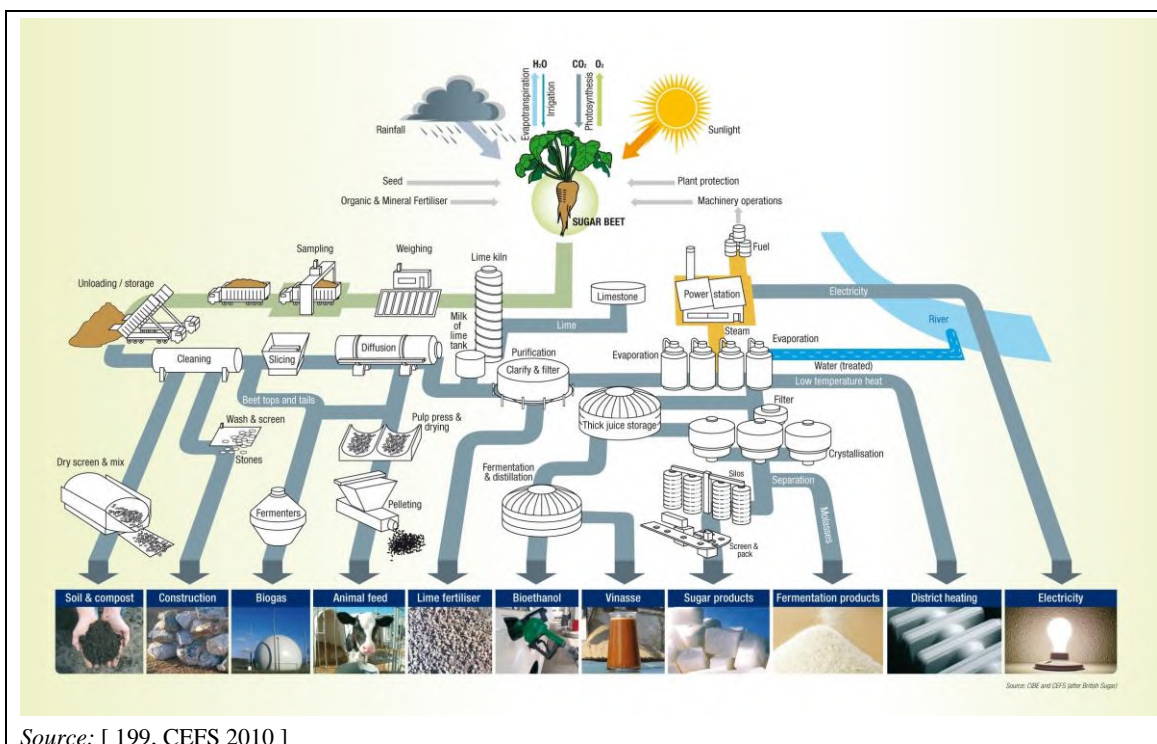

Figure 15.2: Product range in a sugar factory

15.2.1 Sugar beet extraction

In general, the extraction of sugar from sugar beet and sugar cane is similar. The beets are cut into thin slices called cossettes. They are passed into a water-based countercurrent extraction apparatus called a diffuser and emerge as impure sugar juice and beet pulp. The fresh water used in the extraction process is actually condensed water from the subsequent evaporation steps together with recirculated water from the pulp pressing. The temperature inside the diffuser is 68–72 °C.

Three types of diffusers are used:

- Horizontal diffusers are large revolving drums, separated into cells by a helix attached to the interior surface. As the drum and helix revolve, the juice, which stays at the bottom of the vessel, is transported countercurrently to the cossettes, i.e. the exhausted beet pulp leaves the diffuser at the same end where the fresh water enters.
- Vertical diffusers are composed of an extractor with two main and distinct parts, i.e. the countercurrent mixer and the extraction tower. The tower is a 14–20 m high cylinder. Inside the tower, a tubular shaft rotates slowly. Special helicoidal steel pieces, or flights, are fitted on the shaft and move the cossettes upwards. The juice and the cossettes move countercurrently.
- Slope diffusers consist essentially of a U-shaped sloping vessel in which two overlapping screws with opposite pitches rotate. Fresh cossettes fall from a conveyor belt into the lower end. The cossettes are transported upwards by the two screws to a paddle wheel, which lifts the exhausted cossettes out of the extractor. Fresh water is introduced at the upper end and the sugar juice leaves the extractor through a screen at the lower end.

The crystallisation process takes place in vacuum pans in which the juice is boiled under vacuum to minimise the temperatures involved. The growth of the sucrose crystal only involves sucrose and water. The non-sugars contained in the sugar juice are not incorporated into the crystal structure; instead, most of them remain in the liquid phase while some are released to the vapour phase. The sugar crystals are removed from the liquid phase by centrifugation.

Sugar to be stored in silos is dedusted and cooled to the storage temperature. This is carried out in a sugar cooler, which is a device in which warm and dried sugar is intensively aerated by cold filtered external air to cool the sugar to the storage temperature, approximately 20–30 °C. The most common systems in use are typically drum or fluidised bed coolers with chilling systems that have a countercurrent or cross-current phase flow.

15.2.2 Drying of sugar beet pulp

Dried pulp can be obtained by drying the pulp to a solids content of 86–92 %. About 5.6 kg dried pulp with a solids content of 90 % can be produced from 100 kg of sugar beet. If 1–3 % of molasses, based on the weight of the pulp, is added before drying, molassed dried pulp with a varying sugar content, e.g. 9–30 %, is obtained. Apart from the sugar content, the concentrations of HCl-insoluble substances, calcium and ash are controlled in each country according to feed regulations.

Pulp drying is generally carried out by convection drying, e.g. drying with air, hot gas or steam. When drying with air or hot gas, the drying gas is heated and then brought into contact with the pulp. Warm, dry air can take up water vapour until it is saturated. Heat and substance transfer take place simultaneously in the drying process. In the first drying period, the drying rate remains practically constant. During this period, unbound liquid is vaporised from the surface of the solid and carried away by the drying agent. When the moisture content is reduced below a critical value, the surface of the solid dries out, and further evaporation takes place in the interior of the porous solid. This is called the second drying period. The residual moisture in the solid is bound to it by sorption. The drying rate decreases rapidly with a decreasing moisture

content and tends to zero as the hygroscopic equilibrium moisture content is approached. The regime between the maximum hygroscopic moisture content and the equilibrium value is designated as the third drying period. The lower the residual moisture content of the pulp is supposed to be, the lower the necessary residual moisture level in the drying gas.

When drying with steam, the requirements for the drying gas are similar. High dry matter levels in the material being dried require high residual superheating of the steam, corresponding to the low relative humidity in the air.

An alternative is solar drying, which allows for savings in terms of electricity and gas consumption (see Section 15.4.1.3).

Options for beet pulp drying at sugar processing installations are described in Section 15.4.1. The decision about whether to dry sugar beet pulp depends on factors such as whether there is a nearby outlet for the wet pulp, e.g. for animal feed, or the climate conditions in the case of solar drying. The storage of wet pulp can cause odour problems and the transport of wet pulp is expensive. In several European countries, e.g. France, beet pulp may be dried in installations which usually belong to farmers and are not directly connected to the sugar production process.

15.2.3 Sugar cane

Raw cane sugar is usually separated, purified and crystallised in the country of origin. The cane sugar, which is in a crudely refined state, undergoes final processing when transferred to the country of use.

15.2.4 Sugar refining

Raw sugar is typically a minimum of 96 % sucrose. The impure crystals, with adhering molasses, are blended in a saturated sugar solution to soften the surface molasses film which can then be removed by centrifugation. The partly processed sugar is dissolved in reclaimed liquors, i.e. light water from the refining process.

Carbonatation then follows. Carbonatation is the introduction of the milk of lime, calcium hydroxide and carbon dioxide gas (CO₂) into a liquid to form calcium carbonate and to precipitate and remove impurities. The effect of lime and CO₂ is the precipitation of insoluble calcium salts, the flocculation of colloidal components, the chemical degradation of other molecules such as invert sugar and amides, and the absorption of non-sugars on precipitated calcium carbonate. Lime and CO₂ are normally produced in lime kilns by the thermal dissociation of limestone.

The product after filtration contains the calcium carbonate and the non-sugars and is used in agriculture as a liming material to improve the structure of arable soil and to regulate soil acidity. Sugar factory lime may also be used for site recovery, e.g. filling quarry ditches, and for producing bricks or cement.

The sugar syrup is filtered and decolourised using ion exchange resins and activated carbon to produce a fine liquor, which may be sold as a finished product or passed on for crystallisation.

Decolourisation can be carried out by the addition of an active powder, e.g. powdered activated carbon, to the product in aqueous solution, which is then mixed under controlled conditions. Afterwards, the powder is removed by filtration, using static filters or rotary vacuum filters, while the decoloured product is processed further. This process is often carried out in multiple stages with the active material being reused until exhausted, often using a countercurrent system. The process can also be carried out by passing the product in aqueous solution through a column of active material, e.g. using granular activated carbon or ion exchange resin beads. Here, only minimal filtration is required after the process as the active material is held in place.

Active material is withdrawn from the column at regular intervals and replaced by new or reactivated material.

The decolourisation process produces a filter residue consisting of the active material, any filter aid used and some residual product. This solid output is sometimes sent to landfill or for landspreading/composting depending on its nature. Depending on the type of process/product, this solid output can also be used as animal feed.

General information about lime manufacturing can be found in the CLM BREF [166, COM 2013].

The fine liquor is concentrated by evaporation to produce a syrup of around 60–70 % solids, known as thick juice. The juice is filtered and transferred to vacuum pans. When the liquor is slightly supersaturated, the pan is seeded with fine icing sugar to initiate crystallisation. The mixture is centrifugally separated to extract crystalline sugar, which is dried, conditioned for packaging or bulk loaded. Each pan boiling yields around 50 % of the available sugar.

The liquor separated during centrifugation, also called jet, is reboiled for further extraction. Three boilings yield white sugar. A fourth boiling yields off-white industrial sugar. Jet four, together with liquor from blending, goes to a recovery house for three further boilings to produce brown sugars which go back to the start of the refining process and are treated as raw sugar. Various intermediary products from jets one to four and the corresponding syrups from recovery and boiling are sold as the starting materials for syrups such as molasses and treacle. Molasses are sometimes used in animal feed, alcoholic fermentation and a number of non-food products.

15.3 Current consumption and emission levels

Most of the information in this section comes from the ‘Guide to Establishing BAT in the Sugar Industry; Comité Européen des Fabricants de Sucre (June 2001)’ [31, CEFS 2001], unless otherwise stated.

15.3.1 Sugar beet

15.3.1.1 Energy consumption

Significant thermal energy is consumed for the evaporation and beet pulp drying. Electrical energy is needed for the pumps and for driving the centrifuges.

Figure 15.3 shows data on specific energy consumption (MWh/tonne of sugar beet) in the various sugar beet installations.

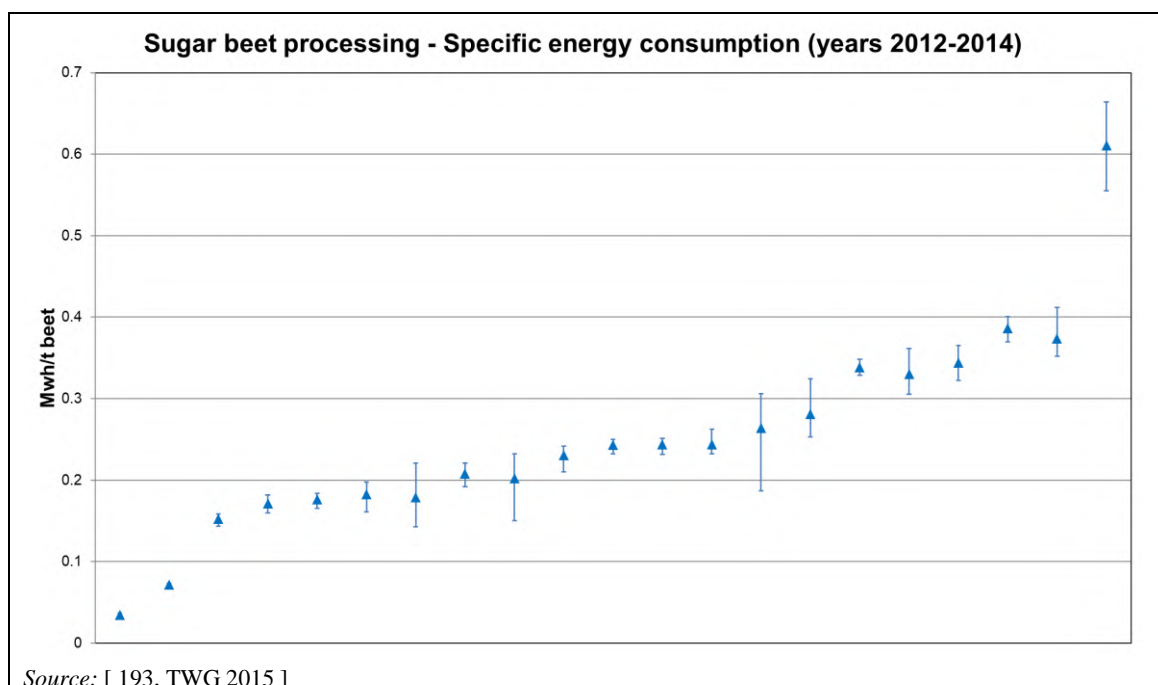

Figure 15.3: Specific energy consumption (MWh/tonne of sugar beet) from sugar beet processing

15.3.1.2 Water consumption

The water requirement for fluming is about 500–800 % of the amount of beet. For washing, 150–200 % is needed, and for a single stone catcher 70–100 % water is needed based on the amount of beet. The mechanically clarified water is reused for fluming and washing, thus only 25–30 % beet-based industrial water needs to be added during the last rinsing of the beets after washing.

Smaller losses are caused by evaporation of the cooling water and by discharging by-products and wastes containing water. However, the root body consists of about 75–78 % water; therefore, the beets carry sufficient water into the processing, which accumulates as condensate. Thus, an installation producing sugar is a net water producer, because the water contained initially in the beet becomes available as surplus cooling water [71, AWARENET 2002].

Figure 15.4 shows data on specific water consumption (m^3/tonne of sugar beet) in various sugar beet installations.

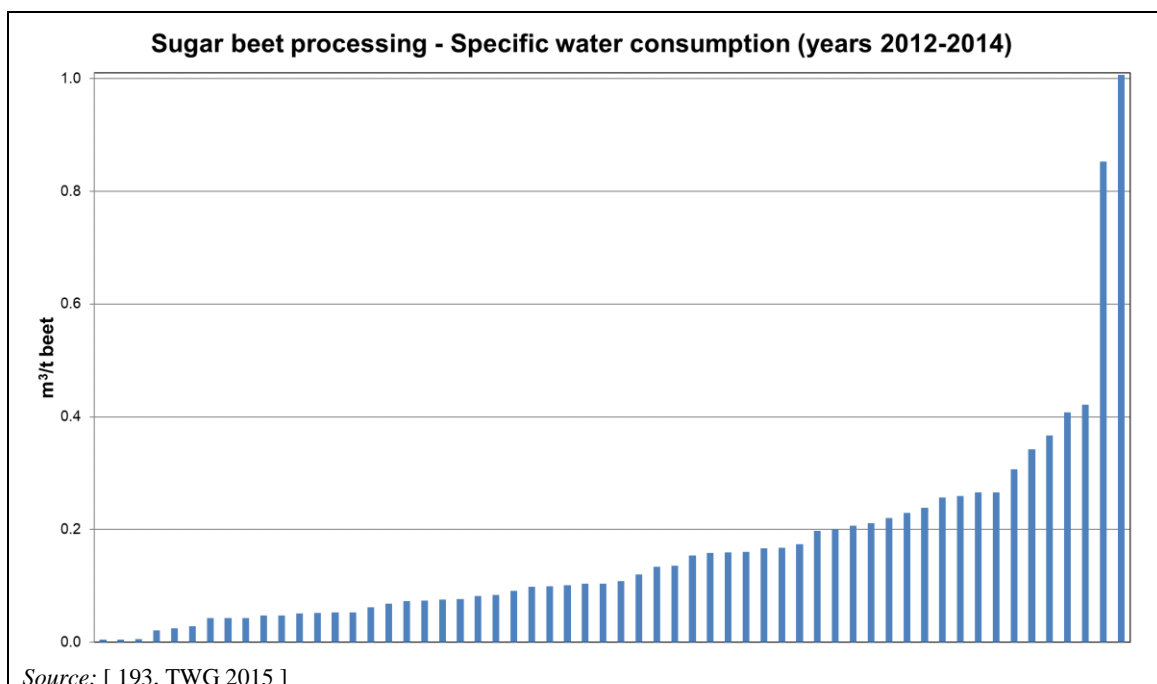

Figure 15.4: Specific water consumption (m^3/tonne of sugar beet) in sugar beet processing

15.3.1.3 Solid output

During the reception and fluming of the sugar beet, soil, stones, sand and vegetable matter, e.g. seeds, beet tails and leaves, are removed. The amount of the earth adhering to the beet may vary greatly depending, for example, on the weather conditions during harvesting and the design and operation of the harvester. In the annual processing of 500 000 tonnes of beets, an average of 60 000 tonnes of soil accumulates [51, Ullmann 2001]. The soil arriving at the installation is removed in settling ponds. The sediment may be reapplied to arable land or may be used for other purposes, such as horticulture or civil engineering works. The vegetable matter is separated from the fluming water for sale as animal feed or fertiliser.

The sugar content of the beets does not vary greatly, e.g. 18.4 % in Austria and 13.9 % in Greece [51, Ullmann 2001]. The efficiency of sugar extraction is about 90 %. There are a few by-products, such as beet pulp. After sugar is taken out, the extracted beet pulp is pressed. The wet pulp may then be dried. Beet pulp is normally sold as sweet feed for cattle. Another by-product is carbonatation lime. Juice purification is done using lime. It may be pressed and sold to de-acidify or balance the pH of soil.

Sugar beets contain some soluble non-sugar substances, 30–40 % of which are eliminated during purification of the juice with Ca^{2+} precipitable anions, pectins and proteins. The remainder is left in the juice and prevents the complete crystallisation of the sugar, leaving a final syrup, called molasses. This is the major single loss of sugar in the process. A total of 10–18 % of the sugar content of the beet is in molasses. About 38 kg molasses per tonne of sugar beet is generated. Molasses is about 80 % solid material and 20 % water.

In a study of Danish sugar factories, approximately 49 % of the total production was reported to be primary products such as sugar and molasses, while the remaining by-products such as lime, beet pulp and weeds were sold or reused [73, Nielsen et al. 2002]. Figure 15.5 shows a typical process flow diagram for a sugar beet processing installation [71, AWARENET 2002].

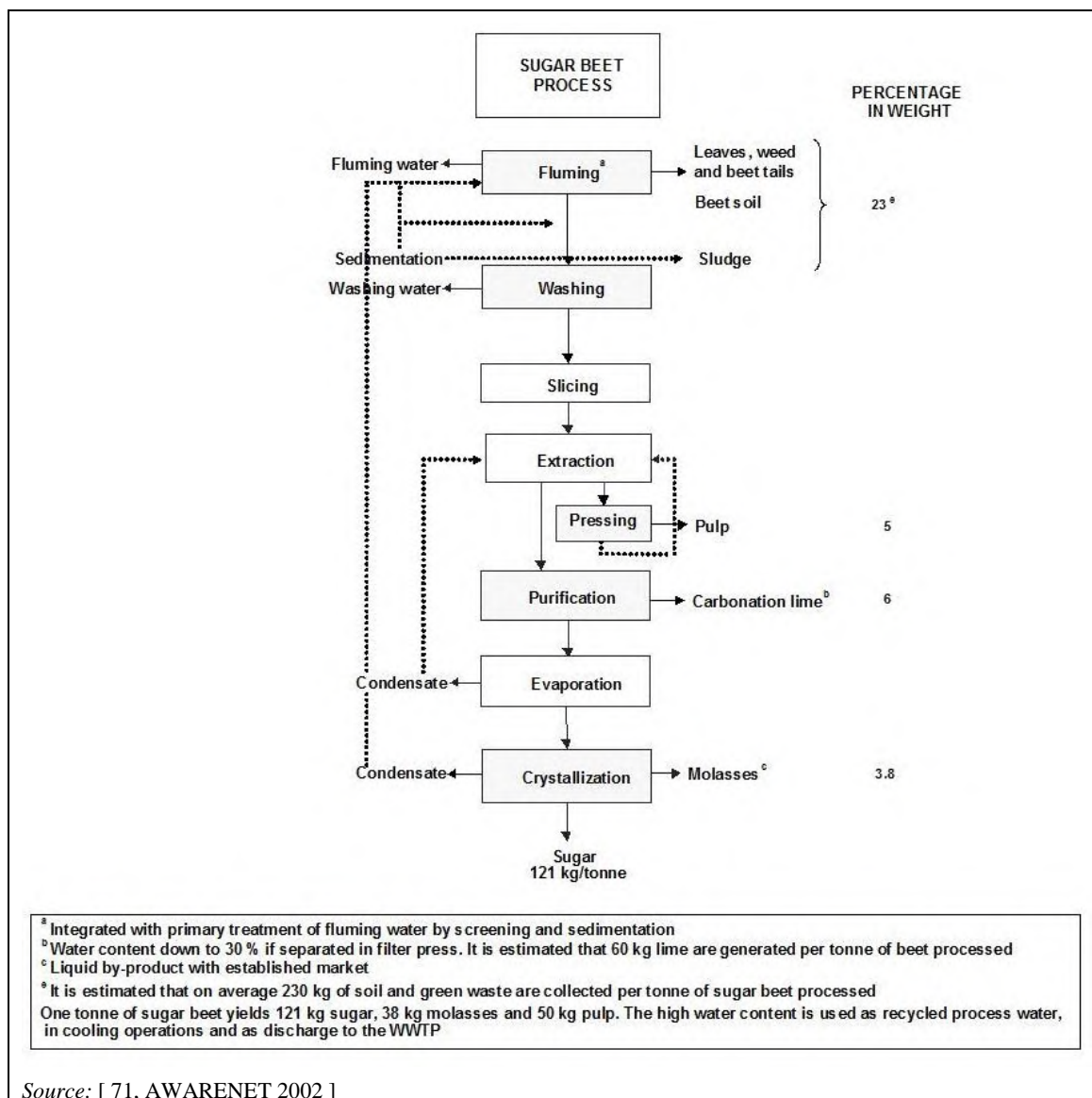

Figure 15.5: Major material streams during beet sugar production

15.3.1.4 Emissions to water

Sugar beet is 75 % water and the extraction process, by definition, aims to release a high proportion of the water contained in the beets. Approximately half of this water is lost due to evaporation or inclusion in various product streams. The remainder is, after usage for washing and fluming, a source of highly polluted waste water.

The beets are floated through the cleaning stage where stones, weeds and other gross contaminants are removed. The transport water pumped off with the soil sludge can be up to 70 % of the beet. It has high organic contamination due to the soil and sugar from damaged beets. Its COD is 5 000–20 000 mg/l.

The beets then enter the installation, where they are washed before being sliced into cosettes to maximise the surface area for the extraction process. The condensate from the evaporation and crystallisation stages is partly used as process water in several process stages, including beet washing. Process waste water is deemed to be the excess condensate from the concentration and crystallisation stages. This surplus condensate is high in ammonia and has a relatively low COD level. Waste water with high BOD levels is produced in large volumes [8, Environment Agency of England and Wales 2000] and is cleaned in a WWTP or is sent to landspreading as earthy water during the beet campaign or decanted water during the summer.

Figure 15.6 shows reported data on specific waste water discharge (m^3/tonne of sugar beet) in various sugar beet installations and all types of discharges. More information on emissions to water can be found in Section 2.2.3.

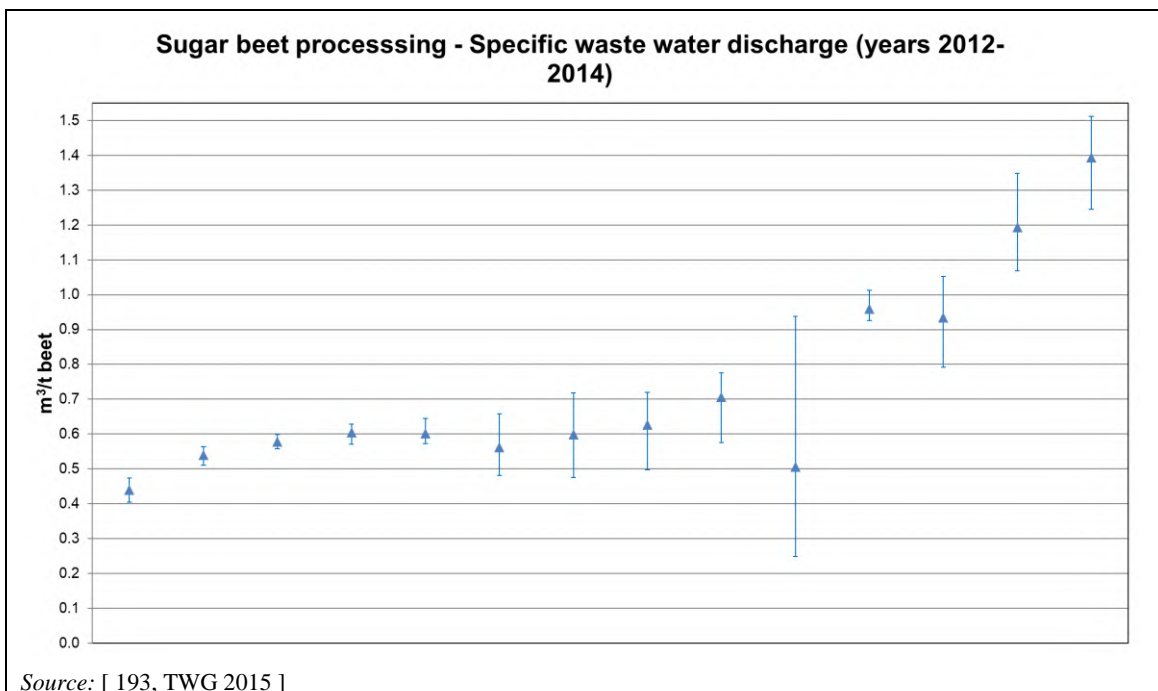

Figure 15.6: Specific waste water discharge (m^3/tonne of beet) from sugar beet processing for all types of discharges

15.3.1.5 Emissions to air from beet pulp dryers

15.3.1.5.1 Dust emissions

Cyclones are basically used as an abatement technique for dust emissions from dryers. Wet scrubbers are also applied, albeit less frequently. The emitted dust is reported to be very sticky. Dryers have been reported to operate at various O₂ levels, in many cases less than 10 %. A general overview of the data (concentration normalised at 16 % O₂) received for dust emissions from dryers is shown in Figure 15.7. The applied end-of-pipe abatement techniques are also indicated. Data are presented as reported (including wet and dry conditions). More information about wet and dry conditions is given in Table 15.3.

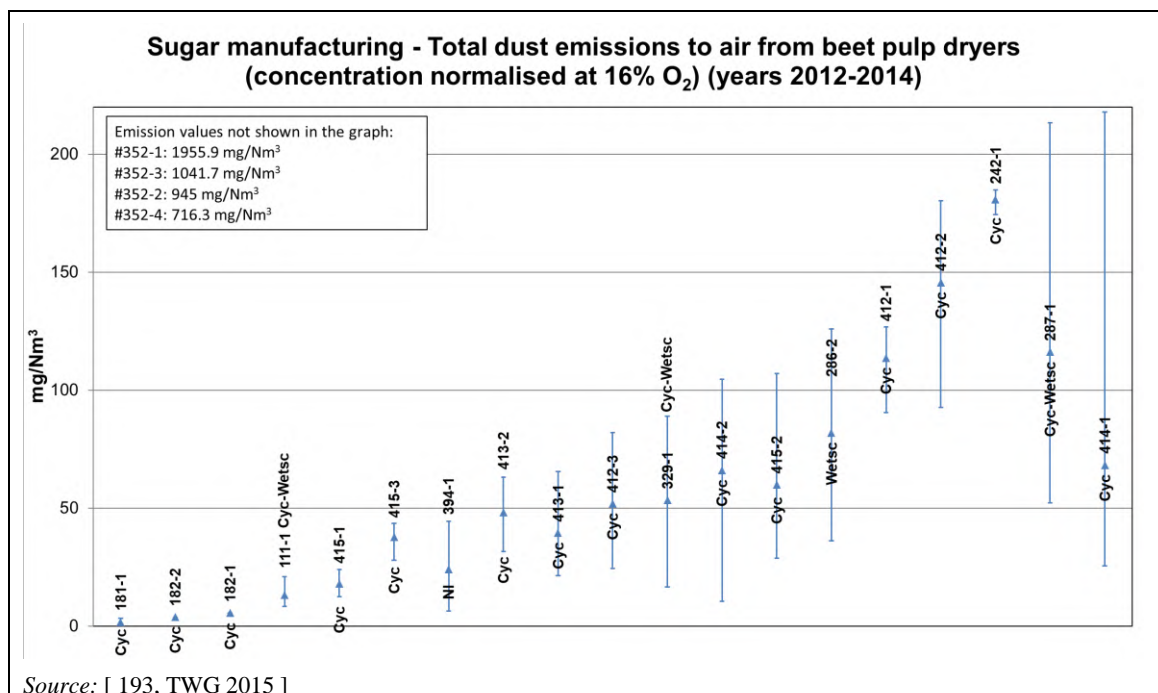

Figure 15.7: Total dust emissions to air from beet pulp dryers (concentration normalised at 16 % O₂)

The meaning of the symbols and abbreviations used in Figure 15.7 are indicated in Table 3.3 and Table 3.4.

15.3.1.5.2 TVOC emissions

Data from monitoring of stack TVOC emissions are shown in Table 15.1.

Table 15.1: Average TVOC emissions to air from a beet pulp dryer (spot sampling)

Installation ID-point of release	TVOC (mg/Nm ³)	O ₂ content (%)	Frequency of monitoring	Monitoring standard	Sampling duration (h)	Additional information
111-1	0.04*	7.93	Yearly	VDI 3481	0.50	High-temperature dryer/natural gas Central chimney Wet scrubber
112-2	0.08*	6.90	NI	VDI 3481	0.50	Rotary dryer with 3 drums using heat within hot gases from the CHP plant and additional production of heat from burning of biogas, natural gas and heavy fuel oil Cyclones (no abatement efficiency for TVOC)
288-1	181.30	13.00	Monthly	EN 12619	3.00	Rotary dryer/coal Wet scrubber Wet gas
287-1	192.00	15.86	Yearly	EN 12619	0.50	Rotary dryer/coal Wet scrubber Wet gas
286-2	235.00	15.80	Monthly	EN 12619	3.00	Rotary dryer/natural gas Wet scrubber Wet gas
* kg TOC/t of processed beet. NB: NI = no information provided. Source: [193, TWG 2015]						

15.3.1.5.3 NO_x emissions

A general overview of the data received for NO_x emissions from dryers is shown in Figure 15.8. For most of the release points, no technique for reduction of NO_x emissions has been reported. Data are presented as reported (including wet and dry conditions).

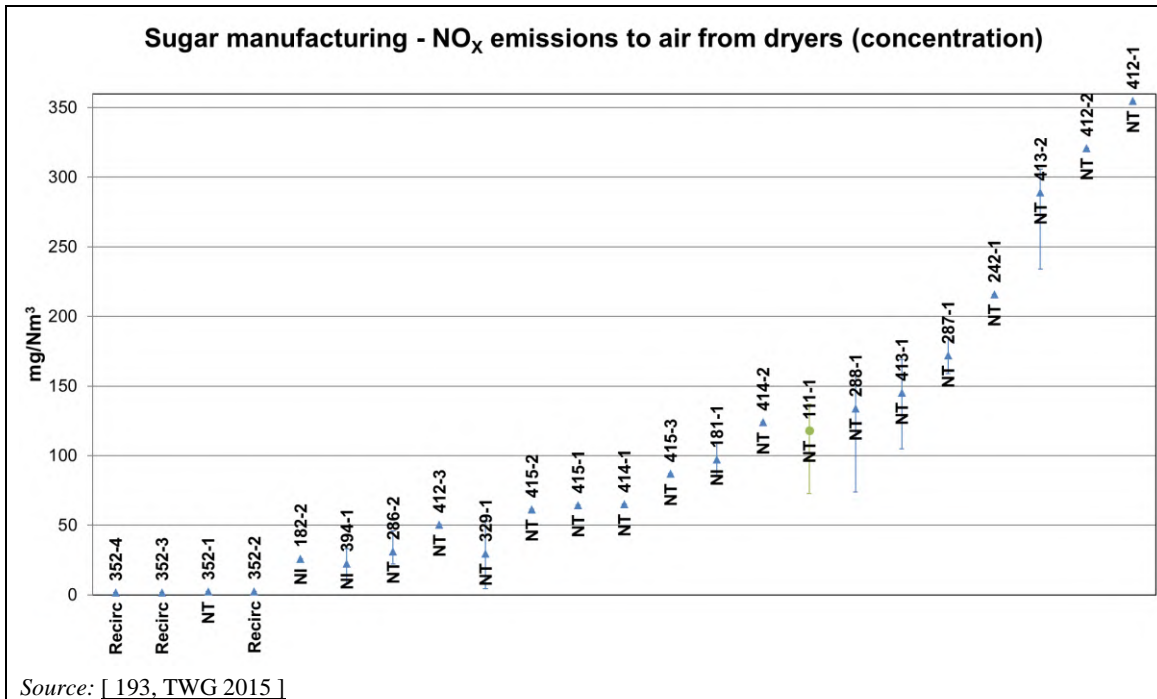

Figure 15.8: Average NO_x emissions to air from beet pulp dryers

The meaning of the symbols used in Figure 15.8 is indicated in Table 3.3.

15.3.1.5.4 CO emissions

A general overview of the data received for CO emissions from beet pulp dryers is shown in Figure 15.9. For all the release points, no technique for reduction of CO emissions has been reported. Data are presented as reported (including wet and dry conditions).

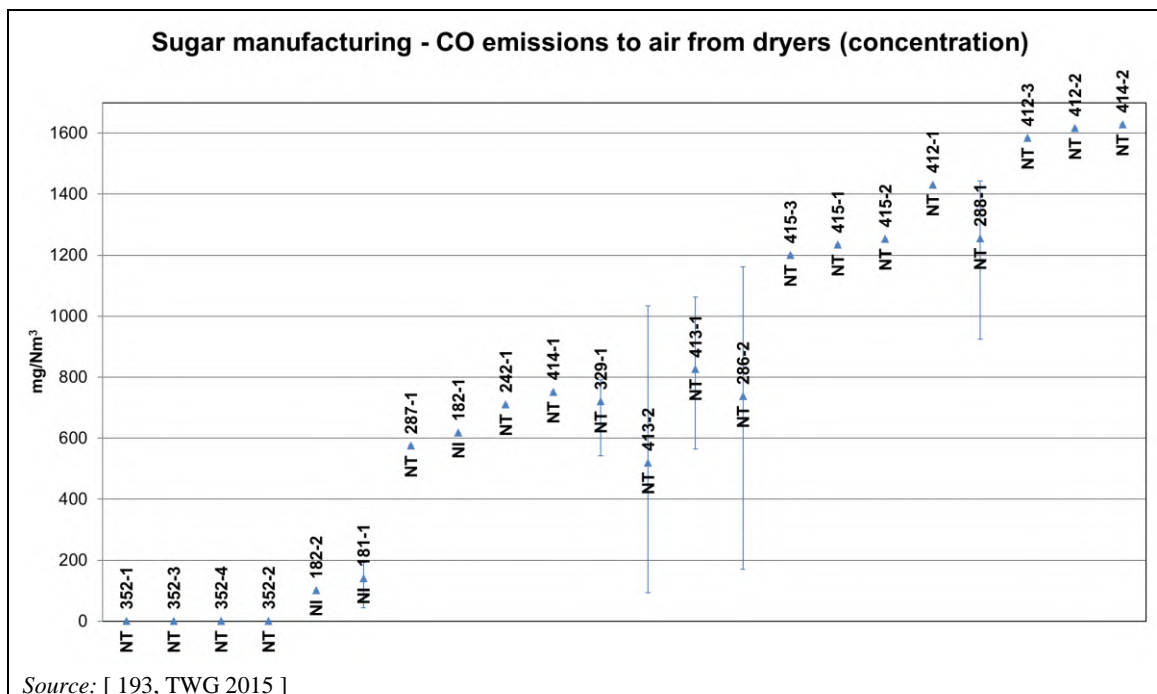

Figure 15.9: Total CO emissions to air from beet pulp dryers

The meaning of the symbols used in Figure 15.9 is indicated in Table 3.3.

15.3.1.5.5 SO_x emissions

A general overview of the data (concentration normalised at 16 % O₂) received for SO_x emissions from dryers is shown in Figure 15.10. For most of the release points, no technique for reduction of SO_x emissions has been reported. Data are presented as reported (including wet and dry conditions).

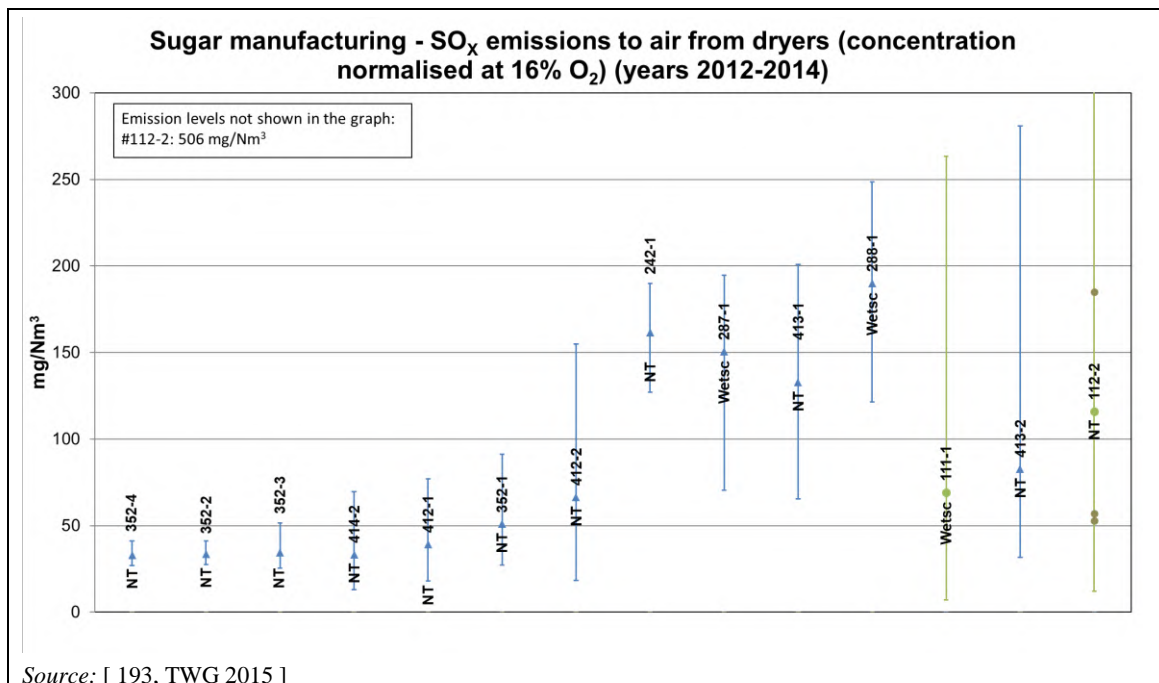

Figure 15.10: Average SO_x emissions to air from beet pulp dryers (concentration normalised at 16 % O₂)

The meaning of the symbols and abbreviations used in Figure 15.10 are indicated in Table 3.3 and Table 3.4.

15.3.2 Cane sugar refining

The starting point is not sugar cane, but raw sugar; therefore, less water is required than in sugar beet processing. The regeneration every 40–50 hours of the ion exchange resin cells used in the decolourisation process generates a difficult waste water as caustic brine is used as the regenerant [8, Environment Agency of England and Wales 2000]. There may be excess condensate and sweet water although these can be eliminated (see Section 15.4.2.1). Waste water is generated from the steam-cleaning of the bulk road tankers used to transport liquid sugar products.

In general, cane sugar refining demands more specific water and energy consumption and generates more specific waste water discharge than sugar beet processing [193, TWG 2015].

Total dust emissions to air from handling and preparation of raw materials in cane sugar refining are shown in Figure 15.11. The received data are related to three installations (#328, #329 and #373). Emission points include releases from silos, transportation and packaging areas. Bag filters are commonly used as the final abatement technique.

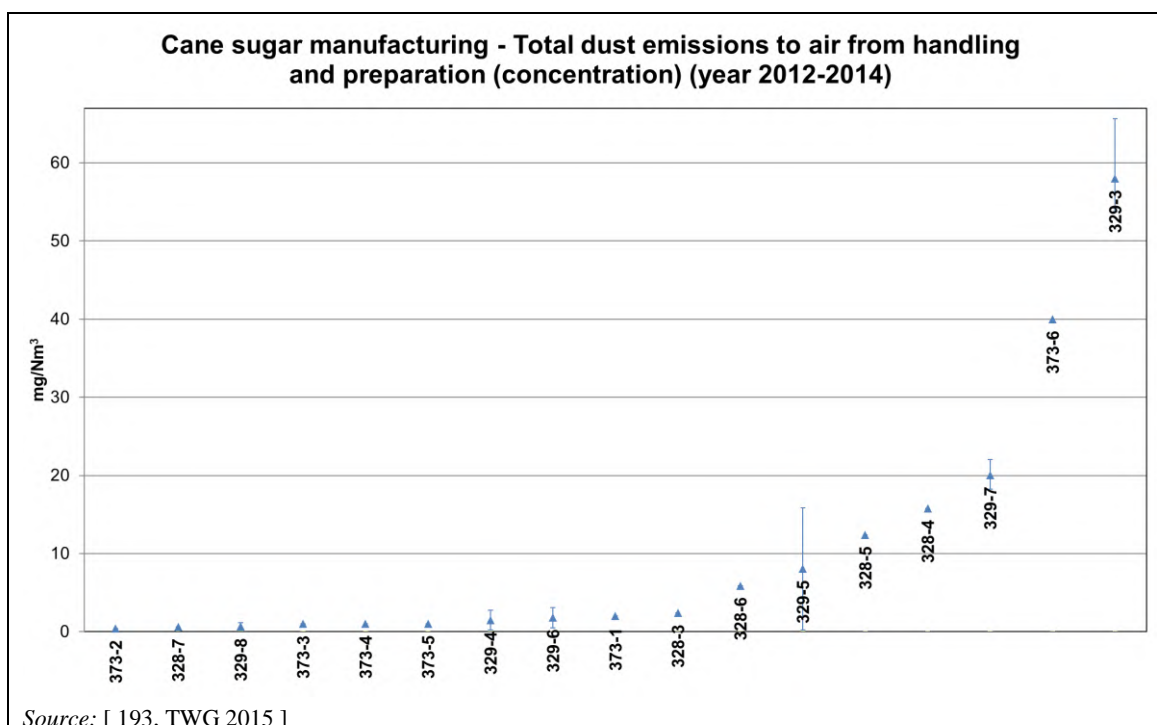

Figure 15.11: Total dust emissions from handling and preparation of raw materials in cane sugar refining

The meaning of the symbols used in Figure 15.11 is indicated in Table 3.3.

15.4 Techniques to consider in the determination of BAT

15.4.1 Techniques to increase energy efficiency

15.4.1.1 Pressing of sugar beet pulp

Description

The beet pulp is pressed to a dry matter content of typically 25–32 %.

Technical description

Pressed beet pulp typically contains 20–32 % dry matter and could be a valuable feed and is generally considered as a non-forage fibre source.

Achieved environmental benefits

Reduced energy consumption for beet pulp drying.

Environmental performance and operational data

No information provided.

Cross-media effects

No information provided.

Technical considerations relevant to applicability

Pressed pulps can only be stored for a few days, unless made into silage.

Economics

No information provided.

Driving force for implementation

Drying the pulp produces animal feed that can be stored for a longer time.

Example plants

Used in various sugar plants.

Reference literature

[234, Denmark 2015]

15.4.1.2 Indirect (steam drying) of beet pulp

Description

Drying of beet pulp by the use of superheated steam.

Technical description

Drying is achieved by using superheated steam. If the steam is at 130 °C, it expands and the temperature drops to 102–103 °C at around 0.1 MPa by the uptake of water. If the steam is at 260 °C at around 2.6 MPa, it expands and the temperature drops to 148 °C at around 0.37 MPa. Fluidised bed dryers (FBDs) can be used in steam drying.

Achieved environmental benefits

Benefits include low emissions of dust and odour. As hot gas is not used, NO_x is not released. An additional advantage compared to the high-temperature drying (HTD) and two-stage drying is the lower overall energy consumption. The energy output, e.g. steam, can be reused in the sugar extraction process. Drying the pulp produces animal feed that can be stored for longer than moist feed.

Environmental performance and operational data

The closed design of the steam dryer system has the advantage that the dust, odour and vented gases are controlled and can be eliminated. Almost all dust generated during the drying process is trapped in the dried pulp and becomes part of this. Only a minor amount leaves the dryer with the steam evaporated from the beet pulp. Odour is normally released with the gases vented following condensation of the steam generated in the sugar juice evaporation process. The odorous gas can be sent to the boilers for incineration or for removal in a small scrubber. When cooled below 20 °C, the amount of non-condensable gasses is 100–200 m³/h.

In the case of steam dryers, the water content of the exhaust gas (which is steam) is normally used for driving the first step in the juice evaporator/concentrator, where the steam condenses as it releases the energy used for driving the evaporator. About 0.6–0.7 tonnes of condensate are generated per tonne of pressed pulp with an organic load in the condensate of 0.20–0.25 kg TOC per tonne of pressed pulp. The condensate with the organic load will either be reused by reclaiming part of the energy (heat) before being used in the diffuser or be treated in the waste water treatment plant.

In more detail, the energy in the hot condensate can be partly reclaimed via a heat exchanger by using it to preheat the juice to be concentrated. The condensate itself is cooled from 130 °C to 60 °C. The cooled condensate at 60 °C and with a pH of 4.5 can then be used in the diffuser or be directed to the waste water treatment plant [17, TWG 2018].

If the cooled condensate is added at the pulp exit end of the diffusor, the pH at 4.5 will facilitate the following pressing of the wet pulp in the screw presses and in this way reduce the amount of water to be evaporated in the beet pulp dryer. Alternatively, the cooled condensate can go directly to the waste water treatment plant. The temperature of 60 °C and the content of acetic acid can improve the efficiency of the waste water treatment plant. This effect will be increased slightly if the condensate is sent directly to the waste water treatment plant after the juice evaporating process.

A significant advantage of using steam drying is the potential for reusing the energy used for the drying of the beet pulp. This also means that the installation of a steam dryer is normally only feasible if a consumer for the generated steam is available, like in a sugar plant.

In a pressurised steam fluidised bed dryer reactor, the steam drying of the beet pulp takes place in a closed fluidised bed system which allows for almost all the remaining energy to be used for the drying process. The steam generated by the drying process (evaporated from the beet pulp) is used in the sugar factory.

The pressurised steam fluidised bed dryer makes use of the availability of high-pressure superheated steam in the factory. The energy potential of the HP steam is used to dry the pulp under a relatively low pressure of 3.5 bar and 150 °C in a closed pressure vessel. This method of drying needs a high-intensity contact between the pulp and the steam. This is achieved in a fluidised bed, where the pulp is kept in suspension by the circulating steam. As the pulp particles are dried to the desired moisture content, they will be conveyed out of the dryer by a screw conveyer.

The operating principle of the pressurised steam fluidised bed dryer is shown in Figure 15.12.

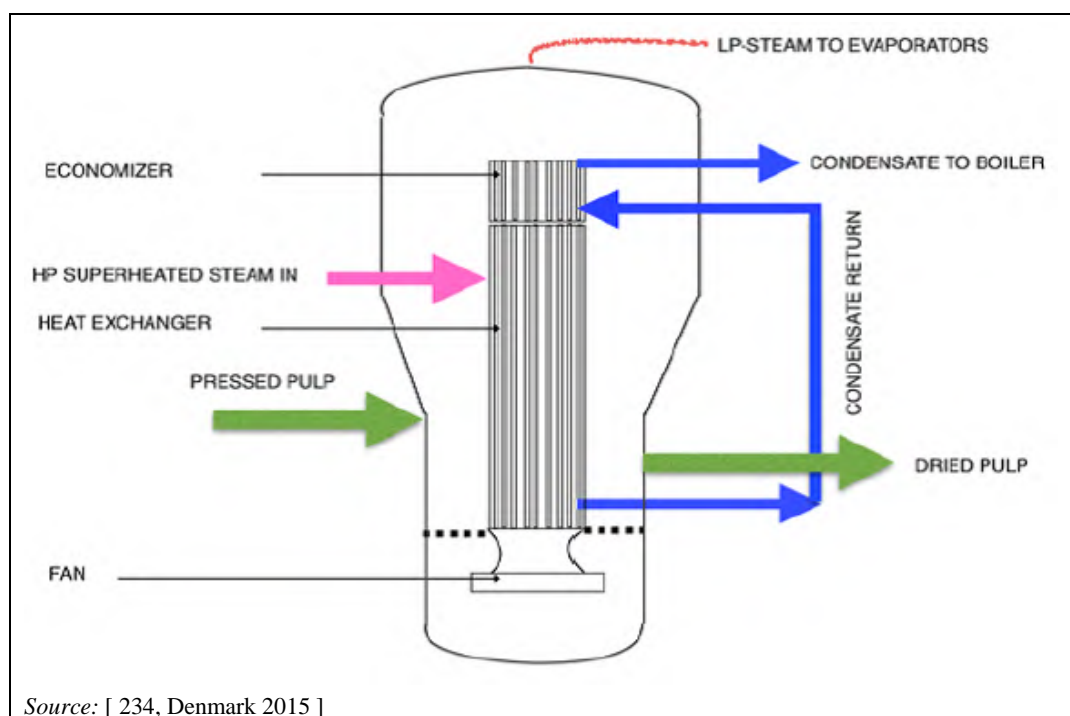

Figure 15.12: Pressurised steam fluidised bed dryer

Three main streams leave the dryer:

- the product, the dried beet pulp;
- the steam from the water evaporated from the pressed pulp; this is used as an energy source elsewhere in the sugar installation, i.e. in the juice evaporation/concentration process;
- the condensate from the steam used for running the dryer; this goes into the normal condensate system of the installation and is returned to the boiler.

Due to the controlled modest temperature of the technique, when drying the beet pulp, the raw beet pulp is basically boiled during the early stages of the drying process. This has a positive impact on its digestability for high-yielding dairy cows.

Cross-media effects

No information provided.

Technical considerations relevant to applicability

The technique may not be applicable to existing plants due to the need for a complete reconstruction of the energy facilities. Steam drying is integrated into the steam system of the sugar installation. The steam drying system can, without any complications, be integrated into new sugar installations. For existing installations, the level of complexity varies from plant to plant. It will require smaller or larger modifications to the existing systems and may require complete reconstruction of the energy generation and heat-switching facilities. Retrofitting can involve the reconstruction of the steam generation and electricity production sections including, for example, revising the entire heat transfer arrangements within the installation.

Economics

Costs are site-specific and differ for new and existing plants. Steam drying with FBDs and two-stage drying have practically the same net present value, while HTD is about 6 % cheaper. However, if the calculations are done with a longer operational life, i.e. 18 years, for the dryers and the gas turbine, the net present value of steam drying with FBDs is the lowest, e.g. lowest cost [35, Germany 2002].

Driving force for implementation

- Savings in costs and energy.
- Drying the pulp produces animal feed that can be stored for longer than moist feed.
- Reduced dust and odour emissions to air.

Example plants

Used in various sugar plants across Europe (e.g. in Germany, France, Sweden), the USA, Japan, Serbia and Russia.

Reference literature

[17, TWG 2018], [35, Germany 2002], [98, TWG 2017], [233, Denmark 2015], [234, Denmark 2015]

15.4.1.3 Solar drying of sugar beet pulp**Description**

Use of solar energy to dry the beet pulp.

Technical description

Pulp solar drying uses solar energy to dry the beet pulp, which allows the energy consumption of the traditional pulp dryer to be decreased. Due to this new technology, the pulp dryers can be turned off.

The solar drying process usually begins during the summer campaign as follows:

- pressed pulp loading is transported to the drying area;
- pulp is spread in the drying field (normally a concrete field);
- the pulp is stirred and turned over;
- dried pulp is picked up and transported to a pelletisation area.

In some cases, the pressed pulp is ensiled during the autumn/winter campaign, and, when the meteorology conditions are favourable, the pulp is transported to the drying area. Ensiling may also be applicable before the final pelletisation.

Achieved environmental benefits

Stopping the conventional pulp dryer results in a significant decrease in gas and electricity consumption and CO₂, particles and odour emissions.

Environmental performance and operational data

The technique has been implemented in some sugar installations in Spain and the quality of the dry pulp is controlled according to specific plans. The final results are of good quality. The yield of solar drying can be between 50 t/ha-day and 80 t/ha-day, depending on the weather conditions (e.g. wind and relative humidity of the air) and the operating conditions (e.g. spreading time and thickness) [170, COM 2015].

A reduction of about 15–25 % of the total fuel consumption (natural gas) can be achieved, resulting in about 10 000–15 000 tonnes less of CO₂ being emitted (#181 and #182). Normally, there are no significant dust and odour emissions when using this technique.

Cross-media effects

It requires extra resources for spreading the pulp (staff, specific machinery and fuel).

Technical considerations relevant to applicability

May not be applicable due to local climatic conditions and/or lack of space.

Economics

Costs of around EUR 2 million (mainly construction cost of concrete area) for a drying area of 14 ha.

Driving force for implementation

Reduction in CO₂ footprint and in the energy costs of the installation.

Example plants

Sugar installations in Spain.

Reference literature

[170, COM 2015], [193, TWG 2015]

15.4.1.4 High-temperature drying of sugar beet pulp

Description

The drying gas, e.g. air or hot gas, has a temperature between 500 °C and 1 000 °C.

Technical description

In high-temperature drying (HTD), dryers generally operate between 500 °C and 1 000 °C by direct firing to maximise evaporation efficiency and product throughput (below 900 °C the efficiency is reduced), and are then cooled to approximately 100 °C by evaporation of water from the pulp in the dryer. Co-currently operated rotary drum dryers with preceding firing are used for drying pressed pulp. Pressed pulp enters a slightly inclined rotating drum. Hot air (produced from the combustion of gas, oil or coal) is passed co-currently through the drum. The action of the drum and the hot gases cause the pulp to pass through the drum. The dried pulp passes to a conveying system at the end of the drum.

The drying gas used can be a mixture of firing gas which is formed during the combustion of fuel in the dryer firing system; recycled dryer hot gas; boiler hot gas from steam generation; and a small proportion of ambient air which is drawn into the drum due to the design of the system. Cooling air is used in exceptional cases only. The hot gas from the steam generation is, apart from the molasses-treated pulp, the sole connection between the drying unit and the rest of the sugar installation.

In the drying process, the firing gas accounts for about 25 % of the stream mass and about 75 % of the stream energy. The steam generator hot gas supplies about 70 % of the stream mass to the hot gases and about 25 % of the stream energy for the drying gases.

Achieved environmental benefits

Drying the pulp produces animal feed that can be stored for longer than moist feed.

Environmental performance and operational data

The amount of heat required for the evaporation of 1 kg of water depends on the temperature gradient between the inlet and outlet of the drum. The higher the combustion gas temperature at the inlet of the drum, the greater the thermal efficiency of the equipment. Typically, drying at temperatures of up to 750 °C is considered to be HTD, except in the UK, where drying is carried out at 950 °C. It is reported that this gives a 15–18 % benefit in energy efficiency compared to drying at 750 °C. However, excessively high entrance temperatures may lead to strong scaling of the internal parts and burning of the material to be dried. For inlet temperatures of 600 °C, approximately 0.972 kWh (3 500 kJ) per kilogram of water to be evaporated are used. In the drums, 150–180 kg of water evaporates per hour per cubic metre of drum contents. At the end of the process, the temperature of the drying gas is around 100 °C. The material being dried has a temperature of 60–70 °C during the drying process [192, COM 2006].

When hot gas is used for drying, NO_x and SO_x are released. The emission level of NO_x and SO_x within the hot gas is a function of the type of fuel, the burner type, primary, secondary and tertiary air split and the location of any recycled exhaust gases used. For example, in five German sugar production installations using natural gas, the average NO_x content was about 70 mg/Nm³ in the exhaust gas and in 12 sugar installations using heavy fuel, it was about 270 mg/Nm³. The organic compounds emissions were about 50–600 mg/Nm³ and the CO emissions were about 210–1 050 mg/Nm³. The dust concentration in the air after cyclone treatment of the five sugar installations using natural gas was about 35 mg/Nm³, while two factories using coal for their boiler and heavy oil/natural gas for the drying had an average dust concentration of about 82 mg/Nm³. Emissions of 50–60 mg/Nm³ wet dust and 0.08 kg TOC/t of sliced beet have been reported from Germany, measured under reference conditions (12 vol-% O₂ content of air). The dust in the exhaust air of a dryer also depends on the moisture content of the dried pulp. A solid content above 91 % may lead to higher dust in the air. The solid content needs to be higher than 86 % because a higher moisture content can reduce the biological stability of the pulp [192, COM 2006].

The major environmental issue is the energy consumption. The energy consumption may be reduced by reducing the initial water content of the beet pulp. When the dry solid content of the pulp after pressing is 25 %, 2.6 tonnes of water per tonne of dried pulp has to be evaporated in the drying process to achieve 90 % solids content. When the pressed or predried pulp has 35 % solids, only 1.6 tonnes of water needs to be evaporated to produce one tonne of dried pulp. With lower amounts of water to be evaporated, lower amounts of air or hot gas are needed and consequently lower amounts of condensed water are generated. In consequence, less air and waste need to be treated [192, COM 2006].

High-temperature dryers can dry other products besides sugar beet pulp during campaign and inter-campaign periods (e.g. alfalfa or other green fodder) [98, TWG 2017].

Cross-media effects

Energy is consumed. Waste water is produced if condensation of waste gas is applied. Dust and odour are emitted to air. NO_x, CO and organic compounds are emitted when hot gas is used. Depending on the type of fuel used, some contamination of the dried pulp can occur when drying with flue-gases.

Technical considerations relevant to applicability

HTD is the most commonly used technique in Europe. It is applicable for drying pulp in the sugar sector. This technique can be operated independently of the method of operation of the sugar installation and the steam generators.

Economics

A total investment cost of around EUR 10 million for a HTD plant has been reported, based on a standard sugar factory with a daily intake of 10 000 tonnes of beets.

Driving force for implementation

Drying the pulp produces animal feed that can be stored for longer than moist feed.

Example plants

Used in most of the EU sugar installations.

Reference literature

[17, TWG 2018], [35, Germany 2002], [51, Ullmann 2001], [98, TWG 2017], [192, COM 2006], [193, TWG 2015], [234, Denmark 2015]

15.4.1.5 Low-temperature drying of sugar beet pulp

LTD dryers commonly used are belt dryers at ambient oxygen content. Their position in the different existing process setups will depend on specific technical choices made at site level and on the energy used [301, CEFS 2018].

15.4.1.5.1 Low-temperature (pre)drying of sugar beet pulp

Description

Direct (pre)drying of beet pulp using drying gas, e.g. air or hot gas.

Technical description

Low temperature drying (LTD) is normally used as a preliminary step before HTD in the two-stage drying of sugar beet pulp. In LTD of sugar beet pulp, large quantities of drying gas, e.g. air or hot gas, with an inlet temperature of about 50 °C, are saturated. The outlet temperature is about 25–30 °C. Belt dryers are used for LTD.

For production of molasses, molasses are mixed with the pulp, before the whole mixture is dried. LTD is used as a first step to make use of the lower-energy heat from the HTD step and from the sugar production processes to increase the overall energy efficiency of the sugar beet factory.

Achieved environmental benefits

The energy consumption and air pollution are reduced compared to stand-alone HTD. By reclaiming low-value energy, the amount of energy used for the final HTD is reduced. Drying the pulp produces animal feed that can be stored for longer than moist feed.

Environmental performance and operational data

If two-stage drying is applied, about 30 % energy can be saved by using the vapours of the HTD step for the first step, LTD. Most belt dryers operate with hot air at approximately 60 °C, which can be heated using the heat streams from the evaporation station and crystallisation unit of the sugar installation, which would otherwise be lost to the environment as waste heat.

Table 15.2 shows examples of the air states for LTD and HTD of sugar beet pulp.

Table 15.2: Characteristic LTD and HTD of sugar beet pulp

Parameters of the drying gas		LTD			HTD		
		In	Out	Δ	In	Out	Δ
Temperature	°C	50	25	25	750	102	648
Relative humidity of the gas	%	9.0	88.6	79.6	*	33.1	NI
Water vapour load	kg/kg	0.0070	0.0181	0.0111	0.0366	0.3508	0.3142
Enthalpy of moist air in relation to dry air	kJ/kg	68.8	71.1	2.3	983.2	1049.8	66.7
Enthalpy of moist air in relation to dry air	kWh/kg	0.019	0.020	0.001	0.273	0.292	0.019
Air/water evaporated ratio	kg/kg	$1/\Delta y = 0.0111^{-1} = 89.9$			$1/\Delta y = 0.3142^{-1} = 3.2$		
* Not defined because critical temperature exceeded.							
NB:							
Δy: increase of the function.							
NI = no information provided.							
Source: [35, Germany 2002]							

The waste water produced by the condensation of the vapours created at the HTD step is either sent to a WWTP or for landspreading.

Cross-media effects

Dust and odour are emitted. NO_x, CO and organic compounds are emitted when hot gas is used. Waste water is produced.

Technical considerations relevant to applicability

Applicable for drying molasses-treated pulp in the sugar sector. The implementation of a combination of LTD and HTD for pulp drying is strongly dependent on specific conditions. If there is no market for the dried pulp, or if the pressed pulp is used for biogas production or directly distributed as feed, or if some other technology for pulp drying is chosen, this technique would not be economically viable [193, TWG 2015].

Economics

Lower energy demand than stand-alone HTD.

Driving force for implementation

Increase of the overall energy efficiency of a sugar beet factory.

Example plants

Various plants in Europe (e.g. in Austria, Germany). Plants #014, #015 and #112-1 in the FDM data collection.

Reference literature

[4, CEFS 2018], [35, Germany 2002], [193, TWG 2015]

15.4.1.5.2 Other uses of LTD dryers**Description**

LTD dryers are used as post-dryers or parallel dryers with a direct or indirect link to a HTD dryer.

Technical description

Belt LTD dryers can also be used as post-dryers or parallel dryers with a direct or indirect link to a HTD dryer. This setup also allows the use of the installation to dry other materials besides beet pulp. These configurations have been reported in many sites in France. Configuration choice depends on the technical choices of the companies and the evolution of available techniques. Typical configuration choices could be summarised as follows:

- Belt dryer operated in parallel with a high-temperature dryer (separate beet pulp flows), which uses hot air generated by hot gas from the associated high-temperature dryer (installation #287). The typical inlet air temperature is between 70 °C and 80 °C and the typical outlet air temperature between 25 °C and 40 °C.
- Post-dryer with hot air.

To summarise, belt dryers are used to allow flexible feed drying within the sugar beet factory:

- as dryers or post dryers;
- with hot gas or hot air at a temperature between 50 °C and 130 °C (especially in the case of a belt dryer).

Achieved environmental benefits

Energy consumption and emissions to air are reduced compared with stand-alone HTD. Drying the pulp produces animal feed that can be stored for longer than moist feed.

Environmental performance and operational data

Dust emissions measurements in the belt dryer of installation #287 (this dryer was not part of the FDM data collection, measurements were provided afterwards for the years 2016 and 2017) showed values between 10 mg/Nm³ and 20 mg/Nm³ (at 21 % O₂, wet basis).

Cross-media effects

NO_x, CO and organic compounds are emitted when hot gas is used. Waste water is produced in the case of LTD using hot air.

Technical considerations relevant to applicability

The implementation of the technique is strongly dependent on specific conditions. If there is no market for the dried pulp, or if the pressed pulp is used for biogas production or directly distributed as feed, or if some other technology for pulp drying is chosen, this technique would not be economically viable.

Economics

Lower energy demand than stand-alone HTD.

Driving force for implementation

Increase of the overall energy efficiency of a sugar beet factory. These types of dryers can be a solution to improve drying capacity while avoiding complete restructuring of factory (change of drying installation, e.g. HTD or steam).

Example plants

Installation #287.

Reference literature

[4, CEFS 2018]

15.4.1.6 Recycling of hot gases

Information on this technique is available in Section 3.4.1.2.

Description

Recycling of hot gases (e.g. waste gases from the dryer, boiler or combined heat and power plant).

15.4.2 Techniques to reduce water consumption

15.4.2.1 Water recycling

See also Section 2.3.3.1.1.

Description

Recycling or reuse of water streams (preceded or not by water treatment), e.g. for cleaning, washing, cooling or for the process itself.

Technical description

For sugar beet processing, one of the major sources of waste water is the flume water used for transporting beet through the initial stages of the process. The flume water can be reused approximately 20 times before it is disposed of. The ultimate goal for consumption of transport water may be zero extraction from external water sources.

On many sites, transport water is reused in extensive circuits, usually only after intermediate purification via settling ponds. Due to the formation of organic acid compounds within the flume water, historically the practice has been to correct the pH, usually with lime. Installations using biological treatment for waste water have, however, found that the need for pH correction has been eliminated. If care is taken to minimise beet damage during transport, this reduces sugar leaching into the transport water and consequently reduces the COD levels and the extent of waste water treatment before reuse.

It is reported that in most cases it is feasible, assuming there is enough storage capacity, to retain enough water from the previous year's campaign to start the new campaign. This prevents the need to extract water from a river or underground sources. Surplus water that cannot be used for the next campaign is discharged into an outlet leading to a watercourse. Some installations send the mixture of soil and water for landspreading.

Condensate from the evaporation and crystallisation stages is partly used as process water in several stages, including beet washing. Condensate may also be considered as a source of low-grade water. For example, it is reported that sugar refineries can be made very water-efficient so that all the fresh water is used in the process and total recycling of condensate is achieved. Sugar beet is 75 % water and the extraction process, by definition, aims to release a high proportion of that water. Approximately half of this water is lost due to evaporation or is included in various product streams.

Achieved environmental benefits

Reduced water consumption.

Environmental performance and operational data

Water consumption values below 0.20 m³/t of beet processed have been reported in most cases.

Cross-media effects

No information provided.

Technical considerations relevant to applicability

Applicable in installations producing sugar from sugar beet.

Economics

No information provided.

Driving force for implementation

Reduced environmental impact by limiting need for new water. Reduced costs associated with waste water treatment.

Example plants

Applied in many installations producing sugar from sugar beet.

Reference literature

[1, CIAA 2002], [8, Environment Agency of England and Wales 2000], [31, CEFS 2001], [71, AWARENET 2002]

15.4.3 Techniques to reduce waste

15.4.3.1 Reduction of sugar beet soil tare

Description

By a combining technical, economic and plant breeding measures, the amount of solids delivered to the installation is reduced.

Technical description

Large quantities of soil, gravel and stones are transported to sugar factories as part of beet deliveries. Handling of this unwanted material consumes a lot of resources at the site, e.g. energy and water. A clean beets project, combining technical, economic and plant breeding measures, can reduce the amount of soil delivered to the installation.

Achieved environmental benefits

Reduced amount of waste and reduced water and energy consumption.

Environmental performance and operational data

A Swedish example sugar beet installation has focused on reducing soil tare since the early 1980s. A clean beets project has resulted in a reduction of soil tare of 150 000 tonnes. In Denmark, the reported figure is even higher due to a larger beet growing area. Performance levels are now 50 % below those typical 10 years ago.

In addition, a special bonus system is used in Sweden and Denmark to promote harvesting in good weather conditions and the optimal use of harvesters. Tests run at an example installation indicate that, once new harvesters are used appropriately, it is possible to achieve a 5 % soil tare (95 % purity) under almost all weather conditions. Figure 15.13 shows the reduction of soil tare in Sweden.

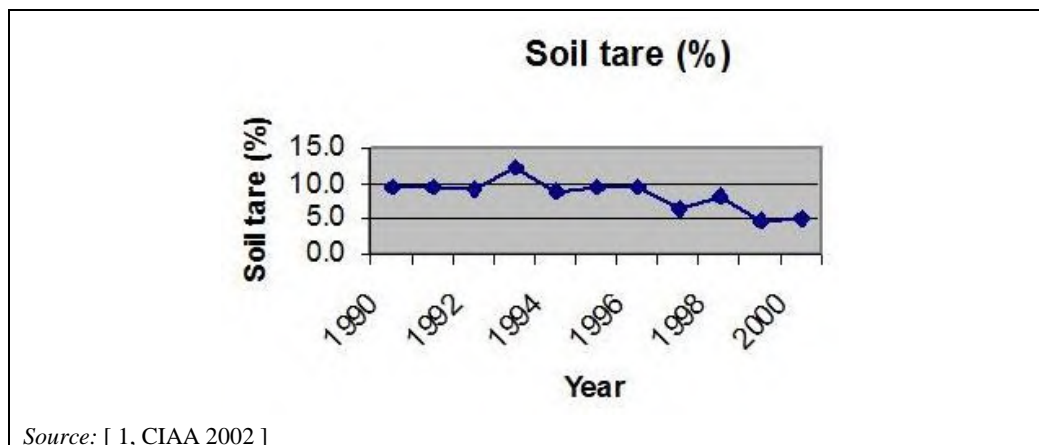

Figure 15.13:Reduction of soil tare in Sweden

Parallel to this work, these installations are working on improving the shape of sugar beets to ensure that less soil attaches to the tuber. Breeding using traditional breeding techniques has focused on the root groove of the beet, which is the main problem in beet washing.

Cross-media effects

No information provided.

Technical considerations relevant to applicability

Applicable in sugar manufacturing.

Economics

Reduced energy and water costs.

Driving force for implementation

Reduced energy and water costs.

Example plants

Sugar manufacturers in Sweden, Denmark and Germany.

Reference literature

[1, CIAA 2002]

15.4.4 Techniques to reduce emissions to air

15.4.4.1 Reduction of dust emissions from beet pulp dryers

15.4.4.1.1 Cyclone

The technique is generally described in Section 2.3.7.2.3.

Environmental performance and operational data

Table 15.3 shows installation-specific performance data related to the application of cyclones as the dust abatement technique.

Table 15.3: Total dust emissions to air from a beet pulp dryer after treatment in a cyclone

Installation ID-point of release	Dust (mg/Nm ³)	O ₂ content (%)	Monitoring standard	Frequency of monitoring	Additional information
181-1	7.00	10.00	NI	Monthly	HTD Natural gas
182-2	13.70	3.00	NI	Three measurements per campaign	HTD Natural gas
415-1	20.40	12.80	EN 13284-1	Yearly	Rotary dryer/natural gas Very sticky dust Wet gas Dust fraction is 45.5 % PM ₁₀ and 24.4 % PM _{2.5}
415-2	30.40	15.70	EN 13284-1	Yearly	Rotary dryer/natural gas Very sticky dust Wet gas Dust fraction is 45.5 % PM ₁₀ and 24.4 % PM _{2.5}
414-1	40.50	17.40	EN 13284-1	Monthly	Rotary dryer/natural gas Very sticky dust Dust fraction is 46.5 % PM ₁₀ and 37 % PM _{2.5}
413-2	50.50	15.40	EN 13284-1	Monthly	Rotary dryer/fuel oil Very sticky dust Dust fraction is 55 % PM ₁₀ and 20 % PM _{2.5}
412-3	73.80	16.50	EN 13284-1	Yearly	Rotary dryer/natural gas Very sticky dust Wet gas Dust fraction is 36.30 % PM ₁₀ and 32.70 % PM _{2.5}
352-1	75.50	15.89	PN-Z-04-30-7	Yearly	Drum dryer/coal
352-2	80.70	15.47	PN-Z-04-30-7	Yearly	Drum dryer/coal
413-1	103.00	7.50	EN 13284-1	Monthly	Rotary dryer/coal Very sticky dust Dust fraction is 55 % PM ₁₀ and 20 % PM _{2.5}
412-1	104.00	16.90	EN 13284-1	Yearly	Rotary dryer/coal Very sticky dust Wet gas Dust fraction is 36.30 % PM ₁₀ and 32.70 % PM _{2.5}
414-2	134.00	14.00	EN 13284-1	Monthly	Rotary dryer/coal Very sticky dust Dust fraction is 46.4 % PM ₁₀ and 23.5 % PM _{2.5}

Source: [193, TWG 2015]

Reference literature

[193, TWG 2015]

15.4.4.1.2 Wet scrubber

The technique is generally described in Section 2.3.7.3.1.

Environmental performance and operational data

Table 15.4 shows installation-specific performance data related to the application of a wet scrubber as the dust abatement technique.

Table 15.4: Total dust emissions to air from a beet pulp dryer after treatment in a wet scrubber

Installation ID-point of release	Dust (mg/Nm ³)	O ₂ content (%)	Monitoring standard	Frequency of monitoring	Additional information
111-1	38.50	7.90	VDI 2066	Yearly	Central chimney Two high-temperature dryers/natural gas, lignite Wet gas Cyclone step before
329-1	64.24	16.30	EN 13284-1	Monthly	Rotary dryer/natural gas Cyclone step before
286-2	109.00	14.50	NF X 44 052	Monthly	Rotary dryer/natural gas Dry basis
288-1	144.00	13.90	NF X 44 052	Monthly	Rotary dryer/coal Dry basis
287-1	265.00	14.60	MO/E/504/002	Monthly	Rotary dryer/coal Dry basis

Source: [193, TWG 2015]

Reference literature

[193, TWG 2015]

15.4.4.1.3 Use of gaseous fuels**Description**

Switching from the combustion of a solid fuel (e.g. coal) to the combustion of a gaseous fuel (e.g. natural gas, biogas) that is a less harmful in terms of emissions (e.g. low sulphur content, low ash content or better ash quality).

Technical description

The choice of fossil fuels with a lower content of potential pollution-generating compounds can lead to a significant reduction in emissions to air. In cases where supply is available, choosing or changing to a gaseous fuel may be a viable option. This will normally involve the use of fuels with a low ash content or low sulphur content.

Achieved environmental benefits

Reduction of dust and SO_x emissions to air.

Environmental performance and operational data

The combustion of natural gas could be associated with dust emission levels lower than those associated with the combustion of coal or lignite, as shown in Table 15.3 and Table 15.4.

Cross-media effects

No information provided.

Technical considerations relevant to applicability

In general, the use of gaseous fuels with a lower content of ash, sulphur, nitrogen, carbon, mercury, etc. is an option to consider. The possibility to choose a fuel may be limited by the constraints associated with the availability of different types of gaseous fuels.

Economics

No information provided.

Driving force for implementation

To meet legal requirements from competent authorities.

Example plants

See Table 15.3 and Table 15.4.

Reference literature

[145, COM 2017], [193, TWG 2015]

15.4.4.1.4 Indirect (steam drying) of sugar beet pulp

Information on this technique is available in Section 15.4.1.2.

Environmental performance and operational data

Dust emission levels between 6.3 mg/Nm^3 and 44.3 mg/Nm^3 (normalised at 16 % O_2) were reported by installation #394-1, without abatement techniques reported and using the standard EN 13284-1 [193, TWG 2015].

Reference literature

[193, TWG 2015]

15.4.4.1.5 Low-temperature (pre)drying of sugar beet pulp

Information on this technique is available in Section 15.4.1.5.

Environmental performance and operational data

Dust emission levels between 1.9 mg/Nm^3 and 7.2 mg/Nm^3 (wet basis) were reported by installation #112-1, without abatement techniques implemented and using the standard EN 13284-1 [193, TWG 2015].

Dust emissions measurements in the belt dryer of installation #287 (this dryer was not part of the FDM data collection, measurements were provided afterwards for the years 2016 and 2017) showed values between 10 mg/Nm^3 and 20 mg/Nm^3 (at 21 % O_2 , wet basis) [301, CEFS 2018].

Reference literature

[193, TWG 2015], [301, CEFS 2018]

15.4.4.1.6 Solar drying of beet pulp

Information on this technique is available in Section 15.4.1.3.

15.4.4.2 Reduction of TVOC emissions from beet pulp dryers

15.4.4.2.1 Wet scrubber

The technique is generally described in Section 2.3.7.3.1.

Environmental performance and operational data

Table 15.5 shows installation-specific performance data related to the application of a wet scrubber as the TVOC abatement technique.

Table 15.5: Average values of periodic measurements of TVOC emissions to air from a beet pulp dryer after treatment in a wet scrubber (dry basis)

Installation ID-point of release	TVOC (mg/Nm ³)	O ₂ content (%)	Monitoring standard	Frequency of monitoring	Additional information
288-1	181.30	13.00	EN 12619	Monthly	Rotary dryer/coal
287-1	192.00	15.86	EN 12619	Yearly	Rotary dryer/coal Cyclone step before
286-2	235.00	15.80	EN 12619	Monthly	Rotary dryer/natural gas

Source: [193, TWG 2015]

Reference literature

[193, TWG 2015]

15.4.4.3 Techniques to reduce SO_x emissions from beet pulp dryers

15.4.4.3.1 Wet scrubber

The technique is generally described in Section 2.3.7.3.1.

Environmental performance and operational data

Table 15.6 and Table 15.7 show installation-specific performance data related to the application of a wet scrubber as the SO_x abatement technique.

Table 15.6: Average values of periodic measurements of SO_x emissions to air from a beet pulp dryer after treatment in a wet scrubber (dry basis)

Installation ID-point of release	SO _x (mg/Nm ³)	O ₂ content (%)	Monitoring standard	Frequency of monitoring	Additional information
287-1	200.00	14.30	NI	Yearly	Rotary dryer/coal
288-1	326.50	13.40	EN 14791	Monthly	

NB: NI = no information provided.
Source: [193, TWG 2015]

Table 15.7: Average values of continuous measurements of SO₂ emissions to air from a beet pulp dryer after treatment in a wet scrubber

Installation ID-point of release	SO ₂ (mg/Nm ³)			O ₂ content (%)	Additional information
	Yearly average	Max	95th percentile		
111-1	47.00	204.00	74.50	7.96 (yearly average)	High-temperature dryer/natural gas Wet gas

Source: [193, TWG 2015]

Reference literature

[193, TWG 2015]

15.4.4.3.2 Use of natural gas or fuels with a low sulphur content

The technique is generally described in Section 15.4.4.1.3.

Environmental performance and operational data

The combustion of natural gas is associated with SO_x emission levels lower than those associated with the combustion of coal or lignite, as shown in Table 15.8.

Table 15.8: Average values of periodic measurements of SO_x emissions to air from a beet pulp dryer

Installation ID-point of release	SO_x (mg/Nm³)	O₂ content (%)	Frequency of monitoring	Type of dryer	Type of fuel
412-3	0.09	16.5	Yearly	Rotary dryer	Natural gas
352-1	27.7	15.89	Yearly	Rotary dryer	Coal
414-2	24.2	14.2	Yearly	Rotary dryer	Coal
287-1	200	14.3	Yearly	Rotary dryer	Coal
242-1	295	12.2	Yearly	Rotary dryer	Fuel oil
413-1	325.3	7.5	Monthly	Rotary dryer	Coal
<i>Source: [193, TWG 2015]</i>					

Reference literature

[193, TWG 2015]

16 ADDITIONAL SECTORS (THUMBNAIL DESCRIPTIONS)

The descriptions have been restricted to a brief outline of the sector including products produced, processes applied, any significant emissions or consumption, and specific techniques for pollution prevention or control. Since the descriptions aim to give an initial overview of the processes, they do not necessarily describe all production routes. The descriptions are, therefore, a starting point in the determination of BAT and additional information may be needed, in accordance with Articles 14(5) and 14(6) of the IED.

16.1 Dry pasta

The basic raw material for the production of high-quality pasta products is semolina from durum wheat. A total of 1.04–1.05 tonnes of semolina are used to produce 1 tonne of pasta. Water and other ingredients are added to make a stiff dough containing approximately 31 % water. The dough is forced under pressure through dies of an extrusion auger. The major environmental issue in this sector is energy consumption as all pasta manufacturing processes involve drying.

16.1.1 Main processes and techniques

In modern pasta factories, the manufacturing process is continuous. Semolina is stored in silos. It is then sent by pneumatic conveyers to the production area. Semolina is sieved and then mixed with water to form dough. Semolina has a starting moisture content of 10–14 %. In the mixing operation, 22–30 kg of water are added per 100 kg of semolina. The moisture content during mixing varies between 30 % and 35 %, depending on the quality and the type of semolina, and the shape of the pasta being produced. The weight of the semolina and the flow of water being fed to the process are continuously monitored and automatically regulated using microcomputers. At this stage in the process, it is important for the semolina to be well hydrated and in a uniform way, to maintain an equal consistency in the dough. This ensures the quality of the final product, e.g. by preventing brittleness, surface defects and poor cooking quality.

The final mixing operation is degassing in a vacuum mixer, which removes the air that has been introduced during the earlier mixing operation. This prevents oxidation of the semolina pigments, or of the egg, in the case of egg pasta and gives a shiny appearance to the product. The pasta is pressed, extruded or laminated, depending on the shape of the final product. This is carried out using a worm screw within a cylinder which is cooled from outside. This physical action also causes the hydrated proteins to interact to form gluten. The dough is extruded at pressures varying between 4 MPa and 12 MPa through a bronze or steel die corresponding to the shape of the product. If the holes of the die are coated with Teflon, a smooth pasta is obtained; otherwise a pasta of rough appearance is produced. The pasta comes out of the die with a moisture content of about 30 %. The final moisture content should not exceed 12.5 %, to achieve the required specific consistency and enable a long shelf life. This and the cooking characteristics of the product are achieved by drying the pasta in three distinct stages, known as predrying, central drying and final drying.

Predrying comprises intensive ventilation to create a thin dry surface area which prevents the various pasta pieces from crushing or sticking to each other. Filtered air, devoid of dust and other impurities, is used. The temperature and humidity are both controlled to regulate the evaporation rate and prevent fragility, which happens if the pasta is dried too quickly. Formation of mould occurs if the process is too slow. Predrying takes 10 to 60 minutes and removes 15–20 % of the moisture present. This phase is not needed for long pasta since it is transported hanging from canes, and there is less danger of sticking and deformation.

Central drying is achieved by another hot airflow repeated after alternate phases of rest, known as tempering. Tempering allows the moisture remaining inside the pasta to be redistributed uniformly on the surface. In some pasta production lines, tempering is not needed. During central drying, up to 60 % of the moisture present is removed.

During final drying, the pasta is passed through several chambers, where it is subject to a powerful hot and dry airstream that removes up to 25–30 % of the initial moisture. This last phase is carried out at variable temperatures, which may exceed 80 °C. The temperature and the duration of the cycle vary according to the type of technology employed and the type of pasta required. Depending on the kind of production line, drying can be performed in separate chambers or in an uninterrupted tunnel, subdivided into three continuous stages.

The design of production lines varies depending on the shape of the pasta, e.g. lines for long pasta have spreaders to hold the strips straight and to keep them apart, and lasagne, nest and tangle pasta lines have special layouts, and lines producing short pasta have initial kneaders. At the end of the drying line, a cooling chamber lowers the temperature of the dried pasta before it is conveyed to storage silos. The pasta is then transferred for primary packaging, using sheets of plastic or cardboard boxes, before secondary packaging, palletisation and storage prior to dispatch. The dry pasta production process is summarised in Figure 16.1.

For egg pasta, the production process is the same as that for other dry pastas, except for the presence of an automatic measurer for the egg mixture [82, Unione Industriali Pastai Italiani 2002].

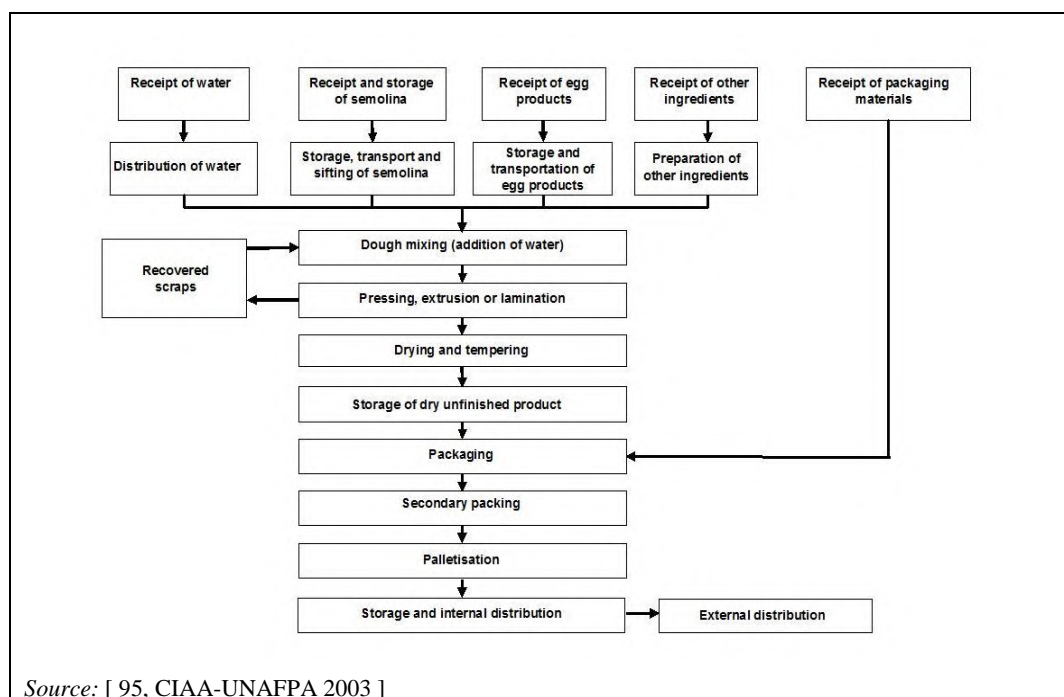

Figure 16.1: Summary of the dry pasta production process

16.1.2 Energy consumption

The drying step utilises about 85–90 % of the thermal energy and 50–60 % of the electricity consumption of the installation. These figures may even be higher for lines producing special products such as nests or lasagne. Air conditioning of the workspace needs 35–50 kWh/t of products.

Evaluating energy consumption in the sector, the results of a study on pasta installations (covered by Directive 2010/75/EU) with a production capacity of over 75 300 t/d led to the consumption of thermal energy being estimated at 417–527 kWh/t and the consumption of electric energy at 78–115 kWh/t (short cut line), 86–138 kWh/t (long cut line) and 63–321 kWh/t (special cut line) [98, TWG 2017].

Thermal energy is usually obtained in natural gas superheated water boilers or diathermic oil boilers. In a typical pasta installation (i.e. covered by Directive 2010/75/EU) boiler room, at least two boilers are installed, in order to guarantee production even with one of the boilers out of order.

A typical pasta installation (> 300 t/day finished product) needs at least 6 MW thermal power to be installed. The biggest pasta installations have boiler rooms up to 20 MW. Typical single boiler sizes used are from 2 MW up to 5 MW. In many pasta installations combined heat and power (CHP) generation plants are installed, with a thermal input from 5 MW to 20 MW. Superheated water, of 130–160 °C and 4–7 bar (as measured in a hydraulic air vessel), is used to supply thermal energy from the boiler room to the pasta dryer, where heat exchangers warm the air inside at 65–75 °C [98, TWG 2017].

16.1.3 Water consumption

Water consumption is between 0.8 m³ and 2.1 m³ tonne of product. Water is mainly used as an ingredient. The production of process-related polluted waste water is reported to be insignificant [64, CIAA-UNAFPA 2002], [98, TWG 2017].

16.2 Bakery goods

One of the main bakery products is bread. Bread includes several bakery products and the types vary significantly from country to country.

16.2.1 Main processes and techniques

Bread is made by combining flour, water, salt and yeast. Wheat is the most important cereal grain produced and traded in the world for the production of bread and other baked products. Commercial production of bread may also involve the addition of preservatives and additives to improve flavour and texture and prevent microbiological growth. Production of most baked products containing wheat flour begins by mixing the ingredients to form a dough. Incorporation of air during dough mixing is necessary to achieve a baked loaf of good volume, structure and texture. As dough becomes cohesive, it starts to incorporate air and, thus, decreases in density.

After bulk fermentation, the dough is divided into individual loaf-sized pieces, and then given time to allow the dough to relax before moulding. The moulding operation is essentially sheeting followed by curling, rolling and application of pressure. As the dough is sheeted, i.e. passed between rolls to be flattened during the various processes, it is sheeted in different directions. Continued machining in one direction would align the protein fibrils and result in a dough that was strong in one direction but weak in the direction of a 90 ° angle to the sheeting. After being moulded, the loaf is ready for proofing. This is usually accomplished at 30–35 °C and at 85 % relative humidity. Because the dough now has only limited viscous-flow properties, it fills the pan by expansion. Proofing usually takes about 55 to 65 minutes; the dough increases greatly in volume. After proofing, the dough is ready for baking.

Ovens are heated using either electrical energy or fuel in the form of natural gas or oil. For infrared ovens, special types of burners are applied. In bakery lines, the thermal energy used for baking is highly variable depending on the single oven technology (direct, indirect and cyclothermic) and baking cycle chosen for technological reasons. The monthly measured thermic values can range between 0.110 kWh/kg and 2 kWh/kg, as observed in a two-year study on 51 different ovens. The electric energy usage for baking normally ranges from 0.125 kWh to 0.167 kWh per kg of product (450 – 600 kJ/kg) [98, TWG 2017].

In a baking oven, the moisture at the surface is evaporated and removed by the hot air. When the rate of moisture loss at the surface exceeds the rate of transport of moisture from the interior of the product to the surface, the surface dries out and a crust is formed. There are four types of ovens; direct heating, indirect heating, electric and infrared ovens. All oven types can be batch or continuous in operation. In batch ovens, the walls and the base are heated. In continuous ovens, radiators are located above, alongside and below the conveyor belt. Batch ovens incur higher labour costs than continuous ovens. Another disadvantage can be the non-uniformity in baking times, caused by delays in loading and unloading the oven.

In direct heating ovens, air and combustion gases are recirculated by natural convection or by fans around the product to be baked. The temperature in the oven is controlled by adjusting the air and fuel flow rates to the burner. The fuels normally used are natural gas, propane and butane. The gas is burned in ribbon burners above or sometimes below the conveyor belt and product. The advantages of direct heating ovens are their short baking times, high thermal efficiencies, rapid start-up and good temperature control. Good management and care are necessary to prevent contamination of the food by undesirable products of combustion.

In indirect heating ovens, the air in the baking chamber is heated via a heat exchanger, by steam or by burning a fuel. The air in the baking chamber is typically recirculated through the baking chamber and the heat exchanger. Other methods include passing the combustion gases through radiator tubes in the baking chamber, or burning the fuel between a double wall whilst

exhausting the combustion gases from the top of the oven. Electric ovens are heated by induction, heating radiator plates or bars.

Typical methods for making bread are the straight dough, sponge dough, sourdough, and Chorleywood processes.

In the straight dough process, the dough is allowed to ferment for 2 to 3 hours. After fermentation, the dough is divided into loaf-sized pieces, rounded into a ball, given an intermediate proofing time of 10 to 20 minutes, and then moulded and panned.

In the sponge dough process, a sponge is prepared from approximately 65 % flour, water and yeast. The sponge is only mixed enough to have a uniform mixture and then allowed to ferment for 3 to 4 hours. After fermentation, the sponge is returned to the mixer and mixed with the rest of the formula ingredients. At this stage, the dough is mixed to optimum development. After mixing, the dough is allowed to relax for 15 to 20 minutes.

Utilisation of the sourdough process is the traditional leavening method in bread making. Bread doughs containing higher proportions of flour or meal require more acidification than is generally achieved by a sourdough process. During sourdough fermentation, a typical microflora develops that includes lactic acid bacteria, *lactobacilli*, and yeasts. Various sourdough processes, such as multi-, two- and single-stage, varying from 2 hours up to 24 hours, were designed to increase the growth of yeast and lactic acid bacteria to give the final sourdough proper acidity, especially the lactic acid/acetic acid ratio, and achieve the desired dough consistency. Often baker's yeast, *Saccharomyces cerevisiae*, is added to accelerate the leavening process. Consequently, the proofing time of sourdough bread is often long, in the order of several hours. For the production of rye bread, acidification is required.

In the UK, the majority of commercial bakers employ the Chorleywood process. In this process, dough mixing and development take place in a single operation in the presence of an oxidising agent such as potassium iodate, potassium bromate, or ascorbic acid. This process requires a high-quality wheat flour with a protein content of 12.5 % dry matter together with a high level of starch damage and hence high water absorption. An oxidising improver, fat or emulsifier, and extra water and yeast are mixed in at this stage. The whole mixing and development process lasts between 2 and 5 minutes. All short-time systems require high levels of oxidants. The dough ingredients are mixed together with an intensive energy input and transferred to a hopper which is sometimes sprayed with oil. The dough is divided into loaf-sized pieces. A preliminary rounding is given to the dough at this stage. The dough is then allowed to rest (first proof) before being given a final moulding and normally placed into tins. The tins may be sprayed with oil before filling. The dough is allowed to ferment a second time (second proof) and may be cut before baking.

For additional information consult the Sectoral Reference Document on Best Environmental Management Practices for the food and beverage manufacturing sector [107, COM 2017].

16.3 Coffee manufacturing

Commercial coffees are grown in tropical and subtropical climates at altitudes of up to around 1 800 metres. Coffees from different producing regions possess different characteristic flavours. Roasting coffee beans and the production of instant coffee are energy-intensive processes.

For additional information consult the Sectoral Reference Document on Best Environmental Management Practices for the food and beverage manufacturing sector [107, COM 2017].

16.3.1 Main processes and techniques

The main processing steps in the manufacture of roasted and instant coffee are the following [117, European Coffee Federation 2016]:

- sorting and removal of foreign matter;
- mixing/blending;
- decaffeination;
- roasting;
- grinding;
- for instant coffee manufacturing: extraction using water;
- for instant coffee manufacturing: concentration by evaporation;
- for instant coffee manufacturing: drying/freeze-drying;
- for decaffeinated coffee manufacturing: decaffeination;
- packing and filling (including gas-flushing and/or packing under vacuum).

Roasted coffee

Roasting is a time-temperature-dependent process whereby chemical and physical changes are induced in green coffee beans, in particular:

- the volume increases up to 80 %;
- the specific weight decreases by 15–20 % due to the release of water and volatile substances;
- the colour changes from light green to dark brown;
- the surface becomes shiny due to the run-off of organic oils and the structure becomes more porous due to the development of CO₂.

These modifications occur in different steps of the roasting process while the temperature of coffee increases, as described in Table 16.1.

Table 16.1: Why and how coffee beans change during the roasting process

Modification	Description
Drying of the beans	At a temperature of 50–55 °C, the proteins in the coffee beans denature and the water evaporates.
Development of the brown colour	Starting from 100 °C, the browning phenomenon occurs due to pyrolysis (degradation of organic compounds) and water continues to evaporate, leading to the swelling of the beans.
Decomposition	At 140 °C, the decomposition of organic compounds due to the reaction between sugars and proteins starts at the bean surface (also known as Maillard reactions), causing the development of hundreds of total volatile organic compounds. By increasing the temperature up to 200 °C, the decomposition continues, affecting the inner part of the beans. The humidity is decreased by up to 1–3 %.
Full roasting	From 200 °C, the oils are released and the surface of the beans becomes shiny with the typical red-brownish colour. Roasting ends at 200–250 °C according to the characteristics of the desired final product.
<i>Source:</i> [200, Italy 2016]	

Raw coffee can be roasted in a batch or continuous operation. Discontinuous methods involve the use of batch roasting machines, which process a fixed amount of coffee in a defined time cycle (the roasting cycle), while the continuous methods involve the use of a continuous roaster where the coffee is continuously fed at the entry point of the machine, roasted and discharged at the output point. No waste water is produced during roasting.

In a batch roaster, the coffee is fluidised and heated to roasting temperature with hot air entering tangentially. The roasting process is stopped by feeding water into the roasting chamber. The coffee is then emptied into the cooler. The coffee skin that is flaked off during the roasting process is kept from the roasting cyclone. The air is recirculated through a heating oven. The excess air is treated before being emitted to the environment. The roasting time can vary considerably. For the sector as a whole, the roasting cycle typically ranges from 3 to 15 minutes. The refilling of the roasting chamber with raw coffee only takes place after the completion of the roasting, or alternatively after the emptying of the roasting chamber.

Batch roasters have a wide roasting range which facilitates the processing of the most varied types of raw coffee, with the most varied roasting results. For example, in an installation in Germany, a roaster with a capacity of up to 4 000 kg/h is used. This roaster is particularly suitable for roasteries with a large variety of products, high quality expectations and high production outputs. The layout of the batch roaster used in Germany is illustrated in Figure 16.2.

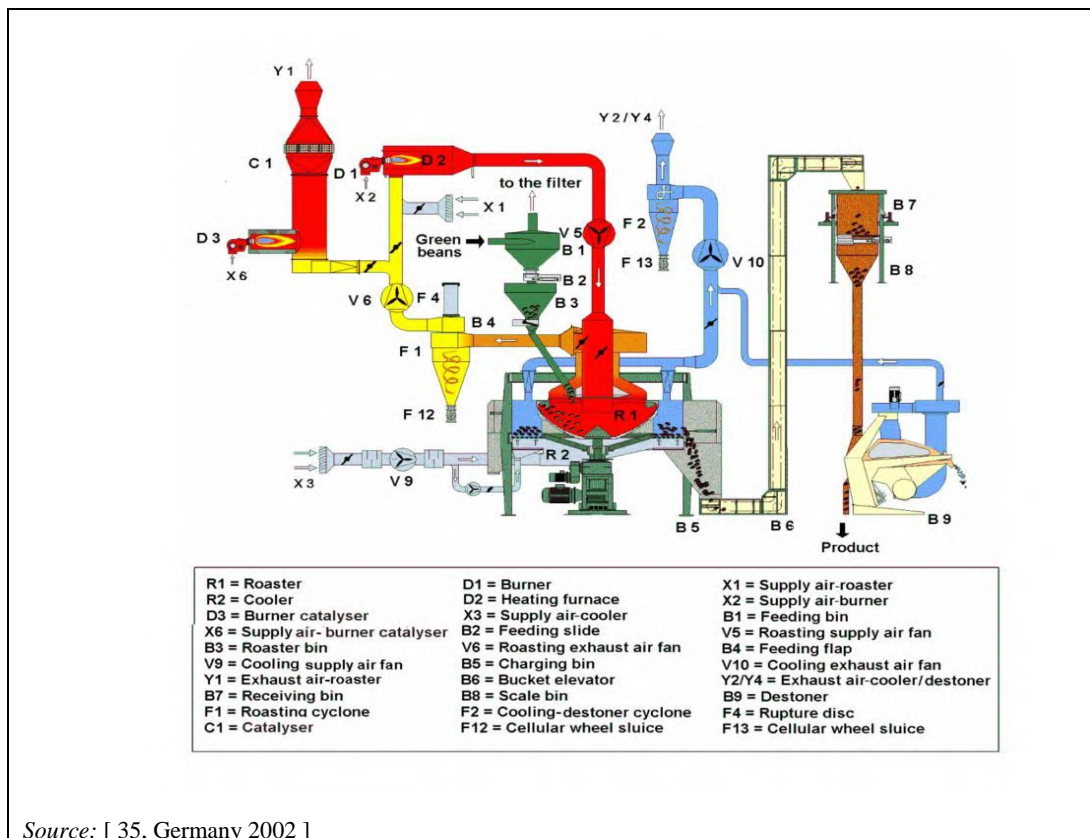

Source: [35, Germany 2002]

Figure 16.2: Batch roaster used by a German coffee company

In a continuous roaster, raw coffee is supplied without interruption, and roasting and cooling take place when passing through the roaster. The coffee passes in small doses through a roasting drum containing small batch compartments. The coffee is mixed by the movement of the drum and the injection of hot air. Since the roasting takes place in mini batches, no replacement of product is possible without interrupting the roasting process. Dust and skins are removed using a cyclone. Continuous roasters where only a few types of coffee are roasted and the roasting takes place in a multiple-shift operation are particularly advantageous.

The layout of a continuous coffee roaster used in Germany is illustrated in Figure 16.3.

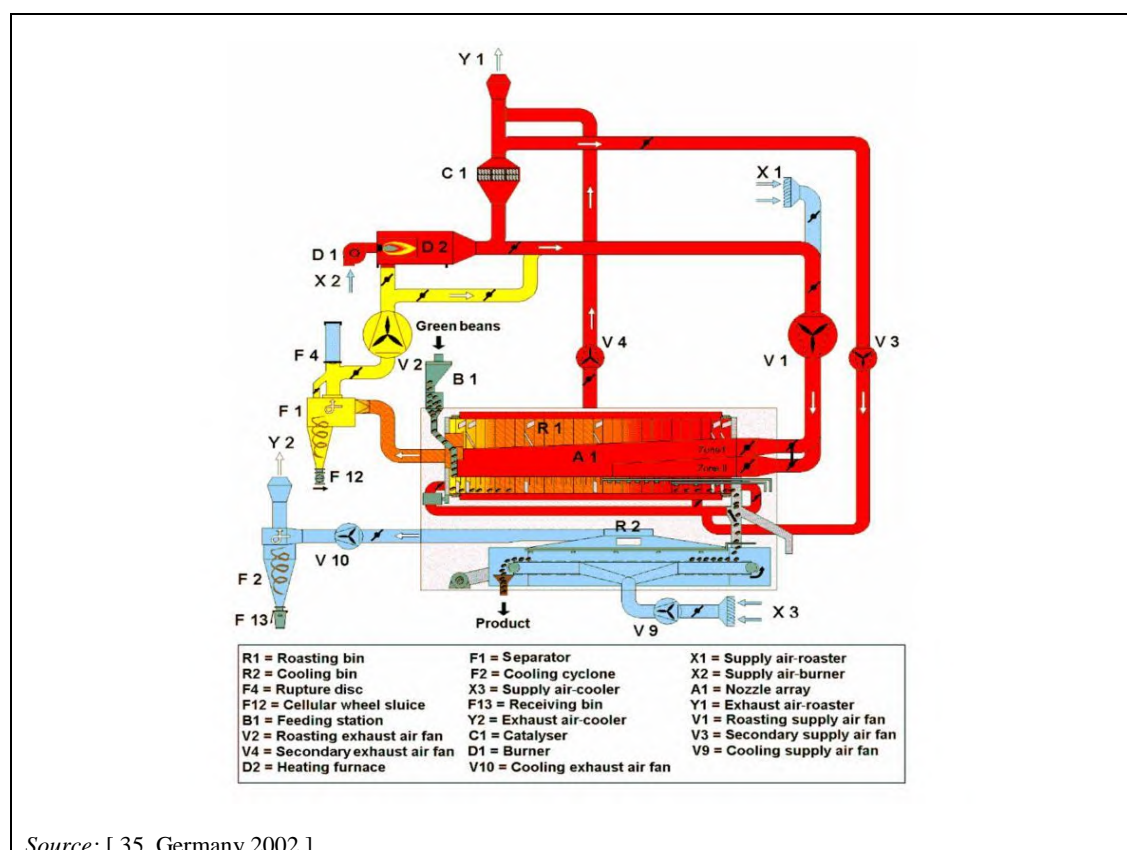

Figure 16.3: Continuous coffee roasting process used by a German company

The outlet of both the roaster and the cooler contain odour components, CO_2 , NO_2 and VOC. The concentration of VOC causing this odour is higher at the roaster outlet than at the cooler outlet. TVOC emission levels are higher when the product is roasted to a higher degree, e.g. when the product temperature at the end of the roasting process is higher. The difference in emissions between a low roasted and a very high, i.e. very dark, roasted product can be as much as a factor 10. For batch roasters, the highest concentrations are emitted just before the end of the roasting process. In continuous roasters, the emissions are also continuous. The absolute emission TVOC level depends on the product temperature at the end of the roasting; the amount of air used for roasting, which has a diluting effect; the product itself; and the roasting time. The emissions of organic substances and the organic roasting losses result from the decomposition or chemical reaction of, for example, chlorogenic acid, citric acid, oxalic acid, crude proteins and trigonellin. Nitrogen-based compounds, for example amines and sulphur-based compounds, e.g. mercaptans, contribute considerably to the odours emitted by coffee-roasting installations. In the raw gas, odorant contents of up to $300\,000\text{ OU}_E/\text{Nm}^3$ have been measured. VOC mass concentrations of up to $10\,000\text{ mg}/\text{Nm}^3$ are produced. Ammonia, nitrogen oxides, carbon dioxide and carbon monoxide are also produced. Dust emissions may also be a problem.

Instant coffee

Instant coffee is subjected to similar processing, namely blending, roasting and grinding, although processing details such as particle size after grinding may differ. During extraction of coffee for the production of soluble coffee, water is the extracting solvent. The coarsely ground coffee is extracted in a battery of batch percolating columns. The process is operated semi-continuously with water in a countercurrent flow to the coffee, from the most processed column to the one just filled with fresh roast and ground coffee.

Decaffeinated coffee

Green beans are moisturised by steam or water to a moisture content of around 20 %. Solvents are then used to extract the caffeine from the wet beans. Decaffeination of coffee is carried out by extraction with decaffeinating agents, such as water or another solvent such as methylene chloride, coffee oils, ethyl acetate or supercritical CO₂. Extraction yields of 97 % of the caffeine can be obtained. Steaming or stripping is used to remove solvent from the beans. Two main extraction methods for decaffeination can be distinguished, i.e. the direct and indirect methods. The beans are then redried to their original moisture content prior to roasting. Solvent extraction of the caffeine, from the extract used to make instant coffee rather than from the bean itself, may also be applied.

The direct method is called solvent decaffeination. In this method, solvents, such as methylene chloride, coffee oils, ethyl acetate or supercritical CO₂, are used. The main process parameters are temperature and time. These vary depending on the type of coffee and on the type of solvent. For example, when coffee oil is used as the decaffeinating agent the process may take 6 to 9 hours at 95–105 °C, whereas supercritical CO₂ is used under high pressure at 40–80 °C for 5 to 30 hours. Table 16.2 summarises the process.

Table 16.2: Solvent decaffeination process

	Action	Effect
1	Green beans are first soaked with water and steam	Beans swell by 30–40 %
2	A decaffeinating agent is added to the wet beans	The agent solubilises the caffeine from the beans
3	The agent is drained or steamed away	The agent, together with 97 % of caffeine, are removed from the beans
4	The beans are dried by hot air or vacuum drying	The beans are dried and are now ready for roasting
<i>Source: [192, COM 2006]</i>		

The indirect method is called water decaffeination. In this method, water is used as the extraction solvent. The process is described in Table 16.3.

Table 16.3: Water decaffeination process

	Action	Effect
1	Green beans are first soaked with water and steam	The water extracts the caffeine, but also some soluble coffee solids
2	The beans are separated from the aqueous solution	The water extract containing caffeine and coffee solids is separated
3	Water extract is passed over an activated charcoal bed. A solvent, e.g. methylene chloride, may be used instead of activated carbon	The caffeine is removed from the solution by activated carbon filtration or methylene chloride. The coffee solids remain in the aqueous solution
4	The decaffeinated extract is concentrated and added back to the predried decaffeinated beans	Beans and coffee solids, now without the caffeine, are ready for roasting
<i>Source: [192, COM 2006]</i>		

Freeze-drying

If the incoming product is a liquid, e.g. coffee extract, it is frozen in two steps, at two freezing temperatures and times, and then it is ground. For more information, see Section 7.2.1.

16.3.2 Water consumption

The water consumption for the abrupt interruption of the roasting process amounts to 10–15 % of the weight of the raw coffee.

16.3.3 Solid output

The coffee skins produced during the roasting process, which can be up to 2 % depending on the type of coffee, are used as incineration fuel or composted.

In instant coffee production, during the extraction of soluble solid matter from the roasted coffee, a large quantity of coffee grounds is produced in addition to the fluid coffee extract. These are utilised as fuel in special grate firing installations. The ground coffee is used, in balance with heating oil and natural gas, as a special fuel.

16.3.4 Emissions to air

Air environmental issues of coffee manufacturing are related to the release of various types of air pollutants (e.g. NO_x, VOC, CO, dust) from roasting. The quantity of pollutants contained in the exhaust gas depends on the roasting cycle implemented, the blend of coffee beans selected and on the efficiency of the abatement. More specifically [80, Germany 2015], [200, Italy 2016]:

- NO_x concentrations from the roasting process are extremely variable and random, making it difficult to definitively predict the concentrations in function of coffee origins, blends, process temperature, desired roasting grade, and pollution abatement equipment installed, etc.;
- generally, NO_x emissions from decaffeinated coffee roasting are lower those from regular coffee roasting;
- nitrogen compounds (e.g. amines) and sulphur compounds (e.g. mercaptans) are of considerable significance in terms of the odour emitted by coffee-roasting plants;
- organic emissions arise due to the fact that substances such as chlorogenic acid, citric acid, oxalic acid, crude proteins, etc. are broken down or converted by chemical reaction, thus releasing volatile substances;
- along the manufacturing process, coffee beans are moved by mechanical or pneumatic transport; these operations involve dust emissions;
- dust generated by green coffee handling needs to be treated, while dust generated by roasted coffee beans handling can only be abated via a hopper.

Thermal and catalytic oxidation, biofilters and bioscrubbers are examples of end-of-pipe techniques used for reducing TVOC emissions to air. Biofilters and bioscrubbers have proven to be unsuitable for the treatment of waste gases from roasting [17, TWG 2018]. Thermal oxidation takes place at temperatures in excess of about 800 °C, and catalytic oxidation from about 350 °C, depending on the type of catalyst [80, Germany 2015].

To ensure a TVOC emission level lower than 50 mg/Nm³ and to contain odour impact, for batch roasting or highly intermittent processes, the use of catalytic systems is a best available technique, although it gives rise to NO_x formation in high concentrations. Oxidative catalysers contribute to generating NO_x by oxidising the nitrogen compounds developed during roasting process, starting from molecules naturally present in coffee (mainly pyridine, pyrazine and caffeine). Emissions of NO_x, which is negligible in all the steps of the roasting cycle until the catalytic converter, are dramatically increased by the converter itself, whereas the CO concentration is effectively reduced [200, Italy 2016].

For continuous roasting processes, catalytic afterburning is an alternative to thermal (regenerative or recuperative) oxidation [17, TWG 2018].

Figure 16.4 shows data related to CO and NO₂ emissions from an Italian installation.

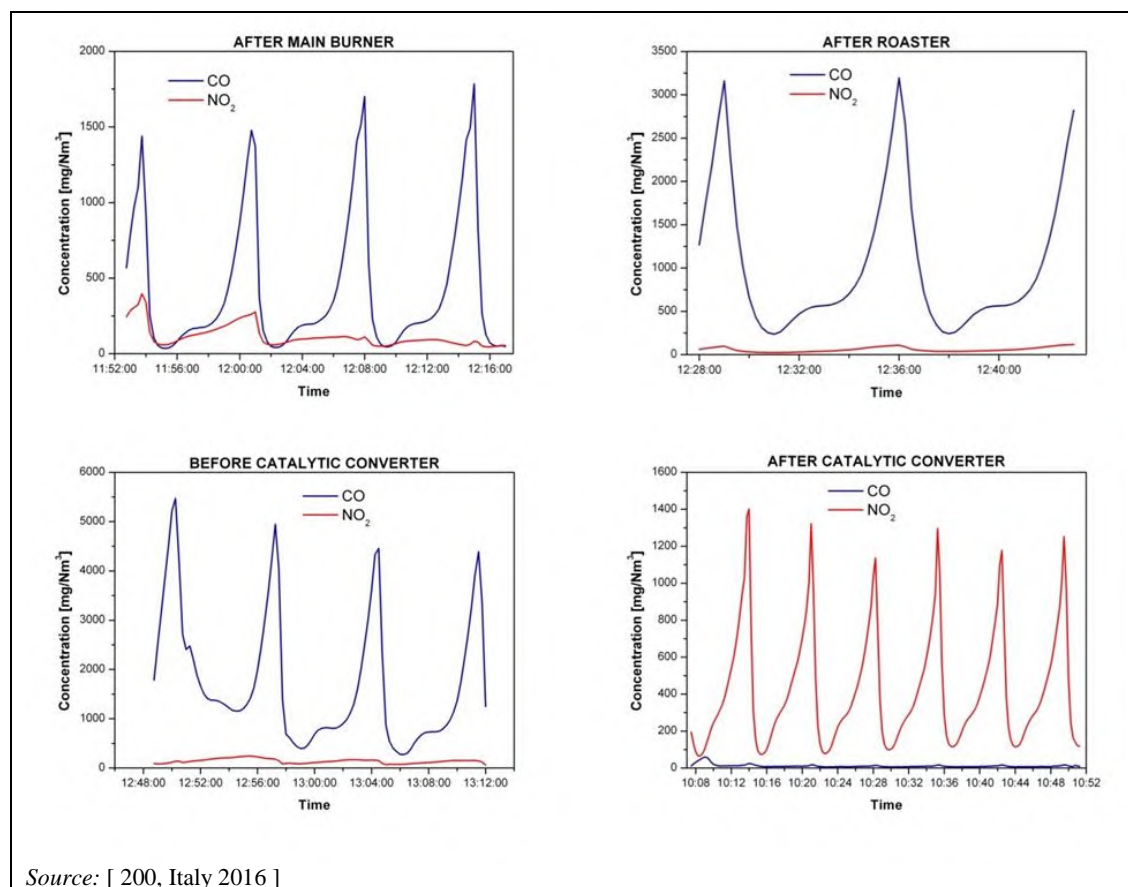

Figure 16.4: CO and NO₂ emissions at different measured points in an Italian coffee installation

In order to understand how NO_x is generated, it is necessary to compare the results of analysis carried out at different points of a roaster. Values in Figure 16.4 show that the catalytic oxidation contributes to the generation of NO_x by oxidising the nitrogen compounds developed during roasting, starting from molecules naturally present in coffee.

Values shown in Figure 16.4 (referring to a batch coffee roaster) are average levels, not maximum detected levels or maximum levels in a roasting cycle. Many factors can influence the NO_x concentration, in particular air flow and quantity and type (regular vs decaffeinated) of coffee processed.

The following issues should be taken into account in relation to the measurement of NO_x emissions from coffee roasting [115, European Coffee Federation 2016]:

- The cyclic nature of the roasting process. This means that gas emissions change rapidly in volume and over time.
- The effects of water vapour in the sampling and measuring system. This is particularly relevant in industrial roasters including water quenching at the end of the roasting cycle. Unless specifically designed for the instantaneous moisture loads (and standard portable systems are not), then the effects of water vapour are unknown.

- Sampling system issues: at the high temperatures of many roaster exhausts, the gases can react with the sample pipe material. Unreactive materials are not supplied as standard with portable systems for example.
- Interference of other gases with NO_x measurement. The mix of other gases in coffee roaster exhausts is much more complex than other stationary systems such as steam boilers and internal combustion engines.

16.4 Distilled beverages

The main raw materials used for the production of distilled beverages include agricultural raw materials (cereals, grape, fruits, sugar cane, potatoes, etc.), water and yeast.

The information sources for this sector are [35, Germany 2002] and [196, spiritsEUROPE 2015].

16.4.1 Main processes and techniques

Processing of raw material

Raw cereals may initially be milled, cooked, mashed or slurried for the purposes of deriving solubilised sugars. This process may involve the use of natural or additional enzymes.

Fermentation of sugars or starch

Soluble sugars are converted (ethanol yield observed 90–95 % theoretical) through the reaction of various product-specific yeast strains to form alcohol. It proceeds according to Gay Lussac's Equation:



Distillation

Distillation is the process of concentrating alcohol by boiling and condensing the resulting vapours. The condensing process can achieve differing flavour profiles and can also be product-specific. There are three main types of distillation apparatus used for the production of spirit drinks:

- pot stills;
- pot stills with additional column(s);
- column – allowing possible continuous distillation.

Flavouring/Colouring

Some spirit drinks may include the addition of permitted flavourings and colourants.

Mixing or blending

Spirits may be mixed, meaning combining two or more different drinks to make a new product. Spirits may also be blended, meaning combining two or more spirits of the same category, distinguished only by minor differences in composition due to one or more of the following factors: (a) the method of preparation; (b) the stills employed; (c) the period of maturation or ageing; (d) the geographical area of production. The spirit so produced is of the same category of spirit as the original spirits before blending.

Ageing/Maturation

Spirits may be matured/aged which means allowing certain reactions to develop naturally in appropriate containers, thereby giving the spirit in question organoleptic qualities previously absent.

Addition of water

Spirits may have water added before and/or after the maturation phase, frequently in the form of potable demineralised water produced using a small-scale treatment plant.

16.4.2 Energy consumption

The production of spirit drinks consumes energy for steam generation, production equipment, cooking, mashing, distillation, pumping/conveying materials, cooling/ventilation, ancillary operations and lighting.

Energy may be produced on site utilising a gas turbine, boiler plant or by including more novel renewable technologies such as anaerobic digestion, CHP or biomass generation. Within such facilities it is common practice to use energy-efficient heat exchangers and recovery circuits to utilise otherwise wasted heat. Larger rotating machinery may feature energy-saving measures such as variable speed drives to improve energy use.

16.4.3 Water consumption

A large proportion of spirits production has a once-through cooling water system. Other water uses include production water used to make the distilled spirits and process water for cleaning of the plant and equipment and other ancillary uses. The flavour profile of the product being manufactured may dictate the production water source based on the quality/flavour profile, etc.

16.4.4 Residues

Minimal quantities of waste are derived from the distilling process. Normal engineering maintenance waste and other common food manufacturing wastes will be derived. A variety of by-products can be produced including:

- spent raw materials left after the mashing process to remove all the fermentable sugars; this is a valuable by-product and has traditionally been sold off as animal feed;
- liquid residues arising from still distillation that may be used directly as a nutritional benefit to land or processed further for use within animal feed; solid materials may be processed and/or blended with liquids to produce animal feed.

Bioenergy facilities, such as biomass and AD plants, can convert mashing/distillation residues into renewable energy. Carbon dioxide produced during fermentation may be captured and processed within some facilities for use within the food and drink manufacturing sector.

16.4.5 Emissions to water

Effluent produced may contain COD/BOD, variable suspended solids loading, variable pH and trace metal elements and have a variable pH.

It has been reported that in a molasses distillery, a two-stage (see Section 2.3.6.2.3.2) waste water treatment system, anaerobic following aerobic, is used. The main treatment is an EGSB reactor (see Section 2.3.6.2.2.7) in which the organic load is largely degraded to methane gas, which may be used on site and only small quantities of sludge are produced. The COD and nitrogen loads are then reduced further in an activated sludge reactor (see Section 2.3.6.2.1.1).

16.4.6 Emissions to air

Emissions to air include:

- dust arising during materials handling (minimal);
- carbon dioxide arising from fermentation processes;
- NMVOC releases arising during distillation;
- ethanol releases during the maturation process;
- emissions associated with the combustion plant;
- emissions associated with the residue handling plant.

CO₂ emissions from the fermentation process can generally be regarded as carbon-neutral owing to the sequestering which took place during the cereal growth. Releases from distillation are minimal and controlled using condensing technology. Dust releases are minimal and controlled using existing cyclone/dust filtration technology.

Ethanol releases during the aging process are approximately 2 % per year. This process is essential to the overall flavour profile of the final product. Factors such as the cask type, and the nature and location of the ageing site all impact on the degree of release.

There are minimal odours associated with these production processes, including the animal feed plant which may be co-located at the same facility. Various abatement techniques have been successfully applied to larger facilities including wet scrubbing, cold plasma treatment and thermal oxidation.

16.5 Wine production

This section includes red and white wine manufacturing [71, AWARENET 2002], [195, CEEV 2015]. Fresh grapes are the raw materials used for the production of wine.

16.5.1 Main processes and techniques

Reception

When grapes are received at the winery, they are sorted by variety, quality and quantity. Containers are emptied directly into either crushing or transport equipment. Emptied containers are cleaned. The cleaning water is drained.

Grape crushing and destemming

Grape crushing or mashing takes place in grape mills. If maceration is intended, the mash can be stored in mash containers. To prevent the mash from oxidising, H_2SO_3 is added. The decision as to whether destemming of the white grapes is necessary before the grape mash is made depends on the variety and ripeness of the grapes as well as on the further processing of the mash.

Pressing

For white wine, the mash is transported to the wine press. The resulting unfermented grape juice is referred to as must. Sulphur dioxide is often added at this stage at the rate of 100–150 mg/l to suppress undesirable microorganisms, e.g. grape skins are often covered with bacteria and moulds, as well as the yeasts used in the process. The solid residues, e.g. pomace and marc, are then separated.

For red wine, when the fermentation process is finished, i.e. when the sugar levels are under 0.1 %, the wine is taken from the bottom of the tank and the marcs are transferred to the wine press to extract the remaining wine.

Fining

The fining agents used in winemaking are gelatine, casein, isinglass, chitin, albumin or egg white; natural mineral adsorbents, e.g. bentonite, diatomaceous earth or silica; and synthetic polymers, e.g. PVPP. It is reported that sediments from clarification are separated by centrifugation or filtration. This removes unwanted particles left in suspension.

Fermentation

Alcoholic fermentation takes place in large stainless steel fermentation reactors or vats with or without the addition of pre-cultivated yeast, e.g. usually *Saccharomyces cerevisiae*, and under rigorous temperature control. White wine is fermented after marc separation, while red wine is fermented together with grape marcs. Red wine, and sometimes white wine as well, goes through a second malolactic fermentation. This is a bacterial fermentation that converts the malic acid into lactic acid.

Ageing

After fermentation, wine is cooled to 4–5 °C and transferred to barrels or wooden vats made of oak for ageing. This allows the wine to stabilise and to develop softer tannins and complex flavours. Lees are separated from the wine every 3 to 4 months. The barrels are then washed and refilled.

Cold stabilisation

Cold stabilisation involves rapid cooling of the wine to near freezing temperatures to precipitate tartrate crystals which are undesirable in the bottled wine, whether present in the cork or in the bottom of the bottle. Tartrate precipitates in the tanks and is removed with an alkaline cleaning solution of 10 % caustic soda.

Bottling

Before bottling, wine is passed through a filtration system to remove remaining solid and insoluble turbid compounds. Bottling involves the microbial stabilisation of the wine and preserves the wine from important changes in taste and chemical composition.

For additional information consult the Sectoral Reference Document on Best Environmental Management Practices for the food and beverage manufacturing sector [107, COM 2017].

16.5.2 Energy consumption

The production of wine consumes energy for the following processes: crushing, pumping/conveying materials, cooling/ventilation, and ancillary operations.

16.5.3 Water consumption

Cleaning water and, in a smaller proportion, cooling water in fermentation tanks constitute the main water uses in wineries.

16.5.4 Emissions to water

Effluent produced may contain TOC/COD, BOD, variable suspended solids loading and have a variable pH.

After primary treatment, the waste water may be sent to the MWWTP if acceptable, or further treated on site. During secondary treatment, the yeast can provoke severe problems; the activated sludge can die and be washed out. Therefore, the separation of yeast and other solids is a necessary primary treatment step.

Anaerobic processes (see Section 2.3.6.2.2) and particularly anaerobic lagoons (see Section 2.3.6.2.2.1) and anaerobic filters (see Section 2.3.6.2.2.4) are reported to be the most suitable treatments for winery waste water. Alternatively, aerobic processes (see Section 2.3.6.2.1) can be used, e.g. aerated storage for three months is used at small wineries with low waste water volumes. Activated sludge (see Section 2.3.6.2.1.1) or trickling filters (see Section 2.3.6.2.1.5) are used. Activated sludge systems tend to be over-dimensioned, due to the seasonal variations, and are therefore expensive to install and operate. Trickling filters are reported to be 70 % effective and therefore further polishing is required.

Tertiary treatment (see Sections 2.3.6.3, 2.3.6.4 and 2.3.6.5) is used as a polishing stage for removal of remaining pollutants. The use of landspreading and evaporation lagoons has been reported in vineyards.

16.5.5 Emissions to air

Emissions to air include:

- dust arising during materials handling (minimal);
- biogenic carbon dioxide arising from fermentation processes;
- emissions associated with the residue handling plant.

There are minimal odours associated with these production processes.

16.5.6 Residues

Minimal quantities of waste are generated in wineries. Normal engineering maintenance waste and other common food manufacturing wastes will be derived.

The main by-products produced are grape marc and lees. Traditionally, these two by-products have been sold off to distilleries. An alternative is the use of grape marc in bioenergy facilities. The viability of such a treatment plant depends on the throughput, amongst other factors.

16.5.7 Natural tartaric acid production

Natural tartaric acid is an organic acid contained in some fruits but in a huge quantity only in grapes. It looks like white crystals or a white powder, is almost odourless and has a strong acid taste.

The L-(+)-tartaric acid isomer of tartaric acid is industrially produced in large amounts.

16.5.7.1 Main processes and techniques

Natural tartaric acid is mainly obtained by marc and wine lees, solid by-products of wine production. The process begins after the winemaking process, when wine marc and lees are obtained.

These by-products mostly consist of potassium bitartrate ($\text{KHC}_4\text{H}_4\text{O}_6$). In the past, this potassium salt was converted to calcium tartrate ($\text{CaC}_4\text{H}_4\text{O}_6 \cdot 4\text{H}_2\text{O}$) upon treatment with milk of lime ($\text{Ca}(\text{OH})_2$). Nowadays, higher yields of calcium tartrate are obtained by addition of calcium chloride or calcium carbonate. Calcium tartrate is then converted into tartaric acid by treating the salt with aqueous sulphuric acid.

To produce natural tartaric acid, only water, sulphuric acid and calcium tartrate are used. Sulphuric acid breaks the crystal of the calcium tartrate in tartaric acid and calcium sulphate. This solution is filtered to separate the liquid part containing the tartaric acid and the solid part containing calcium sulphate.

This solution is concentrated by evaporation in order to obtain a very thick crystal suspension. It is cooled at a specific temperature and centrifuged to remove the impurities. Then, tartaric acid is dissolved in water in order to be decoloured by active carbon (filter agents can be used to help the filtration phase).

The tartaric acid solution is filtered to eliminate the solid parts (active carbon and filter agent) while the liquid part is sent to a cationic resin which eliminates other impurities. This solution passes to a second concentration by evaporation to obtain a high density in the tartaric acid. This is then cooled. Once the established temperature has been reached, the crystal is washed with water using a crystalliser.

The natural tartaric acid is ready to be dried by hot air which eliminates the moisture. The finished product is sent to a particle size distribution plant which separates and mills it into all the commercial grain sizes. Now the tartaric acid is ready to be packed in 25 kg bags or big bags.

16.5.7.2 Energy consumption

Installations producing natural tartaric acid use both thermal and electrical energy. On average, thermal energy consumption is around 10 000 kWh/tonne while electrical energy consumption on average is about 800 kWh/tonne (of natural tartaric acid produced).

16.5.7.3 Water consumption

Specific water consumption is around 50 m³ per tonne of natural tartaric acid produced.

16.5.7.4 Waste output

The main solid by-products are the gypsum generated during natural tartaric acid extraction (around 2 000 kg in dry matter per tonne of acid produced) and the solid residues produced during waste water treatment, i.e. anaerobic sludge (around 50 kg dry matter per tonne of acid produced).

16.5.7.5 Emissions to water

Before treatment, the waste water generated has high COD levels. It contains salts containing calcium derived from the precipitation of gypsum and the decomposition of calcium tartrate. The waste water is normally treated in an anaerobic reactor.

16.6 Citric acid production

Citric acid, a tricarboxylic acid, exists widely in nature and is produced in almost all living cells as an intermediate substance in the metabolic cycle. Most plant and animal tissues, as well as human serum, contain citric acid in a significant quantity.

16.6.1 Main processes and techniques

The most economical method to produce citric acid is fermentation, which employs a strain of *Aspergillus niger* as an inoculum, to convert sugar to citric acid. The fermentation feedstock or substrate is a carbohydrate, usually molasses, crystalline sugar, glucose from wheat, maize or potato starch, or isomerase. There are two types of fermentation processes, i.e. submerged and surface fermentation. Submerged fermentation is preferred to surface fermentation. Submerged fermentation consists of three main phases, i.e. fermentation, recovery, and purification of citric acid. The flow chart for this process is presented in Figure 16.5. The major environmental issues are water pollution and the generation of solid wastes. During fermentation, a high content of nutrients and oxygen is needed. Further advantages are low concentrations of Fe^{2+} ions and a low pH level which together inhibit the enzyme aconitase that is responsible for the catalysis of citrate to isovitrate [126, Austria 2015].

In citric acid fermentation, the substrate is prepared in a tank and then sterilised. The inoculum is produced under controlled aseptic conditions. The inoculum and the substrate are transferred aseptically to the production fermenter. The fermentation process requires 3 to 14 days. Finally, the biological solids called mycelium are removed by filtration.

In the recovery of citric acid, the dissolved citric acid is separated from residual sugars, proteins and other soluble impurities by the addition of lime, precipitating calcium citrate. Then, the slurry containing calcium citrate is filtered. The filtrate is washed to remove soluble impurities. The waste water generated is discharged. Sulphuric acid is added and this converts the calcium citrate to calcium sulphate and citric acid. Finally, the precipitated calcium sulphate or gypsum is filtered from the slurry and the remaining citric acid solution is further treated.

Ultimately, the citric acid solution is purified by ion exchange and carbon adsorption. The citric acid solution is evaporated and crystallised from the solution (first crystallisation). The citric acid crystals are centrifuged. Later, citric acid is dissolved in water and crystallised again from the solution (second crystallisation). The crystals are centrifuged yet again and are dried, milled and sieved. The resultant citric acid is then packaged.

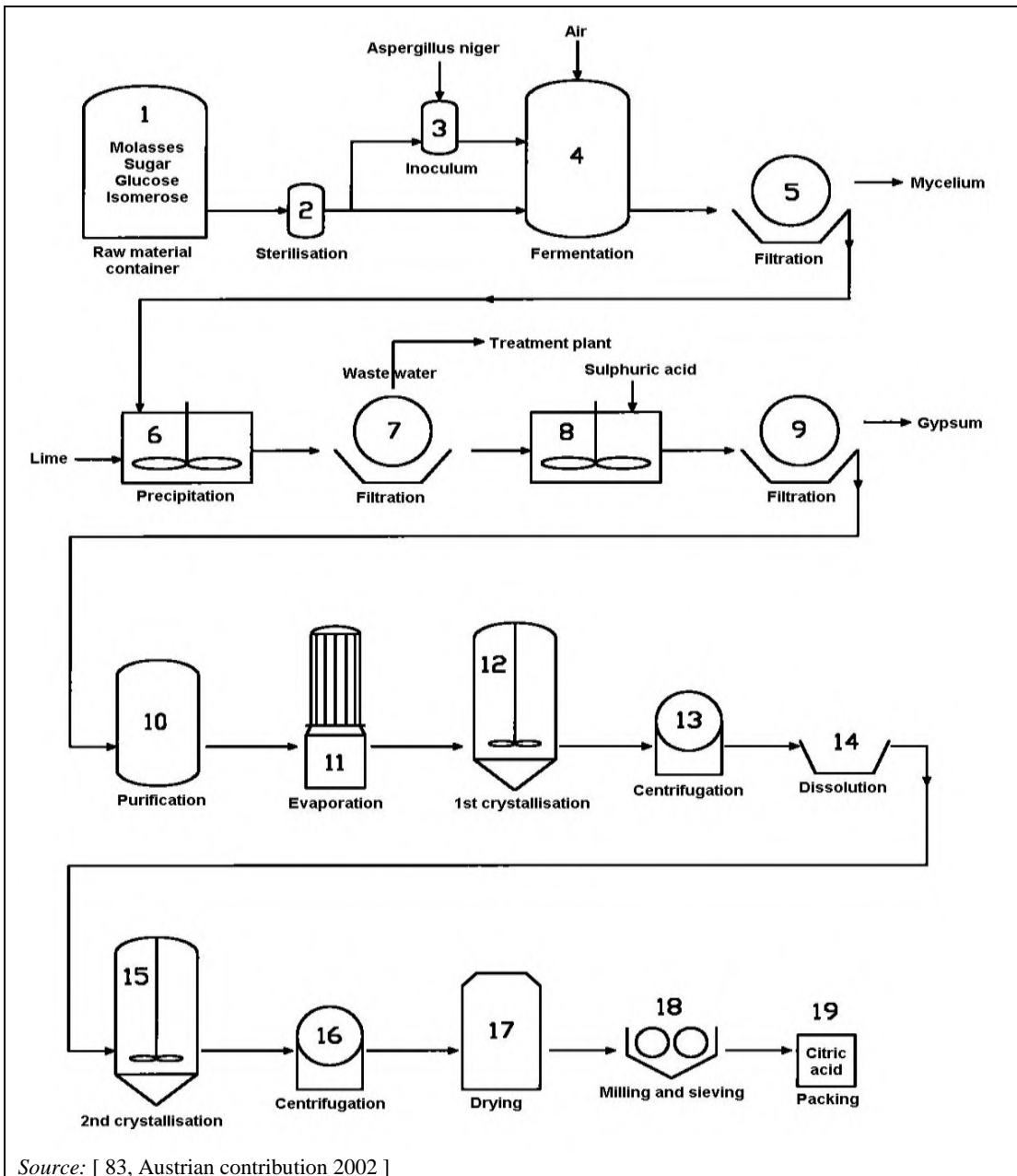

Figure 16.5: Citric acid fermentation process

16.6.2 Water consumption

Specific water consumption is around 40 m³ per tonne of installation citric acid production capacity.

16.6.3 Residues

The main solid wastes are the mycelium of the mould filtered from the fermentation broth, the gypsum generated during citric acid purification and the solid wastes produced during waste water treatment, i.e. anaerobic sludge and sulphur from biogas. Minor quantities of filtering aids are derived from polishing filtration. The solid wastes and by-products from citric acid fermentation are shown in Table 16.4.

Table 16.4: Solid wastes and by-products in the citric acid fermentation process

Solid waste and by-product	Unit	Value
Mycelium	kg dry matter/ t citric acid	100
Gypsum (CaSO ₄ x 2H ₂ O)		1 000
Waste water sludge from anaerobic pretreatment		50
Sulphur from desulphurisation		3–4
<i>Source: [83, Austrian contribution 2002]</i>		

16.6.4 Emissions to water

The waste water generated has high COD levels, compounds containing calcium and sulphur derived from precipitation and decomposition, and a high concentration of NH₄-N from the raw material (molasses) and fermentation [83, Austrian contribution 2002]. About 25 % of the crude waste water volume is highly polluted and represents about 90 % of the total COD load.

The highly polluted waste water is first pretreated using anaerobic digestion, which produces biogas with a high sulphur content. The waste water treated in the anaerobic reactor and other waste water are then mixed and treated further. Waste water pollutant levels, after treatment, per tonne of installed production capacity are shown in Table 16.5.

Table 16.5: Treated waste water pollutant levels per tonne of installed production capacity in citric acid fermentation

Parameter	Unit	Average value
Volume	m ³ /t	40
COD	kg/t	20
BOD ₅	kg/t	1
NH ₄ -N	kg/t	0.2
NO ₂ -N	kg//t	0.08
PO ₄ -P	kg/t	0.04
<i>Source: [83, Austrian contribution 2002]</i>		

A yearly average emission level of 275 mg/l for COD (abatement efficiency 93 %), 12 mg/l for BOD₅ (abatement efficiency 99 %) and 1 mg/l for NH₄-N (abatement efficiency 98 %) have been reported by an Austrian installation [30, TWG 2018].

16.7 Yeast

Yeasts are single-cell fungi used in a wide range of fermentation processes such as baking, brewing and the manufacture of wines and spirits. Yeast is usually supplied to food and ethanol manufacturers either in a crumbled/compressed/liquid form or as active dry yeast. As the production of baker's yeast in particular is the most important industrial large-scale application with respect to volume and environmental impact, the following sections are focused on this. Although methods vary, the essential steps in conventional processing are as described below.

16.7.1 Main processes and techniques

Propagation takes approximately 6 to 8 days on a commercial scale using propagators sized between 90 000 litres and 300 000 litres. Yeast production initially involves a cascade of propagations each increasing in size, the yeast produced at each stage being used to seed the subsequent propagation. Ingredients typically added to the fermenter are cane and beet molasses, blended and clarified before addition, aqueous ammonia, phosphoric acid, vitamins, minerals, defoaming agents and acids for pH control. Aeration of the fermenters is essential to achieve optimum growth. Air is introduced by a series of perforated pipes fitted at the bottom of the vessel. In agitated vessels, air is usually introduced through a doughnut-shaped sparger, located just underneath the stirred blades. In general, 100 grams of dry yeast matter require 102.5 grams of oxygen to be supplied during fermentation. Temperature and acidity are regulated to optimise yields. Typically, fermentation is carried out at 30 °C and at a pH of 4.5–6.5. Cooling water is used in external heat exchangers or internal coils to maintain the fermentation temperature, which otherwise tends to rise due to the yeast growth.

After propagation, cells are harvested from the culture medium by centrifugal separators. The yeast cream is washed with process water to improve its colour and subsequently cooled to a storage temperature below 5 °C. The yeast cream is sold directly to industrial bakers with a dry matter of 18–25 %. Usually, it is further dehydrated by filtration using rotating vacuum filters with a starch precoat. The filter cake is extruded and formed to commercially typical blocks or crumbs with a dry matter content of more than 30 %. Dried yeast is produced in a similar manner but is extruded through a perforated plate to produce strands of around 3 mm in diameter and 0.3–1 cm long. The strips are usually dried in rotary or tunnel dryers before grinding and packaging (dry matter > 95 %). Dried yeast is usually packed in hermetically sealed containers or film with a headspace of nitrogen to extend its active shelf life [17, TWG 2018].

16.7.2 Emissions to water

The main carbon source used in industrial yeast production is cane and beet molasses, a residual of the sugar industry, containing up to 50 % assimilable sugars. A total of 30 % of the dry matter of molasses is not accessible for yeasts and will remain in the culture media after cell harvest. In addition, the washing water from separators and the filtrate from vacuum-filtration end up in the effluent of the production process, leading to an overall COD exceeding 30 000 mg/l, with a total volume of 5–7 m³/t of molasses used. Concentration and volume vary significantly depending on the water consumption at each process step. However, as molasses is the only commercially suitable carbon source, the waste water load of the factories is constant. Besides COD, the effluent of yeast production contains organic nitrogen (1 500 mg/l), nitrate (200 mg/l), phosphorus (40 mg/l) and, depending on the kind of acid used in pH control, up to 3 000 mg/l of sulphur. The effluent of yeast factories has a characteristic brown colour due to the use of molasses. The brown colour originates from the thermal decomposition of cane and beet syrups during the production of sugar, called Maillard products. These compounds are difficult to degrade biologically. Full biological treatment of the effluents will remove COD to a maximum of 80 %, resulting in high residual concentrations in the discharge into surface waters [17, TWG 2018]. High COD levels between 20 000 mg/l and 35 000 mg/l before treatment

(from molasses) and COD emission levels up to 443 mg/l (TOC emission levels up to 121 mg/l) have been reported by a German installation [30, TWG 2018].

It has been shown to be more efficient and ecologically beneficial to use evaporation as a pretreatment technique for yeast effluent. More than 95 % of the COD and nitrogen are removed. Phosphorus and sulphur are removed completely. The distillate or condensate from evaporation contains small amounts of simple organic acids, traces of alcohols and some ammonia (depending on the pH during evaporation). It is colourless and free of suspended solids. The residues of the evaporation can be separated into a salt-free fraction, called vinasse, and a salt fraction mainly consisting of potassium sulphate. Vinasse is used as cattle feed; the salt is used as a fertiliser.

As evaporation is an energy-consuming treatment step and therefore rather uncommon in waste water treatment, technical improvements have been implemented in the past 10 years and it has now been adopted in most factories. The effluent is first concentrated by means of a falling film evaporator (vertical shell and tube type) and mechanical vapour recompression. The effluent is concentrated from originally 3–6 % dry matter to a maximum of 20 % dry matter. As the viscosity of the concentrate increases, a higher concentration cannot be obtained by this technique. The semi-concentrate is stable enough for storage and can be used as a fertiliser, if farmland is close to the site and transport economically feasible. If higher concentrations are desired, a forced-circulation evaporator is needed, working on fresh steam and therefore more expensive. Evaporation up to 75 % dry matter is feasible. As the solubility limit of potassium sulphate is exceeded, crystals can be isolated by centrifugation (decanter), generating a more valuable feed product. Distillates from both types of evaporators can be treated aerobically or, more commonly, anaerobically by UASB or EGSB reactors. Anaerobic treatment generates a Sulphur-free biogas and only small amounts of surplus sludge. A drawback is a small increase of suspended solids [17, TWG 2018].

Overall, the techniques described are ecologically beneficial due to the generation of recyclable end products. Although evaporation is energy-consuming, it has shown to be economically feasible. Moreover, it offers the only applied technique able to generate efficiency rates exceeding 90 % for all substances in yeast effluent.

16.8 Confectionery

16.8.1 Main processes and techniques

Biscuits

The principal ingredients used in the manufacture of biscuits are wheat flour, fat and sugar. Water plays an important role in the biscuit-making process but is largely removed during baking. Baked goods are normally decorated and ingredients like dried and fresh fruit, cream and custard are utilised.

The two basic dough types are hard doughs and short doughs. Whatever the dough type, the basic process steps involved in the manufacture of biscuits are dough mixing, formation of the dough pieces, baking, cooling and packaging. The methods used at each stage vary considerably depending on the product type. Raw materials are usually received in bulk and automatically metered into dough mixers. Small ingredients such as salt and sodium bicarbonate may be weighed and added by hand. The ingredients are blended and, in the case of hard doughs, mixed to promote a gluten network in the dough. In the case of short doughs, mixing is such that gluten development is deliberately limited. The formation of dough pieces varies depending on the biscuit type. Crackers and semi-sweet biscuits are cut from continuous sheets of rolled hard dough. Crackers require considerable processing as they are built up in a series of thin layers. Most short doughs are formed by rotary moulding, but soft doughs for biscuits are usually wire-cut. The biscuits are baked, usually in tunnel ovens. The times and temperatures used vary depending on the product. Ovens may be directly or indirectly fired, gas or electric. The baked biscuits are cooled and packed or transferred for secondary processing, e.g. layering of cream fillings. Crackers may be oil-sprayed immediately after baking. Cooling is typically achieved by conveying the biscuits around the installation for a set time period.

Cakes

The main ingredients used in the manufacture of cake are wheat flour, fat, eggs, sugar, milk powder, water flavourings and raising agents. Cakes are generally made using either the sugar batter or flour batter method. In the sugar batter method, the fat and sugar are creamed together and eggs are added in stages. Several alternate additions of flour and liquid are carried out throughout the mixing. In the flour batter method, the fat and flour are blended together. The eggs and sugar are whisked together and then blended into the fat and flour in stages. The required quantities of liquids are then added in small amounts as mixing progresses.

In continuous mixing systems such as the Oakes and Mondo cake mixers, the ingredients are given a preliminary mix and then fed, in a continuous even stream, into the head of the mixer. All-in high-speed cake mixing is increasingly being used. In this method, all ingredients except fruit are added and a fixed amount of mixing is carried out. The fruit is then added in short bursts.

Batters are typically deposited into oil-sprayed trays or onto continuous sheets for products such as Swiss rolls. After baking, the cakes are removed from the tins and cooled. The empty tins are cleaned, rinsed, dried and cooled.

Cocoa

Drinking cocoa typically consists of cocoa powder, vanillin, cinnamon, salt, cassia and other powdered spices. Raw beans are received and subjected to a series of washing operations to remove extraneous matter such as fibre, stones, grit, metal, bean clusters and immature beans. The latter two materials may be used for the manufacture of cocoa butter. The beans are roasted. Roasting conditions vary depending on the equipment and the desired product, but are typically in the range of 100–140 °C for 4 to 6 minutes. Whole beans or the separated nibs may be roasted.

Winnowing is the separation of the outer shell of the bean from the edible nibs and typically consists of cracking the roasted bean between rollers, followed by air classification to remove

the shell fragments. The nibs are ground to produce a cocoa liquor whose particle size is further reduced by grinding mills, which are water-cooled. The particle size is important for the manufacture of chocolate drinks but less important for chocolate since this requires some further refining. The liquor or nibs from roasted or unroasted beans are likely to be subjected to a process known as alkalisation which increases the dispensability of cocoa powder in milk or water when used in drinks. It is also used to modify the colour of the cocoa. Only permitted acids, alkalis and emulsifiers may be used for this process.

Cocoa powder is produced by the hydraulic pressing of cocoa liquor to express cocoa butter and to reduce the fat content of the press cake to the desired level. The expressed cocoa butter is used in the manufacture of chocolate. The press cake is pulverised to produce a cocoa powder. The final product is then packaged.

Chocolate

The basic ingredients for the manufacture of chocolate include cocoa liquor, sugar, other sweeteners, cocoa butter, butter fat, milk powder, milk crumb and emulsifiers. The basic operations involved in chocolate production are the preparation and mixing of ingredients, refining and conching. Conching involves agitating the refined material to induce desirable physical changes in the final product and to improve the flavour. Chocolate production has traditionally been undertaken in a device called a melangeur, which accommodates all of the steps involved. Melangeurs are, however, increasingly being replaced by large specialist machines.

The refining stage in the manufacture of chocolate is intended to reduce the size of the particles of cocoa solids in the mix, thus ensuring that the mixture has a smooth consistency. This is achieved by passing the mixture through vertically mounted rollers which need to be water-cooled to prevent distortions arising from frictional heating. A number of systems are available for conching, which is a specialised activity inducing complex changes in the chocolate. Processing milk chocolate in a traditional batch conch takes in excess of a day, whilst modern continuous systems achieve the same result in around 4 hours. Finished chocolate is typically stored in bulk and is tempered through a cooling and warming cycle before final use.

Chocolate products may be produced by casting the chocolate into moulds, followed by cooling and demoulding. Such methods may be used to produce solid chocolate blocks or shells, which may be hollow or filled with a filling such as fondant. Alternatively, liquid chocolate may be used to coat confectionery using units known as enrobers.

Boiled sweets

Boiled sweets are highly concentrated solutions of sugar, glucose syrup and sometimes invert sugar, with added flavourings. These are metered into continuous dissolvers. This mixture feeds cookers, of which there are a number of designs such as thin film coil cookers or batch vacuum cookers. Water is rapidly evaporated from the syrup, which is then discharged and partially cooled due to evaporative cooling. The boiled sweet mass is transferred to water-cooled tables and acid, flavour and colours are added to the partially cooled mass in a batch or continuous process. The mix is then transferred to forming machinery. The sweets formed are cooled and wrapped in moisture-proof packs as rapidly as possible.

For additional information consult the Sectoral Reference Document on Best Environmental Management Practices for the food and beverage manufacturing sector [[107, COM 2017](#)].

16.9 Malting

Malt is made from malting-grade cereals, usually barley or wheat, although occasionally other cereals such as rye and oats may be used. There are five product groups:

- white malts (malted barley, malted wheat, malted oats, malted sorghum, high enzymatic malt);
- peated or smoked malt;
- coloured malts (such as crystal and caramel malts);
- roasted malts (range including both light and dark roasts);
- roasted barley.

Malt extracts are fermented to make beers or may be fermented and then distilled to make spirits such as whisky. Malts are also used in a range of foods such as malted milk drinks, breakfast cereals, breads, biscuits, cakes, vinegar, confectionery, sauces, baby foods, as well as animal feeds and cosmetics.

The information source for this sector is [197, EUROMALT 2015].

16.9.1 Main processes and techniques

The main processes applied in malting installations are cleaning, steeping, germination and kilning. Malts may also be roasted.

Cleaning

Barley and other cereals received directly from the field are first cleaned to remove foreign material. This may include dust, soil, stone, metal, etc. Cleaned grain is then screened to remove broken or undersized grains, loose husks and cereal fines. This material is collected and used in animal feed.

Steeping

To steep the grain, the grain is immersed in water at a temperature of about 16 °C, or at least ranging from 10 °C to 25 °C, depending on the equipment, the process parameters, the raw material and the finished malt to be obtained. During steeping, the moisture content increases from 12–15 % to anywhere between 30 % and 50 %, depending again on the above conditions. During steeping, the water in the steep tanks is changed up to three times. Alternate wet and dry stages are applied. During the wet stage, the grain is aerated continuously or at intervals. During the dry stage, the grain can be aerated or the CO₂ can be extracted. The steeping process takes one to three days. The actual temperature and steeping periods depend on the equipment, the process parameters, the raw material and the finished malt to be obtained.

Germination

The cleaned, steeped grain is then transferred into germination vessels with perforated steel plate floors for pneumatic malting, or onto germination floors for floor malting. The grain is layered from about 70 cm to 150 cm thick for pneumatic malting and from about 5 cm to 15 cm for floor malting. The germination step generally lasts between 96 and 200 hours. Depending on the equipment, the process parameters, the raw material and the finished malt to be obtained, the germination process can be shorter or longer. Conditioned air, i.e. cooled or heated and humidified, is blown through the grain layer in pneumatic malting, or over it in floor malting, to control the temperature and the moisture content during germination. To prevent the grain kernels from matting or felting, the layer of grain is turned from time to time, during which water spraying can also be applied. The germination process is stopped by drying.

Kilning

The resulting green malt is air-dried in kilns. Hot air is blown through a layer of green malt of about 50–150 cm thickness, without any fluidisation of the batch. This drying process lasts around 16 to 48 hours. For pale malts, resulting in a moisture content of 3–6.5 %, the starting air temperature is around 50 °C and it is increased to around 70–85 °C. To obtain darker malts, with lower moisture levels, the temperature is increased further to 130 °C. Kilning is carried out in several stages to ensure that moisture is removed effectively without unduly reducing the enzymatic activity. In general, the air flow rate reduces and the air temperature increases as the kilning progresses.

Malts may be roasted to increase the colour and flavour as required for certain applications. Roasting will take place in small batches, and involves heating to temperatures from 130 °C to 230 °C depending on the specifications of the finished product. Crystal malts are produced by roasting of green (partially germinated) malts after an amylolytic stand at around 65 °C. Malt intended for distillation may have peat smoke introduced into the airflow through the malt kiln, to give the particular characteristics needed by the whisky to be made from it. Other smokes may be used to give different characteristics for beers and other malt products.

16.9.2 Energy consumption

The kilning and roasting processes rely on thermal energy and electrical power. Natural gas is the usual primary fuel, with gas oil or fuel oil as alternatives.

16.9.3 Water consumption

Water is a key input material to the steeping and the germination process.

16.9.4 Residues

The by-products of the malting process are widely used in the animal feed industry. They comprise blends of:

- malting barley screenings;
- malting wheat screenings;
- malting barley husks;
- malting wheat husks;
- malting barley and malt fines;
- malting wheat and malt fines;
- malt rootlets (culms);
- wheat rootlets.

16.9.5 Emissions to water

Emissions to water may include waste steep water, although this is often treated before discharge or sent to a treatment works.

16.9.6 Emissions to air

There are emissions from the malting process to air, including CO₂ from combustion in heating process air, short-cycle CO₂ from germination, NO_x from combustion, SO₂ if used in kilning and anyway if fuel oil is the primary fuel, dust and particulate matter from aspiration systems and cyclones, VOC from roasting and germination, and odour from kilning and roasting.

17 BEST AVAILABLE TECHNIQUES (BAT) CONCLUSIONS FOR THE FOOD, DRINK AND MILK INDUSTRIES

SCOPE

These BAT conclusions concern the following activities specified in Annex I to Directive 2010/75/EU:

- 6.4 (b) Treatment and processing, other than exclusively packaging, of the following raw materials, whether previously processed or unprocessed, intended for the production of food or feed from:
 - (i) only animal raw materials (other than exclusively milk) with a finished product production capacity greater than 75 tonnes per day;
 - (ii) only vegetable raw materials with a finished product production capacity greater than 300 tonnes per day or 600 tonnes per day where the installation operates for a period of no more than 90 consecutive days in any year;
 - (iii) animal and vegetable raw materials, both in combined and separate products, with a finished product production capacity in tonnes per day greater than:
 - 75 if A is equal to 10 or more; or,
 - $[300 - (22.5 \times A)]$ in any other case,
 where 'A' is the portion of animal material (in percent of weight) of the finished product production capacity.

Packaging shall not be included in the final weight of the product.

This subsection shall not apply where the raw material is milk only.

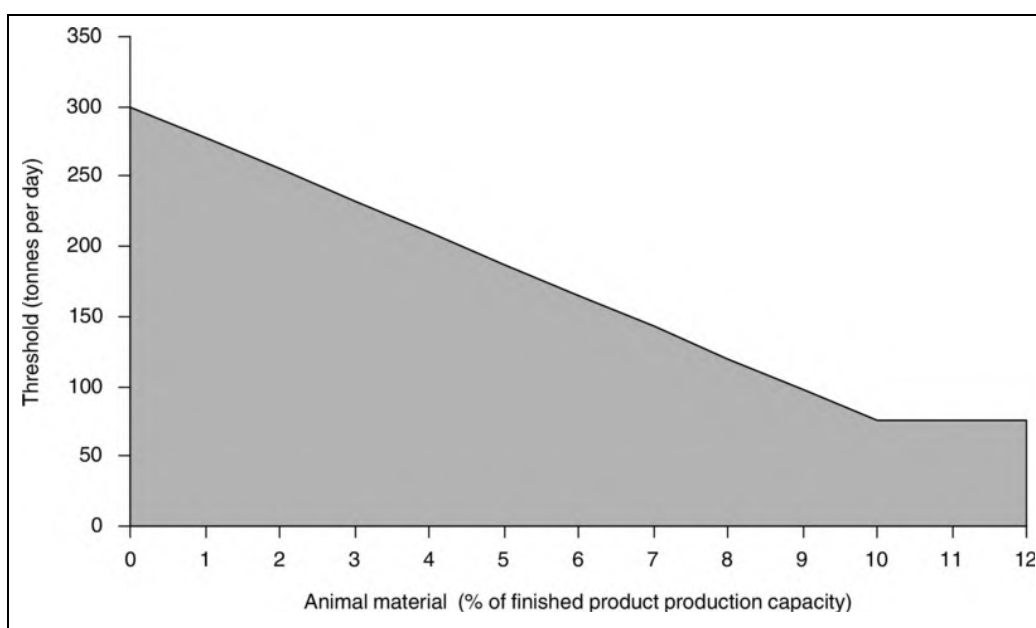

- 6.4 (c) Treatment and processing of milk only, the quantity of milk received being greater than 200 tonnes per day (average value on an annual basis).

- 6.11 Independently operated treatment of waste water not covered by Directive 91/271/EEC⁵ provided that the main pollutant load originates from activities specified in points 6.4 (b) or (c) of Annex I to Directive 2010/75/EU.

These BAT conclusions also cover:

- the combined treatment of waste water from different origins provided that the main pollutant load originates from the activities specified in point 6.4 (b) or 6.4 (c) of Annex I to Directive 2010/75/EU and that the waste water treatment is not covered by Council Directive 91/271/EEC;
- the production of ethanol taking place on an installation covered by the activity description in point 6.4 (b) (ii) of Annex I to Directive 2010/75/EU or as a directly associated activity to such an installation.

These BAT conclusions do not address the following:

- On-site combustion plants generating hot gases that are not used for direct contact heating, drying or any other treatment of objects or materials. This may be covered by the BAT conclusions for Large Combustion Plants (LCP) or by Directive (EU) 2015/2193 of the European Parliament and of the Council⁶.
- Production of primary products from animal by-products, such as rendering and fat melting, fish-meal and fish oil production, blood processing and gelatine manufacturing. This may be covered by the BAT conclusions for Slaughterhouses and Animal By-products Industries (SA).
- The making of standard cuts for large animals and cuts for poultry. This may be covered by the BAT conclusions for Slaughterhouses and Animal By-products Industries (SA).

Other BAT conclusions and reference documents which could be relevant for the activities covered by these BAT conclusions include the following:

- Large Combustion Plants (LCP);
- Slaughterhouses and Animal By-products Industries (SA);
- Common Waste Water and Waste Gas Treatment/Management Systems in the Chemical Sector (CWW);
- Large Volume Organic Chemical Industry (LVOC);
- Waste Treatment (WT);
- Production of Cement, Lime and Magnesium Oxide (CLM);
- Monitoring of Emissions to Air and Water from IED Installations (ROM);
- Economics and Cross-Media Effects (ECM);
- Emissions from Storage (EFS);
- Energy Efficiency (ENE);
- Industrial Cooling Systems (ICS).

These BAT conclusions apply without prejudice to other relevant legislation, e.g. on hygiene or food/feed safety.

⁵ Council Directive 91/271/EEC of 21 May 1991 concerning urban waste-water treatment (OJ L 135, 30.5.1991, p. 40).

⁶ Directive (EU) 2015/2193 of the European Parliament and of the Council of 25 November 2015 on the limitation of emissions of certain pollutants into the air from medium combustion plants (OJ L 313, 28.11.2015, p. 1).

DEFINITIONS

For the purposes of these BAT conclusions, the following definitions apply:

Term used	Definition
Biochemical oxygen demand (BOD _n)	Amount of oxygen needed for the biochemical oxidation of the organic matter to carbon dioxide in <i>n</i> days (<i>n</i> is typically 5 or 7). BOD is an indicator for the mass concentration of biodegradable organic compounds.
Channelled emissions	Emissions of pollutants into the environment through any kind of duct, pipe, stack, etc.
Chemical oxygen demand (COD)	Amount of oxygen needed for the total chemical oxidation of the organic matter to carbon dioxide using dichromate. COD is an indicator for the mass concentration of organic compounds.
Dust	Total particulate matter (in air).
Existing plant	A plant that is not a new plant.
Hexane	Alkane of six carbon atoms, with the chemical formula C ₆ H ₁₄ .
hl	Hectolitre (equal to 100 litres).
New plant	A plant first permitted at the site of the installation following the publication of these BAT conclusions or a complete replacement of a plant following the publication of these BAT conclusions.
NO _x	The sum of nitrogen monoxide (NO) and nitrogen dioxide (NO ₂), expressed as NO ₂ .
Residue	Substance or object generated by the activities covered by the scope of this document, as waste or by-product.
SO _x	The sum of sulphur dioxide (SO ₂), sulphur trioxide (SO ₃), and sulphuric acid aerosols, expressed as SO ₂ .
Sensitive receptor	Areas which need special protection, such as: - residential areas; - areas where human activities are carried out (e.g. neighbouring workplaces, schools, day-care centres, recreational areas, hospitals or nursing homes).
Total nitrogen (TN)	Total nitrogen, expressed as N, includes free ammonia and ammonium nitrogen (NH ₄ -N), nitrite nitrogen (NO ₂ -N), nitrate nitrogen (NO ₃ -N) and organically bound nitrogen.
Total organic carbon (TOC)	Total organic carbon, expressed as C (in water), includes all organic compounds.
Total phosphorus (TP)	Total phosphorus, expressed as P, includes all inorganic and organic phosphorus compounds, dissolved or bound to particles.
Total suspended solids (TSS)	Mass concentration of all suspended solids (in water), measured via filtration through glass fibre filters and gravimetry.
Total volatile organic carbon (TVOC)	Total volatile organic carbon, expressed as C (in air).

GENERAL CONSIDERATIONS

Best Available Techniques

The techniques listed and described in these BAT conclusions are neither prescriptive nor exhaustive. Other techniques may be used that ensure at least an equivalent level of environmental protection.

Unless otherwise stated, the BAT conclusions are generally applicable.

Emission levels associated with the best available techniques (BAT-AELs) for emissions to air

Unless otherwise stated, emission levels associated with the best available techniques (BAT-AELs) for emissions to air given in these BAT conclusions refer to concentrations, expressed as mass of emitted substances per volume of waste gas under the following standard conditions: dry gas at a temperature of 273.15 K and a pressure of 101.3 kPa, without correction for oxygen content, and expressed in mg/Nm³.

The equation for calculating the emission concentration at the reference oxygen level is:

$$E_R = \frac{21 - O_R}{21 - O_M} \times E_M$$

where: E_R : emission concentration at the reference oxygen level O_R ;
 O_R : reference oxygen level in vol-%;
 E_M : measured emission concentration;
 O_M : measured oxygen level in vol-%.

For averaging periods of BAT-AELs for emissions to air, the following definition applies.

Averaging period	Definition
Average over the sampling period	Average value of three consecutive measurements of at least 30 minutes each ⁽¹⁾ .
⁽¹⁾ For any parameter where, due to sampling or analytical limitations, 30-minute sampling/measurement is inappropriate, a more suitable measurement period may be employed.	

When the waste gases of two or more sources (e.g. dryers or kilns) are discharged through a common stack, the BAT-AEL applies to the combined discharge from the stack.

Specific hexane losses

The emission levels associated with the best available techniques (BAT-AELs) related to specific hexane losses refer to yearly averages and are calculated using the following equation:

$$\text{specific hexane losses} = \frac{\text{hexane losses}}{\text{raw materials}}$$

where: hexane losses is the total amount of hexane consumed by the installation for each type of seeds or beans, expressed in kg/year;

raw materials is the total amount of each type of cleaned seeds or beans processed, expressed in tonnes/year.

Emission levels associated with the best available techniques (BAT-AELs) for emissions to water

Unless otherwise stated, emission levels associated with the best available techniques (BAT-AELs) for emissions to water given in these BAT conclusions refer to concentrations (mass of emitted substances per volume of water), expressed in mg/l.

The BAT-AELs expressed as concentrations refer to daily average values, i.e. 24-hour flow-proportional composite samples. Time-proportional composite samples can be used provided that sufficient flow stability is demonstrated. Alternatively, spot samples may be taken, provided that the effluent is appropriately mixed and homogeneous.

In the case of total organic carbon (TOC), chemical oxygen demand (COD), total nitrogen (TN) and total phosphorus (TP), the calculation of the average abatement efficiency referred to in these BAT conclusions (see Table 17.1) is based on the influent and effluent load of the waste water treatment plant.

Other environmental performance levels

Specific waste water discharge

The indicative environmental performance levels related to specific waste water discharge refer to yearly averages and are calculated using the following equation:

$$\text{specific waste water discharge} = \frac{\text{waste water discharge}}{\text{activity rate}}$$

where: Waste water discharge is the total amount of waste water discharged (as direct discharge, indirect discharge and/or land spreading) by the specific processes concerned during the production period, expressed in m³/year, excluding any cooling water and run-off water that is discharged separately.

Activity rate is the total amount of products or raw materials processed, depending on the specific sector, expressed in tonnes/year or hl/year. Packaging is not included in the weight of the product. Raw material is any material entering the plant, treated or processed for the production of food or feed.

Specific energy consumption

The indicative environmental performance levels related to specific energy consumption refer to yearly averages and are calculated using the following equation:

$$\text{specific energy consumption} = \frac{\text{final energy consumption}}{\text{activity rate}}$$

where: Final energy consumption is the total amount of energy consumed by the specific processes concerned during the production period (in the form of heat and electricity), expressed in MWh/year.

Activity rate is the total amount of products or raw materials processed, depending on the specific sector, expressed in tonnes/year or hl/year. Packaging is not included in the weight of the product. Raw material is any material entering the plant, treated or processed for the production of food or feed.

17.1 General BAT conclusions

17.1.1 Environmental management systems

BAT 1. In order to improve the overall environmental performance, BAT is to elaborate and implement an environmental management system (EMS) that incorporates all of the following features:

- i. commitment, leadership, and accountability of the management, including senior management, for the implementation of an effective EMS;
- ii. an analysis that includes the determination of the organisation's context, the identification of the needs and expectations of interested parties, the identification of characteristics of the installation that are associated with possible risks for the environment (or human health) as well as of the applicable legal requirements relating to the environment;
- iii. development of an environmental policy that includes the continuous improvement of the environmental performance of the installation;
- iv. establishing objectives and performance indicators in relation to significant environmental aspects, including safeguarding compliance with applicable legal requirements;
- v. planning and implementing the necessary procedures and actions (including corrective and preventive actions where needed), to achieve the environmental objectives and avoid environmental risks;
- vi. determination of structures, roles and responsibilities in relation to environmental aspects and objectives and provision of the financial and human resources needed;
- vii. ensuring the necessary competence and awareness of staff whose work may affect the environmental performance of the installation (e.g. by providing information and training);
- viii. internal and external communication;
- ix. fostering employee involvement in good environmental management practices;
- x. Establishing and maintaining a management manual and written procedures to control activities with significant environmental impact as well as relevant records;
- xi. effective operational planning and process control;
- xii. implementation of appropriate maintenance programmes;
- xiii. emergency preparedness and response protocols, including the prevention and/or mitigation of the adverse (environmental) impacts of emergency situations;
- xiv. when (re)designing a (new) installation or a part thereof, consideration of its environmental impacts throughout its life, which includes construction, maintenance, operation and decommissioning;
- xv. implementation of a monitoring and measurement programme, if necessary, information can be found in the Reference Report on Monitoring of Emissions to Air and Water from IED Installations;
- xvi. application of sectoral benchmarking on a regular basis;
- xvii. periodic independent (as far as practicable) internal auditing and periodic independent external auditing in order to assess the environmental performance and to determine whether or not the EMS conforms to planned arrangements and has been properly implemented and maintained;
- xviii. evaluation of causes of nonconformities, implementation of corrective actions in response to nonconformities, review of the effectiveness of corrective actions, and determination of whether similar nonconformities exist or could potentially occur;
- xix. periodic review, by senior management, of the EMS and its continuing suitability, adequacy and effectiveness;
- xx. following and taking into account the development of cleaner techniques.

Specifically for the food, drink and milk sector, BAT is to also incorporate the following features in the EMS:

- i. noise management plan (see BAT 13);
- ii. odour management plan (see BAT 15);
- iii. inventory of water, energy and raw materials consumption as well as of waste water and waste gas streams (see BAT 2);
- iv. energy efficiency plan (see BAT 6a).

Note

Regulation (EC) No 1221/2009 of the European Parliament and of the Council⁷ establishes the Union eco-management and audit scheme (EMAS), which is an example of an EMS consistent with this BAT.

Applicability

The level of detail and the degree of formalisation of the EMS will generally be related to the nature, scale and complexity of the installation, and the range of environmental impacts it may have.

BAT 2. In order to increase resource efficiency and to reduce emissions, BAT is to establish, maintain and regularly review (including when a significant change occurs) an inventory of water, energy and raw materials consumption as well as of waste water and waste gas streams, as part of the environmental management system (see BAT 1), that incorporates all of the following features:

- I. Information about the food, drink and milk production processes, including:
 - (a) simplified process flow sheets that show the origin of the emissions;
 - (b) descriptions of process-integrated techniques and waste water/waste gas treatment techniques to prevent or reduce emissions, including their performance.
- II. Information about water consumption and usage (e.g. flow diagrams and water mass balances), and identification of actions to reduce water consumption and waste water volume (see BAT 7).
- III. Information about the quantity and characteristics of the waste water streams, such as:
 - (a) average values and variability of flow, pH and temperature;
 - (b) average concentration and load values of relevant pollutants/parameters (e.g. TOC or COD, nitrogen species, phosphorus, chloride, conductivity) and their variability.
- IV. Information about the characteristics of the waste gas streams, such as:
 - (a) average values and variability of flow and temperature;
 - (b) average concentration and load values of relevant pollutants/parameters (e.g. dust, TVOC, CO, NO_x, SO_x) and their variability;
 - (c) presence of other substances that may affect the waste gas treatment system or plant safety (e.g. oxygen, water vapour, dust).

⁷ Regulation (EC) No 1221/2009 of the European Parliament and of the Council of 25 November 2009 on the voluntary participation by organisations in a Community eco-management and audit scheme (EMAS), repealing Regulation (EC) No 761/2001 and Commission Decisions 2001/681/EC and 2006/193/EC (OJ L 342, 22.12.2009, p. 1).

- V. Information about energy consumption and usage, the quantity of raw materials used, as well as the quantity and characteristics of residues generated, and identification of actions for continuous improvement of resource efficiency (see for example BAT 6 and BAT 10).
- VI. Identification and implementation of an appropriate monitoring strategy with the aim of increasing resource efficiency, taking into account energy, water and raw materials consumption. Monitoring can include direct measurements, calculations or recording with an appropriate frequency. The monitoring is broken down at the most appropriate level (e.g. at process or plant/installation level).

Applicability

The level of detail of the inventory will generally be related to the nature, scale and complexity of the installation, and the range of environmental impacts it may have.

17.1.2 Monitoring

BAT 3. For relevant emissions to water as identified by the inventory of waste water streams (see BAT 2), BAT is to monitor key process parameters (e.g. continuous monitoring of waste water flow, pH and temperature) at key locations (e.g. at the inlet and/or outlet of the pre-treatment, at the inlet to the final treatment, at the point where the emission leaves the installation).

BAT 4. BAT is to monitor emissions to water with at least the frequency given below and in accordance with EN standards. If EN standards are not available, BAT is to use ISO, national or other international standards that ensure the provision of data of an equivalent scientific quality.

Substance/parameter	Standard(s)	Minimum monitoring frequency ⁽¹⁾	Monitoring associated with
Chemical oxygen demand (COD) ⁽²⁾ ⁽³⁾	No EN standard available	Once every day ⁽⁴⁾	BAT 12
Total nitrogen (TN) ⁽²⁾	Various EN standards available (e.g. EN 12260, EN ISO 11905-1)		
Total organic carbon (TOC) ⁽²⁾ ⁽³⁾	EN 1484		
Total phosphorus (TP) ⁽²⁾	Various EN standards available (e.g. EN ISO 6878, EN ISO 15681-1 and -2, EN ISO 11885)		
Total suspended solids (TSS) ⁽²⁾	EN 872		
Biochemical oxygen demand (BOD _n) ⁽²⁾	EN 1899-1	Once every month	
Chloride (Cl)	Various EN standards available (e.g. EN ISO 10304-1, EN ISO 15682)	Once every month	—
⁽¹⁾ The monitoring only applies when the substance concerned is identified as relevant in the waste water stream based on the inventory mentioned in BAT 2. ⁽²⁾ The monitoring only applies in the case of a direct discharge to a receiving water body. ⁽³⁾ TOC monitoring and COD monitoring are alternatives. TOC monitoring is the preferred option because it does not rely on the use of very toxic compounds. ⁽⁴⁾ If the emission levels are proven to be sufficiently stable, a lower monitoring frequency can be adopted but in any case at least once every month.			

BAT 5. BAT is to monitor channelled emissions to air with at least the frequency given below and in accordance with EN standards.

Substance/ Parameter	Sector	Specific process	Standard(s)	Minimum monitoring frequency (¹)	Monitoring associated with
Dust	Animal feed	Drying of green fodder	EN 13284-1	Once every three months (²)	BAT 17
		Grinding and pellet cooling in compound feed manufacture		Once every year	BAT 17
		Extrusion of dry pet food		Once every year	BAT 17
	Brewing	Handling and processing of malt and adjuncts		Once every year	BAT 20
	Dairies	Drying processes		Once every year	BAT 23
	Grain milling	Grain cleaning and milling		Once every year	BAT 28
	Oilseed processing and vegetable oil refining	Handling and preparation of seeds, drying and cooling of meal		Once every year	BAT 31
	Starch production	Drying of starch, protein and fibre		Once every month (²)	BAT 36
Sugar manufacturing	Drying of beet pulp	Once every year	BAT 36		
PM _{2.5} and PM ₁₀	Sugar manufacturing	Drying of beet pulp	EN ISO 23210	Once every year	BAT 36
TVOC	Fish and shellfish processing	Smoke chambers	EN 12619	Once every year	BAT 26
	Meat processing	Smoke chambers			BAT 29
	Oilseed processing and vegetable oil refining (³)	—			—
	Sugar manufacturing	High-temperature drying of beet pulp		Once every year	—
NO _x	Meat processing (⁴)	Smoke chambers	EN 14792	Once every year	—
	Sugar manufacturing	High-temperature drying of beet pulp			
CO	Meat processing (⁴)	Smoke chambers	EN 15058		
	Sugar manufacturing	High-temperature drying of beet pulp			
SO _x	Sugar manufacturing	Drying of beet pulp when natural gas is not used	EN 14791	Twice every year (²)	BAT 37
<p>(¹) The measurements are carried out at the highest expected emission state under normal operating conditions. (²) If the emission levels are proven to be sufficiently stable, a lower monitoring frequency can be adopted but in any case at least once every year. (³) The measurement is carried out during a campaign of two days. (⁴) The monitoring only applies when a thermal oxidiser is used.</p>					

17.1.3 Energy efficiency

BAT 6. In order to increase energy efficiency, BAT is to use BAT 6a and an appropriate combination of the common techniques listed in technique b below.

Technique		Description
a	Energy efficiency plan	An energy efficiency plan, as part of the environmental management system (see BAT 1), entails defining and calculating the specific energy consumption of the activity (or activities), setting key performance indicators on an annual basis (for example for the specific energy consumption) and planning periodic improvement targets and related actions. The plan is adapted to the specificities of the installation.
b	Use of common techniques	Common techniques include techniques such as: <ul style="list-style-type: none"> - burner regulation and control; - cogeneration; - energy-efficient motors; - heat recovery with heat exchangers and/or heat pumps (including mechanical vapour recompression); - lighting; - minimising blowdown from the boiler; - optimising steam distribution systems; - preheating feed water (including the use of economisers); - process control systems; - reducing compressed air system leaks; - reducing heat losses by insulation; - variable speed drives; - multiple-effect evaporation; - use of solar energy.

Further sector-specific techniques to increase energy efficiency are given in Sections 17.2 to 17.13 of these BAT conclusions.

17.1.4 Water consumption and waste water discharge

BAT 7. In order to reduce water consumption and the volume of waste water discharged, BAT is to use BAT 7a and one or a combination of the techniques b to k given below.

Technique		Description	Applicability
<i>Common techniques</i>			
a	Water recycling and/or reuse	Recycling and/or reuse of water streams (preceded or not by water treatment), e.g. for cleaning, washing, cooling or for the process itself.	May not be applicable due to hygiene and food safety requirements.
b	Optimisation of water flow	Use of control devices, e.g. photocells, flow valves, thermostatic valves, to automatically adjust the water flow.	
c	Optimisation of water nozzles and hoses	Use of correct number and position of nozzles; adjustment of water pressure.	
d	Segregation of water streams	Water streams that do not need treatment (e.g. uncontaminated cooling water or uncontaminated run-off water) are segregated from waste water that has to undergo treatment, thus enabling uncontaminated water recycling.	The segregation of uncontaminated rainwater may not be applicable in the case of existing waste water collection systems.
<i>Techniques related to cleaning operations</i>			
e	Dry cleaning	Removal of as much residual material as possible from raw materials and equipment before they are cleaned with liquids, e.g. by using compressed air, vacuum systems or catchpots with a mesh cover.	Generally applicable.
f	Pigging system for pipes	Use of a system made of launchers, catchers, compressed air equipment, and a projectile (also referred to as a 'pig', e.g. made of plastic or ice slurry) to clean out pipes. In-line valves are in place to allow the pig to pass through the pipeline system and to separate the product and the rinsing water.	
g	High-pressure cleaning	Spraying of water onto the surface to be cleaned at pressures ranging from 15 bar to 150 bar.	May not be applicable due to health and safety requirements.
h	Optimisation of chemical dosing and water use in cleaning-in-place (CIP)	Optimising the design of CIP and measuring turbidity, conductivity, temperature and/or pH to dose hot water and chemicals in optimised quantities.	Generally applicable.
i	Low-pressure foam and/or gel cleaning	Use of low-pressure foam and/or gel to clean walls, floors and/or equipment surfaces.	
j	Optimised design and construction of equipment and process areas	The equipment and process areas are designed and constructed in a way that facilitates cleaning. When optimising the design and construction, hygiene requirements are taken into account.	
k	Cleaning of equipment as soon as possible	Cleaning is applied as soon as possible after use of equipment to prevent wastes hardening.	

Further sector-specific techniques to reduce water consumption are given in Section 17.6.1 of these BAT conclusions.

17.1.5 Harmful substances

BAT 8. In order to prevent or reduce the use of harmful substances, e.g. in cleaning and disinfection, BAT is to use one or a combination of the techniques given below.

Technique		Description
a	Proper selection of cleaning chemicals and/or disinfectants	Avoidance or minimisation of the use of cleaning chemicals and/or disinfectants that are harmful to the aquatic environment, in particular priority substances considered under the Water Framework Directive 2000/60/EC of the European Parliament and of the Council ⁽¹⁾ . When selecting the substances, hygiene and food safety requirements are taken into account.
b	Reuse of cleaning chemicals in cleaning-in-place (CIP)	Collection and reuse of cleaning chemicals in CIP. When reusing cleaning chemicals, hygiene and food safety requirements are taken into account.
c	Dry cleaning	See BAT 7e.
d	Optimised design and construction of equipment and process areas	See BAT 7j.

⁽¹⁾ Directive 2000/60/EC of the European Parliament and of the Council of 23 October 2000 establishing a framework for Community action in the field of water policy (OJ L327, 22.12.2000, p. 1).

BAT 9. In order to prevent emissions of ozone-depleting substances and of substances with a high global warming potential from cooling and freezing, BAT is to use refrigerants without ozone depletion potential and with a low global warming potential.

Description

Suitable refrigerants include water, carbon dioxide or ammonia.

17.1.6 Resource efficiency

BAT 10. In order to increase resource efficiency, BAT is to use one or a combination of the techniques given below.

	Technique	Description	Applicability
a	Anaerobic digestion	Treatment of biodegradable residues by microorganisms in the absence of oxygen, resulting in biogas and digestate. The biogas is used as a fuel, e.g. in a gas engine or in a boiler. The digestate may be used, e.g. as a soil improver.	May not be applicable due to the quantity and/or nature of the residues.
b	Use of residues	Residues are used, e.g. as animal feed.	May not be applicable due to legal requirements.
c	Separation of residues	Separation of residues, e.g. using accurately positioned splash protectors, screens, flaps, catchpots, drip trays and troughs.	Generally applicable.
d	Recovery and reuse of residues from the pasteuriser	Residues from the pasteuriser are fed back to the blending unit and are thereby reused as raw materials.	Only applicable to liquid food products.
e	Phosphorus recovery as struvite	See BAT 12g.	Only applicable to waste water streams with a high total phosphorus content (e.g. above 50 mg/l) and a significant flow.
f	Use of waste water for land spreading	After appropriate treatment, waste water is used for land spreading in order to take advantage of the nutrient content and/or to use the water.	Only applicable in the case of a proven agronomic benefit, a proven low level of contamination and no negative impact on the environment (e.g. on the soil, the groundwater and surface water). The applicability may be restricted due to the limited availability of suitable land adjacent to the installation. The applicability may be restricted by the soil and local climatic conditions (e.g. in the case of wet or frozen fields) or by legislation.

Further sector-specific techniques to reduce waste sent for disposal are given in Sections 17.3.3, 17.4.3 and 17.5.1 of these BAT conclusions.

17.1.7 Emissions to water

BAT 11. In order to prevent uncontrolled emissions to water, BAT is to provide an appropriate buffer storage capacity for waste water.

Description

The appropriate buffer storage capacity is determined by a risk assessment (taking into account the nature of the pollutant(s), the effects of these pollutants on further waste water treatment, the receiving environment, etc.).

The waste water from this buffer storage is discharged after appropriate measures are taken (e.g. monitoring, treatment, reuse).

Applicability

For existing plants, the technique may not be applicable due to lack of space and/or due to the layout of the waste water collection system.

BAT 12. In order to reduce emissions to water, BAT is to use an appropriate combination of the techniques given below.

	Technique ⁽¹⁾	Typical pollutants targeted	Applicability
<i>Preliminary, primary and general treatment</i>			
a	Equalisation	All pollutants	Generally applicable.
b	Neutralisation	Acids, alkalis	
c	Physical separation, e.g. screens, sieves, grit separators, oil/fat separators, or primary settlement tanks	Gross solids, suspended solids, oil/grease	
<i>Aerobic and/or anaerobic treatment (secondary treatment)</i>			
d	Aerobic and/or anaerobic treatment (secondary treatment), e.g. activated sludge process, aerobic lagoon, upflow anaerobic sludge blanket (UASB) process, anaerobic contact process, membrane bioreactor	Biodegradable organic compounds	Generally applicable.
<i>Nitrogen removal</i>			
e	Nitrification and/or denitrification	Total nitrogen, ammonium/ammonia	Nitrification may not be applicable in the case of high chloride concentrations (e.g. above 10 g/l). Nitrification may not be applicable when the temperature of the waste water is low (e.g. below 12 °C).
f	Partial nitrification - Anaerobic ammonium oxidation		May not be applicable when the temperature of the waste water is low.
<i>Phosphorus recovery and/or removal</i>			
g	Phosphorus recovery as struvite	Total phosphorus	Only applicable to waste water streams with a high total phosphorus content (e.g. above 50 mg/l) and a significant flow.
h	Precipitation		Generally applicable.
i	Enhanced biological phosphorus removal		
<i>Final solids removal</i>			
j	Coagulation and flocculation	Suspended solids	Generally applicable.
k	Sedimentation		
l	Filtration (e.g. sand filtration, microfiltration, ultrafiltration)		
m	Flotation		
⁽¹⁾ The descriptions of the techniques are given in Section 17.14.1.			

The BAT-associated emission levels (BAT-AELs) for emissions to water given in Table 17.1 apply to direct emissions to a receiving water body.

The BAT-AELs apply at the point where the emission leaves the installation.

Table 17.1: BAT-associated emission levels (BAT-AELs) for direct emissions to a receiving water body

Parameter	BAT-AEL ⁽¹⁾ ⁽²⁾ (daily average)
Chemical oxygen demand (COD) ⁽³⁾ ⁽⁴⁾	25–100 mg/l ⁽⁵⁾
Total suspended solids (TSS)	4–50 mg/l ⁽⁶⁾
Total nitrogen (TN)	2–20 mg/l ⁽⁷⁾ ⁽⁸⁾
Total phosphorus (TP)	0.2–2 mg/l ⁽⁹⁾

⁽¹⁾ The BAT-AELs do not apply to emissions from grain milling, green fodder processing, and the production of dry pet food and compound feed.

⁽²⁾ The BAT-AELs may not apply to the production of citric acid or yeast.

⁽³⁾ No BAT-AEL applies for biochemical oxygen demand (BOD). As an indication, the yearly average BOD₅ level in the effluent from a biological waste water treatment plant will generally be ≤ 20 mg/l.

⁽⁴⁾ The BAT-AEL for COD may be replaced by a BAT-AEL for TOC. The correlation between COD and TOC is determined on a case-by-case basis. The BAT-AEL for TOC is the preferred option because TOC monitoring does not rely on the use of very toxic compounds.

⁽⁵⁾ The upper end of the range is:

- 125 mg/l for dairies;
- 120 mg/l for fruit and vegetable installations;
- 200 mg/l for oilseed processing and vegetable oil refining installations;
- 185 mg/l for starch production installations;
- 155 mg/l for sugar manufacturing installations;

as daily averages only if the abatement efficiency is ≥ 95 % as a yearly average or as an average over the production period.

⁽⁶⁾ The lower end of the range is typically achieved when using filtration (e.g. sand filtration, microfiltration, membrane bioreactor), while the upper end of the range is typically achieved when using sedimentation only.

⁽⁷⁾ The upper end of the range is 30 mg/l as a daily average only if the abatement efficiency is ≥ 80 % as a yearly average or as an average over the production period.

⁽⁸⁾ The BAT-AEL may not apply when the temperature of the waste water is low (e.g. below 12 °C) for prolonged periods.

⁽⁹⁾ The upper end of the range is:

- 4 mg/l for dairies and starch installations producing modified and/or hydrolysed starch;
- 5 mg/l for fruit and vegetable installations;
- 10 mg/l for oilseed processing and vegetable oil refining installations carrying out soap-stock splitting;

as daily averages only if the abatement efficiency is ≥ 95 % as a yearly average or as an average over the production period.

The associated monitoring is given in BAT 4.

17.1.8 Noise

BAT 13. In order to prevent or, where that is not practicable, to reduce noise emissions, BAT is to set up, implement and regularly review a noise management plan, as part of the environmental management system (see BAT 1), that includes all of the following elements:

- a protocol containing actions and timelines;
- a protocol for conducting noise emissions monitoring;
- a protocol for response to identified noise events, e.g. complaints;
- a noise reduction programme designed to identify the source(s), to measure/estimate noise and vibration exposure, to characterise the contributions of the sources and to implement prevention and/or reduction measures.

Applicability

BAT 13 is only applicable to cases where a noise nuisance at sensitive receptors is expected and/or has been substantiated.

BAT 14. In order to prevent or, where that is not practicable, to reduce noise emissions, BAT is to use one or a combination of the techniques given below.

Technique		Description	Applicability
a	Appropriate location of equipment and buildings	Noise levels can be reduced by increasing the distance between the emitter and the receiver, by using buildings as noise screens and by relocating buildings' exits or entrances.	For existing plants, the relocation of equipment and buildings' exits or entrances may not be applicable due to lack of space and/or excessive costs.
b	Operational measures	These include: <ol style="list-style-type: none"> i. improved inspection and maintenance of equipment; ii. closing of doors and windows of enclosed areas, if possible; iii. equipment operation by experienced staff; iv. avoidance of noisy activities at night, if possible; v. provisions for noise control, e.g. during maintenance activities. 	Generally applicable.
c	Low-noise equipment	This includes low-noise compressors, pumps and fans.	
d	Noise control equipment	This includes: <ol style="list-style-type: none"> i. noise reducers; ii. insulation of equipment; iii. enclosure of noisy equipment; iv. soundproofing of buildings. 	May not be applicable to existing plants due to lack of space.
e	Noise abatement	Inserting obstacles between emitters and receivers (e.g. protection walls, embankments and buildings).	Applicable only to existing plants, as the design of new plants should make this technique unnecessary. For existing plants, the insertion of obstacles may not be applicable due to lack of space.

17.1.9 Odour

BAT 15. In order to prevent or, where that is not practicable, to reduce odour emissions, BAT is to set up, implement and regularly review an odour management plan, as part of the environmental management system (see BAT 1), that includes all of the following elements:

- A protocol containing actions and timelines.
- A protocol for conducting odour monitoring. It may be complemented by measurement/estimation of odour exposure or estimation of odour impact.
- A protocol for response to identified odour incidents, e.g. complaints.
- An odour prevention and reduction programme designed to identify the source(s); to measure/estimate odour exposure; to characterise the contributions of the sources; and to implement prevention and/or reduction measures.

Applicability

BAT 15 is only applicable to cases where an odour nuisance at sensitive receptors is expected and/or has been substantiated.

17.2 BAT conclusions for animal feed

The BAT conclusions presented in this section apply to animal feed. They apply in addition to the general BAT conclusions given in Section 17.1.

17.2.1 Energy efficiency

17.2.1.1 Compound feed/Pet food

General techniques to increase energy efficiency are given in Section 17.1.3 of these BAT conclusions. Indicative environmental performance levels are presented in the table below.

Table 17.2: Indicative environmental performance levels for specific energy consumption

Product	Unit	Specific energy consumption (yearly average)
Compound feed	MWh/tonne of products	0.01–0.10 ⁽¹⁾ ⁽²⁾ ⁽³⁾
Dry pet food		0.39–0.50
Wet pet food		0.33–0.85
⁽¹⁾ The lower end of the range can be achieved when pelleting is not applied. ⁽²⁾ The specific energy consumption level may not apply when fish and other aquatic animals are used as raw material. ⁽³⁾ The upper end of the range is 0.12 MWh/tonne of products for installations located in cold climates and/or when heat treatment is used for Salmonella decontamination.		

17.2.1.2 Green fodder

BAT 16. In order to increase energy efficiency in green fodder processing, BAT is to use an appropriate combination of the techniques specified in BAT 6 and of the techniques given below.

Technique		Description	Applicability
a	Use of predried fodder	Use of fodder that has been predried (e.g. by flat pre-wilting).	Not applicable in the case of the wet process.
b	Recycling of waste gas from the dryer	Injection of the waste gas from the cyclone into the burner of the dryer.	Generally applicable.
c	Use of waste heat for predrying	The heat of the outlet steam from the high-temperature dryers is used for predrying part or all of the green fodder.	

17.2.2 Water consumption and waste water discharge

General techniques to reduce water consumption and the volume of waste water discharged are given in Section 17.1.4 of these BAT conclusions. The indicative environmental performance level is presented in the table below.

Table 17.3: Indicative environmental performance level for specific waste water discharge

Product	Unit	Specific waste water discharge (yearly average)
Wet pet food	m ³ /tonne of products	1.3–2.4

17.2.3 Emissions to air

BAT 17. In order to reduce channelled dust emissions to air, BAT is to use one of the techniques given below.

Technique		Description	Applicability
a	Bag filter	See Section 17.14.2.	May not be applicable to the abatement of sticky dust.
b	Cyclone		Generally applicable.

Table 17.4: BAT-associated emission levels (BAT-AELs) for channelled dust emissions to air from grinding and pellet cooling in compound feed manufacture

Parameter	Specific process	Unit	BAT-AEL (average over the sampling period)	
			New plants	Existing plants
Dust	Grinding	mg/Nm ³	< 2–5	< 2–10
	Pellet cooling		< 2–20	

The associated monitoring is given in BAT 5.

17.3 BAT conclusions for brewing

The BAT conclusions presented in this section apply to brewing. They apply in addition to the general BAT conclusions given in Section 17.1.

17.3.1 Energy efficiency

BAT 18. In order to increase energy efficiency, BAT is to use an appropriate combination of the techniques specified in BAT 6 and of the techniques given below.

Technique		Description	Applicability
a	Mashing-in at higher temperatures	The mashing-in of the grain is carried out at temperatures of approximately 60 °C, which reduces the use of cold water.	May not be applicable due to the product specifications.
b	Decrease of the evaporation rate during wort boiling	The evaporation rate can be reduced from 10 % down to approximately 4 % per hour (e.g. by two-phase boiling systems, dynamic low-pressure boiling).	
c	Increase of the degree of high-gravity brewing	Production of concentrated wort, which reduces its volume and thereby saves energy.	

Table 17.5: Indicative environmental performance level for specific energy consumption

Unit	Specific energy consumption (yearly average)
MWh/hl of products	0.02–0.05

17.3.2 Water consumption and waste water discharge

General techniques to reduce water consumption and the volume of waste water discharged are given in Section 17.1.4 of these BAT conclusions. The indicative environmental performance level is presented in the table below.

Table 17.6: Indicative environmental performance level for specific waste water discharge

Unit	Specific waste water discharge (yearly average)
m ³ /hl of products	0.15–0.50

17.3.3 Waste

BAT 19. In order to reduce the quantity of waste sent for disposal, BAT is to use one or both of the techniques given below.

Technique		Description
a	Recovery and (re)use of yeast after fermentation	After fermentation, yeast is collected and can be partially reused in the fermentation process and/or may be further used for multiple purposes, e.g. as animal feed, in the pharmaceutical industry, as a food ingredient, in an anaerobic waste water treatment plant for biogas production.
b	Recovery and (re)use of natural filter material	After chemical, enzymatic or thermal treatment, natural filter material (e.g. diatomaceous earth) may be partially reused in the filtration process. Natural filter material can also be used, e.g. as a soil improver.

17.3.4 Emissions to air

BAT 20. In order to reduce channelled dust emissions to air, BAT is to use a bag filter or both a cyclone and a bag filter.

Description

See Section 17.14.2.

Table 17.7: BAT-associated emission levels (BAT-AELs) for channelled dust emissions to air from handling and processing of malt and adjuncts

Parameter	Unit	BAT-AEL (average over the sampling period)	
		New plants	Existing plants
Dust	mg/Nm ³	< 2–5	< 2–10

The associated monitoring is given in BAT 5.

17.4 BAT conclusions for dairies

The BAT conclusions presented in this section apply to dairies. They apply in addition to the general BAT conclusions given in Section 17.1.

17.4.1 Energy efficiency

BAT 21. In order to increase energy efficiency, BAT is to use an appropriate combination of the techniques specified in BAT 6 and of the techniques given below.

Technique		Description
a	Partial milk homogenisation	The cream is homogenised together with a small proportion of skimmed milk. The size of the homogeniser can be significantly reduced, leading to energy savings.
b	Energy-efficient homogeniser	The homogeniser's working pressure is reduced through optimised design and thus the associated electrical energy needed to drive the system is also reduced.
c	Use of continuous pasteurisers	Flow-through heat exchangers are used (e.g. tubular, plate and frame). The pasteurisation time is much shorter than that of batch systems.
d	Regenerative heat exchange in pasteurisation	The incoming milk is preheated by the hot milk leaving the pasteurisation section.
e	Ultra-high-temperature (UHT) processing of milk without intermediate pasteurisation	UHT milk is produced in one step from raw milk, thus avoiding the energy needed for pasteurisation.
f	Multi-stage drying in powder production	A spray-drying process is used in combination with a downstream dryer, e.g. fluidised bed dryer.
g	Precooling of ice-water	When ice-water is used, the returning ice-water is pre-cooled (e.g. with a plate heat exchanger), prior to final cooling in an accumulating ice-water tank with a coil evaporator.

Table 17.8: Indicative environmental performance levels for specific energy consumption

Main product (at least 80 % of the production)	Unit	Specific energy consumption (yearly average)
Market milk	MWh/tonne of raw materials	0.1–0.6
Cheese		0.10–0.22 ⁽¹⁾
Powder		0.2–0.5
Fermented milk		0.2–1.6
⁽¹⁾ The specific energy consumption level may not apply when raw materials other than milk are used.		

17.4.2 Water consumption and waste water discharge

General techniques to reduce water consumption and the volume of waste water discharged are given in Section 17.1.4 of these BAT conclusions. Indicative environmental performance levels are presented in the table below.

Table 17.9: Indicative environmental performance levels for specific waste water discharge

Main product (at least 80 % of the production)	Unit	Specific waste water discharge (yearly average)
Market milk	m ³ /tonne of raw materials	0.3–3.0
Cheese		0.75–2.5
Powder		1.2–2.7

17.4.3 Waste

BAT 22. In order to reduce the quantity of waste sent for disposal, BAT is to use one or a combination of the techniques given below.

Technique		Description
<i>Techniques related to the use of centrifuges</i>		
a	Optimised operation of centrifuges	Operation of centrifuges according to their specifications to minimise the rejection of product.
<i>Techniques related to butter production</i>		
b	Rinsing of the cream heater with skimmed milk or water	Rinsing of the cream heater with skimmed milk or water which is then recovered and reused, before the cleaning operations.
<i>Techniques related to ice cream production</i>		
c	Continuous freezing of ice cream	Continuous freezing of ice cream using optimised start-up procedures and control loops that reduce the frequency of stoppages.
<i>Techniques related to cheese production</i>		
d	Minimisation of the generation of acid whey	Whey from the manufacture of acid-type cheeses (e.g. cottage cheese, quark and mozzarella) is processed as quickly as possible to reduce the formation of lactic acid.
e	Recovery and use of whey	Whey is recovered (if necessary using techniques such as evaporation or membrane filtration) and used, e.g. to produce whey powder, demineralised whey powder, whey protein concentrates or lactose. Whey and whey concentrates can also be used as animal feed or as a carbon source in a biogas plant.

17.4.4 Emissions to air

BAT 23. In order to reduce channelled dust emissions to air from drying, BAT is to use one or a combination of the techniques given below.

Technique		Description	Applicability
a	Bag filter	See Section 17.14.2.	May not be applicable to the abatement of sticky dust.
b	Cyclone		Generally applicable.
c	Wet scrubber		

Table 17.10: BAT-associated emission level (BAT-AEL) for channelled dust emissions to air from drying

Parameter	Unit	BAT-AEL (average over the sampling period)
Dust	mg/Nm ³	< 2–10 ⁽¹⁾
⁽¹⁾ The upper end of the range is 20 mg/Nm ³ for drying of demineralised whey powder, casein and lactose.		

The associated monitoring is given in BAT 5.

17.5 BAT conclusions for ethanol production

The BAT conclusion presented in this section applies to ethanol production. It applies in addition to the general BAT conclusions given in Section 17.1.

17.5.1 Waste

BAT 24. In order to reduce the quantity of waste sent for disposal, BAT is to recover and (re)use yeast after fermentation.

Description

See BAT 19a. The yeast may not be recovered when the stillage is used as animal feed.

17.6 BAT conclusions for fish and shellfish processing

The BAT conclusions presented in this section apply to fish and shellfish processing. They apply in addition to the general BAT conclusions given in Section 17.1.

17.6.1 Water consumption and waste water discharge

BAT 25. In order to reduce water consumption and the volume of waste water discharged, BAT is to use an appropriate combination of the techniques specified in BAT 7 and of the techniques given below.

Technique		Description
a	Removal of fat and viscera by vacuum	Use of vacuum suction instead of water to remove fat and viscera from the fish.
b	Dry transport of fat, viscera, skin and fillets	Use of conveyors instead of water.

17.6.2 Emissions to air

BAT 26. In order to reduce channelled emissions of organic compounds to air from fish smoking, BAT is to use one or a combination of the techniques given below.

Technique		Description
a	Biofilter	The waste gas stream is passed through a bed of organic material (such as peat, heather, root, tree bark, compost, softwood and different kinds of combinations) or some inert material (such as clay, activated carbon, and polyurethane), where organic (and some inorganic) components are transformed by naturally occurring microorganisms into carbon dioxide, water, other metabolites and biomass.
b	Thermal oxidation	See Section 17.14.2.
c	Non-thermal plasma treatment	
d	Wet scrubber	See Section 17.14.2. An electrostatic precipitator is commonly used as a pre-treatment step.
e	Use of purified smoke	Smoke generated from purified primary smoke condensates is used to smoke the product in a smoke chamber.

Table 17.11: BAT-associated emission level (BAT-AEL) for channelled TVOC emissions to air from a smoke chamber

Parameter	Unit	BAT-AEL (average over the sampling period)
TVOC	mg/Nm ³	15–50 ⁽¹⁾ ⁽²⁾
⁽¹⁾ The lower end of the range is typically achieved when using thermal oxidation. ⁽²⁾ The BAT-AEL does not apply when the TVOC emission load is below 500 g/h.		

The associated monitoring is given in BAT 5.

17.7 BAT conclusions for the fruit and vegetable sector

The BAT conclusions presented in this section apply to the fruit and vegetable sector. They apply in addition to the general BAT conclusions given in Section 17.1.

17.7.1 Energy efficiency

BAT 27. In order to increase energy efficiency, BAT is to use an appropriate combination of the techniques specified in BAT 6 and to cool fruit and vegetables before deep freezing.

Description

The temperature of the fruit and vegetables is lowered to around 4 °C before they enter the freezing tunnel by bringing them into direct or indirect contact with cold water or cooling air. Water can be removed from the food and then collected for reuse in the cooling process.

Table 17.12: Indicative environmental performance levels for specific energy consumption

Specific process	Unit	Specific energy consumption (yearly average)
Potato processing (excluding starch production)	MWh/tonne of products	1.0–2.1 ⁽¹⁾
Tomato processing		0.15–2.4 ⁽²⁾ ⁽³⁾
⁽¹⁾ The specific energy consumption level may not apply to the production of potato flakes and powder. ⁽²⁾ The lower end of the range is typically associated with the production of peeled tomatoes. ⁽³⁾ The upper end of the range is typically associated with the production of tomato powder or concentrate.		

17.7.2 Water consumption and waste water discharge

General techniques to reduce water consumption and the volume of waste water discharged are given in Section 17.1.4 of these BAT conclusions. Indicative environmental performance levels are presented in the table below.

Table 17.13: Indicative environmental performance levels for specific waste water discharge

Specific process	Unit	Specific waste water discharge (yearly average)
Potato processing (excluding starch production)	m ³ /tonne of products	4.0–6.0 ⁽¹⁾
Tomato processing when water recycling is possible		8.0–10.0 ⁽²⁾
⁽¹⁾ The specific waste water discharge level may not apply to the production of potato flakes and powder. ⁽²⁾ The specific waste water discharge level may not apply to the production of tomato powder.		

17.8 BAT conclusions for grain milling

The BAT conclusions presented in this section apply to grain milling. They apply in addition to the general BAT conclusions given in Section 17.1.

17.8.1 Energy efficiency

General techniques to increase energy efficiency are given in Section 17.1.3 of these BAT conclusions. The indicative environmental performance level is presented in the table below.

Table 17.14: Indicative environmental performance level for specific energy consumption

Unit	Specific energy consumption (yearly average)
MWh/tonne of products	0.05–0.13

17.8.2 Emissions to air

BAT 28. In order to reduce channelled dust emissions to air, BAT is to use a bag filter.

Description

See Section 17.14.2.

Table 17.15: BAT-associated emission level (BAT-AEL) for channelled dust emissions to air from grain milling

Parameter	Unit	BAT-AEL (average over the sampling period)
Dust	mg/Nm ³	< 2–5

The associated monitoring is given in BAT 5.

17.9 BAT conclusions for meat processing

The BAT conclusions presented in this section apply to meat processing. They apply in addition to the general BAT conclusions given in Section 17.1.

17.9.1 Energy efficiency

General techniques to increase energy efficiency are given in Section 17.1.3 of these BAT conclusions. The indicative environmental performance level is presented in the table below.

Table 17.16: Indicative environmental performance level for specific energy consumption

Unit	Specific energy consumption (yearly average)
MWh/tonne of raw materials	0.25–2.6 ⁽¹⁾ ⁽²⁾
⁽¹⁾ The specific energy consumption level does not apply to the production of ready meals and soups. ⁽²⁾ The upper end of the range may not apply in the case of a high percentage of cooked products.	

17.9.2 Water consumption and waste water discharge

General techniques to reduce water consumption and the volume of waste water discharged are given in Section 17.1.4 of these BAT conclusions. The indicative environmental performance level is presented in the table below.

Table 17.17: Indicative environmental performance level for specific waste water discharge

Unit	Specific waste water discharge (yearly average)
m ³ /tonne of raw materials	1.5–8.0 ⁽¹⁾
⁽¹⁾ The specific waste water discharge level does not apply to processes using direct water cooling and to the production of ready meals and soups.	

17.9.3 Emissions to air

BAT 29. In order to reduce channelled emissions of organic compounds to air from meat smoking, BAT is to use one or a combination of the techniques given below.

Technique		Description
a	Adsorption	Organic compounds are removed from a waste gas stream by retention on a solid surface (typically activated carbon).
b	Thermal oxidation	See Section 17.14.2.
c	Wet scrubber	See Section 17.14.2. An electrostatic precipitator is commonly used as a pretreatment step.
d	Use of purified smoke	Smoke generated from purified primary smoke condensates is used to smoke the product in a smoke chamber.

Table 17.18: BAT-associated emission level (BAT-AEL) for channelled TVOC emissions to air from a smoke chamber

Parameter	Unit	BAT-AEL (average over the sampling period)
TVOC	mg/Nm ³	3–50 ⁽¹⁾ ⁽²⁾
⁽¹⁾ The lower end of the range is typically achieved when using adsorption or thermal oxidation.		
⁽²⁾ The BAT-AEL does not apply when the TVOC emission load is below 500 g/h.		

The associated monitoring is given in BAT 5.

17.10 BAT conclusions for oilseed processing and vegetable oil refining

The BAT conclusions presented in this section apply to oilseed processing and vegetable oil refining. They apply in addition to the general BAT conclusions given in Section 17.1.

17.10.1 Energy efficiency

BAT 30. In order to increase energy efficiency, BAT is to use an appropriate combination of the techniques specified in BAT 6 and to generate an auxiliary vacuum.

Description

The auxiliary vacuum used for oil drying, oil degassing or minimisation of oil oxidation is generated by pumps, steam injectors, etc. The vacuum reduces the amount of thermal energy needed for these process steps.

Table 17.19: Indicative environmental performance levels for specific energy consumption

Specific process	Unit	Specific energy consumption (yearly average)
Integrated crushing and refining of rapeseeds and/or sunflower seeds	MWh/tonne of oil produced	0.45–1.05
Integrated crushing and refining of soybeans		0.65–1.65
Stand-alone refining		0.1–0.45

17.10.2 Water consumption and waste water discharge

General techniques to reduce water consumption and the volume of waste water discharged are given in Section 17.1.4 of these BAT conclusions. Indicative environmental performance levels are presented in the table below.

Table 17.20: Indicative environmental performance levels for specific waste water discharge

Specific process	Unit	Specific waste water discharge (yearly average)
Integrated crushing and refining of rapeseeds and/or sunflower seeds	m ³ /tonne of oil produced	0.15–0.75
Integrated crushing and refining of soybeans		0.8–1.9
Stand-alone refining		0.15–0.9

17.10.3 Emissions to air

BAT 31. In order to reduce channelled dust emissions to air, BAT is to use one or a combination of the techniques given below.

Technique		Description	Applicability
a	Bag filter	See Section 17.14.2.	May not be applicable to the abatement of sticky dust.
b	Cyclone		Generally applicable.
c	Wet scrubber		

Table 17.21: BAT-associated emission levels (BAT-AELs) for channelled dust emissions to air from handling and preparation of seeds as well as drying and cooling of meal

Parameter	Unit	BAT-AEL (average over the sampling period)	
		New plants	Existing plants
Dust	mg/Nm ³	< 2–5 ⁽¹⁾	< 2–10 ⁽¹⁾

⁽¹⁾ The upper end of the range is 20 mg/Nm³ for drying and cooling of meal.

The associated monitoring is given in BAT 5.

17.10.4 Hexane losses

BAT 32. In order to reduce the hexane losses from oilseed processing and refining, BAT is to use all of the techniques given below.

Technique		Description
a	Countercurrent flow of meal and steam in the desolventiser-toaster	Hexane is removed from the hexane-laden meal in a desolventiser-toaster, involving a countercurrent flow of steam and meal.
b	Evaporation from the oil/hexane mixture	Hexane is removed from the oil/hexane mixture using evaporators. The vapours from the desolventiser-toaster (steam/hexane mixture) are used to provide thermal energy in the first stage of the evaporation.
c	Condensation in combination with a mineral oil wet scrubber	Hexane vapours are cooled to below their dew point so that they condense. Uncondensed hexane is absorbed in a scrubber using mineral oil as a scrubbing liquid for subsequent recovery.
d	Gravitational phase separation in combination with distillation	Undissolved hexane is separated from the aqueous phase by means of a gravitational phase separator. Any residual hexane is distilled off by heating the aqueous phase to approximately 80–95 °C.

Table 17.22: BAT-associated emission levels (BAT-AELs) for hexane losses from oilseed processing and refining

Parameter	Type of seeds or beans processed	Unit	BAT-AEL (yearly average)
Hexane losses	Soybeans	kg/tonne of seeds or beans processed	0.3–0.55
	Rapeseeds and sunflower seeds		0.2–0.7

17.11 BAT conclusions for soft drinks and nectar/juice made from processed fruit and vegetables

The BAT conclusions presented in this section apply to soft drinks and nectar/juice made from processed fruit and vegetables. They apply in addition to the general BAT conclusions given in Section 17.1.

17.11.1 Energy efficiency

BAT 33. In order to increase energy efficiency, BAT is to use an appropriate combination of the techniques specified in BAT 6 and of the techniques given below.

Technique		Description	Applicability
a	Single pasteuriser for nectar/juice production	Use of one pasteuriser for both the juice and the pulp instead of using two separate pasteurisers.	May not be applicable due to the pulp particle size.
b	Hydraulic sugar transportation	Sugar is transported to the production process with water. As some of the sugar is already dissolved during the transportation, less energy is needed in the process for dissolving sugar.	Generally applicable
c	Energy-efficient homogeniser for nectar/juice production	See BAT 21b.	

Table 17.23: Indicative environmental performance level for specific energy consumption

Unit	Specific energy consumption (yearly average)
MWh/hl of products	0.01–0.035

17.11.2 Water consumption and waste water discharge

General techniques to reduce water consumption and the volume of waste water discharged are given in Section 17.1.4 of these BAT conclusions. The indicative environmental performance level is presented in the table below.

Table 17.24: Indicative environmental performance level for specific waste water discharge

Unit	Specific waste water discharge (yearly average)
m ³ /hl of products	0.08–0.20

17.12 BAT conclusions for starch production

The BAT conclusions presented in this section apply to starch production. They apply in addition to the general BAT conclusions given in Section 17.1.

17.12.1 Energy efficiency

General techniques to increase energy efficiency are given in Section 17.1.3 of these BAT conclusions. Indicative environmental performance levels are presented in the table below.

Table 17.25: Indicative environmental performance levels for specific energy consumption

Specific process	Unit	Specific energy consumption (yearly average)
Potato processing for the production of native starch only	MWh/tonne of raw materials ⁽¹⁾	0.08–0.14
Maize and/or wheat processing for the production of native starch in combination with modified and/or hydrolysed starch		0.65–1.25 ⁽²⁾
⁽¹⁾ The amount of raw materials refers to gross tonnage. ⁽²⁾ The specific energy consumption level does not apply to the production of polyols.		

17.12.2 Water consumption and waste water discharge

General techniques to reduce water consumption and the volume of waste water discharged are given in Section 17.1.4 of these BAT conclusions. Indicative environmental performance levels are presented in the table below.

Table 17.26: Indicative environmental performance levels for specific waste water discharge

Specific process	Unit	Specific waste water discharge (yearly average)
Potato processing for the production of native starch only	m ³ /tonne of raw materials ⁽¹⁾	0.4–1.15
Maize and/or wheat processing for the production of native starch in combination with modified and/or hydrolysed starch		1.1–3.9 ⁽²⁾
⁽¹⁾ The amount of raw materials refers to gross tonnage. ⁽²⁾ The specific waste water discharge level does not apply to the production of polyols.		

17.12.3 Emissions to air

BAT 34. In order to reduce channelled dust emissions to air from starch, protein and fibre drying, BAT is to use one or a combination of the techniques given below.

Technique		Description	Applicability
a	Bag filter	See Section 17.14.2.	May not be applicable to the abatement of sticky dust.
b	Cyclone		Generally applicable.
c	Wet scrubber		

Table 17.27: BAT-associated emission levels (BAT-AELs) for channelled dust emissions to air from starch, protein and fibre drying

Parameter	Unit	BAT-AEL (average over the sampling period)	
		New plants	Existing plants
Dust	mg/Nm ³	< 2–5 ⁽¹⁾	< 2–10 ⁽¹⁾

⁽¹⁾ When a bag filter is not applicable, the upper end of the range is 20 mg/Nm³.

The associated monitoring is given in BAT 5.

17.13 BAT conclusions for sugar manufacturing

The BAT conclusions presented in this section apply to sugar manufacturing. They apply in addition to the general BAT conclusions given in Section 17.1.

17.13.1 Energy efficiency

BAT 35. In order to increase the energy efficiency, BAT is to use an appropriate combination of the techniques specified in BAT 6 and one or a combination of the techniques given below.

Technique		Description	Applicability
a	Pressing of beet pulp	The beet pulp is pressed to a dry matter content of typically 25–32 wt-%.	Generally applicable.
b	Indirect drying (steam drying) of beet pulp	Drying of beet pulp by the use of superheated steam.	May not be applicable to existing plants due to the need for a complete reconstruction of the energy facilities.
c	Solar drying of beet pulp	Use of solar energy to dry beet pulp.	May not be applicable due to local climatic conditions and/or lack of space.
d	Recycling of hot gases	Recycling of hot gases (e.g. waste gases from the dryer, boiler or combined heat and power plant).	Generally applicable.
e	Low-temperature (pre)drying of beet pulp	Direct (pre)drying of beet pulp using drying gas, e.g. air or hot gas.	

Table 17.28: Indicative environmental performance level for specific energy consumption

Specific process	Unit	Specific energy consumption (yearly average)
Sugar beet processing	MWh/tonne of beets	0.15–0.40 ⁽¹⁾
⁽¹⁾ The upper end of the range may include the energy consumption of the lime kilns and dryers.		

17.13.2 Water consumption and waste water discharge

General techniques to reduce water consumption and the volume of waste water discharged are given in Section 17.1.4 of these BAT conclusions. The indicative environmental performance level is presented in the table below.

Table 17.29: Indicative environmental performance level for specific waste water discharge

Specific process	Unit	Specific waste water discharge (yearly average)
Sugar beet processing	m ³ /tonne of beets	0.5–1.0

17.13.3 Emissions to air

BAT 36. In order to prevent or reduce channelled dust emissions to air from beet pulp drying, BAT is to use one or a combination of the techniques given below.

Technique		Description	Applicability
a	Use of gaseous fuels	See Section 17.14.2.	May not be applicable due to the constraints associated with the availability of gaseous fuels.
b	Cyclone		Generally applicable.
c	Wet scrubber		
d	Indirect drying (steam drying) of beet pulp	See BAT 35b.	May not be applicable to existing plants due to the need for a complete reconstruction of the energy facilities.
e	Solar drying of beet pulp	See BAT 35c.	May not be applicable due to local climatic conditions and/or lack of space.
f	Low-temperature (pre)drying of beet pulp	See BAT 35e.	Generally applicable.

Table 17.30: BAT-associated emission level (BAT-AEL) for channelled dust emissions to air from beet pulp drying in the case of high-temperature drying (above 500 °C)

Parameter	Unit	BAT-AEL (average over the sampling period)	Reference oxygen level (O _R)	Reference gas condition
Dust	mg/Nm ³	5–100	16 vol-%	No correction for water content

The associated monitoring is given in BAT 5.

BAT 37. In order to reduce channelled SO_x emissions to air from high-temperature beet pulp drying (above 500 °C), BAT is to use one or a combination of the techniques given below.

Technique		Description	Applicability
a	Use of natural gas	—	May not be applicable due to the constraints associated with the availability of natural gas.
b	Wet scrubber	See Section 14.2.	Generally applicable.
c	Use of fuels with low sulphur content	—	Only applicable when natural gas is not available.

Table 17.31: BAT-associated emission level (BAT-AEL) for channelled SO_x emissions to air from beet pulp drying in the case of high-temperature drying (above 500 °C) when natural gas is not used

Parameter	Unit	BAT-AEL (average over the sampling period) ⁽¹⁾	Reference oxygen level (O _R)	Reference gas condition
SO _x	mg/Nm ³	30–100	16 vol-%	No correction for water content
⁽¹⁾ When using exclusively biomass as a fuel, emission levels are expected to be at the lower end of the range.				

The associated monitoring is given in BAT 5.

17.14 Description of techniques

17.14.1 Emissions to water

Technique	Description
Activated sludge process	A biological process in which the microorganisms are maintained in suspension in the waste water and the whole mixture is mechanically aerated. The activated sludge mixture is sent to a separation facility from where the sludge is recycled to the aeration tank.
Aerobic lagoon	Shallow earthen basins for the biological treatment of waste water, the content of which is periodically mixed to allow oxygen to enter the liquid through atmospheric diffusion.
Anaerobic contact process	An anaerobic process in which waste water is mixed with recycled sludge and then digested in a sealed reactor. The water/sludge mixture is separated externally.
Precipitation	The conversion of dissolved pollutants into insoluble compounds by adding chemical precipitants. The solid precipitates formed are subsequently separated by sedimentation, air flotation, or filtration. Multivalent metal ions (e.g. calcium, aluminium, iron) are used for phosphorus precipitation.
Coagulation and flocculation	Coagulation and flocculation are used to separate suspended solids from waste water and are often carried out in successive steps. Coagulation is carried out by adding coagulants with charges opposite to those of the suspended solids. Flocculation is carried out by adding polymers, so that collisions of microfloc particles cause them to bond to produce larger flocs.
Equalisation	Balancing of flows and pollutant loads by using tanks or other management techniques.
Enhanced biological phosphorus removal	A combination of aerobic and anaerobic treatment to selectively enrich polyphosphate-accumulating microorganisms in the bacterial community within the activated sludge. These microorganisms take up more phosphorus than is required for normal growth.
Filtration	The separation of solids from waste water by passing it through a porous medium, e.g. sand filtration, microfiltration and ultrafiltration.
Flotation	The separation of solid or liquid particles from waste water by attaching them to fine gas bubbles, usually air. The buoyant particles accumulate at the water surface and are collected with skimmers.
Membrane bioreactor	A combination of activated sludge treatment and membrane filtration. Two variants are used: a) an external recirculation loop between the activated sludge tank and the membrane module; and b) immersion of the membrane module in the aerated activated sludge tank, where the effluent is filtered through a hollow fibre membrane, with the biomass remaining in the tank.
Neutralisation	The adjustment of the pH of waste water to a neutral level (approximately 7) by the addition of chemicals. Sodium hydroxide (NaOH) or calcium hydroxide (Ca(OH) ₂) is generally used to increase the pH, whereas sulphuric acid (H ₂ SO ₄), hydrochloric acid (HCl) or carbon dioxide (CO ₂) is generally used to decrease the pH. The precipitation of some substances may occur during neutralisation.
Nitrification and/or denitrification	A two-step process that is typically incorporated into biological waste water treatment plants. The first step is the aerobic nitrification where microorganisms oxidise ammonium (NH ₄ ⁺) to the intermediate nitrite (NO ₂ ⁻), which is then further oxidised to nitrate (NO ₃ ⁻). In the subsequent anoxic denitrification step, microorganisms chemically reduce nitrate to nitrogen gas.
Partial nitrification - Anaerobic ammonium oxidation	A biological process that converts ammonium and nitrite into nitrogen gas under anaerobic conditions. In waste water treatment, anaerobic ammonium oxidation is preceded by a partial nitrification (i.e. nitritation) that converts about half of the ammonium (NH ₄ ⁺) into nitrite (NO ₂ ⁻).

Technique	Description
Phosphorus recovery as struvite	Phosphorus is recovered by precipitation in the form of struvite (magnesium ammonium phosphate).
Sedimentation	The separation of suspended particles by gravitational settling.
Upflow anaerobic sludge blanket (UASB) process	An anaerobic process in which waste water is introduced at the bottom of the reactor from where it flows upward through a sludge blanket composed of biologically formed granules or particles. The waste water phase passes into a settling chamber where the solid content is separated; the gases are collected in domes at the top of the reactor.

17.14.2 Emissions to air

Technique	Description
Bag filter	Bag filters, often referred to as fabric filters, are constructed from porous woven or felted fabric through which gases are passed to remove particles. The use of a bag filter requires the selection of a fabric suitable for the characteristics of the waste gas and the maximum operating temperature.
Cyclone	Dust control system based on centrifugal force, whereby heavier particles are separated from the carrier gas.
Non-thermal plasma treatment	Abatement technique based on creating a plasma (i.e. an ionised gas consisting of positive ions and free electrons in proportions resulting in more or less no overall electric charge) in the waste gas by using a strong electrical field. The plasma oxidises organic and inorganic compounds.
Thermal oxidation	The oxidation of combustible gases and odorants in a waste gas stream by heating the mixture of contaminants with air or oxygen to above its auto-ignition point in a combustion chamber and maintaining it at a high temperature long enough to complete its combustion to carbon dioxide and water.
Use of gaseous fuels	Switching from the combustion of a solid fuel (e.g. coal) to the combustion of a gaseous fuel (e.g. natural gas, biogas) that is less harmful in terms of emissions (e.g. low sulphur content, low ash content or better ash quality).
Wet scrubber	The removal of gaseous or particulate pollutants from a gas stream via mass transfer to a liquid solvent, often water or an aqueous solution. It may involve a chemical reaction (e.g. in an acid or alkaline scrubber). In some cases, the compounds may be recovered from the solvent.

18 CONCLUDING REMARKS AND RECOMMENDATIONS FOR FUTURE WORK

Timing of the review process

The key milestones of the review process are summarised in Table 18.1 below.

Table 18.1: Key milestones of the FDM review process

Key milestone	Date
Reactivation of the TWG	16 December 2013
Call for initial positions	16 April 2014
Kick-off meeting	27 to 30 October 2014
Drawing up of questionnaires	December 2014 to April 2015
Information collection	May 2015 to September 2015
Draft 1 of the revised FDM BREF	31 January 2017
End of commenting period on Draft 1 (1 963 comments received)	21 April 2017
Final TWG meeting	14 to 18 May 2018

During the BREF review process, a total of 19 food, drink and milk plants were visited in France, Denmark, Spain, Finland, Belgium and the Netherlands between 2014 and 2017.

In addition, the following events were organised to improve the exchange of information:

- a webinar in December 2014 for the questionnaire development;
- a workshop in March 2015 to finalise the questionnaire;
- a webinar in June 2016 on the data collected via the questionnaires;
- a workshop in October 2017 on the data assessment.

Sources of information and information gaps

The main sources of information for the review process were:

- scientific and technical literature;
- 353 filled-in questionnaires from operators of food, drink and milk plants for the various processes;
- additional information from the TWG members;
- 1 963 comments on Draft 1 of the revised BREF;
- information gathered from site visits;
- outcomes of the workshops and of the webinars mentioned above;

In total, approximately 240 documents are referenced in the revised FDM BREF.

Degree of consensus reached during the information exchange

At the final TWG meeting in May 2018, a high degree of consensus was reached on most of the BAT conclusions. However, 19 split views were expressed fulfilling the conditions set out in Section 4.6.2.3.2 of Commission Implementing Decision 2012/119/EU. They are summarised in Table 18.2 below.

Table 18.2: Split views

BAT conclusion	Split view	View expressed by	Alternative proposed level (if any)
<i>General Considerations and sectorial BAT conclusions</i>	<i>Change the indicative levels for specific waste water discharge to BAT-associated environmental performance levels (BAT-AEPLs) for specific waste water discharge</i>	EEB	NA
	<i>Change the indicative levels for specific energy consumption to BAT-associated energy efficiency levels (BAT-AEELs)</i>		
BAT 4	<i>Add monitoring provisions for indirect discharges of COD, TN, TOC, TP, TSS and BOD_n</i>	FR, SE, EEB	NA
NA	<i>Add a BAT conclusion on the use of refrigerants without ozone depletion potential and with low global warming potential</i>	AT, DE, SE, EEB	NA
Table 17.1	<i>Modify footnote 5 as follows: "The upper end of the range may be higher, if the abatement efficiency is $\geq 80\%$ as a yearly average."</i>	AT	NA
	<i>Decrease the upper end of the BAT-associated emission level (BAT-AEL) for direct emissions to a receiving water body in the case of emissions to a receiving water body in the case of TP emissions from dairies, fruit and vegetables installations and oilseed processing and vegetable oil refining installations carrying out soap-stock splitting</i>	FI	3 mg/l
	<i>Set a unique BAT-AEL range for TP for all sectors, and delete all footnotes</i>	EEB	0-2 mg/l
	<i>Increase the upper end of the BAT-associated emission level (BAT-AEL) for direct emissions to a receiving water body in the case of TP emissions from dairies</i>	IT	7 mg/l
Table 17.4	<i>Increase the upper end of the BAT-associated emission level (BAT-AEL) for channelled dust emissions to air from grinding in compound feed manufacture for new plants</i>	DE, DK, FR, FEFAC	10 mg/Nm ³
Table 17.4	<i>Increase the upper end of the BAT-associated emission level (BAT-AEL) for channelled dust emissions to air from pellet cooling for existing plants</i>	DK, COPA-COGECA	40 mg/Nm ³
Table 17.7	<i>Increase the upper end of the BAT-associated emission level (BAT-AEL) for channelled dust emissions to air from handling and processing of malt and adjuncts for new plants</i>	DE, DK, FR, FDE	10 mg/Nm ³
Table 17.8	<i>Add an indicative environmental performance level for waste water discharge for market milk installations producing yoghurt and processed cheese</i>	IT	4.5 m ³ /tonne of raw materials when producing yoghurt and processed cheese

Table 17.10	<i>Increase the upper end of the BAT-associated emission level (BAT-AEL) for channelled dust emissions to air from drying in dairies for existing plants</i>	FI	20 mg/Nm ³
Table 17.15	<i>Increase the upper end of the BAT-associated emission level (BAT-AEL) for channelled dust emissions to air from grain milling for existing plants</i>	FI	20 mg/Nm ³
Table 17.15	<i>Increase the upper end of the BAT-associated emission level (BAT-AEL) for channelled dust emissions to air from grain milling</i>	DE, FR	10 mg/Nm ³
Table 17.20	<i>Add an indicative environmental performance level for waste water discharge for speciality oils and fats refineries processing crude and/or refined oils for specific functional or nutritional applications</i>	IT	2 m ³ /tonne of oil produced for speciality oils and fats refineries processing crude and/or refined oils for specific functional or nutritional applications
Table 17.21	<i>Increase the upper end of the BAT-associated emission level (BAT-AEL) for channelled dust emissions to air from handling and preparation of seeds for new plants</i>	DE, DK, FR	10 mg/Nm ³
Table 17.27	<i>Increase the upper end of the BAT-associated emission level (BAT-AEL) for channelled dust emissions to air from starch, protein and fibre drying for new plants</i>	DE, DK, FR, FEDIOL	10 mg/Nm ³
Table 17.31	<i>Decrease the upper end of the BAT-AEL for channelled SO_x emissions to air from beet pulp drying in the case of high-temperature drying (above 500 °C) when natural gas is not used</i>	EEB	70 mg/Nm ³

Consultation of the Forum and subsequent formal adoption procedure of the BAT Conclusions

In accordance with Article 13(3) of the Directive the forum gave its opinion on the draft Best Available Techniques (BAT) reference document for the Food, Drink and Milk industries as presented at its meeting of 27 November 2018.

1. The forum welcomed the draft Best Available Techniques (BAT) reference document for the Food, Drink and Milk industries as presented by the Commission.
2. The forum acknowledged the discussions held at its meeting of 27 November 2018 and agreed that the changes to the draft Best Available Techniques (BAT) reference document for the Food, Drink and Milk industries, as proposed in Annex A, should be included in the final document.
3. The forum reaffirmed the comments in Annex B as representing the views of certain members of the forum, but on which no consensus exists within the forum to include them in the final document.

Subsequently, the Commission took the opinion of the IED Article 13 Forum into account when preparing the draft Commission Implementing Decision establishing best available techniques (BAT) conclusions for Food, Drink and Milk Industries. The IED Article 75 Committee, at its meeting of 8 April 2019, gave a positive opinion on this draft Commission Implementing Decision.

Subsequently, the Commission Implementing Decision (EU) 2019/2031 establishing best available techniques (BAT) conclusions for Food, Drink and Milk industries was adopted on 12 November 2019 and published in the Official Journal of the European Union (OJ L 313, 4.12.2019, p. 60).

Recommendations for future work

The information exchange revealed a number of issues that should be addressed during the next (second) review of the FDM BREF. These issues include the following:

- Collection of information on on-site combustion plants with a rated thermal input of less than 50 MW_{th} and which generate hot gases that are not used for direct contact heating, drying or any other treatment of objects or materials should be considered during the next review of the FDM BREF, while taking into account the information exchange foreseen under Directive (EU) 2015/2193.
- The first review of the FDM BREF (2014-2019) collected data related to emissions to water (TSS, COD, TOC, TN and TP) expressed in specific loads. However, it was not possible to derive a BAT-AEL expressed as specific loads due to: 1) BAT-AELs expressed as concentrations and BAT-AEPLs for waste water discharge were sufficient from an environmental point of view; 2) the confidentiality of the data necessary to calculate the specific loads, as the yearly production and the waste water flow were considered confidential by the TWG; 3) the difficulties to associate the specific loads with the performance of process-integrated techniques; 4) the lack of specific load data for some FDM sectors and/or products.
- Clarify the boundaries of the installation related to energy consumption (e.g. for sugar manufacturing, brewing or for oilseed processing and vegetable oil refining).
- Collect information on conversion factors between different forms of energy.
- Collect information on PM_{2.5}/PM₁₀ emissions from FDM sectors.
- Collect information on emissions from oilseed processing and vegetable oil refining installations performing soap-stock splitting.
- Collect information on the impact of the abatement of SO_x emissions to air on the waste water generation.
- Consider the addition of more details to the odour management plan.
- Collect information on dust emissions from pet food manufacturing.
- Collect information on emissions from fish smoke kilns.
- Collect information on emissions of TVOC and other compounds (e.g. PAHs) from meat smoke kilns as well as on the use of purified smoke.
- Collect information on techniques to reduce channelled TVOC emissions from oilseed processing and vegetable oil refining.
- Collect information on the influence of the physical state of the starch on the energy consumption.
- Collect information on the effect of hot gas recirculation on the SO_x emission levels from high-temperature beet pulp drying.

Suggested topics for future R&D work

The Commission is launching and supporting, through its Research and Technological Development programmes, a series of projects dealing with clean technologies, emerging effluent treatment and recycling technologies and management strategies. Potentially, these projects could provide a useful contribution to future BREF reviews. Readers are therefore invited to inform the European IPPC Bureau of any research results which are relevant to the scope of this document (see also the fifth section of the Preface of this document).

19 ANNEXES

19.1 ANNEX I - Installations that participated in the FDM data collection

Table 19.1: List of installations that participated in the FDM data collection

Installation code	Installation name	Company name	Member State	Town	Main FDM sector	Raw materials	Products
#001	Mars Austria, Bruck/Leitha	Mars Austria OG	Austria	2460 Bruck an der Leitha	Animal feed	Frozen meat	Pet food
#002	Stieglbrauere zu Salzburg	Stieglbrauerei zu Salzburg GmbH	Austria	5017 Salzburg	Brewing	Water, malt, hops and yeast	Beer (bottles, cans and barrels)
#003	Berglandmilch Wörgl	Berglandmilch reg.Gen.m.b.H.	Austria	6300 Wörgl	Dairies	Milk, whey, sugar, fruit preparations	Drinking milk, several drinks, cheese, butter
#004	Berglandmilch Aschbach-Markt	Berglandmilch reg.Gen.m.b.H.	Austria	3361 Aschbach-Markt	Dairies	Milk, cream, sugar, fruit preparations, protein powder	Butter, curd cheese, drinking milk, sour milk, yoghurt, cream, fruit yoghurt, desserts, mixed milk beverages, cheese
#005	Kärntnermilch, Spittal/Drau	Kärntnermilch reg GenmbH	Austria	9800 Spittal/Drau	Dairies	Mainly milk	Drinking milk, sour milk drinks, yoghurt, fruit yoghurt, whey drinks, butter and different types of semi-soft and hard cheese
#006	Gmundner Molkerei, Gmunden	Gmundner Molkerei reg.Gen.m.b.H.	Austria	4810 Gmunden	Dairies	Mainly milk	Milk, long-lasting milk, sour cream, butter, yoghurt and cheese, etc.
#007	Rauch, Nüziders	Rauch Fruchtsäfte GmbH & Co	Austria	6714 Nüziders	Soft drinks and nectar/juice made from fruit/vegetable	Water (Nüziders is a filling site), fruit juice concentrate	Fruit and other soft drinks
#008	Spitz, Attnang-Puchheim	S.Spitz GmbH	Austria	4800 Attnang-Puchheim	Soft drinks and nectar/juice made from fruit/vegetable	Water, fruit concentrates and mixtures, sugar, flour, cacao, hazelnuts	Water and soft drinks waffles, cake, roulades, toast, mustard, ketchup, jam, mayonnaise, alcoholic drinks

Installation code	Installation name	Company name	Member State	Town	Main FDM sector	Raw materials	Products
#009	Betriebsstätte Tann, Förderlach	Spar Österreichische Warenhandels AG	Austria	9241 Förderlach	Meat processing	Meat (pork, beef and veal)	Packaging of fresh meat. Production of sausages, smoked meat, ham, bacon and meat paste.
#010	Agrana Stärke Aschach	Agrana Stärke GmbH	Austria	4082 Aschach a.d.D.	Starch production	Maize	Starch, glucose syrups, derivatives
#011	Agrana Stärke Gmünd	Agrana Stärke GmbH	Austria	3950 Gmünd	Starch production	Potato and maize	Starch, modified starch, maltodextrins, syrup, long-life potato products, baby food
#012	Agrana Stärke Pischelsdorf	Agrana Stärke GmbH	Austria	3435 Pischelsdorf	Starch production	Wheat	Starch, gluten, wheat bran
	Agrana Bioethanol Pischelsdorf	Agrana Stärke GmbH		3435 Pischelsdorf		Wheat and maize	Bioethanol, animal feed
#014	Agrana Zucker Tulln	Agrana Zucker GmbH	Austria	3430 Tulln	Sugar manufacturing	Sugar beet	Sugar and animal feed
#015	Agrana Zucker Leopoldsdorf	Agrana Zucker GmbH	Austria	2285 Leopoldsdorf im Marchfelde	Sugar manufacturing	Sugar beet	Sugar and animal feed
#016	Bunge, Bruck an der Leitha	Bunge Austria GmbH	Austria	2460 Bruck an der Leitha	Oilseed processing and vegetable oil refining	Sunflower seeds, rapeseeds	Oil for human consumption and for technical purposes
#017	FrieslandCampina Professional	NV Frieslandcampina Professional	Belgium	Lummen	Dairies	Milk and others	Mix of dairy, bakery products, confectionery
#018	Belgomilk	Belgomilk cvba	Belgium	Beveren	Dairies	Milk, whey protein concentrate and vegetable oils	Milk, cream and milk powder
#019	Friesland Campina Belgium	Frieslandcampina Belgium NV	Belgium	Aalter	Dairies	Milk and others	Milk, drinks, chocolate and cream in cartons, multilayer PE bottles and cups, concentrated milk products (in bulk) and milk (in bulk)

Installation code	Installation name	Company name	Member State	Town	Main FDM sector	Raw materials	Products
#022	Danone Hombourg Recolte	Danone Hombourg Recolte NV	Belgium	Rotselaar	Dairies	Milk	Skimmed milk and cream
#024	Belgomilk	Milcobel cvba	Belgium	Moorslede	Dairies	Milk	Cheese
#025	Belgomilk	Milcobel cvba	Belgium	Schoten	Dairies	Milk	Drink milk, speciality products
#027	Tiense Suikerraffinaderij	Tiense Suikerraffinaderij NV	Belgium	Tienen	Sugar manufacturing	Sugar beet	Sugar
#029	Noliko	Scana Noliko nv	Belgium	Bree	Fruit and vegetables	Fruit and vegetables	Processed preserved fruit and vegetables, sauces and prepared meals
#030	Ardo/Ardo E. Haspeslagh	Ardo/Ardo E. Haspeslagh	Belgium	Ardoeie	Fruit and vegetables	Vegetables	Processed vegetables (frozen)
#031	Clarebout Potatoes	NV Clarebout Potatoes	Belgium	Heuvelland	Fruit and vegetables	Potatoes	Potato products
#032	d'Arta	N.V./N.V. D'Arta / D'Arta Menu	Belgium	Ardoeie	Fruit and vegetables	Vegetables	Processed vegetables
#035	Unifrost	N.V. Unifrost	Belgium	Ardoeie	Fruit and vegetables	Vegetables and potatoes	Processed vegetables and potatoes (frozen)
#036	Pluma	NV Pluma	Belgium	Wommelgem	Meat processing	Meat	Fresh meats and hams, pâtés, cooked sausages, meat loaf (pasteurised, fried or smoked)
#038	Forfarmers Belgium	B.V.B.A. for farmers Belgium	Belgium	Izegem	Animal feed	Animal (1–20 %) and vegetable raw materials (80–99 %)	Dry animal feed for pigs and broilers
#039	Degrave Voeders	N.V. Degrave Voeders	Belgium	Staden	Animal feed	Vegetable raw materials (milling and feed factory)	Animal feed for pigs (99 %) and cattle (1 %)
#041	Vanden Avenne-Ooigem	NV Vanden Avenne-Ooigem	Belgium	Wielsbeke	Animal feed	Animal (2 %) and vegetable (98 %) raw materials (milling and feed processing)	Animal feed (pigs, poultry and others)

Installation code	Installation name	Company name	Member State	Town	Main FDM sector	Raw materials	Products
#042	Aveve veevoeders	N.V. Aveve	Belgium	Merksem	Animal feed	Animal (< 1 % animal fat) and vegetable (> 99 %) raw materials	Animal feed (pigs, poultry, cattle and others) in bulk (80 %) and bags (20 %)
#043	Agrifirm	Agrifirm Belgium N.V.	Belgium	Grobbendonk	Animal feed	Animal (1.4 %) and vegetable raw materials	Animal feed (layers and pigs)
#044	Cargill	NV Cargill	Belgium	Antwerp	Oilseed processing and vegetable oil refining	Crushing and refining of rapeseeds	Meal, crude and refined oil
#045	Cargill	NV Cargill	Belgium	Izegem	Oilseed processing and vegetable oil refining	Multi-oil refining and bottling	Refined oils and fats, bottled oil
#046	Fuji Oil Europe	Fuji Oil Europe	Belgium	Ghent	Oilseed processing and vegetable oil refining	Edible oils	Palm oil, palm kernels, coconut, shea and others
#047	Alken-Maes	NV Brouwerijen Alken-Maes	Belgium	Alken	Brewing	Malted barley, unmalted wheat, barley, maize grits, sugar syrup	Beer in bottles and barrels
#048	Brouwerij Haacht	Brouwerij Haacht NV	Belgium	Boortmeerbeek	Brewing	Malt, corn, grains	Beer, drinks in bottles and barrels (different beer styles and sizes of batches)
#051	Konings	NV Konings	Belgium	Zonhoven	Soft drinks and nectar/juice made from fruit/vegetable	Fruit (apples and pears)	Fruit juices, concentrates
#056	frischli Milchwerk plant Rehburg-Loccum	frischli Milchwerke GmbH	Germany	Rehburg-Loccum	Dairies	Skimmed milk or concentrate of skimmed milk	Spray-dried skimmed milk powder
#057	Thalfang	Hochwald Foods GmbH	Germany	Thalfang	Dairies	Raw milk	Butter, skimmed milk powder, condensed milk

Installation code	Installation name	Company name	Member State	Town	Main FDM sector	Raw materials	Products
#058	Hünfeld	Hochwald Foods GmbH	Germany	Hünfeld	Dairies	Raw milk	Mozzarella cheese, whey concentrate, permeate concentrate; demineralised whey concentrate and powder
#059	Heilbronn	FrieslandCampina Germany GmbH	Germany	Heilbronn	Dairies	Raw milk	Yoghurt, dessert
#061	DMK Nordhackstedt	DMK GmbH	Germany	Zeven	Dairies	Raw milk	Mozzarella, Gouda, Edam
#062	wheyco Altentreptow	wheyco GmbH	Germany	Hamburg	Dairies	Whey	Lactose/whey protein concentrate production: WPC 35, 60, 80, lactose, whey powder, protein powder
#063	Lauben	Käseerei Champignon Hofmeister GmbH & Co. KG	Germany	Lauben	Dairies	Raw milk and whey powder	Soft cheese
#064	Upahl	Arla Foods Deutschland GmbH	Germany	Upahl	Dairies	Raw milk	Skimmed milk powder, yoghurt, UHT milk, pasteurised milk, quark, evaporated milk, whipped cream, crème fraiche, sour cream, buttermilk
#065	Karstädt	Arla Foods Deutschland GmbH	Germany	Karstädt	Dairies	Raw milk	Skimmed milk powder
#066	Pronsfeld	Arla Foods Deutschland GmbH	Germany	Pronsfeld	Dairies	Raw milk	Skimmed milk powder, UHT milk, pasteurised milk, evaporated milk, whipped cream, crème fraiche, sour cream, butter
#068	Neu-Ulm	Milchwerke Schwaben	Germany	Neu-Ulm	Dairies	NI	NI
#072	Augustiner-Bräu Wagner KG	NI	Germany	Munich	Brewing	NI	NI

Installation code	Installation name	Company name	Member State	Town	Main FDM sector	Raw materials	Products
#073	Paulaner Brauerei GmbH & Co. KG	NI	Germany	Munich	Brewing	NI	NI
#074	Betriebstätte 1	Kulmbacher Brauerei AG	Germany	Kulmbach	Brewing	NI	NI
#075	Anheuser-Busch InBev Germany Holding GmbH Brauerei Beck & Co.	Anheuser-Busch InBev Germany Holding GmbH Brauerei Beck & Co.	Germany	Bremen	Brewing	NI	NI
#076	Bitburger Brauerei Th. Simon GmbH	NI	Germany	Bitburg	Brewing	NI	NI
#077	Badische Staatsbrauerei Rothaus AG	NI	Germany	Grafenhausen-Rothaus	Brewing	NI	NI
#078	König-Brauerei GmbH	NI	Germany	Duisburg	Brewing	NI	NI
#079	Brauerei C. & A. Veltins GmbH & Co. KG	NI	Germany	Meschede	Brewing	NI	NI
#080	Krombacher Brauerei Bernhard Schadeberg GmbH & Co KG	Krombacher Brauerei Bernhard Schadeberg GmbH & Co KG	Germany	Kreuztal-Krombach	Brewing	NI	NI
#081	Karlsberg Brauerei GmbH	NI	Germany	Homburg	Brewing	NI	NI
#082	Mecklemburgische Brauerei Lübz GmbH	NI	Germany	Lübz	Brewing	NI	NI
#084	Holsten Brauerei AG	Holsten Brauerei AG	Germany	Hamburg	Brewing	NI	NI
#085	Werk Sünching	Südstärke GmbH	Germany	Sünching	Starch production	Potatoes	NI

Installation code	Installation name	Company name	Member State	Town	Main FDM sector	Raw materials	Products
#086	ADM Hamburg AG, Werk Hamburg	ADM	Germany	Hamburg	Oilseed processing and vegetable oil refining	Rapeseeds and soybeans	Rapeseed meal, soybean meal, refined rapeseed oil and refined soybean oil
#087	ADM Hamburg AG, Werk Noblee & Thörl	ADM	Germany	Hamburg	Oilseed processing and vegetable oil refining	Crude vegetable oils	Refined, hydrogenated, winterised and interesterfied vegetable oils
#088	ADM Soya Mainz	ADM	Germany	Mainz	Oilseed processing and vegetable oil refining	Soybeans	Soybean meal and once-refined soybean oil
#089	ADM Spyck GmbH	ADM	Germany	Spyck	Oilseed processing and vegetable oil refining	Rapeseeds and sunflower seeds	Rapeseed meal, sunflower meal, once-refined rapeseed oil and once-refined sunflower oil
#090	ADM Spyck GmbH, Werk Straubing	ADM	Germany	Straubing	Oilseed processing and vegetable oil refining	Rapeseeds	Rapeseed meal and once-refined rapeseed oil
#091	Mannheim	Bunge	Germany	Mannheim	Oilseed processing and vegetable oil refining	Rapeseeds	Rapeseed meal and refined rapeseed oil
#092	Mainz	Cargill	Germany	Mainz	Oilseed processing and vegetable oil refining	Crushing and refining of rapeseeds	Meal, crude and refined oil
#093	Riesa	Cargill	Germany	Riesa	Oilseed processing and vegetable oil refining	Crushing, refining and bottling of rapeseeds/sunflower seeds	Meal, crude and refined oil, bottled oil
#094	Salzgitter	Cargill	Germany	Salzgitter	Oilseed processing and vegetable oil refining	Crush and refinery rapeseeds, malt	Meal, crude and refined oil, malt

Installation code	Installation name	Company name	Member State	Town	Main FDM sector	Raw materials	Products
#095	Protein- und Oelwerk Neuss GmbH & Co. KG	C. Thywissen GmbH	Germany	Neuss	Oilseed processing and vegetable oil refining	Rapeseeds, sunflower seeds, linseeds	Vegetable oils (crude, semi-refined, refined, winterised), oilseed meals, lecithin
#096	Wilmar Edible Oils GmbH	Wilmar	Germany	Brake	Oilseed processing and vegetable oil refining	Crude palm oil, crude coconut oil, crude palm kernel oil	RPKO/RPO/POL56/PO L64/PST
#097	Kaufland Fleischwerk Handelshof GmbH	NI	Germany	Heilbronn	Meat processing	NI	NI
#098	Bauerngut	NI	Germany	Bückerburg	Meat processing	NI	NI
#102	Tulip Fleischwaren Oldenburg GmbH	Danish Crown	Germany	Oldenburg	Meat Processing	NI	NI
#105	Gerolsteiner Brunnen GmbH & Co.	NI	Germany	Gerolstein	Soft drinks and nectar/juice made from fruit/vegetable	NI	NI
#108	Könnern	Pfeier & Langen GmbH & Co. KG	Germany	Könnern	Sugar manufacturing	Sugar beet	Sugar
#109	Offenau	Südzucker AG	Germany	Offenau	Sugar manufacturing	Sugar beet	Sugar
#111	Nordstemmen	Nordzucker AG	Germany	Nordstemmen	Sugar manufacturing	Sugar beet	Sugar
#112	Rain	Südzucker AG	Germany	Rain	Sugar manufacturing	Sugar beet	Sugar
#113	Klein Wanzleben	Nordzucker AG	Germany	Klein Wanzleben	Sugar manufacturing/ Ethanol production	Sugar beet	Sugar
#114	Zeitz	CropEnergies AG (Südzucker Group)	Germany	Zeitz	Ethanol production	Cereals, sugar beet, syrups	Ethanol and feed (DDGS)

Installation code	Installation name	Company name	Member State	Town	Main FDM sector	Raw materials	Products
#115	Werk Aldrup	Agrarfrost GmbH & Co. KG	Germany	Wildeshausen	Fruit and vegetables	Potatoes	Potato products, deep-frozen; potato flakes
#116	Werk Oschersleben	Agrarfrost GmbH & Co. KG	Germany	Oschersleben	Fruit and vegetables	Potatoes	Potato products, deep-frozen; potato crisps
#118	Mars	PetCom Tierernährung GmbH & Co. KG	Germany	Minden	Animal feed	NI	Pet food
#119	Zweigniederlassung Apolda	Ospelt Petfood Anstalt	Germany	Apolda	Animal feed	NI	Pet food
#121	Landshuter Kunstmühle C.A. Meyers Nachfolger AG	NI	Germany	Landshut	Grain milling	NI	NI
#123	Rosenmühle Ergolding	Kampffmeyer Mühlen GmbH	Germany	84030 Ergolding	Grain milling	NI	NI
#124	Rødkærsbro Dairy	Arla Foods amba	Denmark	Rødkærsbro	Dairies	Mainly milk but also cheese, salt and other ingredients	Mozzarella in blocks and shredded, e.g. mixed with other kind of cheese
#125	Taulov Dairy	Arla Foods amba	Denmark	Fredericia	Dairies	Mainly milk but also salt and other ingredients	Different types of yellow cheese
#126	Nr. Vium Dairy	Arla Foods amba	Denmark	Videbæk	Dairies	Mainly milk but also cheese, salt and other ingredients	Yellow cheese (Havarti), slicing and packaging of cheese
#127	Holstebro Cream cheese	Arla Foods amba	Denmark	Holstebro	Dairies	Processed milk	Cream cheese, plain and mixed with spices
#128	Holstebro Dairy	Arla Foods amba	Denmark	Holstebro	Dairies	Mainly milk, cream, salt, vegetable oil	Butter and spreads
#129	Kruså Dairy	Arla Foods amba	Denmark	Kruså	Dairies	Mainly milk, salt and other ingredients	White cheese packed in e.g. vegetable oil with olives etc.
#130	Danmark Protein	Arla Foods Ingredients	Denmark	Videbæk	Dairies	Mainly whey	Whey powder, lactose and other products from whey

Installation code	Installation name	Company name	Member State	Town	Main FDM sector	Raw materials	Products
#131	Arinco	Arla Foods amba	Denmark	Videbæk	Dairies	Mainly milk	Milk powder, infant products
#132	Esbjerg Dairy	Arla Foods amba	Denmark	Esbjerg	Dairies	Mainly milk and also many different ingredients	Cocoa beverages, soups and other products based on animal and vegetable raw materials, UHT and ESL milk
#133	Slagelse Dairy	Arla Foods amba	Denmark	Slagelse	Dairies	Mainly milk	Fresh milk (different variants), cream, dessert
#134	Thise Dairy	Thise Dairy	Denmark	Roslev	Dairies	Mainly milk	Fresh milk (different variants), yoghurt, cream, cheese, butter
#135	Tulip Esbjerg	Tulip Food Company	Denmark	Esbjerg	Meat processing	Primarily red meat	Soups, ducklings and ready meals
#136	Tulip Aalborg	Tulip Food Company	Denmark	Aalborg	Meat processing	Primarily red meat	Meatballs, toppings and meat for burgers
#137	Tulip Svenstrup	Tulip Food Company	Denmark	Svenstrup	Meat processing	Primarily red meat	Sausages and salami
#138	Tulip Vejle	Tulip Food Company	Denmark	Vejle	Meat processing	Primarily red meat	Sausages, canned meat and liver pâté
#140	Danish Crown Skjern	Danish Crown	Denmark	Skjern	Meat processing	Beef and veal	Cut beef
#144	Skagerac Pelagic, Tobiskaj	Skagerac Pelagic	Denmark	Skagen	Fish and shellfish processing	Fresh herring and mackerel	Filleted and salted herring
#146	DLG Fabrik Tjele, Vingevej 70	DLG, Axelborg, Vesterbrogade 4A, 1503 København V	Denmark	Tjele	Animal feed	Grain, soya, protein raw material, minerals premix	Mainly pelleted feed for pigs and poultry
#147	DLG Fabrik Bårse, Korndrevet 4	DLG, Axelborg, Vesterbrogade 4A, 1503 København V	Denmark	Præstø	Animal feed	Grain, soya, protein raw material, minerals premix	Mainly pelleted feed for pigs and poultry
#148	DLG Skærbæk, Industrivej 36	DLG, Axelborg, Vesterbrogade 4A, 1503 København V	Denmark	Skærbæk	Animal feed	Grain, soya, protein raw material, minerals premix	Mainly pelleted feed for cattle and pigs

Installation code	Installation name	Company name	Member State	Town	Main FDM sector	Raw materials	Products
#149	AKV Langholt	AKV Langholt	Denmark	Langholt	Starch production	Potatoes	Potato starch, potato protein
#150	AKK	AKK	Denmark	Karup	Starch production	Potatoes	Potato starch, potato protein
#151	AKM	AKM	Denmark	Brande	Starch production	Potatoes	Potato starch, potato protein
#152	AKS	AKS	Denmark	Toftlund	Starch production	Potatoes	Potato starch, potato protein
#153	Rynkeby	Arla Foods amba	Denmark	Ringe	Soft drinks and nectar/juice made from fruit/vegetable	Mainly juices from fruit and vegetables, as single strength and concentrate but also fruit purées and dry frozen berries	Fruit juice, nectar, fruit drinks, fruit sups
#154	Carlsberg Danmark A/S	Carlsberg Danmark A/S	Denmark	Fredericia	Brewing	Malt, hops, water, sugar, concentrates	Finished beer, soft drinks, cider
#155	Scanola	Scanola A/S	Denmark	Aarhus	Oilseed processing and vegetable oil refining	Rapeseeds	Rapeseed oil and rape pellets
#156	AAK Denmark A/S	AAK Denmark A/S	Denmark	Aarhus	Oilseed processing and vegetable oil refining	Shea, rapeseeds, cocoa	Vegetable oil and fats
#157	Mahou Fca. Cerveza	Mahou San Miguel	Spain	Alovera (Guadalajara)	Brewing	Malt	Beer and non-alcoholic beer (up to 1% abv)
#158	San Miguel Fca. Cerveza	Mahou San Miguel	Spain	Lérida	Brewing	Malt	Beer and non-alcoholic beer (up to 1% abv)
#159	San Miguel Fca. Cerveza	Mahou San Miguel	Spain	Málaga	Brewing	Malt	Beer and non-alcoholic beer (up to 1% abv)
#160	San Miguel Fca. Cerveza	Mahou San Miguel	Spain	Burgos	Brewing	Malt	Beer and non-alcoholic beer (up to 1% abv)
#161	La Coruña	Hijos de Rivera SAU	Spain	La Coruña	Brewing	Malt	Beer and non-alcoholic beer (up to 1% abv)
#165	Jaén	Heineken España, S.A.	Spain	Jaén	Brewing	Malt	Beer and non-alcoholic beer (up to 1% abv)

Installation code	Installation name	Company name	Member State	Town	Main FDM sector	Raw materials	Products
#166	El Prat	Compañía Cervecería Damm	Spain	El Prat de Llobregat	Brewing	Malt	Beer and non-alcoholic beer (up to 1% abv)
#167	Espinardo	Estrella de Levante	Spain	Espinardo	Brewing	Malt	Beer and non-alcoholic beer (up to 1% abv)
#169	Carnes Selectas	Carnes Selectas 2000, S. A.	Spain	Burgos	Meat processing	NI	NI
#170	Tarancón	Incarlopsa	Spain	Tarancón	Meat processing	Pork carcasses, fresh pork meat, frozen meat, deboned cured hams	Pork carcasses and pork cutting products and trimmings, sliced cured ham
#171	Cartama Estacion	Mataderos Industriales Soler, S.A. y Frigoríficos Andaluces de Conservas de Carne S.A.	Spain	Cartama estacion	Meat processing	Pigs	Deboned meats, dried meat, dried sausages, frozen meat
#172	Tarancón	Incarlopsa- Fábrica de elaborados	Spain	Tarancón	Meat processing	Fresh meat (pig, turkey, chicken)	Processed meat (cooked, fresh, and cured)
#173	Binéfar	Fribin	Spain	Binéfar	Meat processing	Pork and beef	Bovine and pork meat quartering and packing (chilled and frozen)
#174	Matadero frigorífico de Begíjar, S.A.	Matadero frigorífico de Begíjar, S.A.	Spain	Begíjar (Jaén)	Meat processing	Pigs	Pork carcasses, pork viscera and lean pork
#175	Campofrio Torrent	Campofrio Food Group, S.A.	Spain	Torrent (Valencia)	Meat processing	Beef, pork, poultry	Cooked sausages, sliced bacon, pieces of cooked meat (fiambre), sliced cooked meat
#176	Campofrio Villaverde	Campofrio Food Group, S.A.	Spain	Villaverde (Madrid)	Meat processing	Pork, poultry	Sausages, cured ham
#177	Alcolea	Deoleo	Spain	Alcolea (Córdoba)	Fruit and vegetables	Oil, sauces, vinegar	Refinery and packaging of olive oil. Production and packaging of sauces (mayonnaise, ketchup and mustard). Production and packaging of vinegar

Installation code	Installation name	Company name	Member State	Town	Main FDM sector	Raw materials	Products
#178	Conservas Vegetales de Extremadura	Conesa	Spain	Badajoz	Fruit and vegetables	Fresh tomatoes	Tomato dices and powder, concentrated tomato pulp
#179	Alimentos españoles alsat, S.L.	Alsat	Spain	Don Benito (Badajoz)	Fruit and vegetables	Tomatoes	Tomato industrial products: concentrated pulp and tomato dices
#181	Azucarera La Bañeza	AB Azucarera Iberia	Spain	La Bañeza (León)	Sugar manufacturing	Sugar beet	Sugar, pulp and molasses
#182	Azucarera Guadalete	AB Azucarera Iberia	Spain	Jerez de la Frontera (Cádiz)	Sugar manufacturing	Sugar beet and raw sugar	Sugar, pulp and molasses
#183	Toledo	Orangina - Schweppes	Spain	Toledo	Soft drinks and nectar/juice made from fruit/vegetable	Water, sugar, juices, compounds fruits and wine	Lines with multiproduct. Still and carbonated beverages. Soft drinks with juices fruits, soft drink flavoured, juices, nectars
#184	Málaga	Coca-Cola Iberian Partners	Spain	Málaga	Soft drinks and nectar/juice made from fruit/vegetable	Water, sugar, juices, and compounds fruits	NI
#185	Bilbao	Coca-Cola Iberian Partners	Spain	Bilbao	Soft drinks and nectar/juice made from fruit/vegetable	Water, sugar, juices, and compounds fruits	NI
#186	Echevarri	Pepsico	Spain	Alava	Soft drinks and nectar/juice made from fruit/vegetable	Water, sugar, juices, and compounds fruits	NI
#187	Roquette Laisa España S.A.	Roquette Laisa España S.A.	Spain	Benifaió	Starch production	Corn	Corn starches (native and modified) and its derivatives (glucose syrups, glucose and fructose syrups and dextrose). Maize gluten, maize gluten feed, maize germ expeller, corn oil.

Installation code	Installation name	Company name	Member State	Town	Main FDM sector	Raw materials	Products
#189	Aldaia Plant	Danone	Spain	Aldaia	Dairies	Milk	Fermented milk, yoghurt, and milk desserts
#190	Salas Plant	Danone	Spain	Salas	Dairies	Milk	Milk desserts and fresh cheese
#191	Parets Plant	Danone	Spain	Parets del Vallès	Dairies	Milk	Yoghurt, milk desserts and fermented soya products
#193	Granada	Puleva Food, S.L.	Spain	Granada	Dairies	Milk, orgeat and cream	Drinking milk, functional milk, flavoured milk, orgeat
#194	Mollerussa	Puleva Food, S.L.	Spain	Mollerussa	Dairies	Milk	Functional and drinking milk
#195	Lugo	Puleva Food, S.L.	Spain	Lugo	Dairies	Milk	Functional and drinking milk, milk powder and concentrated milk
#196	Valladolid	Industrias Lacteas Vallisoletanas, S.L.U.	Spain	Valladolid	Dairies	Milk	Functional and drinking milk
#197	Villalba	Leche de Galicia, S.L.	Spain	Villalba (Lugo)	Dairies	Milk	Drinking milk
#198	Villarrobledo	Lactalis Villarrobledo, S.L.U.	Spain	Villarrobledo	Dairies	Cow and goats' milk	Cheese and whey powder
#199	Guadalajara	L.N.P.L.R. Guadalajara S.L.	Spain	Guadalajara	Dairies	Milk, concentrated milk and cream	Yoghurt and dairy desserts
#203	Valladolid	Queserías entrepinares	Spain	Valladolid	Dairies	Milk and cheese	Pressed cheese
#209	Granda	Corporación Alimentaria Peñasanta, S.A.	Spain	Granda	Dairies	Milk	UHT milk, powder milk, butter, yoghurt
#210	Lugo	Corporación Alimentaria Peñasanta, S.A.	Spain	Lugo	Dairies	Milk	UHT milk, powder milk
#211	Zarzalejo	Corporación Alimentaria Peñasanta, S.A.	Spain	Zarzalejo	Dairies	Milk	UHT milk

Installation code	Installation name	Company name	Member State	Town	Main FDM sector	Raw materials	Products
#212	Vidrerres	Vidrerres Llet, S.L	Spain	Vidrerres	Dairies	Milk	UHT milk
#214	Aranda	Calidad Pascual, S.A.U.	Spain	Aranda de Duero	Dairies	Milk, soya seeds and fruit juices concentrate	Milk, dairy drinks, soya drinks, yoghurts and dairy desserts, butter
#215	Gurb	Calidad pascual,s.a.u.	Spain	Gurb (Barcelona)	Dairies	Milk	Milk
#216	Alcázar de San Juan	Lácteas García Baquero, S.A.	Spain	Jumilla	Dairies	Cow, goat and sheep's milk	Cheese
#217	Zaragoza	Cuarte, S.L.	Spain	Zaragoza	Animal feed	Cereals, minerals, oleagins, fat	Compound feed
#218	Plasencia del Monte	Harineras Villamayor, S.A.	Spain	Plasencia del Monte	Grain milling	NI	Flour
#220	La Rambla - Córdoba	San Lorenzo, S.A	Spain	La Rambla - Córdoba	Grain milling	Wheat	Flour
#222	Torija - Guadalajara	Harinas Torija, S.L.	Spain	Torija - Guadalajara	Grain milling	Wheat	Flour
#223	Barcelona	Cargill	Spain	Barcelona	Oilseed processing and vegetable oil refining	Soya	Crude soya oil, soya hulls, low-protein meal and high-protein meal
#224	Reus	Cargill	Spain	Reus	Oilseed processing and vegetable oil refining	Sunflower seeds, maize, soya	Crude sunflower oil, low-protein and high-protein meal, refined sunflower oil, refined maize oil
#225	Barcelona	Bunge	Spain	Barcelona	Oilseed processing and vegetable oil refining	Soybeans	Soybean meal and Soybean refined oil
#226	Zierbena	Bunge	Spain	Bilbao	Oilseed processing and vegetable oil refining	Soybeans and sunflower crude oil	Soybean meal, refined soybean oil and refined sunflower oil

Installation code	Installation name	Company name	Member State	Town	Main FDM sector	Raw materials	Products
#227	Escombreras	Bunge	Spain	Cartagena	Oilseed processing and vegetable oil refining	Soybeans and sunflower crude oil	Soybean meal, refined soybean oil and refined sunflower oil
#228	Valio Riihimäki	Valio Ltd	Finland	Riihimäki	Dairies	Milk	Liquid milks, yoghurts, desserts
#229	Valio Jyväskylä	Valio Ltd	Finland	Jyväskylä	Dairies	Milk	Liquid milk, special milk drinks
#230	Valio Tampere	Valio Ltd	Finland	Tampere	Dairies	Milk	Liquid milk, soft cheese
#231	Valio Oulu	Valio Ltd	Finland	Oulu	Dairies	Milk	Liquid milks, yoghurts, desserts, sour creams
#232	Valio Haapavesi	Valio Ltd	Finland	Haapavesi	Dairies	Milk	Semi-hard cheese, demineralised whey powders
#233	Valio Joensuu	Valio Ltd	Finland	Joensuu	Dairies	Milk	Semi-hard and soft cheese, milk and whey powders, milk drink components
#234	Valio Lapinlahti	Valio Ltd	Finland	Lapinlahti	Dairies	Milk	Hard and semi-hard cheese, demineralised whey powders
#235	Valio Seinäjoki	Valio Ltd	Finland	Seinäjoki	Dairies	Milk	Butter, spreads, cottage cheese, quark, milk powders
#236	Apetit Oyj Säkylä WWTP (serving IED 6.4.ii activities also from other companies)	Apetit Suomi Oy	Finland	Säkylä	Fruit and vegetables	Apetit Oyj: peas, carrots, potatoes, spinach, yellow turnips, red beets, celery, leeks. Sucros Ltd: sugar beet. Hankkija Oyj: hard pressed sugar beet pulp.	Frozen vegetables, sugar, animal feed from sugar manufacturing
#237	Finnamyl Oy	Finnamyl Oy	Finland	Kokemäki	Starch production	Potatoes	Potato starch and feed

Installation code	Installation name	Company name	Member State	Town	Main FDM sector	Raw materials	Products
#238	Finnsugar Ltd. Porkkala factory (WWTP serving also other companies and the community)	Finnsugar Ltd.	Finland	Kirkkonummi	Sugar manufacturing	Finnsugar Ltd: raw cane sugar, raw beet sugar Mildola Oy: oil plant seeds (e.g. rapeseeds, soybeans)	Finnsugar Ltd: dry sugar products, liquid sugar products, syrups, food molasses, side products Mildola Oy: vegetable oils, protein feed
#239	Sinebrychoff Kerava	Sinebrychoff Supply Company	Finland	Kerava	Brewing	Water, malt, sugar, juice concentrates, flavours, carbon dioxide	Beer, ciders, flavoured alcoholic beverages, soft drinks, carbonated water
#242	Hankkija Oy / Säkylä factory	Hankkija Oy	Finland	Säkylä	Sugar manufacturing	Sugar beet pulp	Dried sugar beet pulp
#243	Iisalmi brewery	Olvi Oyj	Finland	Iisalmi	Brewing	Malt, water, hops, sugar, sweeteners, apple and peach base, compounds,	Beer, cider, RTD, soft drinks, mineral water, sports drinks
#245	Biomar - Nersac	BioMar	France	16440 Nersac	Animal feed	Cereals, oilseeds, vegetable proteins, fishmeal, fish oil, vegetable oils, additives	Compound feed for marine and freshwater fishes, various sizes, with and without land animal products. Only fish feed.
#246	Huttepain Aliments - La Chapelle Saint Aubin	Huttepain Aliments	France	La Chapelle Saint Aubin	Animal feed	Vegetable raw materials	Animal feed (poultry)
#247	Brasserie de l'Espérance _ Schiltigheim	Heineken	France	Schiltigheim	Brewing	NI	NI
#248	Brasserie Kronenbourg Obernai	Kronenbourg	France	Obernai	Brewing	NI	NI
#249	Brasserie Licorne SAS	Brasserie Licorne SAS	France	Saverne	Brewing	NI	Beer, shandy, energy drinks
#250	Candia - Awoingt	Candia (Groupe Sodiaal)	France	Awoingt	Dairies	Milk (95%), milk powder, vegetable oils, cacao	UHT white milk, flavoured milk, liquid cream, milk powder, infant formula

Installation code	Installation name	Company name	Member State	Town	Main FDM sector	Raw materials	Products
#251	Celia-laiterie de craon	Lactalis	France	53400 Craon	Dairies	Milk, powder, cream, permeate,	Hard cheese, milk powder, infant formula, retentate, concentrated whey, cream
#252	Entremont - Guingamp	Sodiaal	France	Guingamp	Dairies	Milk, vegetable oils, cream, concentrated milk and whey, whey	Cheese, powder, concentrated whey, cream
#253	Entremont - Malestroit	Sodiaal	France	Malestroit	Dairies	Milk, concentrated milk and whey	Cheese, powder, cream, demineralised powder
#254	Entremont - Quimper	Sodiaal	France	Quimper	Dairies	Milk, buttermilk, pre-concentrated (whey, permeate)	Cheddar, powder, retentate, cream
#255	Eurosérum, Saint-Martin	Euroserum	France	Saint-Martin-Belle-Roche	Dairies	Milk, concentrated whey	Cream, milk powder, whey powder, milk powder, infant formula, retentate, concentrated whey
#256	Fromagerie BEL - Dole	Groupe BEL	France	Dole	Dairies	Cheese, butter, cream	Processed cheese
#257	Fromagerie BEL - Sablé sur Sarthe	Groupe BEL	France	Sablé sur Sarthe	Dairies	Milk, cream, powder milk and whey	Cheddar, powder, retentate, cream
#258	Usine de Vallet	Lactalis	France	Vallet	Dairies	Milk, sugar, chocolate, fruits, rice	Dessert
#259	Laiterie d'Ancenis	Laita	France	Ancenis	Dairies	Milk, cream	Powder, cheese, butter
#260	Societe Beurriere de Retiers	Lactalis	France	Retiers	Dairies	NI	Butter, buttermilk
#261	Societe Fromagere du Massegros	Lactalis	France	Le Massegros	Dairies	Sheep milk	Cheese: sheep's milk (feta), concentrated whey, liquid serum
#262	Danone - Le Molay Littry	Danone	France	Le Molay Littry	Dairies	Mainly milk, but also cereals, milk powder, sugar, fruits preparation, chocolate, starch	Fresh cheese, yoghurt, desserts, liquid whey

Installation code	Installation name	Company name	Member State	Town	Main FDM sector	Raw materials	Products
#263	Grands Moulins de Paris Site de Verneuil-l'Étang	Grands moulins de Paris	France	Verneuil-l'Étang	Grain milling	Wheat	NI
#264	APM Pleurs	APM Deshy	France	Pleurs	Animal feed	Alfalfa (field culture) and sugar beet pulp (sugar manufacturing co-product)	Dehydrated alfalfa (pellets, bales), dehydrated sugar beet pulp (pellets), other dehydrated products (pellets)
#265	Luzeal Recy Voie Chanteraine	Luzeal	France	Recy	Animal feed	Alfalfa (field culture) and sugar beet pulp (sugar manufacturing co-product)	Dehydrated alfalfa (pellets, bales), dehydrated sugar beet pulp (pellets), other dehydrated products (pellets)
#266	Charal	Charal	France	Flers	Meat processing	2 nd and 3 rd level of beef meat processing	NI
#267	Duc	Duc	France	Riec-sur-Bélon	Meat processing	Cutting of turkey and production of breaded turkey	NI
#268	Madrangé		France	Limoges	Meat processing	Pork meat, salt, seasoning	Cooked ham
#269	Saviel France Etablissement de Tain l'Hermitage	Saviel France	France	Tain l'Hermitage	Meat processing	3 rd and 4 th level of meat processing: -3 rd : cutting of beef, lamb, pork and veal meat and offal	Brochettes (3 rd) and sausages (4 th), chilled minced meat (3 rd and 4 th)
#270	Site Aoste	Groupe Aoste	France	Aoste	Meat processing	Pork meat	Production of dry sausage, cured ham, slicing of delicatessen products
#271	Raynal et Roquelaure zi les Taillades	Raynal et Roquelaure	France	Capdenac Gare	Meat processing	Meat, cooked vegetables	Traditional and exotic dishes made with cooked meat and vegetables
#272	Cargill St Nazaire Boulevard Leferme	Cargill	France	St Nazaire	Oilseed processing and vegetable oil refining	Crushing and refining of sunflowerseeds	Meal, crude and refined oil

Installation code	Installation name	Company name	Member State	Town	Main FDM sector	Raw materials	Products
#273	Lesieur Coudekerque	Lesieur	France	Coudekerque	Oilseed processing and vegetable oil refining	Crude oil (rape, sunflower, soya, corn)	Refined oil, acid oils, refined-oil bottling
#274	Saipol Bassens	Saipol	France	Bassens	Oilseed processing and vegetable oil refining	Rapeseeds, sunflower seeds	Refined oil, neutral oil, meal
#275	Saipol Sète	Saipol	France	Sete	Oilseed processing and vegetable oil refining	Rapeseeds, sunflower seeds	Refined oil, neutral oil, acid oils, meal
#276	MARS Petcare & Food France - Boulevard des Chenêts	Mars Inc	France	Saint-Denis-de-l'Hôtel	Animal feed	Frozen and fresh meats, cereals and vegetables	Wet pet food for cats and dogs
#277	Royal Canin SAS	Royal Canin subsidiary of Mars Inc	France	Aimargues	Animal feed	Specific raw materials depending on the recipe	Dry pet food for cats and dogs
#278	Pepsico / Tropicana	Pepsico	France	Hermes	Soft drinks and nectar/juice made from fruit/vegetable	Fruit juices, vegetable juices, compounds fruits, and other ingredients	Fruit or vegetable juice
#279	Refresco France-Site de Délifruits	Refresco France	France	Marges	Soft drinks and nectar/juice made from fruit/vegetable	Fruit juices, concentrated fruit juices, vegetable juices, concentrated vegetable juices, water, sugar, sweeteners, compounds, fruits, other ingredients	Fruit or vegetable juice, fruit or vegetable juice made from concentrate, fruit or vegetable nectar, soft drinks, fruit drinks

Installation code	Installation name	Company name	Member State	Town	Main FDM sector	Raw materials	Products
#280	Chamtor Bazancourt	Chamtor	France	Bazancourt	Starch production	Wheat	Wheat native starch and its derivatives (glucose syrups, glucose and fructose syrups) and its co-products (wheat gluten, wheat hydrolysed gluten, wheat soluble feed, wheat germ, wheat bran) and other derivatives such as fermentation products
#281	Roquette Beinheim	Roquette Freres	France	Beinheim	Starch production	Maize and wheat	Maize and wheat starches (native and modified) and their derivatives (glucose syrups, glucose and fructose syrups) and their co-products (maize gluten, wheat gluten, maize gluten feed, wheat feed, maize soluble, maize germ expeller, com oil) and bioethanol production
#282	Roquette Lestrem	Roquette Freres	France	Lestrem	Starch production	Maize and wheat	Maize and wheat starches (native and modified) and their derivatives (glucose syrups, glucose and fructose syrups and dextrose, maltodextrins) and their co-products (maize gluten, wheat gluten, maize gluten feed, wheat feed, maize soluble, maize germ expeller, com oil) and other derivatives such as polyols and fermentation products and isosorbide
#283	Roquette Vecquemont	Roquette Freres	France	Vecquemont	Starch production	Starch potatoes	Potato starches (native and modified) and their co-products (potato protein, fibres (pulps))
#284	Roquette Vic	Roquette Freres	France	Vic sur Aisne	Starch production	Starch peas	Pea starches (native and modified) and their co-products (protein, fibres)

Installation code	Installation name	Company name	Member State	Town	Main FDM sector	Raw materials	Products
#285	SAS Lesaffre Frères	SAS Lesaffre Frères	France	Nangis	Sugar manufacturing	Sugar beets only	Sugar production, animal feed from sugar beet pulp
#286	Tereos France site d'Origny Sainte Benoîte	Tereos	France	Origny Sainte Benoîte	Sugar manufacturing	Sugar beets (sugar and ethanol), wheat (ethanol)	Sugar and ethanol production, animal feed from sugar beet pulp and DDGS
#287	Cristal Union + Cristanol	Cristal Union	France	Bazancourt	Sugar manufacturing	Sugar beets (sugar and ethanol), wheat (ethanol)	Sugar and ethanol production, animal feed from sugar beet pulp and DDGS
#288	Tereos France site de Bucy le long	Tereos	France	Bucy le long	Sugar manufacturing	Sugar beets only	Sugar and ethanol (raw ethanol) production, animal feed from sugar beet pulp
#289	ARDO Gourin	ARDO	France	Gourin	Fruit and vegetables	Spinach, green beans, cauliflower, broccoli, carrots, potatoes, peas	Production, packaging and storage of frozen vegetable
#290	Borderes et Lamensans	Société Sud Ouest Legumes S.A.	France	Borderes et Lamensans	Fruit and vegetables	Sweet corn, peas, beans	Canned and frozen vegetables
#291	Conserves France	Saint Mamet SAS	France	Vauvert	Fruit and vegetables	Fruits	Fruits in syrup, compotes, jams
#292	Alfalfa Manufacturing	Cristal Union	France	Bazancourt	Animal feed	Alfalfa	Pellets
#293	Abbott Ireland	Abbott	Ireland	Cootehill, Co Cavan	Dairies	Milk	Infant Formula
#294	Glanbia Ingredients (Ballyragget) Limited	Glanbia Ingredients (Ballyragget) Limited	Ireland	Ballyragget, Co. Kilkenny	Dairies	Milk, whey concentrate, cream	Butter, butter oil, lactic butter, cheddar cheese, cagliata, rennet casein, attrition acid casein, milk protein concentrate, MPC permeate, milk protein isolate, skimmed milk powder, skimmed concentrate, buttermilk powder, whey protein concentrate, whey protein isolate, lactose, delactosed permeate, cream

Installation code	Installation name	Company name	Member State	Town	Main FDM sector	Raw materials	Products
#295	Carbery Milk Products Limited	Carbery Milk Products Limited	Ireland	Ballineen, Co. Cork	Dairies	Milk and whey	Cheese, whey protein powders, whey protein isolates, sports food, creams, skimmed milk powder, alcohol, yeast extract powder
#296	Kerry Ingredients (Ireland) Limited	Kerry	Ireland	Listowel, Co. Kerry	Dairies	Milk, oils, cheese	Butter, butter oil, casein powders, whey powders, cheese powder, malt powder, spreads, processed cheese, milk protein isolate, dairy flavours, cream powders, milk protein hydrolysate
#297	Glanbia Foods Society Limited	Glanbia Foods Society Limited	Ireland	Ballitore, Co. Kildare	Dairies	Raw cow's milk	Pasteurised milk and cream
#298	Oleificio Zucchi	Oleificio Zucchi S.p.A.	Italy	Cremona (CR)	Oilseed processing and vegetable oil refining	Crude seed oils: groundnut oil, corn oil, sunflower oil, soybean oil, rapeseed oil	Refined seed oils: groundnut oil, corn oil, sunflower oil, soybean oil, rapeseed oil
#299	Carapelli Firenze S.p.A. Inveruno Plant	Deoleo S.A.	Italy	Inveruno (MI)	Olive oil processing and refining	Crude olive-oil and seeds oil	Olive oil and refined oilseed oil
#300	Conselice	Unigra' SRL	Italy	Conselice (RA)	Oilseed processing and vegetable oil refining	Palm oil, oilseeds	Margarine, refined oil
#302	Salov Refinery	Salov S.P.A.	Italy	Massarosa (LU)	Olive oil processing and refining	Olive oil	Refined olive oil
#303	Itacol Spa	Itacol Spa	Italy	Castelfiorentino (FI)	Oilseed processing and vegetable oil refining	Sunflower seeds, rapeseeds, olive husks, grapeseeds	Crude oil, extraction meal and biomass for combustion
#304	Tampieri S.P.A.	Tampieri S.P.A.	Italy	Faenza (RA)	Oilseed processing and vegetable oil refining	Sunflower seeds, corn germ, pomace, grapeseeds	Sunflower oil (crude and refined), corn germ oil (crude and refined), grapeseed oil (crude and refined), sunflower meal, corn germ meal, grapeseed meal, acid oil

Installation code	Installation name	Company name	Member State	Town	Main FDM sector	Raw materials	Products
#305	Ital Green Oil S.r.l. (Veneto)	Ital Green Oil SRL	Italy	San Pietro di Morubio (VR)	Oilseed processing and vegetable oil refining	Soybeans	Crude soybean oil, soymeal high- and low-protein, lecithin, refined soybean oil
#306	Mangimificio di Quinto di Valpantena	Agricola Tre Valli Soc. Coop	Italy	Verona	Animal feed	Cereal grains and derived products, oilseeds and derived products, legume seeds and derived products, minerals, feed additives. land animals products, fish, other aquatic animals	Fish feed
#307	Via Nazionale Sannitica, 60	Mangimi Liverini Spa	Italy	Telese Terme (BN)	Animal feed	Cereal grains and derived products, oilseeds, forage, milk products, animal by-products, minerals, fermentation by-products, fatty acids, feed additives	Compound feed for cattle, dairy and laying hens
#308	Cargill Spessa	Cargill srl - Feed Nutrition	Italy	Spessa (PV)	Animal feed	Grains and by-products, oilseeds and oilseed meals, roughages like hay, and dehydrated alfalfa, sugar beet pulp, oils, minerals, vitamins and oligo premix, medicated and additives premixes,	Compound and concentrate feed for dairy, beef, sheep, rabbits, horses
#309	Purina Petcare	Nestlè Italiana S.p.A.	Italy	Portogruaro	Animal feed	Others	Dry pet food for dogs and cats
#310	Bologna	Granarolo Spa	Italy	Bologna	Dairies	Fresh pasteurised and extended shelf life milk. Fresh dairy products, cheese	Milk

Installation code	Installation name	Company name	Member State	Town	Main FDM sector	Raw materials	Products
#311	Gioia del Colle (Bari)	Granarolo Spa	Italy	Gioia del Colle (Bari)	Dairies	Fresh pasteurised and UHT milk, pasteurised cream	Milk
#312	Igor srl	Igor srl	Italy	Cameri (NO)	Dairies	Milk	Gorgonzola cheese
#313	Zanetti spa-marmirolo	Zanetti spa	Italy	Marmirolo (MN)	Dairies	Grana Padano cheese	Grana Padano cheese
#314	Collecchio Parma	Parmalat	Italy	Collecchio	Dairies	Milk, juices, sugar, flavour, aroma, fruits	UHT milk, UHT cream, bechamel, fruit juices, yoghurt, desserts
#315	Zevio Verona	Parmalat	Italy	Zevio	Dairies	Milk	UHT milk
#316	Barbiano	Conserva Italia soc coop agricola	Italy	Cotignola (RA)	Fruit and vegetables	Apricots, peaches, pears and apples	Fruit juice and nectars
#317	Solana SpA	Solana SpA	Italy	Maccastorna (LO)	Fruit and vegetables	Processing tomatoes and fruit and vegetables semifinished	Diced, crushed, passata, tomato paste and other tomato-based products, vegetable juices, pulps and concentrates for semi-finished products
#318	Mutti Spa	Mutti SpA	Italy	Montechiarugolo (PR)	Fruit and vegetables	Processing tomatoes	Diced, crushed, passata, tomato paste, tomato sauces and other tomato-based products
#319	Ferrara Food SpA	Ferrara Food	Italy	Argenta (FE)	Fruit and vegetables	Processing tomatoes and fruit and vegetables semifinished	Diced, crushed, passata, tomato paste and other tomato-based products, vegetable and fruit juices, pulps and concentrates for semi-finished products
#320	Rodolfi Mansueto SpA	Rodolfi Mansueto SpA	Italy	Collecchio (PR)	Fruit and vegetables	Processing tomatoes and vegetables semifinished	Diced, crushed, passata, tomato paste, tomato sauces and other tomato-based products, vegetable juices, pulps and concentrates for semifinished products

Installation code	Installation name	Company name	Member State	Town	Main FDM sector	Raw materials	Products
#321	Columbus Srl	Columbus Srl	Italy	Parma (PR)	Fruit and vegetables	Processing tomatoes	Diced, crushed, passata, tomato paste, tomato sauces and other tomato-based products
#322	Hans Zipperle spa	Hans Zipperle spa	Italy	Merano (BZ)	Fruit and vegetables	Fruit and vegetables	Fruit juices, pulps and concentrates for semi-finished
#323	SICA SRL	SICA SRL	Italy	Pagani (SA)	Fruit and vegetables	Canned tomatoes	Whole peeled tomatoes, crushed/diced tomatoes
#326	La Doria spa	La Doria spa	Italy	Fisciano (SA)	Fruit and vegetables	Canned tomatoes	Chopped and peeled
#327	Greci Industria Alimentare spa	Greci Industria Alimentare spa	Italy	Parma	Fruit and vegetables	Fruit and vegetables	Diced, crushed, passata, tomato paste, tomato sauces and other tomato-based products, canned vegetables (artichokes, mushrooms, etc.)
#328	S.F.I.R. Raffineria di Brindisi	S.F.I.R. Raffineria di Brindisi s.p.a.	Italy	Brindisi (BR)	Sugar manufacturing	Raw cane sugar	White sugar, molasses
#329	Zuccherificio di Minerbio	Co.Pro.B. SCA	Italy	Minerbio (BO)	Sugar manufacturing	Sugar beet	White sugar, molasses, dried and pressed beet pulp
#330	Cesare Fiorucci SpA	Campofrio foodholding	Italy	Pomezia (RM)	Meat processing	Raw pork	Salami, mortadelle, wurstel, prosciutti cotti/arrosti, pancette, coppe
#331	Cesena Production plant (Avi.Coop s.c.a)	Avi.Coop s.c.a.	Italy	Cesena (FC)	Meat processing	Poultry	Processed meat products
#333	Barilla G. e R. Fratelli S.p.A. (impianto molitorio a frumento duro)	Barilla G. e R. Fratelli S.p.A.	Italy	Altamura (BA)	Grain milling	Durum wheat	Durum wheat, durum wheat semolina

Installation code	Installation name	Company name	Member State	Town	Main FDM sector	Raw materials	Products
#334	Molini Lario S.p.A. (impianto molitorio a frumento tenero)	Molini Lario S.p.A.	Italy	A. Brianza (CO)	Grain milling	Soft wheat	Soft wheat semolina
#336	FrieslandCampina Workum	FrieslandCampina	Netherlands	Workum	Dairies	Milk and whey	Cheese and whey powder
#338	FrieslandCampina Beilen	FrieslandCampina	Netherlands	Beilen	Dairies	Milk and whey	Milk and whey powder
#339	FrieslandCampina Lochem	FrieslandCampina	Netherlands	Lochem	Dairies	Milk	Milk powder
#340	FrieslandCampina Borculo	FrieslandCampina	Netherlands	Borculo	Dairies	Whey	Whey-related powders and concentrates
#341	FrieslandCampina Lutjewinkel	FrieslandCampina	Netherlands	Lutjewinkel	Dairies	Milk	Cheese
#342	FrieslandCampina Maasdam	FrieslandCampina	Netherlands	Maasdam	Dairies	Milk	Consumer products like milk, yoghurt, dairy desserts
#344	FrieslandCampina Den Bosch	FrieslandCampina	Netherlands	Den Bosch	Dairies	Cream	Butter and butter-related products
#345	FrieslandCampina Veghel	FrieslandCampina	Netherlands	Veghel	Dairies	Milk and whey	Processed whey powders, cream, skimmed milk, milk powders
#351	Sugar production line/ Plant Chełmża	Nordzucker Polska S.A.	Poland	Chełmża	Sugar manufacturing	Sugar beet, raw cane sugar	Sugar, molasses, pulp
#352	Sugar production line/ Sugar Factory Głinojeck	Pfeifer& Langen Głinojeck S.A	Poland	Głinojeck	Sugar manufacturing	Sugar beet, raw cane sugar	Sugar, molasses, pulp
#353	Sugar production line/ Sugar Factory Miejska Górka	Pfeifer&Langen Polska S.A	Poland	Miejska Górka	Sugar manufacturing	Sugar beet	Sugar, molasses, pulp

Installation code	Installation name	Company name	Member State	Town	Main FDM sector	Raw materials	Products
#354	Sugar production line/ Sugar Factory Cerekiew	Suedzucker Polska S.A.	Poland	Ciężkowice	Sugar manufacturing	Sugar beet	Sugar, molasses, pulp
#355	Sugar production line/ Sugar Factory Ropczyce	Suedzucker Polska S.A.	Poland	Ropczyce	Sugar manufacturing	Sugar beet	Sugar, molasses, pulp
#356	Gerber Factory	Nestle Polska S.A.	Poland	Rzeszów	Fruit and vegetables	Processed vegetables and fruits	Baby food
#357	OSI Food Solutions Poland Sp. z o.o. Production Plant	OSI Food Solutions Poland Sp. z o.o.	Poland	Ostróda	Meat processing	Meat	Meat patties
#360	Tyski Browar Książecy	Kompania Piwowarska S.A.	Poland	Tychy	Brewing	Malt, sugar syrup, bitterness extract, granulated bitterness and aroma	Beer
#361	Bosman Browar w Szczecinie	Carlsberg Supply Company Polska S.A.	Poland	Szczecin	Brewing	Malt, barley, hops, water	Beer
#363	De Heus	De Heus	Poland	Łęczyca	Animal feed	Edible roots and tubers, oilseeds, cereal grains, feed with greens	Animal food
#365	ADM Szamotuly	ADM	Poland	Szamotuly	Oilseed processing and vegetable oil refining	Rapeseeds	Rapeseed meal and refined rapeseed oil
#366	Warsaw plant	Danone Sp. zo.o	Poland	Warsaw	Dairies	Milk	Yoghurt, flavoured milk
#367	Bieruń plant	Danone Sp. zo.o	Poland	Bieruń	Dairies	Milk	Yoghurt drinks, cottage cheese, yoghurt
#368	Ice Cream Factory	Nestle Polska S.A.	Poland	Namysłów	Dairies	Sugar, milk powder, liquid milk, whey powder, glucose syrup, coconut oil	Ice cream
#373	Sídul Açúcares, Unipessoal Lda.	Sídul Açúcares, Unipessoal Lda.	Portugal	Loures	Sugar manufacturing	Raw cane sugar	Dry sugar products

Installation code	Installation name	Company name	Member State	Town	Main FDM sector	Raw materials	Products
#374	Refrige, Sociedade Industrial de Refrigerantes, S.A	Refrige, Sociedade Industrial de Refrigerantes, S.A	Portugal	Palmela	Soft drinks and nectar/juice made from fruit/vegetable	Water, sugar, juice concentrates, flavours, carbon dioxide	Soft drinks
#375	Sovena Oilseeds Portugal, S.A	Sovena Oilseeds Portugal, S.A	Portugal	Almada	Oilseed processing and vegetable oil refining	Soybeans, sunflower seeds and rapeseeds	Raw vegetable oil and soybean, sunflower and rapeseed flours, biodiesel
#378	Parmalat Portugal - Produtos Alimentares, Lda.	Parmalat Portugal - Produtos Alimentares, Lda.	Portugal	Palmela	Dairies	Raw milk	Pasteurised milk, butter and cream
#379	SCC - Fábrica de Vialonga	SCC–Sociedade Central de Cervejas e Bebidas, S.A.	Portugal	Vila Franca de Xira	Brewing	Water, barley, malt, sugar, carbon dioxide, yeast	Beer and soft drinks
#385	Brewery (Fabrica de bere)	SC European Food SA	Romania	Bihor	Brewing	Hops, corn, water, malt	Beer
#386	SC Agrana Romania SA	SC Agrana Romania SA	Romania	Neamt	Sugar manufacturing	Beet, raw sugar from cane	White sugar
#387	Kallhäll	Arla Foods	Sweden	Stockholm	Dairies	Mainly milk	Fresh milk and cream, fermented milk
#388	Götene	Arla Foods	Sweden	Götene	Dairies	Mainly milk and cream, vegetable oil, cereals and other ingredients	Cheese, butter products, milk powder and cereal-based baby food
#389	Visby	Arla Foods	Sweden	Visby	Dairies	Milk	Milk powder and fresh milk
#390	Linköping	Arla Foods	Sweden	Linköping	Dairies	Mainly milk but also other ingredients	Yoghurt and other fermented products, milk with long shelf life
#393	Malmö Mejeri AB	Skånemejerier AB	Sweden	Malmö	Dairies	Mainly milk and other ingredients	ESL milk, sour milk, yoghurt
#394	Örtofta	Nordic Sugar AB	Sweden	Eslöv	Sugar manufacturing	Sugar beets	Sugar, raw sugar and feed products based on sugar beet

Installation code	Installation name	Company name	Member State	Town	Main FDM sector	Raw materials	Products
#395	Kristianstads Stärkelsefabrik	Lyckeby Starch AB	Sweden	Kristianstad	Starch production	Potatoes	Potato starch, potato fibre, potato protein, concentrated fruit juice
#397	Danish Crown K-Pack AB	Danish Crown K-Pack AB	Sweden	Jönköping	Meat processing	Beef and swine	Beef and swine products
#399	Pivovarna Laško, D.D., PLG	Pivovarna Laško, D.D., PLG	Slovenia	Laško	Brewing	Malt, cereals	Beer, radler, malt drinks, still water in glass, can, keg, PET bottle
#400	Pivovarna Union, D.D., PLG	Pivovarna Union, D.D., PLG	Slovenia	Ljubljana	Brewing	Malt, cereals	Beer, radler, non-alcoholic drinks, still water in glass, can, keg, PET bottle
#401	Bridgwater Dairy (South West England)	Muller Wiseman Dairies	United Kingdom	Bridgwater	Dairies	Raw milk	Liquid milk
#402	Droitwich Dairy (Midlands England)	Muller Wiseman Dairies	United Kingdom	Droitwich Spa	Dairies	Raw milk	Liquid milk
#405	Westbury Dairy (South West England)	Arla Foods	United Kingdom	Westbury	Dairies	Mainly milk	Skimmed milk powder and retail butter
#406	Davidstow Creamery (South West England)	Dairy Crest	United Kingdom	Davidstow	Dairies	Raw milk	Cheese, whey powder
#408	Llandyrnog Dairy (North Wales)	Arla Foods	United Kingdom	Ruthin	Dairies	Mainly milk	Cheese, whey concentrate
#409	Wyke Farms Dairy (South West England)	Wyke Farms	United Kingdom	Bruton	Dairies	Raw milk	Cheese
#412	Bury St Edmunds Sugar Factory (South East England)	British Sugar	United Kingdom	Bury St Edmunds	Sugar manufacturing	Sugar beet	Sugar, animal feed
#413	Cantley Sugar Factory (South East England)	British Sugar	United Kingdom	Norwich	Sugar manufacturing	Sugar beet	Sugar, animal feed

Installation code	Installation name	Company name	Member State	Town	Main FDM sector	Raw materials	Products
#414	Newark Sugar Factory (Midlands England)	British Sugar	United Kingdom	Newark	Sugar manufacturing	Sugar beet, raw sugar	Sugar, animal feed
#415	Wissington Sugar Factory (South East England)	British Sugar	United Kingdom	Kings Lynn	Sugar manufacturing	Sugar beet, sugar juice and syrup	Sugar, animal feed, ethanol, betaine
#416	South Brink factory (South East England)	Nestle Purina Petcare	United Kingdom	Wisbech	Animal feed	Cereals, animal by-products (wet and dry)	Pet food, cans, foil, pouch shelf-stable product
#417	Heineken Manchester, Royal Brewery (North West England)	Heineken UK	United Kingdom	Manchester	Brewing	Malted barley	Beer
#418	Heineken Hereford (Bulmers Cider Mills) (Midlands England)	Heineken UK	United Kingdom	Hereford	Brewing	Apple concentrate	Cider
#419	Trafford Park Starch Refining facility (North West England)	Cargill Plc	United Kingdom	Manchester	Starch production	Wheat	Glucose syrup, vital wheat gluten, starch, bran, ethanol and animal feed products
#422	Carmarthen Feed Mill (South West Wales)	ForFarmers UK Ltd	United Kingdom	Carmarthen	Animal feed	Vegetable-based raw materials (cereals, oilseeds and vegetable by-products from human food industry)	Ruminant feeds
#423	Dungannon Mill (Northern Ireland)	United Feeds Ltd	United Kingdom	Dungannon	Animal feed	Only vegetable origin products. Cereal grains and by-products, oilseeds and by-products, sugar by-products, fruit by-products, vitamins and minerals	Ruminant-only feeds in pelleted and blended meal forms

Installation code	Installation name	Company name	Member State	Town	Main FDM sector	Raw materials	Products
#424	Lancaster Mill (North West England)	Carrs Billington Agriculture (Operations) Ltd	United Kingdom	Lancaster	Animal feed	Cereals, vegetable proteins, molasses, liquid edible oils, minerals, premixtures of additives and trace elements	Ruminant and equine animal feed
#425	Flixborough Mill (North East England)	AB Agri Ltd	United Kingdom	Flixborough	Animal feed	Cereals, vegetable proteins, vegetable oils, fishmeal (< 5 %), minerals, premixtures of additives and trace elements	Bulk poultry feeds
#431	Northampton brewery	Carlsberg UK Ltd	United Kingdom	Northampton	Brewing	Malted barley	Beer
#432	Coronet Mills Manchester	Allied Mills	United Kingdom	Manchester	Grain milling	Wheat	Flour
#433	Chancelot Mill Edinburgh	ADM	United Kingdom	Edinburgh	Grain milling	Wheat	Flour and animal feed pellets
#436	Indulleida S.A.	Indulleida S.A.	Spain	Alguaire (Lleida)	Fruit and vegetables	Fruit and vegetables	Juices, fruit fibres, fruit purées and aromas
#438	Ruskington	Tulip Ltd	United Kingdom	Sleaford	Meat processing	Primarily pork	Fried products (mini sausages, Scotch eggs)
#439	Kings Lynn	Tulip Ltd	United Kingdom	Kings Lynn	Meat processing	Primarily pork	Sliced cooked meats
#440	Bromborough	Tulip Ltd	United Kingdom	Bromborough	Meat processing	Primarily pork	Sausages
#442	Belgomilk - Ysco	Milcobel cvba	Belgium	Langemark	Dairies	Milk	Cheese, butter, milk powder, whey products, ice cream
#450	Aviko Oostrum	Royal Cosun	Netherlands	Venray	Fruit and vegetables	Potatoes	Pre-fried deep-frozen and dried potato products
#453	LWM Kruijningen	Lamb Weston/Meijer	Netherlands	Kruijningen	Fruit and vegetables	Potatoes	Pre-fried deep-frozen potato products and dried flakes

Installation code	Installation name	Company name	Member State	Town	Main FDM sector	Raw materials	Products
#458	Lelystad	McCain	Netherlands	Lelystad	Fruit and vegetables	Potatoes	Pre-fried deep-frozen potato products
#459	Oerlemans Broekhuizenvorst	Oerlemans Foods	Netherlands	Broekhuizenvorst	Fruit and vegetables	Potatoes, vegetables and fruit	Frozen products
#461		Peka Kroef B.V.	Netherlands	Odiliapeel	Fruit and vegetables	Potatoes	Boiled potatoes
#463	Dry pet food plant - Hill's	Hill's pet Nutrition Mfg. BV	Netherlands	Etten-Leur	Animal feed	Processed animal proteins, cereals, oils and fats, vitamins and trace elements	Dry pet food for cats and dogs
#464	Jonker Petfood BV	Jonker Petfood BV	Netherlands	Waalwijk	Animal feed	Meat and meat derivatives, cereals, oils and fats, fish and fish derivatives, derivatives of vegetable origin, milk and milk derivate, vitamin and minerals	Milling, extrusion, drying, coating, cooling
#466	ADM Europort	ADM	Netherlands	Europort	Oilseed processing and vegetable oil refining	Rapeseeds and soybeans	Rapeseed meal, soybean meal, refined rapeseed oil and soybean oil
#468	Kruszwica	Bunge	Poland	Kruszwica	Oilseed processing and vegetable oil refining	Rapeseeds	Rapeseed meal, refined rapeseed oil, bottled oil and margarines
#469	Brzeg	Bunge	Poland	Brzeg	Oilseed processing and vegetable oil refining	Rapeseeds	Rapeseed meal, refined rapeseed oil, bottled oil and margarines
#471	Amerikahaven	Cargill	Netherlands	Amsterdam	Oilseed processing and vegetable oil refining	Crush and refinery sunflower seeds	Meal, crude and refined oil
#473	WEO BV	Wilmar	Netherlands	Rotterdam	Oilseed processing and vegetable oil refining	Crude palm oil, crude coconut oil, crude palm kernel oil	RCNO/RPKO/RPO/PO L56/POL64/PST

Installation code	Installation name	Company name	Member State	Town	Main FDM sector	Raw materials	Products
#474	Rotterdam	IOI Loders Croklaan	Netherlands	Rotterdam	Oilseed processing and vegetable oil refining	Edible oils	Palm oil, palm kernels, coconut and others
#475	Wormerveer	IOI Loders Croklaan	Netherlands	Rotterdam	Oilseed processing and vegetable oil refining	Edible oils	Palm oil, palm kernels, coconut, shea and others
#484	Gain Feeds	Glanbia Plc	Ireland	Portlaoise	Animal feed	Vegetable feed material	Compound feed for pigs and ruminants
#486	Aalst	Tereos-Syral	Belgium	Aalst	Starch production	Wheat	NI
#495	Zoeterwoude	Heineken Nederland Supply	Netherlands	Zoeterwoude	Brewing	Brewery, raw material is malt	Beer

NB: NI = no information provided.
Source: [193, TWG 2015]

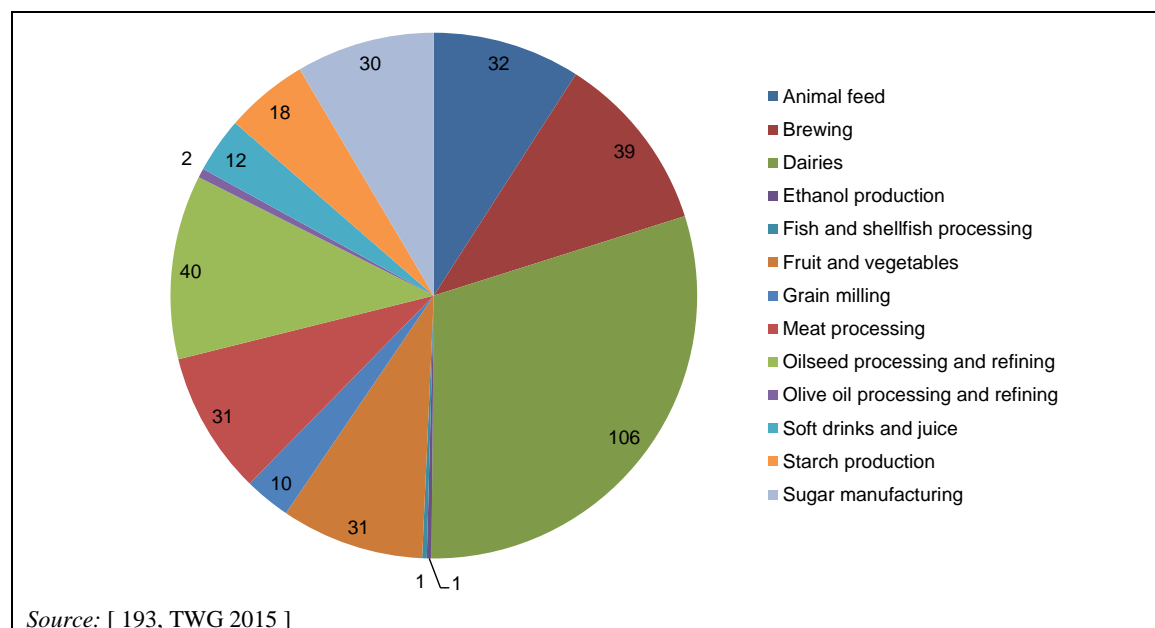

Figure 19.1: Distribution of FDM installations by main FDM sectors

19.2 ANNEX II - Processing techniques and unit operations

19.2.1 Materials reception and preparation

19.2.1.1 Materials handling and storage

Materials handling applies to the receipt, unpacking, storage and internal conveying of raw materials, intermediate products, final products and other outputs, including waste. It is applied in all FDM premises.

Solid materials are commonly delivered in bags stacked on pallets or in containers. They may also be delivered frozen, packed in standardised blocks with carton linings. They are typically transported by forklift trucks and stored in warehouses. Larger amounts of solid raw materials and powders are mostly delivered in bulk. These are offloaded directly for processing or stored in silos for future use. Solid raw materials can be conveyed by water, as is often the case for vegetables, roots and tubers, by air, as is the case for solid particles and powder, or by conveyor belts, elevators, screw conveyors and pumps.

Liquid materials are usually delivered in bulk tankers and then pumped into storage tanks. The internal transport of liquid is achieved by pumping the liquid through pipework systems, which can be extensive and complex. Smaller quantities of liquids are also delivered in mini-bulk containers or in drums. These are then transported to storage areas by forklift trucks.

Gases like N₂, CO₂ and SO₂ are delivered and stored in special pressurised containers. When they are required they are connected to the system concerned and transported through the pipework system by pressure differences. For example, SO₂ is used in the processing of sugar and wine, and N₂ and CO₂ in packing and chilling.

19.2.1.2 Sorting/screening, grading, dehulling, destemming/destalking and trimming

Most raw materials contain some components which are inedible or have variable physical characteristics. Processing techniques such as sorting or screening, grading, dehulling, destemming or destalking and trimming are necessary to obtain the required uniformity of the raw material for further processing. A metal detector may also be used to ensure any metal particles in the raw material are removed. Operations for the removal of stones (e.g. for fruit, olives) and for the elimination of pods (e.g. for peas, beans) can also be performed. These processing techniques are generally used as a first step in the processing of fruit and vegetables. They are also used for meat, egg and fish processing.

Dry and wet sorting or screening is the separation of raw materials and/or slurries into categories on the basis of shape, size, weight, image and colour. Dry sorting is applied in the malting industry to select even-sized grains. Wet sorting is used for slurries, to separate components.

Size sorting and dry cleaning of agricultural raw materials separates solids into two or more fractions. Size sorting is especially important for FDM products which have to be heated or cooled, as large differences in size can lead to the over- or under-processing of the product. For size sorting, various types of screens and sieves, with fixed or variable apertures, can be used. The screens may be stationary, rotating or vibrating. Shape sorting can be carried out manually or mechanically with a belt- or roller-sorter for example. Weight sorting is a very accurate method and is therefore used for more valuable foods, e.g. cut meats, eggs, tropical fruits and certain vegetables. Image processing is used to sort foods on the basis of length, diameter and appearance, i.e. surface defects and orientation of food on a conveyor. Finally, colour sorting of defective discoloured items can be applied at high rates using microprocessor-controlled colour sorters.

Sorting also allows the separation of some additional undesirable material at first sight, e.g. leaves and stones, or inappropriate raw material such as immature or rotten berries, and is aimed at ensuring that only good-quality food is preserved and passed on for further processing.

Grading is the assessment of a number of food characteristics to obtain an indication of their overall quality. The technique is normally carried out by trained operators. Meats for example are examined by inspectors for disease, fat distribution, carcass size and shape. Other graded products include cheese and tea. In some cases, grading is based on laboratory analysis results.

In the wine industry, grading covers the necessary classification of the grapes harvested according to their degree of maturity, e.g. sugar content. Many characteristics cannot be examined automatically and trained operators are employed to simultaneously assess several characteristics to produce a uniform high-quality product. Grading is more expensive than sorting due to the high costs of the skilled personnel required.

Dehulling is the removal of hulls from vegetables and shells from cocoa beans. To remove the shells from cocoa beans, the beans are first broken between adjustable toothed rollers. The broken pieces are subsequently separated in fractions by sieving. Each fraction is treated with a stream of air that carries the light shell pieces away. This breaking and fanning process is often referred to as winnowing.

Dehulling is also used in soybean crushing processes. The dehulling of soybeans is always preceded by a heating step, which enhances the removal of the hulls. The ease of dehulling vegetables depends on the thickness of the seed coat and can be achieved via wet or dry methods. The wet method involves soaking the vegetables in water for a few hours, draining, drying, milling and then blowing them with air to remove the seed coat. In the dry method, oil is mixed with the seeds by passing them through emery-coated rollers to abrade the surface. This is common practice for vegetables with particularly tough seed coats.

Destemming or destalking is the removal of fruit and vegetable stems, e.g. grapes. It is used for winemaking.

Trimming is used for the removal of either inedible parts or parts with defects, or for cutting the raw material to a size that is suitable for further processing. Trimming can be carried out manually or by rotating knives.

19.2.2 Size reduction, mixing and forming

19.2.2.1 Cutting, slicing, chopping, mincing, pulping and pressing

The objective of cutting, slicing, chopping, mincing, pulping and pressing is to reduce the size of material either for further processing or to improve the eating quality or suitability for direct consumption. These operations are widely applied in the FDM sector. For example, they are used in the processing of meat, fish, cheese, vegetables, fruit, potatoes and various crops, e.g. sugar beet. A large variety of equipment is available, normally adapted to the product to be processed. Equipment can be power- or hand-operated, depending on the size of the operations.

Cutting is used for size reduction of large to medium-sized materials. Knives, blades, cleavers or saws are usually used for cutting. Cutting is an important operation in meat and fish processing. The cutting of meat is used post-slaughtering to dress and split carcasses, to remove offal and to remove appendages and is covered in the SA BREF [93, COM 2005]. At meat installations, carcasses are further reduced into retail cuts of joints by the removal of bone, skin and fat. Meat prepared for further processing into, for example, ham, bacon or sausage is initially treated in a similar manner to fresh meat, and will then be subject to further processing operations. These may include deboning, derinding, defatting, slicing, chopping, mincing and emulsifying. The cutting equipment used in meat processing includes power-operated cleavers,

circular or straight saws for splitting carcasses, and band saws for the further reduction of the carcasses. These are all electrically operated. Special derinding machines are used for separating rind and fat from pork. The cutting of potatoes for the production of potato fries often involves the use of hydro cutters where the potatoes are conveyed by water at high speed over fixed blades.

Slicing produces pieces of material of equal thickness. Slicing equipment consists of rotating or reciprocating blades which cut the food when it passes beneath. Sometimes the material is pressed against the blades by centrifugal force. In other cases, e.g. for slicing meat products, the material is held on a carriage as it travels across the blade. Hard fruit, such as apples, are simultaneously sliced and de-cored as they are forced over stationary knives inside a tube. In the sugar industry, sugar beets are cut into thin slices called 'cossettes'.

A variant of slicing is dicing and is applied to meat, fruit and vegetables. In dicing, the food is first sliced and then cut into strips by rotating blades. The strips are passed on to a second set of rotating knives, which operate at right angles to the first set, and cut the strips into cubes.

Chopping breaks down raw materials into small particles. Chopping into a coarse pulp is applied to meat, fruit and vegetables. In chopping, the material is placed in a slowly rotating bowl and subjected to a set of blades rotating at high speed. This technique, also called bowl chopping, is widely used in the production of sausages and similar products. The degree of size reduction can be varied depending on the knife speed and cutting time, and, in extreme cases, the material can be reduced to an emulsion if required.

Mincing is mainly used for the size reduction and homogenisation of meat. A meat grinder is used to mince the meat. This is a lightly constructed screw press with a cutting plate or rotating knives at its outlet. The process is a combination of cutting and extrusion, where the meat is passed through a plate with orifices.

Pulping is mainly used for the size reduction and homogenisation of fruit and vegetables. A moving rough surface ruptures the fruit or vegetables and squeezes the material through a gap producing a homogenised mass. The most common pulpers are drum pulpers and disc pulpers. Sometimes the pulping process is used for juice extraction.

Pressing is applied to extract the liquid part of grapes, other raw materials or marc after maceration. Pressing is used in wine production, for some other alcoholic drinks and for fruit and vegetable juices.

There are two main types of press. The horizontal pneumatic press comprises an inflated pneumatic membrane located in the centre of the press. Berries are slowly pressed releasing the juice, usually known as must in wine-, cider- and perry-making, in a tank, while the solid parts remain in the press. In a hydraulic compression vertical press, grapes are placed in a cage which contains them during the pressing. A horizontal tray presses the grapes vertically and the must which flows through the cage is collected in a tank for further processing. The grapes remain in the cage. There are also other types of presses, e.g. belt presses and horizontal presses.

19.2.2.2 Mixing/blending, homogenisation and conching

The aim of this group of operations is to obtain a uniform mixture of two or more components or to obtain an even particle size distribution in a food material. This can also result in improved characteristics and eating quality. These operations are widely applied in almost all FDM sectors.

Mixing or blending is the combination of different materials. The spatial distribution of the separate components is reduced to obtain a certain degree of homogeneity. Various mixing operations can be distinguished in the FDM sector.

Mixing solids with solids is carried out for example during the production of animal feed, blends of tea and coffee, dried soup, cake mixes, custard, ice cream mixes and malt blends. Mixing equipment commonly used includes rotating drums, rotary mixers, paddle and ribbon mixers and mixing screws in cylindrical or cone-shaped vessels and variable speed drive screws. Generally, cyclones are used as an integral part of the process to recover dust from the extracted air. The recovered material is then reprocessed.

Mixing solids with liquids is carried out for example during the production of canned foods and dairy products. This type of mixing is also used in the production of chocolates and sweets for example, where the ingredients are mixed in a more or less liquid state and solidify on cooling. For viscous mixtures, kneading machines are used. For low-viscosity mixtures, various types of stirrers, impellers and agitators are used.

Mixing liquids with liquids is carried out for example during the production of emulsions like mayonnaise, margarine and mixtures of solutions. This type of mixing is also used to blend different wines or mineral water with each other or with additives or extra ingredients. Various types of stirrers, impellers and agitators are used.

Finally, mixing liquid with gas is carried out for example when making ice cream, whipped cream and some sweets. During spray drying, the liquid phase is mixed in a stream of gas. Atomisers are used to produce small liquid droplets, which are brought into contact with a stream of gas. When making ice cream, whipped cream or a foam, small gas bubbles are fed into a liquid.

The aim of homogenisation is to attain a more even particle size or a more homogeneous blend of materials. It is applied, for example, to whole milk to reduce the size of fat globules so that they stay evenly divided in the milk, thereby preventing the fat separating and the cream rising. The liquid, i.e. whole milk, is pressed under high pressure, 200–300 bar, through a small orifice.

Conching is a special method of kneading used in the chocolate industry. The molten chocolate mass is placed in a special trough-shaped vessel and is kneaded by a granite roller moving slowly back and forth. The aim of conching is to reduce the viscosity of the mass and to improve the flavour and the texture.

19.2.2.3 Grinding/milling and crushing

Grinding or milling is used for the size reduction of solid dry material. It may also improve the eating quality and/or suitability of the material for further processing. It is the main process in the cereal and animal feed industry and is also used to crush cane sugar and to facilitate the extraction of sugar in sugar and rum factories. Crushing covers, for instance, breaking the skin of berries and grapes to liberate the must.

Grinding or milling is applied where dry solid materials are processed, e.g. in the flour milling, animal feed, semolina, brewing, sugar and dairy sectors. Crushing is necessary to facilitate the yeasts' multiplication and also to conduct traditional macerations before pressing, e.g. in winemaking.

A whole range of grinding or milling techniques and equipment are available for application with different types of food. It can be carried out dry or wet. In wet grinding or milling, smaller particle sizes can be attained. Often the dry technique is combined with sieving or air classification, which results in particle size fractions. Generally abatement systems, e.g. cyclones, are used as an integral part of the process, to recover dust from the extracted air. The recovered material is then reprocessed.

The common types of mills used in the FDM sector are hammer mills, ball mills, roller mills and disc mills. A hammer mill consists of a horizontal or vertical cylindrical chamber lined with

a steel breaker plate and contains a high-speed rotor fitted with hammers along its length. The material is broken apart by impact forces as the hammers drive it against the breaker plate. A ball mill consists of a slowly rotating horizontal steel cylinder, half-filled with steel balls of 2.5 – 15 cm in diameter. The final particle size depends on the speed of rotation and on the size of the balls. A roller mill consists of two or more steel rollers which revolve towards each other and pull particles of the food material through the space between the rollers; the space is known as the nip. The size of the nip can be adjusted for different food materials. A disc mill consists of either a single rotating disc in a stationary casing or two discs rotating in opposite directions. The food material passes through the adjustable gap between the disc and the casing or between the discs. Disc mills have intermeshing pins fixed onto the discs and casing. This improves the effectiveness of the milling.

19.2.3 Separation techniques

19.2.3.1 Extraction

The objective of extraction is to recover valuable soluble components from raw materials by primarily dissolving them in a liquid solvent, so that the components can be separated and recovered later from the liquid. It is not always the objective to recover one particular compound in pure form from a raw material, i.e. sometimes extraction is intended to separate all of the soluble compounds from the residue; an example of this is the extraction of coffee.

Extraction is widely applied in the FDM sector. Examples include the extraction of sugar from sugar beets or sugar cane, oil from oilseeds and from virgin pomace, coffee extract from coffee beans, caffeine from coffee beans and various other compounds such as proteins, pectins, vitamins, pigments, essential oils, aroma compounds and flavour compounds from many different materials.

Extraction works according to the principle that soluble components can be separated from insoluble or less soluble components by dissolving them in a suitable solvent. Raw materials that are suitable for extraction may contain either solids only, solids and a solution, or solids and a liquid. Solid/liquid extraction is sometimes called leaching. When the soluble component is incorporated in a liquid, the extraction may be applied to recover the valuable soluble component. Commonly, the extract is the product or intermediate product and the residue is a waste or by-product. The efficiency of the extraction process depends on the selectivity of the solvent. Common solvents include water, organic solvents such as hexane, methylene chloride, ethyl acetate and alcohol. Supercritical CO₂ is used in coffee extraction.

Raw materials are usually pretreated to ensure efficient extraction of the desired compounds. For example, sugar beets and sugar cane are cut into thin slices, nuts and seeds are ground or flaked, coffee beans are roasted and ground, and tea leaves are dried and ground.

The simplest extraction method is a repeated extraction with fresh solvent called lateral flow extraction. However, this is rarely used because of the costs of the solvent and because it results in a very low-concentration extract. The most common method used is countercurrent extraction, either in a batch or continuous process. Batch-wise countercurrent extraction is normally only used for the processing of small amounts of material. In continuously operating extractors, the solid material and the solvent flow countercurrently. One difficulty with extraction is the recovery of the extracted material from the solvent. This can be carried out by evaporation, crystallisation, distillation or steam stripping.

In principle, many different methods of transport are possible for material and liquid flows. Some examples of commonly used transport systems include perforated trays connected to an unbroken conveyor or loop, moving horizontally or vertically; screw conveyors which transport the solid material in a countercurrent flow vertically or upwards under an incline slope, the screws are perforated to obtain a uniform flow of liquid; and, finally, an unbroken perforated belt where the solvent is circulated under pump action and sprayed on top of the solid material.

19.2.3.2 Centrifugation

Centrifugation is used to separate immiscible liquids and solids from liquids. Separation is carried out by the application of either centrifugal forces or natural gravity.

This technique is typically used in the dairy industry in the clarification of milk, the skimming of milk and whey, the concentration of cream, the production and recovery of casein, in the cheese industry, and in lactose and whey protein processing. It is also used in drink technology, the production of vegetable and fruit juices, coffee, tea, beer, wine and soya milk, oil and fat processing/recovery, cocoa butter manufacturing, sugar manufacturing and waste water treatment.

Centrifugation is used to separate mixtures of two or more phases, one of which is a continuous phase. There are two general ways to operate centrifuges: continuous systems and systems with breaks for cleaning. In continuous systems, the sludge can be discharged during the process. The driving force behind the separation is the difference in density between the phases. By using centrifugal forces, the separation process is accelerated. The necessary centrifugal forces are generated by rotating the materials. The force generated depends on the speed and radius of rotation. In raw milk for example, the skimmed milk is the continuous phase, the fat phase is a discontinuous phase formed of fat globules with diameters of some microns, and a third phase consists of solid particles. In beer production, clarification of the hot wort is carried out to remove hot trub particles to get a clear wort. The commonly used equipment for wort clarification is the hydrocyclone, where wort trub particles are separated in a tangential flow.

Centrifuges are classified into four groups:

- tubular and disc bowl centrifuges;
- solid bowl and nozzle or valve discharge centrifuges;
- conveyor bowl, reciprocating conveyor and basket centrifuges;
- hydrocyclones or whirlpools.

A tubular bowl centrifuge consists of a vertical cylinder, which rotates at 15 000–50 000 rpm, inside a stationary casing. It is used to separate immiscible liquids, e.g. vegetable oil and water or solids from liquid. The two components are separated into annular layers, with the denser liquid or solid settling nearer to the bowl wall. The two layers are then discharged separately. Typically, the disc bowl centrifuge is more widely used in the FDM sector as it can achieve a better separation due to the thinner layers of liquid formed. The cylindrical bowl contains inverted cones or discs and the liquids only have to travel a short distance to achieve separation. These centrifuges operate at 2 000–7 000 rpm and have capacities of up to 150 000 l/h. Disc bowl centrifuges are used to separate cream from milk; to clarify oils, coffee extracts and juices; or to separate starch from slurry.

A solid bowl centrifuge is the simplest solids/liquid centrifuge and is useful when small amounts of solids are removed from large volumes of liquid. It consists of a rotating cylindrical bowl. Liquor is fed into the bowl; the solids settle out against the bowl wall whilst the liquid spills over the top of the bowl. Cakes can also be removed without stopping the centrifuge. Liquors containing higher levels of solids, i.e. > 3 wt-%, can be separated using nozzle or valve discharge centrifuges. These centrifuges are a modified disc bowl centrifuge with a double conical bowl which enables the automatic discharge of solids. These types of centrifuges are used to treat oils, juices, beers and starches to recover solid parts, e.g. yeast cells. They have capacities of up to 300 000 l/h. A special type is the bacto-fuge, which is a high-speed centrifugal process which separates bacterial cells and spores from milk.

The conveyor bowl or decanter, reciprocating conveyor and basket centrifuges are used when the feed contains high levels of solids or sludges. They are used to recover animal protein, e.g. precipitated casein from skimmed milk, and vegetable proteins, to separate coffee, cocoa and tea slurries and to remove sludge from oils. In the conveyor bowl centrifuge, the solid bowl rotates

25 rpm faster than the screw conveyor. This causes the solids to be conveyed to one end of the centrifuge whereas the liquid fraction moves to the other larger-diameter end. The reciprocating conveyor centrifuge is used to separate fragile solids, e.g. crystals from liquor.

The feed enters a rotating basket through a funnel, which rotates at the same speed. This gradually accelerates the liquid to the bowl speed and thus minimises shear forces. Liquid passes through perforations in the bowl wall. When the layer of solids has built up, it is pushed forward by a reciprocating arm. The basket centrifuge has a perforated basket lined with a filtering medium, which rotates at 2 000 rpm. Separation occurs in cycles, which last from 5 to 30 minutes. In the three stages of the cycle, the feed liquor first enters the slowly rotating bowl, the speed is then increased and separation takes place; finally, the speed of the bowl is reduced and the cake is discharged through the base. Capacities are up to 90 000 l/h.

A typical hydrocyclone comprises a conical section terminating in a cylindrical section. The hydrocyclone is fitted with a tangential inlet and closed with an end plate, with an axially mounted overflow pipe or vortex finder. The end of the conical portion terminates in a circular apex opening. During operation, the slurry is forced, under pump pressure, through the tangential inlet and this produces a strong swirling motion. The fraction of the slurry contains the lighter particles discharged through the overflow, and the remaining slurry and solids are discharged through the underflow opening.

19.2.3.3 Filtration

Filtration is the separation of solids from a suspension in a liquid by means of a porous medium, screen or filter cloth, which retains the solids and allows the liquid to pass through. Air filtration is discussed in Sections 2.3.7.2.2 and 2.3.7.2.5.

Filtration is used in the FDM sector to clarify liquid products by the removal of small amounts of solid particles with the subsequent recovery of the filtrate, e.g. for wine, beer, oils and syrups, and to separate a liquid from a significant quantity of solid material to obtain the filtrate or cake, or both, e.g. for fruit juices or beer. The technique operates either by pressure filtration, i.e. applying pressure to the feed side, or by vacuum filtration, i.e. applying a vacuum to the filtrate side.

The two main types of pressure filtration are the plate and frame filter press and the leaf filter.

The plate and frame filter press consists of plates and frames arranged alternately and supported on a pair of rails. The hollow frame is separated from the plate by the filter cloth. The slurry is pumped through a port in each frame and the filtrate passes through the cloth and flows down the grooved surfaces of the plates and is drained through an outlet channel in the base of each plate. The filter operates at a pressure of between 250 kPa to 800 kPa. The filter press is operated batch-wise; the optimum cycle time depends on the resistance offered by the filter cake and the time taken to dismantle and refit the press. This press can be used when the dismantling, emptying and refitting of the presses are carried out in a semi-automatic manner. Sometimes, filter aids such as perlite or diatomaceous earth are used as a precoat or body feed to improve the filtration. The equipment is reliable and easily maintained, and is widely used, particularly for the production of apple juice and cider and in edible oil refining. A special type of plate and frame filter press is the membrane filter press. A membrane is mounted onto the plate which can be pressurised with air or water. Due to the higher pressure on the filter cake, up to 20 bar, more liquid is recovered, resulting in a dryer filter cake.

The need to develop much larger capacity units led to the introduction of the leaf filters. These consist of mesh leaves which are coated in filter medium and supported on a hollow frame, which forms the outlet channel for the filtrate. The leaves can be stacked horizontally or vertically. Feed liquor is pumped into the shell at a pressure of approximately 400 kPa. When the filtration is completed, the solid residue is blown or washed from the leaves.

Vacuum filters are normally operated continuously. Liquor is sucked through the filter plate or cloth and the solids are deposited on the cloth. The pressure difference on the downstream side of the filter plate is normally limited to 100 kPa due to the cost of vacuum generation. Sometimes, filter aids are used as a precoat or body feed to improve filtration. In these cases, a knife is used to scrape off the solid residue. Two common types of vacuum filter are the rotary drum filter and the rotary vacuum disc filter.

Rotary drum filters consist of a slowly rotating cylinder, which is divided into compartments, which are themselves covered with a filter cloth and connected to a central vacuum pump. As the drum rotates, it dips into a bath of liquor. The filtrate flows through the filter cloth of the immersed compartment. When the compartment leaves the bath, the filter cake is sucked free of liquor and washed. As the drum rotates further, the vacuum is released for the compartment in question and the cake is loosened from the cloth by the application of compressed air, and then removed by means of a scraper. The same procedure occurs for each compartment in turn as the cycle is repeated.

Rotary vacuum disc filters consist of a series of vertical discs which rotate slowly in a bath of liquor in a similar cycle to drum filters. Each disc is divided into segments and each segment has an outlet to a central shaft. The discs are fitted with scrapers to continuously remove the solid residue.

19.2.4 Heat processing

19.2.4.1 Cooking and boiling

Several processing techniques are available for cooking within the FDM sector.

Cooking and boiling are heat-processing techniques applied to foodstuffs, principally to make the food edible. They also alter the texture, colour and moisture content of the food and may facilitate other later processes.

Cooking and boiling are applied on an industrial scale for the preparation of ready-to-eat meals, in the preparation of complete meals and for meal components, such as in various meat products. They are also applied to heat foodstuffs prior to final processing.

Cooking is carried out in ovens. There are several different types of ovens: water bath, shower, steam, hot air and microwave.

Water bath ovens allow the best homogeneity of heating to be obtained. The immersion in hot water causes weight loss and results in proteins and greases being released into the water. Boiling is cooking in a water bath oven at boiling temperature.

Shower ovens allow a good uniformity of heating. They include the simultaneous action of water sent through the showers and the saturated steam which rises from the collecting basin, at the bottom of the oven, which is heated, in turn, by coils.

In steam ovens, the water shower is eliminated and any heating is only due to the steam produced in the collection basin.

Hot air ovens include, when it is necessary to control surface humidity, a steam inlet and a recirculation of hot air which is obtained by passage through heat exchangers.

In a microwave oven, food is heated by passing microwaves through it; the resulting generation of heat inside the food facilitates rapid cooking.

19.2.4.2 Pasteurisation, sterilisation and UHT treatment

The conservation of food and feed products is achieved by the killing of the microorganisms present. Heat treatment for the conservation of products is one of the main techniques used in the FDM sector. Heat treatment stops bacterial and enzyme activity and so prevents loss of quality and reduces food perishability. In heat treatment processes, various time/temperature combinations can be applied, depending on the product properties and shelf-life requirements.

Pasteurisation and sterilisation are used to treat all types of FDM products; these include milk, juices and beer. UHT treatment is applicable to low-viscosity liquid products.

Pasteurisation is a controlled heating process used to eliminate viable forms of any microorganism, i.e. pathogen or spoilage-causing, that may be present in milk, fruit-based drinks, some meat products, and other foods, or to extend shelf life as is the case with beer. A similar controlled heating process, referred to as blanching, is used in the processing of fruit and vegetables. Both pasteurisation and blanching are based on the use of the minimum heat requirement needed to deactivate specific microorganisms or enzymes, thus minimising any quality changes in the foods themselves [87, EC 1999]. In pasteurisation, generally a heating temperature below 100 °C is applied.

Sterilisation is a controlled heating process used to eliminate viable forms and spores of any microorganism, i.e. pathogen or spoilage-causing, that may be present in a preserved food. This can be achieved by moist heat, filtration, radiation or by chemical methods. Compared to pasteurisation, a heat treatment of over 100 °C is applied for a period long enough to lead to a stable product shelf life.

UHT treatment is a heat treatment of over 100 °C for a very short time.

Pasteurisation temperatures commonly range from 62 °C to 90 °C, and pasteurisation times vary from seconds to minutes. Batch-wise pasteurisation uses a temperature of 62–65 °C for up to 30 minutes. High-temperature short-time (HTST) pasteurisation uses a temperature of 72–75 °C for 15 to 240 seconds. High-heat short-time pasteurisation (HHST) applies a temperature of 85–90 °C for 1 to 25 seconds.

Batch-wise pasteurisation is carried out in agitated vessels. Sometimes the product, i.e. beer and fruit juices, is pasteurised after bottling or canning. Here the products in their containers are immersed in hot water or fed through a steam tunnel. For continuous pasteurisation, flow-through heat exchangers, e.g. tubular, plate and frame, are applied. These have heating, holding and cooling sections. Table 19.2 shows examples of heat treatment combinations used in the FDM sector.

Table 19.2: Examples of heat treatment combinations used in the FDM sector

Process	Heating temperature/ holding time	Use
Bulk liquid pasteurisation	63 °C/30 min	Vat pasteurisation of milk
High-temperature short-time pasteurisation (HTST)	72 °C/15 s	Continuous pasteurisation of milk for food safety
Cooking of meat products	65–75 °C internal temperature	Ready-to-eat products, e.g. ham, meat loaves and frankfurters
Blanching of vegetables	Variable, e.g. 75 °C/5 min	Enzyme deactivation and tissue softening
In-bottle pasteurisation	60 °C/10 min*	Extension of beer shelf life
* The parameter may vary depending on the type of beer. Source: [1, CIAA 2002]		

Generally for sterilisation, the product is canned or bottled and then heat-treated in a steriliser with steam or hot water. Sterilisers may be batch or continuous. In sterilisation with moist heat, temperatures generally range from 110 °C to 130 °C with sterilisation times being from 10 to 120 minutes. Higher temperatures and shorter times may have similar effects, e.g. 134 °C for 3 minutes. However, if conditions do not allow the germination of spores, lower temperatures and shorter times can also be applied. For example, with acid fruit juices, jam or desserts, heating up to 80–100 °C for 10 minutes is normally sufficient.

Solutions containing thermolabile compounds can be sterilised by filtration through mediums such as nitrocellulose membranes, diatomaceous earth, e.g. kieselguhr, and porcelain. UV radiation is used to keep rooms partially sterile. Bacteria and their spores are killed quickly, but fungal spores are only moderately sensitive to radiation. Ionising radiation, e.g. X-ray and gamma radiation, is used to sterilise food and other compact materials. Chemical means may also be applied. Ethylene oxide is used to sterilise food, plastics, glassware and other equipment [87, EC 1999].

UHT treatment means a very short heat treatment at temperatures of 135–150 °C for only a few seconds. This results in a sterilised product with minimal heat damage to the product properties. UHT treatment is only possible in flow-through equipment. The product is thus sterilised before it is transferred to pre-sterilised containers in a sterile atmosphere. This requires aseptic processing. For UHT treatment, indirect heating in plate and frame or tubular heat exchangers is applied. Direct steam injection or steam infusion may also be applied.

19.2.5 Concentration by heat

19.2.5.1 Evaporation (liquid to liquid)

Evaporation is the partial removal of water from liquid food by boiling. For instance, liquid products can be concentrated from 5 % dry solids to 72 %, or even higher, depending on the viscosity of the concentrates. Evaporation is used to pre-concentrate food, to increase the solid content of food, to change the colour of food and to reduce the water content of a liquid product almost completely, e.g. as in edible oil drying.

Evaporation is used in many FDM sectors. For example, it is used to process milk, starch derivatives, coffee, fruit juices, vegetable pastes and concentrates, seasonings, sauces, sugar, ethanol and edible oil.

Steam, vapour, or exhaust gases from other drying operations are usually used as the heating medium. The latent heat of condensation is transferred to the liquid food to raise its temperature to boiling point, to evaporate the water. The vapour is then removed from the surface of the boiling liquid. Since food products are heat-sensitive, it is often necessary to work at low temperatures. This is achieved by boiling the liquid part under vacuum. Evaporation normally occurs in the range of 50 °C to 100 °C, although it can be as high as 130 °C in the sugar industry.

In its simplest form, evaporation is carried out by boiling off water to the air, using immersed electric heaters. However, in practice the most commonly used equipment is multistage shell and tube evaporators, or plate evaporators. Shell and tube evaporators may be natural or forced circulation, climbing or falling film types. Centritherm evaporators, wiped film evaporators (WFE), thin film evaporators and vacuum pans are specially designed for the evaporation of highly viscous products. Typical total solids concentrations for various types of evaporators are shown in Table 19.3. The emission level of total solids in the outlet depends on the composition of the product to be concentrated.

Table 19.3: Typical total solids concentrations for various types of evaporators

Evaporator type	Total solids inlet (%)	Total solids outlet (%)
Shell and tubes, multistage	5–25	40–75
Plates, multistage	5–25	40–75
Vacuum pans	60–70	80–85
Centritherm, single-stage	5–25	40–60
WFE, single-stage	40–50	70–90
<i>Source: [1, CIAA 2002]</i>		

Multiple-effect evaporators are used when evaporation requires significant energy, e.g. in sugar beet processing, starch production and the evaporation of milk and whey. These evaporators use fresh steam or exhaust gases from other operations, and so recover or reuse energy, to boil off water vapour from the liquid in the first effect. The evaporated water still has sufficient energy to be the heat source for the next effect, and so on. A vacuum is applied in a multiple-effect series to allow the water to boil off. The liquid being processed is passed from one evaporator body through the others so it is subjected to multiple stages of evaporation. In this way, one unit of steam injected in the first evaporator can remove three to six units of water from the liquid.

Additional energy can be saved by recompressing the vapour using a thermal vapour recompressor (TVR) or a mechanical vapour recompressor (MVR). However, this can lead to steam contamination, making it unsuitable for return to the boilers and therefore increasing the waste water load. In the final stage, the vapour may be condensed by cooling with cooling water. Some of the vapours can be drawn off the evaporators to be used as heat sources for other process requirements. The condensate may be of such a quality that it may even be fed to other processes as process water.

During processing, product compounds gradually deposit on the heat-exchange surfaces. This can affect the efficiency of the heat exchange and lead to heat losses in the system. These deposits may be inorganic or organic, depending on the product. The installation is therefore cleaned at regular intervals to prevent too high a heat loss occurring with a subsequent loss of product quality.

The removal of deposits during cleaning and product losses during start-ups and shutdowns contributes to the organic and inorganic load in the waste water. During evaporation, condensates from the product are also produced. Depending on their content, e.g. organic, inorganic and TSS, these condensates can be reused in the process or are treated in a WWTP. The final vapours are condensed in an open or closed condenser using cooling water. The waste water contains dissolved organic and inorganic matter and TSS.

Sometimes non-condensable gases are vented to the air to ensure efficient heat transfer. The environmental effects arising depend on the gases being vented. Dust and odour may also be a problem.

Steam requirements for single-stage evaporators range from 1.1 tonnes to 1.2 tonnes of steam per tonne of evaporated water. Energy requirements may be reduced when using multi-effect evaporators. In the case of double or third effect, the steam requirement lowers respectively to 0.6–0.7 tonnes and 0.4 tonnes of steam per tonne of evaporated water. The steam consumption can also be reduced by applying mechanical or thermal vapour recompression. Sometimes exhaust gases can be used to recover energy from other processes such as drying.

Drying and evaporation are often the main energy-using processes within the FDM sector. In some existing installations, complex combinations of different techniques are applied for various individual unit operations. Evaporation is widely applied to increase the solids content of liquids. Sometimes this is done as a preliminary step before drying and can be achieved using a wide variety of techniques. Theoretically, for the evaporation of water 0.611 kWh/kg (2.2 MJ/kg) is required. In practice, this very much depends on the method of evaporation and the type of dryer used and it can range from 0.556 kWh/kg to 0.972 kWh/kg (2.0 MJ/kg to 3.5 MJ/kg). The energy consumption for drying can be less if the dry substance content of the

wet material is higher. This can be achieved by pre-evaporation or by using special dewatering equipment such as presses or centrifuges. Steam dryers can have considerably lower energy consumption if they consist of more stages (see Section 5.4.2.8). Sometimes exhaust gases from combustion CHP equipment are used to dry the products, thereby reducing the energy requirement.

Falling film evaporators can be used for single- and multistage evaporation. These are long tubular structures made from stainless steel. Liquid is introduced at the top of the evaporator and flows as a thin film down the inside surface of heated tubes or plates which are packed into the evaporator. The principle of falling film evaporation is shown in Figure 19.2.

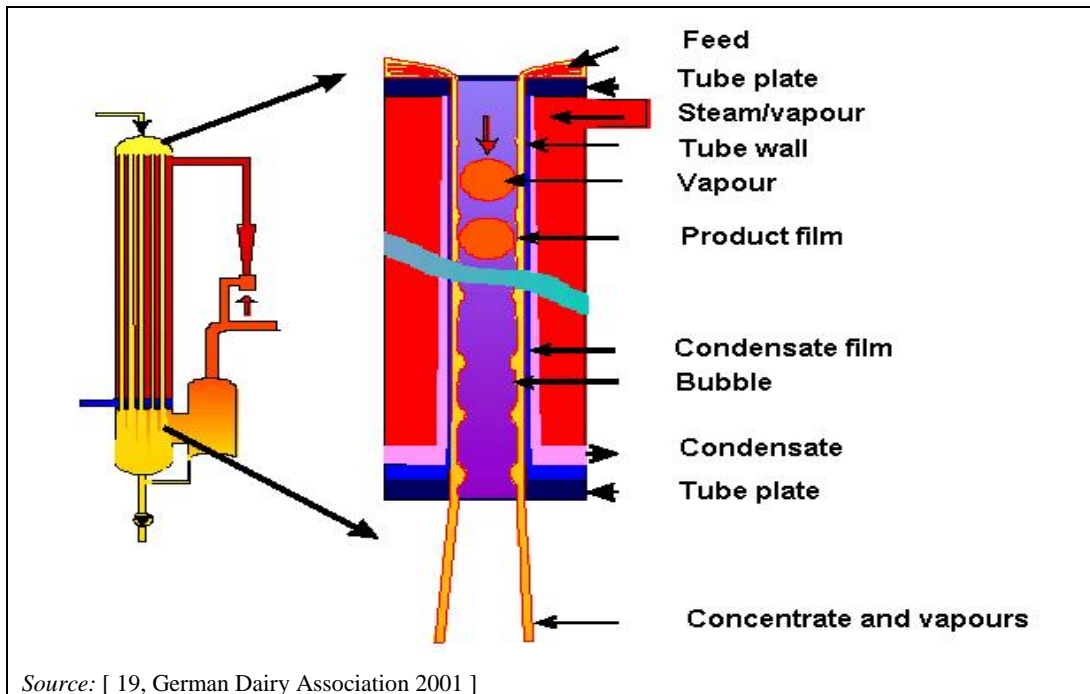

Figure 19.2: The principle of falling film evaporation

The outline of an evaporating system is shown in Figure 19.3.

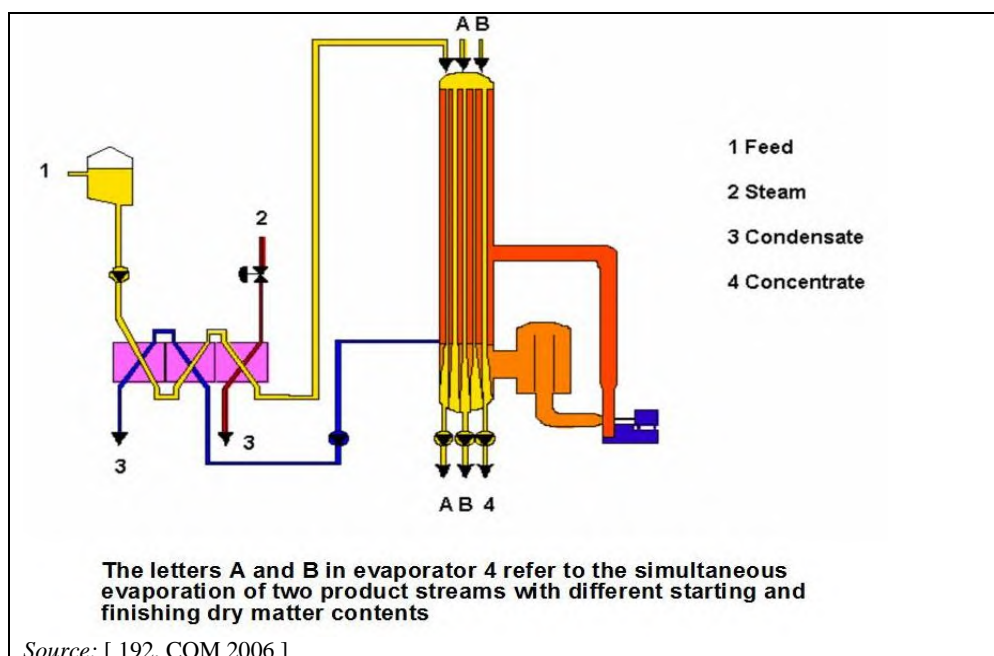

Figure 19.3: Milk evaporation using a falling film

Vapour compression/recompression

By compressing exhaust vapours, it is possible to make major cuts in energy requirements for concentration processes in the FDM sector. For example, in wort boiling in breweries, the water vapour is given off when a solution is concentrated by condensation. The heat which is put in to evaporate the water and concentrate the solution can be recovered by condensing the vapour that is driven off. Some common types of compressors used are rotary compressors, screw compressors, radial-flow turbo compressors and blowers.

To enable the heat of condensation stored in the vapour to be used to provide additional heat for the concentration process, condensation of the vapour takes place at a temperature higher than the boiling point. To raise the condensation temperature, the vapour is compressed by 0.1–0.5 bar (0.1–0.5 hPa). A heat exchanger is then used to return the heat of condensation from the compressed vapour to the concentration unit.

Apart from the energy needed to drive the compressor, no further energy input is required. The ratio of recovered energy to energy input, i.e. the performance figure, may be as high as 40. In addition to saving energy and reducing energy costs, another important reason for condensing vapours is to reduce odour emissions.

The feasibility of installing vapour-compressing techniques greatly depends on the investment costs and the payback time due to lower operating costs. Different and changing energy costs in different countries may also influence the decision. In some sectors, operation is seasonal, e.g. 50 days for tomatoes, and therefore the length of the campaign is also an important factor.

19.2.5.2 Dehydration (solid to solid)

Dehydration is defined as the application of heat under controlled conditions to remove, by evaporation, the water present in solid foods or by-products from agricultural raw material processing. The main purpose of dehydration is to extend the shelf life of foods by reducing their a_w .

Some examples of dried foods are dried potatoes, starch derivatives, sugar beet pulp, flour, pasta, beans, fruit, nuts, cereals, oilseed meals, tea leaves, vegetables and spices. The dehydration of wet germinated grain is applied in the production of malt which is also called kilning. For the malting process, the drying step is essential and is required to create the desired colour and flavour.

Dehydration affects food texture and colour and causes the loss of volatile components, all of which have a detrimental effect on both the quality and the nutritional value of the food. The design and operation of dehydration equipment aims to minimise these changes by selecting appropriate drying conditions for individual foods. For dehydration, the two different principles are hot air drying and surface drying by heat conduction through a heat transfer system.

Various types of dryers are used, i.e. fluidised bed, cabinet or tray, conveyor or belt, pneumatic, flash and/or ring, rotary, tunnel, steam bundle, steam, kiln and vacuum dryers.

FBDs are composed of metal trays with mesh or perforated bases that can contain a bed of particulate foods up to 15 cm deep. Hot air is blown through the bed, causing the food to become suspended and then vigorously agitated. The air acts as both the drying and the fluidising medium. They can be batch or continuously operated. FBDs are compact and allow good control of the drying conditions and relatively high thermal efficiencies and high drying rates. These dryers have very high rates of heat and mass transfer and consequently short drying times. Drying can take place with air temperatures below 100 °C, but may also be up to 170 °C or higher depending on the product/process. A FBD is often applied as a last drying step after spray drying in the dairy industry.

Cabinet or tray dryers consist of an insulated cabinet fitted with a shallow mesh or perforated trays, each of which contains a thin layer of food. Hot air is circulated through the cabinet. A system of ducts and baffles are used to direct air over and/or through each tray to promote a uniform air distribution. These dryers are used for small-scale production and have low capital and maintenance costs. They are relatively difficult to control and produce variable product quality.

Continuous conveyor or belt dryers are up to 20 metres long and 3 metres wide. The food is dried on a mesh belt. The airflow is initially directed upwards through the bed of food and then downwards in later stages to prevent dried food from blowing out of the bed.

In pneumatic, flash and/or ring dryers, powders or particulate foods are continuously dried in vertical or horizontal metal ducts. A cyclone separator or a bag filter is used to remove the dried product. The moist food is metered into the ducting and suspended in hot air. They have relatively low capital costs, high drying rates and thermal efficiencies, and good control over the drying conditions.

Rotary dryers are slightly inclined rotating metal cylinders fitted internally with flights that cause the food to cascade through a stream of hot air as it moves through the dryer. Airflow may be parallel or countercurrent. The agitation of the food and the large area of food exposed to the air produces high drying rates and a uniformly dried product. The method is especially suitable for foods that tend to mat or stick together in belt or tray dryers. It is used on a large scale in the sugar industry for sugar and beet pulp drying. In the case of pulp, exhaust gases from the combustion plant may be used as a heat source when the physical plant and the hot gas temperature allows. Some combustion plants can produce hot gas temperatures of around 120 °C.

In tunnel dryers, thin layers of food are dried on trays, which are stacked on trucks programmed to move semi-continuously through an insulated tunnel in which hot air is circulated.

In steam bundle dryers, the heating medium or steam is not in contact with the wet product. A heat transfer surface is used to transfer the heat to the product's surface for drying. The steam passes through the dryer, through cylindrical tubes/bundles which rotate, to avoid local overheating and to improve uniform drying. This dryer uses less air volume and subsequently emissions into the air are limited.

Steam drying is a special dryer design that uses superheated steam produced via a heat exchanger. The dryer consists of a pressure vessel in which the water from the product is driven off, turned into steam and then used to dry more product. This system is used in the sugar industry, on a limited scale, for drying beet pulp. One advantage is the low energy consumption for drying.

Drying in kilns is used for malting which is described in Section 16.9.

Vacuum drying is used for heat-sensitive products. The external pressure is lowered to avoid drying at a high temperature. One simple type of vacuum drying is vacuum roller drying. In this method, either one or two rollers are installed in a vacuum housing. The resulting vapour precipitates in a condenser located between the vacuum chamber and the pump. The product is removed by a screw conveyor.

In the hot-air dehydration process, air, with water vapour containing VOC and dust, is released. If dehydration is carried out using directly fired burners, the exhaust gases might also contain CO₂, CO, SO₂ and NO_x, depending on the heat source and burner type. Depending on the type of raw material or product, the dust may be glutinous and wet, e.g. meal from oilseed processing. Dry dust can be filtered and wet dust can be recovered using cyclones. Odour may also be a problem.

19.2.6 Processing by the removal of heat

19.2.6.1 Freezing

Freezing is a preservation method. In freezing, the temperature of a food is reduced to below the freezing point and a proportion of the water undergoes a change in state to form ice crystals. The sector standard for freezing food is to reduce the temperature to around $-18\text{ }^{\circ}\text{C}$. Several types of food can be frozen, e.g. fruit, vegetables, fish, meat, baked goods and prepared foods such as ice cream and pizzas.

During freezing, the heat is first removed to lower the temperature of the food to the freezing point. This includes removal of heat produced by respiration as in fresh foods. The latent heat of crystallisation is then removed and ice crystals are formed. Table 19.4 shows the typical freezing points of various FDM products.

Table 19.4: Typical freezing points of various FDM products

FDM product	Freezing point
Meat	$-2.0\text{ }^{\circ}\text{C}$
Poultry	$-2.2\text{ to }-2.5\text{ }^{\circ}\text{C}$
Fish	$-2.2\text{ to }-0.5\text{ }^{\circ}\text{C}$
Vegetables, e.g. peas, cauliflowers, onions, carrots and tomatoes	$-0.9\text{ to }-1.4\text{ }^{\circ}\text{C}$
Fruit, e.g. pears, plums and apricots	$-1.8\text{ to }-2.5\text{ }^{\circ}\text{C}$
Berry fruits, e.g. strawberries and raspberries	$-0.8\text{ to }-1.2\text{ }^{\circ}\text{C}$
Milk	$-0.5\text{ }^{\circ}\text{C}$
Ice cream	$-4.0\text{ to }-6.0\text{ }^{\circ}\text{C}$
<i>Source: [18, Environment Agency of England and Wales 2000]</i>	

A whole range of methods and equipment for freezing foods is available. The most common freezers used are blast, belt, fluidised bed, cooled surface, immersion and cryogenic freezers. Cryo-extraction and concentration by cold are also used.

In blast freezers, cold air at $-30\text{ }^{\circ}\text{C}$ to $-40\text{ }^{\circ}\text{C}$ is circulated over the food at a velocity of 1.5–6 m/s. In batch blast freezers, the food is stacked on trays in rooms or cabinets. In continuous equipment, trays covered with food are stacked on trolleys or the food is moved through a freezing tunnel by conveyor belts. Sometimes multiphase tunnels are applied with a number of belts. The product falls from one belt onto another; this also breaks up clumps of frozen food. The thickness of the food layer on the belts can vary from 25 mm to 125 mm. In blast freezers, large volumes of air are recycled. However, this can cause freezer burn and oxidative changes to unpackaged food. Moisture from the food is transferred, via the air, to the refrigeration coils, which makes frequent defrosting necessary. Impingement freezing and cooling with air velocities of up to 45 m/s and down to $-50\text{ }^{\circ}\text{C}$ is also applied.

The operating principle of a countercurrent freezer, e.g. a belt freezer or a spiral freezer, is the same as that of a blast freezer, except the food being frozen is transported through a countercurrent of cold air or liquid nitrogen. This reduces the evaporation of water from the food.

In fluidised bed freezers, the food is fluidised with air of $-25\text{ }^{\circ}\text{C}$ to $-40\text{ }^{\circ}\text{C}$ by passing the air vertically upwards through a perforated tray or conveyor belt and through a bed of food 2–20 cm thick. The shape and size of the food pieces determine the thickness of the fluidised bed and the air velocity for fluidising. In this system, food comes into more extensive contact with the air than in blast freezers, so that all surfaces are frozen simultaneously and uniformly. This results in faster freezing and less dehydration, which also results in less frequent defrosting. Fluidised bed freezing is restricted to small particulate foods, e.g. peas, sweet maize kernels, shrimps and strawberries.

In cooled surface freezers, vertical or horizontal hollow plates are cooled with a refrigerant of about $-40\text{ }^{\circ}\text{C}$. The food is put on the surface in thin layers. Sometimes the plates are pressed slightly together. This improves the contact between the food and the freezing plates. One advantage of such freezers is that little dehydration of the food takes place, which reduces the frequency of defrosting. A special form is the scraped surface freezer. This consists of a freezing cylinder containing rotating knives which remove the frozen material from the freezing surface. This type of equipment is used in ice-cream production for example.

In immersion freezers, packaged food is passed through a bath of refrigerated glycol, brine, glycerol or calcium chloride solution on a submerged mesh conveyor. High freezing rates are obtained with this method. It is used for example for freezing concentrated orange juice in cans and for pre-freezing film-wrapped poultry prior to blast freezing.

In cryogenic freezing, the food is in direct contact with the refrigerant, which can be solid or liquid carbon dioxide or liquid nitrogen. The refrigerant evaporates or sublimates away, removing the heat from the food and causing rapid freezing. Liquid nitrogen and carbon dioxide refrigerants are colourless, odourless and inert.

Cryo-extraction is a method of subtractive enrichment which consists of removing water from bunches of grapes to increase the sugar content of the must. The objective of cryo-extraction is to eliminate some water present in the raw material by selective freezing. The grapes are placed in a cold room at a temperature midway between the freezing temperature of the richest grapes and that of the least rich grapes. The duration of the treatment of the grape crop is from 12 to 20 hours at temperatures of between -3 and $-6\text{ }^{\circ}\text{C}$. The technique is performed only on grapes harvested manually and carried out in low perforated crates, to achieve a slow and homogeneous lowering of the temperature over all the grapes. The pressing makes it possible to select the ripest juices, i.e. those which flow out first. The maximum pressure used for pressing is 4 bar.

Finally, concentration by cold is a technique applied only for wines. It consists of eliminating a part of the water from a wine to increase its alcohol strength. This technique is regulated. The wine is cooled below the temperature where ice crystals form, but the alcohol does not freeze. The crystals are prevented from congealing together by constant mixing. When a sufficient quantity of water has thus solidified, the liquid is separated from the crystals by centrifuges or pressure-operated extractors.

Energy consumption is the major environmental issue. Electrical energy is needed for the fans for air circulation and the freezing system. For example, deep freezing is the step that consumes the most energy in the manufacture of deep-frozen vegetables, consuming $80\text{--}280\text{ kWh/t}$ of frozen vegetables. Energy amounting to about 0.003 kWh/m^2 (0.01 MJ/m^2) floor surface of tunnel is also consumed in the form of hot water. The energy consumption of a freezing tunnel depends on various factors and the following list uses the deep freezing of fruit and vegetables to illustrate these [15, Van Bael J. 1998]. Energy consumption depends, for example, on the following:

- The type of food to be frozen, e.g. voluminous vegetables, such as cauliflower florets are more difficult to freeze than small vegetables such as peas or diced carrots.
- The temperature of the food at the entrance to the freezing tunnel. The higher this temperature is, the more heat has to be removed from the food before it is frozen.
- The mass flow rate of the food. The higher the flow rate, the higher the quantity of energy that needs to be removed, and the greater the demand for cold air in the tunnel.
- The residence time, which also determines the demand for cold air in the freezing tunnel. The longer the residence time, the more chance the food has to freeze. The thickness of the layer of food is directly proportional to the required residence time.
- The energy consumption which is determined by the airflow rates in the freezing tunnel. The higher the airflow rates, the better the heat exchange between the evaporators and the air on one hand, and the air and the food on the other hand. Higher airflow rates lead to

- higher energy consumption by the fans and higher cooling loads for the freezing tunnel; the full output of the motors needs to be cooled.
- The efficiency or the COP, which plays a role in the energy consumption of freezing tunnels. As explained earlier, the efficiency is mainly determined by the condensation and evaporator temperature.

The energy consumption per unit of weight of frozen product depends very much on the parameters set for the evaporator temperature, fan rating and product flow rate, and the condensation pressures and type of product being processed. Since many factors affect the specific energy consumption, it is therefore only possible to give broad ranges for consumption [15, Van Bael J. 1998].

19.2.7 Utility processes

19.2.7.1 Vacuum generation

Vacuums are used primarily to reduce the temperature at which operations take place, thereby reducing potential deterioration in the quality of the material being processed or, in the case of edible oil processing, to avoid unwanted oxidation of the product during processing at higher temperatures. A vacuum is applied to many unit operations in the FDM sector, e.g. drying, evaporation, neutralisation and filtration.

There are three basic systems for producing a vacuum, i.e. steam jet ejectors, reciprocating pumps and rotary vacuum pumps.

A steam jet ejector, which can produce absolute pressures down to 1 mmHg or 2 mmHg (133 Pa or 267 Pa), consists of a steam nozzle that discharges a high-velocity jet across a suction chamber connected to the equipment. The gas is entrained in the steam and carried into a venturi-shaped diffuser that converts the velocity energy of the steam into pressure energy. The steam and vaporised material from the ejector are condensed either directly in a spray of water, e.g. barometric condensers, or indirectly with surface-type condensers or especially condensed under low temperature conditions, e.g. ice condensation below -20 °C.

With barometric condensers, the cooling water can be used on a once-through basis or recirculated, e.g. in a closed circuit. In edible oil processing, for saponification of FFA, this is done over cooling towers, e.g. under high pH conditions. With indirect condensers, the condensate can be recovered. The size of the condenser depends on the cooling temperature used, and this also determines the amount of steam required. Chilling or freezing systems can be used to enable operation at low temperature, thereby reducing steam usage.

The reciprocating pump, which can produce absolute pressures down to 10 mmHg (1 333 Pa), is of the positive displacement type. Air is drawn into the pump chamber and then compressed by means of a piston before being discharged. Reciprocating vacuum pumps can be either single or multistage devices. The number of stages is determined by the compression ratio. The compression ratio per stage is generally limited to four.

Rotary vacuum pumps, which can produce absolute pressures as low as 0.01 mmHg (1.33 Pa), are again of the positive displacement type, i.e. essentially constant volume with variable discharge pressure. The discharge pressure will vary with the resistance on the discharge side of the system. The widely used water ring vacuum pump has the inlet and outlet ports located on the impeller hub. As the vaned impeller rotates, centrifugal forces drive the sealing liquid against the walls of the elliptical housing, causing the air to be successively drawn into the vane cavities and expelled with the discharge pressure.

Water is used in water-ring-type vacuum pumps for cooling and for sealing. To reduce water consumption, the water is normally recirculated in closed-circuit systems with a bleed-off

determined by the condensable matter. Waste water is produced which contains soluble organic material.

If steam jet ejectors are used for vacuum production, not only the medium coming from the evacuated plant has to be condensed, but also the driving steam of the jet ejector. This is normally done in spray condensers. Here, water is used to condense the steam along with any volatiles carried over. For large installations, the volume of water used to condense the steam can be significant, i.e. during refining of sugar or edible oil. The volatile material carried over is condensed in the water, thereby increasing the level of dissolved organic material. To reduce water consumption, water can be recirculated over cooling towers. In this case, an outlet from the system is required for the condensed steam. This can lead to a concentration of the organic material condensed in the water. With indirect condensers or heat exchangers, the volume of condensate is equivalent to the condensed live steam and other condensable matter, and will contain any organic volatiles carried over. With chilling or freezing systems, the volume of condensate is reduced further.

Non-condensable material may be discharged into the air with steam jet ejectors. Depending on the material being processed, this discharge may result in odour emissions. If condenser water is recirculated over cooling towers, the drift/mist from the towers may result in odour emissions. Indirect recirculation with heat exchangers with two cycles may be used in this case. Heat exchangers have to be cleaned regularly.

GLOSSARY

This glossary is meant to facilitate the understanding of the information contained in this document. The definitions of terms in this glossary are not legal definitions (even if some of them may coincide with definitions given in European legislation), they are meant to help the reader understand some key terms in the context of their use in the specific sector covered by this document.

This glossary is divided up into the following sections:

- I. ISO country codes
- II. Monetary units
- III. Unit prefixes, number separators and notations
- IV. Units and measures
- V. Chemical elements
- VI. Chemical formulae commonly used in this document
- VII. Acronyms
- VIII. Technical definitions

I. ISO country codes

ISO code	Member State
<i>Member States (*)</i>	
AT	Austria
BE	Belgium
CZ	Czechia Republic
DE	Germany
DK	Denmark
ES	Spain
FI	Finland
FR	France
IE	Ireland
IT	Italy
NL	Netherlands
PL	Poland
PT	Portugal
SE	Sweden
UK	United Kingdom
<i>Non-member countries</i>	
US	United States
(*) The protocol order of the Member States is based on the alphabetical order of their geographical names in the original language(s).	

II. Monetary units

Code ⁽¹⁾	Country/territory	Currency
<i>Member State currencies</i>		
EUR	Euro area ⁽²⁾	euro (pl. euros)
GBP	United Kingdom	pound sterling (pl. pounds sterling)
<i>Other currencies</i>		
USD	United States	US dollar
⁽¹⁾ ISO 4217 codes. ⁽²⁾ Includes Austria, Belgium, Cyprus, Estonia, Finland, France, Germany, Greece, Ireland, Italy, Luxembourg, Malta, the Netherlands, Portugal, Slovakia, Slovenia and Spain.		

III. Unit prefixes, number separators and notations

Numbers in this document are written using the '.' character as the decimal separator and the space as the separator for thousands.

The following table contains the frequently used prefixes:

Symbol	Prefix	10^n	Word	Decimal Number
k	kilo	10^3	Thousand	1 000
h	hecto	10^2	Hundred	100
da	deca	10^1	Ten	10
-----	-----	1	One	1
d	deci	10^{-1}	Tenth	0.1
c	centi	10^{-2}	Hundredth	0.01
m	milli	10^{-3}	Thousandth	0.001

IV. Units and measurements

TERM	MEANING
atm	normal atmosphere (1 atm = 101325 N/m ²)
bar	bar (1.013 bar = 1 atm)
billion	thousand million (10 ⁹)
°Bx	Brix degree
°C	degree Celsius
cm	centimetre
d	day
°C/W	thermal resistance
dB	Decibel. The unit of measuring noise emission levels
dB(A)	Noise is measured in decibels (dB). To address the way the human ear responds to sound of different frequencies (pitches), an A-weighting is commonly applied, and the measurements are expressed in dB(A). Every 3 dB(A) reduction is equivalent to halving the noise emission level.
eV	electron volt
g	gram
GJ	gigajoule
Hz	hertz
h	hour
ha	hectare (10 ⁴ m ²) (=2.47105 acres)
hl	hectolitre
hPa	hectopascal (1hPa = 100 Pa)
J	joule
K	kelvin (0 °C = 273.15 K)
kcal	kilocalorie (1 kcal = 4.19 kJ)
kg	kilogramme (1 kg = 1000 g)
kJ	kilojoule (1 kJ = 0.24 kcal)
kPa	kilopascal
kt	kilotonne
kW	kilowatt
kW _e	kilowatt in the form of electrical energy
kWh	kilowatt-hour (1 kWh = 3600 kJ = 3.6 MJ = 0.0036 GJ)
kWh _e	kilowatt-hour in the form of electrical energy
l	litre
m	metre
m ²	square metre
m ³	cubic metre
m ² .°C/W	thermal resistance unit
mg	milligram (1 mg = 10 ⁻³ gram)
MJ	megajoule (1 MJ = 1000 kJ = 10 ⁶ joule)
nm	nanometre (1 nm = 10 ⁻⁹ m)
mm	millimetre (1 mm = 10 ⁻³ m)
m/min	metres per minute
Mt	megatonne (1 Mt = 10 ⁶ tonne)
Mt/yr	megatonnes per year
mV	millivolts
MW _e	megawatts electric (energy)
MW _{th}	megawatts thermal (energy)
ng	nanogram (1 ng = 10 ⁻⁹ gram)
Nm ³	normal cubic metre (101.325 kPa, 273 K)

TERM	MEANING
OU _E	European odour unit
Pa	pascal
ppb	parts per billion
ppm	parts per million (by weight)
ppmv	parts per million (by volume)
s	second
t	metric tonne (1000 kg or 10 ⁶ gram)
t/d	tonnes per day
t/yr	tonne(s) per year
V	volt
vol-%	percentage by volume
W	watt (1 W = 1 J/s)
wt-%	percentage by weight
yr	Year
~	around; more or less
µm	micrometre (1 µm = 10 ⁻⁶ m)

V. Chemical elements

Symbol	Name
Ca	Calcium
Cu	Copper
Fe	Iron
N	Nitrogen
Mg	Magnesium
P	Phosphorus
S	Sulphur
Zn	Zinc

VI. Chemical formulae commonly used in this document

Symbol	Name
CaO	Calcium oxide
Ca(OH) ₂	Calcium hydroxide
CCl ₄	Carbon tetrachloride
CH ₄	Methane
Cl ₂	Chlorine
CO	Carbon monoxide
CO ₂	Carbon dioxide
FeCl ₃	Iron trichloride
HCl	Hydrochloric acid
H ₂ SO ₄	Sulphuric acid
NH ₃	Ammonia
NH ₄	Ammonium
NH ₄ -N	Ammonium nitrogen
SO ₂	Sulphur dioxide
SO ₃	Sulphur trioxide

VII. Acronyms

a _w	Water activity The water activity (a _w) of a given food is defined as: $a_w = p_f/p_w$ where p _f and p _w are the pressures of water vapour in equilibrium with the given food system and with pure water, respectively, both at the same temperature
BAT	Best Available Technique(s), as defined in Article 3(10) of the IED
BAT-AEL	Best Available Techniques - associated emission level, as defined in Article 3(13) of the IED
BAT-AEPL	Best Available Techniques - associated performance emission level, as described in Section 3.3.2 of Commission Implementing Decision 2012/119/EU
BOD	Biochemical oxygen demand
BREF	Best available techniques (BAT) reference document
C ₁ , C ₂ etc.	Organic compounds indicated by the number of carbon atoms
CEN	The European Committee for Standardisation
CEFS	Comité Européen des Fabricants de Sucre
CHP	Cogeneration of heat and power (combined heat and power)
CIAA	Confederation of the food and drink industries of the EU
CIP	Cleaning-in-place
CLM BREF	BAT Reference Document for for the Production of Cement, Lime and Magnesium Oxide
COD	Chemical oxygen demand
COP	Coefficient of performance
CWW BREF	BAT Reference Document in the Common Waste Water and Waste Gas Treatment/Management Systems in the Chemical Sector
DAF	Dissolved air flotation
DC	Dry condensing
DDGS	Distiller's dried grains with solubles
DMRI	Danish Meat Research Institute
DT	Desolventiser-toaster
EDTA	Ethylenediaminetetraacetic acid
EBPR	Enhanced biological phosphorus removal
EC	European Commission
ECF	European Coffee Federation
EFS BREF	BAT Reference Document on Emissions from Storage
EGSB	Expanded granular sludge blanket (reactor)
EIPPCB	European IPPC Bureau
EMAS	Eco-Management and Audit Scheme
EMS	Environmental management system
EN	European Norming (EN standards)
EP	Electrostatic precipitator
ENE BREF	BAT Reference Document for Energy Efficiency
EPA	US Environment Protection Agency
ESP	Electrostatic precipitator
EU	European Union
EUPPA	European Potato Processors' Association
FBD	Fluidised bed dryer
FDM BREF	BAT Reference Document for the Food, Drink and Milk Industries
FFA	Free fatty acids

F/M ratio	Food to microorganism ratio
FOG	Fats, oils and greases
HACCP	Hazard Analysis and Critical Control Points
HCFC	Hydrochlorofluorocarbon
HDPE	High-density polyethylene
HEPA	High-efficiency particulate air
HFC	Hydrofluorocarbon
HHST	High-heat short-time (pasteurisation)
HTD	High-temperature drying
HTST	High-temperature short-time (pasteurisation)
IC	Internal circulation (waste water treatment reactor)
ICS	BAT Reference Document for Industrial Cooling Systems
ICW	Integrated constructed wetlands
ISO	International Organisation for Standardisation
IPPC	Integrated pollution prevention and control
LCP BREF	BAT Reference Document for Large Combustion Plants
LPG	Liquified petroleum gas
LTD	Low-temperature drying
MBR	Membrane bioreactor
MF	Microfiltration
MLSS	Mixed liquor suspended solids
MS	Member State(s) of the European Union
MVR	Mechanical vapour recompression
MWWTP	Municipal waste water treatment plant
NF	Nanofiltration
NGO	Non-governmental organisation
P	Phosphorus
PAH	Polyaromatic hydrocarbon
PE	Polyethylene
PET	Polyethylene terephthalate
PM	Particulate matter
PP	Polypropylene
PS	Polystyrene
PTFE	Polytetrafluorethylene
PVC	Polyvinyl chloride
PVPP	Polyvinylpyrrolidone
RBC	Rotating biological contactors
RO	Reverse osmosis
RPM	Rotations per minute
SA BREF	BAT Reference Document for Slaughterhouses and Animal By-Products Industries
SBR	Sequencing batch reactor
SME	Small and medium enterprise(s)
SO _x	Sulphur oxides
TN	Total nitrogen
TOC	Total organic carbon
TP	Total phosphorus
TSS	Total suspended solids
TVOC	Total volatile organic carbon, expressed as C (in air)
TVR	Thermal vapour recompression
TWG	Technical working group
UASB	Upflow anaerobic sludge blanket (reactor)
UF	Ultrafiltration

UHP	Ultra-high pressure
UHT	Ultra-high temperature (sterilisation)
UV	Ultraviolet
VOC	Volatile organic compound
VDI	Verein Deutscher Ingenieure (The Association of German Engineers)
WFE	Wiped film evaporator
WT BREF	BAT Reference Document for Waste Treatment
WWTP	Waste water treatment plant

VIII. Technical definitions

Activated sludge process	A biological waste water treatment by which bacteria that feed on organic wastes are continuously circulated and put in contact with organic waste in the presence of oxygen to increase the rate of decomposition.
Aeration	A biological process by which air is introduced to increase the oxygen concentration in liquids. Aeration may be performed by bubbling air through the liquid, spraying the liquid into the air or agitating the liquid to increase surface absorption. Blowing fresh and dry air through stored crops such as cereal grains, in order to decrease their temperature and/or humidity.
Anaerobic	A biological process which occurs in the absence of oxygen.
Aseptic	Sterile or free of bacterial contamination.
Baffle	Plate which hinders or regulates the flow of fluid.
Biochemicals	Chemicals that are either naturally occurring or identical to naturally occurring substances. Examples include hormones, pheromones and enzymes. Biochemicals function as pesticides through non-toxic, non-lethal modes of action, such as disrupting the mating pattern of insects, regulating growth or acting as repellents.
Biodegradable	That can be broken down physically and/or chemically by microorganisms. For example, many chemicals, food scraps, cotton, wool and paper are biodegradable.
Biodiversity	The number and variety of different organisms in the ecological complexes in which they naturally occur. Organisms are organised at many levels, ranging from complete ecosystems to the biochemical structures that are the molecular basis of heredity. Thus, the term encompasses different ecosystems, species and genes that are present in a healthy environment. A large number of species characterises the food chain, representing multiple predator-prey relationships.
Biomass	Organic matter available on a renewable basis. Biomass includes forest, agricultural crops and wastes, wood and wood wastes, animal wastes, livestock operation residues, aquatic plants, fast-growing trees and plants, and municipal and industrial wastes.
Brix degree (°Bx)	Also called % DSSC (% dry soluble substances content). Concentration, expressed as sucrose content, of all substances dissolved in a liquid. X °Bx is equivalent to the concentration of all substances dissolved in a juice which causes a refractometric deviation equal to that caused by a solution of X grams of sucrose per 100 grams of solution.
Cake	Carbonation slurry after concentration with filter presses to about 70 % DS, e.g. with precipitated calcium carbonate.
Catchpot	Fine mesh basket placed over floor drains, to prevent solids from entering the drainage system and the WWTP.
Caustic	Sodium hydroxide.
CIP system	Acronym for cleaning-in-place. It is a practice for cleaning tanks, pipelines, processing equipment and process lines by circulating water and cleaning solutions through them without dismantling the pipelines or equipment.
Confectionery	Sweets and sweet preparations such as cakes.
Cosettes	Thin slices of sugar beet.
Crustacean	Member of the <i>Crustacea</i> , a large class of arthropod (animal of the phylum <i>Arthropoda</i> , with segmented body and jointed limbs) with hard shells, mainly aquatic, e.g. crab, lobster, shrimp.
Decoction	Concentration of or extraction of the essence of a substance by boiling.
Defrost	The removal of frost from the inside of a refrigerator or cold store.

Degumming	The removal of gums in vegetable oil to avoid colour and taste reversion during subsequent refining steps.
Eutrophication	The pollution of a body of water by sewage, fertilisers washed from the land, and industrial wastes (inorganic nitrates and phosphates). These compounds stimulate the growth of algae, reducing the oxygen content in the water, and so killing animals with a high oxygen requirement.
Evisceration	Step in the slaughter process by which the contents of the chest and belly cavities of the animals are removed.
Fouling	The process of becoming dusty or clogged, e.g. in which undesirable foreign matter accumulates in a bed of filter or ion exchanger media, clogging pores and coating surfaces, thus inhibiting or delaying proper bed operation. The fouling of a heat exchanger consists of the accumulation of dirt or other materials on the wall of a heat exchanger, causing corrosion, roughness and ultimately leading to a lowered rate of efficiency.
Fresh-pack	Fruit or vegetables which have been packed fresh.
Germination	The process whereby seeds or spores sprout and begin to grow. Also called sprouting.
Herbicide	Any chemical toxic substance, usually used to kill specific unwanted plants, especially weeds.
Hull	Outer covering of fruit and seeds, especially pod of peas and beans, husk of grain, or green calyx of strawberry.
Ice-water	Cooled water which is then used for cooling.
Immission	Pollutant mass/concentration that is dissipated to the environment. It is measured where the environmental impact occurs.
Kieselguhr	A light soil consisting of siliceous remains of microscopic one-celled or colonial algae, used for filtering purposes, also called diatomaceous earth.
Lecithin	Any of a group of natural phospholipids which are esters of a phosphatidic acid with choline; such phospholipids collectively; a mixture containing these, used commercially as a food emulsifier etc.
Lees	The sediment of wine or some other liquids.
Lyophilisation (freeze-drying)	The process of preserving food products by freezing them and then evaporating the water (in the form of ice) by sublimation.
Malt sprouts	The shoots which grow during germination of malt.
Marc	The residue, e.g. skins, pits and seeds, remaining after the juice has been pressed from a fruit, usually apple or grapes.
Mash	Malt mixed with hot water to form wort.
Miscella	Mixture of crude vegetable oil and hexane formed during solvent extraction of vegetable oils.
Mitzithra cheese	Cheese made from whey.
Mollusc	Soft-bodied and usually hard-shelled animal belonging to the phylum <i>Mollusca</i> .
Must	Any juice or liquid prepared undergoing alcoholic fermentation, e.g. grape juice or the pulp of apples or pears.
Native starch	Refined starch without any chemical and/or physical modification.
Pasteurisation	Thermal process, treatment, or combination thereof, that is applied to food to reduce the most resistant microorganisms of public health significance to a level that is not likely to present a public health risk under normal conditions of distribution and storage. Thermal pasteurisation treatments are time/temperature equivalent combinations to obtain a certain decimal (log) reduction of viable organisms with a reduced detrimental effect on flavour and chemistry of the food.

Pesticide	Biological, physical or chemical agent used to kill pests. In practice, the term pesticide is often applied only to chemical agents. Various pesticides are known as insecticides, nematocides, fungicides, herbicides and rodenticides, i.e., agents primarily effective against insects, nematodes (or roundworms), fungi, weeds and rodents, respectively.
Pomace	The residue, e.g. skins, pits and seeds, remaining after the juice has been pressed from apples, pears and olives for example.
Pome	A fleshy fruit with a central seed-bearing core, e.g. apple.
Potato juice	Juice extracted from potato pressing.
Potato water	Waste water generating from the potato processing.
Primary packaging	Packaging conceived so as to constitute a sales unit to the final user or consumer at the point of purchase.
Residue	Substance or object generated by the activities covered by the scope of this document, as waste or by-product.
Re values (Reynolds number)	The Reynolds number is the ratio of inertial forces, as described by Newton's second law of motion, to viscous forces. If the Reynolds number is high, inertial forces dominate, resulting in a turbulent flow. If it is low, viscous forces prevail, resulting in a laminar flow.
Rootlet	A small root, e.g. on grain during malting.
Secondary packaging	Packaging conceived so as to constitute at the point of purchase a grouping of a certain number of sales units whether the latter is sold as such to the final user or consumer or whether it serves only as a means to replenish the shelves at the point of sale; it can be removed from the product without affecting its characteristics.
Sparge	To sprinkle, e.g. water, aerate a liquid with air or inject steam. In brewing, a spray of hot water sprinkled over the malt.
Standardised milk	Milk which has been treated to adjust the fat content to a specified percentage which depends on the milk's intended use.
Soil tare	The weight of soil, gravel and stones carried with crops when they are harvested.
Sump	A pit, well or hole used for collecting water or other fluid.
Tempering	A process used in chocolate processing that ensures product quality and appearance; enables handling of liquid chocolate for various applications; ensures viscosity control; and enables net weight requirements to be met. Tempering is also the controlled thawing of meats.
Tertiary packaging	Packaging conceived so as to facilitate handling and transport of a number of sales units or grouped packagings in order to prevent damage due to physical handling and transport.
Thaw	To unfreeze food or raw materials.
Thermal resistance (K/W or °C/W)	The thermal resistance of an insulating material, in thermal ohms, is the R-value (a commercial unit used to measure the effectiveness of thermal insulation) divided by the thickness of the material, in metres.
Trub	A coarse coagulum of proteinaceous precipitated material which is separated from the wort as part of the brewing process.
Van der Waals forces	Forces that exist between molecules of the same substance. These forces are much weaker than chemical bonds, and random thermal motion around room temperature can usually overcome or disrupt them. The forces operate only when molecules pass very close to each other, during collisions or near misses.

Vinasse	A by-product that is generated when processing molasses. After the fermentable sugar in molasses has been used by the microorganisms (e.g. yeasts) and the compounds produced have been separated out (e.g. alcohol is distilled), this is the remaining nutrient medium. The non-sugar substances that have not been assimilated and metabolic side products are in this liquid. Vinasse may be concentrated to give a solids content of 70 % by multiple-effect evaporators.
Viscera	The organs contained within the trunk, considered collectively, e.g. the digestive tract, heart and lungs.
Wort	A sweet infusion of ground malt or other grain before fermentation, used to produce beer and distilled malt liquors for example.

REFERENCES

- [1] CIAA, *CIAA Background Document for the Technical Working Group on the FDM BREF Rev. 7*, 2002.
- [2] IED Forum, Comments from IED Forum members on the final draft of the revised FDM BREF (November 2018) , 2018.
- [3] The Brewers of Europe, 'Comments on pre-final draft of the revised FDM BREF', Personal Communication, 2018.
- [4] CEFS, CEFS proposal for description of beet pulp drying (comments on pre-final draft) , 2018.
- [5] German Dairy Association, *Translation of extracts and additions made 2001. VDM.*, 1999.
- [6] Environment Agency of England and Wales, *Process Descriptions for the Food and Drink sector*, 2000.
- [7] Environment Agency of England and Wales, *BAT and Waste Minimisation in Food and Drink Sector*, 2000.
- [8] Environment Agency of England and Wales, *IPPC Best Available Techniques (BAT) for Effluent Management in the Food & Drink Sector*, 2000.
- [9] Envirowise (UK), Reducing the Cost of Cleaning in the Food and Drink Industry Guide - GG 154, Environmental Technology Best Practice Programme, <http://www.etsu.com/etbpp> , 1998.
- [10] Envirowise (UK) & Entec UK Ltd, Low-Cost Process Control in Food and Drink Processing - Guide GG 220, Environmental Technology Best Practice Programme, <http://www.etsu.com/etbpp> , 1999.
- [11] Envirowise (UK), Reducing the Water and Effluent Costs in Breweries - Guide GG 135, Environmental Technology Best Practice Programme, <http://www.etsu.com/etbpp> , 1998.
- [12] ATV, *ATV Handbuch Industrieabwasser, Lebensmittelindustrie, 4. Auflage, Ernst Sohn Verlag, ISBN 3-433-01467-1*, 2000.
- [13] Nordic Council of Ministers, *BAT Best available technology in the fishing industry, TemaNord*, 1997.
- [14] Belgium-VITO, *Best Available Techniques (BAT) for the fruit and vegetable processing industry*, 2001.
- [15] Van Bael J., *Memorandum on Energy Consumption in the Flemish Frozen Vegetable Sector, VITO*, 1998.
- [16] Willey et al., 'Management of Odorous Emissions in the Food Industry', , 2001.
- [17] TWG, Comments on the pre-final draft of the revised FDM BREF , 2018.
- [18] Environment Agency of England and Wales, *BAT for Cleaning. Extract from UK Interim National BAT Guidance for the Food and Drink Sector*, 2000.
- [19] German Dairy Association, 'Comments on the first draft and associated additional information and personal communications', Personal Communication, 2001.
- [20] Nordic Council of Ministers, *Best Available Techniques (BAT) in Nordic Slaughterhouses, TemaNord*, 2001.
- [21] Nordic Council of Ministers, *BAT for Nordic dairy industry, TemaNord 2001:586*, 2001.
- [22] Carbon Trust, *Food and drink processing. Introducing energy saving opportunities for business*, 2012.
- [23] Envirowise (UK) and Ashact , Reducing Water and Waste Costs in Fruit and Vegetable Processing - Guide GG 280, Environmental Technology Best Practice Programme, <http://www.etsu.com/etbpp> , 2001.
- [24] Fraunhofer CBP, EthaNa – Piloting the Ethanolic Native Extraction of Peeled Rapeseed - <https://www.cbp.fraunhofer.de/en/research/reference-projects/EthaNa.html> , 2019.

References

- [25] COM, *Preparatory study for a review of Regulation (EC) No 842/2006 on certain fluorinated GHG*, 2011.
- [26] Envirowise (UK), *Turning Waste into Profit - Case Study GC 150*, Environmental Technology Best Practice Programme, <http://www.etsu.com/etbpp> , 2000.
- [27] Envirowise (UK), *Pigging Cuts Costs, Recovers Product and Reduces Effluent - Case Study GC 261*, Environmental Technology Best Practice Programme, <http://www.etsu.com/etbpp> , 2000.
- [28] Envirowise (UK), *Cutting Water and Effluent Costs in Fish Processing - Case Study GC 202*, Environmental Technology Best Practice Programme, <http://www.etsu.com/etbpp> , 1999.
- [29] Danbrew Ltd, *Environmental Management in the Brewing Industry*, UNEP *Industry and Environment*, 92-807-1523-2, 1996.
- [30] TWG, 'Compiled and sorted list of TWG comments on revised draft BAT conclusions', Personal Communication, 2018.
- [31] CEFS, *Guide to establishing BAT in the sugar industry*, 2001.
- [32] CleanSmoke, *Best available techniques for the smoking of food*, 2018.
- [33] Borja et al., 'Treatment technologies of liquid and solid wastes from two-phase olive oil mills', *Grasas y Aceites*, Vol. 57, 2006, pp. 32-46' , 2006.
- [34] Italy, *Italy comments to the FDM data workshop* , 2017.
- [35] Germany, *Best Available Techniques Reference Document on the Food and Milk Industry*, BMU, Hannover University, *fdm/tm/65*, 2002.
- [36] EC, 'Council Directive 98/83/EC of 3 November 1998 on the quality of water intended for human consumption', *Official Journal of the European Communities*, Vol. L 330, 5.12.1998, 1998, pp. 32-54.
- [37] The Brewers of Europe, *The Brewers of Europe comments to the FDM data workshop* , 2017.
- [38] CEOC, *Requirements for boiler water and boiler feed water - R 54/CEOC/CP 84 Def*, 1984.
- [39] Environment Agency of England and Wales, *Integrated pollution prevention and control Energy efficiency - IPPC H2, Horizontal Guidance Note*, 2001.
- [40] UNEP et al., *Cleaner Production Assessment in Dairy Processing*", 92-807-1842-8, 2000.
- [41] Rocha dos Santos Mathias et al., 'Journal of Brewing and Distilling: Solid wastes in brewing process: A review' , , 2014.
- [42] Greek Ministry for the Environment, *Food industry IPPC study*, 1997.
- [43] Italian contribution, 'BAT candidates for dairy industry', Personal Communication, 2002.
- [44] Italian contribution, 'Dairy industry - General information', Personal Communication, 2001.
- [45] FoodDrinkEurope, 'FDE Document Rev7 Chapter 2 BREF 2006', Personal Communication, 2002.
- [46] FEFAC, *Feed for fur animals general information* , 2017.
- [47] Denmark, *Denmark comments to the FDM data workshop* , 2017.
- [48] European Starch Association, *Comment on the UK Document Process descriptions - fm No.10* , 2001.
- [49] Environment Agency of England and Wales, 'BAT note on frying', Personal Communication, 2000.
- [50] Junta de Andalucia and Agencia de Medio Ambiente, *Sistemas de obtencion de aceite de oliva sin produccion de alpechin. Situacion actual*, 1994.
- [51] Ullmann , *Encyclopedia of Industrial Chemistry*, Wiley-VCH Verlag GmbH, 2001.
- [52] Italy, 'Consumption & emission data for meat and fruit and vegetables sectors', Personal Communication, 2001.

- [53] COM, Directive of the European Parliament and of the Council on the promotion of cogeneration based on a useful heat demand in the internal energy market, COM(2002) 415 final , 2002.
- [54] EUPPA, EUPPA suggestions for modifications , 2018.
- [55] COM, *Mission report-Site visits to BE, NL*, 2017.
- [56] ANMF, 'Proposal to complete the grain milling chapter', Personal Communication, 2017.
- [57] Environment Agency of England and Wales, UK comments to the first draft , 2002.
- [58] FoodDrinkEurope, 'FDE Document Rev7 Chapters 4 and 5 BREF 2006', Personal Communication, 2002.
- [59] EU, Directive 2008/98/EC of the European Parliament and of the Council of 19 November 2008 on waste and repealing certain Directives , 2008.
- [60] Germany, 'Germany comments to the FDM data workshop', Personal Communication, 2017.
- [61] UK, Comments to the first draft , 2002.
- [62] CIAA-FEDIOL, Comments to the first draft - vegetable oil , 2002.
- [63] CIAA-AAC-UFE, Comments to the first draft - starch , 2002.
- [64] CIAA-UNAFPA, Comments to the first draft - pasta , 2002.
- [65] CIAA-EDA, Comments to the first draft - dairy , 2002.
- [66] Italy, Comments to the first draft - fruit and vegetable , 2002.
- [67] Boehm et al., *Comprehensive preliminary studies and proposals for measures of risk reduction strategies for EDTA*, Fraunhofer Institute, 2002.
- [68] Knepper et al. , *Eintrage synthetischer Komplexbildner in die Gewasser*, ESWE Institut for Wasserforschung, FKZ 299 24 284, 2001.
- [69] Layman, *Environmentally friendly smoking*, 2015.
- [70] CADDET, Quadruple-effect milk evaporator uses mechanical vapour recompression, IEA, OECD, <http://www.caddet-ee.org> , 1992.
- [71] AWARENET, *Tools for prevention and minimisation of agro-food wastes generation in European industry*, GRD1-CT-2000-28033, 2002.
- [72] Brewers Europe, *Guidance Note for establishing BAT in the brewing industry*, 2002.
- [73] Nielsen et al., *BAT in the Danish sugar industry*, 2002.
- [74] World Bank (IBRD) et al., 'Pollution prevention and abatement handbook - Toward cleaner production' , 1998.
- [75] FEDIOL, 'Candidate BATs', Personal Communication, 2002.
- [76] CleanSmoke , The case of purified smoke as BAT , 2017.
- [77] CADDET, Air treatment in a cheese warehouse, [twgfood\caddet_cheese_air.html](http://twgfood/caddet_cheese_air.html) , 1997.
- [78] Metcalf & Eddy, *Wastewater engineering - Treatment, disposal and reuse, 3rd Edition*, McGraw-Hill, Inc., 0-07-100824-1, 1991.
- [79] Leendertse A., *Fact-sheet on non-thermal plasma treatment of odour*, 2003.
- [80] Germany, *VDI 3892:2015 Emission control - Roasted-coffee producing industry*, 2015.
- [81] Sole, 'UHT milk processing - a BAT candidate technology', Personal Communication, 2003.
- [82] Unione Industriali Pastai Italiani, *The efficient use of energy in the Italian pasta industry*, 2002.
- [83] Austrian contribution, 'Production of citric acid', Personal Communication, 2002.
- [84] Austria, Comments to the 1st draft , 2002.
- [85] Clitravi, 'Clitravi comments to the FDM data workshop', Personal Communication, 2017.
- [86] UBC Civil Engineering, Membrane BioReactor, <http://www.civil.ubc.ca/home/civ1525/students00/rachelui/geninfo.html> , 2003.
- [87] Belgium-VITO, *The BAT study for potatoes, vegetables and fruit processing industry*, 2015.

References

- [88] CIAA-CEFS, Comments on the second draft , 2003.
- [89] EDA, 'Consumption and emission data', Personal Communication, 2002.
- [90] Verband Deutscher Oelmuehlen, 'Contribution to Section 3.3.9.4', Personal Communication, 2003.
- [91] Giner Santonja et al., *Best Available Techniques (BAT) Reference Document for the Intensive Rearing of Poultry or Pigs (IRPP BREF)*, European Commission, JRC Seville EIPPCB, 2017.
- [92] Gergely E., 'Production of DDGS (Distiller's Dried Grains with Solubles)', Personal Communication, 2003.
- [93] COM, *Best Available Techniques (BAT) Reference Document in the Slaughterhouses and Animal By-products Industries (SA BREF)*, 2005.
- [94] Germany, Comments on the second draft , 2003.
- [95] CIAA-UNAFPA, Comments on the second draft , 2003.
- [96] Italy, Comments on the second draft , 2003.
- [97] CIAA-FEDIOL, Comments on the second draft , 2004.
- [98] TWG, 'Comments on Draft 1 of the revised FDM BREF', Personal Communication, 2017.
- [99] EC, 'Regulation (EC) No 1774/2002 of the European Parliament and of the Council of 3 October 2002 laying down health rules concerning animal by-products not intended for human consumption', *Official Journal of the European Communities*, Vol. L 273, 10.10.2002, 2002, pp. 1-95.
- [100] Bockisch M., *Nahrungsfette und - öle*, 1993.
- [101] Health and Safety Executive, *Information about Legionnaires' Disease*, 2004.
- [102] Heidemann et al., 'Abwasserteilstrome und reststoffe in der brauerei', , 1993.
- [103] Leendertse A. and Haaland A.T., 'The performance of the APP odour abatement equipment in relation to operating conditions and measurement', , 2003.
- [104] EEC, 'Council Directive 91/676/EEC of 12 December 1991 concerning the protection of waters against pollution caused by nitrates from agricultural sources', *Official Journal of the European Communities*, Vol. L 375, 31.12.1991, 1991, pp. 1-8.
- [105] RC/SPC, *Pollution prevention in olive oil production*, 2000.
- [106] COM, SET-Plan ACTION n°6 - Continue efforts to make EU industry less energy intensive and more competitive , 2016.
- [107] COM, *Best Environmental Management Practice for the Food and Beverage Manufacturing Sector*, 2017.
- [108] NEWPOTATOPRO LIFE project, *Novel energy efficient process for potato protein extraction*, 2007.
- [109] Finland, Comments on the second draft , 2003.
- [110] CIAA, Comments on the second draft , 2003.
- [111] COM, Council Regulation (EEC) No 793/93 of 23 March 1993 on the evaluation and control of the risks of existing substances , 1993.
- [112] Ireland, *Integrated constructed wetlands*, 2003.
- [113] AINIA, *ECODHYBAT project: Eco-Hygienic design of food processing equipment*, 2016.
- [114] COM, 'Council Directive 76/464/EEC of 4 May 1976 on pollution caused by certain dangerous substances discharged into the aquatic environment of the Community', *Official Journal of the European Communities*, Vol. L 129, 18.5.1976, 1976, pp. 23-29.
- [115] European Coffee Federation, Coffee roasting and NOx , 2016.
- [116] CIAA-AAC-UFE, Comments on the second draft , 2003.
- [117] European Coffee Federation, Thumbnail description , 2016.
- [118] COM, Regulation (EC) No 1005/2009 of the European Parliament and of the Council of 16 September 2009 on substances that deplete the ozone layer , 2009.
- [119] Clitravi-Avec, Inputs for the Review of FDM BREF 2006 , 2015.

- [120] EC, 'European Parliament and Council Directive 94/62/EC of 20 December 1994 on packaging and packaging waste', *Official Journal of the European Communities*, Vol. L 365, 31.12.1994, 1994, pp. 10-23.
- [121] COM, 'Regulation No 136/66/EEC of the Council of 22 September 1966 on the establishment of a common organisation of the market in oils and fats', *Official Journal of the European Communities*, Vol. 3025, No 66, 30.9.1966, 1966, pp. 221-231.
- [122] Brewers Europe, Potential BATs , 2004.
- [123] FEFAC, *Candidate BATs for the Animal Feed Sector*, 2015.
- [124] EPA, *Emerging Technologies for Wastewater Treatment and In-Plant Wet Weather Management*, 2013.
- [125] EU, Directive 2010/75/EU of the European Parliament and of the Council of 24 November 2010 on industrial emissions (integrated pollution prevention and control) , 2010.
- [126] Austria, *Status FDM industry in Austria*, 2015.
- [127] COM, EU Platform on Food Losses and Food Waste http://ec.europa.eu/food/safety/food_waste/eu_actions/eu-platform/index_en.htm , 2016.
- [128] CIAA-Federalimentare, Comments on the second draft , 2003.
- [129] Italy M. Frey, Comments on the second draft , 2003.
- [130] Portugal-FIPA, Comments on the second draft , 2003.
- [131] Hall et al., 'Energy from waste and the food processing industry', , 2012.
- [132] COM, *Best Available Techniques (BAT) Reference Document for Energy Efficiency (ENE BREF)*, European Commission, JRC IPTS EIPPCB, 2009.
- [133] Ockerman et al., 'Animal by-product processing and utilisation', , 2000.
- [134] German Dairy Association, *EDTA in detergents*, 1997.
- [135] EDA, *EDA proposal on waste*, 2016.
- [136] Deutsches Institut für Normung p.v., DIN 30600/28004 , 2005.
- [137] EC, Regulation (EU) No 517/2014 of the European Parliament and of the Council of 16 April 2014 on fluorinated greenhouse gases and repealing Regulation (EC) No 842/2006 , 2014.
- [138] Fellows P.J., *Food processing principles and practice*, 2000.
- [139] Health and Safety Executive, *Ventilation of kitchens in catering establishments, Catering sheet No 10*, 2000.
- [140] EC, Regulation EC/1005/2009 of the European Parliament and of the Council of 16 September 2009 on substances that deplete the ozone layer , 2009.
- [141] NuReSys, <http://www.phosphorusplatform.eu/images/Conference/ESPC2-materials/Dewaele%20-%20NuReSys%20From%20P%20recovery%20to%20fertilizer%20production.pdf> , 2016.
- [142] Ellis L. , *Report on SERET cross-flow filtration of wines*, 2002.
- [143] Caddet , *The use of Pinch technology in a food processing factory*, 1999.
- [144] CIAA-EDA, Comments on the second draft , 2003.
- [145] COM, *Best Available Techniques (BAT) Reference Document for Large Combustion Plants (LCP BREF)*, European Commission - JRC IPTS EIPPCB, 2017.
- [146] Desmidt et al., 'Global Phosphorus Scarcity and Full-Scale P-Recovery Techniques: A Review', , 2015.
- [147] Lewis D. N., *Noise abatement measures in the food industry*, 2003.
- [148] Colsen b.v., *Phosphorus removal in anaerobic effluent by struvite process: ANPHOS Life project*, 2013.
- [149] Health and Safety Executive, *Top 10 noise control techniques*, 2000.
- [150] Barale M., *Reducing milk stone formation*, 2004.
- [151] Clitravi-Avec, Bulk information AVEC CLITRAVI , 2016.

References

- [152] AINIA, *Producción de biogás mediante co-digestión anaerobia de residuos/subproductos orgánicos agroindustriales*, 2016.
- [153] UK TWG, *Space requirements for membrane bioreactors*, 2004.
- [154] COM, *First Draft of Best Available Techniques (BAT) Reference Document for Waste Treatment*, 2015.
- [155] COM, *08 Towards a better exploitation of the technical potential of WtE - Draft Final Report 20 June 2016*, 2016.
- [156] Belgium-VITO, *Online monitoring of phosphorus*, 2015.
- [157] Copa-Cogeca, *Best Available Techniques in the sector for industrial production of green fodder*, 2016.
- [158] Germany, *German contribution to the final plenary TWG meeting*, 2005.
- [160] Federación Conservas, *Chemical peach peeling*, 2005.
- [161] Nordic Council of Ministers, *BAT for odour reduction from food industry in Nordic countries*, 2016.
- [162] COM, *Reference Document on the application of Best Available Techniques to Industrial Cooling Systems, 2001*.
- [163] Belgium-VITO, *Best practice for anaerobic treatment of waste*, 2015.
- [164] Directive 2000/60/EC, 'Directive 2000/60/EC of the European Parliament and of the Council of 23 October 2000 establishing a framework for Community action in the field of water policy', *Official Journal of the European Communities*, Vol. L 327, 22.12.2000, 2000, pp. 1-72.
- [165] EEC, 'COUNCIL DIRECTIVE 91/271/EEC of 21 May 1991 concerning urban waste water treatment', *Official Journal of the European Communities*, Vol. L 135, 30.5.1991, 1991, p. 40.
- [166] COM, *Mission report of FDM site visits in Finland*, 2015.
- [167] COM, *Best Available Techniques (BAT) Reference Document on Emissions from Storage (EFS BREF)*, European Commission, JRC IPTS EIPPCB, 2006.
- [168] COM, *Best Available Techniques (BAT) Reference Document for Common Waste Water and Waste Gas Treatment/Management Systems in the Chemical Sector (CWW BREF)*, European Commission, JRC IPTS EIPPCB, 2016.
- [169] Nordic Council of Ministers, *Nordic BAT report on Breweries 2011*, ISBN 978-92-893-2245-4, 60 pages., 2011.
- [170] COM, *Mission report in Spain*, 2015.
- [171] IAF, *International Accreditation Forum website*, 2010.
- [172] EU, 'Regulation (EC) No 1221/2009 of the European Parliament and of the Council of 25 November 2009 on the voluntary participation by organisations in a Community eco-management and audit scheme (EMAS), repealing Regulation (EC) No 761/2001 and Commission Decisions 2001/681/EC and 2006/193/EC', *Official Journal of the European Union*, Vol. L 342, 22.12.2009, 2009, pp. 1-45.
- [173] COM, *DG Environment: What is Emass?*, 2010.
- [174] Eurostat, *Meat production statistics* http://ec.europa.eu/eurostat/statistics-explained/index.php/Meat_production_statistics, 2016.
- [175] ePURE, *Adaption of text in the existing BAT document for Ethanol production*, 2015.
- [176] Eurostat, *Statistics Database*, 2016.
- [177] COM, *Assessment and Summary of the Member States' Implementation Reports for the IED, IPPC Directive, SED and WID*, 2016.
- [178] Every Crumb Counts, *Every Crumb Counts Joint Declaration*, www.everycrumbcounts.eu, 2015.
- [179] COM, *EMAS reports & statistics* (<http://ec.europa.eu/environment/emas/register/reports/reports.do>), 2015.
- [180] COM, *'Closing the loop - An EU action plan for the Circular Economy'*, 2015.

- [181] Tetra Pak, Continuous freezing of ice cream mix , 2015.
- [182] Tetra Pak, Energy-efficient homogenisation device , 2015.
- [183] Tetra Pak, Hibernation for pasteurisers and sterilisers , 2015.
- [184] EDA, *EDA proposal on re-use of water*, 2016.
- [185] Tetra Pak, UHT process without intermediate pasteurisation , 2015.
- [186] Tetra Pak, Beverage processing with in-line blending and recovery functions , 2015.
- [187] Tetra Pak, Optimised juice pasteurization , 2015.
- [188] Tetra Pak, *White paper on Optimized Pasteurization*, 2015.
- [189] Tetra Pak, Radial jet mixing with coaxial injector technology , 2015.
- [190] Tetra Pak, Single-line processing of beverages with particles , 2015.
- [191] Tetra Pak, Sugar dissolving with hydraulic transportation , 2015.
- [192] COM, *Best Available Techniques (BAT) Reference Document for the Food, Drink and Milk Industries (FDM BREF)*, European Commission, JRC IPTS EIPPCB, 2006.
- [193] TWG, Emission and consumption data from data collection , 2015.
- [194] CEFS, *CEFS Sugar Statistics 2015*, 2016.
- [195] CEEV, *Wine thumbnail description*, 2015.
- [196] spiritsEUROPE, *Distilled beverages thumbnail description*, 2015.
- [197] EUROMALT, *Malting thumbnail description*, 2015.
- [198] FoodDrinkEurope, Information for the Ethanol Production Sector , 2015.
- [199] CEFS, From beet field to sugar factory , 2010.
- [200] Italy, *Coffee manufacturing thumbnail description*, 2016.
- [201] FEFAC, *General information for the animal feed sector*, 2015.
- [202] FEFAC, *General information on manufacturing of compound feed and premixtures for food producing animals*, 2015.
- [203] FEDIAF, *Information on pet food manufacturing*, 2015.
- [204] FEFAC, *Applied processes and techniques in manufacturing of compound feed and premixtures for food producing animals*, 2015.
- [205] Nordic Council of Ministers, *BAT in fish processing industry, Nordic perspective*, 2015.
- [206] EDA, *Annual Report, 2014*, 2015.
- [207] Eurostat, Milk and milk product statistics, http://ec.europa.eu/eurostat/statistics-explained/index.php/Milk_and_milk_product_statistics , 2015.
- [208] The Brewers of Europe, *Beer statistics, 2017 Edition*, 2017.
- [209] The Brewers of Europe, *Brewing Descriptor*, 2015.
- [210] EDA, *Bulk information on cleaning*, 2016.
- [211] Rezaei et al., 'Alcohol-free Beer: Methods of Production, Sensorial Defects, and Healthful Effects', , 2010.
- [212] The Brewers of Europe, *Odour with potential nuisance to the community*, 2015.
- [213] FEDIOL, *General information about oilseed processing and vegetable oil refining*, 2015.
- [214] FEDIOL, *Applied processes and techniques: oilseed processing*, 2015.
- [215] FEDIOL, *Applied processes and techniques: vegetable oil refining*, 2015.
- [216] Starch Europe, The EU starch industry, key figures-2014, www.starch.eu/european-starch-industry/ , 2015.
- [217] Starch Europe, The production process, <http://www.starch.eu/extraction-and-processing/> , 2014.
- [218] Eurostat, Agricultural production - crops, http://ec.europa.eu/eurostat/statistics-explained/index.php/Agricultural_production_-_crops , 2015.
- [219] COM, *EU Agricultural Outlook, Prospects for EU agricultural markets and income 2015-2025*, 2015.

References

- [220] Clitravi-Avec, Meat industry – products, processes and environmental effects , 2016.
- [221] European Flour Millers, Facts & Figures, <http://www.flourmillers.eu/page/facts-figures-flour-milling-industry/> , 2016.
- [222] France, French contribution on waste water landspreading in the FDM sector , 2015.
- [223] FEDIOL, *Side document on hexane management during oilseed processing to support a sector specific data gathering*, 2014.
- [224] Denmark, Biofilter for odour reduction , 2015.
- [225] FEFAC, *Key Environmental Impacts of the Manufacturing of compound feed*, 2015.
- [226] EDA, EDA proposals for BAT candidates , 2016.
- [227] United Kingdom, Use of heat pumps within the dairy sector , 2015.
- [228] Belgium-VITO, BAT candidate for phosphorous removal , 2015.
- [229] Belgium-VITO, BAT candidate - Biofilters for treatment of air emissions , 2015.
- [230] Germany, *BAT document - German Breweries*, 2013.
- [231] SUSCLEAN, *Sustainable cleaning and disinfection technologies*, 2015.
- [232] World Bank Group, Introduction to Wastewater Treatment Processes. <http://water.worldbank.org/shw-resource-guide/infrastructure/menu-technical-options/wastewater-treatment> , 2016.
- [233] Denmark, Pressurized Steam Fluidbed Drying of sugar beet pulp , 2015.
- [234] Denmark, *Drying of sugar beet pulp*, 2015.
- [235] COM, *Kick-off Meeting for the review of the reference document on best available techniques for food, drink and milk industries. Meeting Report.*, 2015.
- [236] Masanet et al., *Energy efficiency improvement and cost saving opportunities for the fruit and vegetable processing industry*, 2008.
- [237] Sarco, Steam solutions. <https://www.spiraxsarco.com/global/en-MY/industries/food-and-beverage> , 2019.
- [238] Andritz, Potato peeling lines for higher peeling efficiency. http://www.andritzgouda.com/uploads/docs/AG_Potato_peeling_brochure_def_mail.pdf , 2019.

GETTING IN TOUCH WITH THE EU

In person

All over the European Union there are hundreds of Europe Direct information centres. You can find the address of the centre nearest you at: https://europa.eu/european-union/contact_en

On the phone or by email

Europe Direct is a service that answers your questions about the European Union. You can contact this service:

- by freephone: 00 800 6 7 8 9 10 11 (certain operators may charge for these calls),
- at the following standard number: +32 22999696, or
- by electronic mail via: https://europa.eu/european-union/contact_en

FINDING INFORMATION ABOUT THE EU

Online

Information about the European Union in all the official languages of the EU is available on the Europa website at:

https://europa.eu/european-union/index_en

EU publications

You can download or order free and priced EU publications from EU Bookshop at: <https://publications.europa.eu/en/publications>.

Multiple copies of free publications may be obtained by contacting Europe Direct or your local information centre (see https://europa.eu/european-union/contact_en).

The European Commission's science and knowledge service

Joint Research Centre

JRC Mission

As the science and knowledge service of the European Commission, the Joint Research Centre's mission is to support EU policies with independent evidence throughout the whole policy cycle.



EU Science Hub
ec.europa.eu/jrc



@EU_ScienceHub



EU Science Hub - Joint Research Centre



EU Science, Research and Innovation



EU Science Hub

