



EUROPEAN COMMISSION

## Integrated Pollution Prevention and Control

Reference Document on  
Best Available Techniques for the Manufacture of

# Organic Fine Chemicals

August 2006

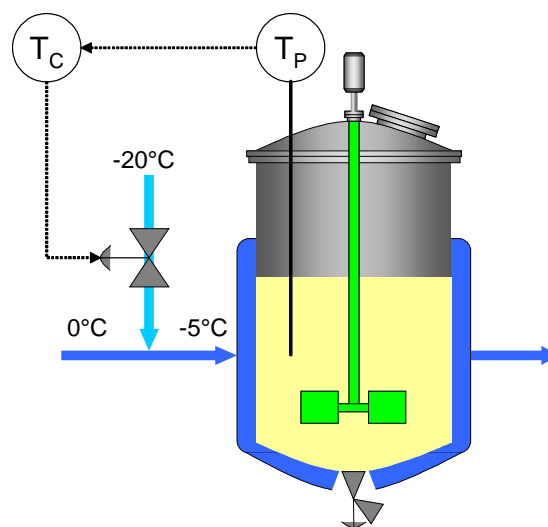

This document is one of a series of foreseen documents as below (at the time of writing, not all documents have been drafted):

<b>Reference Document on Best Available Techniques . . .</b>	<b>Code</b>
Large Combustion Plants	LCP
Mineral Oil and Gas Refineries	REF
Production of Iron and Steel	I&S
Ferrous Metals Processing Industry	FMP
Non Ferrous Metals Industries	NFM
Smitheries and Foundries Industry	SF
Surface Treatment of Metals and Plastics	STM
Cement and Lime Manufacturing Industries	CL
Glass Manufacturing Industry	GLS
Ceramic Manufacturing Industry	CER
Large Volume Organic Chemical Industry	LVOC
<i>Manufacture of Organic Fine Chemicals</i>	<i>OFC</i>
Production of Polymers	POL
Chlor – Alkali Manufacturing Industry	CAK
Large Volume Inorganic Chemicals - Ammonia, Acids and Fertilisers Industries	LVIC-AAF
Large Volume Inorganic Chemicals - Solid and Others industry	LVIC-S
Production of Speciality Inorganic Chemicals	SIC
Common Waste Water and Waste Gas Treatment/Management Systems in the Chemical Sector	CWW
Waste Treatments Industries	WT
Waste Incineration	WI
Management of Tailings and Waste-Rock in Mining Activities	MTWR
Pulp and Paper Industry	PP
Textiles Industry	TXT
Tanning of Hides and Skins	TAN
Slaughterhouses and Animals By-products Industries	SA
Food, Drink and Milk Industries	FDM
Intensive Rearing of Poultry and Pigs	ILF
Surface Treatment Using Organic Solvents	STS
Industrial Cooling Systems	CV
Emissions from Storage	ESB
<b>Reference Document . . .</b>	
General Principles of Monitoring	MON
Economics and Cross-Media Effects	ECM
Energy Efficiency Techniques	ENE

Electronic versions of draft and finalised documents are publically available and can be downloaded from <http://eippcb.jrc.es>.

## EXECUTIVE SUMMARY

The BAT (Best Available Techniques) Reference Document (BREF) entitled “Best Available Techniques for the Manufacture of Organic Fine Chemicals” (OFC) reflects an information exchange carried out under Article 16(2) of Council Directive 96/61/EC (IPPC Directive). This executive summary describes the main findings, a summary of the principal BAT conclusions and the associated consumption and emission levels. It should be read in conjunction with the preface, which explains this document’s objectives; how it is intended to be used and legal terms. It can be read and understood as a standalone document but, as a summary, it does not present all the complexities of this full document. It is therefore not intended as a substitute for this full document as a tool in BAT decision making.

This document focuses on the batch manufacture of organic chemicals in multipurpose plants and addresses the manufacture of a wide range of organic chemicals although not all of them are explicitly named in ANNEX 1 of the Directive. The list is not conclusive but includes, e.g. dyes and pigments, plant health products and biocides, pharmaceutical products (chemical and biological processes), organic explosives, organic intermediates, specialised surfactants, flavours, fragrances, pheromones, plasticisers, vitamins, optical brighteners and flame-retardants. No specific threshold was established in drawing a borderline to large volume production. Therefore it is implied that an OFC production site may also include dedicated production lines for “larger” volume products with batch, semi-batch or continuous operation.

### I. The sector and environmental issues

Organic fine chemical manufacturers produce a range of chemical substances, which are typically of a high added-value and produced in low volumes, mainly by batch processes in multipurpose plants. They are sold to companies, mostly other chemical companies, serving an immense range of end-user markets, on either a specification of purity or on their ability to deliver a particular effect. OFC manufacturers range in size from very small (<10 staff) to very large multinationals (>20000 staff), with typical manufacturing sites having between 150 and 250 staff.

The chemistry of fine organic intermediates and products shows an enormous diversity. But in reality, the number of operations/processes used remains reasonably small. These include charging/discharging of reactants and solvents, inertisation, reactions, crystallisations, phase separations, filtrations, distillation, product washing. In many cases cooling, heating, or the application of vacuum or pressure is necessary. The unavoidable waste streams are treated in recovery/abatement systems or disposed of as waste.

The key environmental issues of the OFC sector are emissions of volatile organic compounds, waste waters with potential for high loads of non-degradable organic compounds, relatively large quantities of spent solvents and non-recyclable waste in high ratio. Given the diversity of the sector, the wide range of chemicals produced and the enormous variety of possibly emitted substances, this document does not provide a comprehensive overview of the releases from the OFC sector. No data on consumption of raw materials, etc. were available. However, emission data are presented from a broad range of example plants in the OFC sector.

### II. Techniques to consider in the determination of BAT

The techniques to consider in the determination of BAT are grouped under the headings “Prevention and minimisation of environmental impact” (much related to the process design) and the “Management and treatment of waste streams”. The former includes strategies for the selection of the synthesis route, examples of alternative processes, equipment selection and plant design. The management of waste streams includes techniques for the assessment of waste stream properties and the understanding and monitoring of emissions. Finally, a wide range of recovery/abatement techniques for the treatment of waste gases, the pretreatment of waste water streams and the biological treatment of the total waste water are described.

### III. Best available techniques

The summary presented below does not include background statements and cross referencing which is found in the full text. Additionally, the full text contains BAT on environmental management. Where general BAT associated emission levels are given both in terms of concentration and mass flow, that which represents the greater amount in specific cases is intended as the BAT reference.

### Prevention and minimisation

#### **Integration of environmental considerations into process development**

BAT is to provide an auditable trail for the integration of environmental, health and safety considerations into process development. BAT is to carry out a structured safety assessment for normal operation and to take into account effects due to deviations of the chemical process and deviations in the operation of the plant. BAT is to establish and implement procedures and technical measures to limit risks from the handling and storage of hazardous substances and to provide sufficient and adequate training for operators who handle hazardous substances. BAT is to design new plants in such a way that emissions are minimised. BAT is to design, build, operate and maintain facilities, where substances (usually liquids) which represent a potential risk of contamination of ground and groundwater are handled, in such a way that spill potential is minimised. Facilities have to be sealed, stable and sufficiently resistant against possible mechanical, thermal or chemical stress. BAT is to enable leakages to be quickly and reliably recognised. BAT is to provide sufficient retention volumes to safely retain spills and leaking substances, fire fighting water and contaminated surface water in order to enable treatment or disposal.

#### **Enclosure of sources and airtightness of equipment**

BAT is to contain and enclose sources and to close any openings in order to minimise uncontrolled emissions. Drying should be carried out by using closed circuits, including condensers for solvent recovery. BAT is to use recirculation of process vapours where purity requirements allow this. To minimise the volume flow, BAT is to close any unnecessary openings in order to prevent air being sucked to the gas collection system via the process equipment. BAT is to ensure the airtightness of process equipment, especially of vessels. BAT is to apply shock inertisation instead of continuous inertisation. Still, continuous inertisation has to be accepted due to safety requirements, e.g. where processes generate O<sub>2</sub> or where processes require further loading of material after inertisation.

#### **Layout of distillation condensers**

BAT is to minimise the exhaust gas volume flows from distillations by optimising the layout of the condenser.

#### **Liquid addition to vessels, minimisation of peaks**

BAT is to carry out liquid addition to vessels as bottom feed or with dip-leg, unless reaction chemistry and/or safety considerations make it impractical. In such cases, the addition of liquid as top feed with a pipe directed to the wall reduces splashing and hence, the organic load in the displaced gas. If both solids and an organic liquid are added to a vessel, BAT is to use solids as a blanket in circumstances where the density difference promotes the reduction of the organic load in the displaced gas, unless reaction chemistry and/or safety considerations make it impractical. BAT is to minimise the accumulation of peak loads and flows and related emission concentration peaks by, e.g. optimisation of the production matrix and application of smoothing filters.

#### **Alternative techniques for product work-up**

BAT is to avoid mother liquors with high salt content or to enable the work-up of mother liquors by the application of alternative separation techniques, e.g. membrane processes, solvent-based processes, reactive extraction, or to omit intermediate isolation. BAT is to apply countercurrent product washing where the production scale justifies the introduction of the technique.

**Vacuum, cooling and cleaning**

BAT is to apply water-free vacuum generation by using, e.g. dry running pumps, liquid ring pumps using solvents as the ring medium or closed cycle liquid ring pumps. However, where the applicability of these techniques is restricted, the use of steam injectors or water ring pumps is justified. For batch processes, BAT is to establish clear procedures for the determination of the desired end point of the reaction. BAT is to apply indirect cooling. However, indirect cooling is not applicable for processes which require the addition of water or ice to enable safe temperature control, temperature jumps or temperature shock. Direct cooling can also be required to control “run away” situations or where there are concerns about blocking heat-exchangers. BAT is to apply a pre-rinsing step prior to rinsing/cleaning of equipment to minimise organic loads in wash-waters. Where different materials are frequently transported in pipes, the use of pigging technology represents another option to reduce product losses within cleaning procedures.

**Management and treatment of waste streams****Mass balances and analysis of waste streams**

BAT is to establish mass balances for VOCs (including CHCs), TOC or COD, AOX or EOX (Extractable Organic Halogen) and heavy metals on a yearly basis. BAT is to carry out a detailed waste stream analysis in order to identify the origin of the waste stream and a basic data set to enable management and suitable treatment of exhaust gases, waste water streams and solid residues. BAT is to assess at least the parameters given in Table I for waste water streams, unless the parameter can be seen as irrelevant from a scientific point of view.

Parameter	
Volume per batch	Standard
Batches per year	
Volume per day	
Volume per year	
COD or TOC	
BOD <sub>5</sub>	
pH	
Bioeliminability	
Biological inhibition, including nitrification	
AOX	
CHCs	
Solvents	
Heavy metals	
Total N	
Total P	
Chloride	
Bromide	
SO <sub>4</sub> <sup>2-</sup>	
Residual toxicity	

**Table I: Parameters for the assessment of waste water streams**

**Monitoring of emissions to air**

Emission profiles should be recorded instead of levels derived from short sampling periods. Emission data should be related to the operations responsible. For emissions to air, BAT is to monitor the emission profile which reflects the operational mode of the production process. In the case of a non-oxidative abatement/recovery system, BAT is to apply a continuous monitoring system (e.g. Flame Ionisation Detector, FID), where exhaust gases from various processes are treated in a central recovery/abatement system. BAT is to individually monitor substances with ecotoxicological potential if such substances are released.

### **Individual volume flows**

BAT is to assess the individual exhaust gas volume flows from process equipment to recovery/abatement systems.

### **Re-use of solvents**

BAT is to re-use solvents as far as purity requirements allow. This is carried out by using the solvent from previous batches of a production campaign for future batches, collecting spent solvents for on-site or off-site purification and re-use, or collecting spent solvents for on-site or off-site utilisation of the calorific value.

### **Selection of VOC treatment techniques**

One or a combination of techniques can be applied as a recovery/abatement system for a whole site, an individual production building, or an individual process. This depends on the particular situation and affects the number of point sources. BAT is to select VOC recovery and abatement techniques according to the flow scheme in Figure I.

### **Non-oxidative VOC recovery or abatement: achievable emission levels**

Where non-oxidative VOC recovery or abatement techniques are applied, BAT is to reduce emissions to the levels given in Table II.

### **Thermal oxidation/incineration or catalytic oxidation: achievable emission levels**

Where thermal oxidation/incineration or catalytic oxidation are applied, BAT is to reduce VOC emissions to the levels given in Table III.

### **Recovery/abatement of NO<sub>x</sub>**

For thermal oxidation/incineration or catalytic oxidation, BAT is to achieve the NO<sub>x</sub> emission levels given in Table IV and, where necessary, to apply a DeNO<sub>x</sub> system (e.g. SCR or SNCR) or two stage combustion to achieve such levels. For exhaust gases from chemical production processes, BAT is to achieve the NO<sub>x</sub> emission levels given in Table IV and, where necessary to apply treatment techniques such as scrubbing or scrubber cascades with scrubber media such as H<sub>2</sub>O and/or H<sub>2</sub>O<sub>2</sub> to achieve such levels. Where NO<sub>x</sub> from chemical processes is absorbed from strong NO<sub>x</sub> streams (about 1000 ppm and higher) a 55 % HNO<sub>3</sub> can be obtained for on-site or off-site re-use. Often, exhaust gases containing NO<sub>x</sub> from chemical processes also contain VOCs and can be treated in a thermal oxidiser/incinerator, e.g. equipped with a DeNO<sub>x</sub> unit or built as a two stage combustion (where already available on-site).

### **Recovery/abatement of HCl, Cl<sub>2</sub>, HBr, NH<sub>3</sub>, SO<sub>x</sub> and cyanides**

HCl can be efficiently recovered from exhaust gases with high HCl concentrations, if the production volume justifies the investment costs for the required equipment. Where HCl recovery is not preceded by VOC removal, potential organic contaminants (AOX) have to be considered in the recovered HCl. BAT is to achieve the emission levels given in Table VI and, where necessary, to apply one or more scrubbers using suitable scrubbing media.

### **Removal of particulates**

Particulates are removed from various exhaust gases. The choice of recovery/abatement systems depends strongly on the particulate properties. BAT is to achieve particulate emission levels of 0.05 – 5 mg/m<sup>3</sup> or 0.001 – 0.1 kg/hour and, where necessary, to apply techniques such as bag filters, fabric filters, cyclones, scrubbing, or wet electrostatic precipitation (WESP) in order to achieve such levels.

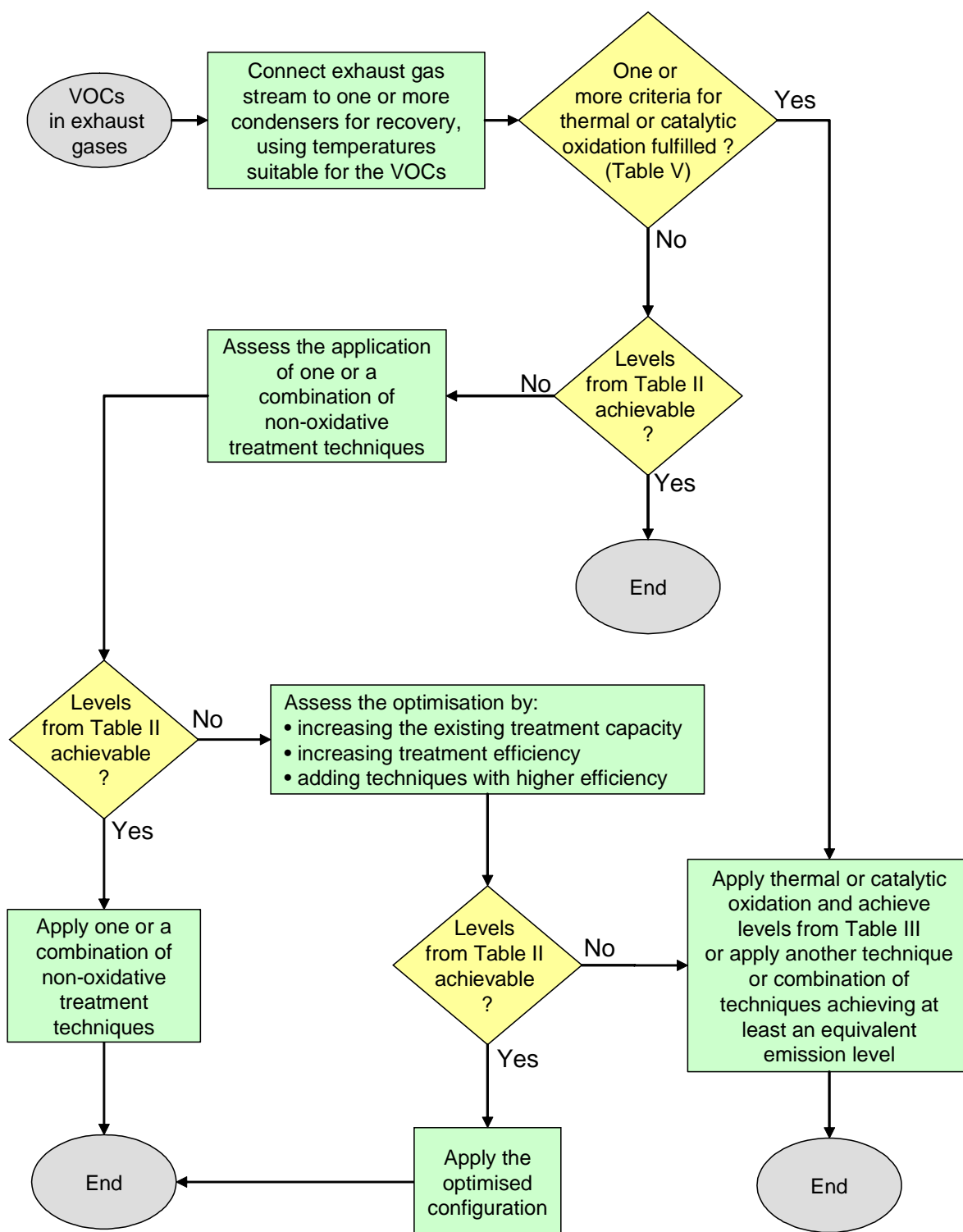

Figure I: BAT for the selection of VOC recovery/abatement techniques

Parameter	Average emission level from point sources*
Total organic C	0.1 kg C/hour or 20 mg C/m <sup>3</sup> **
* The averaging time relates to the emission profile, the levels relate to dry gas and Nm <sup>3</sup>	
** The concentration level relates to volume flows without dilution by, e.g. volume flows from room or building ventilation	

Table II: BAT associated VOC emission levels for non-oxidative recovery/abatement techniques

Thermal oxidation/incineration or catalytic oxidation	Average mass flow kg C/hour		Average concentration mg C/m <sup>3</sup>
Total organic C	<0.05	or	<5
The averaging time relates to the emission profile, levels relate to dry gas and Nm <sup>3</sup>			

**Table III: BAT associated emission levels for total organic C for thermal oxidation/incineration or catalytic oxidation**

Source	Average kg/hour <sup>*</sup>		Average mg/m <sup>3</sup> <sup>*</sup>	Comment
Chemical production processes, e.g. nitration, recovery of spent acids	0.03 – 1.7	or	7 – 220 <sup>**</sup>	The lower end of the range relates to low inputs to the scrubbing system and scrubbing with H <sub>2</sub> O. With high input levels, the lower end of the range is not achievable even with H <sub>2</sub> O <sub>2</sub> as the scrubbing medium
Thermal oxidation/incineration, catalytic oxidation	0.1 – 0.3		13 – 50 <sup>***</sup>	
Thermal oxidation/incineration, catalytic oxidation, input of nitrogenous organic compounds			25 – 150 <sup>***</sup>	Lower range with SCR, upper range with SNCR
<sup>*</sup> NO <sub>x</sub> expressed as NO <sub>2</sub> , the averaging time relates to the emission profile <sup>**</sup> Levels relate to dry gas and Nm <sup>3</sup> <sup>***</sup> Levels relate to dry gas and Nm <sup>3</sup>				

**Table IV: BAT associated NO<sub>x</sub> emission levels**

	Selection criteria
<b>a</b>	The exhaust gas contains very toxic, carcinogenic or cmr category 1 or 2 substances, or
<b>b</b>	autothermal operation is possible in normal operation, or
<b>c</b>	overall reduction of primary energy consumption is possible in the installation (e.g. secondary heat option)

**Table V: Selection criteria for catalytic and thermal oxidation/incineration**

Parameter	Concentration		Mass flow
HCl	0.2 – 7.5 mg/m <sup>3</sup>	or	0.001 – 0.08 kg/hour
Cl <sub>2</sub>	0.1 – 1 mg/m <sup>3</sup>		
HBr	<1 mg/m <sup>3</sup>		
NH <sub>3</sub>	0.1 – 10 mg/m <sup>3</sup>		0.001 – 0.1 kg/hour
NH <sub>3</sub> from SCR or SNCR	<2 mg/m <sup>3</sup>		<0.02 kg/hour
SO <sub>x</sub>	1 – 15 mg/m <sup>3</sup>		0.001 – 0.1 kg/hour
Cyanides as HCN	1 mg/m <sup>3</sup>		3 g/hour

**Table VI: BAT associated emission levels for HCl, Cl<sub>2</sub>, HBr, NH<sub>3</sub>, SO<sub>x</sub> and cyanides**



**Typical waste water streams for segregation and selective pretreatment**

BAT is to segregate and pretreat or dispose of mother liquors from halogenations and sulphochlorinations. BAT is to pretreat waste water streams containing biologically active substances at levels which could pose a risk either to a subsequent waste water treatment or to the receiving environment after discharge. BAT is to segregate and collect separately spent acids, e.g. from sulphonations or nitrations for on-site or off-site recovery or to apply BAT about pretreatment of refractory organic loadings.

**Pretreatment of waste water streams with refractory organic loadings**

BAT is to segregate and pretreat waste water streams containing relevant refractory organic loadings according to this classification: Refractory organic loading is not relevant if the waste water stream shows a bioeliminability of greater than about 80 - 90 %. In cases with lower bioeliminability, the refractory organic loading is not relevant if it is lower than the range of about 7.5 - 40 kg TOC per batch or per day. For the segregated waste water streams, BAT is to achieve overall COD elimination rates for the combination of pretreatment and biological treatment of >95 %.

**Recovery of solvents from waste water streams**

BAT is to recover solvents from waste water streams for on-site or off-site re-use, where the costs for biological treatment and purchase of fresh solvents are higher than the costs for recovery and purification. This is carried out by using techniques such as stripping, distillation/rectification, extraction or combinations of such techniques. BAT is to recover solvents from waste water streams in order to use the calorific value if the energy balance shows that overall natural fuel can be substituted.

**Removal of halogenated compounds from waste water streams**

BAT is to remove purgeable CHCs from waste water streams, e.g. by stripping, rectification or extraction and to achieve levels given in Table VII. BAT is to pretreat waste water streams with significant AOX loads and to achieve the AOX levels given in Table VII in the inlet to the on-site biological Waste Water Treatment Plant (WWTP) or in the inlet to the municipal sewerage system.

**Removal of heavy metals from waste water streams**

BAT is to pretreat waste water streams containing significant levels of heavy metals or heavy metal compounds from processes where they are used deliberately and to achieve the heavy metal concentrations given in Table VII in the inlet to the on-site biological WWTP or in the inlet to the municipal sewerage system. If equivalent removal levels can be demonstrated in comparison with the combination of pretreatment and biological waste water treatment, heavy metals can be eliminated from the total effluent using only the biological waste water treatment process, provided that the biological treatment is carried out on-site and the treatment sludge is incinerated.

Parameter	Yearly average	Unit	Comment
AOX	0.5 - 8.5	mg/l	The upper range relates to cases where halogenated compounds are processed in numerous processes and the corresponding waste water streams are pretreated and/or where the AOX is very bioeliminable
Purgeable CHCs	<0.1		Alternatively achieve a sum concentration of <1 mg/l in the outlet from pretreatment
Cu	0.03 - 0.4		The upper ranges result from the deliberate use of heavy metals or heavy metal compounds in numerous processes and the pretreatment of waste water streams from such use
Cr	0.04 - 0.3		
Ni	0.03 - 0.3		
Zn	0.1 - 0.5		

**Table VII: BAT associated levels in the inlet to the on-site biological WWTP or in the inlet to the municipal sewerage system**

**Free cyanides**

BAT is to recondition waste water streams containing free cyanides in order to substitute raw materials where technically possible. BAT is to pretreat waste water streams containing significant loads of cyanides and to achieve a cyanide level of 1 mg/l or lower in the treated waste water stream or to enable safe degradation in a biological WWTP.

**Biological waste water treatment**

BAT is to treat effluents containing a relevant organic load, such as waste water streams from production processes, rinsing and cleaning water, in a biological WWTP. BAT is to ensure that the elimination in a joint waste water treatment is overall not poorer than in the case of on-site treatment. For biological waste water treatment, COD elimination rates of 93 – 97 % are typically achievable as a yearly average. It is important that a COD elimination rate cannot be understood as a standalone parameter, but is influenced by the production spectrum (e.g. production of dyes/pigments, optical brighteners, aromatic intermediates which create refractory loadings in most of the waste water streams on a site), the degree of solvent removal and the degree of pretreatment of refractory organic loadings. Depending on the individual situation, retrofitting of the biological WWTP is required in order to adjust, e.g. treatment capacity or buffer volume or the application of a nitrification/denitrification or a chemical/mechanical stage. BAT is to take full advantage of the biological degradation potential of the total effluent and to achieve BOD elimination rates above 99 % and yearly average BOD emission levels of 1 - 18 mg/l. The levels relate to the effluent after biological treatment without dilution, e.g. by mixing with cooling water. BAT is to achieve the emission levels given in Table VIII.

**Monitoring of the total effluent**

BAT is to regularly monitor the total effluent to and from the biological WWTP. BAT is to carry out regular biomonitoring of the total effluent after the biological WWTP where substances with ecotoxicological potential are handled or produced with or without intention. Where residual toxicity is identified as a concern (e.g. where fluctuations of the performance of the biological WWTP can be related to critical production campaigns), BAT is to apply online toxicity monitoring in combination with online TOC measurement.

Parameter	Yearly averages*		Comment
	Level	Unit	
COD	12 - 250	mg/l	
Total P	0.2 - 1.5		The upper range results from the production of mainly compounds containing phosphorus
Inorganic N	2 - 20		The upper range results from production of mainly organic compounds containing nitrogen or from, e.g. fermentation processes
AOX	0.1 - 1.7		The upper range results from numerous AOX relevant productions and pretreatment of waste water streams with significant AOX loads
Cu	0.007 - 0.1		The upper ranges result from the deliberate use of heavy metals or heavy metal compounds in numerous processes and the pretreatment of waste water streams from such use
Cr	0.004 - 0.05		
Ni	0.01 - 0.05		
Zn	– 0.1		
Suspended solids	10 - 20		
LID <sub>F</sub>	1 - 2		Dilution factor
LID <sub>D</sub>	2 - 4		
LID <sub>A</sub>	1 - 8		
LID <sub>L</sub>	3 - 16		
LID <sub>EU</sub>	1.5		
* The levels relate to the effluent after biological treatment without dilution, e.g. by mixing with cooling water			

**Table VIII: BAT for emissions from the biological WWTP**

#### **IV. Concluding remarks**

The information exchange on Best Available Techniques for the Manufacture of Organic Fine Chemicals was carried out from 2003 to 2005. The information exchange process was successful and a high degree of consensus was reached during and following the final meeting of the Technical Working Group. No split views were recorded. However, it has to be noted that increasing confidentiality concerns represented a considerable obstacle throughout the work.

The EC is launching and supporting, through its RTD programmes, a series of projects dealing with clean technologies, emerging effluent treatment and recycling technologies and management strategies. Potentially these projects could provide a useful contribution to future BREF reviews. Readers are therefore invited to inform the EIPPCB of any research results which are relevant to the scope of this document (see also the Preface of this document).



---

## PREFACE

### 1. Status of this document

Unless otherwise stated, references to “the Directive” in this document means the Council Directive 96/61/EC on integrated pollution prevention and control. As the Directive applies without prejudice to Community provisions on health and safety at the workplace, so does this document.

This document forms part of a series presenting the results of an exchange of information between EU Member States and industries concerned on best available technique (BAT), associated monitoring, and developments in them. It is published by the European Commission pursuant to Article 16(2) of the Directive, and must therefore be taken into account in accordance with Annex IV of the Directive when determining “best available techniques”.

### 2. Relevant legal obligations of the IPPC Directive and the definition of BAT

In order to help the reader understand the legal context in which this document has been drafted, some of the most relevant provisions of the IPPC Directive, including the definition of the term “best available techniques”, are described in this preface. This description is inevitably incomplete and is given for information only. It has no legal value and does not in any way alter or prejudice the actual provisions of the Directive.

The purpose of the Directive is to achieve integrated prevention and control of pollution arising from the activities listed in its Annex I, leading to a high level of protection of the environment as a whole. The legal basis of the Directive relates to environmental protection. Its implementation should also take account of other Community objectives such as the competitiveness of the Community’s industry thereby contributing to sustainable development.

More specifically, it provides for a permitting system for certain categories of industrial installations requiring both operators and regulators to take an integrated, overall look at the polluting and consuming potential of the installation. The overall aim of such an integrated approach must be to improve the management and control of industrial processes so as to ensure a high level of protection for the environment as a whole. Central to this approach is the general principle given in Article 3 that operators should take all appropriate preventative measures against pollution, in particular through the application of best available techniques enabling them to improve their environmental performance.

The term “best available techniques” is defined in Article 2(11) of the Directive as “the most effective and advanced stage in the development of activities and their methods of operation which indicate the practical suitability of particular techniques for providing in principle the basis for emission limit values designed to prevent and, where that is not practicable, generally to reduce emissions and the impact on the environment as a whole.” Article 2(11) goes on to clarify further this definition as follows:

“techniques” includes both the technology used and the way in which the installation is designed, built, maintained, operated and decommissioned;

“available” techniques are those developed on a scale which allows implementation in the relevant industrial sector, under economically and technically viable conditions, taking into consideration the costs and advantages, whether or not the techniques are used or produced inside the Member State in question, as long as they are reasonably accessible to the operator;

“best” means most effective in achieving a high general level of protection of the environment as a whole.

Furthermore, Annex IV of the Directive contains a list of “considerations to be taken into account generally or in specific cases when determining best available techniques... bearing in mind the likely costs and benefits of a measure and the principles of precaution and prevention”. These considerations include the information published by the Commission pursuant to Article 16(2).

Competent authorities responsible for issuing permits are required to take account of the general principles set out in Article 3 when determining the conditions of the permit. These conditions must include emission limit values, supplemented or replaced where appropriate by equivalent parameters or technical measures. According to Article 9(4) of the Directive, these emission limit values, equivalent parameters and technical measures must, without prejudice to compliance with environmental quality standards, be based on the best available techniques, without prescribing the use of any technique or specific technology, but taking into account the technical characteristics of the installation concerned, its geographical location and the local environmental conditions. In all circumstances, the conditions of the permit must include provisions on the minimisation of long-distance or transboundary pollution and must ensure a high level of protection for the environment as a whole.

Member States have the obligation, according to Article 11 of the Directive, to ensure that competent authorities follow or are informed of developments in best available techniques.

### **3. Objective of this Document**

Article 16(2) of the Directive requires the Commission to organise “an exchange of information between Member States and the industries concerned on best available techniques, associated monitoring and developments in them”, and to publish the results of the exchange.

The purpose of the information exchange is given in recital 25 of the Directive, which states that “the development and exchange of information at Community level about best available techniques will help to redress the technological imbalances in the Community, will promote the worldwide dissemination of limit values and techniques used in the Community and will help the Member States in the efficient implementation of this Directive.”

The Commission (Environment DG) established an information exchange forum (IEF) to assist the work under Article 16(2) and a number of technical working groups have been established under the umbrella of the IEF. Both IEF and the technical working groups include representation from Member States and industry as required in Article 16(2).

The aim of this series of documents is to reflect accurately the exchange of information which has taken place as required by Article 16(2) and to provide reference information for the permitting authority to take into account when determining permit conditions. By providing relevant information concerning best available techniques, these documents should act as valuable tools to drive environmental performance.

### **4. Information Sources**

This document represents a summary of information collected from a number of sources, including in particular the expertise of the groups established to assist the Commission in its work, and verified by the Commission services. All contributions are gratefully acknowledged.

### **5. How to understand and use this document**

The information provided in this document is intended to be used as an input to the determination of BAT in specific cases. When determining BAT and setting BAT-based permit conditions, account should always be taken of the overall goal to achieve a high level of protection for the environment as a whole.

The rest of this section describes the type of information that is provided in each section of the document.

Chapters 1 and 2 provide general information on the industrial sector concerned and on the industrial processes used within the sector. Chapter 3 provides data and information concerning current emission and consumption levels reflecting the situation in existing installations at the time of writing.

Chapter 4 describes in more detail the emission reduction and other techniques that are considered to be most relevant for determining BAT and BAT-based permit conditions. This information includes the consumption and emission levels considered achievable by using the technique, some idea of the costs and the cross-media issues associated with the technique, and the extent to which the technique is applicable to the range of installations requiring IPPC permits, for example new, existing, large or small installations. Techniques that are generally seen as obsolete are not included.

Chapter 5 presents the techniques and the emission and consumption levels that are considered to be compatible with BAT in a general sense. The purpose is thus to provide general indications regarding the emission and consumption levels that can be considered as an appropriate reference point to assist in the determination of BAT-based permit conditions or for the establishment of general binding rules under Article 9(8). It should be stressed, however, that this document does not propose emission limit values. The determination of appropriate permit conditions will involve taking account of local, site-specific factors such as the technical characteristics of the installation concerned, its geographical location and the local environmental conditions. In the case of existing installations, the economic and technical viability of upgrading them also needs to be taken into account. Even the single objective of ensuring a high level of protection for the environment as a whole will often involve making trade-off judgements between different types of environmental impact, and these judgements will often be influenced by local considerations.

Although an attempt is made to address some of these issues, it is not possible for them to be considered fully in this document. The techniques and levels presented in Chapter 5 will therefore not necessarily be appropriate for all installations. On the other hand, the obligation to ensure a high level of environmental protection including the minimisation of long-distance or transboundary pollution implies that permit conditions cannot be set on the basis of purely local considerations. It is therefore of the utmost importance that the information contained in this document is fully taken into account by permitting authorities.

### *Reference plants*

Apart from references to literature, this document refers frequently to reference plants. Due to widely spread confidentiality concerns, all reference plants are named with an alias (example: \*199D,O,X\*) where the number can be used to identify the reference plant throughout this document and the following letters indicate the production spectrum as follows:

- A API
- B Biocides and/or plant health products
- D Dyes and/or pigments
- E Explosives
- F Flavours and/or fragrances
- I Intermediates
- L Large integrated multiproduct site
- O Optical brighteners
- V Vitamins
- X Other OFC

A list of all reference plants is given in Table 9.1.

**6. Future review and update**

Since the best available techniques change over time, this document will be reviewed and updated as appropriate. All comments and suggestions should be made to the European IPPC Bureau at the Institute for Prospective Technological Studies at the following address:

Edificio Expo, c/ Inca Garcilaso, s/n, E-41092 Sevilla, Spain

Telephone: +34 95 4488 284

Fax: +34 95 4488 426

e-mail: [jrc-ipts-eippcb@ec.europa.eu](mailto:jrc-ipts-eippcb@ec.europa.eu)

Internet: <http://eippcb.jrc.es>



---

# Best Available Techniques Reference Document for the Manufacture of Organic Fine Chemicals

<b>EXECUTIVE SUMMARY</b> .....	<b>I</b>
<b>PREFACE</b> .....	<b>XI</b>
<b>SCOPE</b> .....	<b>XXVII</b>
<b>1 GENERAL INFORMATION</b> .....	<b>1</b>
1.1 The sector .....	1
1.2 Environmental issues .....	4
1.3 Some products .....	5
1.3.1 Organic dyes and pigments .....	5
1.3.1.1 Overview .....	5
1.3.1.2 Pigments .....	6
1.3.1.3 Economics .....	7
1.3.2 Active pharmaceutical ingredients (APIs).....	8
1.3.2.1 Overview .....	8
1.3.2.2 Legal requirements and process modifications .....	8
1.3.2.3 Economics .....	9
1.3.3 Vitamins .....	9
1.3.4 Biocides and plant health products.....	10
1.3.4.1 Overview .....	10
1.3.4.2 Process modifications in manufacturing crop protection agents .....	11
1.3.4.3 Economics of crop protection .....	12
1.3.5 Fragrances and flavours.....	13
1.3.6 Optical brighteners .....	14
1.3.7 Flame-retardants.....	15
1.3.8 Plasticisers .....	16
1.3.9 Explosives .....	17
<b>2 APPLIED PROCESSES AND TECHNIQUES</b> .....	<b>19</b>
2.1 Conception: unit processes and operations .....	19
2.1.1 Intermediates .....	20
2.1.2 Isomers and by-products .....	21
2.2 Multipurpose plants .....	22
2.3 Equipment and unit operations .....	24
2.3.1 Reactors .....	24
2.3.1.1 Liquid addition to reactors .....	25
2.3.2 Equipment and operations for product work-up .....	25
2.3.2.1 Drying .....	25
2.3.2.2 Liquid-solid separation .....	26
2.3.2.3 Distillation .....	26
2.3.2.4 Liquid-liquid extraction .....	26
2.3.3 Cooling .....	27
2.3.4 Cleaning .....	27
2.3.5 Energy supply.....	28
2.3.6 Vacuum systems.....	29
2.3.7 Recovery/abatement of exhaust gases .....	30
2.3.8 Recovery/abatement applied to waste water streams .....	31
2.3.9 Groundwater protection and fire fighting water .....	32
2.3.10 Solvent recovery .....	33
2.4 Site management and monitoring .....	34
2.4.1 Emission inventories and monitoring .....	34
2.4.2 Overview to sources and parameters/pollutants .....	35
2.4.2.1 Waste gas emissions .....	35
2.4.2.2 Solvents and volatile organic compounds.....	36
2.4.2.3 Waste water emissions .....	37
2.4.2.4 Biodegradability and elimination of organic compounds.....	38

2.5	Unit processes and connected operations .....	40
2.5.1	N-acylation.....	40
2.5.2	Alkylation with alkyl halides .....	41
2.5.3	Condensation .....	42
2.5.4	Diazotisation and azo coupling .....	43
2.5.5	Esterification.....	45
2.5.6	Halogenation.....	48
2.5.7	Nitration.....	51
2.5.8	Manufacture of nitrated alcohols .....	53
2.5.9	Oxidation with inorganic agents .....	54
2.5.10	Phosgenation .....	55
2.5.11	Reduction of aromatic nitro compounds.....	56
2.5.11.1	Catalytic reduction with hydrogen .....	56
2.5.11.2	Reduction with iron .....	57
2.5.11.3	Alkali sulphide reduction.....	58
2.5.11.4	Product work-up .....	58
2.5.12	Sulphonation.....	59
2.5.13	Sulphonation with SO <sub>3</sub> .....	61
2.5.14	Sulphochlorination with chlorosulphonic acid .....	63
2.5.15	Wittig reaction .....	65
2.5.16	Processes involving heavy metals .....	66
2.6	Fermentation .....	68
2.6.1	Operations.....	68
2.6.2	Environmental issues .....	70
2.7	Associated activities .....	72
2.7.1	Formulation.....	72
2.7.2	Extraction from natural materials .....	73
<b>3</b>	<b>CURRENT EMISSION AND CONSUMPTION LEVELS .....</b>	<b>75</b>
3.1	Emissions to air .....	75
3.1.1	VOC emissions: overview .....	75
3.1.2	Concentration values and DeNO <sub>x</sub> efficiencies .....	76
3.1.3	Mass flows .....	79
3.2	Waste water .....	82
3.2.1	Reported COD and BOD <sub>5</sub> emissions and elimination efficiencies .....	82
3.2.2	Reported emissions for inorganic parameters and related elimination efficiencies .....	85
3.2.3	Reported emission values for AOX and toxicities .....	87
3.3	Waste.....	88
<b>4</b>	<b>TECHNIQUES TO CONSIDER IN THE DETERMINATION OF BAT.....</b>	<b>89</b>
4.1	Prevention of environmental impact .....	90
4.1.1	Green chemistry.....	90
4.1.2	Integration of EHS considerations into process development.....	92
4.1.3	Example for a solvent selection guide .....	94
4.1.4	Examples for alternative synthesis and reaction conditions.....	98
4.1.4.1	Sulphonation with SO <sub>3</sub> in gas-liquid reaction.....	98
4.1.4.2	Dry acetylation of a naphthylamine sulphonic acid .....	99
4.1.4.3	Recycling instead of treatment/disposal of TPPO.....	100
4.1.4.4	Enzymatic processes versus chemical processes.....	103
4.1.4.5	Catalytic reduction.....	105
4.1.4.6	Microstructured reactor systems .....	106
4.1.4.7	Reactions in ionic liquids.....	108
4.1.4.8	Cryogenic reactions .....	110
4.1.4.9	Reactions in supercritical CO <sub>2</sub> .....	111
4.1.4.10	Substitution of butyllithium .....	113
4.1.5	Extraction from natural products .....	114
4.1.5.1	Extraction from natural products with liquid CO <sub>2</sub> .....	114
4.1.5.2	Countercurrent band extraction.....	115
4.1.5.3	Enabling the re-use of residual plant material from extraction .....	116
4.1.6	Safety assessment .....	117
4.1.6.1	Physico-chemical safety assessment of chemical reactions .....	117
4.1.6.2	About the prevention of runaway reactions .....	122
4.1.6.3	Useful links and further information.....	123
4.2	Minimisation of environmental impacts.....	124
4.2.1	A “state of the art” multipurpose plant .....	124

4.2.2	Site assessment before process launch .....	126
4.2.3	Precautions in the production of herbicides .....	128
4.2.4	Improvement of “letter acid” production.....	130
4.2.5	Water-free vacuum generation .....	132
4.2.6	Liquid ring vacuum pumps using solvents as the ring medium.....	134
4.2.7	Closed cycle liquid ring vacuum pumps.....	136
4.2.8	Pigging systems.....	137
4.2.9	Indirect cooling .....	140
4.2.10	Pinch methodology .....	141
4.2.11	Energetically coupled distillation.....	144
4.2.12	Optimised equipment cleaning (1).....	146
4.2.13	Optimised equipment cleaning (2).....	147
4.2.14	Minimisation of VOC emissions (1).....	148
4.2.15	Minimisation of VOC emissions (2).....	149
4.2.16	Airtightness of vessels .....	151
4.2.17	Shock inertisation of vessels .....	152
4.2.18	Liquid addition into vessels .....	154
4.2.19	Solid-liquid separation in closed systems .....	155
4.2.20	Minimisation of exhaust gas volume flows from distillation.....	156
4.2.21	Segregation of waste water streams .....	158
4.2.22	Countercurrent product washing .....	160
4.2.23	Example for reaction control: azo coupling .....	162
4.2.24	Avoidance of mother liquors with high salt contents.....	163
4.2.25	Reactive extraction.....	165
4.2.26	Use of pressure permeation in dye manufacture .....	166
4.2.27	Ground protection .....	168
4.2.28	Retention of fire fighting and contaminated surface water .....	170
4.2.29	Example: training of phosgenation operators.....	171
4.2.30	Example: Handling of phosgene .....	173
4.3	Management and treatment of waste streams .....	175
4.3.1	Balances and monitoring .....	176
4.3.1.1	Process waste stream analysis.....	176
4.3.1.2	Analysis of waste water streams .....	179
4.3.1.3	Refractory organic loading: Zahn-Wellens test.....	181
4.3.1.4	Mass balances for solvents (VOC), highly hazardous substances and heavy metals .....	183
4.3.1.5	TOC balance for waste water streams.....	185
4.3.1.6	AOX balance for waste water streams .....	187
4.3.1.7	Monitoring of exhaust gas volume flows from processes .....	189
4.3.1.8	Monitoring of waste gas emissions.....	190
4.3.2	Waste streams from unit processes.....	192
4.3.2.1	Waste streams from N-acylation.....	192
4.3.2.2	Waste streams from alkylations with alkyl halides .....	194
4.3.2.3	Waste streams from condensations .....	196
4.3.2.4	Waste streams from diazotisation and azo coupling .....	198
4.3.2.5	Waste streams from halogenation .....	203
4.3.2.6	Waste streams from nitrations.....	206
4.3.2.7	Waste streams from the reduction of aromatic nitro compounds .....	209
4.3.2.8	Waste streams from sulphonation .....	212
4.3.2.9	Waste streams from sulphonation with SO <sub>3</sub> .....	216
4.3.2.10	Waste streams from sulphochlorination.....	218
4.3.2.11	Waste water streams from fermentation.....	220
4.3.3	Recovery of aromatic solvents and lower alcohols .....	222
4.3.4	Re-use and recycling of solvents and by-products .....	226
4.3.5	Treatment of exhaust gases .....	227
4.3.5.1	Recovery of NO <sub>x</sub> from exhaust gases.....	227
4.3.5.2	Recovery of HCl from exhaust gases.....	229
4.3.5.3	Scrubbing of HCl from exhaust gases and related emission levels .....	232
4.3.5.4	Recovery of bromine and HBr from exhaust gases.....	234
4.3.5.5	Absorption of excess chlorine from exhaust gases.....	236
4.3.5.6	Condensation of VOCs from reactors and distillations.....	238
4.3.5.7	Thermal oxidation of VOCs and co-incineration of liquid waste.....	240
4.3.5.8	Co-incineration of halogenated waste solvents .....	244
4.3.5.9	Stripping and thermal oxidation of methanol.....	246
4.3.5.10	Strategy for prevention and abatement of VOC emissions .....	248
4.3.5.11	Recovery and abatement of acetylene.....	249
4.3.5.12	Catalytic oxidation of 1,2-dichloroethane.....	252

4.3.5.13	Coupled concentration and catalytic oxidation of VOCs .....	254
4.3.5.14	Non-thermal exhaust gas treatments .....	256
4.3.5.15	Induction of non-thermal plasma and catalytic oxidation of VOCs .....	258
4.3.5.16	Minimising emission concentration peaks .....	259
4.3.5.17	Management of a modular exhaust gas treatment setup.....	261
4.3.5.18	Selection of a VOC treatment and emission levels .....	264
4.3.5.19	NO <sub>x</sub> : recovery, abatement and emission levels .....	268
4.3.5.20	Scrubbing of NH <sub>3</sub> from exhaust gases and related emission levels.....	272
4.3.5.21	Scrubbing of SO <sub>x</sub> from exhaust gases and related emission levels.....	274
4.3.5.22	Particulate removal from exhaust gases .....	276
4.3.6	Destruction of free cyanides .....	277
4.3.6.1	Destruction of free cyanides with NaOCl .....	277
4.3.6.2	Destruction of free cyanides with H <sub>2</sub> O <sub>2</sub> .....	279
4.3.7	Management and treatment of waste water streams.....	281
4.3.7.1	Pretreatment of waste water streams by separation.....	281
4.3.7.2	Pretreatment of waste water streams by oxidation.....	283
4.3.7.3	Pretreatment options for waste water streams on an OFC plant.....	285
4.3.7.4	Joint pretreatment of waste water streams by wet oxidation with O <sub>2</sub> .....	287
4.3.7.5	Pretreatment on production sites for biocides/plant health products.....	291
4.3.7.6	Management of waste water streams (1).....	293
4.3.7.7	Management of waste water streams (2).....	295
4.3.7.8	Management of waste water streams (3).....	297
4.3.7.9	Waste water streams for obligatory pretreatment or disposal .....	298
4.3.7.10	Refractory organic loadings (1) .....	300
4.3.7.11	Refractory organic loadings (2) .....	302
4.3.7.12	Refractory organic loadings (3) .....	303
4.3.7.13	Refractory organic loadings (4) .....	304
4.3.7.14	AOX elimination from waste water streams (1) .....	306
4.3.7.15	AOX elimination from waste water streams (2) .....	309
4.3.7.16	AOX elimination from waste water streams (3) .....	311
4.3.7.17	AOX: removal of iodine compounds from waste water streams by means of nanofiltration .....	313
4.3.7.18	Removal of CHCs and solvents from waste water streams.....	314
4.3.7.19	Removal of CHCs from waste water streams (2).....	316
4.3.7.20	Removal of CHCs from waste water streams (3).....	318
4.3.7.21	Removal of nickel from process waters .....	319
4.3.7.22	Heavy metals removal from waste water streams .....	321
4.3.7.23	Recovery of iodine from waste water streams .....	324
4.3.7.24	Disposal of waste water streams containing high P loads.....	325
4.3.8	Treatment of the total effluent and related emission levels.....	326
4.3.8.1	Achievable values for heavy metals in the total effluent .....	326
4.3.8.2	Pretreatment of the total effluent by chemical oxidation with H <sub>2</sub> O <sub>2</sub> .....	327
4.3.8.3	On-site instead of off-site biological WWTP.....	329
4.3.8.4	Joint treatment with municipal waste water.....	330
4.3.8.5	Proving the efficiency of off-site waste water treatment.....	332
4.3.8.6	Treatment of the total effluent .....	333
4.3.8.7	Protection and performance of biological WWTPs (1).....	335
4.3.8.8	Protection and performance of biological WWTPs (2).....	337
4.3.8.9	COD elimination rates: waste water streams .....	339
4.3.8.10	Understanding COD emission levels and elimination rates .....	340
4.3.8.11	BOD elimination rates and emission levels .....	344
4.3.8.12	AOX elimination rates and emission levels .....	346
4.3.8.13	LID emission levels .....	348
4.3.8.14	Nitrogen emission levels.....	350
4.3.8.15	Elimination of inorganic nitrogen from waste waters .....	352
4.3.8.16	Elimination of phosphorus compounds from waste waters.....	353
4.3.8.17	Phosphorus emission levels .....	354
4.3.8.18	Biomonitoring of effluents from active ingredient production .....	356
4.3.8.19	WEA as a management tool for treatment of waste water streams .....	358
4.3.8.20	Online monitoring of toxicity and TOC.....	359
4.3.8.21	Monitoring of the total effluent before and after biological treatment.....	361
4.4	Environmental management tools .....	363
<b>5</b>	<b>BEST AVAILABLE TECHNIQUES .....</b>	<b>371</b>
5.1	Prevention and minimisation of environmental impact.....	373
5.1.1	Prevention of environmental impact.....	373
5.1.1.1	Integration of environmental, health and safety considerations into process development.....	373
5.1.1.2	Process safety and prevention of runaway reactions.....	374
5.1.2	Minimisation of environmental impact.....	375
5.1.2.1	Plant design .....	375

5.1.2.2	Ground protection and water retention options.....	375
5.1.2.3	Minimisation of VOC emissions.....	376
5.1.2.4	Minimisation of exhaust gas volume flows and loads.....	376
5.1.2.5	Minimisation of volume and load of waste water streams.....	378
5.1.2.6	Minimisation of energy consumption.....	379
5.2	Management and treatment of waste streams.....	380
5.2.1	Mass balances and process waste stream analysis.....	380
5.2.2	Re-use of solvents.....	382
5.2.3	Treatment of exhaust gases.....	382
5.2.3.1	Selection of VOC recovery/abatement techniques and achievable emission levels.....	382
5.2.3.2	Recovery/abatement of NO <sub>x</sub> .....	385
5.2.3.3	Recovery/abatement of HCl, Cl <sub>2</sub> and HBr/Br <sub>2</sub> .....	386
5.2.3.4	NH <sub>3</sub> emission levels.....	386
5.2.3.5	Removal of SO <sub>x</sub> from exhaust gases.....	386
5.2.3.6	Removal of particulates from exhaust gases.....	387
5.2.3.7	Removal of free cyanides from exhaust gases.....	387
5.2.4	Management and treatment of waste water streams.....	387
5.2.4.1	Typical waste water streams for segregation, pretreatment or disposal.....	387
5.2.4.2	Treatment of waste water streams with relevant refractory organic load.....	388
5.2.4.3	Removal of solvents from waste water streams.....	389
5.2.4.4	Removal of halogenated compounds from waste water streams.....	389
5.2.4.5	Pretreatment of waste water streams containing heavy metals.....	390
5.2.4.6	Destruction of free cyanides.....	391
5.2.4.7	Biological waste water treatment.....	391
5.2.4.8	Monitoring of the total effluent.....	393
5.3	Environmental management.....	394
<b>6</b>	<b>EMERGING TECHNIQUES.....</b>	<b>395</b>
6.1	Mixing improvement.....	395
6.2	Process intensification.....	397
6.3	Microwave Assisted Organic Synthesis.....	399
6.4	Constant flux reactor systems.....	401
<b>7</b>	<b>CONCLUDING REMARKS.....</b>	<b>405</b>
7.1	Quality of the information exchange.....	405
7.2	Recommendations for future work.....	406
	<b>REFERENCES.....</b>	<b>409</b>
<b>8</b>	<b>GLOSSARY.....</b>	<b>415</b>
8.1	Abbreviations and explanations.....	415
8.2	Dictionary.....	421
<b>9</b>	<b>ANNEXES.....</b>	<b>423</b>
9.1	Description of reference plants.....	423

---

## List of figures

Figure 1.1: Sectoral breakdown of EU chemical industry sales (2003).....	1
Figure 1.2: Number of enterprises and sales by employment size.....	2
Figure 1.3: Management of waste streams .....	4
Figure 1.4: Major chromophores of commercially important dyes .....	5
Figure 1.5: Main uses of organic pigments.....	6
Figure 1.6: Share of the world textile dye market attributable to major manufacturers .....	7
Figure 1.7: Share of the world organic pigments market attributable to main geographic regions .....	7
Figure 1.8: Examples of APIs.....	8
Figure 1.9: Use of vitamins by sectors.....	10
Figure 1.10: Examples of biocides and plant health products.....	11
Figure 1.11: European crop protection market in 2001 showing percentages .....	12
Figure 1.12: Western European market (EU and EFTA) by product sector, 2001 .....	12
Figure 1.13: Real growth in the Western European crop protection market, 1990 – 2001 .....	13
Figure 1.14: Examples of some fragrance and flavour substances .....	13
Figure 1.15: Examples of some optical brighteners.....	14
Figure 1.16: Examples of some flame-retardants .....	15
Figure 1.17: World market for brominated flame-retardant compounds by region .....	15
Figure 1.18: Market composition by flame-retardant material .....	16
Figure 1.19: Examples of some plasticisers.....	16
Figure 1.20: Examples of some organic explosives.....	17
Figure 2.1: Illustrative example of a synthesis using several unit processes .....	21
Figure 2.2: Typical layout for a multipurpose plant .....	22
Figure 2.3: Example for the utilisation of the vessels in a production building.....	23
Figure 2.4: Stirred tank reactor (conventional temperature control, left) and loop reactor (right).....	24
Figure 2.5: Example of an energy supply setup with two boilers .....	28
Figure 2.6: Typically applied recovery/abatement techniques for exhaust gases on OFC sites .....	30
Figure 2.7: Typically applied recovery/abatement techniques for waste water streams on OFC sites .....	31
Figure 2.8: Typically applied processing units for solvent recovery on OFC sites .....	33
Figure 2.9: Examples of aromatic compounds with a biodegradability of more than 80 % .....	39
Figure 2.10: Examples of aromatic compounds with a biodegradability of less than 80 % .....	39
Figure 2.11: Typical sequence of operations and related waste streams from N-acetylations.....	41
Figure 2.12: Diazotisation and azo coupling .....	43
Figure 2.13: Typical sequence of operations for diazotisation and azo coupling .....	44
Figure 2.14: Common esterification .....	45
Figure 2.15: Typical sequence of operations for esterification.....	46
Figure 2.16: Applied abatement techniques for the waste streams from esterification.....	47
Figure 2.17: Side chain chlorination of toluene derivates.....	49
Figure 2.18: Typical sequence of operations for the halogenation to distillable products .....	50
Figure 2.19: Typical sequence of operations for halogenation with precipitation of the products .....	50
Figure 2.20: Nitration of an aromatic compound.....	51
Figure 2.21: Typical sequence of operations for a nitration .....	52
Figure 2.22: Typical setup for the manufacture of nitrated alcohols .....	53
Figure 2.23: Catalytic reduction of aromatic nitro compounds .....	56
Figure 2.24: Typical sequence of operations for the reduction of an aromatic nitro compound.....	58
Figure 2.25: Sulphonation of an aromatic system.....	59
Figure 2.26: Typical sequence of operations for a sulphonation .....	60
Figure 2.27: Sulphonation with SO <sub>3</sub> .....	61
Figure 2.28: Sulphonation with SO <sub>3</sub> in liquid phase.....	62
Figure 2.29: Sulphonation with SO <sub>3</sub> in gas-liquid reaction .....	62
Figure 2.30: Sulphochlorination with chlorosulphonic acid .....	63
Figure 2.31: Typical sequence of operations for sulphochlorination.....	64
Figure 2.32: Typical sequences of operations for fermentations and downstream work-up.....	69
Figure 2.33: Applied abatement techniques for the waste streams from fermentation .....	71
Figure 3.1: Composition of VOC emissions from the OFC sector in Spain .....	75
Figure 4.1: Treatment steps for the disposal of TPPO .....	100
Figure 4.2: Steps in the conversion of TPPO to TPP.....	102
Figure 4.3: Overall balances for a Wittig reaction with and without recycling of TPPO .....	102
Figure 4.4: Five plate microreactor for the synthesis of a vitamin precursor .....	106

Figure 4.5: A supercritical reactor system.....	111
Figure 4.6: Safety assessment procedure .....	119
Figure 4.7: Iterative assessment strategy for normal operations .....	120
Figure 4.8: Assessment of two sites concerning transportation .....	126
Figure 4.9: Assessment of two sites concerning the waste streams from a new production .....	126
Figure 4.10: Example for vacuum generation without a resulting contamination of water.....	132
Figure 4.11: Layout for a liquid ring pump using i-propanol as the ring liquid.....	134
Figure 4.12: Typical characteristics of a pig in a pipe for industrial applications.....	137
Figure 4.13: Two hot streams.....	141
Figure 4.14: Hot composite curve .....	141
Figure 4.15: Composite curves showing the pinch and energy targets .....	141
Figure 4.16: Schematic representation of the systems above and below the pinch.....	142
Figure 4.17: Heat transfer across the pinch from heat sink to heat source .....	142
Figure 4.18: Energetically coupled distillation of DMF.....	144
Figure 4.19: Example for a closed distillation system.....	156
Figure 4.20: Segregation of waste water streams from a production building .....	158
Figure 4.21: Countercurrent product washing in the manufacture of TNT .....	160
Figure 4.22: Product separation using pressure permeation .....	166
Figure 4.23: Comparison of BOD/TOC ratio and Zahn-Wellens tests on mother liquors .....	181
Figure 4.24: Example for a TOC balance for waste water streams .....	185
Figure 4.25: Example of an AOX balance for waste water streams.....	187
Figure 4.26: Total organic C profile from two production lines sharing one abatement system.....	190
Figure 4.27: Recovery/abatement techniques for waste streams from N-acylations.....	192
Figure 4.28: Recovery/abatement techniques for waste streams from alkylation with alkyl halides .....	195
Figure 4.29: Recovery/abatement techniques for waste streams from condensations.....	196
Figure 4.30: Applied abatement techniques for waste streams from diazotation and azo coupling .....	198
Figure 4.31: Recovery/abatement techniques for waste streams from halogenations .....	203
Figure 4.32: Applied abatement techniques for the waste streams from nitration .....	207
Figure 4.33: Treatment of waste streams from the reduction of nitroaromatics.....	209
Figure 4.34: Applied abatement techniques for the waste streams from sulphonation .....	214
Figure 4.35: Applied abatement techniques for sulphonation with SO <sub>3</sub> .....	216
Figure 4.36: Treatment of waste streams from sulphochlorination .....	218
Figure 4.37: Toluene recovery .....	224
Figure 4.38: Recovery and separation of a toluene/methanol mixture .....	224
Figure 4.39: Toluene recovery from exhaust gases.....	225
Figure 4.40: Recovery of a toluene/methanol mixture from exhaust gases.....	225
Figure 4.41: Recovery of NO <sub>x</sub> from exhaust gases with a scrubber cascade.....	227
Figure 4.42: HCl recovery from flue-gas .....	229
Figure 4.43: Concentration values for HCl emissions from point sources.....	232
Figure 4.44: Mass flow values for HCl emissions from point sources.....	232
Figure 4.45: Scrubbing system for recovery/removal of HBr and Br <sub>2</sub> .....	234
Figure 4.46: Absorption of excess chlorine.....	236
Figure 4.47: Two stage condensation from a reactor .....	238
Figure 4.48: Modular thermal treatment plant for waste gases and liquid wastes.....	240
Figure 4.49: Stripping and thermal oxidation of methanol from waste water streams .....	246
Figure 4.50: Acetylene recovery system .....	249
Figure 4.51: Catalytic oxidation of an exhaust gas containing 1,2-dichloroethane .....	252
Figure 4.52: Coupled concentration and catalytic oxidation of VOCs.....	254
Figure 4.53: Smoothing of emission concentration peaks.....	259
Figure 4.54: Concentration values VOC emissions from OFC point sources .....	265
Figure 4.55: Mass flow values of VOC emissions from OFC point sources.....	265
Figure 4.56: Concentration values for NO <sub>x</sub> emissions from point sources .....	268
Figure 4.57: Mass flow values for NO <sub>x</sub> emissions from point sources.....	268
Figure 4.58: Effect of changed NO <sub>x</sub> setpoint for the SNCR in the case of *020A,I* .....	269
Figure 4.59: Concentration values for NH <sub>3</sub> emissions from point sources.....	272
Figure 4.60: Mass flow values for NH <sub>3</sub> emissions from point sources .....	272
Figure 4.61: Concentration values for SO <sub>x</sub> emissions from point sources.....	274
Figure 4.62: Mass flow values for SO <sub>x</sub> emissions from point sources .....	274
Figure 4.63: Concentration values for particulate emissions from point sources.....	276
Figure 4.64: Mass flow values for particulate emissions from point sources.....	276
Figure 4.65: Destruction of cyanides .....	277
Figure 4.66: Destruction of cyanides with H <sub>2</sub> O <sub>2</sub> .....	279
Figure 4.67: Pretreatment/treatment options established by *010A,B,D,I,X* .....	285

---

Figure 4.68: Joint pretreatment by wet oxidation with O <sub>2</sub> .....	287
Figure 4.69: Results of the assessment of waste water streams from an external origin .....	289
Figure 4.70: Management of waste water streams on the reference plants.....	293
Figure 4.71: Decision made in the reference plant .....	295
Figure 4.72: Decisions made in the reference plants .....	300
Figure 4.73: Decisions made in the reference plant.....	304
Figure 4.74: AOX concentrations of inlet to and discharge from biological WWTPs .....	307
Figure 4.75: Treatment of waste water streams containing AOX.....	309
Figure 4.76: Two stage membrane setup for the removal of AOX from waste water streams .....	311
Figure 4.77: Pretreatment of CHCs .....	316
Figure 4.78: Removal of nickel from process waters .....	319
Figure 4.79: Selection of waste water streams for heavy metal treatment.....	321
Figure 4.80: Treatment of the total effluent with two biological and one activated carbon stages.....	333
Figure 4.81: NH <sub>4</sub> -N emission levels for three selected periods from 2002 to 2004 .....	338
Figure 4.82: COD elimination rates and emission levels from biological WWTPs on OFC sites.....	341
Figure 4.83: COD elimination profile for the biological treatment of a total effluent.....	342
Figure 4.84: Input to and discharge from a biological WWTP on a multipurpose site.....	342
Figure 4.85: Volume flow to the biological WWTP of *043A,I* .....	342
Figure 4.86: BOD elimination rates related to the achieved BOD emission level.....	344
Figure 4.87: AOX elimination rates and emission levels .....	346
Figure 4.88: Toxicity values derived from assessment of the total effluent .....	348
Figure 4.89: Nitrogen emission levels after biological WWTP .....	350
Figure 4.90: Total P input and output levels to/from biological WWTPs on OFC sites.....	354
Figure 4.91: Average residual acute toxicity in the effluent of *040A,B,I* .....	356
Figure 4.92: Principle of online toxicity monitoring .....	359
Figure 5.1: BAT for the selection of VOC recovery/abatement techniques .....	384
Figure 6.1: Comparison of conventional temperature control and constant flux control.....	401



---

## List of tables

Table 1.1: Classification of dyes by use or method of application.....	5
Table 1.2: Restructuring of the major Western European dye manufacturers.....	8
Table 1.3: Economic data for the European pharmaceutical industries .....	9
Table 1.4: Compounds and groups classified as vitamins.....	10
Table 1.5: Pesticide groups according to the type of pest they control .....	11
Table 2.1: Main unit processes and unit operations used in industrial fine organic chemistry .....	19
Table 2.2: Examples for primary intermediates and intermediates .....	20
Table 2.3: Example for the formation of isomers and by-products.....	21
Table 2.4: Direct and indirect cooling.....	27
Table 2.5: Some pump types and their main environmental issues.....	29
Table 2.6: Typical instruments for establishing an emission inventory .....	34
Table 2.7: Overview to sources and pollutants for waste gas emissions.....	35
Table 2.8: Some solvents used in the OFC sector .....	36
Table 2.9: Limit values for the manufacture of pharmaceutical products in the VOC Directive .....	36
Table 2.10: Overview of the sources of waste water streams, contaminants and relevant parameters .....	37
Table 2.11: Selected test methods for the degradation of organic chemicals.....	38
Table 2.12: Example data for waste water streams from esterification.....	46
Table 2.13: Overview of oxidations with inorganic agents.....	54
Table 2.14: Example data for the waste streams from oxidations .....	54
Table 2.15: Comparison of some toxic gases.....	55
Table 2.16: Typical processes involving heavy metals .....	66
Table 2.17: Example data for a waste stream from processes involving heavy metals.....	67
Table 2.18: Example data for the waste streams from fermentation .....	70
Table 2.19: Typical examples of waste streams from formulation activities .....	72
Table 2.20: Typical examples for waste streams from extractions .....	73
Table 3.1: Concentrations and DeNO <sub>x</sub> efficiencies for emissions to air for selected parameters.....	78
Table 3.2: Mass flows values for the emissions from point sources .....	81
Table 3.3: COD and BOD <sub>5</sub> emissions, volume flows and elimination efficiencies .....	84
Table 3.4: Emission data for inorganic parameters and elimination efficiencies .....	86
Table 3.5: Emission values for AOX and toxicities .....	87
Table 3.6: Waste generated by 20 OFC companies in Catalonia, Spain .....	88
Table 4.1: Information breakdown for each technique described in this chapter.....	89
Table 4.2: Integration of environmental, health and safety aspects in process development.....	92
Table 4.3: Solvent selection guide from *016A,I.....	96
Table 4.4: Properties that were considered and scored in the solvent selection guide from *016A,I* .....	97
Table 4.5: Example for the creation of TPPO from a Wittig process.....	100
Table 4.6: Comparison of enzymatic and chemical processes .....	103
Table 4.7: Comparison of costs for a pilot production in a batch vessel and in the micro-reactor.....	107
Table 4.8: Effects due to deviations of chemical processes or the operation of the plant .....	121
Table 4.9: Precautions taken on the referenced herbicide production site .....	128
Table 4.10: Mass balance for the manufacture of J acid (conventional process) .....	130
Table 4.11: Revision of the H acid process.....	130
Table 4.12: Comparison of operating costs of two vacuum generation techniques .....	133
Table 4.13: Examples for the application of pigging systems.....	138
Table 4.14: Comparison of costs for a conventional and pigging pipeline system .....	138
Table 4.15: Illustrative example for exhaust gas volumes from inertisation.....	152
Table 4.16: Process modification to avoid salting out.....	163
Table 4.17: Environmental benefits of product separation by pressure permeation.....	166
Table 4.18: Measures to limit the risks arising from storage and handling of phosgene .....	174
Table 4.19: Process waste stream analysis, flow chart.....	176
Table 4.20: Process waste stream analysis, properties of the waste water streams .....	177
Table 4.21: Example for an analysis of a waste water stream from a multipurpose plant .....	179
Table 4.22: Mass balance for a chemical site.....	183
Table 4.23: Monitoring profile for individual substances (mg/m <sup>3</sup> , 30 min values).....	190
Table 4.24: Example for the treatment of waste streams from N-acetylation .....	192
Table 4.25: Examples for treatment of waste streams from alkylation with alkyl halides .....	194
Table 4.26: Examples for the treatment of waste streams from condensations.....	196
Table 4.27: Example data for waste streams from diazotisation and azo coupling .....	199
Table 4.28: Examples for waste streams from azo dye manufacture involving heavy metals .....	200
Table 4.29: Examples for mother liquors and wash-waters from diazotisation/azo coupling.....	201

Table 4.30: Examples for treatment of waste streams from halogenation .....	204
Table 4.31: Example data for the waste streams from nitration.....	206
Table 4.32: Treatment of waste streams from reduction of nitroaromatics .....	210
Table 4.33: Example data for waste streams from sulphonation .....	212
Table 4.34: Examples for waste water streams obtained from sulphonations .....	213
Table 4.35: Example for a waste stream from sulphochlorination .....	219
Table 4.36: Examples for the waste water streams from a fermentation unit.....	221
Table 4.37: NO <sub>x</sub> emissions from the recovery of NO <sub>x</sub> from exhaust gases .....	228
Table 4.38: Achieved waste gas emission levels after recovery of HCl .....	229
Table 4.39: Achieved waste water output levels from the final absorption stage.....	230
Table 4.40: Mass flow to the HCl recovery system.....	230
Table 4.41: Cost benefits from HCl recovery .....	231
Table 4.42: Emissions from a HBr/Br <sub>2</sub> recovery/removal system.....	235
Table 4.43: Achievable emission levels for thermal waste gas treatment.....	241
Table 4.44: Overview to limits and restrictions of thermal exhaust gas treatment .....	242
Table 4.45: Overview to economic costs and benefits of thermal waste gas treatment.....	242
Table 4.46: Calculation of cost savings from the substitution of natural gas .....	243
Table 4.47: Example for the assessment of PCDD/F, PCB and PAH levels from an incinerator operated at different temperatures with different residence times.....	244
Table 4.48: Operational data for stripping and thermal oxidation .....	247
Table 4.49: Operating costs for the combination of stripping and thermal oxidation.....	247
Table 4.50: Achieved emission level for 1,2-dichloroethane.....	252
Table 4.51: Achievable emission values for a modular abatement setup .....	262
Table 4.52: Examples for the VOC emission levels from scrubbers which were later replaced by thermal oxidation .....	264
Table 4.53: Examples for VOC concentrations and mass flows from point sources .....	264
Table 4.54: Cost estimation per removed tonne of VOC.....	266
Table 4.55: NO <sub>x</sub> emissions from thermal oxidisers/incinerators.....	269
Table 4.56: Urea consumption of a SNCR according to NO <sub>x</sub> setpoint .....	270
Table 4.57: NO <sub>x</sub> emission data from nitration and recovery of spent acids .....	270
Table 4.58: Achieved emission values after destruction of cyanides .....	277
Table 4.59: Operational data for the destruction of cyanides .....	278
Table 4.60: Achieved emission values after the destruction of cyanides.....	280
Table 4.61: Operational data for the destruction of cyanides with H <sub>2</sub> O <sub>2</sub> .....	280
Table 4.62: Typical examples for the assignment of waste water streams to treatment options.....	285
Table 4.63: Examples and results for waste water streams treated by wet oxidation with O <sub>2</sub> .....	288
Table 4.64: Operational data for the wet oxidation with O <sub>2</sub> on the *088I,X* site.....	290
Table 4.65: Operational data and performance of the ozonolysis.....	291
Table 4.66: Pretreatment of waste water streams from the production of biocides/plant health products.....	292
Table 4.67: Degradability/eliminability of a total effluent after pretreatment of individual waste water streams .....	296
Table 4.68: Waste water streams for obligatory pretreatment or disposal.....	298
Table 4.69: Example of the assessment of the refractory organic load from a process .....	300
Table 4.70: AOX elimination and resulting releases after biological waste water treatment .....	306
Table 4.71: Other examples for AOX elimination.....	307
Table 4.72: Illustration of the effect of pretreatment on the AOX input to the biological WWTP.....	309
Table 4.73: Typical properties of the waste water streams in the example case.....	311
Table 4.74: Removal of solvents from waste water streams in the example of *082A,I* .....	314
Table 4.75: Costs for precipitation and filtration of the regenerate in comparison to disposal costs.....	320
Table 4.76: Heavy metal removal from waste water streams and the resulting emission level.....	321
Table 4.77: Other examples for heavy metal removal and resulting emission levels .....	322
Table 4.78: Examples for waste water streams containing iodine .....	324
Table 4.79: P containing mother liquors for disposal .....	325
Table 4.80: Achievable values for heavy metals in the total effluent .....	326
Table 4.81: Examples for the application of chemical oxidation with H <sub>2</sub> O <sub>2</sub> .....	328
Table 4.82: Achievable emission values after biological WWTP .....	335
Table 4.83: Setup and N emission levels of the current biological WWTP before retrofitting .....	337
Table 4.84: Alternative treatment of the total effluent.....	340
Table 4.85: Factors with influence on COD elimination rates of biological WWTPs.....	341
Table 4.86: Monitoring plan performed in the reference plants .....	362
Table 5.1: Parameters for the assessment of waste water streams .....	381
Table 5.2: BAT associated VOC emission levels for non-oxidative recovery/abatement techniques .....	383

---

Table 5.3: BAT associated emission levels for total organic C for thermal oxidation/incineration or catalytic oxidation .....	383
Table 5.4: Selection criteria for catalytic and thermal oxidation/incineration .....	384
Table 5.5: BAT associated NO <sub>x</sub> emission levels .....	385
Table 5.6: BAT associated AOX levels in the inlet to the on-site biological WWTP or in the inlet to the municipal sewerage system .....	390
Table 5.7: BAT associated levels for heavy metals in the inlet to the on-site biological WWTP .....	390
Table 5.8: BAT for emissions from the biological WWTP.....	392
Table 7.1: Timing of the work on the BREF for Organic Fine Chemicals.....	405
Table 7.2: Recommendations for future work related to VOC emissions to air .....	406
Table 7.3: Subjects with too little information for an assessment within the BAT concept.....	407
Table 9.1: Description of reference plants .....	426



## SCOPE

The BREF on Organic Fine Chemicals (OFC) focuses on the batch manufacture of organic chemicals in multipurpose plants. Specifically this document targets the following sections from ANNEX 1 of the IPPC Directive:

- 4.1j Dyes and Pigments
- 4.4 Plant health products and biocides
- 4.5 Pharmaceutical products (chemical and biological processes)

and additionally

- 4.6 Explosives

as far as the manufacture of organic compounds is concerned.

Following the same theme of batch manufacture in multipurpose plants the following categories of chemicals are addressed in this document although not explicitly named in ANNEX 1:

- organic intermediates
- specialised surfactants
- flavours, fragrances, pheromones
- plasticisers
- vitamins (belonging to pharmaceuticals)
- optical brighteners (belonging to dyes and pigments)
- flame-retardants.

This list is not conclusive and no specific threshold was established in drawing a borderline to large volume production. Therefore it is implied that an OFC production site may also include dedicated production lines for “larger” volume products with batch, semi-batch or continuous operation.

The scope covers an enormous variety of produced substances. Therefore the document does not describe the production of specific, individual products but deals with environmentally relevant unit processes and unit operations, as well as with the usual infrastructure found at a typical site. The document cannot and is not intended to replace the chemical textbooks on “green chemistry” and indeed it gives only general guidance for the early stage of process design – and deals mainly with process modifications and especially with the management of unavoidable waste streams.

### **The interface to the BREF on CWW [31, European Commission, 2003]**

The BREF on “Common waste gas and waste water treatment/management systems in the chemical sector” describes techniques which are commonly applicable in the whole spectrum of the chemical industry. As a result, only generic conclusions were derived, which de facto could not take into account the specific characteristics of the manufacture of Organic Fine Chemicals.

Using the results of the BREF on CWW as a source of information, the BREF on OFC provides a further assessment of such techniques in the OFC context. The main aspect is the effect of the operational mode (batch manufacture, production campaigns, frequent product change) on the selection and the applicability of treatment techniques, as well as the implicit challenges of managing a multipurpose site. Furthermore the performance is assessed and conclusions are drawn based on OFC specific information and data.



## 1 GENERAL INFORMATION

### 1.1 The sector

[18, CEFIC, 2003]

The chemical industry substantially contributes to the EU economy, with sales of over EUR 519000 million and a trade surplus of EUR 65000 million, making it Europe's number one exporter. The chemical industry and all its sectors, especially the Organic Fine Chemicals (OFC) sector, is global in scope, competing on the world market with its products.

The chemical industry is Europe's third largest industry, employing 1.7 million people directly and with an additional 3 million jobs directly supporting the chemical industry. The OFC sector is estimated to employ over 0.6 million people with a turnover of EUR 125000 million. Typical employers include large multinationals with organic fine chemical business units, but over 90 % of all sector companies are either middle-sized or SMEs.

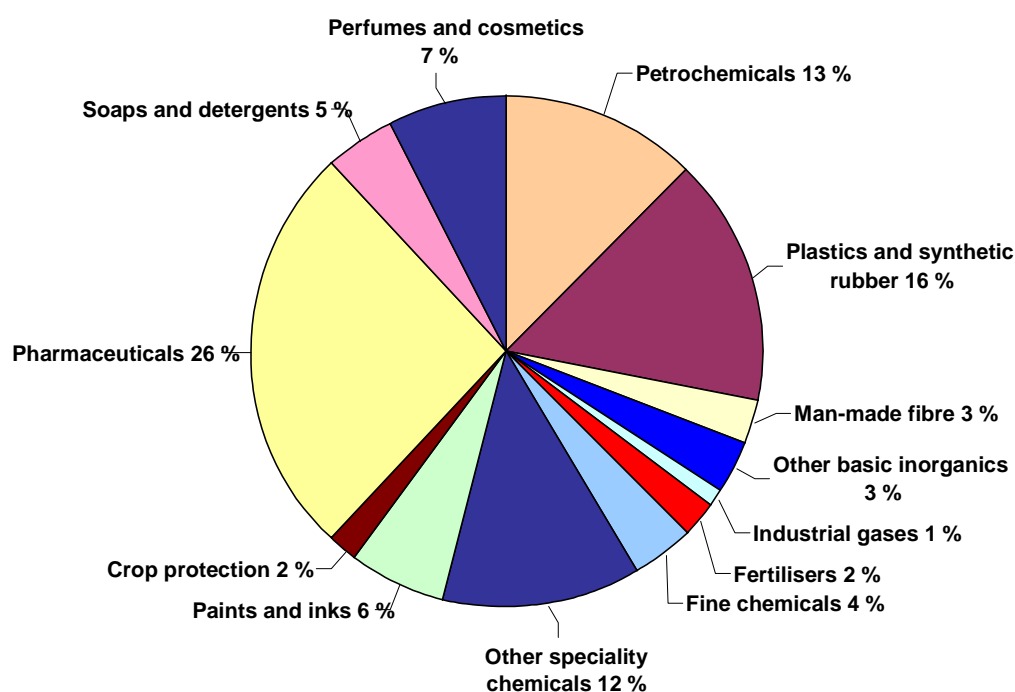
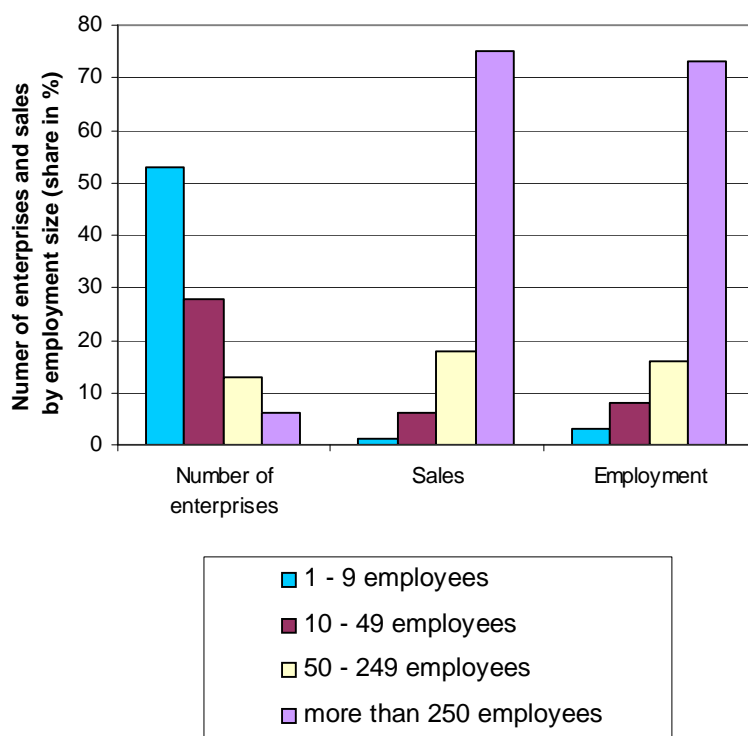

Figure 1.1: Sectoral breakdown of EU chemical industry sales (2003)

Other speciality and fine chemicals are produced in smaller volumes than base chemicals. Speciality chemicals cover the auxiliaries for industry, dyes & pigments, oleo-chemicals, crop protection, and paints & inks. Fine chemicals represent pharma-intermediates, agro-intermediates, and chemical intermediates. Pharmaceutical covers both basic pharmaceutical products and pharmaceutical preparations.

Organic fine chemical manufacturers produce a wide range of chemical substances, which are typically of a high added-value and produced in low volumes, mainly by batch processes in multipurpose plants. They are sold to companies, mostly other chemical companies, serving an immense range of end-user markets, on either a specification of purity or on their ability to deliver a particular effect. Typical major end-user markets are pharmaceuticals, agrochemicals, dyestuffs, flavours and fragrances, speciality polymers, electronics, food additives, and catalysts. Typical of the OFC sector is the manufacture of products or intermediates for internal use, in addition to external sales. The global market has grown at around 4 % per year and is currently valued at around EUR 265000 million (USD 300000 million). Demand patterns affecting typical European OFC manufacturers are:

- continued globalisation of major customers, e.g. pharmaceutical companies, consequently reducing the number of new chemical substances requiring contract manufacture
- continued shift of manufacturing activities to the Far East
- continued rationalisation of large multinationals, leading to more outsourcing of existing and new low volume substances
- increasing costs of regulation, affecting the cost base especially of smaller manufacturers.



**Figure 1.2: Number of enterprises and sales by employment size**

OFC manufacturers range in size from very small (<10 staff) to very large multinationals (>20000 staff), with typical manufacturing sites having between 150 and 250 staff.



It is a feature of the sector to complement manufacturing with special customer services such as synthesis, contract manufacture, research and screening and the supply of research and laboratory chemicals. Key attributes of OFC manufacturers are:

- strong management, supported by flexible technical and process skills
- strong application and customer services [99, D2 comments, 2005]
- adoption of international management systems, e.g. ISO 9001, ISO 14001, EMAS and a “Responsible Care Programme”
- ability to perform a range of complex chemistries at scales from kilos to tonnes
- unique technology platforms and willingness to adopt new, proven technologies
- well supported multi-functional assets capable of operating to cGMP when required
- regulatory and analytical infrastructure
- fast-track development and manufacture
- strategic commitment to custom synthesis manufacture
- flexibility and responsiveness
- strong ability of innovation and links with universities and research organisations
- significant efforts to replace hazardous substances [99, D2 comments, 2005].

## 1.2 Environmental issues

The key environmental issues of the OFC sector are:

- emission of volatile organic compounds
- waste waters with potential for high loads of non-degradable organic compounds
- relatively large quantities of spent solvents
- non-recyclable waste in high ratio.

The enormous variety of possibly handled (and emitted) substances also includes highly harmful compounds which may be toxic, suspected of being carcinogenic or being carcinogenic.

The following values may give an impression of the dimensions:

- if a new company with a solvent input of 10000 tonnes per year (which is not unusual) meets the limits of the VOC Directive, overall emissions of 500 tonnes VOC yearly are possible
- if the same company does not operate its own recycling/incineration facilities, the remaining portion of about 9500 tonnes spent solvents have to be disposed of
- for the same company, it would be not unusual to emit 50 tonnes COD yearly, representing organic compounds which were not degraded in the company's waste water treatment plant
- from a larger plant with a more "difficult" production spectrum, an annual emission of 1000 tonnes COD is possible.

### Prevention, minimisation and recovery/abatement of waste streams

The reaction itself and the operations carried out to purify or separate the product create a variety of waste streams (exhaust gases, mother liquors, wash-waters, spent solvents, spent catalysts, by-products) which have to be identified. If a particular waste stream cannot be avoided by process modification, it is a crucial challenge in the multipurpose plant to assign this waste stream to recovery or abatement facilities or to dispose of it as waste (Figure 1.3).

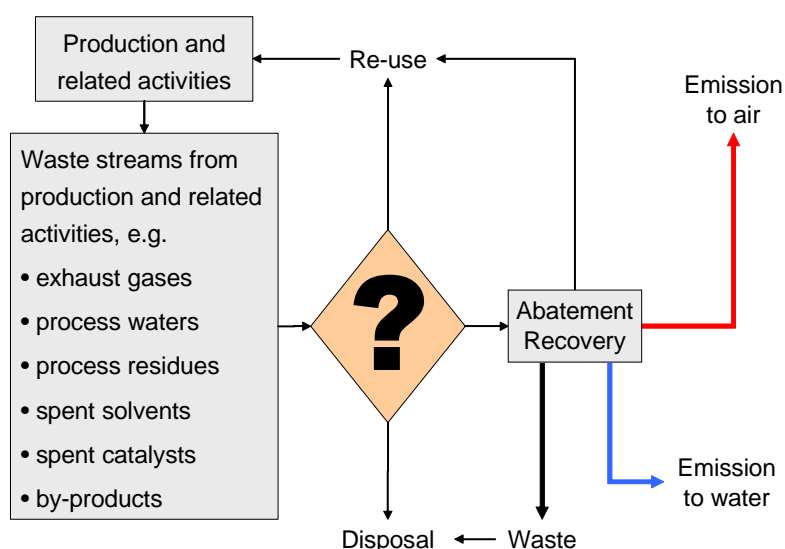

Figure 1.3: Management of waste streams

## 1.3 Some products

### 1.3.1 Organic dyes and pigments

[1, Hunger, 2003, 2, Onken, 1996, 6, Ullmann, 2001, 19, Booth, 1988, 20, Bamfield, 2001, 46, Ministerio de Medio Ambiente, 2003]

#### 1.3.1.1 Overview

Dyes and pigments can be classified according to their chemical structure or their mode of application. The most important commercial products are the azo, anthraquinone, sulphur, indigoid, triphenylmethane and phthalocyanine dyes. Figure 1.4 shows the major chromophores and Table 1.1 shows the classification of dyes by use or method of application.

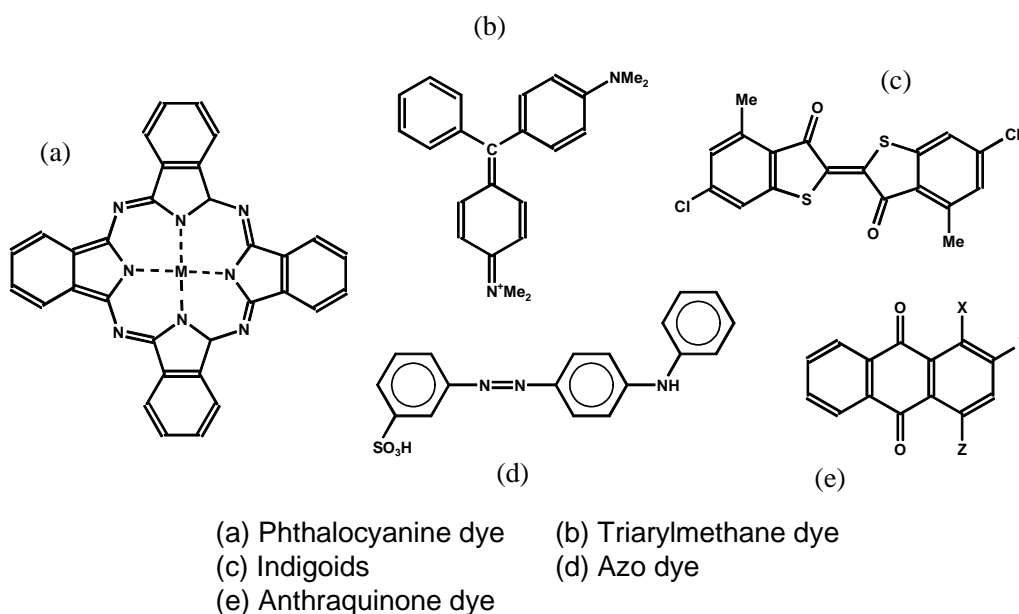

Figure 1.4: Major chromophores of commercially important dyes

Dyeing method	Preferred substrate/ typical application	Principal chemical class	Solubility in water
Reactive dyes	Cotton	Azo, metallised azo, phthalocyanine, anthraquinone	Soluble
Disperse dyes	Polyester, electronic photography	Non-ionic	Insoluble
Direct dyes	Cotton, regenerated cellulose	Anionic, poly-azo	Soluble
Vat dyes	Cellulose fibres	Anthraquinone, indigoids	Insoluble Soluble leuco salts
Sulphur dyes	Cotton	Sulphur dyes	Soluble
Cationic or basic dyes	Paper, polyacrylo nitril, polyesters	Triarylmethane	Soluble
Acid dyes	Nylon, wool, silk, leather, paper, ink-jets		Soluble
Solvent dyes	Plastics, gasoline, oils, waxes	Azo, anthraquinone	Insoluble

Table 1.1: Classification of dyes by use or method of application

Apart from one or two notable exceptions, all dye types used today were discovered in the 1880s. The introduction of the synthetic fibres such as nylon, polyester and polyacrylonitrile during the period 1930 – 1950, produced the next significant challenge. The discovery of reactive dyes in 1954 and their commercial launch heralded a major breakthrough in the dyeing of cotton. Intensive research into reactive dyes followed over the next two decades and is still continuing today.

One important theme in research today is the replacement of tinctorially weak chromogens, such as anthraquinone, with tinctorially stronger chromogens, such as (heterocyclic) azo dyes. Considerable activity is also being dedicated to high tech applications, especially in the electronics and non-impact printing industries.

### 1.3.1.2 Pigments

Pigments are defined as colouring agents that are practically insoluble in the application medium, whereas dyes are colouring agents that are soluble in the application medium.

In colouring, the crystalline pigment is applied in the solid state, not in the dissolved form, to the medium being coloured. Both the chemical and the physical properties of the pigments (e.g. particulate size, particulate size distribution, special types of surface and specific surface area, crystal modification, and crystal form) are important for their industrial application.

Many organic pigments and dyes have the same basic chemical structure. The insolubility required in pigments can be obtained by excluding solubilising groups, by forming insoluble salts (lake formation) of carboxylic or sulphonic acids, by metal complex formation in compounds without solubilising groups, and particularly by incorporating groups that reduce solubility (e.g. amide groups).

Figure 1.5 shows the largest areas of use of organic pigments.

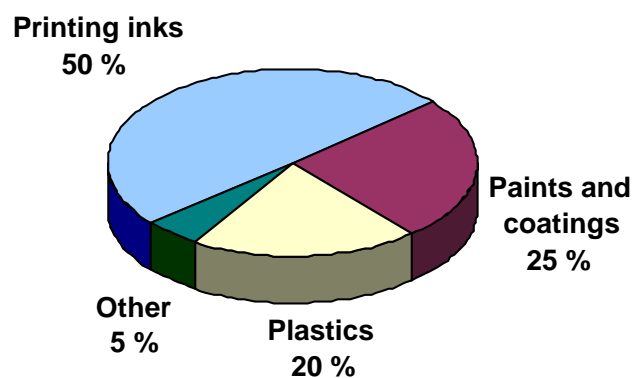

**Figure 1.5: Main uses of organic pigments**

The remaining organic pigments (“Other”) are used in textile printing and a number of smaller sectors, including contactless printing processes, office articles and accessories (e.g. coloured pencils, crayons, chalks), and the colouring of wood, cosmetics, and paper.

### 1.3.1.3 Economics

The scale and growth of the dyes industry is linked to that of the textile industry. World textile production has grown steadily to an estimated 35 million tonnes in 1990. The two most important textile fibres are cotton and polyester. Consequently, dye manufacturers tend to concentrate their efforts on producing dyes for these two fibres. The estimated world production of dyes and pigments in 1990 was 1 million tonnes. The rapid growth in the high tech uses of dyes, particularly in ink-jet printing, is beginning to make an impact. Although the volumes in this area remain small in comparison to dyes for traditional applications, the value will be significant because of the much higher price.

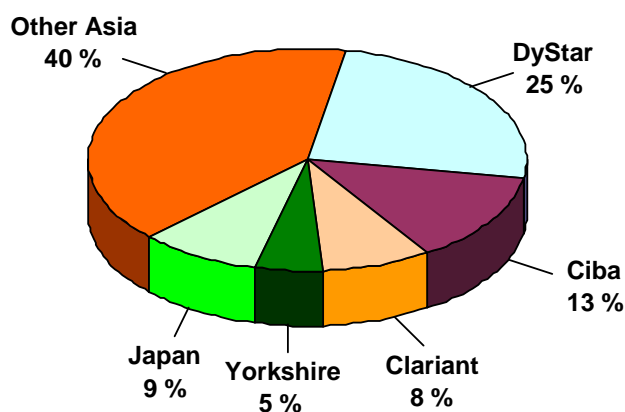

Figure 1.6: Share of the world textile dye market attributable to major manufacturers [20, Bamfield, 2001]

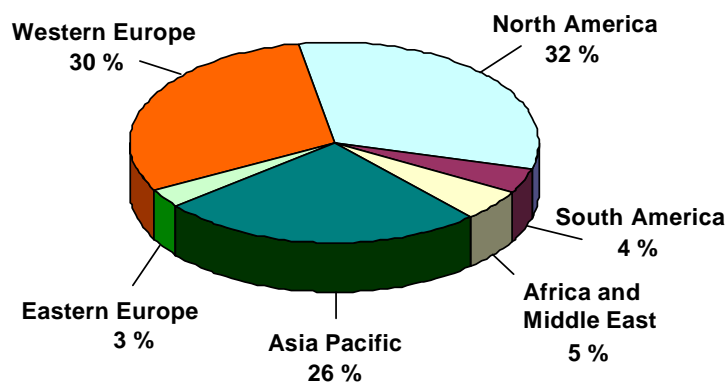

Figure 1.7: Share of the world organic pigments market attributable to main geographic regions [20, Bamfield, 2001]

The Western European share of world production has declined from 95 % in the early 1900s to about 40 %, taking into account that a large part of US manufacture and that of other countries is based on Western European subsidiaries. This decline is coupled with an increase of production in commodity dyestuffs in lower cost countries such as India, Taiwan and China. The world output of organic dyes is estimated to be 750000 tonnes per year [6, Ullmann, 2001].

The major European dye manufacturers have undergone major reorganisations, mergers and acquisitions to focus on “core” activities (Table 1.2).

Country	Current Company	Original companies
Germany	Dystar	Bayer, Hoechst, BASF, textile dyes from Zeneca
Switzerland	Clariant	Sandoz, Hoechst Speciality Chemicals
	Ciba Speciality Chemicals	Ciba-Geigy
UK	Avecia	ICI
	Yorkshire	Crompton and Knowles (US)

**Table 1.2: Restructuring of the major Western European dye manufacturers**  
[20, Bamfield, 2001]

### 1.3.2 Active pharmaceutical ingredients (APIs)

[2, Onken, 1996, 6, Ullmann, 2001, 21, EFPIA, 2003, 35, CEFIC, 2003]

#### 1.3.2.1 Overview

Active Pharmaceutical Ingredients (APIs) are based on organic molecules which have been synthesised and modified to provide medicinal products and comprise the largest segment of available drugs. Biotechnology is part of the pharmaceutical industry today, but drugs based on organic chemistry remain the largest part of R&D and comprise the largest percentage of new drugs launched yearly. Figure 1.8 gives some examples, but in reality the variety in the world is enormous.

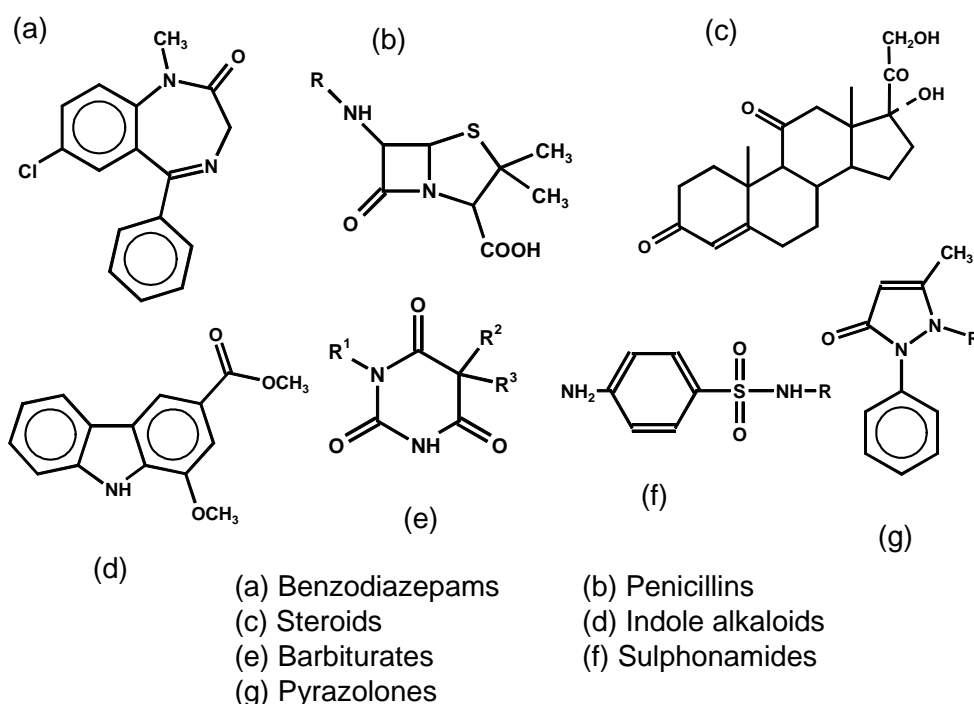

**Figure 1.8: Examples of APIs**

#### 1.3.2.2 Legal requirements and process modifications

Where API manufacture on a site requires the observance of the rules of current Good Manufacturing Practice (cGMP) or approval by the European Medicine Evaluation Agency (EMA), the United States Food and Drug Administration (FDA) or other applicable medicine approval authorities, process modifications can be only carried out fulfilling the required variation procedure. This represents a serious obstacle for the redesign of existing processes. This is even more the case if the API is supplied to a number of different marketing application holders (which is the case for about 75 % of the total volume of API production).

### 1.3.2.3 Economics

The pharmaceutical industry is a major industrial asset to the European economy, strongly research-based and one of the best performing high technology sectors. Europe produces more than 40 % of the world's pharmaceutical output by value, making it still the world's leading manufacturing location ahead of the US (over 30 %) and Japan (20 %).

	1985	1990	2000	2001
	<b>EUR millions</b>			
R&D expenditure	4300	7900	17000	18900
Pharmaceutical market value at manufacturer's prices	27600	42100	87000	98700
Pharmaceutical market value at retail prices	43200	67900	131000	151600
	<b>Employees</b>			
Employment	437600	505000	540000	582300

**Table 1.3: Economic data for the European pharmaceutical industries**  
[21, EFPIA, 2003]

Although Europe still leads the world in pharmaceutical manufacturing, the US has taken the lead in innovation in terms of R&D investments and the introduction of new pharmaceuticals, e.g. patenting biomedicines.

Like many other industries, the pharmaceutical industry is undergoing change. In addition to constantly assimilating new technologies into its research and adjusting to changing market and regulatory environments, a number of pharmaceutical company mergers are taking place.

The pharmaceutical industry is highly fragmented. The largest companies have less than 5 % of the worldwide market share for pharmaceuticals. Perhaps as a result, mergers and acquisitions have become more frequent. Some examples are the merger of the two British companies Glaxo and Wellcome; the merger of the life sciences operations of Hoechst, Marion Merrill Dow, Rousell, and Rorer in a series of transactions to form Aventis; Sanofi merged with Synthelabo; Novartis which was formed by a merger of the Swiss companies Ciba Geigy and Sandoz; and the merger of Astra and Zeneca to form AstraZeneca.

### 1.3.3 Vitamins

[2, Onken, 1996, 6, Ullmann, 2001]

Vitamins are essential, organic compounds which are either not synthesised in the human and animal organism or which are formed only in insufficient amounts. Pro-vitamins can be converted to the vitamin in the body. A typical representative of the pro-vitamins is  $\beta$ -carotene, which is split into two molecules of vitamin A in the organism.

Vitamins are classified not chemically but by their activity. The historical distinction between fat- and water-soluble vitamins has been retained to this day, since the solution properties are important not only for the occurrence, but also for the behaviour of vitamins in the organism (resorption, transport, excretory pathways, and storage).

Fourteen compounds or groups of compounds have been classified as vitamins (Table 1.4).

The worldwide market value for vitamins as a bulk product is estimated to be EUR 25600 million (DEM 50000 million) per year [6, Ullmann, 2001].

Compound/group	Chemical family	Single substance	Production in tonnes per year
<b>Vitamin A</b>	Retinols	Vitamin A <sub>1</sub>	2700
		β-carotene	100
		Other carotenoids	400
<b>Vitamin D</b>	Calciferols	Vitamin D <sub>3</sub>	25
<b>Vitamin E</b>	Tocopherols, tocotrienols	α-tocopherol	7000
<b>Vitamin K</b>	Phylloquinone		
<b>Vitamin B<sub>1</sub></b>	Thiamin		
<b>Vitamin B<sub>2</sub></b>	Riboflavin		2000
<b>Vitamin B<sub>3</sub></b>	Nicotinacid amide		12000
<b>Vitamin B<sub>6</sub></b>	Pyridoxal group		
<b>Vitamin B<sub>12</sub></b>	Cobalamins		12
<b>Vitamin C</b>	L-ascorbic acid		40000
<b>Pantothenic acid</b>			
<b>Biotin</b>			
<b>Folic acid</b>			
<b>Niacin</b>			

Table 1.4: Compounds and groups classified as vitamins

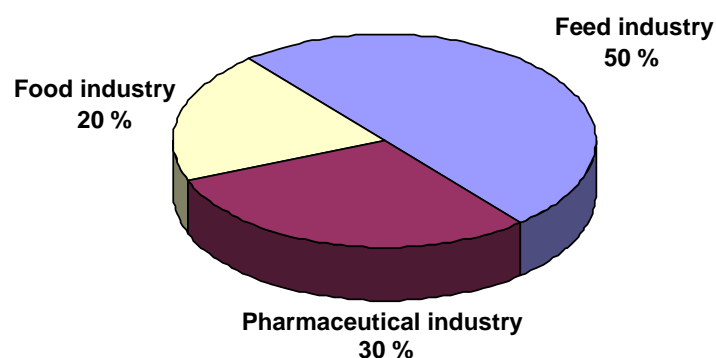
Figure 1.9: Use of vitamins by sectors  
[6, Ullmann, 2001]

### 1.3.4 Biocides and plant health products

#### 1.3.4.1 Overview

[2, Onken, 1996, 23, US EPA, 2003]

Biocides and plant health products are substances or mixtures of substances intended for preventing, destroying, repelling, or mitigating any pest. A more common term for these products is “pesticides”, which is taken to include herbicides and other groups as detailed below.

Pests are living organisms that occur where they are not wanted or where they cause damage to crops or humans or other animals. Table 1.5 gives an overview of the types of biocides and plant health products according to the type of pest they control, and Figure 1.10 gives some examples of biocides and plant health products derived by chemical synthesis.



Pesticide group	Pest group	
Insecticides	Pest insects	[23, US EPA, 2003]
Herbicides	Weeds	
Fungicides	Fungi	
Acaricides	Mites	
Nematocides	Plant-parasitic nematodes	
Molluscicides	Gastropods (snails)	
Rodenticides	Rodent (e.g. mice)	
Microbiocides	Bacteria, viruses	

Table 1.5: Pesticide groups according to the type of pest they control

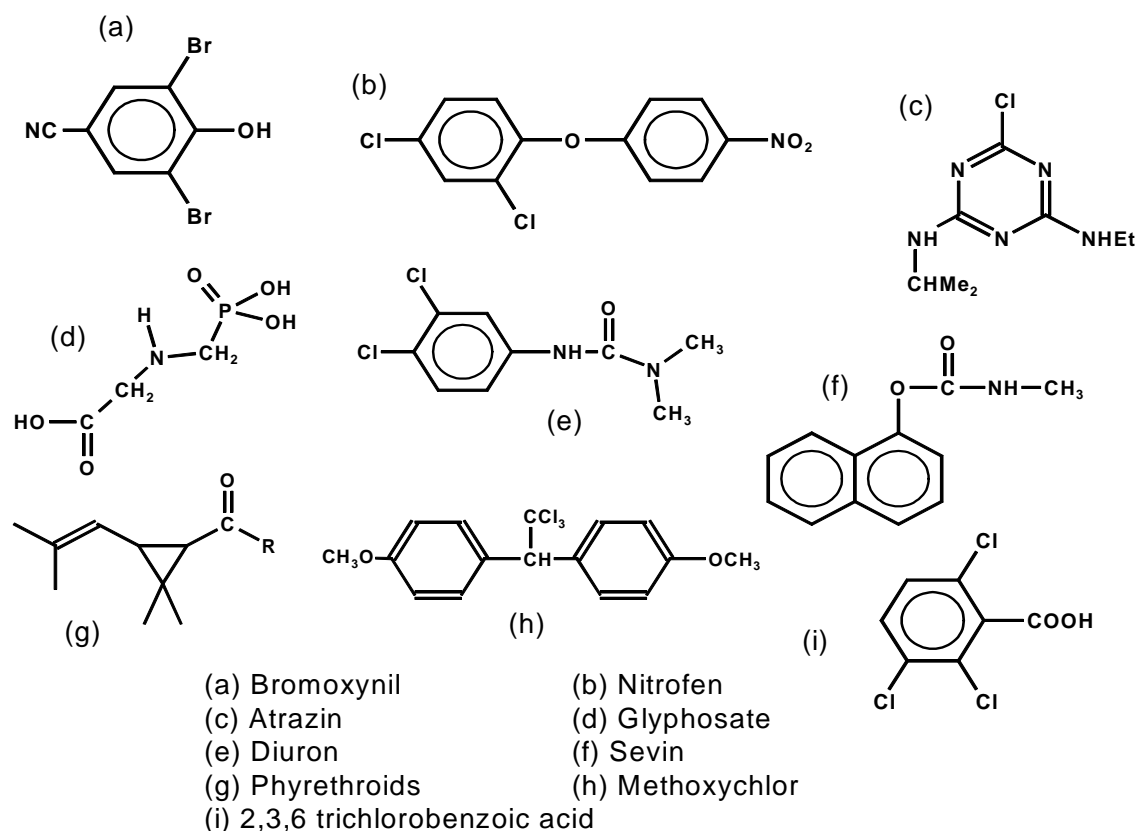

Figure 1.10: Examples of biocides and plant health products

### 1.3.4.2 Process modifications in manufacturing crop protection agents

[56, Jungblut, 2004]

Depending on the country requirements, usually the manufacturing route, description of the starting materials and a specification have to be explained. A modification, which may result in a change to the technical specification, can require some additional studies. For example, changes in the purity of an active ingredient may modify its toxicological or ecotoxicological profile or its ability to be formulated into a plant protection product. The crop protection manufacturing process is subject to specific regulations for any changes to the once approved process via the submission of a "5-batch analysis". This has to show that the proposed change does not affect the minimum purity of the active ingredient or the maximum levels of any other impurities or lead to the presence of any new impurities.

### 1.3.4.3 Economics of crop protection

[22, ECPA, 2002, 32, CEFIC, 2003], [56, Jungblut, 2004]

Not all biocides and plant health products are used for crop protection but only the following information has been submitted.

Over the past ten years, the European crop protection market has been affected by highly volatile economic and political conditions. Despite the pressure that the agricultural sector has been subjected to, the market for crop protection products in the EU continues to be the second largest in the world after North America. Figure 1.12 and Figure 1.13 give an overview of the market composition and development in Europe.

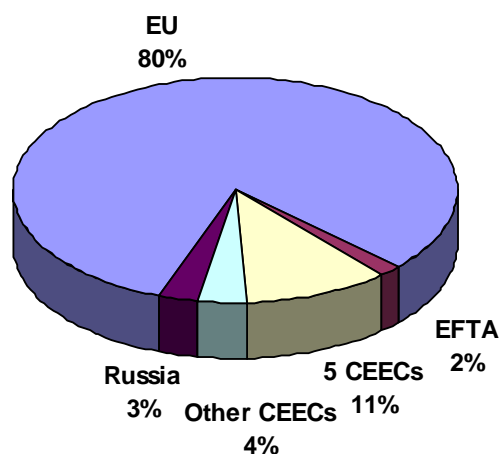

Figure 1.11: European crop protection market in 2001 showing percentages

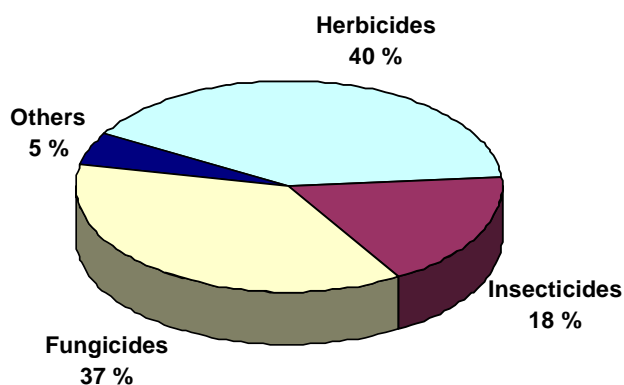

Figure 1.12: Western European market (EU and EFTA) by product sector, 2001

Over the past ten years, the relatively poor performance of the global market (see Figure 1.13) has resulted in considerable consolidation, with a number of companies leaving the market. From a European perspective, the most significant moves have been the merger of Zeneca and Novartis to form Syngenta, the acquisition of Cyanamid by BASF, and the purchase of Aventis by Bayer (so bringing the former operations of Rhone-Poulenc, Hoechst, Schering, Boots and Fisons into one company). Six companies now dominate the global market, with three of these (Syngenta, BASF and Bayer) based in Europe. The other three US companies (Monsanto, Dow and Dupont) all have significant subsidiaries in the EU.

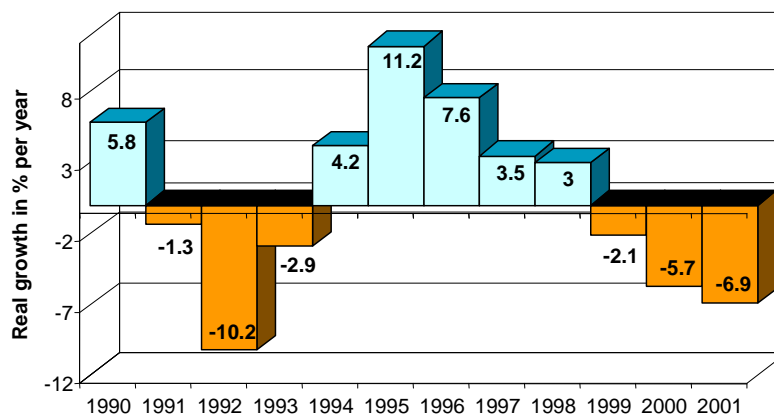

Figure 1.13: Real growth in the Western European crop protection market, 1990 – 2001

### 1.3.5 Fragrances and flavours

[6, Ullmann, 2001]

Fragrance and flavour substances are comparatively strong smelling organic compounds with characteristic, usually pleasant odours. They are used in perfumes and perfumed products, as well as for the flavouring of foods and beverages. Whether a particular product is called a fragrance or a flavour substance depends on its use. Natural products are obtained directly from plant or animal sources by physical procedures. Nature identical compounds are produced synthetically, but are chemically identical to their natural counterparts. Artificial flavour substances are compounds that have not yet been identified in plant or animal products for human consumption. Nature identical aroma substances are, with very few exceptions, the only synthetic compounds used in flavours besides natural products. Figure 1.14 gives some examples.

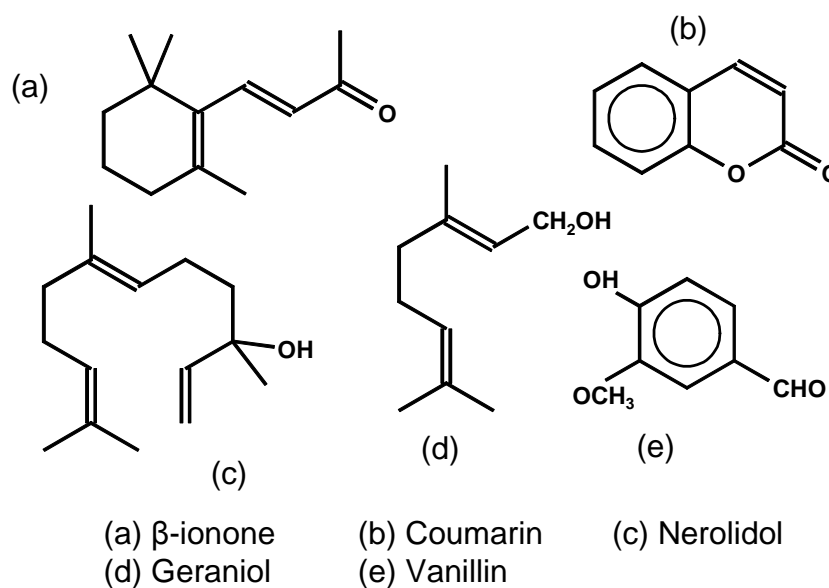

Figure 1.14: Examples of some fragrance and flavour substances

### 1.3.6 Optical brighteners

[2, Onken, 1996, 6, Ullmann, 2001]

Optical brighteners or, more accurately, fluorescent whitening agents, are colourless to weakly coloured organic compounds that, in solution or applied to a substrate, absorb ultraviolet light (e.g. from daylight at c. 300 – 430 nm) and re-emit most of the absorbed energy as blue fluorescent light between c. 400 and 500 nm. In daylight, optical brighteners can thus compensate for the aesthetically undesirable yellowish cast found in white industrial substrates, such as textiles, papers, or plastics. Figure 1.15 gives some examples.

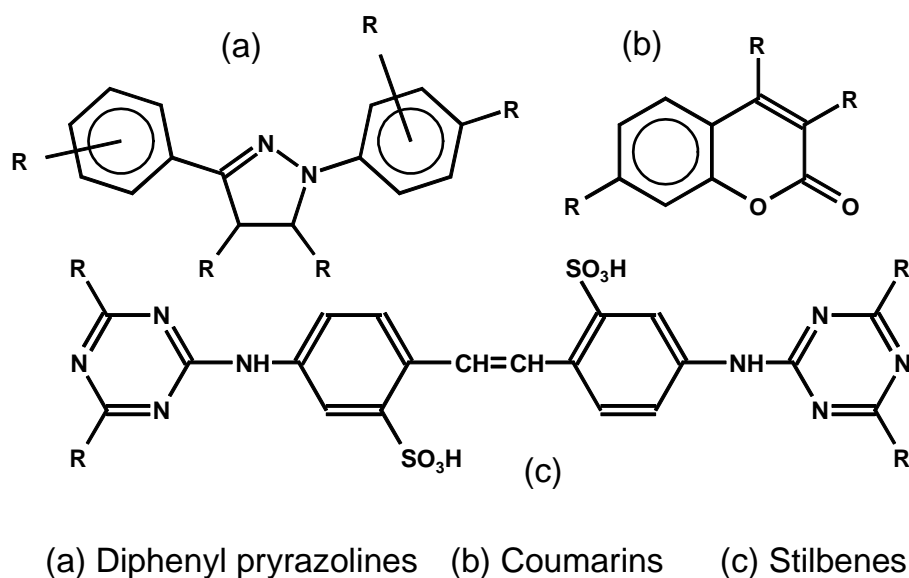

Figure 1.15: Examples of some optical brighteners

### 1.3.7 Flame-retardants

[6, Ullmann, 2001, 24, EFRA, 2003]

Flame retarded materials are modified or treated to be more resistant to ignition than non-flame retarded materials, or to have slower rates of flame spread in a major fire that is initiated by some other source; however, the flame retarded article will still ultimately burn.

Organic flame-retardants are often brominated compounds. The HBr from their decomposition is very effective in deactivating free radicals in the vapour phase. The formation of new radicals is also reduced as less heat is generated, and the entire combustion process is slowed.

Chlorinated compounds function in the same manner. In practice, often twice as much compound containing chlorine is required as compound containing bromine. The difference approaches the atomic mass ratio for the two halogens, i.e.  $79.90 : 35.45 = 2.25$ . Figure 1.16 gives some examples.

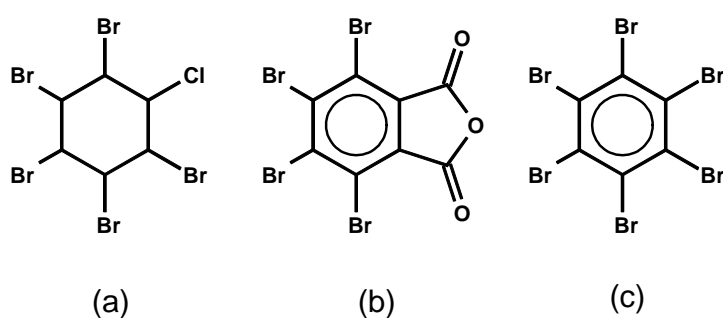

- (a) Pentabromo chloro cyclohexane  
 (b) Tetrabromo phthalic anhydride  
 (c) Hexabromo benzene

**Figure 1.16: Examples of some flame-retardants**

In 2001, the market value of brominated flame-retardant compounds was EUR 864 million (USD 774 million), related to a worldwide consumption of 774000 tonnes. Figure 1.17 and Figure 1.18 show the world market share and the market composition, respectively.

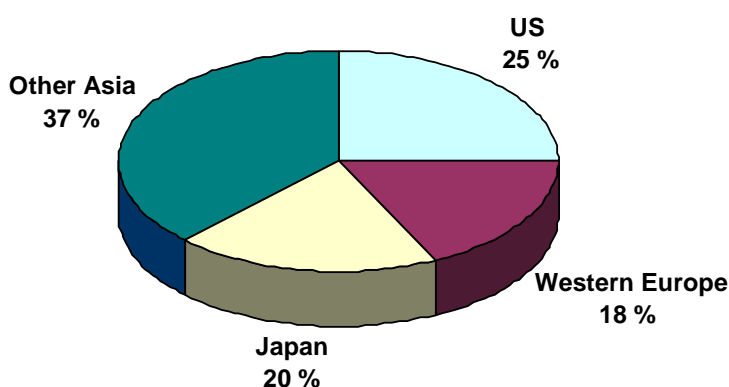

**Figure 1.17: World market for brominated flame-retardant compounds by region**

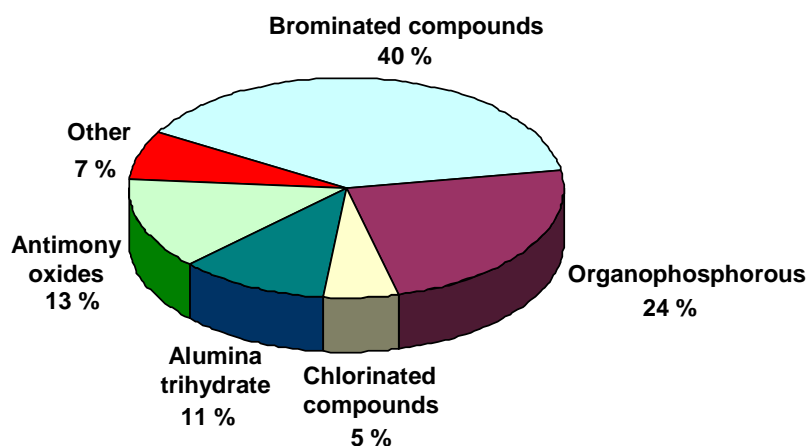

Figure 1.18: Market composition by flame-retardant material

### 1.3.8 Plasticisers

[6, Ullmann, 2001]

A plasticiser is a substance incorporated into a material to increase its flexibility, workability, or distensibility. A plasticiser may reduce the melt viscosity, lower the temperature of the second-order transition, or lower the elastic modulus of the product. Plasticisers are inert, organic substances with low vapour pressures, predominantly esters, and react physically with high polymers to form a homogeneous physical unit, whether it be by means of swelling or dissolving or any other. At present some 300 plasticisers are manufactured, of which at least 100 are of commercial importance. Figure 1.19 shows some of the most widely used plasticisers.

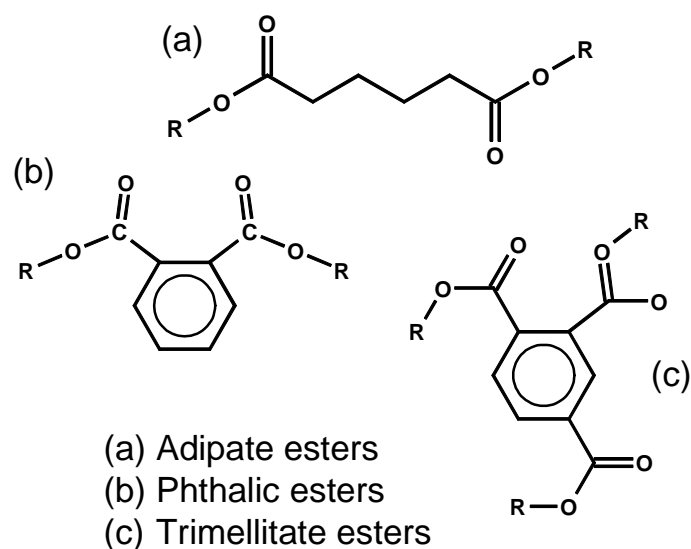

Figure 1.19: Examples of some plasticisers

In 1996, production of plasticisers in Western Europe amounted to  $1253 \times 10^3$  tonnes per year and in the United States to  $636 \times 10^3$  tonnes per year [99, D2 comments, 2005]. In terms of plasticiser types, the majority of this tonnage (>85 %) is standard phthalate (esters of phthalic anhydride with C8 – C10 alcohols). The reasons for this are the relatively low price and readily available feedstocks. The remainder of the market is taken up by phthalate esters of other alcohols, speciality phthalates, adipates, trimellitates, and other esters.

### 1.3.9 Explosives

[46, Ministerio de Medio Ambiente, 2003]

Organic chemical explosives are classified as “secondary explosives” [6, Ullmann, 2001] and represent active ingredients extensively used in energetic products such as dynamites and smokeless powders. Figure 1.20 gives some examples.

Physical explosives (usually considered only as “blasting agents”) are produced by the mixing of non-explosive materials (or materials not intended to be explosive) e.g. diesel oil, ammonium nitrate, and sodium perchlorate.

Explosives are dangerous goods (class 1 ADR) and consequently, due to safety concerns Member States have established special regulations covering their transport, storage and manufacturing. Nearly every change in manufacturing processes and operations requires authorisation by national security authorities.

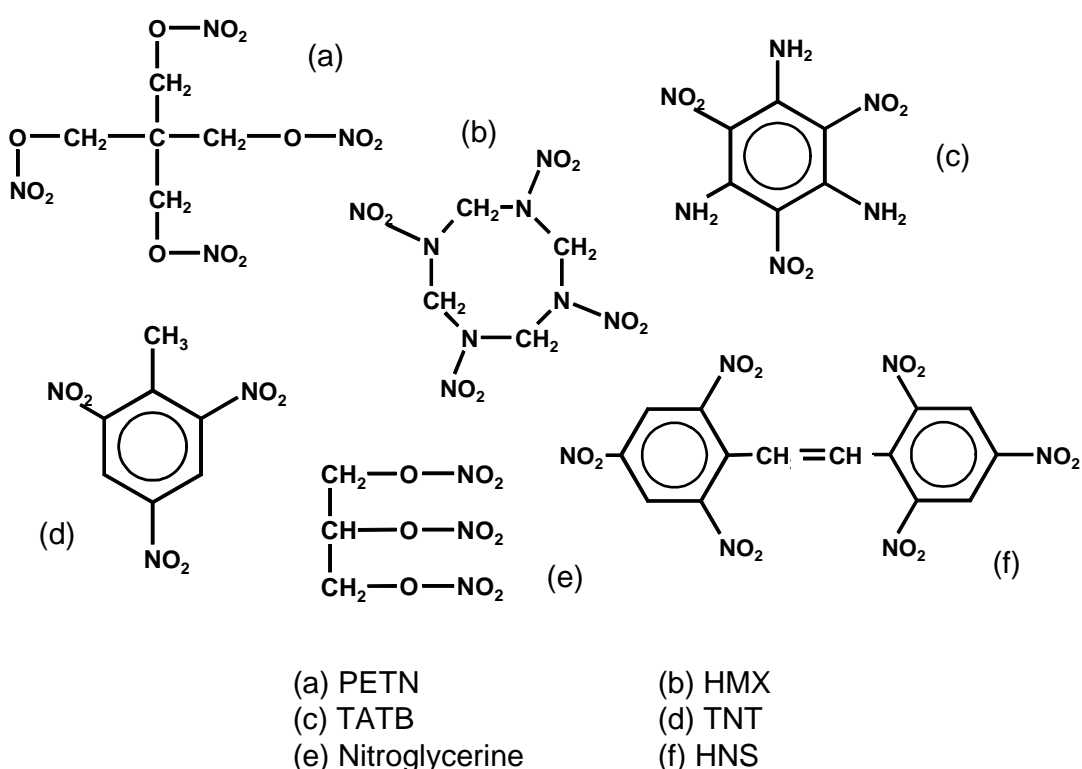

Figure 1.20: Examples of some organic explosives

Secondary explosives are used for industrial and military purposes. Production is carried out by private companies in many countries, e.g. UK, Germany, Norway, Sweden, Switzerland, Portugal. In Spain, production was shared between a national company and private ones until 2004. Nowadays, all Spanish companies are privately operated and owned. In France, military secondary explosives are manufactured by a national company.

Production figures and prices are usually not available, but as an example, the yearly production of civil explosives (both inorganic and organic, including mixtures or blasting agents) in Spain and Portugal amounts to about 95000 tonnes. Only about 9000 tonnes of these are organic explosives produced by chemical methods.





## 2 APPLIED PROCESSES AND TECHNIQUES

This chapter describes a range of processes and techniques applied in the OFC sector, often by giving examples. The selection is based on the information provided and is restricted to examples where the provided information enables the discussion of environmental issues.

### 2.1 Conception: unit processes and operations

[16, Winnacker and Kuechler, 1982], [55, CEFIC, 2003]

The chemistry of fine organic intermediates and products shows an enormous diversity. This results in the problem that at first sight – with regard to environmental issues – no OFC installation seems to be comparable to another. But in reality the number of processes and operations used remains reasonably small and only a limited number of environmental issues have to be discussed.

The primary chemicals used for the manufacture of products such as dyes, pharmaceuticals or biocides are called intermediates and are prepared on an industrial scale from basic organic (usually aromatic) raw materials by various chemical procedures (unit processes). The choice of physical procedures which are applied is limited in a similar way (unit operations). The main unit processes and operations are listed in Table 2.1, which, however, is not conclusive. Often, the route taken to go from the basic organic raw material to the target product is via several unit processes (see Figure 2.1) and possibly includes several unit operations.

Unit processes	Unit operations
Acylation	Charging reactants and solvents
Addition	Inerting
Alkylation	Reaction
Carboxylation	Discharging
Carboxymethylation	Crystallisation
Condensation	Filtration
Diazotisation and modification of the diazo group	Product washing
Esterification	Drying
Halogenation	Extraction
Nitration	Electro dialysis
Oxidation	Absorption
Rearrangements	Phase separation
Reduction	Adsorption
Substitution	Distillation
Sulphitation	Milling
Sulphonation	Apparatus cleaning

**Table 2.1: Main unit processes and unit operations used in industrial fine organic chemistry**

### 2.1.1 Intermediates

[6, Ullmann, 2001, 16, Winnacker and Kuechler, 1982, 19, Booth, 1988]

The number of intermediates actually or potentially available is very large and the technology of their manufacture is an important part of industrial organic chemistry.

Starting raw materials are aromatic hydrocarbons, such as benzene, toluene, naphthalene, anthracene, pyrene, phenol, pyridine and carbazol, as well as a wide range of aliphatic compounds like, e.g. alcohols, carbonic acids, heterocyclic compounds.

Aromatic hydrocarbons undergo four electrophilic substitution reactions – the Friedel-Crafts reaction, halogenation, nitration and sulphonation – as well as oxidation and reduction. The reactions lead to substituted hydrocarbons (primary intermediates).

Most manufacturing processes for primary intermediates are run continuously and with dedicated equipment, because of the large production volume. Subsequent modification steps are usually carried out in batches. Table 2.2 gives some examples. “One pot” synthesis indicates that several reaction steps are carried out without work-up of the intermediates.

	Compound	Unit process	Mode of operation	Use
<b>Primary intermediate</b>	Nitrobenzene	Nitration	Continuous	
	Chlorobenzene	Chlorination	Continuous	
	p-toluene sulphonic acid	Sulphonation	Continuous	
	o-nitroaniline	Exchange	Continuous	
<b>Intermediates</b>	4-chloro-3-nitrobenzene sulphonic acid	Sulphonation	Batch	Dyes
	2,3,4-trichloro-6-nitrophenol	Exchange	Batch, semi-batch	Pesticides
	Bromamine acid	Sulphonation Amination Sulphonation Bromination	Batch, “one pot”	Dyes
	Pyrazolone	Diazotisation Condensation	Batch, “one pot”	Pharmaceuticals Dyes

**Table 2.2: Examples for primary intermediates and intermediates**

## 2.1.2 Isomers and by-products

The stepwise introduction of substituents and their subsequent modification (see Figure 2.1), in combination with the unavoidable drastic reaction conditions (e.g. reactivity of halogens, oxidative effects of concentrated sulphuric/nitric acids, higher reaction temperatures for deactivated aromatics), can lead to an increasing number of side reactions and unwanted by-products, e.g.:

- position isomers
- higher and lower substituted compounds
- modification of substituents
- oxidation products
- by-products derived from the by-products if work-up is omitted (“one pot synthesis”).

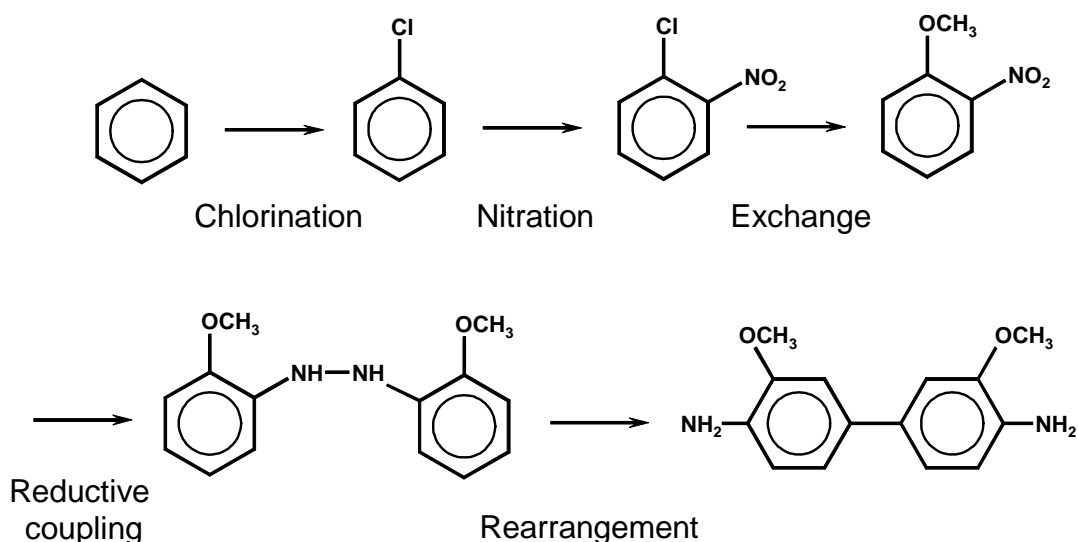

**Figure 2.1:** Illustrative example of a synthesis using several unit processes

Often recovery and re-use of isomers or by-products is technically possible (e.g. as starting material in other plants or sectors). But in many cases a recovery appears difficult due to economical, ecological or legal requirements. If a recovery is not possible, unwanted isomers/by-products have to be separated from the product and contribute to waste or waste water streams.

The nitration of toluene given in Table 2.3 can be used as an illustrative example. In this case, the isomers are separated and purified by distillation.

Starting material	Process	Isomers	By-products
Toluene	Nitration with HNO <sub>3</sub>	o-Nitrotoluene (59.5 %) m-Nitrotoluene (4 %) p-Nitrotoluene (36 %)	Nitrophenols Nitrocresols Nitrohydroxy benzoic acids Phenylnitromethane Tetranitromethane

**Table 2.3:** Example for the formation of isomers and by-products

## 2.2 Multipurpose plants

Multipurpose plants enable the operator to manufacture different products with a certain flexibility according to market requirements. Figure 2.2 gives an impression of the arrangement in a typical plant, which uses gravity flow for efficient material transport. The main components in the multipurpose plant are:

- raw material storage (warehouse, tank farm)
- reactors and vessels
- finished and intermediate storage
- utilities (e.g. cooling, vacuum, steam, cleaning)
- process control systems
- feed tanks (usually upper floors)
- purification and separation equipment
- recovery and abatement facilities
- blow-off systems and catch tanks.

Production campaigns with batch wise, semi-batch or continuous operation of reactors and facilities for product work-up alternate with shutdown, cleaning and start-up situations.

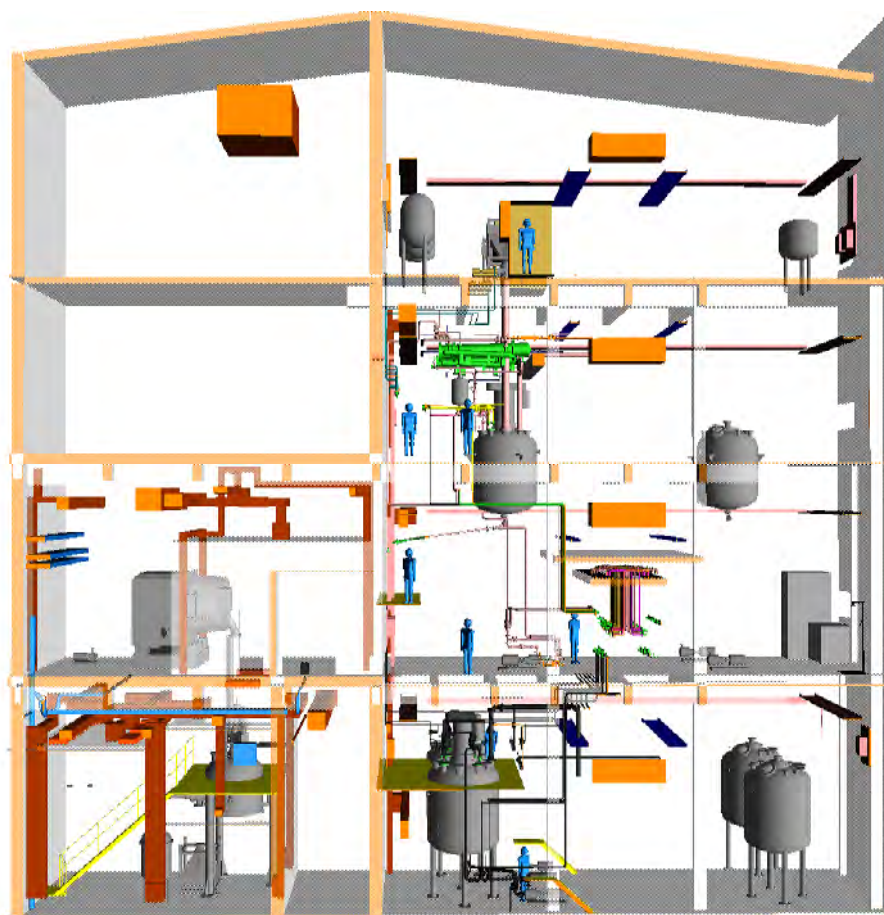

Figure 2.2: Typical layout for a multipurpose plant

The example schedule given in Figure 2.3 shows the utilisation of 17 vessels in a production building on a multipurpose plant with 22 different products/intermediates (shown as different colours). This picture could vary drastically over the year due to a possibly changed market situation. The use of the capacity varies from 60 to 95 %. Lower values would be critical from an economic point of view. Higher values would represent a real challenge from an operational point of view.

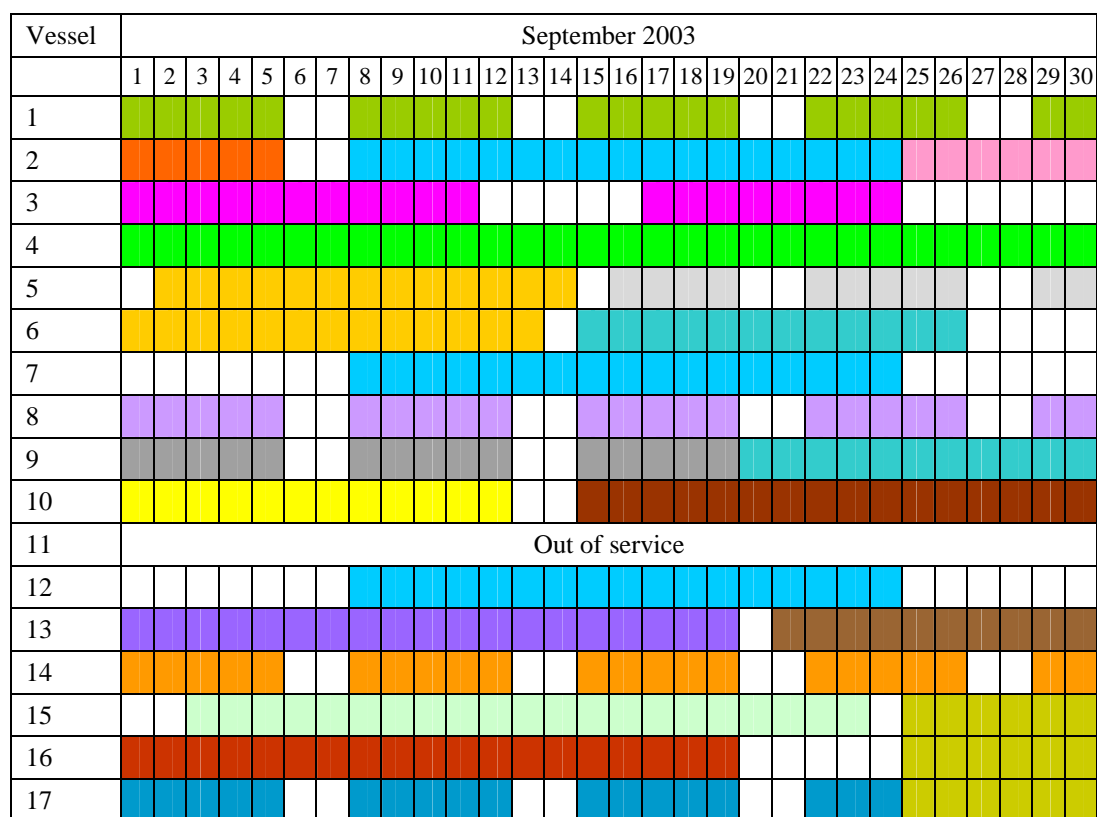

Figure 2.3: Example for the utilisation of the vessels in a production building

## 2.3 Equipment and unit operations

### 2.3.1 Reactors

[6, Ullmann, 2001]

The main equipment in multipurpose plants is the **stirred tank reactor**, which fulfils the flexibility requirements arising from the varied physical states of the materials being used (e.g. dry powders, wet solids, pastes, liquids, emulsions, gases).

The vessels are required to withstand a range of process conditions (e. g. temperature, pressure, corrosion) and are thus usually made of stainless steel, rubber- or glass-lined steel, enamel coated, or other special materials. The mechanical design of the agitator baffles and cooling systems is constrained by the need to attach and maintain the rubber or glass lining.

Other characteristics:

- used for both batch and continuous mode, as well as in cascades
- sized up to 60 m<sup>3</sup> (fermentation reactors up to about 1000 m<sup>3</sup>)
- usually dished bottom (reactions may be carried out under pressure)
- equipped with one or more stirrers to ensure the requested mixing degree, heat-exchange performance, etc.
- jackets or half pipe coils are often fitted around the vessel to provide heat transfer
- wall baffles are installed inside to prevent the gross rotation (“swirl”) of the contents with the stirrer.

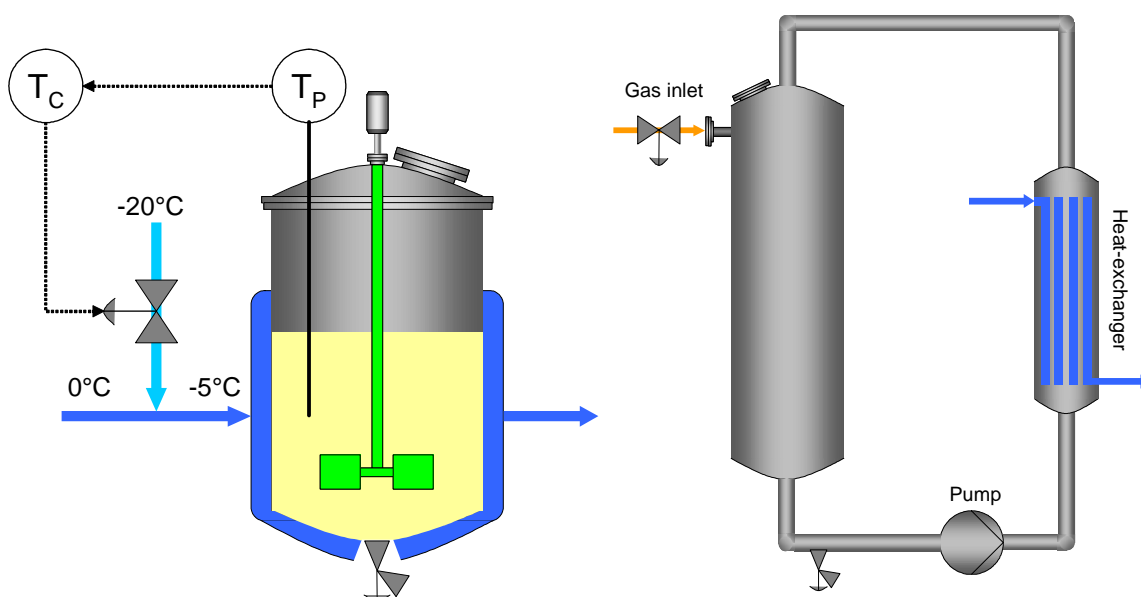

Figure 2.4: Stirred tank reactor (conventional temperature control, left) and loop reactor (right)

Other used reactor types are, e.g:

- loop reactors (closed loop or continuous loop)
- bubble columns (closed loop or continuous loop)
- pipe reactors
- tubular reactors.

### 2.3.1.1 Liquid addition to reactors

[18, CEFIC, 2003]

Liquids are added to reaction vessels for a number of reasons, e.g.

- raw material charge as part of a recipe for a batch reaction
- raw material for a semi-batch reaction (i.e. reacts as it is charged)
- adjustment of reactant concentrations
- refluxing to control the reaction temperature
- quenching to stop a reaction
- cleaning.

Many factors, such as material properties, operational mode, reactor temperature and pressure, reactor contents as well as related management/procedures and training are taken into account for designing or reviewing this operation.

The common methods of charging include:

- pumping from storage tanks, process vessels, road cars, IBCs, drums
- gravity flow
- pressurised gas transfer (compressed air, nitrogen, etc.)
- vacuum transfer
- manual charging [99, D2 comments, 2005].

For information on material transfer with pigging systems see Section 4.2.8.

Vessels must be protected from over/under pressure by construction design, safety relief systems and/or appropriate control systems.

The **environmental issue** is the displacement of gas/vapours from the reactor into a vent system during filling (if gas balancing is not possible). The vent system discharges via a recovery/abatement system if treatment is required or directly to the air.

### 2.3.2 Equipment and operations for product work-up

[18, CEFIC, 2003, 46, Ministerio de Medio Ambiente, 2003]

#### 2.3.2.1 Drying

Many different dryer types are available and are in use. They include among others: fluidised bed dryers, vacuum dryers, spray dryers, band/belt dryers.

Common **environmental issues** are the:

- removal of gases or vapour of the solvent together with
- finer solid material.

Therefore, dryers are usually connected to a dust collection system (cyclones, filters, scrubbers) and/or VOC recovery/abatement systems (scrubbers, adsorption, condensers).

### 2.3.2.2 Liquid-solid separation

Liquid-solid separation is used, e.g. for the separation of a precipitated product, catalyst, solid impurities. The spectrum of the available and used equipment is wide and includes decanters, decanter centrifuges, sieves, sand filters, rotary drum filters, band filters, plate filters, Nutsche filters, membrane systems, centrifuges.

The **environmental issues** are linked to the properties of the liquid. The main aspects are:

- VOCs from vents
- organic or aqueous mother liquors or washes.

These are usually treated by applying recovery or abatement techniques.

### 2.3.2.3 Distillation

Distillation is carried out to separate or purify volatile components from less volatile components. A distillation unit always consists of a means of heating the feed, the column or the vapour line (with many alternatives of packing to achieve specific results) and a heat-exchanger to condense the vapours.

The main environmental issues are:

- energy efficiency (efficient design, insulation, heating, cooling)
- emissions to air from the condenser vent in case of atmospheric distillations
- waste streams (which can be re-used or recovered, or disposed of)
- wastes from cleaning.

### 2.3.2.4 Liquid-liquid extraction

Liquid-liquid extraction or solvent extraction is a separation process which is based on the different distribution of the components to be separated between two liquid phases.

Liquid-liquid extraction is primarily applied where direct separation methods such as distillation and crystallisation cannot be used or are too costly. Liquid-liquid extraction is also used when the components to be separated are heat sensitive (e.g. antibiotics) or relatively non-volatile.

Extraction apparatus can be classified into countercurrent columns, centrifugal extractors, and mixer-settlers. In a simple case, even a stirred tank may be applicable. All industrial equipment designs use the principle of dispersing one of the two liquids into the other in order to enlarge the contact area for mass transfer.

The main **environmental issues** are linked to the properties of the liquids:

- VOCs from vents
- organic or aqueous mother liquors.

These are usually treated by applying recovery or abatement techniques.



### 2.3.3 Cooling

[57, UBA, 2004]

Cooling can be carried out directly or indirectly (Table 2.4). For information on indirect cooling see also Section 4.2.9. Direct cooling is also used as a reaction stopper in emergency situations.

	Operation	Description	Environmental issue
Direct	Water injection	Direct cooling is carried out by injection of water, usually to cool down vapour phases	Waste water streams loaded with vapour contaminants
	Addition of ice or water	Addition of ice or water is carried out to adjust temperature of processes (e.g. to enable temperature jumps or shocks)	Increased volume of waste water streams
Indirect	Surface heat-exchange	Indirect cooling is provided by surface heat-exchangers, where the cooling medium (e.g. water, brines) is pumped in a separate circuit	Cooling waters and spent brines

**Table 2.4: Direct and indirect cooling**

### 2.3.4 Cleaning

[46, Ministerio de Medio Ambiente, 2003]

Due to the frequent product changes, well established cleaning procedures are required to avoid cross-contamination, e.g. for the production of intermediates and APIs.

The cleaning of equipment, such as reactors, centrifuges and sieves is carried out using water, sodium hydroxide, hydrochloric acid, acetone, specific solvents and steam, depending on the equipment or substances to be cleaned. The cleaning process is finished with water to rinse or with an organic solvent (water free rinsing) where the drying of the equipment is important.

The cleaning process can be carried out in different ways:

**With hoses:** Cleaning is carried out with pressurised water from a hose to reduce water consumption.

**Cleaning-in-place units (CIP):** Different systems of cleaning have been established to limit emissions and to improve efficiency, such as the CIP system. Cleaning-in-place allows equipment to be cleaned directly inside with water scatterers under pressure and allows cleaning liquids to be recovered (where the operator is not concerned about cross-contamination). CIP also enables the operator to carry out the cleaning process without the need to take the equipment apart or for workers to enter the vessels.

The main **environmental issues** are:

- waste water streams loaded with residual substances from processes or cleaning
- VOC releases to air from the use of solvents
- and solvents containing residual substances from processes or cleaning.

### 2.3.5 Energy supply

[43, Chimia, 2000]

Two main sources of energy are consumed on the typical site:

- steam
- electricity.

Generally, only steam is produced on-site and electricity is supplied by an external source. Cogeneration by self-production of electricity and steam is advantageous on large sites.

Energy is normally provided by boilers equipped with turbines fitted with burners for natural gas and fuel oil, with gas being the main fuel (about 95 %). Spent solvents are often used as a fuel together with gas.

Figure 2.5 shows an example for a setup with two boilers sharing an exhaust gas recuperator. Here the smaller boiler (boiler 1 which produces 80 tonnes steam/hour) is mainly used in summer and the larger boiler (boiler 2 which produces 160 tonnes steam/hour) mainly in winter, when the steam demand is higher. The recuperator cools down the exhaust gas from 130 °C to about 45 °C and warms the water from 20 °C to about 60 °C. About 3.8 MW heat is recovered.

Steam and electricity can also be provided by on-site combined cycle power plants, thermal oxidisers or incinerators.

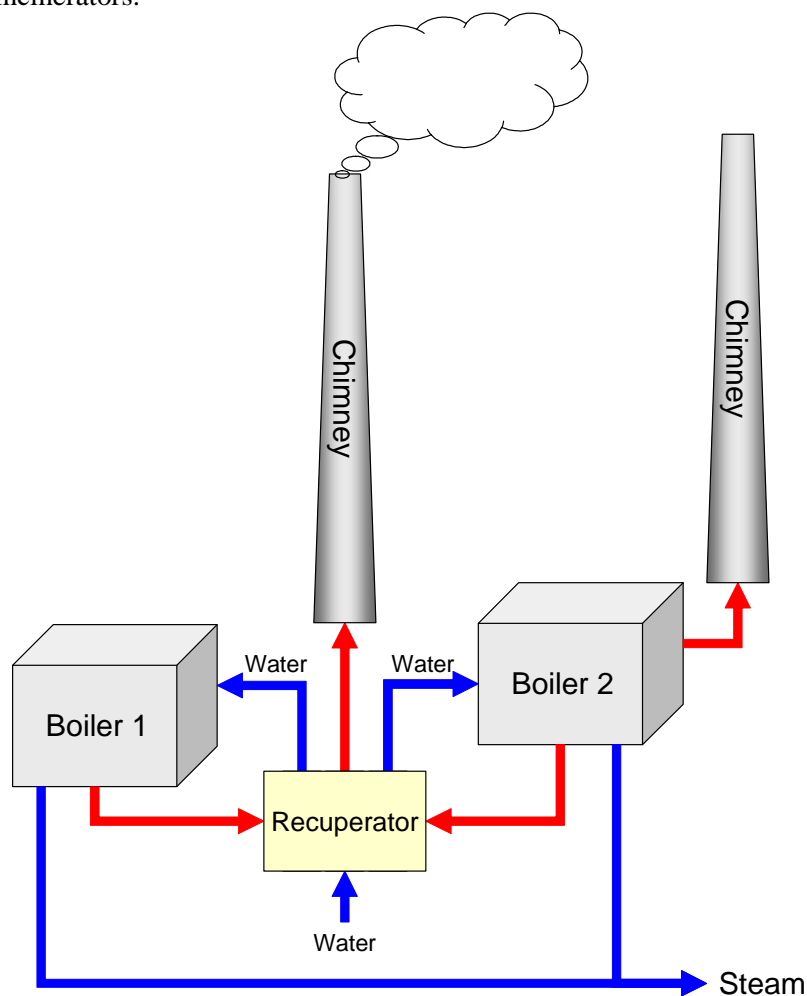

Figure 2.5: Example of an energy supply setup with two boilers

### 2.3.6 Vacuum systems

[9, Christ, 1999]

Many processes in organic chemistry are operated under vacuum. A number of criteria influence the selection of a vacuum pump, such as the required pressure difference, volume flows, temperature, etc. The choice of the pump type is relevant also from the environmental point of view. Table 2.5 gives an overview to some pump types and the environmental issues.

Pump type	Medium	Main environmental issues
Liquid ring vacuum pump	Water	Water ring pumps cause relatively large amounts of waste waters streams. If VOCs are present, these contaminate the waste water stream. Especially halogenated hydrocarbons can be a problem
	Solvent	Contamination with the pumped substance, typically connected to a recovery system
Dry vacuum pump	No medium, no lubrication	No contamination of any medium
Dry vacuum pump	No medium, with lubrication	The lubrication oil has to be collected and disposed of

**Table 2.5: Some pump types and their main environmental issues**

For information on vacuum generation see also Sections 4.2.5 and 4.2.6.

### 2.3.7 Recovery/abatement of exhaust gases

[15, Köpke, 2000]; [31, European Commission, 2003], \*019A,I\*

Figure 2.6 gives an overview of the recovery/abatement techniques applied to exhaust gases. Oxidisers include thermal and catalytic oxidation. The choice of a particular technique or a particular combination of techniques depends on the contaminants present and especially on the VOC concentration, flow and the variations in concentration and flow. Additionally, various types of filters can be used to recover particulates.

Events of planned or emergency shutdowns may require back-up systems or modifications of schedules and hours of operation.

Primary and secondary condensers (non-cryogenic) are directly attached to the reactors. If VOC rich exhaust gases are treated by thermal oxidation, other streams can be used as the oxygen source, e.g. VOC lean or odorous streams.

#### Thermal oxidisers and incinerators

In this document, the term “thermal oxidation” is used where applied to the gas phase, however, where co-treatment of gas, liquids and/or solids is carried out, then “incineration” is used.

The **gas collection system** consists of the source enclosure, vents and pipes. The gas flowrate is minimised by encasing the source as far as feasible. **Explosion risks** are controlled by the installation of flammability detectors inside the collection system and by keeping the gas mixture securely below the lower explosion limit (“LEL”, usually below 25 % LEL), above the higher explosion limit or by inertisation.

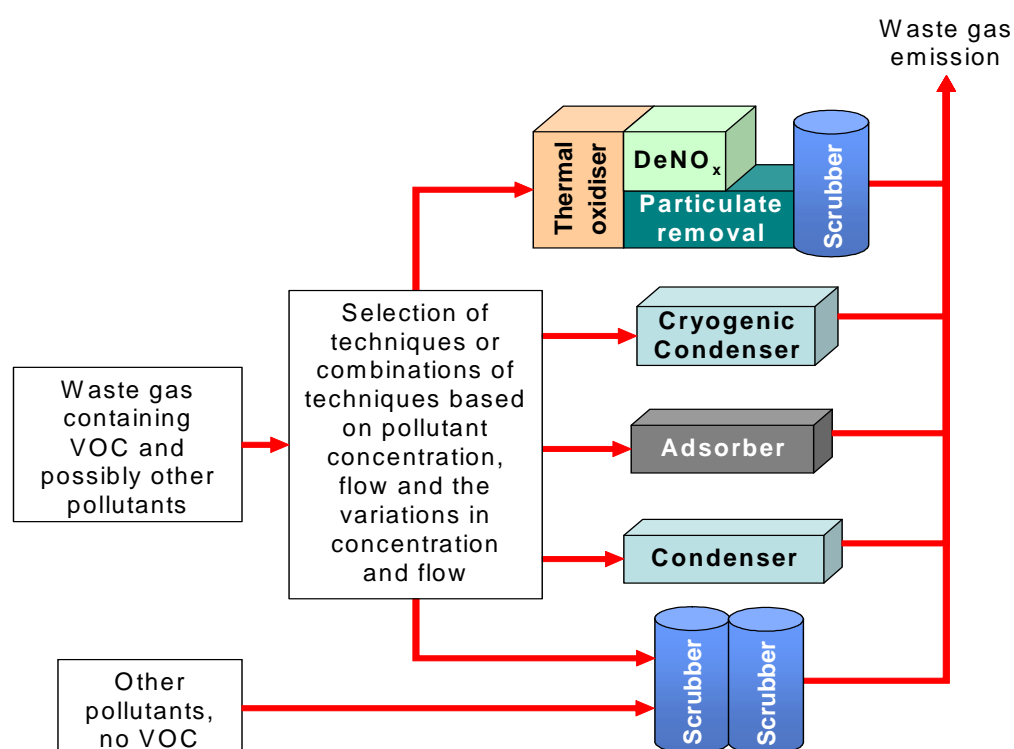

Figure 2.6: Typically applied recovery/abatement techniques for exhaust gases on OFC sites

### 2.3.8 Recovery/abatement applied to waste water streams

Figure 2.7 gives an overview of the applied recovery/abatement techniques applied to waste water streams. The total effluent is normally treated in a biological WWTP, on-site or together with other waste water in off-site plants (in most cases municipal).

Particular waste water streams which are not suitable for biological treatment are segregated and separately pretreated or disposed of as waste (e.g. incineration).

In order to ensure a uniform input level for the biological WWTP as much as possible, a sufficient buffer volume is provided. Providing equalisation can often efficiently reduce toxicity to a level where it will not adversely impact the operations of a biological WWTP.

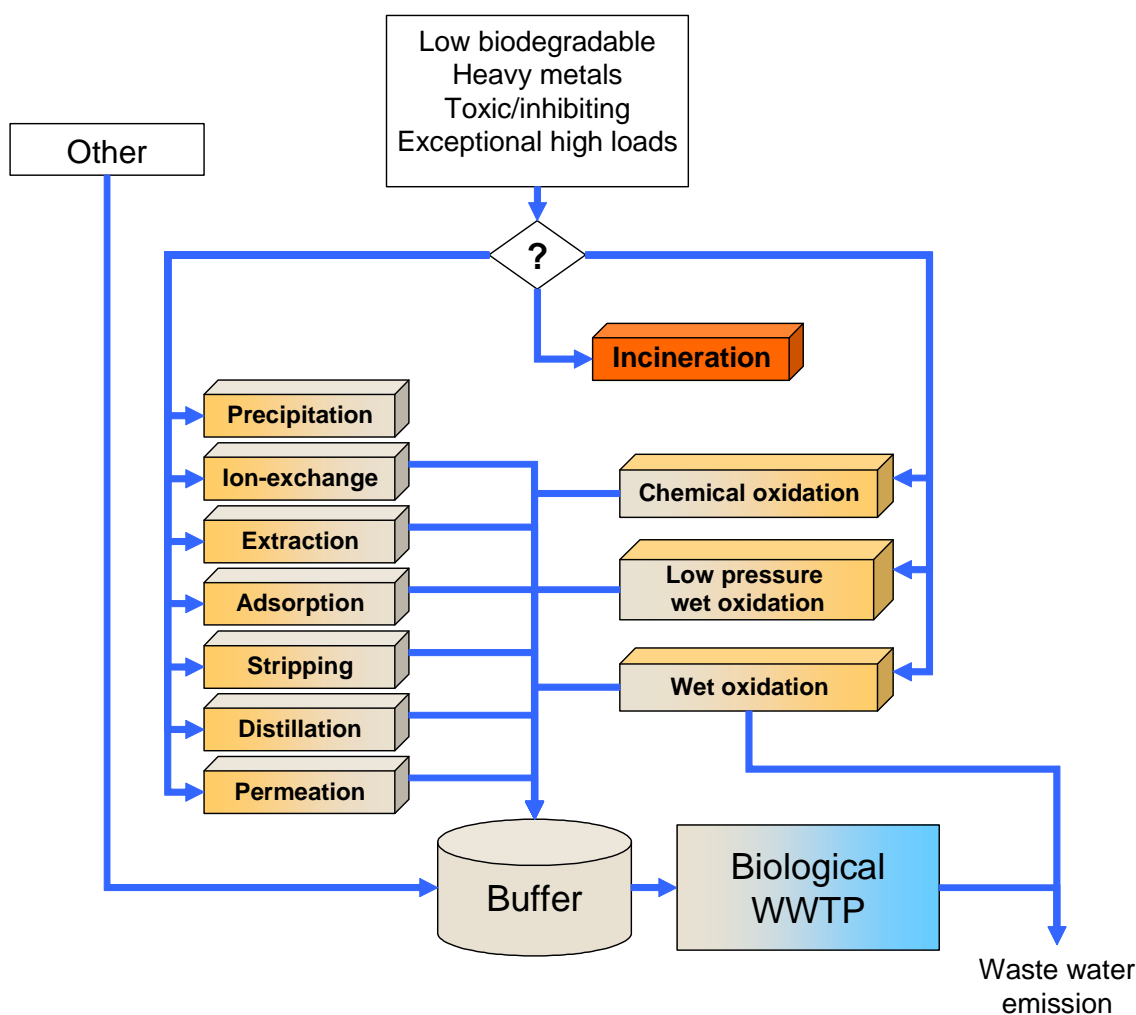

Figure 2.7: Typically applied recovery/abatement techniques for waste water streams on OFC sites

### 2.3.9 Groundwater protection and fire fighting water

[46, Ministerio de Medio Ambiente, 2003], \*019A,I\*

The aim is to avoid the disruption of production operations and to avoid the discharge of substances hazardous to water. The strategy for groundwater protection is based on three major aspects:

- (1) stable and leak-proof facilities
- (2) adequate retention volumes for spillages and fire-fighting water
- (3) adequate monitoring and control equipment including alarms as well as qualified personnel.

Typical measures for catching spills, wash-waters from cleaning, or possibly contaminated rainwater from production or materials transfer areas are:

- concrete or asphalt base with sealed liners or impermeable paints
- bunded areas or basements for production areas
- monitoring of storm-water for organic content, pH and conductivity before discharge
- retention ponds for fire fighting water and contaminated storm-water.

### 2.3.10 Solvent recovery

\*019A,I\*

Solvent recovery is carried out on-site or off-site. Figure 2.8 shows the typically applied processing units.

Factors that influence whether a solvent is recovered are:

- purity requirements for internal re-use in the process (e.g. cGMP requirements)
- purity requirements for commercial re-use
- complexity of the purification process to reach the required purity, e.g. if mixtures form azeotropes
- gap between the boiling points in the case of solvent mixtures
- purchase costs for the fresh solvent compared to the work-up costs
- amount of waste streams created
- safety requirements
- other, e.g. process variation procedures under cGMP.

The waste streams can be re-used or recovered, but many need to be considered for a disposal route.

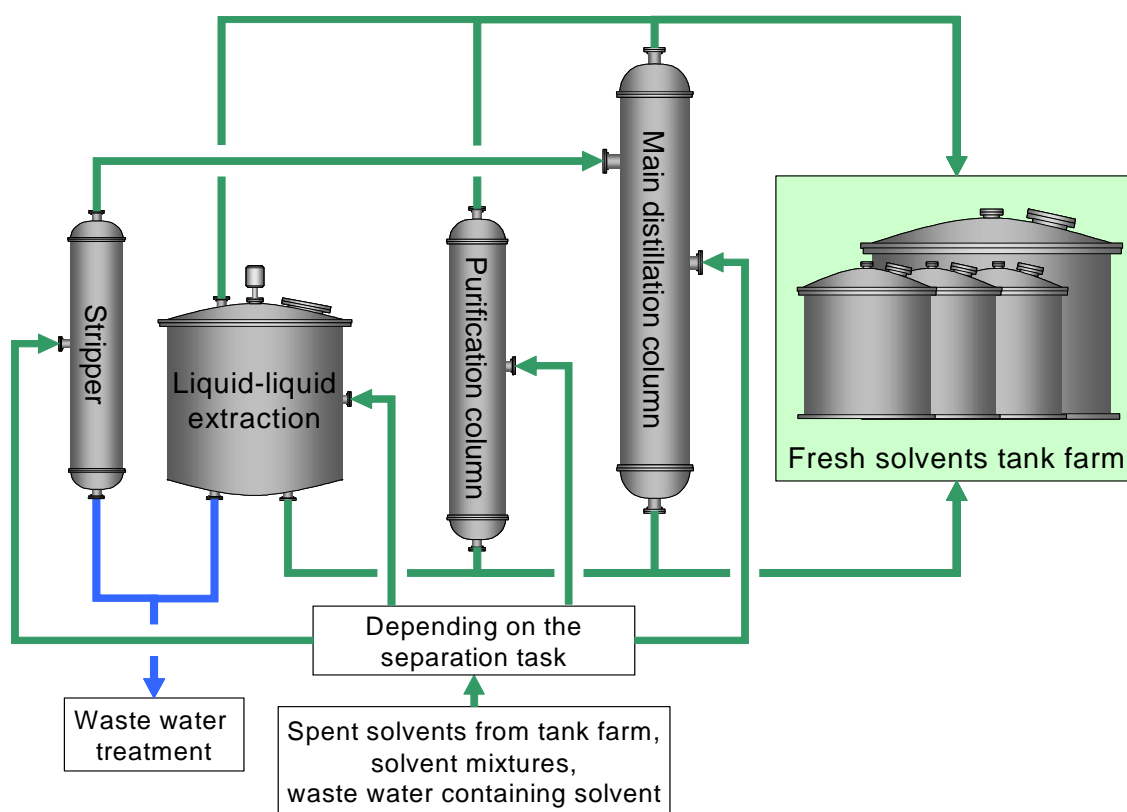

Figure 2.8: Typically applied processing units for solvent recovery on OFC sites

## 2.4 Site management and monitoring

### 2.4.1 Emission inventories and monitoring

[31, European Commission, 2003], \*018A,I\*, \*006A,I\*

#### Emission inventory

Because of the production characteristics (batches, campaigns) the emission inventory is the key for understanding, operating and improving an OFC plant (not only) from an environmental point of view.

A typical OFC site has implemented a system for the identification of generated waste streams and documentation of their further fate: output from processes, recovery, abatement and emissions. The obtained databases are used as tools for improvement strategies, communication with authorities (e.g. applications) and to fulfil report requirements. Table 2.6 gives an overview of the main parts of the management systems.

Instrument		Description
Site inventory	Plans, maps, brief descriptions	Schematic location of facilities, sources for waste streams, collection systems, sampling points
	Production matrix	Records of batches/campaigns
Waste stream inventory	Waste stream analysis	Process related identification and characterisation of each waste stream
	Waste streams from other sources	Identification and characterisation of other waste streams, e.g. from recovery systems
	Emission sources and emission data	Emission data related to the source and compared to the limits where fixed in permits
Mass balances	Solvent/VOC balance	
	Highly hazardous substances	
	Heavy metals	
	COD balance	
Environmental impact assessment	Characterisation of substances at the interface plant/environment	Substances, mass flows, concentrations, characteristics (continuous/discontinuous) environmental impact
	Characterisation of the whole effluent at the interface plant/environment	Toxicity levels

**Table 2.6: Typical instruments for establishing an emission inventory**

#### Monitoring

The emission inventory is mainly based on monitoring data but also partly on calculations and estimations (e.g. diffuse emissions from a biological WWTP). Parameters and monitoring frequencies are usually fixed in permits.



## 2.4.2 Overview to sources and parameters/pollutants

### 2.4.2.1 Waste gas emissions

[31, European Commission, 2003]

The waste gas emissions can be divided into ducted emissions and non-ducted emissions (diffuse or fugitive). Table 2.7 gives an overview of the main sources and pollutants.

<b>Sources</b>	From process equipment	
	Exhaust gases from reaction vessels and condensers	
	Exhaust gases from catalyst regeneration	
	Exhaust gases from solvent regeneration	
	Exhaust gases from storage and handling	
	Exhaust gases from purge vents or preheating equipment	
	Discharges from safety relief devices	
	Exhaust gases from general ventilation systems	
	Exhaust gases from diffuse or fugitive sources installed within an enclosure or building	
<b>Others</b>	Diffuse emissions	
	Fugitive emissions	
<b>Pollutants</b>	Sulphur compounds	SO <sub>2</sub> , SO <sub>3</sub> , H <sub>2</sub> S, CS <sub>2</sub> , COS
	Nitrogen compounds	NO <sub>x</sub> , N <sub>2</sub> O, NH <sub>3</sub> , HCN
	Halogens and compounds	Cl <sub>2</sub> , Br <sub>2</sub> , HF, HCl, HBr
	Incomplete combustion products	CO, C <sub>x</sub> H <sub>y</sub>
	Volatile organic compounds	VOC, halogenated VOC
	Particulate matter	Dust, soot, alkali, heavy metals
	Other	CO <sub>2</sub>

**Table 2.7: Overview to sources and pollutants for waste gas emissions**

## 2.4.2.2 Solvents and volatile organic compounds

[38, Moretti, 2001, 46, Ministerio de Medio Ambiente, 2003]

A volatile organic compound (VOC according to the VOC Directive) is any organic compound having at 293.15 K a vapour pressure of 0.01 kPa or more, or having a corresponding volatility under the particular conditions of use.

VOC emissions arise mainly from the use of solvents, but also from volatile raw materials, intermediates, products and by-products. The relation between the main VOC compound families and their relative share in the emissions to the air from the Organic Fine Chemicals sector is given in Figure 3.1 on page 75 [46, Ministerio de Medio Ambiente, 2003]. Other emitted VOCs include CFCs, ethers, free acids, amines, terpenes, mercaptans, thioethers, nitriles, peroxy nitrates (PAN), nitroalkanes, nitroaromatics and heterocyclics containing N, O or S. Table 2.8 lists some organic solvents used in the OFC sector [60, SICOS, 2003].

Solvent	Formula	Comment
Methanol	CH <sub>4</sub> O	
Toluene	C <sub>7</sub> H <sub>8</sub>	
Acetone	C <sub>3</sub> H <sub>6</sub> O	
Ethanol	C <sub>2</sub> H <sub>6</sub> O	
o-chlorotoluene	C <sub>7</sub> H <sub>7</sub> Cl	halogenated R40
Benzene	C <sub>6</sub> H <sub>6</sub>	R45
Trichloromethane	CHCl <sub>3</sub>	halogenated R40
1,2 dichloroethane	C <sub>2</sub> H <sub>4</sub> Cl <sub>2</sub>	R45
Dichloromethane (methylene chloride)	CH <sub>2</sub> Cl <sub>2</sub>	halogenated R40
Dimethylformamide	C <sub>3</sub> H <sub>7</sub> NO	R61

Table 2.8: Some solvents used in the OFC sector

## The VOC Directive

The *Council Directive 1999/13/EC on the limitations of emissions of volatile organic substances due to the use of organic solvents in certain activities and installations* contains regulations for pharmaceutical companies consuming more than 50 tonnes of solvents per year (Table 2.9).

Activity	ELV in waste gases	Fugitive emission values (of solvent input) <sup>(2)</sup>		Total ELV (of solvent input)	
		New	Existing	New	Existing
Manufacturing of pharmaceutical products	20 <sup>(1)</sup> mg C/m <sup>3</sup>	5 %	15 %	5 %	15 %
<sup>(1)</sup> If techniques are used which allow the re-use of recovered solvents, the ELV is 150 mg C/m <sup>3</sup> <sup>(2)</sup> The fugitive ELV does not include solvents sold as part of products in a sealed container					
Compounds			ELV	Threshold	
VOCs classified as carcinogens, mutagens, or toxic to reproduction under Directive 67/548/EEC		Assigned or need to carry the risk phrases R45, R46, R49, R60, R61		2 mg/m <sup>3</sup>	10 g/hour
Halogenated VOCs		Assigned the risk phrase R40		20 mg/m <sup>3</sup>	100 g/h

Table 2.9: Limit values for the manufacture of pharmaceutical products in the VOC Directive

### 2.4.2.3 Waste water emissions

[31, European Commission, 2003]

Table 2.10 gives an overview of the sources of waste water streams, possible contaminants and the relevant parameters.

Mother liquors and initial wash-waters contribute up to 90 % of the contaminant loads, although their share of the total volume is only about 10 to 30 %. Toxicity/inhibition and bioeliminability are key parameters for functionality and the performance of biological treatment plants.

<b>Main sources</b>	Mother liquors from processing products	
	Wash-water the from purification of products	
	Vapour condensates	
	Quench water	
	Waste water streams from the treatment of exhaust gases or flue-gas treatment (scrubbers)	
	Waste water streams from rinsing and cleaning	
	Contaminated water from vacuum generation	
<b>Other sources</b>	Conditioning of utility water, bleed from boiler feed-water systems, blowdown from cooling cycles, back-washing of filters, laboratory or pilot scale plants, sanitation waste water, rainwater from contaminated surfaces, landfill leachates	
<b>Contaminants</b>	Non-reacted starting material	
	Production residues	
	Auxiliaries	
	Intermediate compounds	
	Unwanted by-products	
<b>Relevant parameters</b>	General	Toxicity
	Organic load	COD/TOC, BOD, bioeliminability, AOX (also EOX), toxicity, persistency, bioaccumulation; for Whole Effluent Assessment (WEA) see Section 4.3.8.19
	Inorganic load	Heavy metals, NH <sub>4</sub> -N, inorganic N
	Individual substances	Solvents, priority substances, POPs
	Other	P-total, N-total, pH, hydraulic load, temperature
	<b>Causes for high loads</b>	
	COD/TOC, BOD, AOX	Organic compounds, soluble in water or miscible with water
	Low bioeliminability	See Section 2.4.2.4
	AOX	Halogenated starting materials, halogenated solvents, halogenation products
	Heavy metals	Heavy metals as reactants, catalysts or incorporated in organic compounds

**Table 2.10: Overview of the sources of waste water streams, contaminants and relevant parameters**

### 2.4.2.4 Biodegradability and elimination of organic compounds

[27, OECD, 2003, 28, Loonen, 1999, 29, Kaltenmeier, 1990]

#### Rules of thumb

Biological degradation or the degree of elimination of a particular compound in a biological WWTP is difficult to predict and theoretical/mathematical methods are still burdened with uncertainties. However, some rules of thumb can be established:

- aliphatic compounds are usually easily degradable
- aliphatic compounds with branched chains or rings with hetero atoms (e.g. cyclic ethers) or with halogen atoms show low biodegradabilities
- simple aromatic compounds are usually easily degradable
- aromatic compounds with functional groups such as  $-\text{SO}_3\text{H}$ ,  $-\text{NO}_2$  or  $-\text{X}$  have low biodegradabilities
- Functional groups such as  $-\text{NO}_2$ ,  $-\text{NH}_2$ ,  $-\text{COOH}$  and especially  $-\text{SO}_3\text{H}$  decrease the degree of elimination (higher water solubility).

Figure 2.9 and Figure 2.10 illustrate these rules for aromatic compounds [30, ESIS, 2003].

#### Degradability testing and interpretation of results

Table 2.11 gives an overview of the most common degradation tests in use.

Readily biodegradability tests are screening tests under aerobic conditions, in which a high concentration of the test substance (2 to 100 mg/l) is used and the biodegradation rate is measured by parameters such as COD, BOD and  $\text{CO}_2$ . A positive result is interpreted as rapid degradation in most environments.

Inherent biodegradability tests are used to assess whether a chemical has any potential for biodegradation under aerobic conditions. The test procedures allow prolonged exposure of the test substance to micro-organisms and a low test substance to biomass ratio, sometimes including an adaptation of the biomass, leading to a significantly more extensive degradation of the chemical. A negative result in tests for inherent biodegradability may lead to a preliminary conclusion of environmental persistency or inhibiting effects.

The test result (see examples given in Figure 2.9 and Figure 2.10 from the ESIS database and e.g. Table 4.27, Table 4.29, Table 4.34 for process waters) is usually expressed as a percentage removal and has to be interpreted on the basis of test conditions (effects such as adsorption or stripping have to be taken into account) and duration, especially if the results are used as decision criteria for the management of an industrial sewage treatment plant.

Test type	Method	Interpretation when positive
Readily biodegradability	OECD 301 A "Die-Away" OECD 301 B $\text{CO}_2$ Evolution OECD 301 C Modified MITI (I) OECD 301 D Closed Bottle OECD 301 E Modified OECD Screening OECD 301 F Manometric Respirometry	"readily biodegradable"
Inherent biodegradability	OECD 302 A Modified SCAS OECD 302 B Zahn-Wellens/EMPA OECD 302 C Modified MITI (II) OECD 302 D Draft Concawe	"eliminable under specific sewage treatment conditions"

**Table 2.11: Selected test methods for the degradation of organic chemicals**

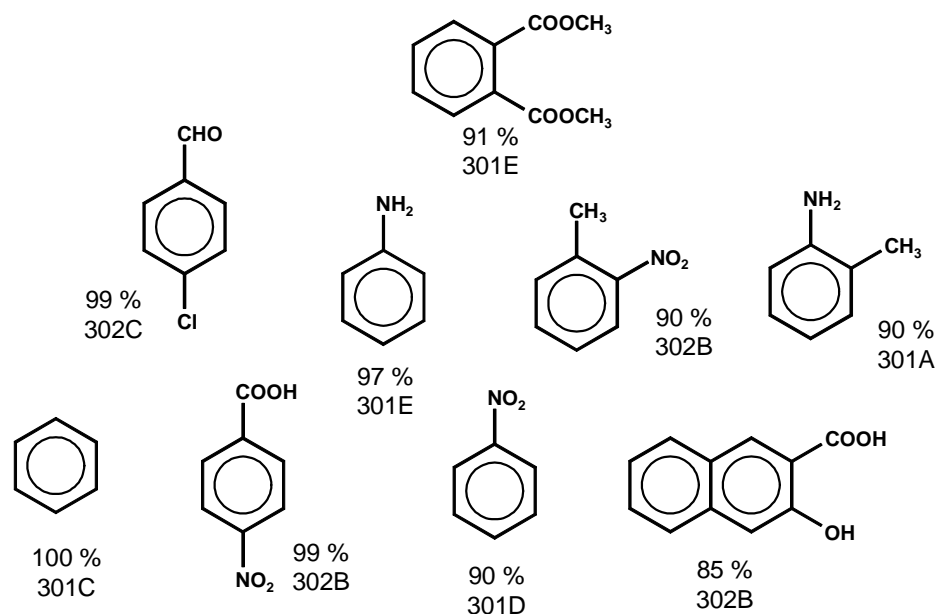

**Figure 2.9: Examples of aromatic compounds with a biodegradability of more than 80 %**  
 The percentage represents the biodegradability, the number and letter below it relates to the test method used (see Table 2.11)

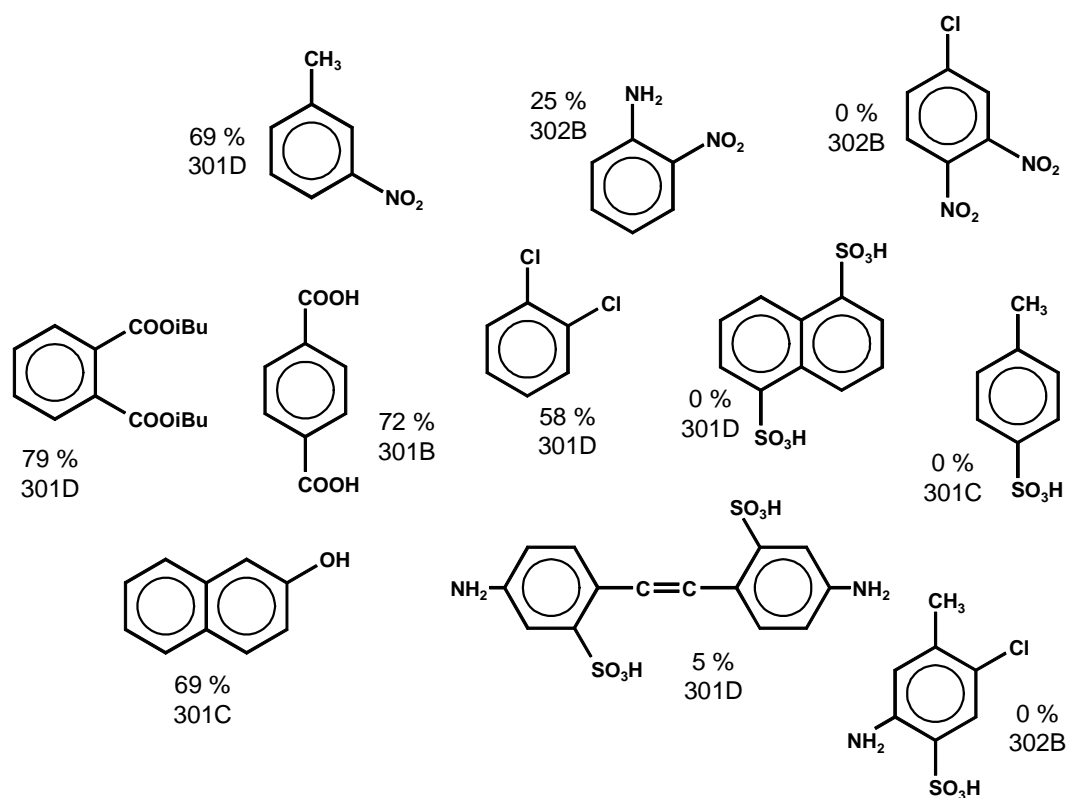

**Figure 2.10: Examples of aromatic compounds with a biodegradability of less than 80 %**  
 The percentage represents the biodegradability, the number and letter below it relates to the test method used (see Table 2.11)

## 2.5 Unit processes and connected operations

### 2.5.1 N-acylation

[6, Ullmann, 2001, 9, Christ, 1999, 16, Winnacker and Kuechler, 1982] \*010A,B,D,I,X\*

See also Section 4.3.2.1 for environmental issues and treatment of waste streams from N-acylations.

N-acylation is a widely spread reaction for the protection of anilinic amino groups before chlorinations, nitrations or sulphonations are carried out. Arylides (amides of acetoacetic acid) are important intermediates, e.g. for organic pigments.

#### Chemical reaction

The most important N-acylation agents are:

- acetic acid
- acetic anhydride, other carboxylic anhydrides
- diketene
- acetoacetic ester
- acetic chloride, other acyl halides
- N-carboxy anhydrides.

They work according to the substitution:

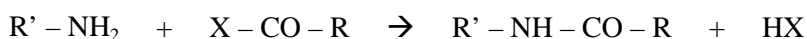

where HX is released. HX may be, e.g. H<sub>2</sub>O, CH<sub>3</sub>COOH, C<sub>2</sub>H<sub>5</sub>OH, HCl.  
(the reaction with diketene is an addition).

#### Operations

Figure 2.11 shows a typical sequence of operations for N-acylations and the typical waste streams. Amine and an equimolar amount of an acylation agent are typically dissolved in H<sub>2</sub>O or diluted acetic acid (for acetoacetic ester, xylene is often used) and heated. Reaction water or acetic acid or ethanol and solvent are distilled off and the product is obtained directly or following crystallisation (occasionally by salting out) and filtration.

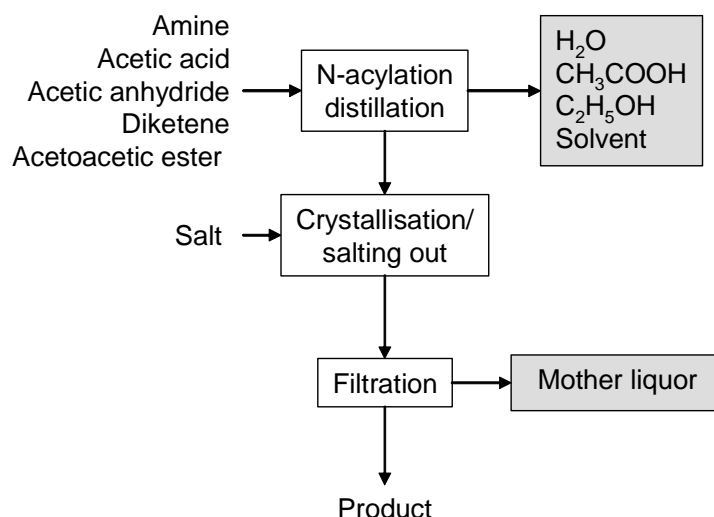

Figure 2.11: Typical sequence of operations and related waste streams from N-acylations

## 2.5.2 Alkylation with alkyl halides

[6, Ullmann, 2001, 15, Köppke, 2000]

See also Section 4.3.2.2 for environmental issues and treatment of waste streams from alkylation with alkyl halides.

Alkylations with alkyl halides are important reaction steps in industrial scale chemistry, predominantly for the synthesis of pharmaceuticals or agricultural chemicals. Some often used alkyl halides are methyl chloride, methyl iodide, ethyl chloride, isopropyl chloride, tert-butyl chloride, and benzyl chloride.

### Chemical reaction

The following equation shows an example of methylation with methyl chloride:

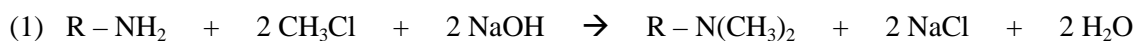

Side reactions: The effect of possible side reactions must be considered individually, but generally the use of lower alkyl halides leads to the formation of a variety of lower molecular compounds, e.g:

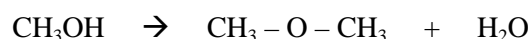
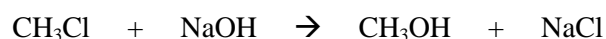

### Operations

Because alkylation reactions are diverse in nature, there is no universal method of carrying them out. The production of each compound needs to be considered individually, taking into account the chemical, engineering, and economic factors.

### 2.5.3 Condensation

[6, Ullmann, 2001, 16, Winnacker and Kuechler, 1982, 62, D1 comments, 2004]

See also Section 4.3.2.3 for environmental issues and treatment of waste streams from condensation.

Condensation represents a widely applied reaction type in industrial organic chemistry. Some examples are the manufacture of aromatic azo and poly azo compounds (intermediates for dyes and pigments) or ring closures to give heterocyclic compounds (e.g. pyrazolones, indoles, triazoles, pyrimidines, thiazoles).

#### Chemical reaction

A common feature of condensation reactions is the release of a molecule such as H<sub>2</sub>O or NH<sub>3</sub> while the reactants are coupled, e.g:

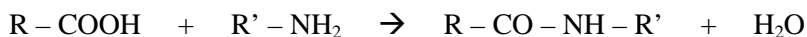

The removal of H<sub>2</sub>O is the key to shifting the equilibrium of the reaction to favour the target product.

#### Operations

Because condensation reactions are diverse in nature, there is no universal method of carrying them out. The production of each compound needs to be considered individually, taking into account the chemical, engineering, and economic factors.



## 2.5.4 Diazotisation and azo coupling

[6, Ullmann, 2001, 19, Booth, 1988, 46, Ministerio de Medio Ambiente, 2003, 51, UBA, 2004]

See also Section 4.3.2.4 for environmental issues and treatment of waste streams from diazotisation and azo coupling.

Diazotisation and coupling processes are important for the manufacture of APIs and represent the essence of azo dye manufacture. Azo dyes are the predominant colourant family, accounting for over 50 % of all commercial organic dyes. Diazotisation can also be followed by processes such as hydrazine formation, Sandmeyer reactions and azo double bond reduction.

Diazo and coupling components can be halogenated and can contribute to an AOX load in waste water streams. Often, azo coupling includes an immediate metallisation step involving heavy metals to give metal complex dyes.

### Chemical reaction

Diazotisation is the reaction of primary arylamines with nitrites, preferably with sodium nitrite, in a usually aqueous mineral acid solution at around 0 °C, whereby the amine is converted into the corresponding diazonium compound.

Weakly basic arylamines require a higher acid concentration ( $\text{NO}_2^-$  surplus), since diazoamino compounds  $\text{Ar-N=N-HN-Ar}$  may otherwise form. A further reason for using concentrated acids (e.g. concentrated sulphuric acid) is the fact that diazonium compounds of weakly basic arylamines are readily hydrolysable in dilute acids.

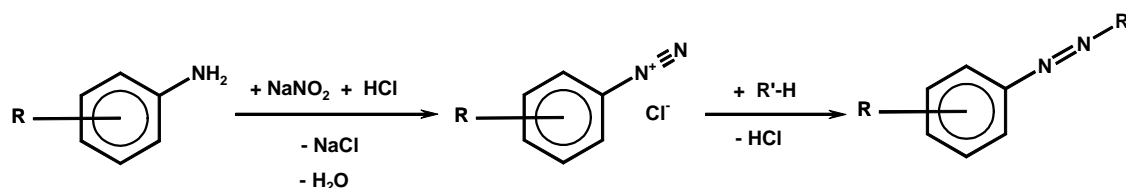

Figure 2.12: Diazotisation and azo coupling

The azo coupling reaction is an electrophilic substitution reaction of the diazonium compound with a coupling component R'H. In order to maintain an optimal reaction sequence, the pH must be kept constant by adding alkalis or buffers.

Coupling components: phenols, naphthols and amines

Side reactions: formation of diazo amino compounds  
decomposition of diazo salts to phenolic compounds  
formation of isomers  
processing of isomers contained in the starting material.

### Operations

Figure 2.13 shows a typical sequence of operations for diazotisation and azo coupling in dyestuff manufacturing.

Sodium nitrite is added in excess to a solution or suspension of the arylamine (diazo component) in a diazotisation tank. The reaction is cooled to 0 °C by adding ice or by cooling with brine. In a separate tank, the coupling component is dissolved in water and alkali. Both solutions are clarified by filtering and added to the coupling vessel. The addition sequence depends on the particular case, and the precise reaction conditions (pH, temperature) are established by the addition of alkali or ice.

Clarifying may be necessary on completion of the reaction (by filtration over  $\text{SiO}_2$ ,  $\text{Al}_2\text{O}_3$  or charcoal) to remove unreacted amine and salty, resin-like or oily by-products, followed by precipitation of the product (usually by salting out or pH change), filtration, washing, dissolving and, e.g. spray drying to yield the standardised dyestuff. Alternatively, the reaction mixture is immediately passed through a pressure permeation (see also Section 4.2.26), followed by, e.g. belt, spin flash, spray or oven drying.

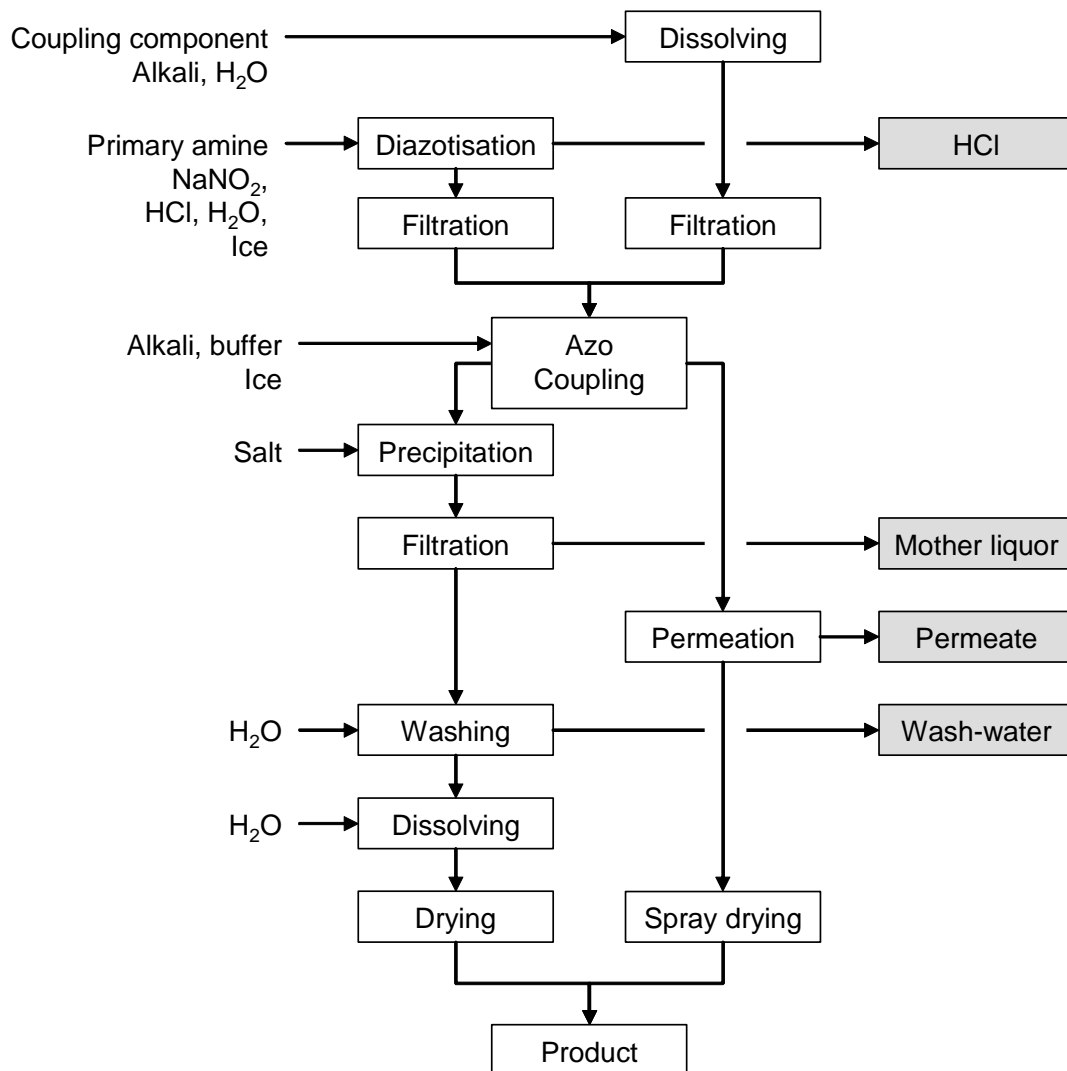

**Figure 2.13: Typical sequence of operations for diazotisation and azo coupling**  
Possible input materials (on the left) and the associated waste streams (grey background)

### 2.5.5 Esterification

[6, Ullmann, 2001]

Organic esters are of considerable economic importance. Because of their highly lipophilic and hydrophobic nature and low polarity, esters are widely used as solvents, extractants, and diluents. Ethyl acetate is the most common technical solvent. Large quantities of esters, especially phthalates, adipates, and fatty acid esters, are used as plasticisers. Esters with a pleasant odour are used in fragrances, flavours, cosmetics, and soaps. Esters can be converted into various derivatives and are useful intermediates in the synthesis, e.g. of vitamins or pharmaceuticals.

#### Chemical reaction

A great variety of production methods for carboxylic acid esters are known, but the simplest and most common method of esterification is the reaction of an alcohol with a carboxylic acid with the elimination of water:

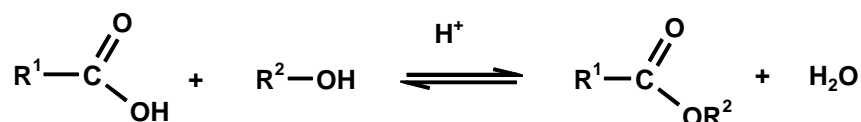

Figure 2.14: Common esterification

Esterification is the reverse of hydrolysis and leads to an equilibrium reaction, which is the reason that quantitative esterification is possible only by continuous removal of one of the products, i.e. ester or water. In the case of transesterification, an alcohol is released instead of water.

Suitable catalysts are sulphuric acid, hydrogen chloride, arylsulphonic acids such as p-toluenesulphonic acid, and chlorosulphuric acid. Phosphoric acid, polyphosphoric acids, and mixtures of acids are also recommended. If the acids are adsorbed on a solid support, esterification can be carried out as a continuous process.

Removal of water usually involves the addition of entrainers, which form azeotropes with relatively low boiling points and high water contents (usually toluene, xylene, cyclohexane, seldom also benzene or CCl<sub>4</sub>).

#### Operations

The reaction is generally carried out by refluxing the reaction mixture until all the water has been split off. The water or the ester is removed from the equilibrium by distillation. Water is usually removed by distillation of the azeotrope with the alcohol or an entrainer. After condensation, the azeotrope separates into an aqueous phase and an organic phase, and the entrainer or alcohol is recycled into the reaction mixture. In particular cases, a co-solvent such as benzene or toluene is added to the condensate to achieve separation of the organic phase.

Many esters are produced continuously in pipes, distillation columns or plate columns. Ion-exchange resins are especially suitable as catalysts in continuous processes. The reactants pass through or over the solid catalyst, and no separation or neutralisation of the catalyst is necessary.

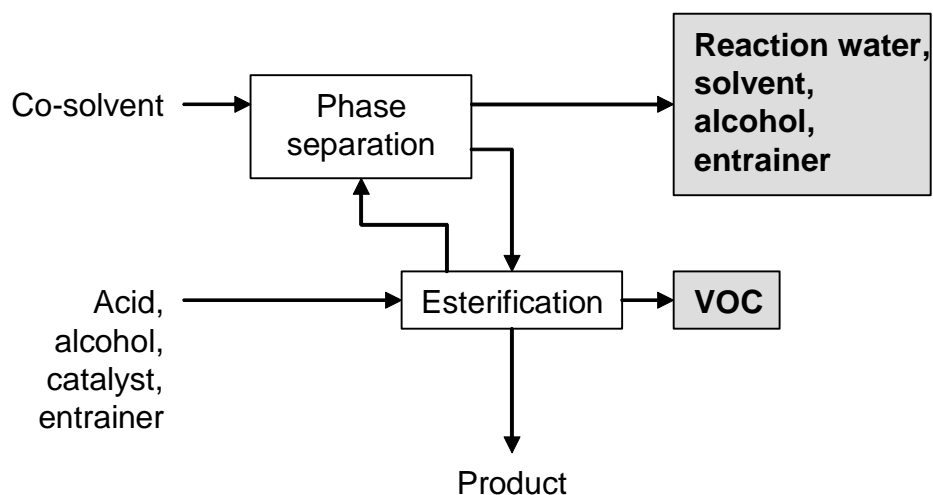

**Figure 2.15: Typical sequence of operations for esterification**  
Possible input materials (on the left) and the associated waste streams (grey background)

### Environmental issues

Table 2.12 gives some example data for waste water streams from esterifications. Figure 2.16 shows the applied abatement techniques.

Waste water stream	Properties		
Bioeliminability of organic esters			
	BOD <sub>5</sub> mg/l	DOC elimination after 7 days (Static test) in %	Reference
Methyl acetate	500	>95	[6, Ullmann, 2001]
Ethyl acetate	770	>90	
Vinyl acetate	810	>90	
Butyl acetate	1000	>95	
2-Methoxyethyl acetate	450	100	
2-Butoxyethyl acetate	260	100	
2-(2-Butoxyethoxy)ethyl acetate	380	100	
Methylaceto acetate	940	100	
Ethylaceto acetate	780	>90	
n-Butyl glycolate	570	93	
Methyl crotonate	1050	>95	
Dimethylacetyl succinate	1100	>95	
Diethylacetyl succinate	1070	>95	
Dimethyl maleate	20	100	
Monomethyl maleate	150	>95	
Diethyl maleate	200	>90	
Dibutyl maleate	630	99	
Di(2-ethylhexyl) maleate	1450	100	
Methyl-3-amino benzoate	10	95	
Methyl-4-hydroxy benzoate	1080	100	
Methyl-4-hydroxyphenyl acetate	320	98	

**Table 2.12: Example data for waste water streams from esterification**

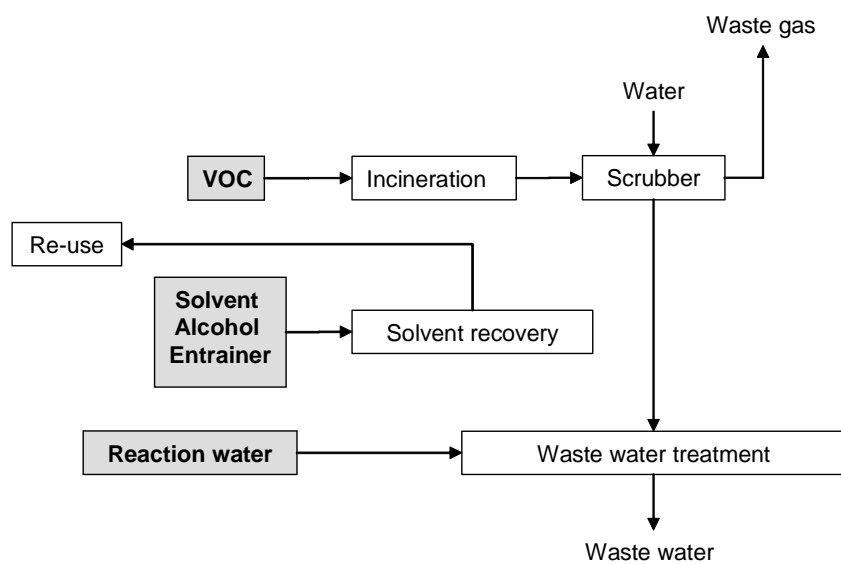

Figure 2.16: Applied abatement techniques for the waste streams from esterification

## 2.5.6 Halogenation

[6, Ullmann, 2001, 15, Köppke, 2000, 16, Winnacker and Kuechler, 1982, 18, CEFIC, 2003]

See also Section 4.3.2.5 for environmental issues and treatment of waste streams from halogenations.

Halogenation is one of the most important and versatile processes in chemistry. The industrial application is dominated by chlorinations, due to the different reactivity and the higher price for bromine, iodine and fluorine.

Side chain chlorinated alkyl aromatics, particularly those based on toluene and xylene, as well as nucleus halogenated aromatics, have an exceptional place in organic fine chemistry, because of their role as chemical intermediates in the manufacture of chemical products of almost all kinds, including dyes, plastics, pharmaceuticals, flavours and fragrances, pesticides, catalysts and inhibitors.

Bromination is a key process in anthraquinone chemistry and the manufacture of organic flame-retardants.

### Heavily halogenated aromatic hydrocarbons

Especially as a result of the environmental persistence of the heavily chlorinated benzenes, toluenes and biphenyls, in recent years drastic measures have been applied to this range of chemicals, such as prohibitions, and restrictions on their production and use, and legislation regulating waste disposal. Possible side reactions of the chlorination process can result in the formation of polychlorinated biphenyls or hexachlorobenzene. The combustion of aromatics containing chlorine can lead to the formation of polychlorodibenzo dioxins/-furans (PCDD/PCDF).

### Chemical reaction

These chemicals are of major relevance on an industrial scale in substitutions of the aromatic nucleus and in the substitution of aliphates. In both cases, hydrogen is replaced by halogen (X) and the related hydrogen halide is created:

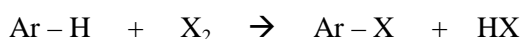
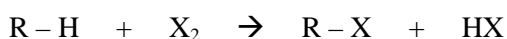

Both reactions are exothermic but the aliphate substitution follows a radical chain mechanism, initialised by ultraviolet light (irradiation with mercury vapour lamps), while the halogenation of the aromatic nucleus is based on an electrophilic mechanism supported by Friedel-Crafts catalysts (i.e. Lewis acids such as  $\text{FeCl}_3$ ,  $\text{AlCl}_3$  ...).

Generally, a mixture of isomers and/or compounds with a different degree of halogenation is obtained and side reactions following alternative mechanisms cannot be completely suppressed. The product mix depends on the aromatic/halogen ratio, the reaction conditions and the choice of the catalyst.

A wide range of organic and aqueous solvents are currently in use, and especially tetrachloromethane, tetrachloroethane, dichlorobenzene and trichlorobenzene are recommended for halogenations [6, Ullmann, 2001].

Bromine is more efficiently used in aromatic substitution reactions if it is generated *in situ* from hydrogen bromide using chlorine:

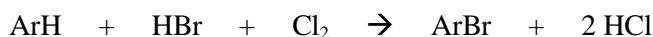

Another approach is the use of an alcohol as the solvent to co-produce an economically useful alkyl bromide, by the reaction of by-product HBr with the alcohol. Methanol is the solvent of choice since the resulting methyl bromide can be widely marketed as a fumigant.

### Side chain chlorination of toluenes

Side chain chlorination is applied in particular to toluenes, to give the analogue benzyl chlorides, benzyl dichlorides and benzyl trichlorides. The reaction follows the radical chain mechanism and leads in every chlorination step to the formation of hydrogen chloride. The process yields a mixture of all three products, with the product mix depending mainly on the toluene/chlorine ratio.

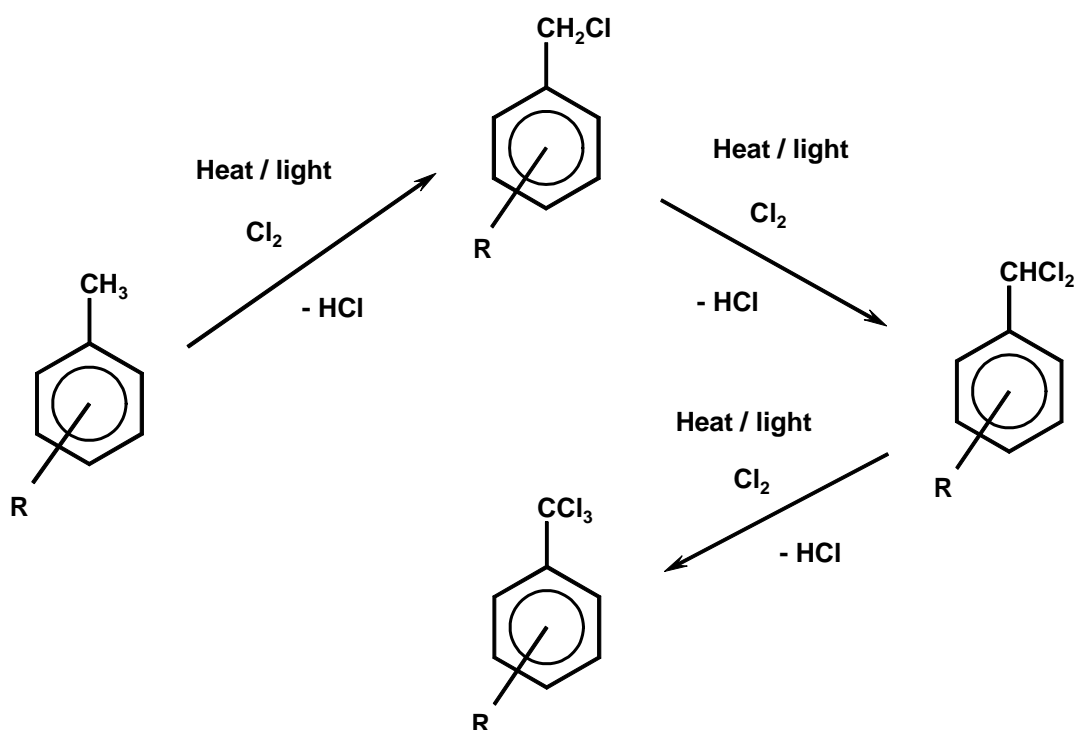

Figure 2.17: Side chain chlorination of toluene derivatives

Possible side reactions can yield polychlorobiphenyls or hexachlorobenzene as shown in the following equations:



A common following step is the partial hydrolysis of the obtained products to the analogue benzaldehydes or benzoyl chlorides by alkaline or acidic agents.

## Operations

Figure 2.18 shows a typical sequence of operations for the halogenation to distillable products. Figure 2.19 shows a typical sequence of operations for the halogenation precipitation of the product.

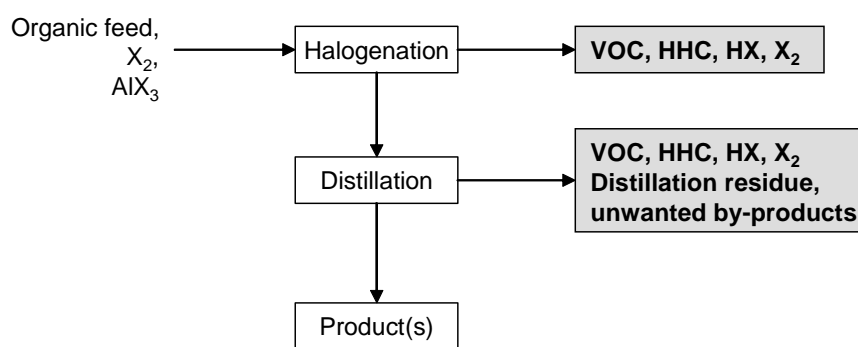

**Figure 2.18: Typical sequence of operations for the halogenation to distillable products**  
Possible input materials (on the left) and the associated waste streams (grey background)

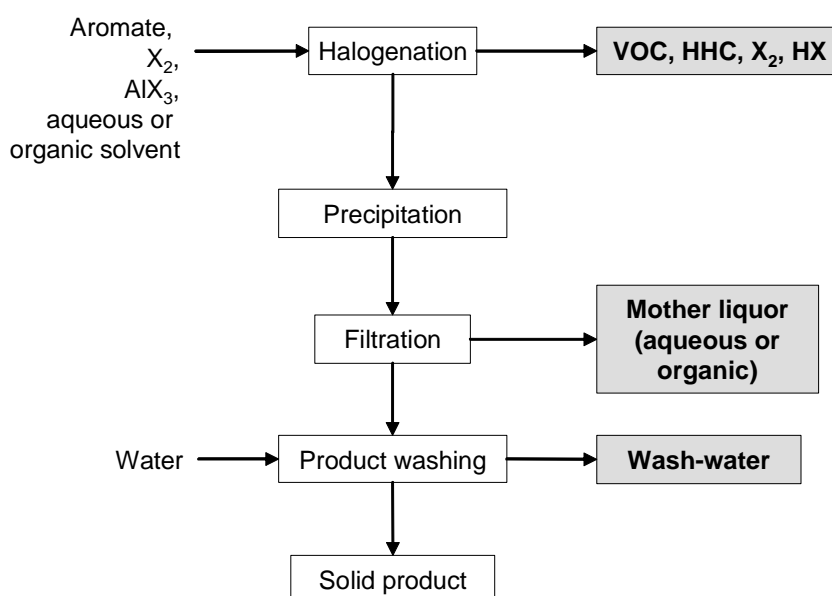

**Figure 2.19: Typical sequence of operations for halogenation with precipitation of the products**  
Possible input materials (on the left) and the associated waste streams (grey background)

In a typical batch reaction, the halogen is added to the stirred aromatic or a stirred aromatic solution. The reactor material depends on the reactants and the chosen reaction mechanism. The exothermic reaction is controlled by the rate of halogen addition, which is dependent on the refrigeration capacity of the reactor cooling system. The choice of temperature profile is based on the reactivity of the aromatic. On completion of the reaction, degassing is carried out with nitrogen. The product is distilled or precipitated (e.g. by cooling or water addition) and the resulting slurry is filtered, washed and dried.

Most side chain chlorinations are carried out continuously or discontinuously in bubble column reactors of enamel or glass, e.g. of the loop type. The reactor is filled with the starting material, heated to at least 80 °C and chlorine is introduced until the desired degree of chlorination is reached. The reaction is stopped by the introduction of N<sub>2</sub>. Products of different degrees of chlorination are separated by distillation to be directly marketed, hydrolysed to give the related benzaldehydes or benzoic acids/benzoyl chlorides, or are used for further chlorination.



## 2.5.7 Nitration

[6, Ullmann, 2001, 15, Köppke, 2000, 16, Winnacker and Kuechler, 1982, 18, CEFIC, 2003, 46, Ministerio de Medio Ambiente, 2003]

For environmental issues and treatment of waste streams, see Section 4.3.2.6.

Liquid phase nitration is a dominant step in the manufacture of common high explosives and important for the production of a wide range of aromatic intermediates for dyes, agrochemicals, pharmaceuticals or other fine chemicals. A typical nitration reaction is highly exothermic, therefore, for a safe mode of reaction, a dosage controlled process with precautions securing no accumulation of reactants is necessary. Typical nitroaromatic production is based on high yield processes, with more than 80 % of the total cost being the cost of the raw materials. Integral requirements of all efficient nitration processes are sulphuric acid regeneration and isomer control and separation. Nitration of the important naphthalene mono- and disulphonic acids is usually performed with the formed sulphonated mass. Among the typical raw materials are halogenated aromatics, which can contribute to the AOX load of waste water streams.

### Chemical reaction

Nitration is the irreversible introduction of one or more nitro groups into an aromatic system by electrophilic substitution of a hydrogen atom. O-nitration to give nitrates and N-nitration to give nitramines are far less important for aromatic compounds but relevant for the manufacture of explosives.

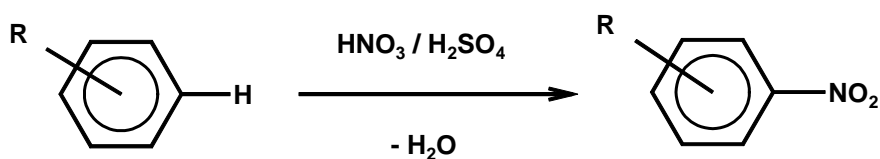

**Figure 2.20: Nitration of an aromatic compound**

Nitration is normally carried out in a liquid phase reaction with a mixture of nitric and sulphuric acids (mixed acid) and occasionally with nitric acid. A typical mixed acid, for example for mononitration, consists of 20 % nitric acid, 60 % sulphuric acid and 20 % water (this is referred to as 20/60/20 mixed acid). The strength of the mixed acid and the temperature can be varied to maximise the formation of the required isomer. Stronger mixed acid and higher temperature lead to oxidative side reactions. An important side reaction leads to phenolic by-products.

### Operations

Figure 2.21 shows a typical sequence of operations for the nitration of aromatic compounds, possible input materials and associated waste streams. The reaction is carried out in cast iron, stainless steel or enamel-lined mild steel reactors. Temperatures vary normally between 25 and 100 °C. The substrate is dissolved in the sulphuric acid phase and the mixed acid is subsequently added. On completion of the reaction, the batch is transferred into water to give a two phase mixture of diluted acid and an organic product phase.

After phase separation, liquid products are purified by distillation. The remaining acid phase can be extracted with the feed material in order to recover organic compounds. Solid products are crystallised (where necessary, by the addition of cold water). The crude nitroaromatic is washed with water and diluted NaOH to remove the acids and phenolic by-products. Depending on the quality requirements, a recrystallisation from water or organic solvent may be necessary. Isomer separation is carried out within the crystallisation, washing or distillation steps.

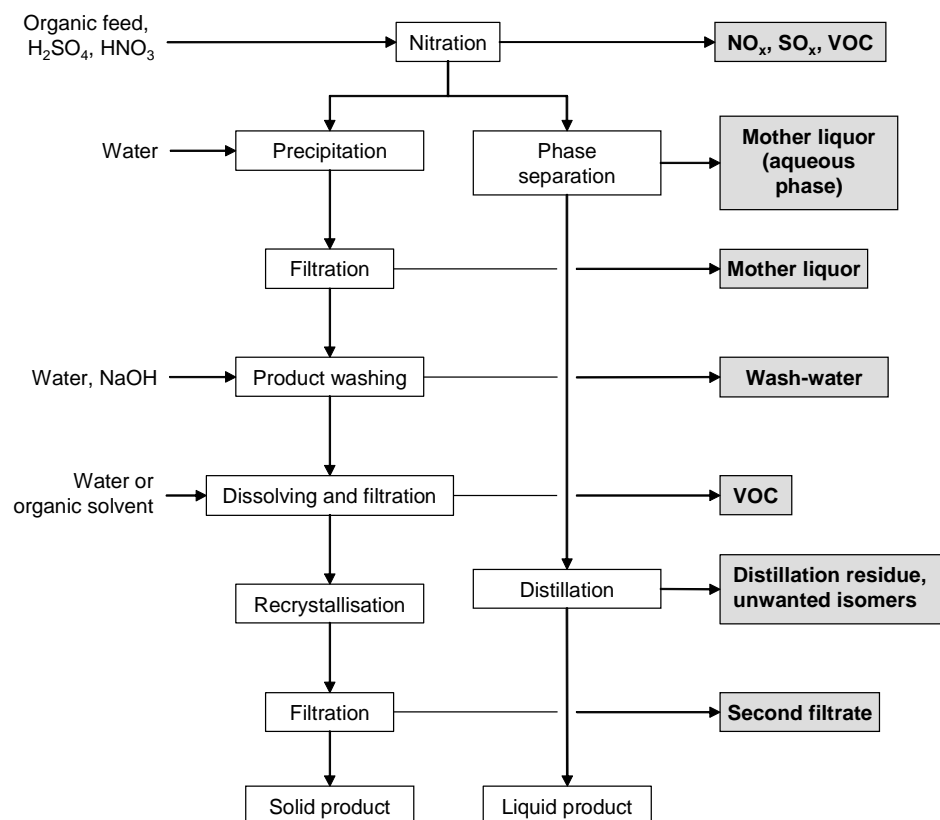

**Figure 2.21: Typical sequence of operations for a nitration**  
Possible input materials (on the left) and the associated waste streams (grey background)

## 2.5.8 Manufacture of nitrated alcohols

[46, Ministerio de Medio Ambiente, 2003], \*026E\*

Figure 2.22 shows a typical setup for the manufacture of nitrated alcohols, e.g. nitroglycol or nitrocellulose.

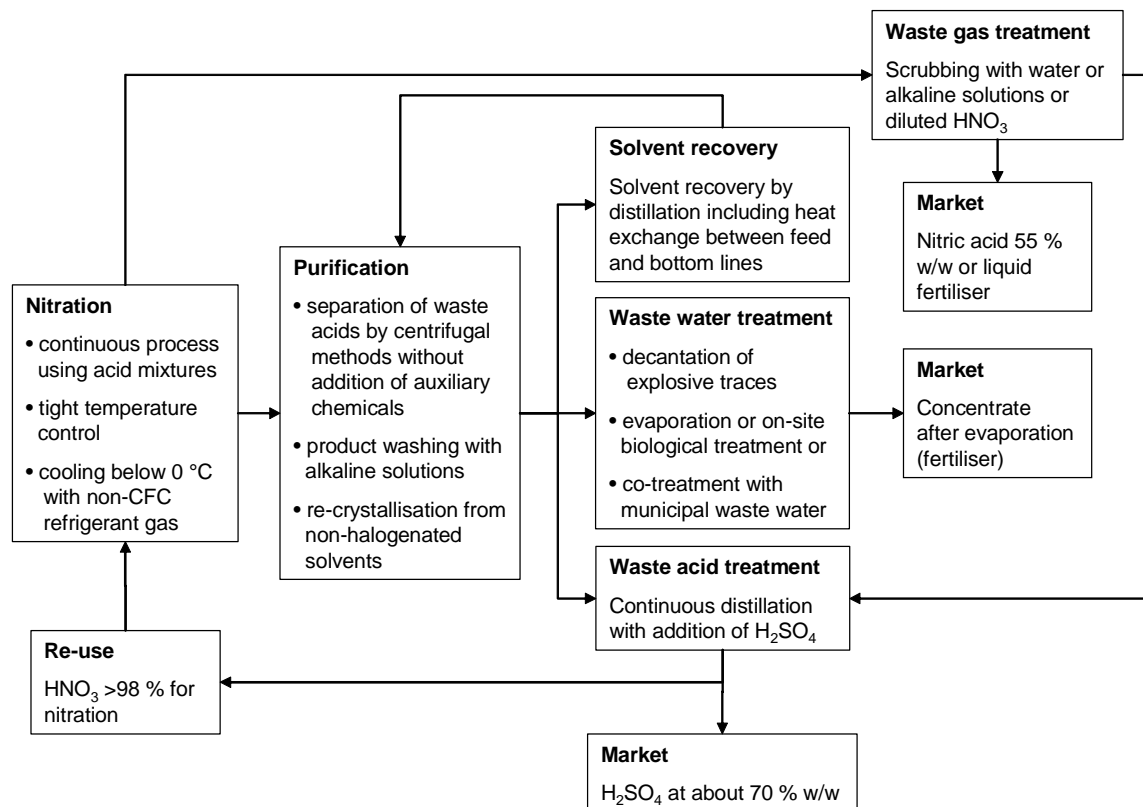

Figure 2.22: Typical setup for the manufacture of nitrated alcohols

### Waste explosives

Waste explosives are obtained in the decanters and in the cleaning of installations. Some waste explosives may also be produced during the malfunction of production equipment. Other explosive waste comes from obsolete products, i.e. those not useful for customers. All kinds of waste explosives are packaged in suitable containers and then carefully destroyed by open air combustion or by open detonation in authorised installations. Combustion of waste explosives is carried out in treatment zones with secondary containment, in order to collect the ashes and allow disposal of them by a waste treatment contractor.

### 2.5.9 Oxidation with inorganic agents

[6, Ullmann, 2001, 16, Winnacker and Kuechler, 1982, 43, Chimia, 2000, 44, Hörsch, 2003]

Chemical oxidation with inorganic agents is still industrially important, due to the fact that reactions with molecular oxygen are usually considerably less selective and generally require much higher investment, thereby only becoming economically worthwhile for capacities above about 10000 tonnes per year, depending on the product.

#### Overview

Table 2.13 gives an overview of the main aspects important in the selection of a suitable oxidation agent, the related by-products and some other characteristics. In the case of  $\text{CrO}_3$  and  $\text{MnO}_2$ , the agent by-products are often regenerated [99, D2 comments, 2005].

Agent	Target molecules	Agent by-product	Typical solvents/ other aspects
$\text{CrO}_3$ "Chromic acid"	Benzoic acids, benzaldehydes	$\text{Cr}_2\text{O}_3$	Acetic acid, acetic anhydrides
$\text{KMnO}_4$	Benzoic acids, benzaldehydes	$\text{MnO}_2$	
$\text{MnO}_2$	Benzaldehydes	$\text{Mn}^{2+}$	Aqueous $\text{H}_2\text{SO}_4$
$\text{HNO}_3$	Benzoic acids	$\text{NO}_x$	<i>In situ</i> regeneration of NO to $\text{HNO}_3$ with oxygen
$\text{NaOCl}$	Stilbenes	$\text{NaCl}$	
$\text{Cl}_2$	Sulphones, sulphochlorides, chloranil	$\text{HCl}$	

**Table 2.13: Overview of oxidations with inorganic agents**

#### Environmental issues

Table 2.14 gives some example data for the waste streams from oxidations. The main environmental issues are:

- exhaust gases, possibly containing VOCs,  $\text{NO}_x$  or  $\text{HCl}$
- solid agent by-product, containing heavy metals
- mother liquors, possibly containing high loads of organic by-products and heavy metals, and high AOX loads when  $\text{Cl}_2$  or  $\text{NaOCl}$  are used.

Waste stream	Properties
Oxidation of 3-picoline with chromic acid [43, Chimia, 2000]	
Inorganic solid residues	1.7 to 2.0 tonnes $\text{Cr}_2\text{O}_3$ per tonne product
Oxidation of 3-picoline with $\text{KMnO}_4$ [43, Chimia, 2000]	
Inorganic solid residues	4.0 tonnes $\text{MnO}_2$ per tonne product
Manufacture of 4,4'-dinitrostilbene – 2,2'-disulphonic acid [44, Hörsch, 2003]	
Mother liquors	COD: 28400 mg/l AOX: 230 mg/l BOD <sub>28</sub> /COD: 0.04

**Table 2.14: Example data for the waste streams from oxidations**

### 2.5.10 Phosgenation

[45, Senet, 1997]

About 300000 tonnes of phosgene is used each year in the manufacture of agrochemicals, pharmaceuticals, dyestuffs and polymerisation initiators. Phosgene is usually used as a building block to introduce a carbonyl function or as an agent, e.g. for chlorination or dehydrogenations.

#### Chemical reaction

Phosgenation follows a nucleophilic or Friedel-Crafts related mechanism, depending on the conditions:

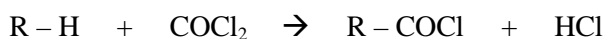

Its use as a chlorination or dehydrogenation agent additionally involves the formation of stoichiometric amounts of CO<sub>2</sub>.

#### Operations

Because phosgenation reactions are diverse in nature, there is no universal method of carrying them out. The production of each compound is thus considered individually, assessing the chemical, engineering, and economic factors.

#### Safety issues

The main safety aspect of the phosgenation reaction is related to the high toxicity of phosgene. Table 2.15 compares phosgene to some other toxic gases.

Gas	Odour identification	L(CT) 0 – 30 min exposure
		ppm
Phosgene	1.5	10
Chlorine	1	873
Carbon monoxide	No	4000
Ammonia	5	30000

**Table 2.15: Comparison of some toxic gases**

Due to these high toxicity properties, the handling and storage of phosgene on an industrial scale on a site must be strictly treated as a major hazard and such sites may fall – depending on the amount of phosgene handled – under the regime of the Council Directive 96/82/EC (last modification by Directive 2003/105/EC) on the control of major accident hazards involving dangerous substances. Therefore, custom synthesis in specialised companies is a common practice in this field.

For measures to limit the risks arising from the handling of phosgene, see Section 4.2.30.

### 2.5.11 Reduction of aromatic nitro compounds

[6, Ullmann, 2001, 16, Winnacker and Kuechler, 1982, 19, Booth, 1988]

For environmental issues and treatment of waste streams, see Section 4.3.2.7.

One of the most industrially important reduction processes in industrial use is the conversion of an aromatic nitro or dinitro compound into an arylamine or arylene diamine. Aromatic amines are widely used as dye intermediates, especially for azo dyes, pigments, and optical brighteners; as intermediates for photographic chemicals, pharmaceuticals, and agricultural chemicals; in polymers via isocyanates for polyurethanes; and as antioxidants. Among reduction methods, there are three of major relevance in organic fine chemistry:

- catalytic hydrogenation, which is extremely important industrially because of its universal applicability; most processes can be carried out successfully by catalytic hydrogenation
- Béchamp and Brinmeyr reduction with iron, which is the classical method
- alkali sulphide reduction, which is the selective method in specific cases, such as in the manufacture of nitroamines from dinitro compounds, the reduction of nitrophenols, the reduction of nitroanthraquinones and the manufacture of aminoazo compounds from the corresponding nitroazo derivative.

All three methods are also applied to halogenated nitro compounds, and can thus contribute to AOX loads in waste water streams.

#### 2.5.11.1 Catalytic reduction with hydrogen

##### Chemical reaction

The catalytic reduction of the nitro compounds is very exothermic. To reduce these hazards, the concentration of nitro compound, the amount and partial pressure of the hydrogen, the temperature, and the activity of the catalyst, are controlled.

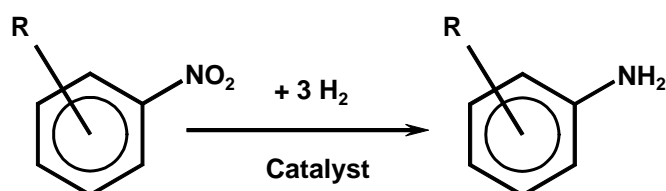

Figure 2.23: Catalytic reduction of aromatic nitro compounds

Most aromatic nitro compounds are hydrogenated in the liquid phase. In this case, the pressure and temperature can be changed independently. The temperature is limited by the hydrogenation reaction of the aromatic ring which occurs above 170 – 200 °C.

Normally, the reduction is carried out at 100 – 170 °C. Sensitive compounds are hydrogenated at lower temperatures (20 – 70 °C) or at lower pressures (1 – 50 bar). 1 – 50 bar are used normally.

**Process hazards**

The catalytic reduction of nitro compounds is very exothermic. Unless this heat is dissipated properly, decomposition and even explosions can result, especially if the thermal decomposition of the nitro compound occurs or if condensation reactions are initiated as may be the case with chloro-nitro compounds. The industrial hydrogenation of aromatic polynitro compounds in the liquid phase without solvents especially requires precautions. To reduce these hazards, the concentration of the nitro compound, the amount and partial pressure of the hydrogen, the temperature, and the activity of the catalyst are controlled. The nitro compound is continuously added in small quantities, thus keeping its concentration below 2 %. De-ionised water is added to remove the heat of the reaction by continuous evaporation and to slow down the activity of the catalyst.

The preferred solvents are methanol and 2-propanol; and also dioxane, tetrahydrofuran, and N-methylpyrrolidone are used. In the hydrogenation with a water immiscible solvent, such as toluene, the water must be removed, as in solvent-free hydrogenation, in order to maintain the activity of the catalyst. If the amine has a good water solubility, water is used as the solvent. Water also can be used in cases where the nitro compound forms water-soluble salts with alkalis, such as with nitrocarbonic or sulphonic acids. In practice, only Raney nickel, Raney nickel-iron, Raney cobalt, and Raney copper are used as pure metal catalysts because of their relatively low cost. Precious metal catalysts, such as Pt and Pd, are generally used at concentrations of 0.5 – 5 wt-% on support material with large surfaces, such as charcoal, silica, aluminium oxide, or alkaline-earth carbonates.

**Operations**

The vast majority of aromatic amines have small annual volumes (<500 tonnes) and are produced by batch hydrogenation with catalyst slurries. The reaction is carried out in stirred, steel or stainless steel autoclaves or in loop reactors. Loop reactors show increased heat and mass transfers and improved reaction selectivity, shorter batch cycle times and higher product yields. In addition, catalyst usage is often lower. The addition sequence depends on the particular reactants. On completion the reaction mass is cooled and the catalyst is removed by filtration.

**2.5.11.2 Reduction with iron****Chemical reaction**

The reduction of nitroaromatics is carried out in the presence of small amounts of acid (HCl, H<sub>2</sub>SO<sub>4</sub>, HCOOH, CH<sub>3</sub>COOH) as shown in the following equation:

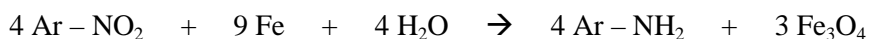

The acid is used for the activation of the iron. Only 2 – 3 % of the hydrogen is derived from the acid but 97 – 98 % comes from the water.

**Operations**

Normally the nitroaromatic is added to the mixture of iron/water/acid (excess of iron about 15 - 50 %) often in the presence of an organic solvent (toluene, xylol, alcohols) and the mixture is heated to reflux. Depending on the reactivity of the aromatic, other addition sequences may be required. In some cases the acid is omitted (neutral iron reduction). The build-up of unreduced excess nitro compound must be avoided and the final mixture should be tested for its total absence. After basification with soda ash (anhydrous sodium carbonate) to precipitate soluble iron, the iron compounds are removed by filtration.

### 2.5.11.3 Alkali sulphide reduction

#### Chemical reaction

The alkali sulphide reduction is a mild and selective reaction according to the following equation, without strict stoichiometry:



Other reducing agents in use are  $\text{Na}_2\text{S}$  or  $\text{NaSH}$ , which also form  $\text{Na}_2\text{S}_2\text{O}_3$ . Sulphur may be added to reduce the required amount of sulphide.

#### Operations

Dilute aqueous sulphide is added to the solution or emulsion of the nitro compound. Temperatures (in the range of 80 – 100 °C) and concentrations depend on the reactivity of the nitroaromatic. An excess of sulphide is avoided in the case of the selective reduction of polynitro compounds.

### 2.5.11.4 Product work-up

Figure 2.24 shows a typical sequence of operations for the reduction of aromatic nitro compounds, possible input materials and associated waste streams. The work-up depends on the properties of the amine obtained. Common methods are:

- separation as a liquid
- cooling and salting out
- steam distillation
- extraction with organic solvent, and
- pH adjustment if necessary.

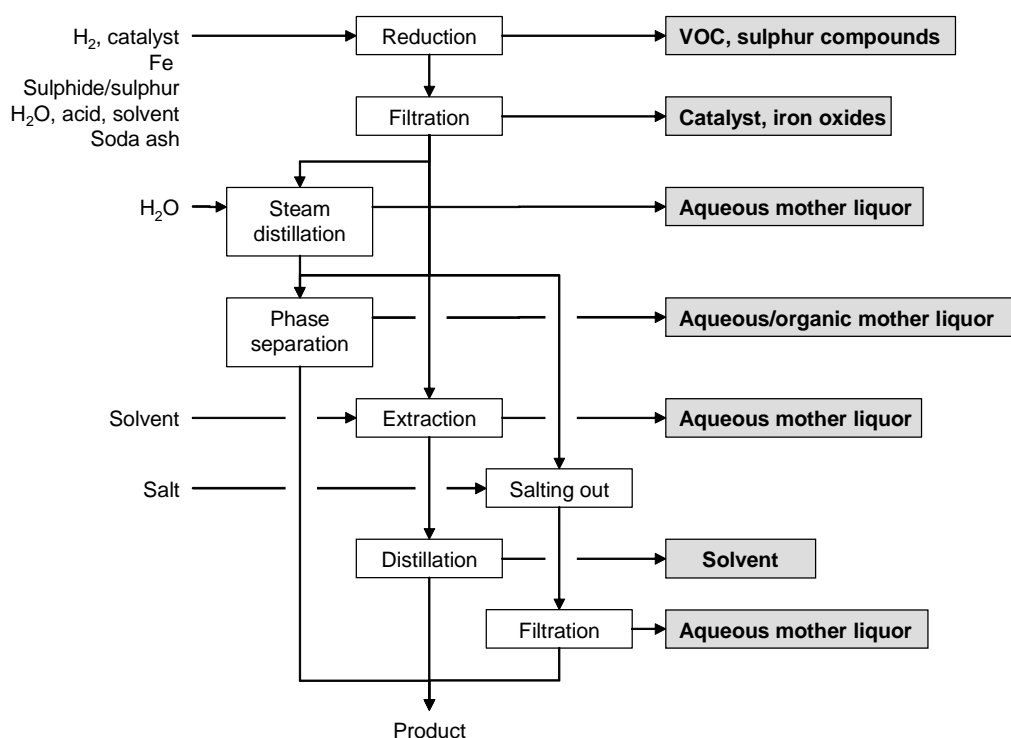

Figure 2.24: Typical sequence of operations for the reduction of an aromatic nitro compound  
Possible input materials (on the left) and the associated waste streams (grey background)



### 2.5.12 Sulphonation

[6, Ullmann, 2001, 15, Köppke, 2000, 16, Winnacker and Kuechler, 1982, 46, Ministerio de Medio Ambiente, 2003]

For environmental issues and treatment of waste streams, see Section 4.3.2.8.

The direct introduction of the sulphonic acid group to an aromatic system is one of the most important reactions in industrial organic chemistry. It gives high yields under relatively mild conditions and usually results in well defined derivatives. Arylsulphonic acids are used chiefly as intermediates in the manufacture of dyes, insecticides, pharmaceuticals, plasticisers, optical brighteners, etc. Among the typical raw materials are also halogenated compounds, thus contributing to the AOX load of waste water streams.

#### Chemical reaction

Sulphonation is usually carried out with concentrated sulphuric acid in excess of about 50 to 100 % or using oleum. Due to the fundamental rules of electrophilic aromatic substitution, the product is a mixture of the target molecule and isomers. The reaction is reversible, with the yield and isomer distribution depending on the reaction conditions (e.g. temperature, removal of reaction water by azeotrope distillation or addition of thionyl chloride).

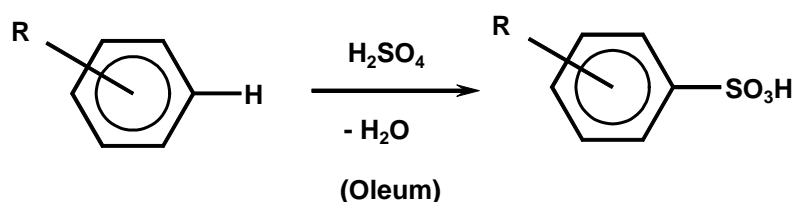

Figure 2.25: Sulphonation of an aromatic system

Increased temperature and reaction water removal also favour the formation of sulphones as by-products. Depending on the reactants (aromatic,  $\text{H}_2\text{SO}_4$ , oleum) and temperature, the oxidative effects of sulphuric acid or sulphur trioxide can lead to unwanted oxidation reactions.

#### Operations

Figure 2.26 shows a typical sequence of operations for sulphonation, possible input materials and associated waste streams. The reaction is carried out at temperatures of about 60 to 90 °C in cast steel or enamelled steel vessels. The sulphonating agent is fed into the vessel, the aromatic compound is then added, and the reaction is controlled by means of temperature profiles or metering.

On completion of the reaction, the batch is transferred into water, which causes unconverted aromatic compounds to be released. The dilute sulphonation mass is cooled, and the free acid is separated by filtration. For further purification, recrystallisation may be necessary.

If the free acid is too soluble and isolation is not possible in this way, other techniques are carried out, such as:

- salting out with sodium sulphate or sodium chloride
- temperature controlled crystallisation, or
- reactive extraction.

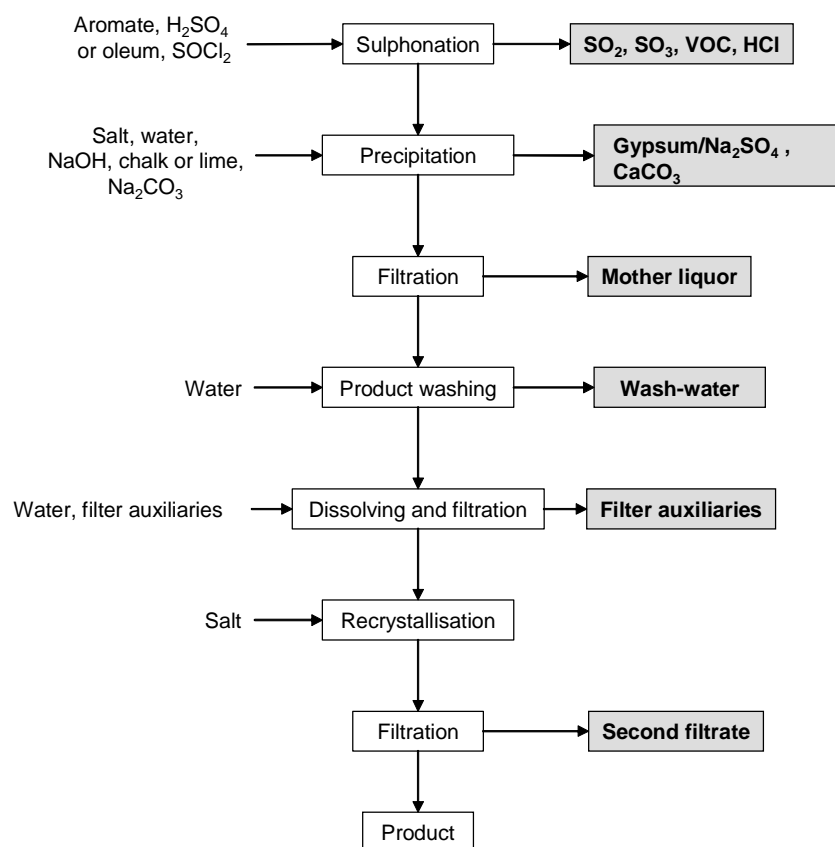

**Figure 2.26: Typical sequence of operations for a sulphonation**  
Possible input materials (on the left) and the associated waste streams (grey background)

In the reactive extraction process, the unconverted sulphuric acid is recovered by converting the arylsulphonic acid into its ammonium salt with a long-chain aliphatic amine. This salt is separated from the sulphuric acid as a liquid phase and then converted with sodium hydroxide solution into sodium sulphonate solution and the amine; the latter can be separated as a liquid phase and can be re-used. Sulphonates practically free from inorganic salts are obtained in this way.

Other isolation methods are based on the neutralisation of the excess sulphuric acid by adding calcium carbonate or sodium hydroxide. This leads to a large amount of gypsum (“liming” or “chalking”) or sodium sulphate, which is removed in the hot state. In liming, the dissolved calcium arylsulphonate is then treated with soda and the precipitated calcium carbonate is removed by filtration. The filtrate contains the sodium arylsulphonate.

### 2.5.13 Sulphonation with SO<sub>3</sub>

[15, Köppke, 2000]

For environmental issues and the treatment of waste streams, see Section 4.3.2.9.

Sulphonation with SO<sub>3</sub> is applied in the manufacture of a smaller number of aromatic sulphonic acids produced in higher volumes.

#### Chemical reaction

Sulphonation with SO<sub>3</sub> is illustrated in Figure 2.27. The reaction does not lead to the formation of reaction water and shows higher selectivity if carried out at lower temperatures.

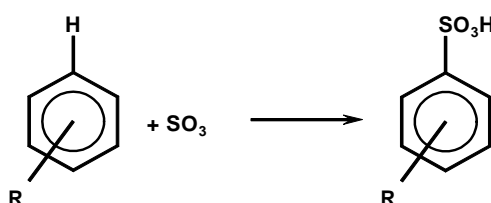

Figure 2.27: Sulphonation with SO<sub>3</sub>

Side reactions:

- formation of sulphones
- formation of isomers
- formation of oxidation by-products.

If carried out as a liquid phase reaction, halogenated compounds serve as solvents (e.g. methylene chloride or dichloroethane).

#### Operations

Figure 2.28 and Figure 2.29 show typical sequences of operations, possible input and related waste streams from the reaction in liquid phase and the gas-liquid reaction.

##### Liquid phase reaction

Both, the organic feed and SO<sub>3</sub> are dissolved in organic solvents (e.g. methylene chloride or dichloroethane) and continuously added to the reactor. On completion, the reaction mixture is transferred into water and cooled. The organic phase is segregated and the product is precipitated from the aqueous phase by cooling and addition of sulphuric acid with subsequent filtration.

##### Gas-liquid reaction

Depending on the local conditions, SO<sub>3</sub> gas is derived directly from a sulphuric acid facility or generated by combustion of sulphur. The reaction is usually carried out in falling film reactors. In many cases, it is not necessary to perform further work-up steps.

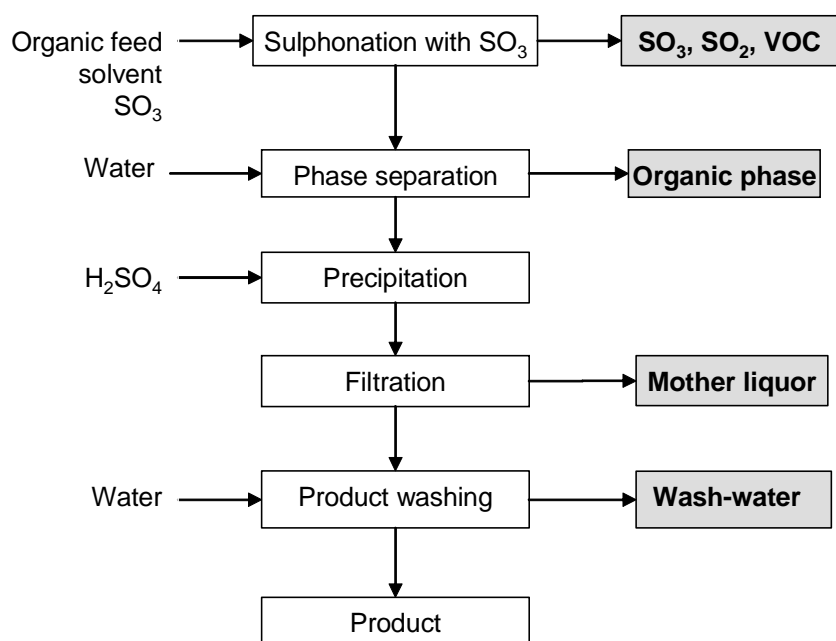

Figure 2.28: Sulphonation with SO<sub>3</sub> in liquid phase

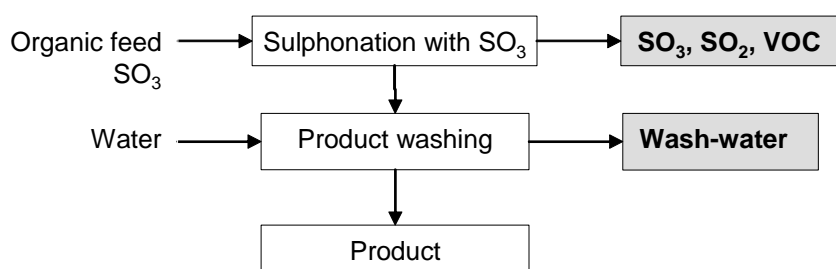

Figure 2.29: Sulphonation with SO<sub>3</sub> in gas-liquid reaction

### 2.5.14 Sulphochlorination with chlorosulphonic acid

[15, Köppke, 2000]

Sulphochlorination leads to organic sulphochlorides, which act as intermediates for a variety of fine chemicals, e.g. sulphonamides, sulphono hydrazides, sulphonic esters, sulphinic acids, sulphones, and thiophenols.

#### Chemical reaction

Sulphochlorination takes place in a two step reaction as shown:

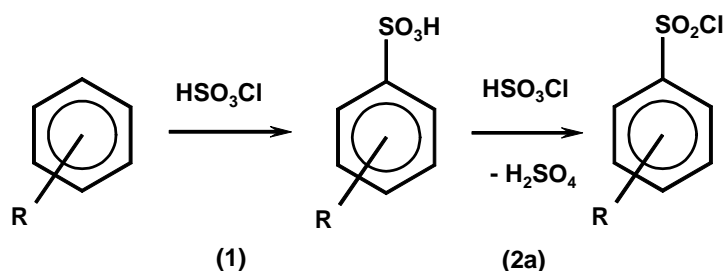
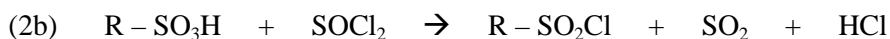

Figure 2.30: Sulphochlorination with chlorosulphonic acid

Step (1) represents a sulphonation similar to that described in Section 2.5.13. The reversible second step is a chlorination and is usually carried out with excess chlorosulphonic acid. Alternatively, thionyl chloride may be used for the second step as shown in the following equation:



Side reactions:

- formation of sulphones (e.g. 35 % in the case of chloro benzene)
- formation of isomers
- formation of other halogenation products.

#### Operations

Figure 2.31 shows a typical sequence of operations in sulphochlorination.

The chlorosulphonic acid is introduced into a cast-steel or enamelled-steel vessel and 10 - 25 mol % of the aromatic compound is stirred in at 25 – 30 °C, whereupon sulphonation of the aromatic compound and HCl formation occur. The exothermic formation of sulphonyl chloride is initiated by heating the reactants to 50 – 80 °C.

In the case of aromatic compounds that easily take up two sulphochloride groups, e.g. anisole, monochlorosulphonation is carried out with only a little more than the calculated amount of chlorosulphonic acid at a low temperature (0 °C) and in the presence of a diluent such as dichloromethane.

The temperature has to be controlled accurately to ensure the uniform release of HCl gas. Restarting the agitator after an interruption of the electricity supply is hazardous and may cause the contents of the vessel to foam over.

The product is isolated by draining the reaction mass onto water and by simultaneous cooling. The sulphonyl chloride either precipitates or separates as an organic liquid phase.

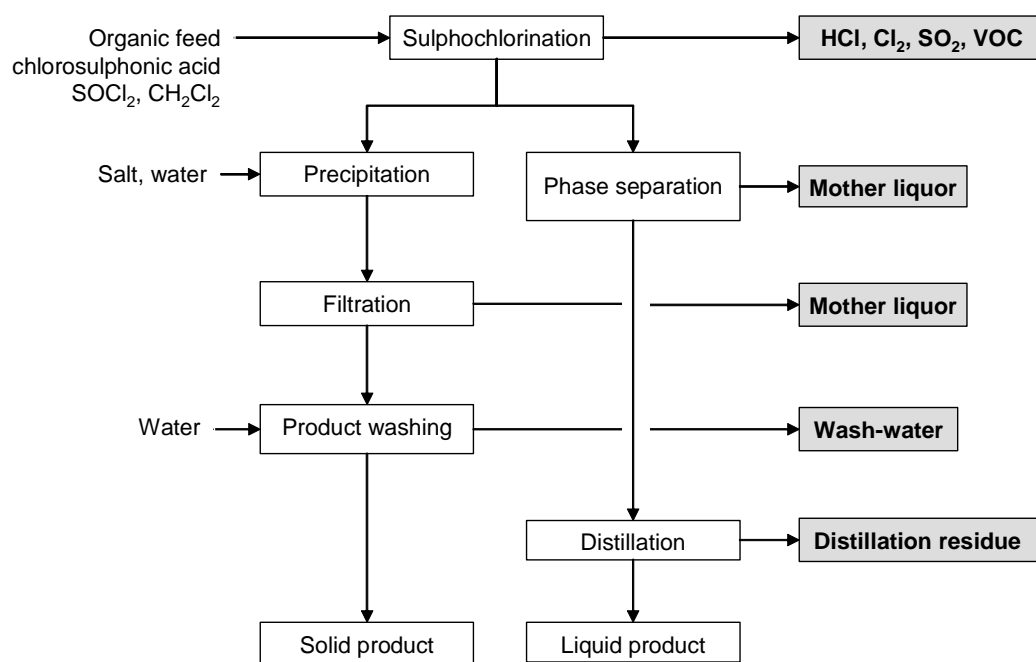

**Figure 2.31: Typical sequence of operations for sulphochlorination**  
Possible input materials (on the left) and associated waste streams (grey background)

### 2.5.15 Wittig reaction

[6, Ullmann, 2001, 9, Christ, 1999], \*003F\*

The Wittig reaction is widely used in the production of vitamins, carotenoids, pharmaceuticals and antibiotics. \*003F\* used Wittig reactions for the manufacture of fragrances but can no longer due to the difficult handling of the waste streams.

#### Chemical reaction

The Wittig reaction leads to the formation of a double bond in three steps:

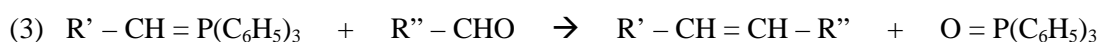
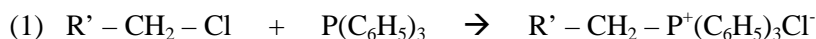

The deprotonation step (2) requires bases, e.g. alkali metal carbonate or amines. The reaction is carried out in organic solvents such as alcohols or DMF or in aqueous solutions.

High yields are achieved under mild reaction conditions. However, equimolar amounts of triphenylphosphine (TPP) must be used, and the inactive triphenylphosphine oxide (TPPO) is formed.

#### Operations

Because Wittig reactions are diverse in nature, there is no universal method of carrying them out. The production of each compound is thus considered individually, assessing the chemical, engineering, and economic factors.

### 2.5.16 Processes involving heavy metals

[1, Hunger, 2003, 6, Ullmann, 2001, 16, Winnacker and Kuechler, 1982, 51, UBA, 2004], \*018A,I\*, \*015D,I,O,B\*

Heavy metals are involved in chemical synthesis:

- if the feedstock or product contains heavy metals
- if the heavy metals are used as auxiliaries (e.g. catalysts, redox partners).

Table 2.16 gives an impression of the type of processes involving heavy metals.

	Metal	Solvents	Agent
<b>Metallisation to form chelated metals</b>			
1:1 or 1:2 complexes to form azo dyes	Chromium Nickel Cobalt Copper	Water Dilute NaOH Formic acid Formamide	Cr <sub>2</sub> O <sub>3</sub> CrCl <sub>3</sub> *6H <sub>2</sub> O K <sub>2</sub> Cr <sub>2</sub> O <sub>7</sub> *2H <sub>2</sub> O/glucose Cr formate NaKCr salicylate CoSO <sub>4</sub> *7H <sub>2</sub> O/NaNO <sub>2</sub> CuSO <sub>4</sub> *5H <sub>2</sub> O CuCl <sub>2</sub>
<b>Unit processes</b>			
Oxidations	Manganese Chromium Molybdenum		MnO <sub>2</sub> CrO <sub>3</sub>
Reductions	Zinc Copper Mercury Tin		Metal, metal chlorides
Hydrogenation	Nickel		Raney nickel
<b>Catalysts</b>			
	Nickel Copper Cobalt Manganese Palladium Platinum Ruthenium Bismuth Titanium Zirconium		Metals, metal oxides, chlorides or acetates, carbonyls

**Table 2.16: Typical processes involving heavy metals**

#### Environmental issues

Table 2.17 gives some example data of the waste streams from processes involving heavy metals.

Heavy metals are not degradable but are adsorbed to the sludge or passed through the WWTP. Heavy metal loadings in sewage sludge cause problems for disposal and, therefore, the increased costs of disposal or treatment have to be taken into account.

Catalysts containing precious metals are to be sent advantageously to recycling companies.



The usual measure applied to prevent dilution and sludge contamination/emission is the pretreatment of the concentrated waste water streams by means such as:

- ion-exchange
- precipitation/filtration
- reactive extraction.

Catalytic reduction with Raney Ni *018A,I*			
Mother liquor after filtration	Nickel	1.84 kg per batch	0.92 mg/l <sup>i</sup>
<sup>i</sup> Calculated concentration after dilution to a total effluent of 2000 m <sup>3</sup> without pretreatment			

**Table 2.17: Example data for a waste stream from processes involving heavy metals**

## 2.6 Fermentation

[2, Onken, 1996, 15, Köppke, 2000, 18, CEFIC, 2003, 25, Kruse, 2001]

The term “fermentation” means process operations that utilise a chemical change induced by a living organism or enzyme, specifically, bacteria, or the micro-organisms occurring in yeast, moulds, or fungi to produce a specified product. Most industrial microbiological processes are enhancements or modifications of metabolic reactions that micro-organisms already carry out.

Some applications of fermentation are the production or modification of the  $\beta$ -lactam antibiotics, penicillins and cephalosporins, tetracyclines, and also alkaloids and amino acids.

The industrial production of antibiotics begins with screening for antibiotic producers. A new antibiotic producer may be genetically modified to increase yields to levels acceptable for commercial development. These “Genetically Modified Organisms” (GMOs) require specific measures under Directive 90/219/EEC and Directive 90/220/EEC and are excluded from the substance definition of the IPPC Directive. They (with exceptions) have to be inactivated before they are disposed of. In practice, the manufacturing process after the fermentation stage causes the destruction of the production organism so that it is incapable of survival in the environment. If this is not achieved, then a separate deactivation step may be necessary, for example by steam sterilisation or chemical inactivation.

Fermentation technology sometimes uses pathogenic micro-organisms.

### 2.6.1 Operations

Figure 2.32 shows the typical sequences of operations for fermentations, some possible input materials and their associated waste streams.

#### Raw materials and seed stage

In the large scale fermentation of antibiotics, there are a number of stages, termed “seed stages”, leading to the final production stage. The objective of the seed stages is simply to develop an ever larger and more vigorous population of micro-organisms, with no attempt being made at this stage to produce any antibiotic. Each seed stage is used to inoculate the next, with process times for the individual seed stages usually being less than the final production stage.

The early seed stages are carried out on a laboratory scale and involve the preparation of starter cultures, which are then used to inoculate larger fermenter vessels (from some m<sup>3</sup> to 50 m<sup>3</sup> or more) containing a sterile medium.

The raw materials used as the growth medium in the fermentation process are primarily liquids stored in bulk, for example corn steep liquor, rapeseed oil and starch hydrolysate. These types of raw materials are non-volatile and there are no special precautions required for the transfer and batching into fermenter vessels. Bulk storage tanks for these materials are usually provided with secondary containment and high level alarms to prevent overfilling. Other batched solid raw materials are dispensed from bags and are dosed into the fermenter medium at low levels. The batching area is provided with an air extraction system for the protection of the operators, with the extracted air passing to a dust scrubber before being released to the air. Alternatively, the batching area is designed with closed systems, which are dust free and therefore not hazardous to the operators. Equipment and growth medium are sterilised above 120 °C for 20 minutes.

## Fermentation stage

The fermentation stage is carried out in a large stirred fermenter (from some m<sup>3</sup> to 200 m<sup>3</sup> or more) and is an aerated, batch-fed process. The batched medium is designed to support only a limited amount of further growth and is steam-sterilised within the fermenter. After sterilisation, it is inoculated with the final seed stage broth. Further sterilised nutrients are added continuously (“fed”) during the fermentation in such a way that the growth of the micro-organism is precisely controlled and the conditions made favourable for antibiotic production. The process lasts up to eight days.

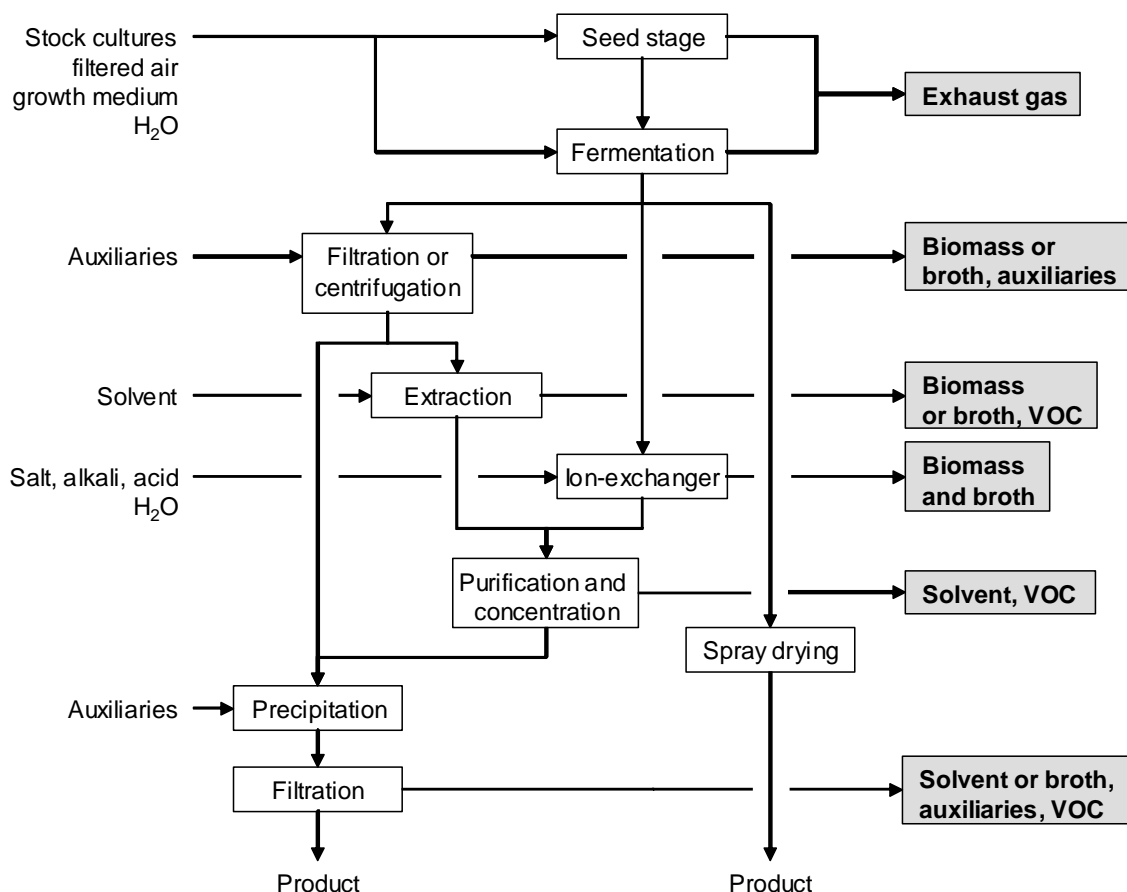

**Figure 2.32: Typical sequences of operations for fermentations and downstream work-up**  
Possible input materials (on the left) and the associated waste streams (grey background)

## Product work-up

The following work-up steps depend on the properties and location of the product. The products are obtained by separation of the biomass from the broth by:

- filtration (conventional or ultrafiltration) and extraction of the filtered broth with an organic solvent and pH adjustment (e.g. penicillin G) or extraction of the biomass with organic solvents (e.g. steroids)
- filtration (conventional or ultrafiltration) and product precipitation from the filtered broth by adjusting the pH and/or by the addition of auxiliaries (e.g. tetracyclines)
- pH adjustment and processing of the unfiltered broth over an ion-exchanger (alkaloids, amino acids)
- direct spray drying of the unfiltered broth (e.g. for feed industry purposes).

Intracellular products need an additional mechanical step of cell destruction before extraction.

Further steps can also be carried out in order to optimise the purity or concentration. The choice of methods are:

- evaporation
- ultrafiltration
- chromatography and/or ion-exchange
- reverse osmosis.

After purification, the product is obtained by conventional crystallisation and drying.

### 2.6.2 Environmental issues

Table 2.18 gives example data for waste streams from fermentations, for examples for waste waters streams from fermentations see Section 4.3.2.11. Figure 2.33 shows the applied abatement techniques. The main waste streams from fermentation processes are:

- biomass, possibly containing active pharmaceutical ingredients and possibly filtration auxiliaries
- filtered broth, possibly containing active pharmaceutical ingredients and precipitation auxiliaries
- exhaust gas from seed and fermentation stages, containing broth aerosol, possibly being malodorous
- VOC from solvent use
- large volumes of waste water streams.

If the biomass is classified as hazardous, it must be treated to reduce its activity to a level lower than 99.99 %. Inactivation is carried out, for example, by treatment with heat, with chemicals or by application of vacuum evaporators at temperatures of 85 to 90 °C. Alternatively, the hazardous biomass is incinerated, in which case the combustion device must be operated at temperatures above 1100 °C and dwell times of at least two seconds in order to achieve acceptable destruction efficiency. If the biomass is classified as non-hazardous, deactivation is generally not required, unless demanded by national regulations.

The filtered broth is usually treated in a biological WWTP.

Exhaust gases from the seed and fermentation stages contain between 1.5 and 2.5 % v/v carbon dioxide and – where no filters are used – traces of broth in an aerosol form. Often an in-vessel detector is used to automatically close the exhaust valve or to control the addition of an antifoaming agent if there is a risk of the broth splashing or foaming the outlet. Each fermenter exhaust may be backed-up by a downstream cyclone. Where appropriate, thermal oxidation is applied.

Waste stream	Properties
[15, Köppke, 2000]	
Exhaust gas	0.5 to 1 m <sup>3</sup> per m <sup>3</sup> liquid phase and per minute

**Table 2.18: Example data for the waste streams from fermentation**

Stack gas scrubbing, with hypochlorite or by using carbon adsorption or biological filters may be necessary for fermenter emissions that are malodorous. In these techniques the use of chemical scrubbers will require the blowdown of unused chemicals, which will require treatment before disposal. These systems typically have high maintenance costs. Carbon adsorption is suitable for low contaminant loads only in order to ensure acceptable carbon life, and also the high humidity of the fermenter exhaust, particularly during the sterilisation cycle can interfere with the adsorption process on the carbon. Carbon adsorbers are mechanically simple and can achieve a consistently high performance for odour removal. Biofilters are simple with relatively low capital costs, but hot fermenter exhaust arising during the sterilisation cycle will require cooling to between 25 and 35 °C.

Equipment used for crystallisation, filtration, drying and blending is vented via a chilled water scrubber to the air, with the solvent removed from the scrubber liquor by distillation. Used solvents can be recovered and re-used.

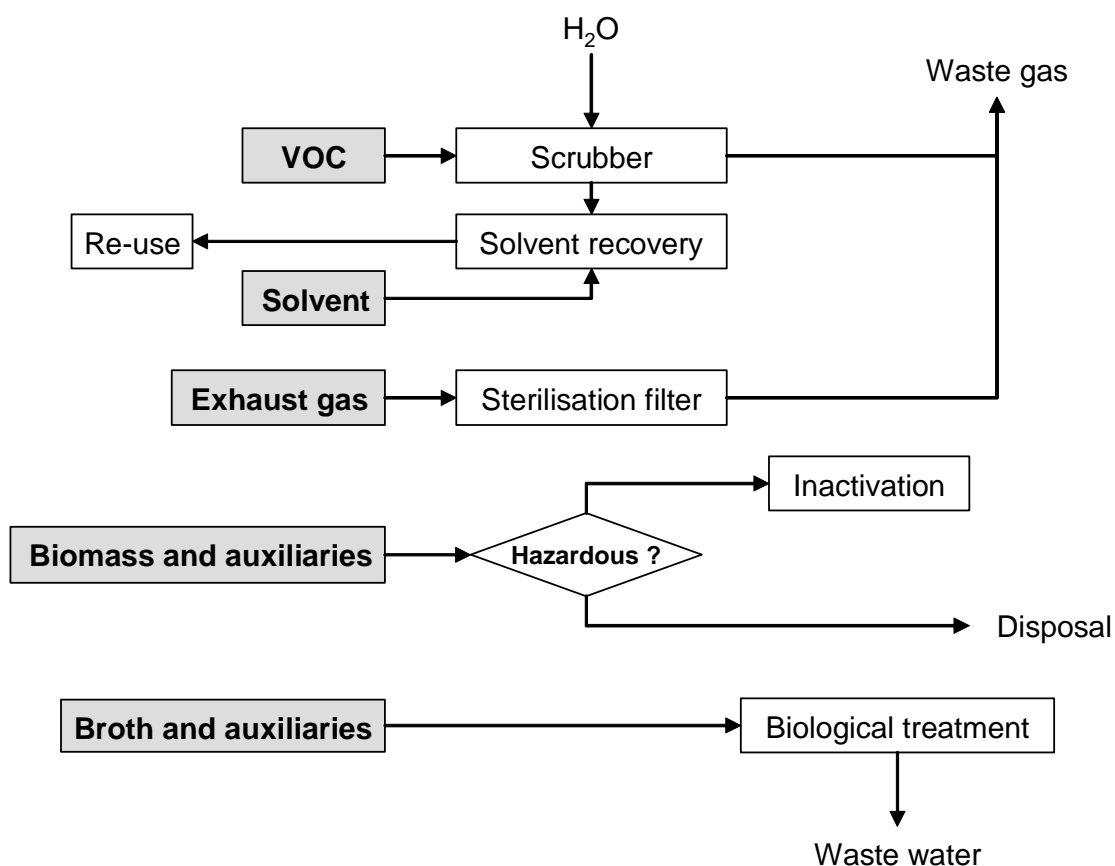

Figure 2.33: Applied abatement techniques for the waste streams from fermentation

## 2.7 Associated activities

### 2.7.1 Formulation

Many products from the chemical synthesis like, e.g. dyes/pigments, biocides/plant health products or explosives are given in formulations, mixtures, or standardised suspensions.

Such manufacturing facilities can be technically linked to the synthesis unit and are possibly linked to the same rhythm of production campaigns/batch operations and may cause emissions, such as:

- VOCs from residual solvent
- particulates from handling
- wash-water from rinsing/cleaning
- waste water streams from additional separation operations.

Table 2.19 gives some examples of waste streams from formulation activities.

Waste stream	Properties	
Exhaust gas from propellant manufacture	VOCs	*063E* *064E*
Exhaust gas from the formulation of a plant health product	Dust containing active ingredient	*058B*
Waste water streams from rinsing and CIP from standardisation of dyestuffs	0.1 % product loss	*060D,I*

**Table 2.19: Typical examples of waste streams from formulation activities**

## 2.7.2 Extraction from natural materials

[62, D1 comments, 2004], \*065A,I\*

See also Section 4.1.5.1 “Extraction from natural products with liquid CO<sub>2</sub>” and Section 4.1.5.2 “Countercurrent band extraction”.

Extraction is an important process for obtaining raw materials from natural resources. In a typical setup, the target substance (e.g. tannic acids, alkaloids, quinine salts, food additives, APIs or intermediates for APIs, additives for cosmetics) is extracted from natural materials (e.g. leaves, bark, animal organs) with a solvent and prepared for further processing by distilling off the solvent.

Extraction yields from the extraction of plant materials can vary from 10 to 0.1 % or even lower, depending on process technique, plant material quality and targeted compounds. This means that the amount of waste streams compared to the amount of end-product is considerable. To reduce the amount of waste streams, it is important to maximise the extraction yield, e.g. by using countercurrent band extraction.

To maximise re-use of waste plant materials, e.g. by composting and subsequent use as a soil conditioner, it is important to research and use extractions with non-chlorinated biodegradable solvents. Re-use of extracted fermentation broth or plant waste materials in feed industry is often not possible due to residues of harmful plant material, or residual API.

Solvent is re-used by treating plant waste materials by indirect steam heating and/or steam injection, condensation of the solvent and subsequent purification of the solvent by distillation. Waste water originating from downstream purification, e.g. with liquid-liquid extraction and phase transfer, can cause dark coloured waste water with a high load of non-biodegradable COD, due to soluble macromolecular plant materials (lignins, tannins).

Table 2.20 gives some examples of waste streams from extraction.

Waste stream	Properties	
Waste water from liquid-liquid extraction	High load of non-degradable COD (lignins, tannins)	*065A,I*
Extracted fermentation broth		
Waste plant materials		*065A,I* *006A,I*

**Table 2.20: Typical examples for waste streams from extractions**





### 3 CURRENT EMISSION AND CONSUMPTION LEVELS

The given data are based on the information provided and are derived from many different origins. A grouping according to the production spectrum was avoided by intention to prevent any assumptions in this stage.

Due to widely spread confidentiality concerns, all reference plants are named with an alias (example: \*199D,O,X\*) where the number can be used to identify the reference plant throughout this document and the letters indicate the production spectrum. A list of all reference plants is given in Table 9.1.

#### 3.1 Emissions to air

Concentration values and mass flows given in this section are derived from reference plants or other references where the individual plant was not named. The key to the comparison of concentrations and mass flows from one source is the number of the reference plant (or, in some cases, the reference to literature).

Where reference plants are named as the source, the data are usually derived from monitoring reports including background information on sampling/averaging times and also information if the sampling is representative (production situation). For interpretation of the given values, please note:

- average times vary usually from 30 to 180 minutes, in some cases the sampling time is not available
- where peaks or big variations occur within the average time, or within different samples, ranges are given in the tables.

##### 3.1.1 VOC emissions: overview

Figure 3.1 indicates the main VOC compound families and their relative share in atmospheric emissions from the Organic Fine Chemicals sector in Spain [46, Ministerio de Medio Ambiente, 2003].

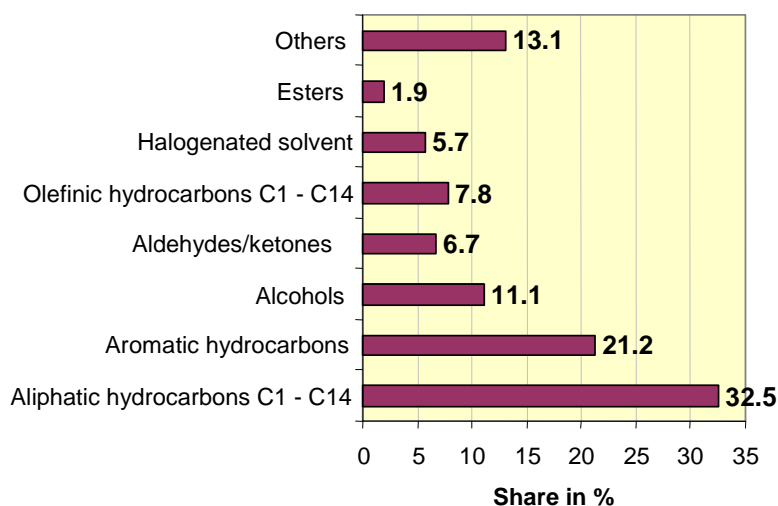

Figure 3.1: Composition of VOC emissions from the OFC sector in Spain

3.1.2 Concentration values and DeNO<sub>x</sub> efficiencies

Table 3.1 shows concentration data for the emissions to air given in contributions or reported for reference plants.

Reference	HCl	HBr	Cl <sub>2</sub>	Br <sub>2</sub>	SO <sub>2</sub>	NO <sub>x</sub>	NH <sub>3</sub>	Particulates	VOC	Dioxins /furans	DeNO <sub>x</sub> efficiency	Point source
	mg/m <sup>3</sup>								mg C/m <sup>3</sup>	ng/m <sup>3</sup>	%	
[15, Köppke, 2000]	2.9				0.6	12		5	6	0.09		Oxidiser, two scrubbers
[15, Köppke, 2000]	0.8							3.3	39			Scrubber (replaced by thermal oxidiser)
[15, Köppke, 2000]					0.16				17.5			Electrofilter, scrubber
007I A1									32 - 58			Two scrubbers
007I A2							1.1		1.2 - 4.1			Two scrubbers
007I A3							6.1		74.1			Two scrubbers
001A,I (1)	2.4		0.2		82				100			Scrubber (now replaced by thermal oxidiser)
001A,I(2)	2	0.1	0.1		0.5	164		13	1.6			Three scrubbers: HCl, HCl, NaOH/NaHSO <sub>3</sub> , oxidiser, DeNO <sub>x</sub> (urea)
008A,I(1)									2.9	0.00		Incinerator (1200 °C), DeNO <sub>x</sub> (NH <sub>3</sub> ), scrubber
008A,I(2)									3.1	0.00		Incinerator (860 °C), DeNO <sub>x</sub> (NH <sub>3</sub> ), scrubber
008A,I(3)		0.4			3.8		5.9	1.7	0.3	0.00		Incinerator, DeNO <sub>x</sub> (NH <sub>3</sub> ), scrubber
008A,I(4)									10			Scrubber (NaOH/NaHSO <sub>3</sub> ), acetic acid
008A,I(5)									4			Two scrubbers, condenser (-14 °C), cryogenic condenser (-130 to -145 °C, 200 m <sup>3</sup> /h) toluene, CH <sub>2</sub> Cl <sub>2</sub> , benzenemethylamine
010A,B,D,I,X						38			1.1	0.00		Thermal oxidiser
015D,I,O,B (1)	1	0.3			0.24			1.3	1			Two scrubbers
015D,I,O,B (2)	0.6				1.6	1.4						Scrubber, catalytic treatment
015D,I,O,B (3)	0.3				1.6	7.4	5.1	2				Scrubber, three stages
015D,I,O,B (4/1)								2.6				Scrubber
015D,I,O,B (4/2)								1.1				Scrubber
015D,I,O,B (5)								4.1				Cyclone, scrubber
016A,I (1)									108 - 184			Activated carbon adsorption
016A,I (2)									1.6 - 18.5			Activated carbon adsorption
019A,I (1)	0.37				0.08	25	0.71	1.37	0.6		96	Incinerator, DeNO <sub>x</sub> (NH <sub>3</sub> ), scrubber nitrogenous solvent loading

Reference	HCl	HBr	Cl <sub>2</sub>	Br <sub>2</sub>	SO <sub>2</sub>	NO <sub>x</sub>	NH <sub>3</sub>	Particulates	VOC	Dioxins /furans	DeNO <sub>x</sub> efficiency	Point source
	mg/m <sup>3</sup>								mg C/m <sup>3</sup>	ng/m <sup>3</sup>	%	
019A,I (2)	0.35				0.09	26	0.77	1.19	0.8	0.00		Incinerator, DeNO <sub>x</sub> (NH <sub>3</sub> ), scrubber, dioxin test
020A,I	0.66	0.11			5.04	124		3.1	0.7	0.03		Oxidiser, DeNO <sub>x</sub> (urea) scrubber high solvent loading
024A,I (1)	1						1	1				Two scrubbers
024A,I (2)	1						1	1				Scrubber
024A,I (3)	0.5						1	0.5				Four parallel scrubbers
024A,I VOC1									1688			Two scrubbers (THF, toluene, CH <sub>2</sub> Cl <sub>2</sub> , methanol, i-propanol, heptane)
024A,I VOC2									602			
024A,I VOC3									159			
024A,I VOC4									195			
037A,I	1				5	126	1	2	2	0.01		Incinerator, DeNO <sub>x</sub> (urea), scrubber
038F									35			Incinerator
044E						615						Nitrocellulose, recovery of HNO <sub>3</sub>
045E						307						Scrubber
048A,I (1)									279			Scrubber, ethanol, methanol
048A,I (2)	4											Scrubber
048A,I (2a)								3				Filter (from storage)
048A,I (3)						960						Three scrubbers: HNO <sub>3</sub> , H <sub>2</sub> O, NaOH (from nitration)
049A,I (1)					2.5				10.8 – 44.6			Three scrubbers
049A,I (1a)								0.05				Filter (from milling)
053D,X (1)					1.4	25.6			1			Oxidiser, electric filter, bag filter
053D,X (2)									1			Bag filter, from formulation
053D,X (3)									1			Bag filter, from formulation
053D,X (4)									0.7			Bag filter, from formulation
055A,I (1)									13 – 20			Catalytic oxidation, only toluene and methanol
055A,I (2)									5.6			No abatement/recovery
055A,I (4)									17.5			Thermal oxidiser
055A,I (5)						3			0.04			Catalytic oxidation (natural gas only)
055A,I (6)									42 – 57			Scrubber: NaOH or H <sub>2</sub> SO <sub>4</sub> , cryogenic condenser, smoothing filter
056X	0.2						0.09		1 - 12			Three scrubbers: H <sub>2</sub> O, H <sub>2</sub> SO <sub>4</sub> , NaOH, activated carbon adsorber 2 x 2875 kg

Reference	HCl	HBr	Cl <sub>2</sub>	Br <sub>2</sub>	SO <sub>2</sub>	NO <sub>x</sub>	NH <sub>3</sub>	Particulates	VOC	Dioxins /furans	DeNO <sub>x</sub> efficiency	Point source
	mg/m <sup>3</sup>								mg C/m <sup>3</sup>	ng/m <sup>3</sup>	%	
057F(1)	0.23	0.23						0.1	37 - 177			Scrubber: NaOH (replaced by TO)
057F(2)									124 - 228			Scrubber: NaOH (replaced by TO)
057F(3)									38 - 53			Scrubber: NaOH (replaced by TO)
058B(1)								0.3				Fabric filter (from formulation)
058B(2)								0.4				Fabric filter (from formulation)
059B,I(1)						13			5.4			Oxidiser without DeNO <sub>x</sub>
062E						480						No abatement/recovery
063E						425 - 836						Nitrocellulose, recovery of HNO <sub>3</sub> in a scrubber cascade
082A,I(1)	3 - 7.5								1.3			Oxidiser, scrubber
098E						113 - 220						Scrubber cascade: H <sub>2</sub> O and H <sub>2</sub> O <sub>2</sub>
101D,I,X(1)					12	13			9			Four central scrubbers, decentralised scrubbers
101D,I,X(2)								3				Cyclones, tube filters (from spray drying)
103A,I,X	1.5											Two scrubbers: NaOH and H <sub>2</sub> SO <sub>4</sub>
106A,I(2)	3.7		0.04			430			3	0.005		Thermal oxidiser, 980 °C, 4000 m <sup>3</sup> /h, 0.7 s dwell time, no DeNO <sub>x</sub> system, scrubber with H <sub>2</sub> O, NaOH and Na <sub>2</sub> S <sub>2</sub> O <sub>3</sub> , heat recovery (steam production)
107I,X						80 - 250						Thermal oxidiser, 1200 m <sup>3</sup> /h, SCR (NH <sub>3</sub> )
114A,I	10.4		<55			300			22.5			Thermal oxidiser 900 – 1000 °C, heat recovery, 45000 m <sup>3</sup> /h, scrubber with H <sub>2</sub> O

Table 3.1: Concentrations and DeNO<sub>x</sub> efficiencies for emissions to air for selected parameters

## 3.1.3 Mass flows

Table 3.2 shows mass flow data for the emissions to air, reported in contributions or for reference plants.

Reference	HCl	HBr	Cl <sub>2</sub>	Br <sub>2</sub>	SO <sub>2</sub>	NO <sub>x</sub>	NH <sub>3</sub>	Particulates	VOC	Dioxins/ furans	Point source
	kg/hour								kg C/ hour	µg/ hour	
007I A1									0.021 – 0.2		Two scrubbers
007I A2							0.006		0.003 -0.008		Two scrubbers
007I A3							0.001		0.35		Two scrubbers
001A,I (1)	0.024		0.002		0.82				1		Scrubber (now replaced by thermal oxidiser)
001A,I(2)	0.026				0.007	2.21		0.177	0.021		Three scrubbers: HCl, HCl, NaOH/NaHSO <sub>3</sub> , oxidiser, DeNO <sub>x</sub> (urea)
008A,I(1)									0.021	0.014	Incinerator (1200 °C), DeNO <sub>x</sub> (NH <sub>3</sub> ), scrubber
008A,I(2)									0.022	0.006	Incinerator (860 °C), DeNO <sub>x</sub> (NH <sub>3</sub> ), scrubber
008A,I(3)					0.019				0.001	0.004	Incinerator, DeNO <sub>x</sub> (NH <sub>3</sub> ), scrubber
008A,I(4)									0.005		Scrubber (NaOH/NaHSO <sub>3</sub> ), acetic acid
008A,I(5)									0.0001		Two Scrubbers, condenser (-14 °C), cryogenic condenser (-130 to -145 °C, 200 m <sup>3</sup> /h) toluene, CH <sub>2</sub> Cl <sub>2</sub> , benzenemethylamine
010A,B,D,X						0.018			0.001	0.002	Thermal oxidiser
015D,I,O,B (1)	0.000	0.006			0.005		0.002	0.025	0.019		Two scrubbers
015D,I,O,B (2)	0.013				0.034	0.03	0.064				Scrubber, catalytic treatment
015D,I,O,B (3)	0.006				0.033	0.154	0.106	0.042	0.021		Scrubber, three stages
015D,I,O,B (4/1)								0.036			Scrubber
015D,I,O,B (4/2)								0.01			Scrubber
015D,I,O,B (5)								0.146			Cyclone, scrubber
016A,I (1)									0.09 – 0.15		Activated carbon adsorption
016A,I (2)									0.001 – 0.03		Activated carbon adsorption
019A,I (1)	0.007				0.002	0.50	0.014	0.027	0.012		Incinerator, DeNO <sub>x</sub> (NH <sub>3</sub> ) scrubber nitrogenous solvent loading
019A,I (2)	0.007				0.002	0.52	0.015	0.024	0.016	0.023	Incinerator, DeNO <sub>x</sub> (NH <sub>3</sub> ), scrubber, dioxin test
020A,I	0.008	0.001			0.062	1.525		0.038	0.009		Oxidiser, DeNO <sub>x</sub> (urea) scrubber high solvent loading

Reference	HCl	HBr	Cl <sub>2</sub>	Br <sub>2</sub>	SO <sub>2</sub>	NO <sub>x</sub>	NH <sub>3</sub>	Particulates	VOC	Dioxins/ furans	Point source
	kg/hour								kg C/ hour	µg/ hour	
026E						0.002					Scrubber
037A,I	0.008				0.04	1.008	0.008	0.016	0.016	0.08	Incinerator, DeNO <sub>x</sub> (urea), scrubber
038F									0.30		Incinerator
044E						3.38					Nitrocellulose, recovery of HNO <sub>3</sub>
045E						0.018					Scrubber
048A,I (1)									0.016		Scrubber, ethanol, methanol
048A,I (2)	0.009										Scrubber
048A,I (2a)								0.01			Filter (from storage)
048A,I (3)						0.458					Three scrubbers: HNO <sub>3</sub> , H <sub>2</sub> O, NaOH (from nitration)
049A,I (1)					0.032				0.25 – 0.56		Three scrubbers
049A,I (1a)								0.2			Filter (from milling)
053D,X (1)					0.001	0.01		0.000	0.000		Oxidiser, electric filter, bag filter
053D,X (2)								0.002			Bag filter, from formulation
053D,X (3)								0.001			Bag filter, from formulation
053D,X (4)								0.003			Bag filter, from formulation
055A,I (1)									0.04		Catalytic oxidation, only toluene and methanol
055A,I (2)									0.84		No recovery/abatement
055A,I (4)									0.043		Thermal oxidiser
055A,I (5)						0.008			0.000		Catalytic oxidation (natural gas only)
055A,I (6)									0.176		Scrubber: NaOH or H <sub>2</sub> SO <sub>4</sub> , cryogenic condenser, smoothing filter
056X	0.001						0.001		0.003 – 0.040		Three scrubbers: H <sub>2</sub> O, H <sub>2</sub> SO <sub>4</sub> , NaOH, activated carbon adsorber 2 x 2875 kg
057F(1)	0.001	0.001						0.001	0.195 – 0.945		Scrubber: NaOH (replaced by thermal oxidiser)
057F(2)									0.668 – 1.229		Scrubber: NaOH (replaced by thermal oxidiser)
057F(3)									0.194 – 0.266		Scrubber: NaOH (replaced by thermal oxidiser)
058B(1)								0.004			Fabric filter (from formulation)
058B(2)								0.002			Fabric filter (from formulation)
059B,I(1)						0.045			0.018		Oxidiser without DeNO <sub>x</sub>
062E						0.069					No abatement/recovery

Reference	HCl	HBr	Cl <sub>2</sub>	Br <sub>2</sub>	SO <sub>2</sub>	NO <sub>x</sub>	NH <sub>3</sub>	Particulates	VOC	Dioxins/ furans	Point source
	kg/hour								kg C/ hour	µg/ hour	
063E						0.7 – 1.4					Nitrocellulose, recovery of HNO <sub>3</sub> in a scrubber cascade
082A,I(1)	0.03 - 0.08								0.014		Thermal oxidiser, scrubber
098E						0.87- 1.69					Scrubber cascade: H <sub>2</sub> O and H <sub>2</sub> O <sub>2</sub>
101D,I,X(1)					0.36	0.50			0.34		Four central scrubbers, decentralised scrubbers
101D,I,X(2)								0.16			Cyclones, tube filters (from spray drying)
103A,I,X	0.013										Two scrubbers: NaOH and H <sub>2</sub> SO <sub>4</sub>
106A,I(2)	0.015		0.000			1.72			0.012		Thermal oxidiser, 980 °C, 4000 m <sup>3</sup> /h, 0.7 s dwell time, no DeNO <sub>x</sub> system, scrubber with H <sub>2</sub> O, NaOH and Na <sub>2</sub> S <sub>2</sub> O <sub>3</sub> , heat recovery (steam production)
107I,X						0.1 – 0.3					Thermal oxidiser, 1200 m <sup>3</sup> /h, SCR (NH <sub>3</sub> )
114A,I	0.46		<2.5			13.4			1		Thermal oxidiser 900 – 1000 °C, heat recovery, 45000 m <sup>3</sup> /h, scrubber with H <sub>2</sub> O

Table 3.2: Mass flows values for the emissions from point sources

## 3.2 Waste water

The levels given in the following data collection are usually based on daily average values and data sets of a few months up to one year. Elimination rates are obtained from input and output levels to and from the biological WWTP. Where data were not provided, table fields were left empty.

### 3.2.1 Reported COD and BOD<sub>5</sub> emissions and elimination efficiencies

Table 3.3 shows the reported COD and BOD<sub>5</sub> emissions and the related elimination efficiencies. Most data refer to the treatment of the total effluent biological WWTP, but in individual cases the overall COD elimination may be higher due to pretreatment steps. Such or similar situations are described under “Additional treatments, remarks”.

Plant	COD		COD elim.	BOD <sub>5</sub>		BOD <sub>5</sub> elim.	Volume flow	Additional treatments, remarks
	Before treatment	After treatment		Before treatment	After treatment			
	mg/l		%	mg/l		%	m <sup>3</sup> /d	
002A	25000	1500	94				250	Subsequent treatment in municipal plant
003F	3500	130	96				300	Direct discharge to river
004D,O	5000	250	95				150	Nano-filtration for certain optical brighteners, wet oxidation plant, additional municipal plant in planning
007I	4740						350 (peak)	Treatment in municipal WWTP
008A,I (2000)	1600	100	94	1100	7	99.4	3800	
008A,I (2003)	2500	89	97	1900	5	99.8	3700	
009A,B,D (2000)	160	12	93		1		11000	Central activated carbon facility with on-site thermal regeneration for waste water streams containing chlorinated nitroaromatics. Overall COD elimination: 96 %, overall AOX elimination 99 %
009A,B,D (2002)	292	12	96		1		4500	
010A,B,D,I,X (2000)	2580	190	93	1350	6	99.6	41000	Stripping of waste water streams from production of C1-CHC, solvent recovery from waste water streams by distillation, Hg removal from waste water streams, precipitation of heavy metals, distillation of waste water streams for solvent recovery, Ni catalyst recycling, since 2001 2-stage WWTP with basins and tower biology. The volume flow includes groundwater treatment.
010A,B,D,I,X (2003)	2892	184	94	1521	12	99	47500	



Plant	COD		COD elim.	BOD <sub>5</sub>		BOD <sub>5</sub> elim.	Volume flow	Additional treatments, remarks
	Before treatment	After treatment		Before treatment	After treatment			
	mg/l		%	mg/l		%	m <sup>3</sup> /d	
011X (2000)	4750	220	95	2430	18	99.3	1300	Distillation of waste water streams, e.g. from production of light stabilisers, removal of tin-organic compounds from waste water streams
011X (2003)		360			8		1300	
012X (2000)	1750	68	96	820	9	98.9	4300	Wet oxidation with H <sub>2</sub> O <sub>2</sub> of waste water streams from fungicide production, oxidation of waste water streams containing NaS, concentration of waste water streams containing sulphuric acid, precipitation of Ni
012X (2002)	600	41	93		3.4		8260	
013A,V,X (2000)	1740	98	94	890	5	99.4	5750	Stripping of waste water streams with high concentrations of purgeable AOX and solvents, removal of Ni and Hg
013A,V,X (2003)	1084	51	95	612	8	98.7	5180	
014V,I (2000)	3300	167	95	1400	7	99.5	8000	Pretreatment of waste water streams from vitamin production in a low pressure wet oxidation plant with 96 % elimination for COD (AOX: 95 %). Concentration by evaporation and incineration of the residues. Removal and recycling of solvents (especially dioxane), extraction from waste water streams, pretreatment by hydrolysis, removal of Zn from exhaust gas (electro filter) before scrubbing
014V,I (2003)	2660	133	95	1130	7	99.7	8000	
015D,I,O,B (2000)	1000	250	75	370	6	98.4	11000	Municipal waste water 50 %, central high pressure wet oxidation for waste water streams containing refractory TOC loads (10 % of the volume, 50 % of the total TOC load) with overall TOC elimination of 89 %. Adsorption/extraction of waste water streams from the production of antimicrobica.
015D,I,O,B (2003)	930	220	77		8		11000	Central nanofiltration for waste water stream from the production of dyes, optical brighteners and intermediates. Central extraction of waste water streams containing aromatic sulphonates. Stripping of NH <sub>3</sub> , precipitation of Cu.
016A,I (1998/1999)	2025	105	95				1500	Data from 1998/99, before plant extension and additional pretreatment

Plant	COD		COD elim.	BOD <sub>5</sub>		BOD <sub>5</sub> elim.	Volume flow	Additional treatments, remarks
	Before treatment	After treatment		Before treatment	After treatment			
	mg/l		%	mg/l		%	m <sup>3</sup> /d	
016A,I (2001)			97				1500	Pretreatment of low degradable streams by adsorption: 97.2 % TOC elimination in 2001, treatment including two biological steps, chemical precipitation and active carbon adsorption
016A,I (3)	1340	40	97				1500	Values 2003
017A,I	9000	390	96			99.6	500	Average Jan – Sep 2003 Segregation and incineration of particular waste water streams
018A,I	3039	141	95				350	Average Jan – Sep 2003 Segregation and incineration of particular waste water streams
023A,I	5115	260	95	3491	16	99.8	1000	Incineration of waste water streams with bioeliminability <80 %
024A,I			100			100		Incineration of all waste waters
026E	2600	182	93		2		<b>20</b>	Recycling of all spent acids, re-use of wash-water, very low volume flow
043A,I	2290	189	92				2400	Stripping of CHCs
044E	200						1100	Recycling of all spent acids, co-treatment of waste waters in municipal WWTP
045E	100		100			100	60	Recycling of all spent acids, evaporation of waste water streams in solar ponds (without energy consumption)
055A,I (2002)	729		94				2000	Stripping, activated carbon adsorption, segregation and disposal
086A,I	5734	192	96.5	3071	8.3	99.8	975	Average Jan – Jun 2004
089A,I		18	96					Segregation and disposal of mother liquors with bioeliminability <90 %, activated carbon adsorption after biological WWTP for AOX peaks
090A,I,X		79	95					
103A,I,X	1310		83	765			60	Two days buffer before discharge to municipal sewer

Table 3.3: COD and BOD<sub>5</sub> emissions, volume flows and elimination efficiencies

### 3.2.2 Reported emissions for inorganic parameters and related elimination efficiencies

Table 3.4 shows the reported emissions for inorganic parameters and the related elimination efficiencies.

Plant	NH <sub>4</sub> -N		NH <sub>4</sub> -N elimination	Total N		Total N elimination	Inorganic N		Inorg. N elimination	Total P		Total P elimination
	Before treatment	After treatment		Before treatment	After treatment		Before treatment	After treatment		Before treatment	After treatment	
	mg/l		%	mg/l		%	mg/l		%	mg/l		%
006A,I												
008A,I (2000)	30	2	93.3	40	25	37.5		20		4.2	0.5	88
008A,I (2003)	47	0.1	99.8	80	22	75.3		16		4.5	0.3	96.4
009A,B,D (2000)	4.2	0.9	78.6				50	28	44		0.13	
009A,B,D (2002)		0.7						14			0.2	
010A,B,D,I,X (2000)							100	9	91	48	0.8	98.3
010A,B,D,I,X (2003)							51	34	33	44	0.9	98
011X (2000)							88	14.7	83.3	16	1.5	90.6
011X (2003)								17			0.55	
012X (2000)							35	3.7	89.4	5	0.7	86
012X (2002)		1.5					11.2	7	37.5	3.5	0.6	83
013A,V,X (2000)							45	2.7	94	7	0.9	87
013A,V,X (2003)	22	1.2	94.5				43	2.7	93.7	6.7	0.8	88
014V,I (2000)	100	5	95	155	23	85.2	100	7	93	5	0.9	82
014V,I (2003)	80	3	96	130	17	87	110	8	93	4	0.6	85
015D,I,O,B (2000)	152	13	91.5				153	18	88.2	7	1.1	84.3
015D,I,O,B		12						19		3.6	1.1	70

Plant	NH <sub>4</sub> -N		NH <sub>4</sub> -N elimination	Total N		Total N elimination	Inorganic N		Inorg. N elimination	Total P		Total P elimination
	Before treatment	After treatment		Before treatment	After treatment		Before treatment	After treatment		Before treatment	After treatment	
	mg/l		%	mg/l		%	mg/l		%	mg/l		%
(2003)												
016A,I1				29	9.5	67				28	1.2	96
016A,I2						80						98
017A,I						85						
018A,I						75						
023A,I				148	48	68						
026E <sup>1</sup>		0.8		5458	465	91					0.23	
043A,I	42											
047B					20			12				
055A,I				6.4						6.8		
081A,I					25			22				
086A,I	135.8	7.8	93.3	254	11.3	95.5				16.9	10.8	35.2
089A,I		0.05			10						0.6	
090A,I		0.08			28.7						0.7	
096A,I					1			2			0.3	
097X					35			23			0.8	
100A,I		33.8						50.4				
103A,I,X	3.9						10.7			14.2		

<sup>1</sup> Volume flow of 20 m<sup>3</sup>/d

**Table 3.4: Emission data for inorganic parameters and elimination efficiencies**

### 3.2.3 Reported emission values for AOX and toxicities

Table 3.5 shows the reported AOX emissions and the related elimination efficiencies, and toxicities.

Plant	AOX		AOX elim.	Toxicity				
	Before treatment	After treatment		After treatment				
	mg/l		%	LID <sub>F</sub>	LID <sub>D</sub>	LID <sub>A</sub>	LID <sub>L</sub>	LID <sub>EU</sub>
008A,I (2000)	0.95	0.81		2	1	1 – 8	1 – 8	1.5
008A,I (2003)	0.57	0.18		2	2	2	2 – 12	1.5
009A,B,D (2000)	1.1	0.16	85.5	1	2	1	2	
009A,B,D (2002)	1.8	0.15	91.6	2				
010A,B,D,I,X (2000)	14	0.9	93.6	2	1	3	8	
010A,B,D,I,X (2003)	3.8	0.68	82	2	1	2		
011X (2000)	1.5	0.25	83.3	3	5	12	8	
011X (2003)		0.14		3	4	16	8	
012X (2000)		0.3		2				
012X (2003)		0.34		2	4	1	4	
013A,V,X		0.4						
014V,I (2000)	1.1	0.13	88	2	1 – 2	1	1	1.5
014V,I (2003)	0.9	0.11	87					
015D,I,O,B (2000)	8.5	1.7	80	2	1 – 4	1 – 32	4 – 32	1.5
015D,I,O,B (2003)	6.3	1.5	77					
023A,I		5						
040A,B,I (1996) <sup>i</sup>				1.0	2.0	1.0	2.9	
055A,I	1.53		76					
089A,I		0.06		1	1	2	2	1.5
090A,I,X		0.08		1	2	2 – 3	2	1.5
				EC <sub>50, F</sub>	EC <sub>50, D</sub>	EC <sub>50, A</sub>	EC <sub>50, L</sub>	EC <sub>50, EU</sub>
				Expressed as vol-%				
037A,I				100	100	100	0.8 – 45	
038F				100	100	16 – 25	45	
115A,I					100		45	
016A,I(1)							38	

<sup>i</sup> For the development of the levels in \*040A,B,I\* over some years, see Section 4.3.8.18.

**Table 3.5: Emission values for AOX and toxicities**

### 3.3 Waste

[46, Ministerio de Medio Ambiente, 2003]

Table 3.6 shows the waste generated by 20 companies in Catalonia, Spain, producing organic fine chemicals in 2001. The 120000 metric tonnes had the following destinies:

- utilisation (80.9 %)
- incineration (9.4 %)
- controlled deposition (6.0 %)
- physico-chemical treatment (3.5 %).

Generated waste	Share in %
Non halogenated solvents	42.5
Non halogenated organic liquids	39.4
Sludge from effluent treatment	7.6
Salt solutions	3.9
Halogenated solvents	2.0
Special wastes	1.9
Wash-water	1.5
“Banal” waste	1.3

**Table 3.6: Waste generated by 20 OFC companies in Catalonia, Spain**

## 4 TECHNIQUES TO CONSIDER IN THE DETERMINATION OF BAT

This chapter sets out techniques considered generally to have potential for achieving a high level of environmental protection in the industries within the scope of the document. Management systems, process-integrated techniques and end-of-pipe measures are included, but a certain amount of overlap exists between these three when seeking the optimum results.

Prevention, control, minimisation and re-cycling procedures are considered as well as the re-use of materials and energy

Techniques may be presented singly or as combinations to achieve the objectives of IPPC. Annex IV of the Directive lists a number of general considerations to be taken into account when determining BAT and techniques within this chapter will address one or more of these considerations. As far as possible, a standard structure is used to outline each technique, to enable comparison of techniques and an objective assessment against the definition of BAT given in the Directive.

The content of this chapter is not an exhaustive list of techniques and others may exist or be developed which may be equally valid within the framework of BAT.

Generally a standard structure is used to outline each technique, as shown in Table 4.1.

Type of information considered	Type of information included
Description	Technical description of the technique
Achieved environmental benefits	Main environmental impact(s) to be addressed by the technique (process or abatement), including emission values achieved and efficiency performance. Environmental benefits of the technique in comparison with others
Operational data	Performance data on emissions/wastes and consumption (raw materials, water and energy). Any other useful information on how to operate, maintain and control the technique, including safety aspects, operability constraints of the technique, output quality, etc.
Cross-media effects	Any side effects and disadvantages caused by implementation of the technique. Details on the environmental problems of the technique in comparison with others
Applicability	Consideration of the factors involved in applying and retrofitting the technique (e.g. space availability, process specific). Where no information about restrictions is provided, the technique is described as "Generally applicable"
Economics	Information on costs (investment and operation) and any possible savings (e.g. reduced raw material consumption, waste charges) also as related to the capacity of the technique
Driving force for implementation	Reasons for implementation of the technique (e.g. other legislation, improvement in production quality)
References to literature and example plants	Literature for more detailed information on the technique and reference to plants where the technique is reported to be used

**Table 4.1: Information breakdown for each technique described in this chapter**

## 4.1 Prevention of environmental impact

### 4.1.1 Green chemistry

#### Description

Concerning the production of chemicals, the principle of green chemistry is to promote the use of alternative synthetic routes and alternative reaction conditions to existing less-environmentally friendly processes; i.e. by:

- improving process designs to maximise the incorporation of all the input materials used into the final product
- usage of substances that possess little or no toxicity to human health and the environment. Substances should be chosen in order to minimise the potential for accidents, releases, explosions and fires
- avoiding the use of auxiliary substances (e.g. solvents, separation agents, etc.) wherever possible
- minimising energy requirements, in recognition of the associated environmental and economic impacts. Reactions at ambient temperatures and pressures should be preferred
- using renewable feedstock rather than depleting, wherever technically and economically practicable
- avoiding unnecessary derivatisation (e.g. blocking or protection groups) wherever possible
- applying catalytic reagents, which are typically superior to stoichiometric reagents.

#### Achieved environmental benefits

Minimisation of the environmental impact of a process, at an early design stage.

#### Cross-media effects

*None believed likely.*

#### Operational data

*No information provided.*

#### Applicability

Mostly applicable to new processes, but often a compromise has to be found or one of the aspects has to be favoured more than another. As an example: phosgene can be a very efficient reactant in organic chemistry but on the other hand, it is quite toxic.

Where API manufacture on a site requires the observance of the rules of current Good Manufacturing Practice (cGMP) or approval by the Federal Drug Administration (FDA), process modifications can be only carried out fulfilling the required variation procedure. This represents a serious obstacle for the redesign of existing processes. Similar restrictions exist, for example, for the manufacture of explosives.

Another option for the prevention of environmental impacts is the use of input materials of higher purity [99, D2 comments, 2005].



### **Economics**

Prevention of problems is expected to be more cost effective than later process reviews or end-of-pipe techniques.

### **Driving force for implementation**

Optimised process design, improved safety and working conditions.

### **References to literature and example plants**

[10, Anastas, 1996, 46, Ministerio de Medio Ambiente, 2003]

See also, ACS Green Chemistry Institute (<http://www.chemistry.org>) and EPA Green Chemistry (<http://www.epa.gov/greenchemistry/index.html>)

## 4.1.2 Integration of EHS considerations into process development

### Description

The likelihood of successful prevention and minimisation of the environmental impact of a process increases if Environment, Health and Safety (EHS) are considered early in the development chain. The assessment process is based on prevention, minimisation and making harmless and aims to design out environmental issues and to provide an auditable trail for environmental issues. Table 4.2 gives an overview to the tools of such an assessment.

Initial assessment and prioritisation	Paper assessment of EHS issues
	Listed materials
	Problem materials
	Problem technologies
<b>Nomination of the target compound</b>	
Prevent	Attempt to remove all major EHS issues
	Design for environment inherent EHS
<b>Synthesis freeze</b>	
Minimise	Focus on efficiency
<b>Process freeze</b>	
Make harmless	Manage residual EHS issues, define treatment processes
	Site restrictions
	Legal requirements
	Available disposal options
<b>Technology transfer on-site</b>	
Transfer information from development	Ensure knowledge of EHS issues associated with the process is transferred to manufacture

**Table 4.2: Integration of environmental, health and safety aspects in process development**

### Achieved environmental benefits

Possibility to prevent, minimise and make harmless environmental issues.

### Cross-media effects

*None believed likely.*

**Operational data**

*No information provided.*

**Applicability**

Generally applicable.

**Economics**

Consumes time and manpower but minimises costs for managing residual environmental issues.

**Driving force for implementation**

Prevention of environmental, health and safety issues at an early stage.

**References to literature and example plants**

[91, Serr, 2004], \*016A,I\*

### 4.1.3 Example for a solvent selection guide

#### Description

Solvent selection is a key part of process development. Because of the volumes used, solvents can often result in the biggest environmental, health and safety impact of a process. There are a number of methodologies to aid in the search for environmentally benign solvent systems. Table 4.3 shows an example for a solvent selection guide. The table assigns a score from 1 to 10 for each solvent under the respective categories with 10 being of concern and 1 suggesting few issues. The table is further simplified by using colour coding with scores between 1 and 3 being green, 4 to 7 yellow and 8 to 10 red. Categories are further explained in Table 4.4.

#### Achieved environmental benefits

Prevention of big environmental issues at an early development stage.

#### Cross-media effects

*None believed likely.*

#### Operational data

*No information provided.*

#### Applicability

The applicability depends on the particular case. The solvent has to fulfil a certain task, which often restricts the choice.

More information about classification and selection of solvents can be found in [99, D2 comments, 2005]:

- <http://ecb.jrc.it/existing-chemicals/>
- Curzons, A.D., Constable, D.C., Cunningham, V.L. (1999). Solvent selection guide: a guide to the integration of environmental, health and safety criteria into the selection of solvents. Clean Products and Processes. 82-90.
- Sherman, J., Chin, B., Huibers, P.D.T., Garcia-Valls, R., Hutton, T.A. (1998). Solvent replacement for green processing. Environmental Health Perspectives, Vol 106, Supplement 1. February 1998.
- Joback, K.G. (1994) Solvent Substitution for Pollution Prevention. AIChE Symposium Series. Vol 303, Pt 90, pp 98-104.

#### Economics

The possibility to prevent an environmental issue early in the process development can reduce costs for recovery/abatement.

#### Driving force for implementation

Prevention of environmental issues.

#### References to literature and example plants

\*016A,I\*

Substance			Safety		Health	Environment					
	Name	CAS No	Flammability	Static	Health	Impact on air	VOC potential	Impact in water	Potential biotreatment plant load	Recycle	Incineration
Acids:	Methane sulphonic acid <sup>1</sup>	75-75-2	1	1	1	1	1	7	4	6	8
	Propionic acid	79-09-4	3	1	4	7	1	1	5	6	6
	Acetic acid (glacial)	64-19-7	3	1	8	6	3	1	5	6	6
	Formic acid	64-18-6	3	1	10	4	5	1	5	6	7
Alcohols:	Isoamyl alcohol	123-51-3	3	1	2	1	1	2	4	5	3
	1-Pentanol	71-41-0	7	1	1	2	1	1	4	5	3
	Isobutanol	78-83-1	7	1	3	2	2	1	5	7	3
	n-Butanol	71-36-3	7	1	4	3	2	1	5	6	3
	Isopropanol	67-63-0	7	1	3	1	5	1	6	5	5
	IMS/Ethanol	64-17-5	7	1	2	2	5	1	7	5	5
	Methanol	67-56-1	7	1	5	3	6	1	7	4	5
	t-Butanol	75-65-0	7	1	6	2	4	3	7	5	5
2-Methoxy ethanol <sup>2</sup>	109-86-4	3	1	10	8	2	2	5	6	5	
Alkanes:	Isopar G	90622-57-4	3	10	1	1	1	10	3	10	1
	n-Heptane	142-82-5	7	10	3	1	5	8	5	2	1
	Isooctane	540-84-1	7	10	3	1	5	10	5	2	1
	Cyclohexane	110-82-7	7	10	6	1	6	9	5	2	1
	Solvent 30 (assumed benzene free)	64742-49-0	7	10	2	1	4	10	4	10	1
	Isohexane	107-83-5	7	10	6	1	8	10	6	1	1
Aromatics:	Xylene	1330-20-7	7	10	2	4	2	7	3	4	1
	Toluene	108-88-3	7	10	5	2	4	7	4	4	1
Basics:	Triethylamine	121-44-8	7	1	10	6	6	5	6	5	4
	Pyridine	110-86-1	7	1	9	10	3	4	7	6	6
Chlorinated:	Chlorobenzene	108-90-7	7	1	6	4	2	9	2	4	5
	Methylene chloride <sup>3</sup>	75-09-2	1	1	9	9	10	6	5	2	8
Esters	n-Butyl acetate	123-86-4	7	1	2	3	2	3	3	4	3

Substance			Safety		Health	Environment					
	Name	CAS No	Flammability	Static	Health	Impact on air	VOC potential	Impact in water	Potential biotreatment plant load	Recycle	Incineration
	Isopropyl acetate	108-21-4	7	1	4	2	5	2	5	4	3
	Ethyl acetate	141-78-6	7	1	5	2	6	2	5	5	4
Ethers:	Diphenyl ether	101-84-8	1	1	1	4	1	8	3	4	2
	Anisole	100-66-3	3	10	2	1	1	4	3	6	2
	Tetrahydrofuran	109-99-9	7	1	8	1	7	3	7	6	5
	Diglyme	111-96-6	3	1	10	7	1	5	5	10	5
	1,2 Dimethoxyethane	110-71-4	3	1	10	3	6	5	7	8	5
	MTBE	1634-04-4	7	1	9	2	8	7	7	5	3
	1,4-Dioxane	123-91-1	7	10	9	3	4	4	6	9	5
	Diethyl ether	60-29-7	10	10	7	3	10	4	7	6	3
Fluorinated:	Trifluorotoluene	98-08-8	7	10	4	6	5	8	3	4	6
Ketones:	MIBK	108-10-1	7	1	6	1	3	2	4	7	3
	Methylethyl ketone	78-93-3	7	1	7	4	6	1	6	7	4
	Acetone	67-64-1	7	1	6	3	8	1	8	4	5
Polar aprotic:	DMSO <sup>4</sup>	67-66-5	1	1	1	1	1	3	5	6	6
	N-Methyl pyrrolidone	872-50-4	1	1	1	1	1	1	6	6	6
	Sulfolane	126-33-0	1	1	1	3	1	4	5	6	7
	Dimethyl acetamide	127-19-5	3	1	4	7	1	2	6	6	6
	DMF	68-12-2	3	1	9	7	1	1	5	6	6
	Acetonitrile	75-05-8	7	1	8	2	6	4	8	5	6

<sup>1</sup> The “impact in water” score for methane sulphonic acid has been based on limited data.

<sup>2</sup> 2-methoxy ethanol is on the Swedish Restricted Chemicals List. The comment is that “the goal is to phase out this substance”. Therefore, use in Sweden will need careful consideration.

<sup>3</sup> In Sweden, methylene chloride is essentially banned for use in processes.

<sup>4</sup> DMSO can decompose to form dimethyl sulphide. This an extremely malodorous substance and requires high levels of abatement to prevent odour being an issue. Also under the UK regulations, organic sulphides have benchmark release levels of 2 mg/m<sup>3</sup>. Care should be taken to assess emission levels of dimethyl sulphide when using DMSO.

Table 4.3: Solvent selection guide from \*016A,I

<b>Safety</b> <sup>1</sup>	Flammability	Assessed according to the UK National Fire Protection Association's (NFPA) scoring system.
	Static	A score of either 1 or 10, depending on whether the material can accumulate an electrostatic charge. (It is important to note that electrical resistivity will depend on the source, purity, potential contaminants and any other material dissolved in the solvent. Care is needed when applying such data. If there is any doubt, a sample should be tested.)
<b>Health</b>		Rating is primarily based on the exposure potential. This is estimated by calculating the vapour hazard rating: saturated concentration at 20 °C divided by the Occupational Exposure Limit (OEL).
<b>Environment</b> <sup>2</sup>	Impact in air	The category is made up of five separate elements. These are the UK Long Term Environmental Assessment Level (EAL), VOC Directive impact, rate of photolysis, Photochemical Ozone Creation Potential (POCP) and odour potential.
	VOC potential	Assesses the magnitude of likely emissions based on the vapour pressure of the solvent at 20 °C.
	Impact in water	Judged on the criteria of toxicity, biodegradability and the likelihood of bioaccumulation (as estimated from octanol/water partition coefficient).  If the process is unlikely to contain any streams suitable for ultimate release to water, this category could be ignored. However, the category is still relevant for accidental releases from the processes.
	Potential biotreatment plant load	Estimates the effect of a solvent on the operation of a biological treatment facility. It assesses impact due to load (both carbon and nitrogen loading), the effects of air stripping from the plant and, in the instances of processes where water is present, the increased effect of solvents due to their water solubility.  If the process is unlikely to contain any streams suitable for biotreatment, this category could be ignored.
	Recycle	Assesses the potential ease of recovery of the solvent. The elements that are used to assess this are the number of other solvents in the guide with a boiling point within 10 °C, the boiling point, the risk of peroxide formation on distillation and the water solubility (affecting potential loss in aqueous streams).
	Incineration	Key properties of solvents for incineration are heat of combustion, aqueous solubility, and halogen, nitrogen and sulphur content. Some of these problems can be minimised by blending with other waste solvents by the incinerator operator. However, this has not been taken into account in the scoring system.
<p><sup>1</sup> The safety considerations in the guide are limited to operational hazards, i.e. fire and explosion hazards.</p> <p><sup>2</sup> Many of the subcategories in this section assume that the solvents are used in an aqueous process. It is important to use judgement when applying the scores to solvent only processes.</p>		

**Table 4.4: Properties that were considered and scored in the solvent selection guide from \*016A,I\***

## 4.1.4 Examples for alternative synthesis and reaction conditions

### 4.1.4.1 Sulphonation with SO<sub>3</sub> in gas-liquid reaction

#### Description

Sulphonation of fatty alcoholates and ethoxylates can be carried out with SO<sub>3</sub> in a gas-liquid reaction. For a description of this please see Section 2.5.13.

#### Achieved environmental benefits

- no aqueous mother liquors
- no wash-waters from product washing
- waste waters only arise from the alkaline scrubbing of exhaust gas, and >95 % of the scrubbing liquid is recycled.

#### Cross-media effects

*None believed likely.*

#### Operational data

*No information provided.*

#### Applicability

The applicability depends on the particular case. The production of each compound is thus considered individually, assessing the chemical, engineering, and economic factors.

#### Economics

No data provided, but it can be presumed that economic advantages were the driving force for implementation.

#### Driving force for implementation

Process optimisation, economics.

#### References to literature and example plants

[51, UBA, 2004], \*061X\*



#### 4.1.4.2 Dry acetylation of a naphthylamine sulphonic acid

##### Description

Instead of acetylation in an aqueous medium and salting out the product with ammonium sulphate, 2-naphthylamine-8-sulphonic acid can be acetylated in acetic anhydride without the generation of waste water streams. The generated acetic acid can be recovered easily and recycled into other processes.

##### Achieved environmental benefits

- waste water streams: - 100 %
- salt for salting out: - 100 %
- recovery of 270 kg acetic acid per 1000 kg product.

##### Cross-media effects

Shift from waste water to waste gas.

##### Operational data

Flat bottomed vessel with stirring equipment and steam heating is required.

##### Applicability

Generally not restricted to acetylations, but the applicability depends on the particular case. The production of each compound is thus considered individually, assessing the chemical, engineering, and economic factors.

##### Economics

No comparison of the conventional and the new process was possible due to the lack of data, but economic advantages are presumed to be the driving force.

##### Driving force for implementation

Process optimisation, economics.

##### References to literature and example plants

[9, Christ, 1999], \*010A,B,D,I,X\*

## 4.1.4.3 Recycling instead of treatment/disposal of TPPO

## Description

TPPO is a residue created in Wittig processes in stoichiometric amounts (for an example see Table 4.5). TPPO is not easily degradable and phosphorus may be a critical parameter for a WWTP. The described treatment steps for the disposal of TPPO still lead to the formation of solid residues, and the created  $P_2O_5$  may have poisoning effects on DeNO<sub>x</sub> catalysts and cause clogging of filters.

Processing of a C <sub>15</sub> unit for retinoid synthesis [6, Ullmann, 2001]			
300 kg starting material			
Solid residue	TPPO	380 kg	

Table 4.5: Example for the creation of TPPO from a Wittig process

Instead of treatment and disposal (Figure 4.1), TPPO can be recycled by conversion to TPP according to the scheme given in Figure 4.2 and re-used for further processing.

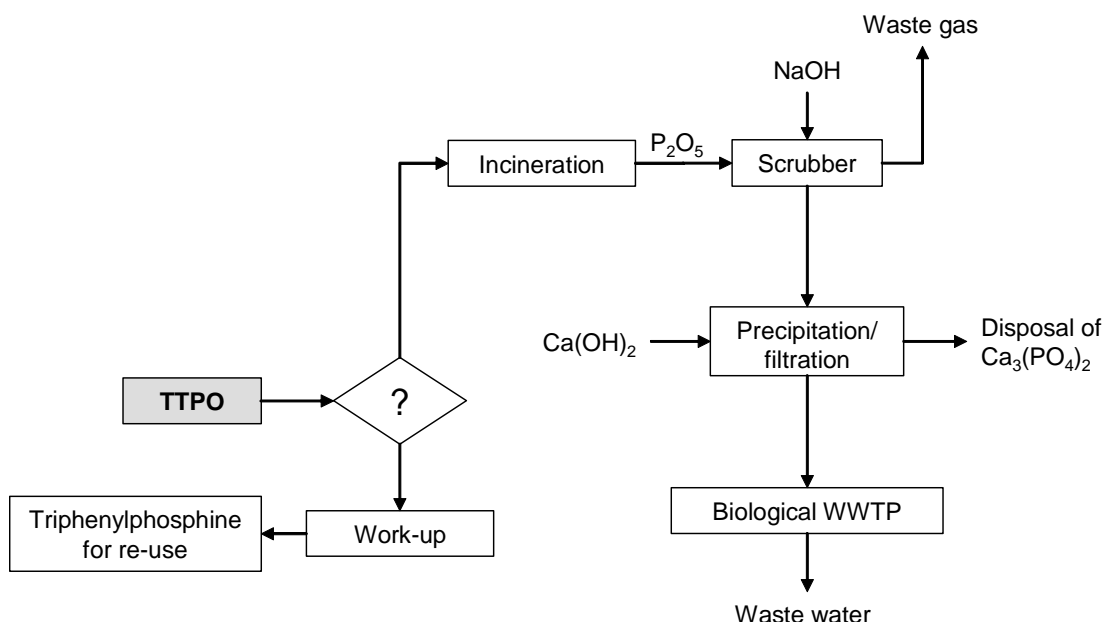

Figure 4.1: Treatment steps for the disposal of TPPO

## Achieved environmental benefits

Figure 4.3 compares the overall balances for Wittig reactions with and without the recycling of TPPO (note: other starting or output materials of the Wittig reaction itself do not appear in the balance). The emissions are reduced as follows:

- phosphorus compounds: - 100 %
- chloride in waste water: - 66 %
- CO<sub>2</sub>: - 95 %.

The obtained Al(OH)<sub>3</sub> can be used in the on-site WWTP as a flocculation agent.

**Cross-media effects**

Waste water streams from the second extraction of the TPPO conversion.

**Operational data**

- phosgene is generated and immediately fed to the reactor; phosgene and chlorine are handled in a gas tight chamber, and
- treatment steps are carried out in stirred tank reactors.

**Applicability**

Applicable if the amount of TPPO generated justifies investment for recycling. Additionally off-site recycling is possible.

On-site TPPO recycling is possibly not economically feasible in custom manufacturing synthesis where limited amounts of TPPO are used [62, D1 comments, 2004].

**Economics**

- no comparison of conventional treatment/disposal costs and the recycling process obtained, but economic advantages can be presumed to be the driving force
- higher costs if phosgene technology has to be established on site.

**Driving force for implementation**

Process optimisation, economics.

**References to literature and example plants**

\*036L\*, [9, Christ, 1999]

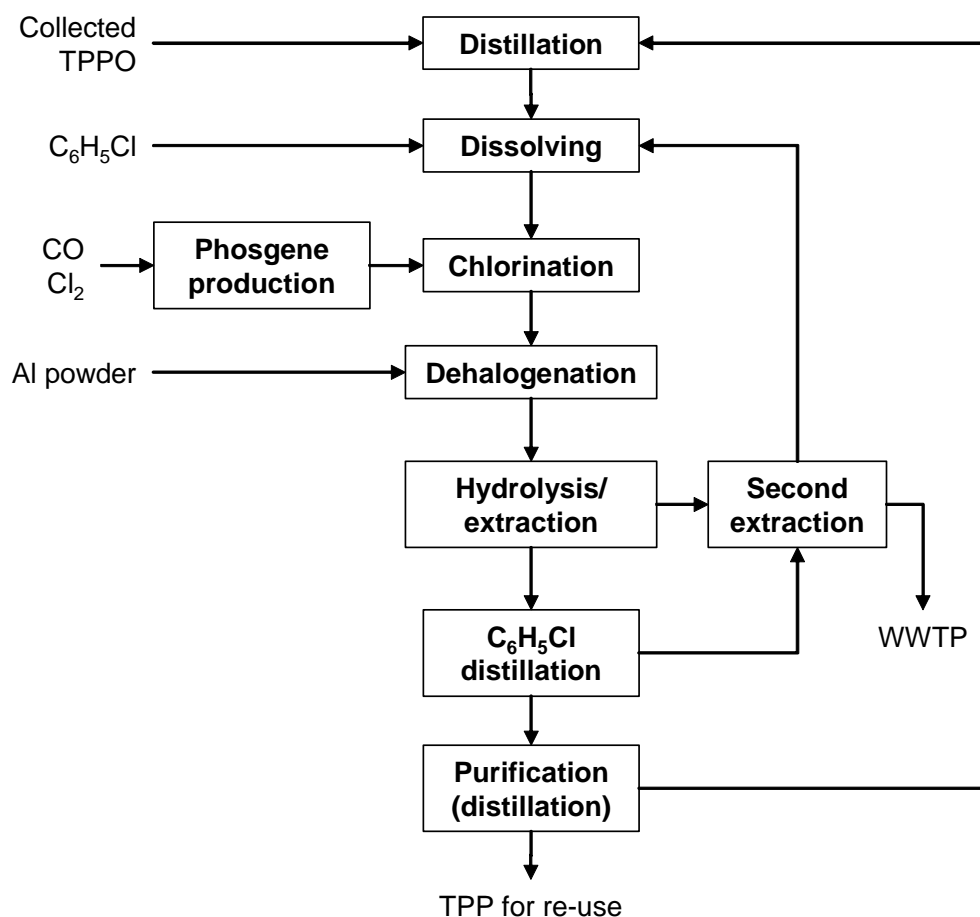

Figure 4.2: Steps in the conversion of TPPO to TPP

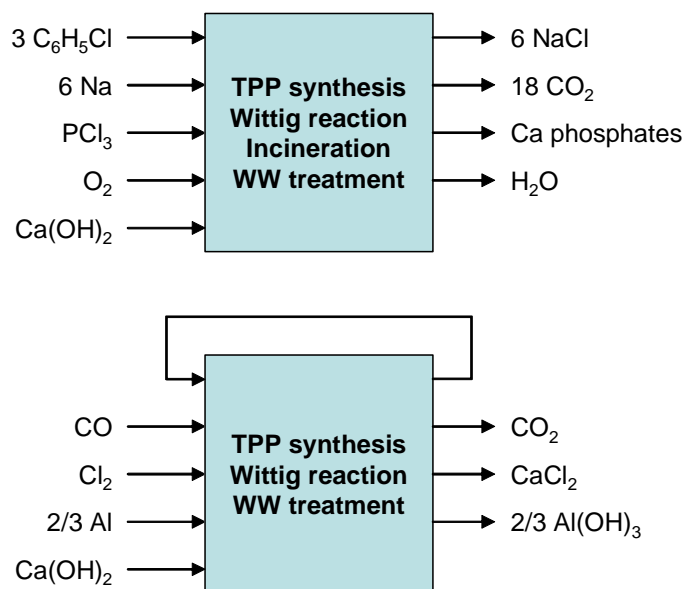

Figure 4.3: Overall balances for a Wittig reaction with and without recycling of TPPO

#### 4.1.4.4 Enzymatic processes versus chemical processes

##### Description

Using enzymatic processes instead of chemical processes is advantageous from an environmental point of view. Less synthesis steps (no additional modification or protection of functional groups) and low solvent use are the major beneficial effects. Energy savings, fewer safety and disposal issues, and improved product quality also lead to cost benefits. The enzyme can be used in solution or fixed on a substrate, or as part of a polyfunctional enzymatic system, e.g. in living cells, free in a reaction medium or fixed on a substrate.

##### Achieved environmental benefits

An example from the manufacture of 6-aminopenicillanic acid is presented in Table 4.6:

Chemical method	Enzymatic method
<i>Consumption of reactants</i>	
1000 t Penicillin G, potassium salt	1000 t Penicillin G, potassium salt
800 t N,N-dimethyl aniline	
600 t phosphorus pentachloride	
300 t dimethyl dichlorosilane	
	45 t ammonia
	0.5 – 1 t biocatalyst
<i>Consumption of solvents (recoverable, partly for disposal)</i>	
	10000 m <sup>3</sup> water
4200 m <sup>3</sup> dichloro methane	
4200 m <sup>3</sup> butanol	

**Table 4.6: Comparison of enzymatic and chemical processes  
Consumption levels for the conversion of 1000 t Penicillin G**

##### Cross-media effects

Higher water consumption.

##### Operational data

*No information provided.*

##### Applicability

The technical feasibility has to be considered individually.

Other examples with environmental advantages are [46, Ministerio de Medio Ambiente, 2003]:

- Aspartame
- 7-amino cefalosporanic acid
- anticonvulsive LY300164.

Where API manufacture on a site requires the observance of the rules of current Good Manufacturing Practice (cGMP) or approval by the Federal Drug Administration (FDA), process modifications can be only carried out fulfilling the required variation procedure. This represents a serious obstacle for the redesign of existing processes.

### **Economics**

Cost benefits.

### **Driving force for implementation**

Cost benefits.

### **References to literature and example plants**

[9, Christ, 1999, 46, Ministerio de Medio Ambiente, 2003]

#### 4.1.4.5 Catalytic reduction

##### Description

Most of the reduction processes carried out on an industrial scale can be performed by catalytic hydrogenation. This avoids the utilisation of stoichiometric amounts of other reduction agents which lead to the formation of large amounts of waste streams as, e.g. in the case of reduction with iron.

##### Achieved environmental benefits

Avoidance of waste stream formation, see also Table 4.32.

##### Cross-media effects

Hydrogenation may require the use of heavy metal compounds such as catalysts, which have to be recovered/recycled.

##### Operational data

*No information provided.*

##### Applicability

Applicable to most reduction processes on an industrial scale [6, Ullmann, 2001], but still in Organic Fine Chemistry other reducing agents may have decisive specific advantages [62, D1 comments, 2004]. Selective catalytic processes are generally superior to stoichiometric reactions [10, Anastas, 1996, 46, Ministerio de Medio Ambiente, 2003].

Find an example for the step from reduction with Fe to catalytic reduction in: [9, Christ, 1999]

There are cases where the iron oxide resulting from reduction processes are used as pigments [62, D1 comments, 2004].

##### Economics

- higher investment costs for hydrogenation equipment in comparison to a conventional reactor
- reduced disposal costs for residues
- cost of recovery of the catalyst
- increased safety requirements [99, D2 comments, 2005].

##### Driving force for implementation

- selectivity of the reaction
- higher efficiency for products with larger production volume
- disposal costs for residues.

##### References to literature and example plants

[6, Ullmann, 2001, 10, Anastas, 1996, 16, Winnacker and Kuechler, 1982, 46, Ministerio de Medio Ambiente, 2003], \*067D,I\*

### 4.1.4.6 Microstructured reactor systems

#### Description

Microreaction technology in chemical reaction engineering has experienced spectacular development in recent years, and is now also carried out on an industrial scale.

Microreactors are characterised by three-dimensional structures in the submillimetre range, with the following characteristics:

- mainly multi-channel reactors
- diameters from 10 to several 100 micrometers
- specific surface of 10000 to 50000 m<sup>2</sup>/m<sup>3</sup>
- high heat transfer performance
- short diffusion times, low influence of mass transfer on the rate of reaction
- isothermal conditions possible.

Figure 4.4 shows a five plate microreactor for the synthesis of a vitamin precursor in a stainless steel system with simultaneous mixing, reaction and heat transfer [6, Ullmann, 2001]. To obtain a product in a required amount, a certain number of microreactors have to be operated in parallel in arrays.

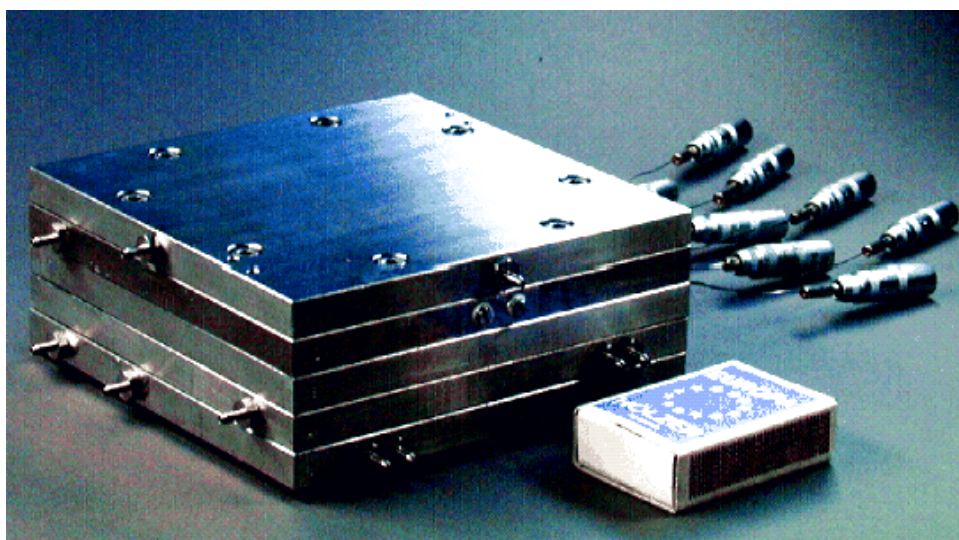

Figure 4.4: Five plate microreactor for the synthesis of a vitamin precursor

#### Achieved environmental benefits

- less waste streams, through the higher efficiency (process intensification) possible
- inherent reactor safety
- higher yields and less by-products.

#### Cross-media effects

*None believed likely.*

#### Operational data

- typical cell dimensions of 2 ml
- continuous flowrate of 1 – 10 ml/minute
- throughput of up to 140 g/hour.



## Applicability

[6, Ullmann, 2001]: A number of reactions have been successfully tested in microreactors, including high temperature reactions, catalysed reactions, and photochemical reactions.

Examples of production [69, Wuthe, 2004]:

- production capacity of 80 tonnes/year for speciality chemicals
- production of an organic pigment (20 tonnes/year).

Other examples:

- \*094I\*: replacement of batch processes with exotic or difficult classical chemistry
- \*095A,I\*: contract development and manufacture of intermediates and APIs.

## Economics

Table 4.7 gives a comparison of costs for a pilot production in a batch vessel and in the microreactor. Most important is the effect on the costs for bringing a product from laboratory to production scale, since the usual scale-up is replaced by a numbering up.

	50 litre batch vessel	Micro-reactor array
Investment	EUR 96632	EUR 430782
Scale-up effort	10 man days	0 man days
Mean yield	90 %	93 %
Specific solvent consumption	10.0 l/kg	8.3 l/kg
Required personnel per facility	2 men	1 man
Production rate	427 kg/year	536 kg/year
Specific production cost	EUR 7227/kg	EUR 2917/kg
Cost advantage of micro-reactor array		<b>EUR 2308529/year</b>
Return on investment		<b>0.14 year</b>

**Table 4.7: Comparison of costs for a pilot production in a batch vessel and in the micro-reactor**

## Driving force for implementation

Higher yields, process intensification.

## References to literature and example plants

\*094I\*, \*095A,I\*, [6, Ullmann, 2001, 40, Schwalbe, 2002, SW, 2002 #70, 69, Wuthe, 2004], [78, Boswell, 2004], [94, O'Driscoll, 2004], [70, SW, 2002] and references within

### 4.1.4.7 Reactions in ionic liquids

#### Description

Reactions can be carried out in ionic liquids, non miscible with organic solvents and showing no measurable vapour pressure. Therefore, the levels of VOCs are strongly reduced. The Biphasic Acid Scavenging utilising Ionic Liquids (BASIL) is now used on an industrial scale. Advantages are: no release of gaseous HCl, improved heat transfer, easy liquid-liquid separation, higher selectivity, can be used in existing plants, easy recycling of the IL (98 %) by simple treatment with caustic soda.

What are ionic liquids (IL)?

Ionic liquids are organic salts with melting points under 100 °C, often even lower than room temperature. Recently they have been used more and more as a substitute for the traditional organic solvents used in chemical reactions. The most common ones are imidazolium and pyridinium derivatives, but also phosphonium or tetralkylammonium compounds can be used for this purpose. Lately, environmentally friendly halogen-free ionic liquids have been introduced.

#### Achieved environmental benefits

- reaction rate enhancement, higher selectivities as well as higher yields, both result in a smaller amount of waste streams
- replacement of VOCs.

#### Cross-media effects

*None believed likely.*

#### Operational data

Depends on the individual case.

#### Applicability

\*036L\* uses an ionic liquid in the manufacture of alkoxyphenylphosphines, the first commercial use of the versatile materials in an organic process. The manufacture is carried out on a multi-tonne scale in a batch reactor at elevated temperatures. During the process, the ionic liquid separates as a clear liquid phase from the pure product and is recycled [65, Freemantle, 2003].

Possible applications are [66, Riedel, 2004]:

- as a solvent for synthetic and catalytic purposes, for example Diels-Alder cycloaddition reactions, Friedel-Craft acylation and alkylation, hydrogenation and oxidation reactions and Heck reactions
- as a biphasic system in combination with an organic solvent or water in extraction and separation technologies
- as catalyst immobilisation without the need of special functionalisation for the easy recycling of homogeneous catalysts
- as electrolytes in electrochemistry.

**Economics**

*No information provided*

**Driving force for implementation**

*No information provided*

**References to literature and example plants**

[62, D1 comments, 2004], [65, Freemantle, 2003], \*036L\*

### 4.1.4.8 Cryogenic reactions

#### Description

Reactions can be carried out in cryogenic batch reactors that work at very low temperatures: from -50 to -100 °C. The low temperature is generated by indirect cooling of the batch reactor with a suitable liquid, that in turn is cooled with liquid nitrogen.

#### Achieved environmental benefits

Under extreme cold, the reaction yield of some isomeric or stereoisomeric reactions can be considerably increased from 50 to more than 90 %. This gives a considerable saving in expensive intermediates and in reduction of waste streams, which has its effect on all previous reaction steps. This also prevents further waste streams and efforts from other workup steps that otherwise would be required to separate the impurities from the API or the intermediate.

#### Cross-media effects

Higher energy demand through the use of liquid nitrogen.

#### Operational data

Temperatures from -50 to -100 °C are required.

#### Applicability

Depends on the individual synthesis task.

#### Economics

*No information provided.*

#### Driving force for implementation

Selectivity and high reaction yield.

#### References to literature and example plants

[62, D1 comments, 2004], \*065A,I\*, 083A,I\*, \*084A,I\*

4.1.4.9 Reactions in supercritical CO<sub>2</sub>

## Description

Reactions can be carried out in supercritical CO<sub>2</sub> (supercritical point at 73.8 bar/31 °C) using a supercritical reactor system, as illustrated in Figure 4.5 for hydrogenations. Supercritical CO<sub>2</sub> replaces the solvent and shows similar properties to n-hexane. The reaction is no longer mass transfer controlled and hydrogen shows infinite solubility. Reaction conditions such as pressure, temperature, residence time and hydrogen concentration can be manipulated independently. On completion, the CO<sub>2</sub> is evaporated by reducing the pressure.

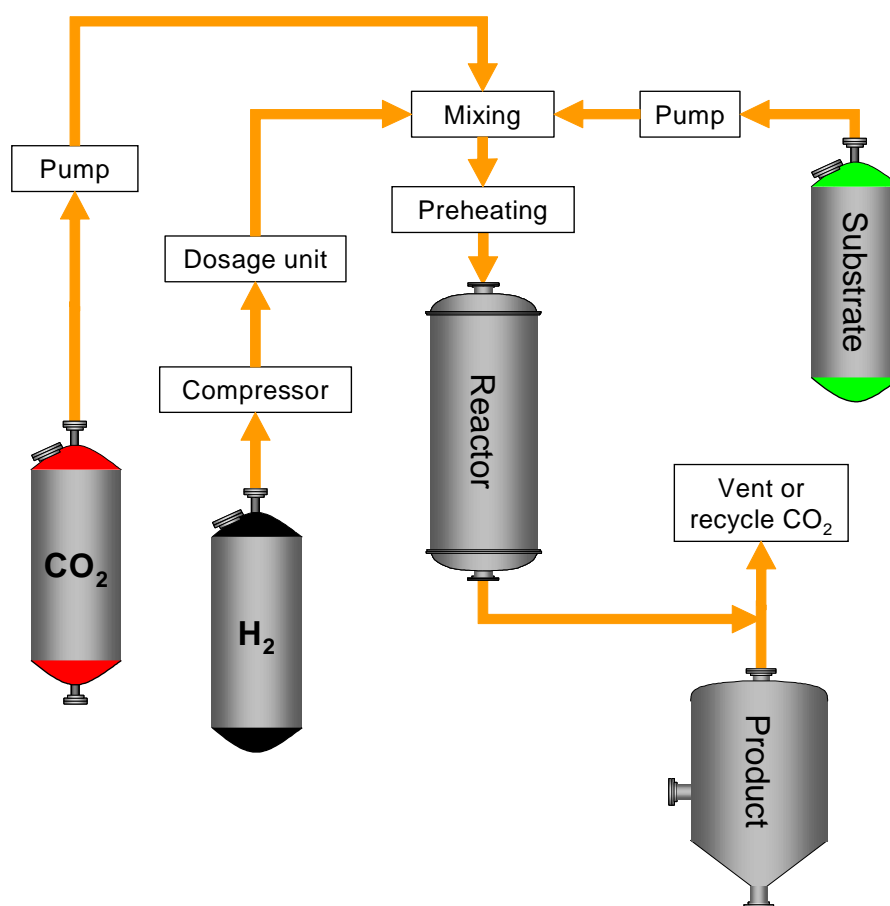

Figure 4.5: A supercritical reactor system

## Achieved environmental benefits

- low/no VOCs
- less waste streams
- higher selectivity
- higher yields.

## Cross-media effects

*None believed likely.*

### **Operational data**

Above 73.8 bar/31 °C.

### **Applicability**

Some reaction types under development besides hydrogenation include:

- alkylation
- acid catalysed reactions/etherifications
- hydroformylation.

### **Economics**

Reactions in supercritical CO<sub>2</sub> represent cost-intensive processes, but the costs are justified by selectivity, reduction of energy use, saving of costs for product workup and solvent disposal.

### **Driving force for implementation**

Selectivity through an inherently “tunable” system.

### **References to literature and example plants**

\*O21B,I\*

#### 4.1.4.10 Substitution of butyllithium

##### Description

Butyllithium is used in organic synthesis as a strong base for the deprotonation of hydrocarbons or metallation in aromatic chemistry. The reaction can create large amounts of highly volatile butane (boiling point:  $-0.5\text{ }^{\circ}\text{C}$ ) which can usually only be controlled by means of thermal oxidation.

Butyllithium can be replaced with other alkylolithium compounds with lower volatilities, e.g. hexyllithium generating hexane with a boiling point of  $68.7\text{ }^{\circ}\text{C}$ .

##### Achieved environmental benefits

- reduction of VOC emissions
- in particular cases, avoidance of advanced end-of-pipe techniques.

##### Cross-media effects

*None believed likely.*

##### Operational data

Possible generation of less volatile by-products, e.g. dodecane (as a result of a radical dimerisation process) which may require further cleaning operations and, therefore, additional resource consumptions.

##### Applicability

In one example, the reactivity of hexyllithium resembles that of butyllithium and it can thus principally be used for the same applications [6, Ullmann, 2001].

##### Economics

- possibly higher purchase costs for substitute alkylolithium
- limited availability of substitute alkylolithium on the market
- reduced costs as less abatement techniques are needed.

##### Driving force for implementation

Reduction of VOC emissions, economics.

##### References to literature and example plants

\*025A,I\*

### 4.1.5 Extraction from natural products

#### 4.1.5.1 Extraction from natural products with liquid CO<sub>2</sub>

See also Section 4.1.4.9.

##### **Description**

Supercritical CO<sub>2</sub> (supercritical point at 73.8 bar/31 °C) can replace the solvent in an extraction process, showing properties similar to hexane. Extracts of high quality and purity can be obtained without the typical problem of removal of the extraction solvent, since CO<sub>2</sub> is easily recycled by the application of suitable pressures.

##### **Achieved environmental benefits**

- no VOC emissions, no VOC recovery/abatement necessary
- high efficiency
- less effort for purification of the extract.

##### **Cross-media effects**

*None believed likely.*

##### **Operational data**

Pressures above 73.8 bar are required.

##### **Applicability**

Applicable where the solvent properties of supercritical CO<sub>2</sub> enable efficient extraction of a given extract. Preferred method for isolating heat sensitive material.

An example from [46, Ministerio de Medio Ambiente, 2003]: extraction of low volatile fragrances from spices or other dry raw material.

##### **Economics**

Capital intensive process. Detailed information not provided, but economic advantages can be assumed as the driving force for implementation.

##### **Driving force for implementation**

Information not provided, but economic advantages can be assumed as the driving force for implementation.

##### **References to literature and example plants**

[46, Ministerio de Medio Ambiente, 2003]



#### 4.1.5.2 Countercurrent band extraction

##### Description

Extraction yield in the extraction of plant materials can vary from 10 to 0.1 % or even lower, depending on the process technique, plant material quality and the targeted compounds. This means that the amount of waste streams compared to amount of end-product is considerable. To reduce the amount of waste streams, it is important to maximise the extraction yield, e.g. by using countercurrent band extraction.

##### Achieved environmental benefits

Higher extraction yields.

##### Cross-media effects

*None believed likely.*

##### Operational data

*No information provided.*

##### Applicability

Generally applicable.

##### Economics

Cost benefits through higher yields, and lower costs for disposal of residual material.

##### Driving force for implementation

Efficiency improvement.

##### References to literature and example plants

[62, D1 comments, 2004], \*065A,I\*

### 4.1.5.3 Enabling the re-use of residual plant material from extraction

#### Description

An “ideal” extraction solvent satisfies the following requirements:

- high, selective dissolving capacity: only the required extract and no other constituents of the feed material are dissolved
- low specific heat, relative density, and heat of vaporisation
- non-flammable, no formation of explosive mixtures with air
- nontoxic
- non-corrosive action on the extraction equipment
- good ability to penetrate the feed material, easy and complete removal from the extract and extraction residue without affecting their odour or taste
- chemically defined, homogeneous, stable; it has a constant boiling point which is not too high.

No solvent fulfills all of these conditions, and the optimum solvent must be found for each extraction process.

The use of easily degradable solvents enables the simple disposal and potential re-use of the extraction residue.

#### Achieved environmental benefits

Enabling the re-use of residual plant material from extraction.

#### Cross-media effects

*None believed likely.*

#### Operational data

*No information provided.*

#### Applicability

Generally applicable.

#### Economics

Lower costs for the disposal of residual material.

#### Driving force for implementation

Efficiency improvement.

#### References to literature and example plants

[62, D1 comments, 2004], \*065A,I\*

## 4.1.6 Safety assessment

Safety assessment is introduced in this document as it can help to prevent accidents with potentially significant environmental impacts. However, this subject could not be entirely dealt within this document. The field of process safety is much wider than presented here and this section should be treated as an initial overview. Section 4.1.6.3 contains a list of references for additional information.

### 4.1.6.1 Physico-chemical safety assessment of chemical reactions

#### Description

A structured safety assessment for a reaction in a certain process in a given plant can be performed according to the scheme given in Figure 4.6. The assessment is carried out for normal operation (see Figure 4.7) and takes into account effects due to deviations of the chemical process and deviations in the operation of the plant (see Table 4.8).

All the relevant physico-chemical safety data of substances and reactions should be evaluated in respect with the necessary equipment along with technical and organisational safety precautions. Important physico-chemical parameters to be taken into account are, e.g:

- reaction enthalpies ( $\Delta H_R$ ) both for the reaction concerned and for potential secondary reactions (e.g. decomposition)
- possible gas evolution (M) and the rate of gas evolution (dM/dt) or corresponding derived parameters from the reaction or the possible decomposition
- rate of heat production (dQ<sub>R</sub>/dt), where appropriate as a function of temperature
- total heat removal capacity of the system (dQ<sub>R</sub>/dt)
- limit temperature (T<sub>exo</sub>) for the thermal stability of the substances concerned and the reaction mixtures under process conditions
- formation of new unwanted products or by-products ( $\Delta n$  subst.), which lead to an increase in the reaction enthalpy or gas formation or a reduction of the limit temperature (T<sub>exo</sub>).

Measures to ensure that a process can be controlled adequately include (without ranking):

#### Preventive measures

- (preferred)
- organisational measures
  - concepts involving control engineering techniques
  - reaction stoppers
  - emergency cooling

#### Design measures

- pressure resistant construction
- pressure relief including sufficient catch volume

#### Achieved environmental benefits

Prevention of major accidents and substance releases.

#### Cross-media effects

*None believed likely.*

### **Operational data**

*No information provided.*

### **Applicability**

Similar to chemical reactions and also applicable to other operations, e.g. drying or distillation. Important safety examples are the handling of organic dusts or solvent vapours.

### **Economics**

- additional costs for safety measures
- high costs in the case of pressure resistant construction.

### **Driving force for implementation**

Process safety.

### **References to literature and example plants**

[42, TAA, 1994], [100, TAA, 2000] and literature within.

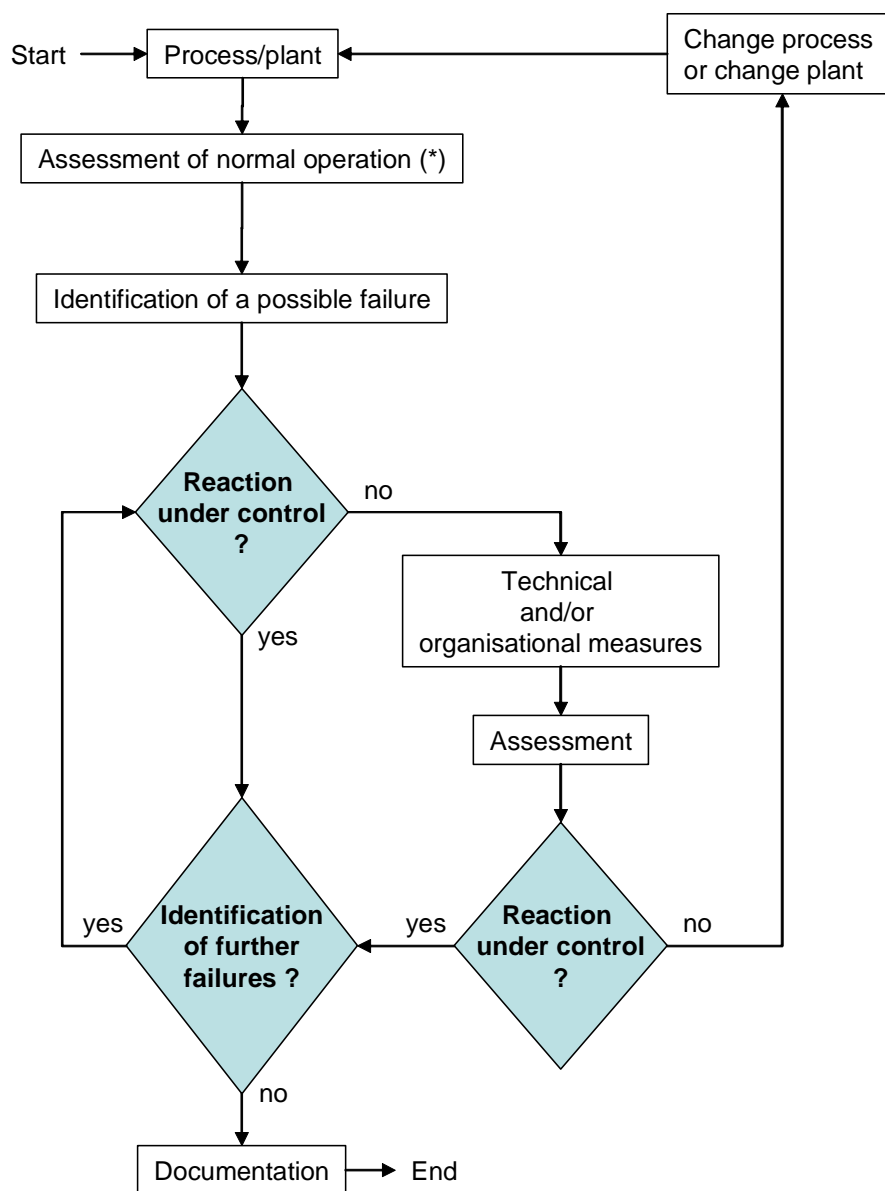

**Figure 4.6: Safety assessment procedure**  
Note: (\*) see Figure 4.7

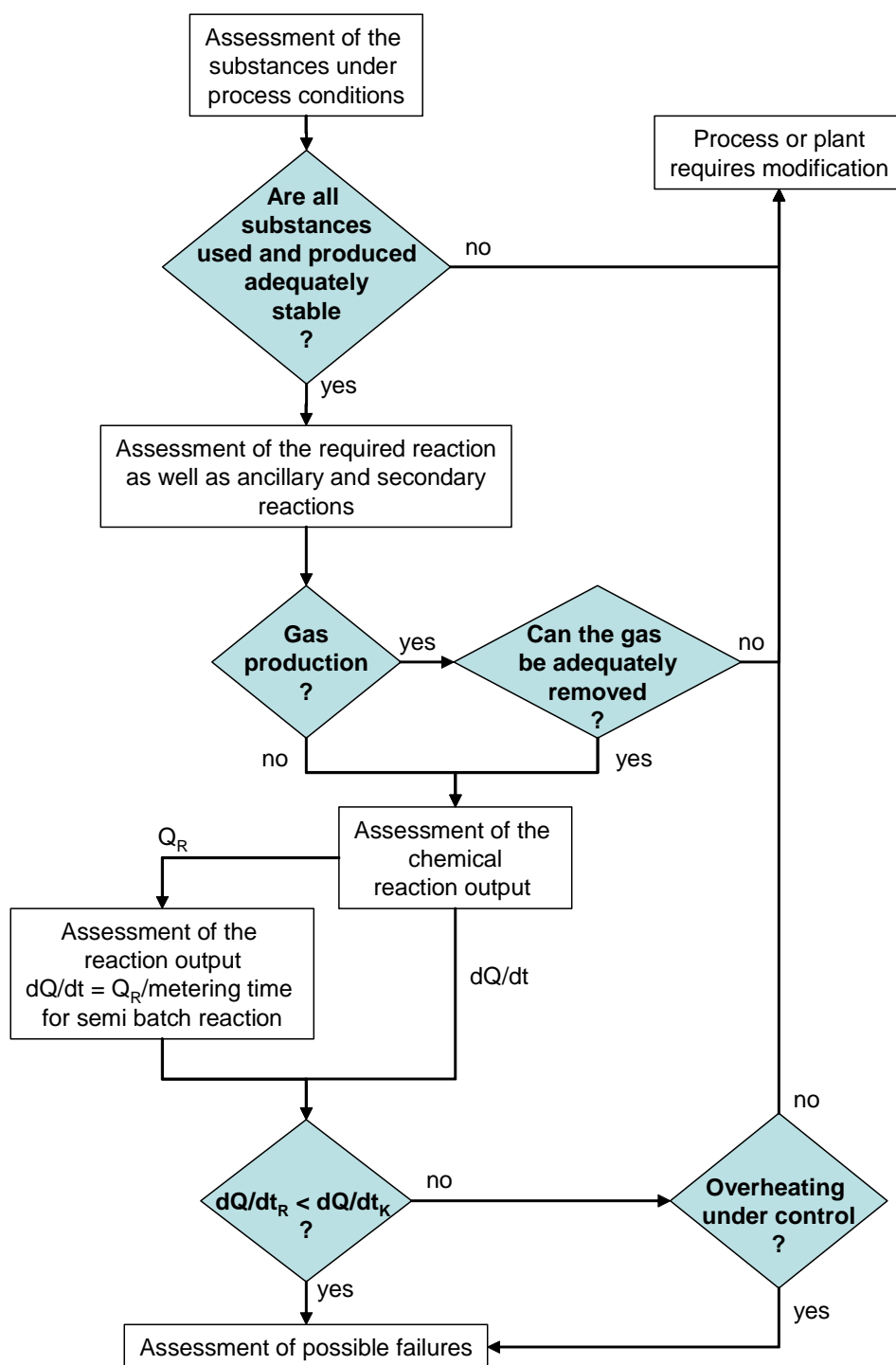

Figure 4.7: Iterative assessment strategy for normal operations

Failure caused by	$\Delta H_R$	dM/dt	$\frac{(dQ_R/dt)}{(dQ_K/dt)}$	$T_{\text{exo}}$	$\Delta n$ subst.
<b>Effects due to deviations of chemical processes</b>					
Starting materials (specification, nature, property), e.g. <ul style="list-style-type: none"> <li>contamination with catalytic effect</li> <li>increased/decreased of concentration</li> <li>residues from previous use</li> <li>decomposition of activators/inhibitors (e.g. as a result of extended storage)</li> </ul>					
Presence of starting materials/auxiliary materials, e.g. <ul style="list-style-type: none"> <li>solvent used</li> <li>solution promoter</li> <li>activator/inhibitor</li> </ul>					
Metering, e.g. <ul style="list-style-type: none"> <li>wrong substance, wrong quantities/ratios</li> <li>changed metering sequence</li> <li>wrong metering rate</li> </ul>					
Reaction conditions, e.g. <ul style="list-style-type: none"> <li>change in pH value</li> <li>temperature increase/decrease</li> <li>reaction/residence time, delayed reaction start</li> <li>increase of by-products/residues</li> </ul>					
Mixing, e.g. <ul style="list-style-type: none"> <li>inadequate agitation</li> <li>separation of solids/catalysts</li> </ul>					
<b>Effects due to deviations in the operation of the plant</b>					
Availability of auxiliary energy, e.g. <ul style="list-style-type: none"> <li>compressed air, nitrogen</li> <li>electric current</li> <li>heating medium, cooling medium</li> <li>ventilation</li> </ul>					
Heating/cooling medium (temperature), e.g. <ul style="list-style-type: none"> <li>temperature exceeds/falls below the temperature defined for safe process operation</li> </ul>					
Process equipment, e.g. <ul style="list-style-type: none"> <li>failure</li> </ul>					
Material flows, e.g. <ul style="list-style-type: none"> <li>failure of pumps/valves</li> <li>incorrect operation of valves</li> <li>blocking of lines/valves/fittings (in particular venting pipes)</li> <li>backflow from other parts of the plant</li> </ul>					
Filling level, e.g. <ul style="list-style-type: none"> <li>overfilling</li> <li>leakage from a dump valve</li> <li>flooding of condensers (heat-exchangers)</li> </ul>					
Agitation, e.g. <ul style="list-style-type: none"> <li>failure</li> <li>increased viscosity</li> <li>mechanical introduction of heat</li> </ul>					
Integrity of components <ul style="list-style-type: none"> <li>corrosion (in particular with resulting material overflow from/to heat transfer systems)</li> <li>mechanical damage</li> </ul>					

Table 4.8: Effects due to deviations of chemical processes or the operation of the plant

### 4.1.6.2 About the prevention of runaway reactions

#### Description

The consequences of a runaway reaction can be severe. Therefore, facilities must focus on prevention of conditions favourable for a reaction excursion through process design control, instrumentation, and interlocks to prevent the recurrence of similar events. Facilities should take the following steps to prevent runaway reactions:

- modify processes to improve inherent safety. Consider inherently safer processes to reduce reliance on administrative controls
- minimise the potential for human error
- understand events that may lead to an overpressure and eventually to vessel rupture
- use lessons learned. Go beyond the issues of quality control and operator error and identify true root causes
- evaluate Standard Operating Procedures (SOPs)
- evaluate employee training and oversight
- evaluate measures to inhibit a runaway reaction (e.g. neutralisation, quenching)
- evaluate the effectiveness of the emergency relief system.

#### Achieved environmental benefits

Prevention of runaway reactions and related consequences.

#### Cross-media effects

*None believed likely.*

#### Operational data

*No information provided.*

#### Applicability

Generally applicable, especially in the case of exothermic reactions. Also relevant for stored goods with potential for autoreaction (e.g. warm storage experiments for acrylnitrile).

#### Economics

*No information provided.*

#### Driving force for implementation

Prevention of accidents and consequent emissions to the environment.

#### References to literature and example plants

[72, EPA, 1999]



#### 4.1.6.3 Useful links and further information

- Barton, J., R. Rogers (Eds.) (1993). "Chemical Reaction Hazards – a Guide", ICgemE, Rugby, GB
- Bretherick, L. (1990). "Handbook of Reactive Chemical Hazards", 4. ed., Butterworths, London
- Grewer, T. (1994). "Thermal Hazards of Chemical Reactions", Elsevier, Amsterdam
- Process Safety Progress (journal), accessible in <http://www3.interscience.wiley.com/cgi-bin/jhome/107615864>
- Steinbach, J. (1995). "Chemische Sicherheitstechnik", VCH Weinheim
- Technische Regel für Anlagensicherheit - TRAS 410 Erkennen und Beherrschen exothermer chemischer Reaktionen, Reihe 400 Sicherheitstechnische Konzepte und Vorgehensweisen, Fassung April 2000, (Bundesanzeiger Nr. 166a vom 05.09.2001); Technischer Ausschuss für Anlagensicherheit - Sicherheitstechnische Regel des TAA. Accessible in [http://www.sfk-taa.de/Berichte\\_reports/TRAS/tras\\_neu.htm](http://www.sfk-taa.de/Berichte_reports/TRAS/tras_neu.htm).

## 4.2 Minimisation of environmental impacts

### 4.2.1 A “state of the art” multipurpose plant

#### Description

The new production site \*037A,I\* manufactures pharmaceuticals and performs reactions such as chiral synthesis, biocatalysis, Grignard reactions, Friedel-Crafts reactions, bromination, chlorination, aromatic substitutions, metal hydride reductions.

Major aspects have been considered as follows:

- several techniques were considered to control VOC emissions, including: extra condensers, cryogenic condensation, scrubbing, thermal oxidation. The choice was made for thermal oxidation because all possible emissions on the site can be treated at once. Furthermore, the thermal oxidiser can be used as an energy provider for the plant
- the characteristic value for residue production is about 15 tonnes residue per tonne product. Products are made in quantities of up to 100 tonnes/year/product. Recycle loops are, in many cases, not possible due to quality and purity requirements. Only the solvents that are contaminated with, for example halogenated compounds or salts, are disposed of to a waste treatment plant
- a survey is being carried out to make processes more selective and, therefore, produce less sludge at the WWTP, as the sludge has to be processed abroad
- other measures to prevent residues include: using enzymes in the processes, performing reactions at lower temperatures, racemise after the reaction is completed
- there is one process with **runaway hazard**. The temperature is measured in the reactor during start off to check if the reaction is running according to the instructions. The **reaction is quenched** if the temperature rises above the alarm setpoint.

The plant is designed in such a way that diffuse emissions are minimised and that the energy efficiency is optimised:

On the top floor (5th floor), starting materials can be weighed and loaded in closed rooms. Products fall into the reactors that hang on the 3rd floor, using gravity instead of pumps and/or vacuum. **This prevents uncontrolled emissions to a large extent, since pumps are an important source of uncontrolled emissions**, and can save energy. On the 4th floor (thus between weighing and reactors) hang **(double) condensers** using thermal oil as the cooling medium. Solvents can either be returned to the reactors or run to a reception vessel. **All systems are closed** to prevent uncontrolled emissions. On the lower floors, products fall from the reactors into vessels where reception and drying functions are combined. Here again gravity does the work instead of pumps/vacuum. On each floor, pipes gather to a manifold. Apparatus can be connected to each other in different configurations using flexible pipes, depending on the process steps needed, thus preventing the use of building materials. Packings are replaced when a production campaign is finished (i.e. when a switch is made to the synthesis of a different product) to make sure the system remains safe and no uncontrolled emissions occur. When the configuration of the equipment is adapted to the new process, the packings are changed and the equipment is set under pressure in order to detect potential leaks. Inside the reactor during production, a **light overpressure of nitrogen slightly decreases the evaporation of VOCs** (blanketing). The building is closed and ventilated mechanically. The pressure inside the building is 10 % higher than outside. The building is divided into fireproof compartments which are individually ventilated. All emitted gases from these compartments are either recycled, or after waste heat recovery, released to the air. All condensers and vents from sewage are connected to the thermal oxidiser to make sure all point emissions are treated. Waste water vents are also connected to the thermal oxidiser.

**Achieved environmental benefits**

- high energy efficiency
- consequent minimisation of diffuse/fugitive emissions
- extended recovery and abatement of VOC emissions.

**Cross-media effects**

*None believed likely.*

**Operational data**

*No information provided.*

**Applicability**

Generally applicable for new installations (including buildings). Technical restrictions may lead to individual solutions. For example the use of gravity flow is not applicable for high viscosity liquids [99, D2 comments, 2005].

Alternatively to the use of gravity flow, canned pumps can be used to prevent fugitive emissions [99, D2 comments, 2005].

**Economics**

Cost benefits can be presumed through higher efficiency.

**Driving force for implementation**

Cost and environmental benefits, and efficiency.

**References to literature and example plants**

\*037A,I\*

## 4.2.2 Site assessment before process launch

### Description

Site assessment before process launch is one part of the decision process. At the latest after the required processes and operations to manufacture a new product are finally selected (“process freeze”), the decision has to be made where this product will be launched. Basically, a new product can be launched on existing (own or someone else’s) sites or the product launch is realised by establishing a new site. Many factors influence this decision such as investment/operating costs, the availability of resources like scientific/technical staff or feedstock and product logistics.

From an environmental point of view, major issues after “process freeze” are, e.g. the management of waste streams (consideration of recovery, re-use, abatement and disposal options) and transportation of feedstocks and products/wastes. Figure 4.8 illustrates the assessment of two sites concerning transportation and Figure 4.9 illustrates the assessment of two sites concerning the management of waste streams arising from processes/operations to be launched.

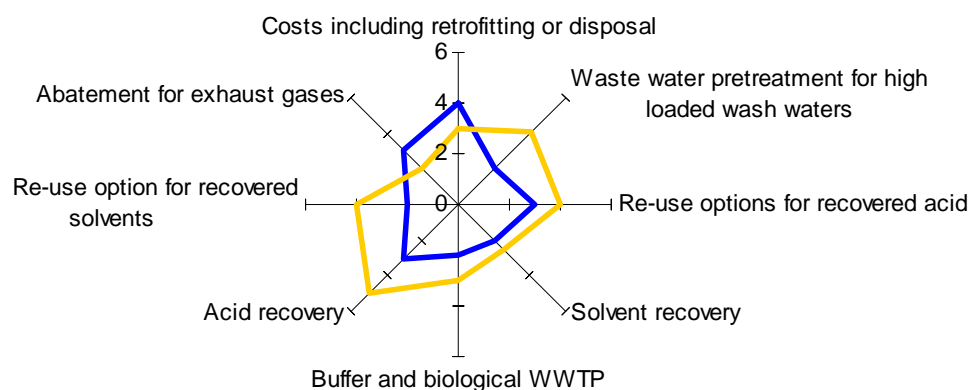

**Figure 4.8: Assessment of two sites concerning transportation**  
Each criterion is given an evaluation value of between 0 = positive and 5 = negative

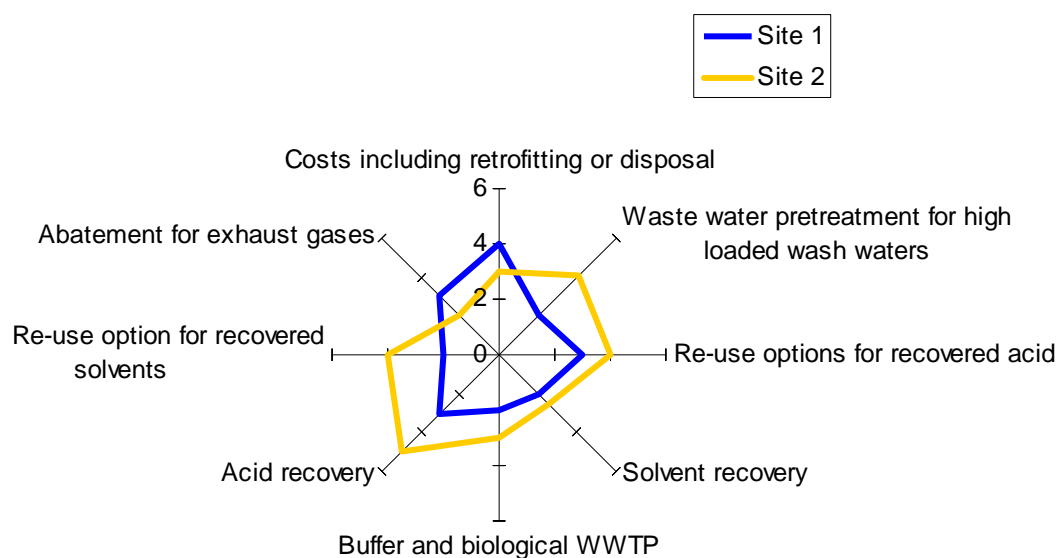

**Figure 4.9: Assessment of two sites concerning the waste streams from a new production**  
Each criterion is given an evaluation value of between 0 = positive and 5 = negative

**Achieved environmental benefits**

- early assessment creates the basis for finding the environmentally advantageous site
- identification of the site with the highest potential for enabling recycling/re-use of recovered material.

**Cross-media effects**

*None believed likely.*

**Operational data**

*No information provided.*

**Applicability**

Generally applicable.

**Economics**

No issues.

**Driving force for implementation**

The need to create a basis for decisions.

**References to literature and example plants**

[62, D1 comments, 2004], \*066I\*

### 4.2.3 Precautions in the production of herbicides

#### Description

On the \*085B\* site, the production of herbicides requires the handling of toxic starting materials and products. The precautions taken are described in Table 4.9.

<b>Raw material supply</b>	Starting materials are delivered in closed containers, allowing safe and low emission unloading.
<b>Unloading</b>	Unloading in a concreted secured area with an underground tank to collect the toxic liquid in case of spillage or accident; unloading is carried out with a gas balancing system to minimise diffuse emissions.
<b>Handling of raw materials, intermediates and products</b>	All handling is carried out in closed systems without any manual operations.
<b>Automation</b>	The whole plant is operated with a process control system which enables smooth and stable operation of the plant as well as constant product quality.
<b>Sealing of the plant</b>	The plant is completely sealed and held under slight overpressure of 25 mbar (N <sub>2</sub> blanket) in order to identify even small leakages at once. Overpressure is maintained by special valves and control systems to avoid sucking effects and to inject N <sub>2</sub> when required.
<b>Make-up of the final product</b>	The solid products are pelletised (no flakes!) to minimise dust generation.
<b>Storm-water and water from rinsing/cleaning</b>	Water from cleaning operations is treated in a special activated carbon moving bed adsorber before biological treatment.  All storm-water is collected via ring drainage (all around the production unit) in four covered collection tanks and is analysed for herbicide and AOX. If AOX is below 1 mg/l and herbicide is below 5 µg/l, it can be discharged, otherwise it is treated by active carbon adsorption.

**Table 4.9: Precautions taken on the referenced herbicide production site**

#### Achieved environmental benefits

Minimisation of environmental issues.

#### Cross-media effects

*None believed likely.*

#### Operational data

*No information provided.*

**Applicability**

Generally applicable.

**Economics**

Higher costs for equipment and maintenance. Improved efficiency through automation.

**Driving force for implementation**

Minimisation of environmental issues, efficiency through automation.

**References to literature and example plants**

[68, Anonymous, 2004], \*085B\*

### 4.2.4 Improvement of “letter acid” production

#### Description

Naphthalene sulphonic acids (also called “letter acids”) are widely used as intermediates in dye/pigment manufacture. Sulphonic groups give the molecule the required water solubility for the application in aqueous solution. Different applications are enabled by a variety of substitution patterns which are most commonly synthetically achieved by sulphonations, nitrations, reductions and alkali fusion. The environmental issue is the creation of a considerable amount of waste streams, including a large amount of by-products. Table 4.10 illustrates this for the production of J acid (1-hydroxy-6-aminonaphthalene-3-sulfonic acid) according to the conventional process.

Starting materials (tonnes)	Waste streams and product (tonnes)		
13.3	7.0	Inorganic salts	68 m <sup>3</sup> waste water streams
	1.0	Organic by-products, non degradable	
	4.0	Solid residues	Waste gas
	0.3	SO <sub>x</sub> , NO <sub>x</sub>	
	1.0	Product	

**Table 4.10: Mass balance for the manufacture of J acid (conventional process)**

For this reason the conventional production process, as well as the treatment of the remaining waste streams, have been revised. Table 4.11 shows the example of the revision of the production of H acid. The improved process was realised on the \*067D,I\* site.

Task	Improvement	Environmental benefit
Improve yield	Modern process control system, less variation of process parameters	-20 % starting materials consumption (naphthalene, H <sub>2</sub> SO <sub>4</sub> , CaCO <sub>3</sub> , HNO <sub>3</sub> )
	Replacement of several intermediate steps by a continuous system	
Avoid or re-use Fe <sub>3</sub> O <sub>4</sub> sludge from reduction	Re-use for iron oxide pigment production	Not realised
	Catalytic reduction with H <sub>2</sub>	-100 % Fe <sub>3</sub> O <sub>4</sub> sludge
Minimise the volume of waste water streams	Omission of intermediate isolation steps	-70 % waste water streams
	Replacement of several intermediate steps by a continuous system	
	Introduction of an intermediate evaporation stage	
Organic loadings in waste water streams	Application of high pressure wet oxidation	COD elimination 98 %
Salt content of the waste water streams	Avoidance of a salting out process by water volume minimisation	-100 % NaCl consumption
	Omission of intermediate isolation steps	
Safe abatement of VOC, NO <sub>x</sub> (and H <sub>2</sub> )	Apply thermal oxidation	Lower emission levels

**Table 4.11: Revision of the H acid process**



Due to the omission of several isolation steps in the revised process, the resulting mother liquor from H acid separation shows the following properties:

- COD: 45 kg/m<sup>3</sup>
- COD: 1.17 tonnes/tonne H acid
- volume: 26 m<sup>3</sup>/tonne H acid
- bioeliminability: non-bioeliminable.

The wet oxidation is operated at 120 – 150 bar and 240 – 300 °C.

### **Achieved environmental benefits**

See Table 4.11.

### **Cross-media effects**

*None believed likely.*

### **Operational data**

See description.

- basically a new plant was built
- effects of the added recovery/abatement techniques.

### **Applicability**

The example from \*067D,I\* represents basically the building of a new plant. The starting point was a process that was 100 years old and operational in an old plant with poor infrastructure.

### **Economics**

No detailed information was provided, but since basically a new plant including new infrastructure, thermal oxidiser and a wet oxidation facility was built, a major investment can be presumed.

### **Driving force for implementation**

Amongst other factors: age and poor infrastructure of the old plant, along with its emission levels.

### **References to literature and example plants**

[6, Ullmann, 2001, 9, Christ, 1999, 16, Winnacker and Kuechler, 1982, 68, Anonymous, 2004, 76, Rathi, 1995], [86, Oza, 1998], \*067D,I\*, \*091D,I\*

## 4.2.5 Water-free vacuum generation

### Description

Water-free vacuum generation is achieved by using mechanical pumping systems in a closed circuit procedure or by means of dry running pumps.

For example sliding rotary vacuum pumps (with or without lubrication oil) can be used in order to avoid the contamination of water with pumped substances (Figure 4.10). With these, the vapours are drawn under reduced pressure through a pre-condenser to a Roots vacuum pump and are forwarded by two sliding vane rotary pumps arranged in parallel to more condensers to the waste gas treatment system (thermal oxidiser). The pumps require water cooling.

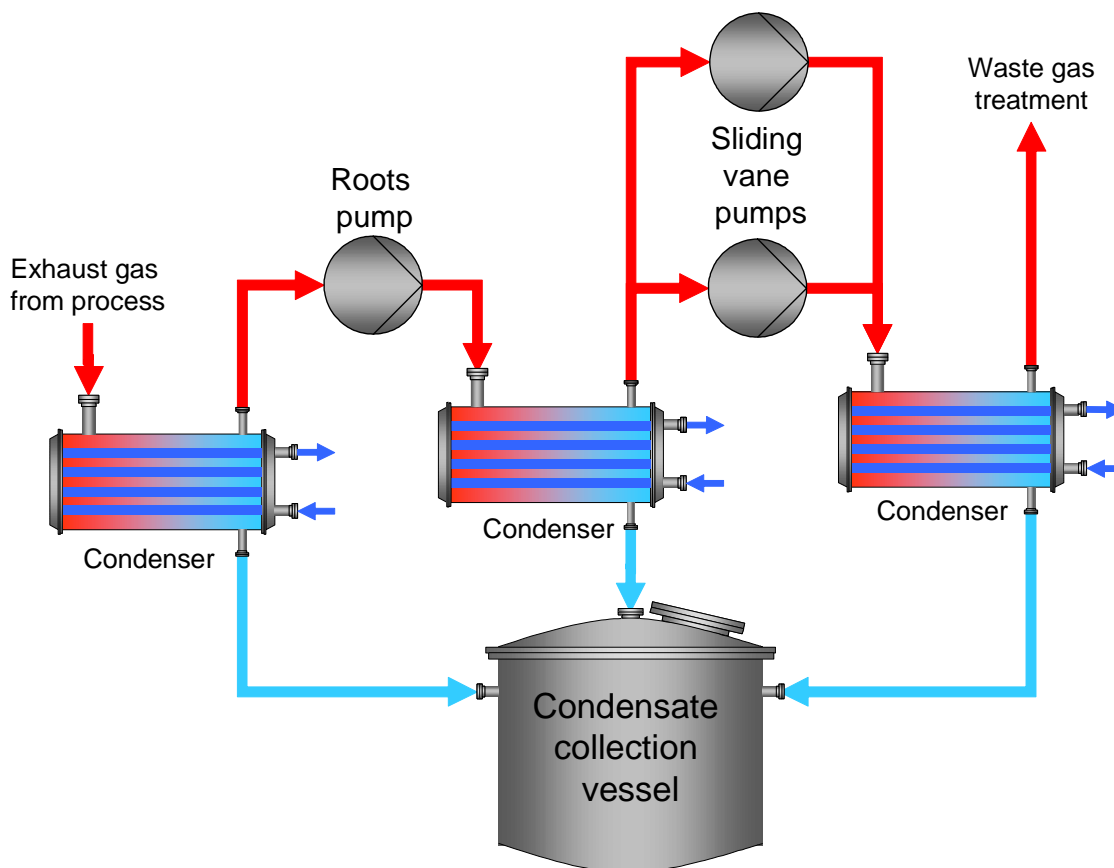

Figure 4.10: Example for vacuum generation without a resulting contamination of water

### Achieved environmental benefits

Avoidance of water contamination in vacuum generation.

### Cross-media effects

*None believed likely.*

### Operational data

*No information provided.*

### Applicability

Widely applicable.

It is a precondition that the gases can be prevented from condensing in the pump, e.g. by means of a high gas outlet temperature. Dry running pumps cannot be used especially if condensable substances (e.g. water vapour) or dust- or coating-forming or polymerising substances are present in the gas stream in relatively large amounts [62, D1 comments, 2004].

The use of dry running pumps is restricted in case the gas stream contains corrosive substances [99, D2 comments, 2005].

Where lubrication oil is used, the pumped vapours can decrease the lubricity of the oil of rotary sliding vane vacuum pumps [62, D1 comments, 2004].

Dry running pumps are usually restricted to temperature classes Ex T3 and cannot be used where an application requires Ex T4 conditions (\*010A,B,D,I,X\*)

In comparison, water-jet and vapour-jet vacuum pumps, owing to their highly viable operation, lower maintenance requirements and favourable costs, can be used universally [62, D1 comments, 2004].

Re-use of solvents may be restricted in the manufacture of APIs due to concerns about impurities/cross-contamination [62, D1 comments, 2004]. Recovery of any organic solvent may be restricted in the manufacture of explosives due to concerns about safety risks [99, D2 comments, 2005].

### Economics

A dry vacuum pump investment is much higher than a water ring vacuum pump but on a long term basis, the total cost can be balanced because of the cost to treat the liquid ring water.

\*113I,X\* provides an example of an installation where three water ring pumps were replaced by two new dry running vacuum pumps. In Table 4.12, the operating costs of the old and the new installation are compared. The investments in the new vacuum generation technique including safety equipment and installation were net EUR 89500 (175000 DEM) (in 1999). The payback time is thus one year.

		Amount/year	Costs EUR/year
<b>Old installation with water ring pumps:</b>			
Energy requirement	27 kW × 8000 h	216000 kWh	13250
Water requirement (EUR 1.12/m <sup>3</sup> )	2.8 m <sup>3</sup> /h × 8000 h	22400 m <sup>3</sup>	25100
Created waste water (EUR 3.07/m <sup>3</sup> )	2.8 m <sup>3</sup> /h × 8000 h (COD: 1200 mg/l)	22400 m <sup>3</sup>	68770
<b>Total</b>			<b>107120</b>
<b>New installation with dry running vacuum pumps (no effluents):</b>			
Energy requirement	35 kW × 8000 h	280000 kWh	17180
<b>Total</b>			<b>17180</b>
<b>Operating cost savings</b>			<b>89940</b>

**Table 4.12: Comparison of operating costs of two vacuum generation techniques**  
Currency was converted from DEM to EUR using conversion factor 1 EUR = 1.95583 DEM

### Driving force for implementation

Reduction of waste water loads, and economics.

### References to literature and example plants

[9, Christ, 1999], [106, Koppke, 2000], \*010A,B,D,I,X\*

## 4.2.6 Liquid ring vacuum pumps using solvents as the ring medium

### Description

If a single (and not highly volatile) solvent is pumped, a liquid ring pump using the same solvent as the medium can be applied in combination with a solvent recovery system, as shown in Figure 4.11. Besides the avoidance of potential water contamination, the usage of solvents as the ring medium shows other advantages:

- the vacuum is maintained by cooling, which is restricted in the case of water to values above 0 °C but more flexible if a solvent with lower melting point is chosen
- better vacuum can be achieved by using solvents with a lower vapour pressure than water.

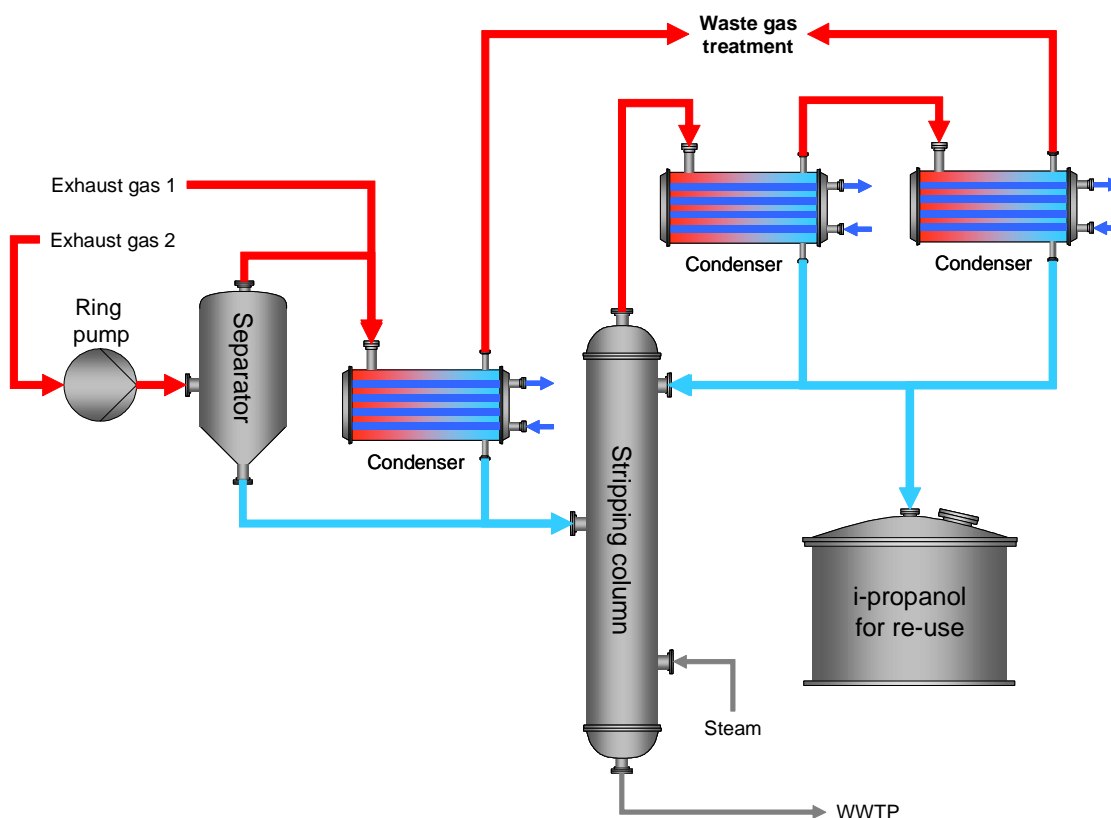

Figure 4.11: Layout for a liquid ring pump using i-propanol as the ring liquid

### Achieved environmental benefits

Avoidance of water contamination in vacuum generation.

### Cross-media effects

*None believed likely.*

### Operational data

Example from \*010A,B,D,I,X\*:

- use of toluene as the ring liquid
- exhaust gases from condensers are treated by thermal oxidation.

Energy use for cooling and steam generation. In comparison to a plain dry running vacuum pump, additional treatment of the exhaust gas may be required.

### **Applicability**

Generally applicable.

The re-use of recovered solvents may be restricted in the manufacture of APIs [62, D1 comments, 2004] and of explosives [99, D2 comments, 2005].

In the given example, the water from the stripping column is forwarded to the WWTP. In other cases the characterisation of such water may lead to other options.

As a rule of thumb, the stripping process is economically feasible only for more than 1000 kg of solvent per day [62, D1 comments, 2004].

### **Economics**

No comparison of costs was possible for the conventional ring pump compared to the solvent ring pump due to data not being provided, but economic advantages are assumed to be the main driving force.

Where solvents cannot be re-used, the economic benefit will be limited [62, D1 comments, 2004].

### **Driving force for implementation**

Reduction of waste water loads, and economics.

### **References to literature and example plants**

[9, Christ, 1999], \*010A,B,D,I,X\*

## 4.2.7 Closed cycle liquid ring vacuum pumps

### Description

Liquid ring vacuum pumps can be designed for total recirculation of the sealing liquid. The system normally includes a pump suction condenser with condensate recovery tank and a post condenser for the condensation of residual gas. The construction materials are normally CrNiMo stainless steel and all process side related seals are made of PTFE.

### Achieved environmental benefits

- a much reduced amount of sealing liquid (e.g. water) is contaminated
- completely closed system, no contact between cooling and sealing liquid
- handled gases/vapours (e.g. solvents) are recovered.

### Cross-media effects

*None believed likely.*

### Operational data

The recirculated sealing liquid has to be considered for disposal after a certain time.

### Applicability

Widely applicable.

The re-use of recovered solvents may be restricted in the manufacture of APIs [62, D1 comments, 2004]. Not applicable for the manufacture of explosives due to safety concerns [99, D2 comments, 2005].

### Economics

*No information provided.*

### Driving force for implementation

Reduction of waste water loads, and economics.

### References to literature and example plants

\*042A,I\*, \*010A,B,D,I,X\*

## 4.2.8 Pigging systems

### Description

Pigging technology is a subdivision of materials transport and cleaning technology. In pigging, the contents of a pipe are pushed by a close fitting plug (pig), with the aim being to push the product almost completely out of the pipe. The pig is most frequently driven by a gaseous propellant (e.g. compressed air). The main components of an industrial pigging unit are:

- pig
- piggable pipe with piggable valves
- pig loading and unloading station
- propellant supply
- control system.

Figure 4.12 shows the typical characteristics of a pig used for industrial purposes. Pigging can be applied in various locations, e.g:

- between vessels in a production plant
- process plant – tank farm
- tank farm – filling facilities.

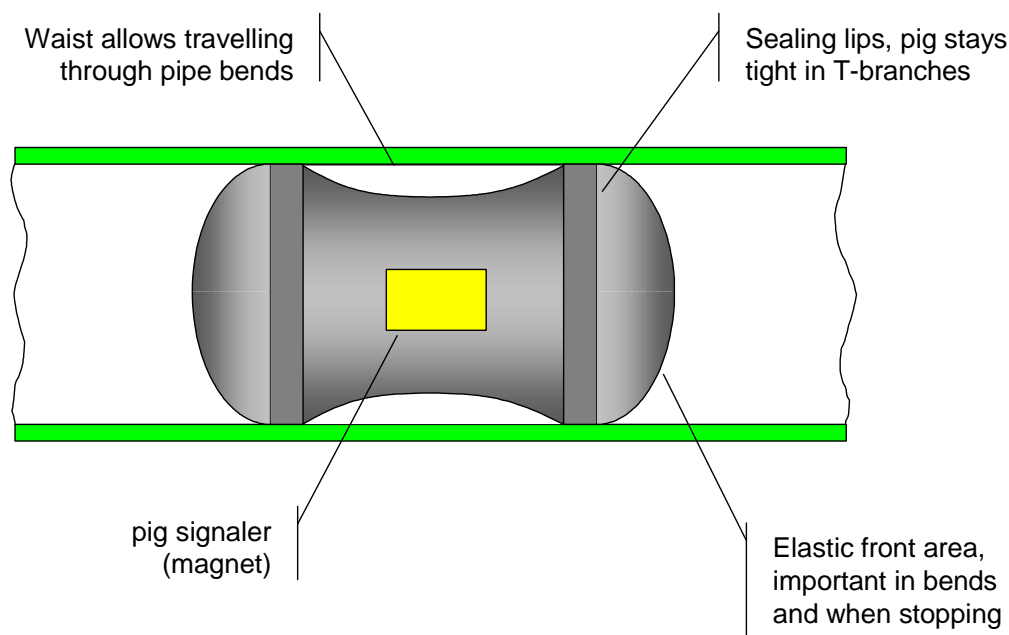

Figure 4.12: Typical characteristics of a pig in a pipe for industrial applications

### Achieved environmental benefits

- no rinsing procedures or substantially reduced amounts of cleaning agents required
- lower load in rinsing waters
- reduced loss of valuable product.

### Cross-media effects

*None believed likely.*

### Operational data

Depends on particular task.

## Applicability

There are a wide range of applications. Especially attractive for long pipelines, multiproduct plants and for batch operation.

Also applicable in sterile plant areas under GMP conditions [41, Hiltcher, 2003]. However, restricted applicability under cGMP conditions is presumed [99, D2 comments, 2005].

Retrofitting may cause higher obstacles due to the requirements for piggable pipes [62, D1 comments, 2004].

Table 4.13 gives some examples for the application of pigging systems.

015D,I,O,B	Dyes
042A,I	Emptying pipes after batches, viscous and unstable intermediates, non cGMP
070X	Speciality surfactants
036L	Dyes, glycols, others
071I,X	Surfactants, products and intermediates in solutions
072X,I	Additives
073F	Flavours, fragrances
074F	Flavours, fragrances
075X,I	Solvents
076X	Speciality surfactants
077X	Speciality surfactants, 80 raw materials and products
078X,I	Amines

**Table 4.13: Examples for the application of pigging systems**

## Economics

Table 4.14 shows an example for the comparison of the costs of a conventional and a pigging pipeline system. The given data indicate a return of investment of 3.7 years.

100 m pipeline, 3 inch				
Conventional	EUR		Pigging system	EUR
Investment costs (10 years service life)				
Pipe material			Pipe material	
Construction			Construction	
Valves, flanges			Valves, flanges, pressure relief vessel	
Total	65000		Total	105000
Yearly operating costs				
Cleaning agent			3 pigs, EUR 250 each maintenance (no rinsing)	
Rinsing once				
Loss of product				
Disposal of lost product and cleaning agent				
Total	14000			3250

**Table 4.14: Comparison of costs for a conventional and pigging pipeline system**



### **Driving force for implementation**

- possible automation, time saving in comparison to manual emptying
- lower costs.

### **References to literature and example plants**

[41, Hiltcher, 2003], for reference plants see information under **Applicability**

## 4.2.9 Indirect cooling

### Description

Cooling can be carried out directly or indirectly. Instead of cooling the vapour phases by the injection (spraying in) of water, cooling can be achieved efficiently by surface heat-exchangers, where the cooling medium (e.g. water, brines, oil) is pumped in a separate circle.

### Achieved environmental benefits

- volume reduction of waste waters
- avoidance of additional waste water streams.

### Cross-media effects

*None believed likely.*

### Operational data

Depends on the particular case.

### Applicability

Widely applicable.

Where processes require the addition of water or ice to enable safe temperature control, temperature jumps or temperature shock, indirect cooling is not possible. An example is the addition of ice in the standard process for the diazotisation of amines (\*004D,O\*). Direct cooling may be also required to control “run away” situations [62, D1 comments, 2004].

Also not applicable where there are concerns about heat-exchangers being blocked [62, D1 comments, 2004].

### Economics

*No information provided.*

### Driving force for implementation

Avoidance of additional waste water streams, and legislation.

### References to literature and example plants

[49, Anhang 22, 2002], \*001A,I\*, \*014V,I\*, \*015D,I,O,B\*

### 4.2.10 Pinch methodology

#### Description

All processes consist of hot and cold streams. A hot stream is defined as one that requires cooling, and a cold stream as one that requires heating. For any process, a single line can be drawn on a temperature-enthalpy plot which represents either all the hot streams or all the cold streams of the process. A single line either representing all the hot streams or all the cold streams is called the hot composite curve or the cold composite curve, respectively. The construction of a composite curve is illustrated in Figure 4.13. Two hot streams are shown on a temperature-enthalpy diagram.

Stream 1 is cooled from 200 to 100 °C. It has a CP (i.e. mass flowrate x specific heat capacity) of 1; therefore, it loses 100 kW of heat. Stream 2 is cooled from 150 to 50 °C. It has a CP of 2; therefore, it loses 200 kW of heat.

The hot composite curve is produced by the simple addition of heat contents over temperature ranges.

Between 200 and 150 °C, only one stream exists and it has a CP of 1. Therefore, the heat loss across that temperature range is 50 kW. Between 150 and 100 °C, two hot streams exist, with a total CP of 3. The total heat loss from 150 to 100 °C is 150 kW. Since the total CP from 150 to 100 °C is greater than the CP from 200 to 150 °C, that portion of the hot composite curve becomes flatter in the second temperature range from 150 to 100 °C.

Between 100 and 50 °C, only one stream exists, with a CP of 2. Therefore, the total heat loss is 100 kW.

Figure 4.14 shows the hot composite curve.

The cold composite curve is constructed in the same way. In practical applications, the number of streams is generally much greater, but these streams are constructed in exactly the same way.

Figure 4.15 shows the hot and cold composite curves plotted on the same temperature-enthalpy diagram. The diagram represents the total heating and cooling requirements of the process.

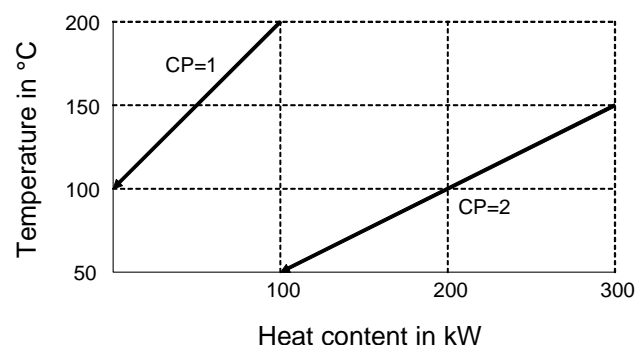

Figure 4.13: Two hot streams

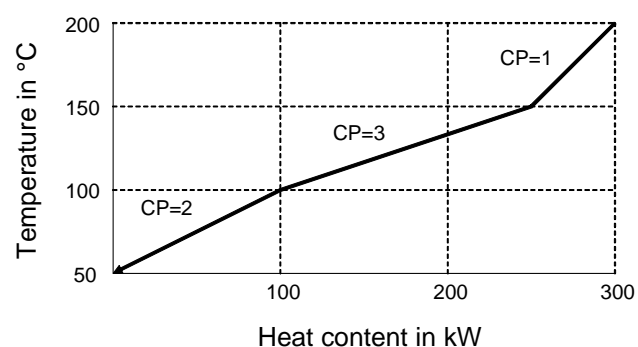

Figure 4.14: Hot composite curve

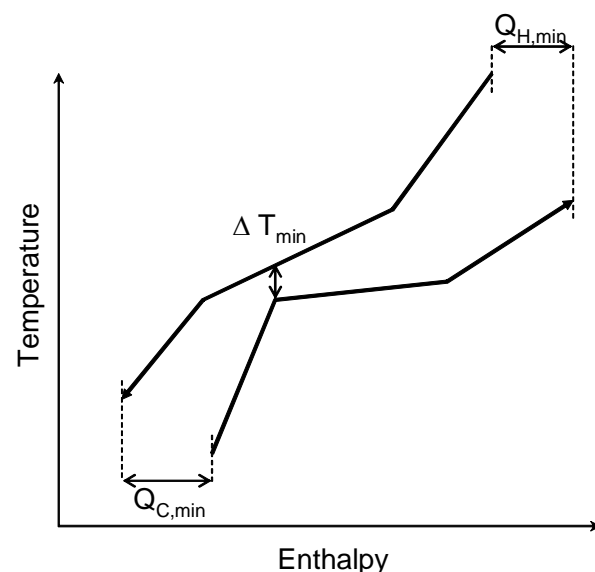
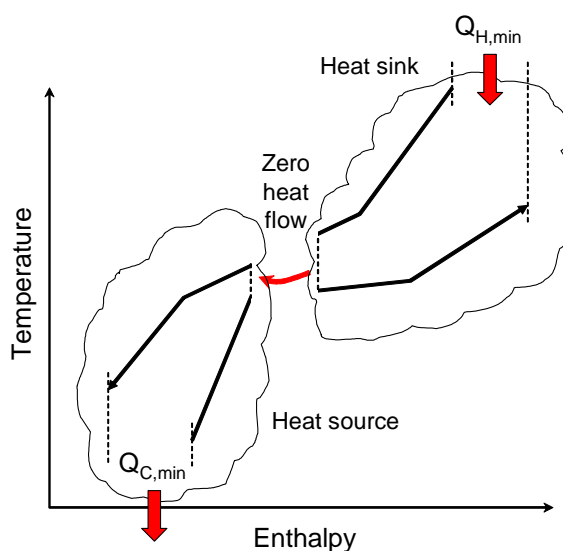

Figure 4.15: Composite curves showing the pinch and energy targets

Along the enthalpy axis, the curves overlap. The hot composite curve can be used to heat up the cold composite curve by process-to-process heat-exchange. However, at either end an overhang exists such that the top of the cold composite curve needs an external heat source ( $Q_{H,min}$ ) and the bottom of the hot composite curve needs external cooling ( $Q_{C,min}$ ). These are known as the hot and cold utility targets.

The point at which the curves come closest to touching is known as the pinch. At the pinch, the curves are separated by the minimum approach temperature  $\Delta T_{min}$ . For that value of  $\Delta T_{min}$ , the region of overlap shows the maximum possible amount of process-to-process heat-exchange. Furthermore,  $Q_{H,min}$  and  $Q_{C,min}$  are the minimum utility requirements.

Once the pinch and utility targets of a process have been identified, the three “golden rules” of pinch methodology can be applied. The process can be considered as two separate systems (see Figure 4.16), a system above the pinch and a system below the pinch. The system above the pinch requires only residual heat and is, therefore, a heat sink, whereas the system below the pinch has heat to reject and is, therefore, a heat source.



**Figure 4.16: Schematic representation of the systems above and below the pinch**

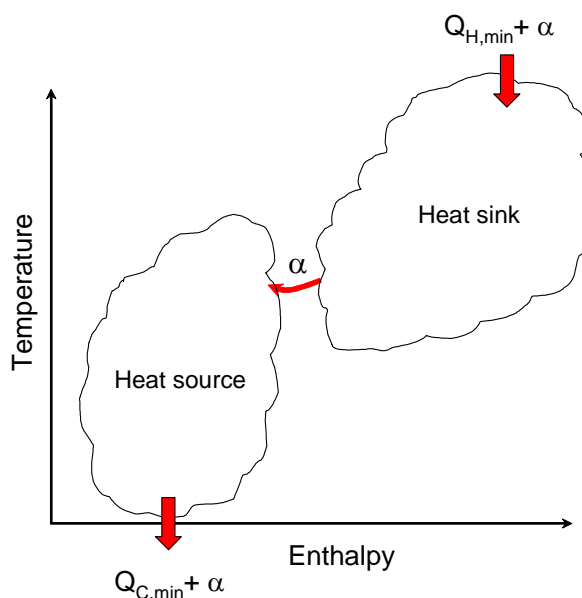

**Figure 4.17: Heat transfer across the pinch from heat sink to heat source**

The three rules are as follows:

- heat must not be transferred across the pinch
- there must be no outside cooling above the pinch
- there must be no outside heating below the pinch.

If the amount of heat travelling across the pinch is  $\alpha$ , then an extra amount ( $\alpha$ ) of hot utility must be supplied and an extra amount of cold utility  $\alpha$  is required (see Figure 4.17). Similarly, any outside cooling of the heat sink and any outside heating of the heat source increases the energy requirements.

Thus:

$$T = A - \alpha$$

where T = target energy consumption  
A = actual energy consumption  
 $\alpha$  = cross-pinch heat flow.

To achieve the energy targets, cross-pinch heat flows must be eliminated.

### **Achieved environmental benefits**

Optimisation of the energy balance on a production site.

### **Cross-media effects**

*None believed likely.*

### **Operational data**

The key to applying Pinch methodology in non-continuous processes is the data extraction. There are no shortcuts; detailed measurements and timings of all the process streams are essential if cost saving (= energy saving) opportunities are to be found.

### **Applicability**

Generally applicable. [6, Ullmann, 2001] reports an example where Pinch methodology was applied to an OFC site operating batch processes with 30 reactors which produces over 300 products.

### **Economics**

Cost benefits. For the example from [6, Ullmann, 2001] savings of EUR 502500 (USD 450000) with payback times of 3 months to 3 years are reported.

### **Driving force for implementation**

Cost benefits.

### **References to literature and example plants**

[6, Ullmann, 2001], [79, Linnhoff, 1987]

### 4.2.11 Energetically coupled distillation

#### Description

If distillation is carried out in two steps (two columns), energy flows in both columns can be coupled. In this example (purification of DMF, see Figure 4.18), the steam from the top of the first column is fed to a heat-exchanger at the base of the second column. Steam usage was reduced by about 50 %. This reduction led to cost savings. As a disadvantage, the energy coupling between the two columns means that variations in the first column affect the process in the second column, which can only be handled by improved process control.

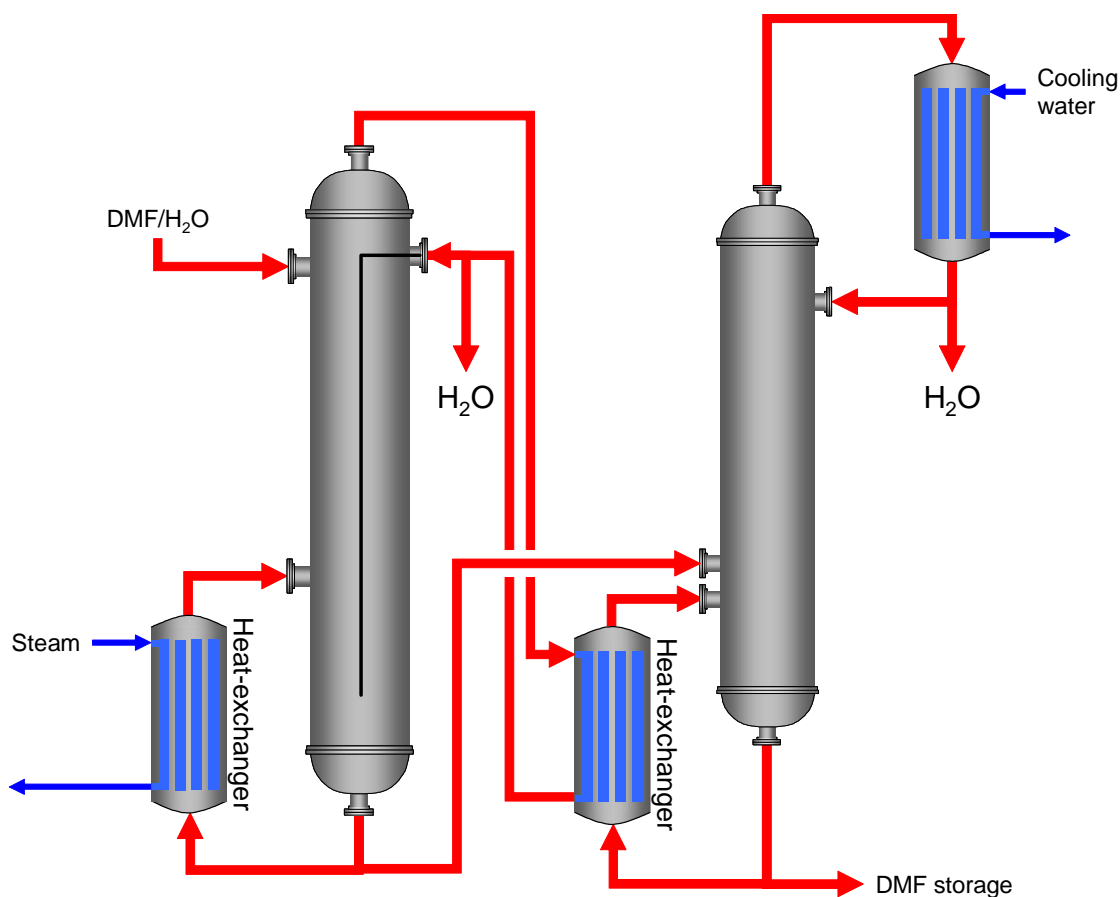

Figure 4.18: Energetically coupled distillation of DMF

#### Achieved environmental benefits

Steam consumption reduced by about 50 %.

#### Cross-media effects

*None believed likely.*

#### Operational data

Depends on the individual case.

#### Applicability

Generally applicable.

**Economics**

Cost benefits.

**Driving force for implementation**

Cost benefits.

**References to literature and example plants**

[9, Christ, 1999]

### 4.2.12 Optimised equipment cleaning (1)

#### Description

Production plant cleaning procedures can be optimised to reduce the resulting waste water loads. In particular the introduction of an additional cleaning step (pre-rinsing) enables the separation of large portions of solvents from wash-waters. The high loaded pre-rinsing stream can be treated subsequently by means of stripping or incineration.

#### Achieved environmental benefits

The avoidance of dilution enables individual and effective recovery/disposal (incineration).

#### Cross-media effects

*None believed likely.*

#### Operational data

Depends on the individual case.

#### Applicability

Generally applicable. Other options for optimised cleaning include [99, D2 comments, 2005]:

- optimised sequence of production
- use of the same cleaning agents/solvents in order to enable recovery
- production of high volume products in dedicated equipment
- re-use of solvent and cleaning liquids.

#### Economics

- higher efficiencies for recovery or disposal
- lower costs for waste water treatment.

#### Driving force for implementation

Cost optimisation.

#### References to literature and example plants

[43, Chimia, 2000]



### 4.2.13 Optimised equipment cleaning (2)

#### Description

Often the cleaning of equipment (e.g. reactors) is finished with a final rinse with solvent. After addition of the solvent (see Section 4.2.18 “Liquid addition into vessels”) the vessel is cleaned by stirring and/or heating. Residual solvent is removed by applying vacuum and/or slightly heating after the emptying of the vessel.

#### Achieved environmental benefits

Prevention of direct VOC releases via openings.

#### Cross-media effects

*None believed likely.*

#### Operational data

*No information provided.*

#### Applicability

Generally applicable.

#### Economics

*No information provided.*

#### Driving force for implementation

*No information provided.*

#### References to literature and example plants

[54, Verfahrens u. Umwelttechnik Kirchner, 2004] \*059B,I\*

#### 4.2.14 Minimisation of VOC emissions (1)

##### Description

- containment and enclosure of sources
- elimination of openings
- use of vapour balancing
- reduction of the use of volatile compounds
- use of products with lower volatilities
- reduction of the operating temperature
- use of closed circuits under a nitrogen atmosphere for drying operations, including condensers for solvent recovery
- use of closed equipment for cleaning
- implementation of a monitoring and maintenance programme.

##### Achieved environmental benefits

- reduction of diffuse/fugitive emissions
- reduction at the source is more effective than recovery or abatement.

##### Cross-media effects

*None believed likely.*

##### Operational data

Negative effects on yields or energy efficiency are possible.

##### Applicability

Generally applicable, effects on yield or energy efficiency have to be considered.

For the production of pharmaceuticals, reduced use of volatile compounds (as mentioned under **Description**) depends on process validation and qualification [62, D1 comments, 2004]. Some practices in the US leak detection and repair programme of the TITLE V clean Air Act would be applicable (e.g. welded flanges rather than screwed flanges) [62, D1 comments, 2004]. Results from leak detection analysis can often not be reproduced [99, D2 comments, 2005].

##### Economics

- investment and maintenance costs, depending heavily on the local situation
- additional purchase costs for fresh solvents and abatement equipment
- beneficial effect on the reliability of the plant.

##### Driving force for implementation

Reduction of diffuse/fugitive emissions, and economics.

##### References to literature and example plants

[37, ESIG, 2003]

## 4.2.15 Minimisation of VOC emissions (2)

### Description

- use of pumps that are designed to be tight, such as canned motor pumps, magnetic drive pumps, pumps with double action mechanical seals and a sealing or locking medium, pumps fitted with double action mechanical seals and seals dry to atmosphere, diaphragm pumps or bellows pumps
- use of multiple sealing systems, if gases or vapours of VOC are compressed. If wet sealing systems are used, the sealing liquid applied on the compressor may not be de-aerated. If dry sealing systems are used, e.g. when feeding inert gas or exhausting the amount of materials to be conveyed leak out, waste gases let out shall be collected and fed to a gas collecting system
- flanged joints shall only be used where they are necessary for reasons regarding process technology, safety or maintenance. In this event, technically tight-flanged joints shall be used (maximum specific leakage ratio amounting to  $10 - 5 \text{ kPa} \cdot \text{l}/(\text{s} \cdot \text{m})$ )
- in order to seal spindle guides of blockage and control devices such as valves or gates, metal bellows with a high grade seal and a downstream safety packing gland or sealing systems of similar effect shall be used (maximum specific leakage ratio amounting to  $10 - 4 \text{ mbar} \cdot \text{l}/(\text{s} \cdot \text{m})$  at temperatures of  $<250 \text{ }^\circ\text{C}$ ; at temperatures  $\geq 250 \text{ }^\circ\text{C}$ :  $10 - 2 \text{ mbar} \cdot \text{l}/(\text{s} \cdot \text{m})$ ). (The specific leakage ratio is detected according to [102, VDI, 2000].)
- application of bottom loading or below surface filling for liquid addition
- waste gases occurring during inspection or while the storage tanks are cleaned shall be fed to a post-combustion system or similar measures shall be applied to reduce emissions
- insofar as storage tanks are set up and operated above ground, the outer wall and the roof shall be covered with suitable paint whose total heat reflection ratio permanently amounts to a minimum of 70 %
- use of technical tight stirring sealing systems like double action mechanical seals and a sealing or locking medium.

### Achieved environmental benefits

- reduction of diffuse/fugitive emissions
- reduction at the source is more effective than recovery or abatement.

### Cross-media effects

*None believed likely.*

### Operational data

*No information provided.*

### Applicability

Generally applicable.

### Economics

- investment and maintenance costs, depending heavily on the local situation
- beneficial effect on the reliability of the plant.

**Driving force for implementation**

Reduction of diffuse/fugitive emissions.

**References to literature and example plants**

[99, D2 comments, 2005], [48, TA Luft, 2002]

## 4.2.16 Airtightness of vessels

### Description

The airtightness of vessels is an important prerequisite for the prevention of fugitive emissions and the reduction of exhaust gas volume flows to recovery or abatement facilities.

To ensure the airtightness of a vessel, all openings are checked (and where necessary sealed) until the vessel keeps an applied pressure or vacuum (e.g. about 100 mbar for at least 30 minutes).

The pressure test is carried out regularly.

### Achieved environmental benefits

- reduction of fugitive emissions
- reduction of exhaust gas volume flows to recovery or abatement techniques
- enables shock inertisation.

### Cross-media effects

*None believed likely.*

### Operational data

*No information provided.*

### Applicability

Generally applicable, also for other types of equipment, e.g. pipes. Also applicable in the case of vacuum distillation.

### Economics

Low costs for implementation. Positive effect on costs for inertisation and recovery or abatement.

### Driving force for implementation

Reduction of fugitive emissions, and reduction of exhaust gas volume flows.

### References to literature and example plants

[54, Verfahrens u. Umwelttechnik Kirchner, 2004] \*042A,I\*, \*059B,I\*

### 4.2.17 Shock inertisation of vessels

#### Description

Inertisation of vessels is carried out in order to keep oxygen levels safely below certain limits. Oxygen (normally air) enters vessels:

- via the additions of liquids, solids, etc.
- via the openings when vacuum is applied
- where contained in the liquids
- or simply if the vessel is opened for cleaning or maintenance.

Inertisation creates an exhaust gas volume flow and the inert gas (nitrogen) can act as a carrier for organic pollutants.

For shock inertisation, the following two steps are carried out until the required oxygen content is achieved:

- (1) application of a vacuum
- (2) flooding with nitrogen.

Shock inertisation is only possible where the airtightness of the equipment can be ensured. Table 4.15 illustrates the different resulting exhaust gas volumes comparing continuous and shock inertisation.

	Shock inertisation	Continuous inertisation
Vessel volume	5 m <sup>3</sup>	
Batch duration	30 hours	
Exchange rate for continuous inertisation		5 m <sup>3</sup> /hour
Number of cycles for shock inertisation	3	
Exhaust gas volume from inertisation	15 m <sup>3</sup>	150 m <sup>3</sup>

Table 4.15: Illustrative example for exhaust gas volumes from inertisation

#### Achieved environmental benefits

- reduction of exhaust gas volume flows to recovery or abatement techniques
- lower consumption of inert gas.

#### Cross-media effects

*None believed likely.*

#### Operational data

*No information provided.*

### **Applicability**

Generally applicable, but only if airtightness of equipment can be ensured. Safety requirements may prevent the application of continuous inertisation, e.g. where processes generate O<sub>2</sub>.

### **Economics**

Positive effect on costs for inertisation and recovery or abatement.

### **Driving force for implementation**

Reduction of exhaust gas volume flows.

### **References to literature and example plants**

[54, Verfahrens u. Umwelttechnik Kirchner, 2004] \*059B,I\*

### 4.2.18 Liquid addition into vessels

#### Description

The addition of a liquid into a vessel leads to the displacement of gases and, therefore, contributes to the exhaust gas volume flow to recovery or abatement techniques. Liquid addition is possible via top feed or via bottom feed or with dip-leg. In the case of an organic liquid the organic load in the displaced gas is about 10 to 100 times higher if added via top feed.

If both solids and an organic liquids are added to the vessel, the solids can be used as a dynamic lid in case of bottom feeding of the liquid, which has also a positive effect on the organic load of the displaced gas.

#### Achieved environmental benefits

Lower loads of pollutant in displaced gases arising from the addition of liquids.

#### Cross-media effects

*None believed likely.*

#### Operational data

*No information provided.*

#### Applicability

Widely applicable, but restrictions occur due to safety or quality concerns. Alternatively, but with similar restrictions, gas-balancing can be used [99, D2 comments, 2005].

#### Economics

Low costs for implementation. Positive effect on costs for recovery or abatement.

#### Driving force for implementation

Costs for recovery and abatement.

#### References to literature and example plants

[54, Verfahrens u. Umwelttechnik Kirchner, 2004] \*059B,I\*



## 4.2.19 Solid-liquid separation in closed systems

### Description

A very frequent task on an OFC site is the separation of a solid product or intermediate from a liquid (usually the solvent) by filtration. Diffuse VOC emissions occur when the equipment is opened to discharge the wet filter cake for further processing or drying. This can be avoided by applying, e.g. one of the following options:

Nutsche type pressure filter	Nutsche type filter dryer
<ul style="list-style-type: none"> <li>removal of the wet cake from the filter with a hydraulic system as far as possible</li> <li>recycling of the remaining product with the next batch by dissolving it again or simply leaving it in the filter</li> <li>the equipment remains closed.</li> </ul>	<ul style="list-style-type: none"> <li>drying the cake (vacuum and heated equipment)</li> <li>removal of the dry product with a hydraulic system</li> <li>blowing out the remaining product with N<sub>2</sub> and recovery of the product with a cyclone</li> <li>the equipment remains closed.</li> </ul>

### Achieved environmental benefits

Minimisation of diffuse emissions.

### Cross-media effects

*None believed likely.*

### Operational data

*No information provided.*

### Applicability

Generally applicable. Pressure Nutsche filters are successfully utilised in the petrochemical, inorganic and organic chemical, fine chemical and especially the pharmaceutical industries including operation under cGMP conditions. Suitable equipment is available for almost any solid-liquid separation problem, for continuous, semi-continuous or discontinuous operation, each available with a wide variety of suitable designs.

Solid-liquid separation is also carried out with centrifuges, keeping the system closed for subsequent operations [99, D2 comments, 2005].

### Economics

Costs for retrofitting.

### Driving force for implementation

Minimisation of diffuse emissions.

### References to literature and example plants

[89, 3V Green Eagle, 2004], [91, Serr, 2004], \*088I,X\*

### 4.2.20 Minimisation of exhaust gas volume flows from distillation

#### Description

Exhaust gas volume flows from distillation can be minimised to practically zero if the layout of the condenser allows sufficient heat removal. Figure 4.19 shows an example for the separation of a mixture of ethanol/diethylether/water. The first column separates the diethylether from water and ethanol, the second column leads to a top product containing about 94 % ethanol and about 6 % water and water as bottom product. Condensation is carried out with water cooled condensers (10 – 12 °C).

Energy consumption is optimised by heat-exchange between bottom output and feed.

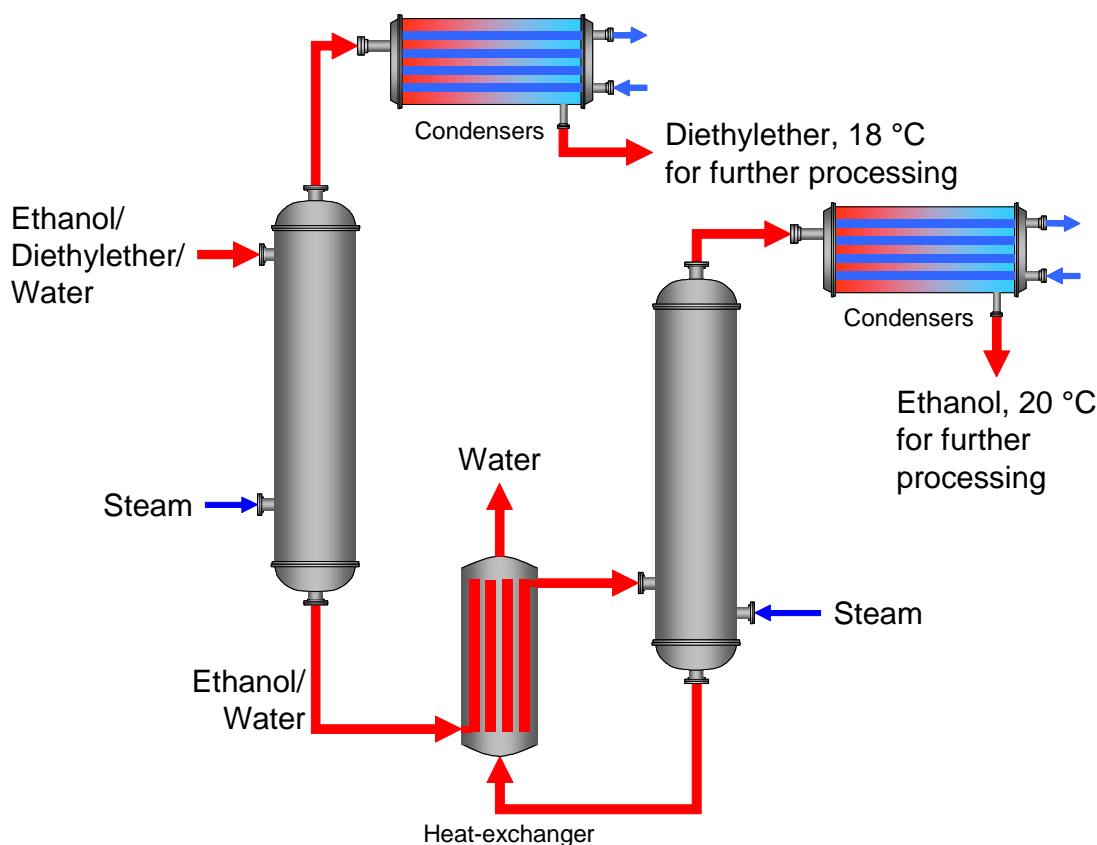

Figure 4.19: Example for a closed distillation system

#### Achieved environmental benefits

- prevention of VOC emissions from distillations
- relief of abatement systems.

#### Cross-media effects

*None believed likely.*

#### Operational data

Example from \*062E\*:

- heating: steam
- feed: 460 kg/hour
- equipment for emergency pressure relief.

### **Applicability**

Generally applicable.

If non-condensable gases are dissolved in the input to the distillation (e.g. inert gases), measures have to be taken to cope with the added volume in the start-up phase of the distillation.

Similarly applicable to the recrystallisation from organic solvents (\*064E\*).

### **Economics**

No significant additional costs in comparison to vented systems.

### **Driving force for implementation**

Costs benefits.

### **References to literature and example plants**

[54, Verfahrens u. Umwelttechnik Kirchner, 2004], \*062E\*

### 4.2.21 Segregation of waste water streams

#### Description

Strategies for the management of waste water streams on a multipurpose site are ineffective if it cannot be ensured that segregation of waste water streams to different destinations can be carried out in reality. Within the manufacture of a single product and even more taking into account different production campaigns, the destination of the created waste water stream may change frequently, e.g:

Product 1	Mother liquor	Wet oxidation
	1. Wash-water	Biological WWTP
	2. Wash-water	Biological WWTP
End of campaign	Rinsing water	Biological WWTP
Product 2	Mother liquor 1	Extraction
	Mother liquor 2	Wet oxidation
	Wash-water	Biological WWTP

On the \*015D,I,O,B\* site, the typical origins of waste water streams are the components for liquid-solid separation (filter presses, other filters). All such equipment is connected to the four main destinations for waste water streams: biological WWTP and pretreatment facilities (Figure 4.20).

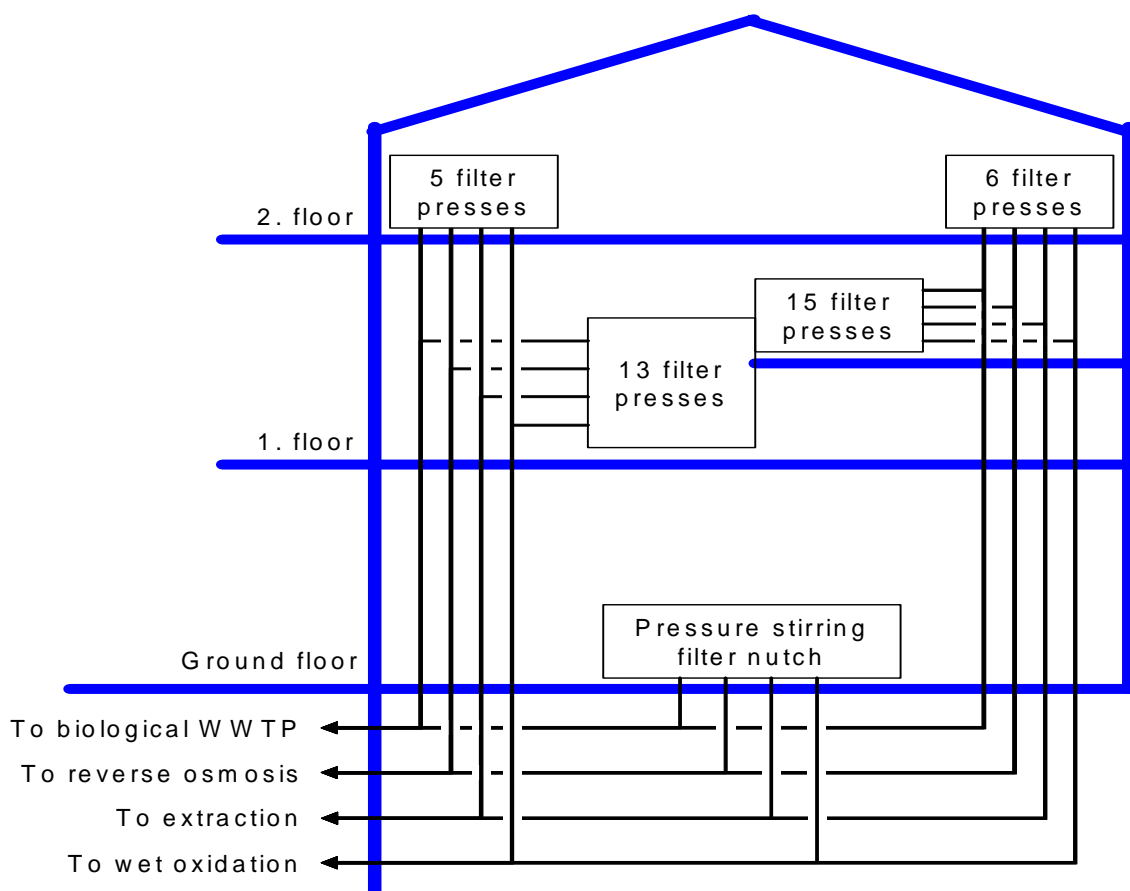

Figure 4.20: Segregation of waste water streams from a production building

**Achieved environmental benefits**

Enables operators to realise management of waste water streams.

**Cross-media effects**

*None believed likely.*

**Operational data**

*No information provided.*

**Applicability**

Generally applicable.

Similar example: \*068B,D,I\*

**Economics**

Cost for pipes, instrumentation, controls, automated valves, etc.

**Driving force for implementation**

Realisation of a management strategy.

**References to literature and example plants**

[31, European Commission, 2003], \*015D,I,O,B\*

### 4.2.22 Countercurrent product washing

#### Description

As a polishing step, organic products are often washed with an aqueous phase in order to remove impurities. High efficiencies in combination with low water consumption (and low waste water generation) can be achieved with countercurrent washing, which may be also combined with other purification steps. Figure 4.21 shows countercurrent product washing in the manufacture of trinitro toluene (TNT). The additional purification step removes non-symmetrical TNTs by adding sodium sulphite and removal of the so-called “red water”.

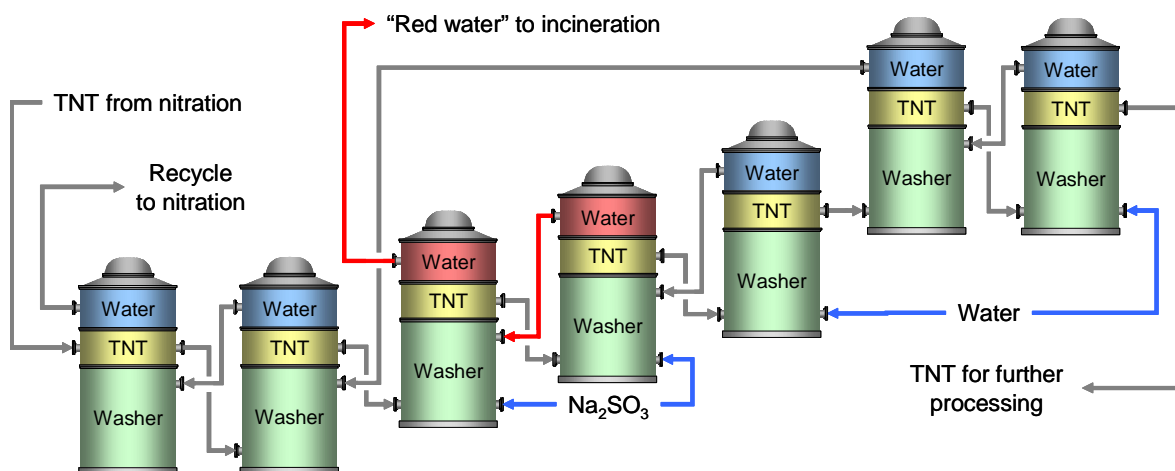

Figure 4.21: Countercurrent product washing in the manufacture of TNT

#### Achieved environmental benefits

- lower water consumption
- less waste water is created
- allows recycling or individual treatment of portions of particular contents or concentrations.

#### Cross-media effects

*None believed likely.*

#### Operational data

*No information provided.*

#### Applicability

Widely applicable.

The degree of optimisation of the washing process depends on the production level and regularity. Therefore, countercurrent washing is especially economic in larger scale plants, since it can be tailored specifically to a production process. With small amounts, experimental production runs, short or rare production campaigns, these processes cannot be used [62, D1 comments, 2004].

**Economics**

Cost benefits.

**Driving force for implementation**

Cost benefits, and water consumption.

**References to literature and example plants**

[91, Serr, 2004], \*062E\*, \*064E\*

### 4.2.23 Example for reaction control: azo coupling

#### Description

An azo coupling batch may be completed immediately after the components are mixed or after several hours. In order to check whether excess diazonium compound is still present, a drop of reaction solution is spotted onto filter paper together with a component that couples easily (e.g. weakly alkaline H acid solution). If no colouration appears, the coupling is completed. The presence of unconsumed coupling component can be determined by spotting with a diazonium salt solution.

#### Achieved environmental benefits

- reduction of the COD load of the resulting mother liquor
- more effective use of starting materials.

#### Cross-media effects

*None believed likely.*

#### Operational data

*No information provided.*

#### Applicability

Analogously applicable to a wide range of processes, especially in cases when quantitative conversion is possible (e.g. coupling or addition reactions).

#### Economics

- higher yields
- lower waste water treatment costs.

#### Driving force for implementation

Economics.

#### References to literature and example plants

\*004D,O\*



#### 4.2.24 Avoidance of mother liquors with high salt contents

##### Description

Product separation by salting out or bulk neutralisation (e.g. addition of alkali or “liming” or “chalking”) should be avoided, since the work-up of the resulting mother liquors (often containing high organic loadings) is often limited by the salt content. Examples are spent acids from sulphonations or nitrations, which could be recycled in a sulphuric acid plant, if the salt content was not too high.

Alternative techniques include, e.g:

- membrane processes (see Section 4.2.26)
- solvent based processes
- reactive extraction (see Section 4.2.25)
- omission of intermediate isolation (see Section 4.2.4).

An example for the change to a solvent-based process is given in [9, Christ, 1999] and illustrated in Table 4.16.

[9, Christ, 1999]	<b>Former process</b>	<b>New process</b>
	Reaction in H <sub>2</sub> SO <sub>4</sub>	<i>Solvent based</i>
<b>Precipitation induced by</b>	Salting out	pH adjustment and vacuum cooling
<b>Recovery of the H<sub>2</sub>SO<sub>4</sub> possible?</b>	No	Yes
<b>Mother liquor to biological WWTP?</b>	Yes COD 3000 t/yr Poorly degradable	No

**Table 4.16: Process modification to avoid salting out**

##### Achieved environmental benefits

- enables the work-up of mother liquors and especially recovery of spent H<sub>2</sub>SO<sub>4</sub>
- reduced organic load in the waste water.

##### Cross-media effects

VOC emissions and additional energy/chemicals consumption for recovery/abatement in case of change to a solvent-based process.

##### Operational data

Depends on the alternative separation technique/alternative process.

##### Applicability

Depends on the options to alter the causing process.

### **Economics**

Depends on the particular alternatives, e.g:

- high costs if complete processes have to be replaced or new recovery/abatement techniques have to be established because of the change to a solvent-based process
- economic benefits if alternative separation techniques increase the yield and optimise the disposal costs.

### **Driving force for implementation**

- high organic waste water loads
- additional disposal costs.

### **References to literature and example plants**

[15, Köppke, 2000], [9, Christ, 1999]

## 4.2.25 Reactive extraction

### Description

Organic acids can be selectively extracted from aqueous solutions after pH adjustment with a suitable organic base dissolved in hydrocarbons. The base is usually a tertiary amine (e.g. ®Hostarex A327). The acid and base form a stable complex compound in the organic phase. After phase separation, the complex is split by the addition of aqueous NaOH and the acid can be obtained as a sodium salt. The base and hydrocarbons are used in a closed cycle.

### Achieved environmental benefits

- recovery of valuable raw material or product
- reduction of organic waste water load.

### Cross-media effects

*None believed likely.*

### Operational data

Depends on the separation target.

### Applicability

General procedure possible for organic bases.

Other applications [6, Ullmann, 2001]:

- phenols and bisphenols with 5 % trioctyl amine in Shellsol AB
- mercapto benzo thiazol with 20 % trioctyl amine in Shellsol AB
- metal cations with classical complexing/chelating agents.

### Economics

- lucrative if the recovered raw material or product is pure enough for further processing
- reduced waste water treatment costs.

### Driving force for implementation

- recovery of raw material or product
- reduction of waste water treatment costs
- reduction of waste water charges [62, D1 comments, 2004].

### References to literature and example plants

[6, Ullmann, 2001, 9, Christ, 1999, 33, DECHEMA, 1995] and references within

### 4.2.26 Use of pressure permeation in dye manufacture

#### Description

In the production of water soluble dyes, separation of the product is usually carried out by salting out, filtering, re-dissolving or re-suspending and re-filtering and drying. In this process, mother liquors with high COD and salt loads are produced. Pressure permeation (see Figure 4.22) can replace these steps and leads to higher yields and reduced waste streams.

Pressure permeation plants use semi-permeable membranes that are permeable to water, inorganic salts and small organic molecules, but quantitatively retain dyes in solution. The synthesis solution containing salt passes from the reaction vessel into a holding tank and subsequently through the membranes under pressure. There, it is separated into a salt-containing and almost dye-free permeate and the dye concentrate. The dye concentrate is recycled to the holding tank.

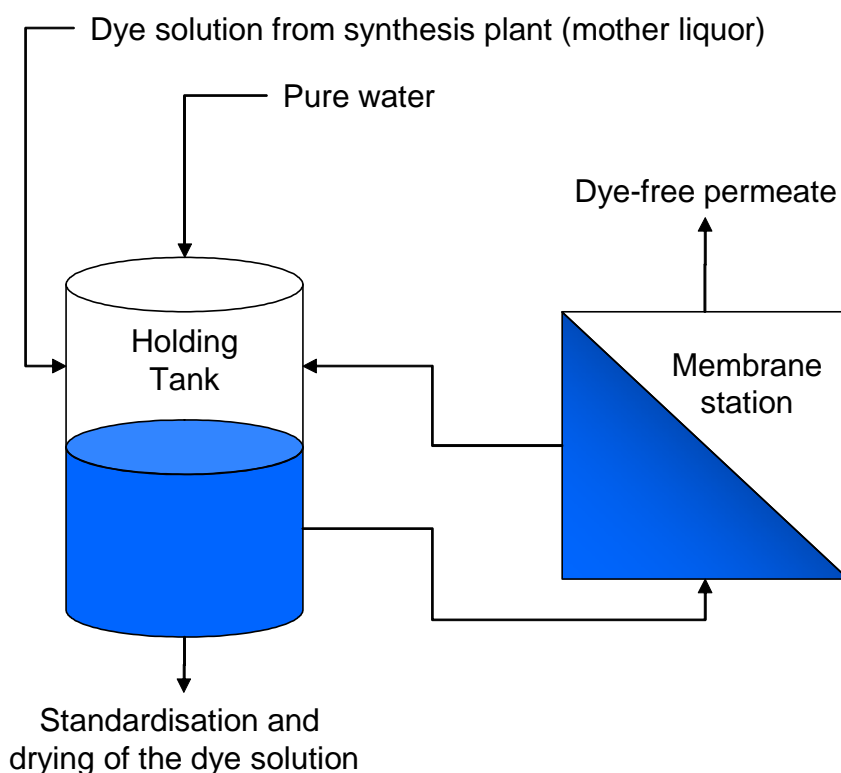

Figure 4.22: Product separation using pressure permeation

#### Achieved environmental benefits

Table 4.17 shows the main environmental benefits in comparison to the conventional product work-up.

		Conventional process	With pressure permeation
Produced dye		1 tonne	1 tonne
Waste water streams	Quantity	7.0 tonnes	-90 %
	Salt load	1.5 tonnes	-90 %
	COD	50 kg	-80 %

Table 4.17: Environmental benefits of product separation by pressure permeation

### **Cross-media effects**

No shifts to other environmental media are reported. Due to the replacement of a conventional process with several steps to a one step process, energy consumption is not expected to increase.

### **Operational data**

According to the separation requirements, microfiltration, ultrafiltration, nanofiltration or reverse osmosis setups are used. The membrane surfaces are in the shape of spirally wound, plate-shaped or tubular modules. The operating pressure and throughput depend on the membrane characteristics and the separation task.

### **Applicability**

Pressure permeation is not restricted to the manufacture of water soluble dyes but, in principle, applicable for a wide range of separation tasks. Important pre-conditions in particular cases are:

- both suitable and reliable membranes need to be available
- satisfactory product quality can be reached.

Other examples:

- separation of a tertiary amine (product) from waste water streams by reverse osmosis. Recovered product and reduced waste water costs lead to very fast paybacks (\*007I\*)
- separation of fermentation products by ultrafiltration [46, Ministerio de Medio Ambiente, 2003].

### **Economics**

The economic advantages are:

- reduced waste water costs
- equal or sometimes enhanced product quality
- up to 5 % higher yields
- costs for standardisation auxiliaries can be saved.

### **Driving force for implementation**

Reduction of waste water loads, yield optimisation, and cost benefits.

### **References to literature and example plants**

[9, Christ, 1999], [61, Martin, 2002], \*060D,I\*, \*004D,O\*, \*007I\* and references within.

### 4.2.27 Ground protection

#### Description

Facilities, where substances (usually liquids) which represent a potential risk of contamination of ground and groundwater are handled, have to be built, operated and maintained in such a way that spill potential is minimised. They have to be sealed, stable and sufficiently resistant against possible mechanical, thermal or chemical stress. Leakages have to be quickly and reliably recognisable. Leaking substances have to be safely retained and treated/disposed of. This is realised by applying an impervious and stable retention area according to the amount of substance that could be spilled before other measures take effect. Alternatively double walled equipment with leak detection can be used.

#### Achieved environmental benefits

Prevention of ground, surface and groundwater contamination.

#### Cross-media effects

*None believed likely.*

#### Operational data

Measures for ground protection depend on the hazard arising from a handled substance in the case of contamination of ground, surfacewater or groundwater.

Measures include:

- providing sufficient retention volumes based on the largest tank or drum, or the capacity of multiple tanks if they are interconnected by piping at the bottom
- testing and demonstration of the integrity and tightness of all bunding structures and their resistance to penetration by water or other substances
- loading and unloading of materials only on designated areas protected against leakage run-off
- storage and collection of materials awaiting disposal on designated areas protected against leakage run-off
- designing facilities so that they can be visually inspected
- fitting all pump sumps or other treatment plant chambers from which spillage might occur with high liquid level alarms or, alternatively, regularly supervise pump sumps by personnel
- equipping tanks with overflow controllers
- programmes of testing and inspecting of tanks and pipelines
- inspecting for leaks on flanges and valves on pipes used to transport materials other than water (e.g. visual inspection or testing with water). Maintaining a log of these inspections
- catchment systems to collect leaks from flanges and valves on pipes used to transport materials other than water
- supplying of containment booms and suitable absorbent material.

#### Applicability

Generally applicable.

Formal inspections are unnecessary where pipework is within a bunded area and release will not result in a hazard [62, D1 comments, 2004].

For ground protection in the case of storage facilities, see [64, European Commission, 2005].

**Economics**

*No information provided.*

**Driving force for implementation**

Prevention of ground, surface and groundwater contamination.

**References to literature and example plants**

\*019A,I\*, \*020A,I\*, \*001A,I\*, \*014V,I\*, \*015D,I,O,B\*

#### 4.2.28 Retention of fire fighting and contaminated surface water

##### Description

Fire fighting water or contaminated surface water is collected from the surface water system and stored in a pond designed to contain the maximum fire water discharge on site plus a certain quantity of rainwater at the same time. The contained liquid may be pumped to the WWTP at a controlled rate, as required.

##### Achieved environmental benefits

Prevention of ground, surface and groundwater contamination.

##### Cross-media effects

*None believed likely.*

##### Operational data

The retention volume depends on the quantity and properties of the stored/handled materials, and takes into account, for example a 24 hours 50 mm rainfall.

Usually with online monitoring including automatic valve action at TOC = 20 mg/l.

##### Applicability

Generally applicable.

Spatial restrictions on existing sites can represent a serious obstacle [99, D2 comments, 2005].

The waste water pipe system can also be used as retention volume [99, D2 comments, 2005].

##### Economics

*No information provided.*

##### Driving force for implementation

Prevention of ground, surface and groundwater contamination.

##### References to literature and example plants

\*017A,I\*, \*018A,I\*, \*019A,I\*, \*020A,I\*



## 4.2.29 Example: training of phosgenation operators

### Description

The handling of toxic substances demands sufficient and adequate knowledge from an operator to work safely in normal operation and to react adequately when deviations from normal operations occur. Therefore training of an operator who is working with phosgene includes:

### *Theoretical background*

- information on phosgene (e.g. toxicology, physical and chemical properties)
- information on the phosgenation process
- storage and piping
- working knowledge of the detection and emergency systems
- abatement in scrubbers
- transfer and neutralisation of solvents containing phosgene
- sample taking
- intoxication with phosgene
- emergency plan
- personal protection equipment.

### *Practical training*

- operation and control of the scrubbers
- checking, activation and shutdown of safety devices
- checking, activation and shutdown, filling and emptying of the condensers
- installation and removal of the phosgene cylinders, activation of the heating
- balancing of phosgene consumption
- sample taking
- control of the phosgenation
- degassing and neutralisation
- cooling system
- phosgene testing
- fittings for phosgene handling
- connecting pipes
- intervention and actions in case of deviations.

### **Achieved environmental benefits**

Limitation of risks from the storage and handling of phosgene.

### **Cross-media effects**

*None believed likely.*

### **Operational data**

*No information provided.*

### **Applicability**

Generally applicable for the handling of hazardous substances or other hazardous operations [62, D1 comments, 2004]. Individual substance properties and conditions may require modified training contents.

### **Economics**

Additional costs related to training, i.e. time, materials.

### **Driving force for implementation**

Limitation of risks from the storage and handling of phosgene.

### **References to literature and example plants**

\*024A,I\*

### 4.2.30 Example: Handling of phosgene

#### Description

Due to the high toxicity of phosgene precautions need to be taken to limit the risks arising from storage and handling. These include the measures given in Table 4.18 (next page).

#### Achieved environmental benefits

Limitation of risks from the storage and handling of phosgene.

#### Cross-media effects

*None believed likely.*

#### Operational data

*No information provided.*

#### Applicability

Generally applicable for the handling and storage of toxic substances (e.g. Cl<sub>2</sub>, gaseous ammonia, EtO, etc.). Individual substance properties and conditions may require modified measures.

#### Economics

Higher costs in comparison to a conventional setup/conventional operation.

#### Driving force for implementation

Limitation of risks from the storage and handling of phosgene.

#### References to literature and example plants

[116, Phosgene Panel, 2005], \*024A,I\*

Measure	Remarks [99, D2 comments, 2005]
Applying separate areas for phosgene storage, the phosgenation process and for abatement	The optimum depends on the size: the bigger the unit, the longer the ways between the sections and the more it may be appropriate to combine and concentrate sections
Minimisation of the stored amount	Absolutely correct; however it may be the case – especially while recovering phosgene from the process – that phosgene storage has to be increased in order to minimise the phosgene inventory of the whole system
Applying divisions in the storage units (i.e. five gas cylinders for 48 kg phosgene)	Depending on size of the cylinders (the given example does not necessarily describe standard cylinders) and the total amount of phosgene compartments/divisions might have disadvantages (e.g. it is more difficult to search leakages)
Ensuring each storage unit is weighable for balancing	Applicable if phosgene is supplied by cylinders
Applying double walled pipes to the reactors equipped with phosgene detection	Despite increased and more difficult maintenance efforts, double walled constructions can be the method of choice to protect critical areas in phosgenation units
Using glove box setup for the storage	Another method to avoid phosgene contact in the case of leakage would be to use fresh air mask equipment
Placing the reactors in a separate cabin, and then making access open only with full protective clothing and equipment	Opening equipment containing phosgene has to be avoided. Separate cabins can be part of a general policy of structural enclosures. The layout depends on the amount of phosgene and/or the overall phosgene safety system and strategy
Just using closed equipment	
Making valves redundant, including automatic action based on phosgene detection	Other companies have had bad experiences with redundancies which seem to fail in case of emergencies: they tend to carry out more tests and inspections to guarantee proper function. Similar problems have to be considered for automatic action
Applying a pressure check with nitrogen before starting the process	
Applying redundant and independent detection networks	This is dependent on the size and complexity of the unit: too many redundancies may cause problems (automatic or human) in judging on contradicting information. Some companies do not like redundancies in the meaning of different detection systems, they prefer to stay with the one that is best known and most reliable. Some companies have good experience with detection networks, bigger plants often do not like increased retention times and prefer (critical) spot detection
Exhausting the process, e.g. via condensers (+5, -30 and -60 °C) and two scrubbers	The temperatures to be applied are dependent on the pressure under which the system is operated
Exhausting the room air via a scrubber	Not applicable for open structure plants. If (depending, e.g. on the use of personal safety equipment) the total safety system allows considerable amounts of phosgene to be emitted into the room air (see, e.g. opening of reactors) then the possibility of exhausting the room air should be considered. In other cases, the need has to be assessed case by case
Having an ammonia gas supply for emergency situations	Ammonia is a very effective neutralising agent for phosgene; however, its application requires careful consideration of the situation (e.g. in structural enclosures)
Applying special training for the operators	
Enforcing stringent work procedures	

Table 4.18: Measures to limit the risks arising from storage and handling of phosgene

### 4.3 Management and treatment of waste streams

#### The interface to the BREF on CWW [31, European Commission, 2003]

The BREF on “Common waste gas and waste water treatment/management systems in the chemical sector” describes techniques which are commonly applicable in the whole spectrum of the chemical industry. As a result, only generic conclusions were derived, which de facto could not take into account the specific characteristics of the manufacture of Organic Fine Chemicals.

Using the results from the BREF on CWW as a source of information, the BREF on OFC provides a further assessment of such techniques in the OFC context. The main aspect is the effect of the operational mode (batch manufacture, production campaigns, frequent product change) on the selection and the applicability of treatment techniques, as well as the implicit challenges of managing a multipurpose site. Furthermore the performance is assessed and conclusions are drawn based on OFC specific information and data.

Recovery and abatement techniques are not described in detail in the following sections again. Where more information is needed, please refer to the BREF on CWW [31, European Commission, 2003].

## 4.3.1 Balances and monitoring

## 4.3.1.1 Process waste stream analysis

## Description

On a multipurpose site (see Section 2.2), pollution prevention and control is possible only if the waste streams from each process are first identified and characterised. Process waste stream analysis is based on flow charts, illustrating the operations, inputs and waste streams. A second supporting chart would give the relevant data for each waste stream.

Table 4.19 and Table 4.20 illustrate one possible method (the example has been modified due to confidentiality reasons).

Process waste stream analysis:	Flow chart	
Batch bromination of example acid		
		
Input	Operations	Waste stream Stream ID Destination Sample ID
		Exhaust from Sc-01 Sc-01a To main scrubber
180 kg example acid 200 kg ice 300 kg NaCl 65.5 kg Br <sub>2</sub> 300 litre HCl 2100 litre water		Bromine in water Sc-01b To recovery 129
6300 litre salt water		Mother liquor F-01a To low pressure wet oxidation 181
		Wash-water F-01b To WWTP 198

Table 4.19: Process waste stream analysis, flow chart

Process waste stream analysis				Aqueous streams								
Waste stream	Stream ID	Sample ID	Content	Degradability	Toxicity to nitrification	Dilution factor*	Litres per batch	Batches per year	Loading per batch in kg			
				<i>COD reduction</i>					<i>COD</i>	<i>BOD</i>	<i>AOX</i>	
Bromine in water	Sc01a	129	15 kg bromine				1000					
Mother liquor	F01a	181	26 kg lost starting material, NaCl, HCl, HBr	35 %		770	2600	130	35			
Wash-water	F01b	198	Lost product	40 %		317	6300	130	1.5			
												* Dilution after mixing with the total effluent of 2000 m <sup>3</sup> .

Table 4.20: Process waste stream analysis, properties of the waste water streams

### **Achieved environmental benefits**

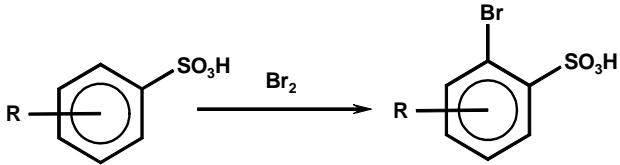
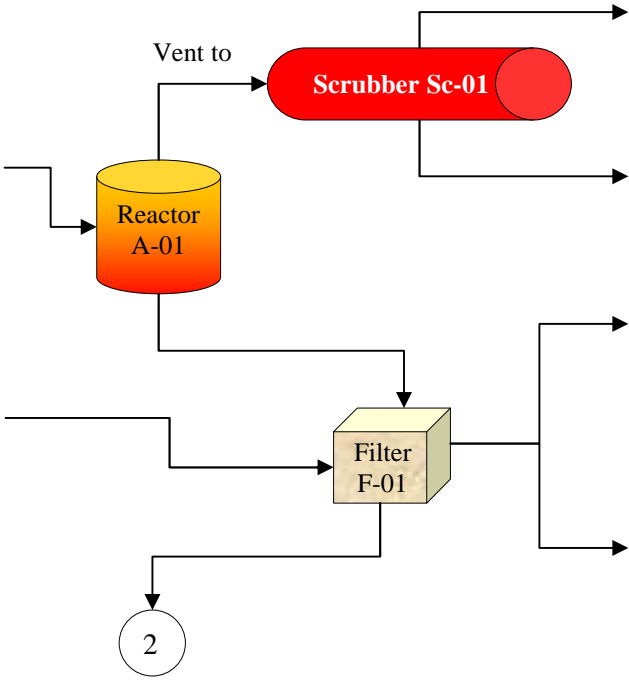
Process waste stream analysis provides:

- clear identification and characterisation of the individual waste stream
- a basis for decisions on the waste stream's further destination
- key information for improvement strategies.

### **Cross-media effects**

*None believed likely.*

### **Operational data**

*No information provided.*

### **Applicability**

Generally applicable.

### **Economics**

*No information provided.*

### **Driving force for implementation**

Central part of process design or process review, and also part of the emission inventory.

### **References to literature and example plants**

\*006A,I\*, \*017A,I\*, \*018A,I\*



### 4.3.1.2 Analysis of waste water streams

#### Description

On an OFC site, a wide variety of different waste water streams are created. Knowledge of a basic set of parameters of such waste water streams is created once (presuming that all batches of the same production step continually create the same waste water stream) and represents the basis for segregation and pretreatment strategies. Table 4.21 shows an example of such a basic data set.

Waste water stream			
Batches per day	1	Volume per batch	3100 litres
Batches in 1999	47	Volume in 1999	145700 litres
Parameter	Level	Load per day	Load per year
COD	20000 mg/l	62.0 kg	2.9 tonnes
BOD <sub>5</sub>	4400 mg/l	13.6 kg	641 kg
TOC	1600 mg/l	5.0 kg	234 kg
AOX	217 mg/l	673 g	31 kg
Total N	300 mg/l	0.8 kg	39 kg
Total P	None		
Heavy metals	Cr	None	
	Ni	None	
	Cu	None	
	Zn	None	
Chloride	27200 mg/l	84.3 kg	4.0 tonnes
Bromide	103000 mg/l	319 kg	15 tonnes
SO <sub>4</sub> <sup>2-</sup>	None		
pH	1.0	COD/BOD <sub>5</sub> = 4.5	
Toxicity	None		
Bioeliminability	75 % elimination (Zahn-Wellens), see attachment		
Inhibition of nitrification	No influence on nitrification		
<b>Result</b>	Readily biodegradable and does not inhibit nitrification. AOX pretreatment required.		

**Table 4.21: Example for an analysis of a waste water stream from a multipurpose plant**

#### Achieved environmental benefits

Creating the basic data set to enable segregation and pretreatment.

#### Cross-media effects

*None believed likely.*

#### Operational data

*No information provided.*

### **Applicability**

Generally applicable.

### **Economics**

Costs for testing.

### **Driving force for implementation**

Basic requirement for waste water management.

### **References to literature and example plants**

[84, Meyer, 2004]

### 4.3.1.3 Refractory organic loading: Zahn-Wellens test

#### Description

The purpose of this test method is the evaluation of the elimination of organic substances when exposed to relatively high concentrations of micro-organisms (activated sludge) in a static test. The test may be conducted using activated sludge that has previously been exposed to the test substance (especially from the onsite biological WWTP), which frequently results in adaptation leading to a significantly more extensive degradation of the organic substance. DOC (or COD) values are measured and compared to a blank test setup. The observed DOC (or COD) elimination gives a proven measure of the bioeliminability. If the oxygen uptake is also measured, the test can allow also a differentiation between true degradation, adsorption and stripping effects and also gives information on the inhibiting or adaptation effects of the test substance.

#### Achieved environmental benefits

The Zahn-Wellens test:

- provides information about bioeliminability and biodegradability
- provides highly meaningful information on the behaviour of a substance under biological treatment conditions
- provides more useful information than is possible from just determining the BOD<sub>5</sub>/TOC ratio. Figure 4.23 shows that the BOD<sub>5</sub>/TOC ratio may lead to different, even incorrect conclusions when indicating low biodegradability
- is an important information source for informed decisions on the further treatment of waste water streams.

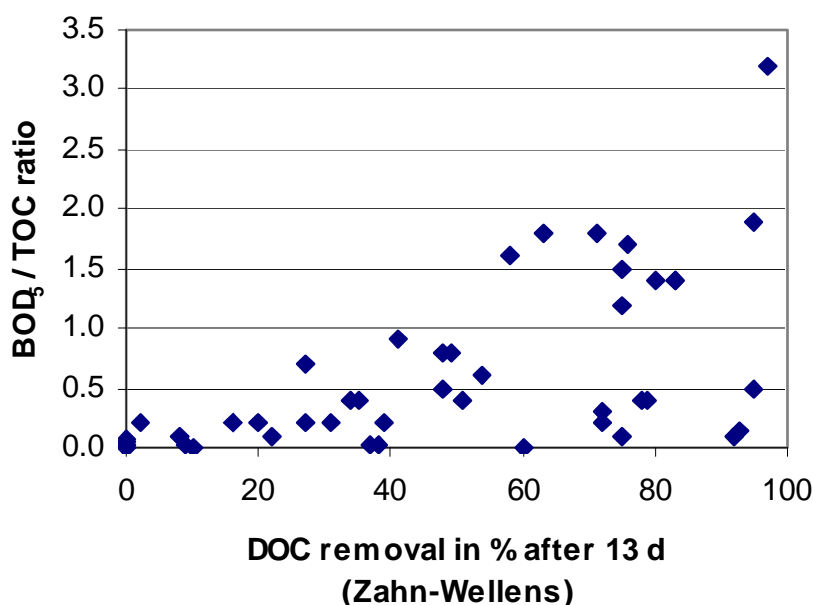

Figure 4.23: Comparison of BOD<sub>5</sub>/TOC ratio and Zahn-Wellens tests on mother liquors

#### Cross-media effects

*None believed likely.*

### **Operational data**

*No information provided.*

### **Applicability**

Test substances should:

- be soluble in water under the test conditions
- have negligible vapour pressure under the test conditions
- be non-inhibitory to bacteria at test concentrations
- be adsorbed within the test system only to a limited extent
- be not lost by foaming from the test solution.

Generally applicable. The Zahn-Wellens test is generally applicable and is a common and proven method to determine the refractory organic carbon (ROC) of waste water streams such as mother liquors or wash-waters.

Other test methods for inherent biodegradability as well as screening test methods (“readily biodegradability”) are listed in Table 2.11.

The results from biodegradability testing have to be interpreted on the basis of test conditions and duration. Where screening methods (or even the BOD/TOC ratio) indicate high biodegradability, advanced testing is not necessary.

### **Economics**

*No information provided.*

### **Driving force for implementation**

Central part of process design or process review, and also part of the emission inventory.

### **References to literature and example plants**

[27, OECD, 2003], [17, Schönberger, 1991], \*001A,I\*, \*014V,I\*, \*015D,I,O,B\*, \*023A,I\*

#### 4.3.1.4 Mass balances for solvents (VOC), highly hazardous substances and heavy metals

##### Description

Mass balances are one basis for understanding the processes on a site and the development of improvement strategies. For a completed mass balance, the inputs must equal the outputs. Table 4.22 shows the elements of a mass balance on a chemical site. Not every output path is relevant in every case (e.g. heavy metals cannot be destroyed).

Input	Output	
	<i>Taking into account</i>	
Losses to air	Emissions from point sources	
	Fugitive emissions	
	Output from thermal oxidiser	
Losses to water	Loss to final effluent from WWTP	
	Influent to WWTP	
	Fugitive loss from WWTP	
	Degraded portion in WWTP	
	Loss to waste activated sludge	
	Loss to surface water	
+ opening stock	Amount consumed	Loss to product
		Intermediate storage
- closing stock		
+ amount generated	Thermal destruction on-site	Input to thermal oxidiser
		Output from thermal oxidiser
+ amount purchased		
+ amount recycled on-site	Thermal destruction off-site	
	Non-thermal destruction on-site	Other treatment
	Non-thermal destruction off-site	
	Recycle/re-use on-site	
	Recycle/re-use off-site	
	Land disposal on-site	
	Land disposal off-site	
	<i>Unknown</i>	
100 %		100 %

Table 4.22: Mass balance for a chemical site

### **Achieved environmental benefits**

Mass balances are essential for understanding on-site processes and the development of improvement strategies.

### **Cross-media effects**

*None believed likely.*

### **Operational data**

*No information provided.*

### **Applicability**

Generally applicable.

A tool for the mass balance of solvents is the solvent management plan according to Annex III of the VOC Directive 1999/13/EC [99, D2 comments, 2005].

### **Economics**

Additional measurements required (hence costs) and, therefore, additional staff are needed.

### **Driving force for implementation**

Conditions on permit, report requirements, and as mass balances can be used as a basis for the development of improvement strategies.

### **References to literature and example plants**

\*006A,I\*, \*017A,I\*, \*018A,I\*, \*019A,I\*, \*020A,I\*, \*007I\*, \*024A,I\*

### 4.3.1.5 TOC balance for waste water streams

#### Description

The TOC mass balance for waste water streams is the basis for understanding the processes on site and the development of improvement strategies. Figure 4.24 shows an example from \*015D,I,O,B\* for the year 2000. The mass balance is based on a process waste stream analysis (see also Section 4.3.1.1).

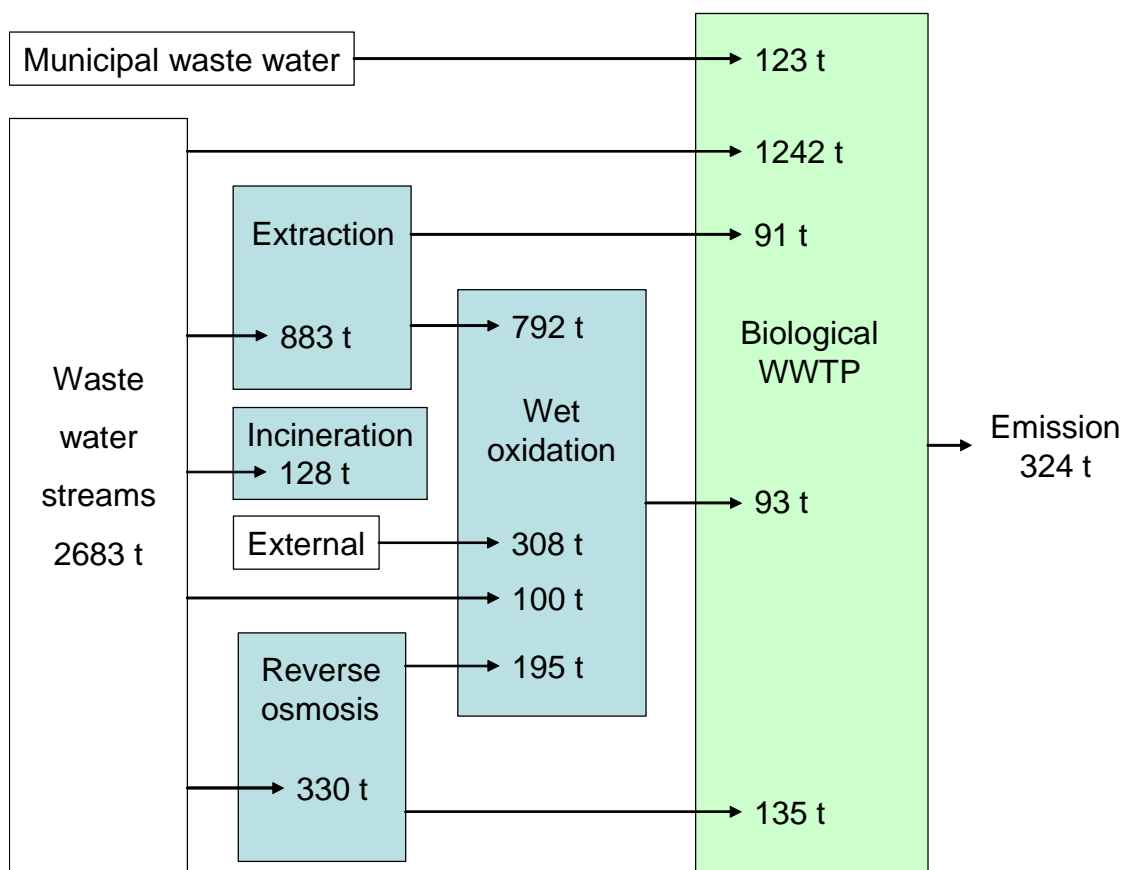

Figure 4.24: Example for a TOC balance for waste water streams

#### Achieved environmental benefits

Mass balances are essential for understanding on-site processes and the development of improvement strategies.

#### Cross-media effects

*None believed likely.*

#### Operational data

*No information provided.*

#### Applicability

Generally applicable.

### **Economics**

Additional measurements required (and hence costs) and, therefore, additional staff are needed.

### **Driving force for implementation**

Conditions on permit, report requirements, and as mass balances can be used as a basis for the development of improvement strategies.

### **References to literature and example plants**

\*015D,I,O,B\*



### 4.3.1.6 AOX balance for waste water streams

#### Description

The AOX mass balance for waste water streams is the basis for tracking halogenated compounds on the production site and the establishment of priorities for further improvement. Figure 4.25 shows an example from \*009A,B,D\* for the year 2003. The mass balance is based on a process waste stream analysis (see also Section 4.3.1.1).

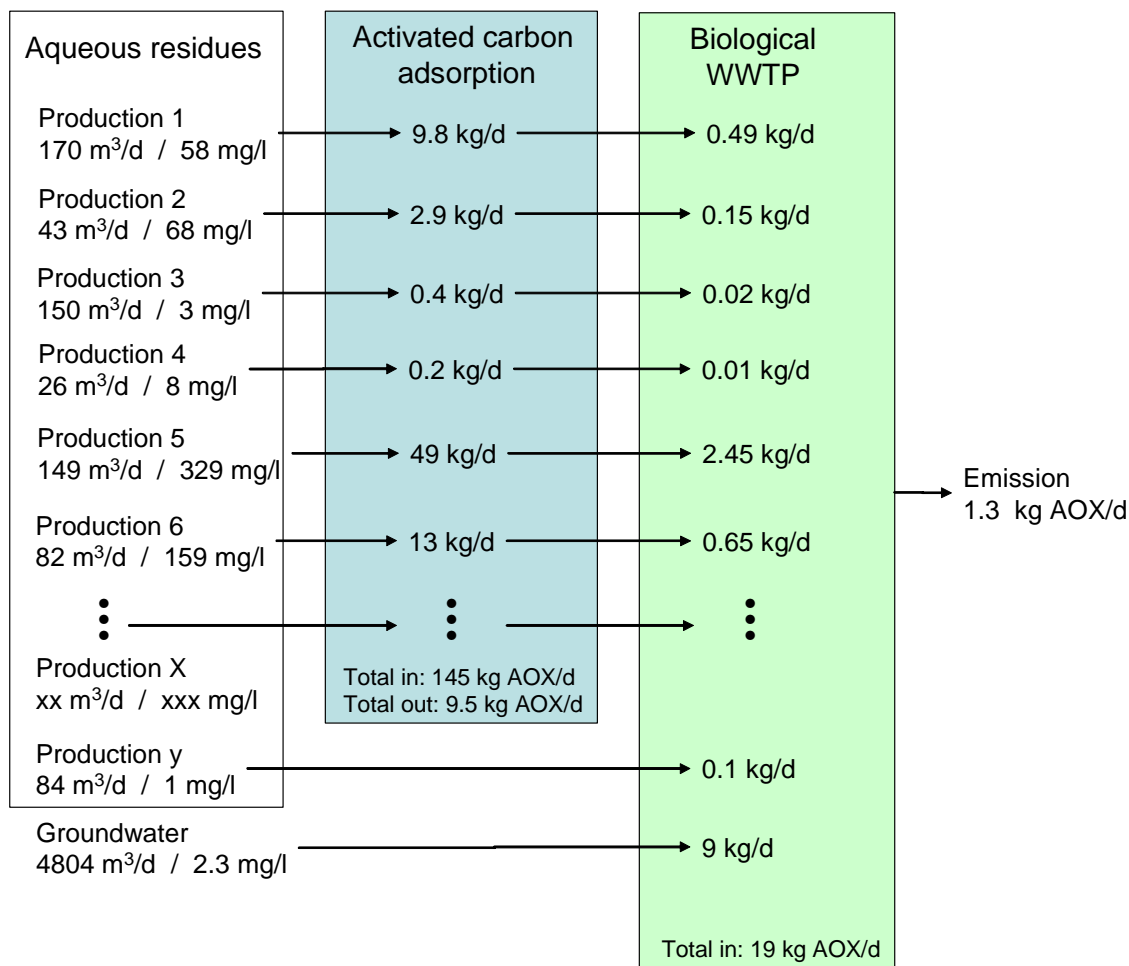

Figure 4.25: Example of an AOX balance for waste water streams

#### Achieved environmental benefits

Mass balances are essential for understanding on-site processes and the development of improvement strategies.

#### Cross-media effects

*None believed likely.*

#### Operational data

*No information provided.*

### **Applicability**

Generally applicable.

### **Economics**

Additional measurements required (hence costs) and, therefore, additional staff are needed.

### **Driving force for implementation**

Conditions on permit, report requirements, and as mass balances can be used as a basis for the development of improvement strategies.

### **References to literature and example plants**

\*009A,B,D\*

### 4.3.1.7 Monitoring of exhaust gas volume flows from processes

#### Description

The reduction of exhaust gas volume flows at source leads to a desirable intensified use of recovery and abatement systems. Regular monitoring of exhaust gas volume flows from processes, therefore provides the operator with valuable information, such as:

- situations with peak flows can represent candidates with a high potential for optimisation
- identification of volume flows arising from leaks
- obtained volume flow profiles which enable an optimised planning of production campaigns and batches.

The required flow-meters can be equipped with bypasses in order to enable maintenance or to minimise the rate of wear.

#### Achieved environmental benefits

- provides important information for optimisation and operation of a plant
- enables intensified use of recovery and abatement systems through optimised planning.

#### Cross-media effects

*None believed likely.*

#### Operational data

*No information provided.*

#### Applicability

Generally applicable.

#### Economics

Low costs for implementation. Positive effect on costs for recovery or abatement.

#### Driving force for implementation

Reduction of exhaust gas volume flows. Costs for recovery and abatement.

#### References to literature and example plants

[54, Verfahrens u. Umwelttechnik Kirchner, 2004] \*059B,I\*

### 4.3.1.8 Monitoring of waste gas emissions

#### Description

The batch mode production on an OFC site can cause significant variations of the emission levels. This effect depends on the actual situation, such as:

- less variation if the exhaust gas from many processes/operations is connected to one main recovery/abatement system
- more variation if only single production lines are connected to individual recovery/abatement systems
- more variations if dominant peak volume flows occur and are not buffered in the gas collection system or cut by the connected recovery/abatement systems.

Where variations can be expected, monitoring should reflect this and, therefore, should provide emission profiles rather than single sample points.

Figure 4.26 shows an example from \*056X\*. In this example, two batch mode production lines share a recovery/abatement system. The diagram is based on 30 minute average values and besides the “line”, the monitoring report also provides maximum, minimum and average values. Additionally, the obtained profile can be compared to the causing operations/processes carried out in the same time frame.

Where substances with ecotoxicological potential are involved, emissions of such substances are additionally monitored individually. An example is given in Table 4.23.

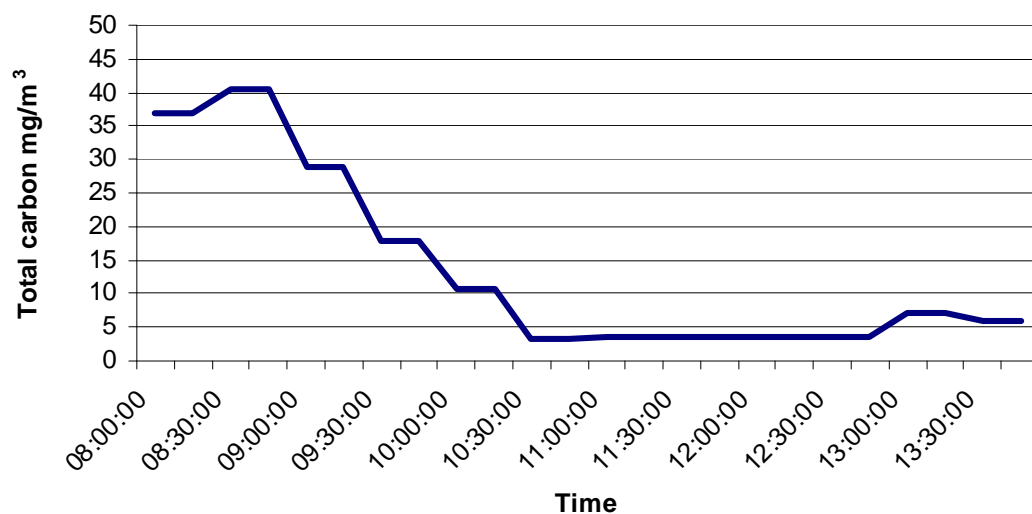

Figure 4.26: Total organic C profile from two production lines sharing one abatement system

Substance	08:00 h – 14:00 h											
	Total organic C	37.0	40.4	28.8	18.0	10.8	3.4	3.6	3.6	3.6	3.5	7.0
Propylene oxide	-	-	<1.1	-	<1.1	-	<1.1	-	<1.1	<1.1	<1.1	-
Epichlorohydrin	-	-	<1.1	-	<1.1	-	<1.1	-	<1.1	<1.1	<1.1	-
Benzyl chloride	-	-	<1.1	-	<1.1	-	<1.1	-	<1.1	<1.1	<1.1	-
Formaldehyde	-	<0.03	0.14	<0.03	0.07	0.07	0.18	-	-	-	-	-
HCl	<0.7	1.35	<0.7	<0.7	<0.7	<0.7	-	-	-	-	-	-
NH <sub>3</sub>	-	-	-	-	-	-	0.64	0.61	0.25	0.14	0.10	0.07

Table 4.23: Monitoring profile for individual substances (mg/m<sup>3</sup>, 30 min values)

**Achieved environmental benefits**

Enables monitoring data with indepth information.

**Cross-media effects**

*None believed likely.*

**Operational data**

*No information provided.*

**Applicability**

Generally applicable.

For plants with numerous different processes fed to an exhaust abatement, the installation of a continuous monitoring system of the VOC emission, e.g. using a flame ionisation detector (FID) can be necessary for emission controlling. For information regarding “Stationary source emission quality assurance of automatic measuring systems” see EN 14181 [99, D2 comments, 2005].

**Economics**

Added costs for longer sampling times and analysis/evaluation. Higher cost in the case of continuous monitoring.

**Driving force for implementation**

Need to reflect the real emission situation.

**References to literature and example plants**

\*056X\*

### 4.3.2 Waste streams from unit processes

#### 4.3.2.1 Waste streams from N-acylation

##### Description

The main waste streams from N-acylations are:

- exhaust gases containing low molecular compounds such as acetic acids or ethanol and possibly solvents such as xylene
- mother liquors containing high loads of low molecular compounds and, depending on the particular process, lost product and by-products, aluminium, and also AOX loads if acetic chloride is used.

VOCs/solvents can be recovered from the exhaust gas by condensation and can be re-used internally or commercially, where necessary, after purification.

If the process is carried out in aqueous solution, the mother liquors are highly loaded with ethanol or acetic acid. This is also the case, if the reaction mass after the reaction is extracted with an organic solvent. If not contaminated with low degradable product losses or by-products, these waste water streams are expected to be readily biodegradable but may challenge the capacity of an existing WWTP.

If the conditions allow this, and similar yields can be achieved, acetylation with acetic anhydride can also be carried out in a dry process (see Section 4.1.4.2).

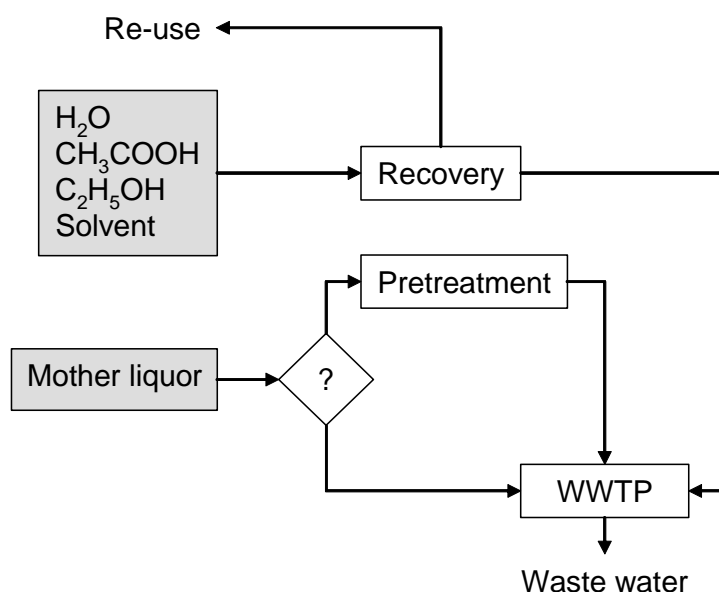

Figure 4.27: Recovery/abatement techniques for waste streams from N-acylations

Waste stream	Properties	
Acetylation of 2-naphthylamine-8-sulphonic acid in aqueous solution [9, Christ, 1999]		
Mother liquors	For each 1000 kg product: <ul style="list-style-type: none"> <li>• 1200 kg ammonium sulphate</li> <li>• 1000 kg COD</li> <li>• 2000 kg sewage sludge after WWTP</li> </ul>	biological WWTP

Table 4.24: Example for the treatment of waste streams from N-acetylation

**Achieved environmental benefits**

Lower emission levels and improved efficiency in the case of recovery.

**Cross-media effects**

Effects of the recovery/abatement techniques.

**Operational data**

*No information provided.*

**Applicability**

Generally applicable.

**Economics**

*No information provided.*

**Driving force for implementation**

Lower emission levels, and improved efficiency in the case of recovery.

**References to literature and example plants**

[9, Christ, 1999]

## 4.3.2.2 Waste streams from alkylations with alkyl halides

## Description

The expected waste streams from alkylation with alkyl halides are:

- exhaust gases, containing VOCs from organic feed and side reactions
- waste water streams, containing high organic loadings from lost organic feed and side reactions.

The formation of lower molecular compounds leads to organic loadings both in gaseous and waste water streams. Table 4.25 gives some examples for waste streams from alkylations with alkyl halides and Figure 4.28 shows the treatment of waste streams from alkylations with alkyl halides.

**Exhaust gases** are treated by thermal oxidation or, in the cases of high water solubility, by absorption in water scrubbers. The organic load from absorption is further treated in a biological WWTP.

The expected high loads in waste water streams are usually readily biodegradable but may challenge the capacity of a WWTP. Alternatively lower molecular compound loadings can be shifted to the waste gas pathway by stripping the waste water stream with steam. As a consequence it may be possible to operate a thermal oxidiser autothermally.

Waste stream	Properties	Recovery/abatement
<b>Methylation with methyl chloride</b> [15, Köppke, 2000]		
Waste water stream	Volume 20 – 30 m <sup>3</sup> /h COD 20000 mg/l BOD <sub>5</sub> 14000 mg/l	Stripping/biological WWTP and thermal oxidation See also Section 4.3.5.9
Exhaust gas	2000 m <sup>3</sup> /h e.g. dimethyl ether, methyl chloride	
<b>Production of theobromine with methyl chloride and a phase transfer catalyst</b> [9, Christ, 1999]		
Mother liquor from purification 1		Recycled to process
Mother liquor from purification 1	60 kg COD per tonne product	Biological WWTP
Spent catalyst and filtration residue	50 kg waste per tonne product	Incineration
<b>Production of an API by alkylation in a non-aqueous solution</b> [67, UBA, 2004]		
Waste water stream from two stage extraction with NaOH	COD 390 g/l, 150 t/year BOD 270 g/l Degradability 96 %	Biological WWTP
Waste water stream from two stage extraction with H <sub>2</sub> SO <sub>4</sub> /water	COD 33 g/l BOD 12 g/l Degradability 96 % T <sub>N</sub> 1.2 g/l	Biological WWTP

**Table 4.25: Examples for treatment of waste streams from alkylation with alkyl halides**



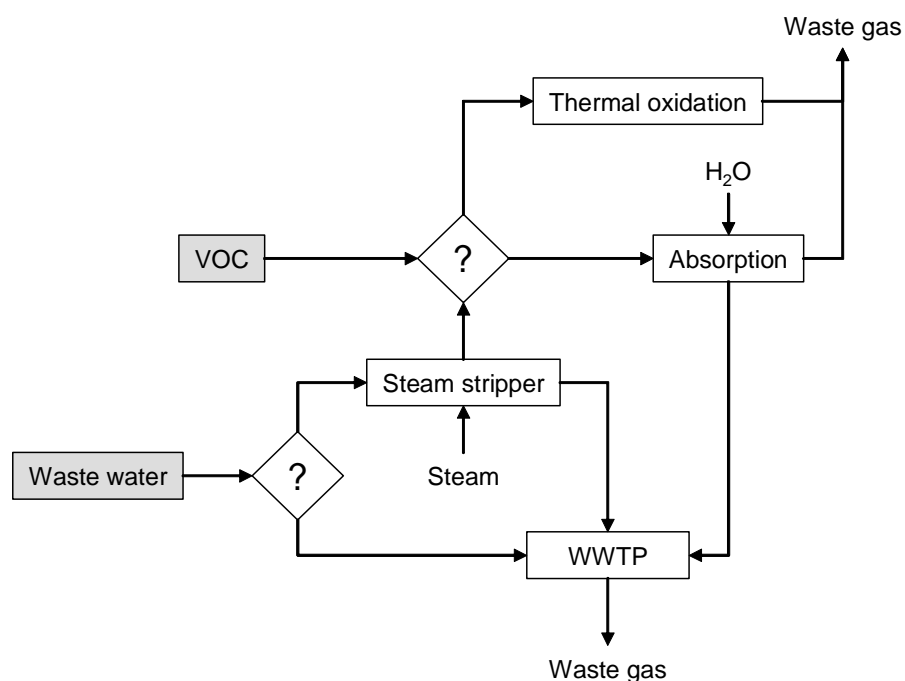

Figure 4.28: Recovery/abatement techniques for waste streams from alkylation with alkyl halides

#### Achieved environmental benefits

Lower emission levels, improved efficiency in the case of recovery.

#### Cross-media effects

Effects of the recovery/abatement techniques.

#### Operational data

*No information provided.*

#### Applicability

Generally applicable.

#### Economics

*No information provided.*

#### Driving force for implementation

Lower emission levels, improved efficiency in the case of recovery.

#### References to literature and example plants

See Table 4.25.

## 4.3.2.3 Waste streams from condensations

## Description

The main waste streams from condensations are:

- exhaust gases containing VOCs from the use of solvents or volatile reactants
- aqueous or organic mother liquors
- waste water streams from extractions and product washing containing organic loadings.

Figure 4.29 shows the treatment techniques for waste streams from condensations and shows some examples for treatment of such waste streams.

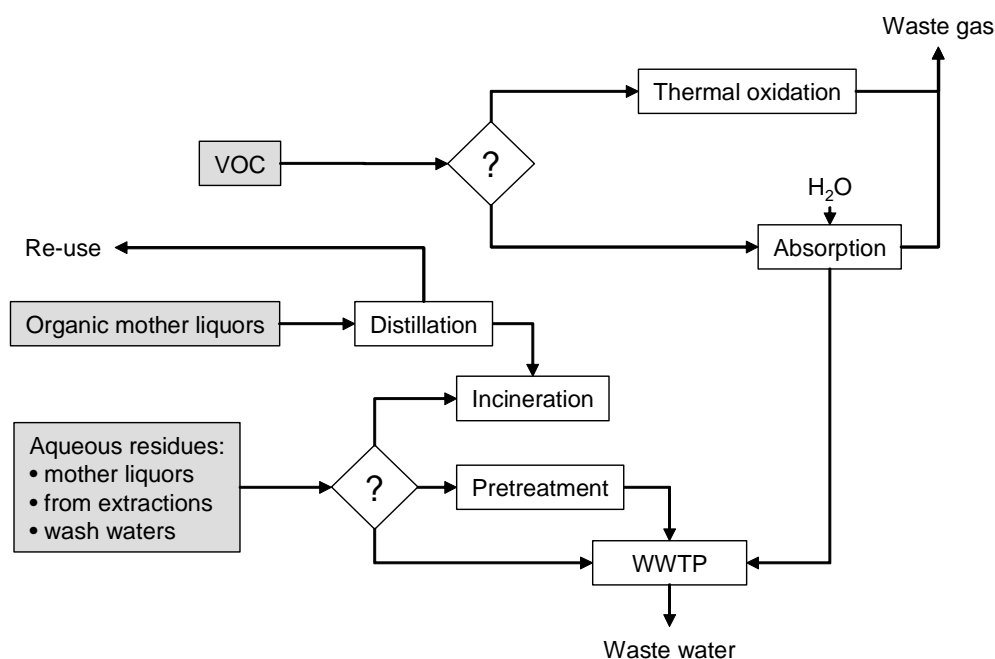

Figure 4.29: Recovery/abatement techniques for waste streams from condensations

Waste stream	Properties	Recovery/abatement
Production of an intermediate for a plant health product [62, D1 comments, 2004]		
Mother liquor after filtration	Volume 17700 m <sup>3</sup> /yr TOC 2.8 g/l, 50 kg/day, 49 t/yr Degradability 73 % AOX 300 mg/l, 5.4 t/yr	biological WWTP
Production of an API [62, D1 comments, 2004]		
Aqueous phases from extractions and product washing	Volume 10 m <sup>3</sup> /yr COD 80 g/l, 800 kg/yr BOD 64 g/l Degradability 47 % T <sub>N</sub> 43 g/l	Disposal (incineration)

Table 4.26: Examples for the treatment of waste streams from condensations

**Exhaust gases** are treated by thermal oxidation or, in the cases of high water solubility, by absorption in water scrubbers. The organic load from absorption is further treated in a biological WWTP.

**Waste water streams** are considered for pretreatment, disposal (incineration) or direct treatment in the biological WWTP, mainly depending on load and bioeliminability of the organic content.

**Organic residues** are considered for distillation and re-use on-site or off-site. Residues from distillations are disposed of (incineration).

#### **Achieved environmental benefits**

Lower emission levels, improved efficiency in the case of recovery.

#### **Cross-media effects**

Effects of the recovery/abatement techniques.

#### **Operational data**

*No information provided.*

#### **Applicability**

Generally applicable.

#### **Economics**

*No information provided.*

#### **Driving force for implementation**

Lower emission levels, improved efficiency in the case of recovery.

#### **References to literature and example plants**

[6, Ullmann, 2001, Winnacker, 1982 #16]

### 4.3.2.4 Waste streams from diazotisation and azo coupling

#### Description

The main waste streams from diazotisation and azo coupling are:

- exhaust gas containing HCl from the diazotisation stage
- mother liquor, often containing high loads of refractory COD and possibly AOX (if halogenated starting materials are used), high salt loads from salting out, and possibly heavy metals from the formation of metal complex dyes
- wash-water containing lower loads of refractory COD and possibly AOX (if halogenated starting materials are used), and possibly heavy metals from the formation of metal complex dyes
- permeate from pressure permeation, containing a low COD load, possibly a low AOX load (if halogenated starting materials are used) and a lower salt load.

Figure 4.30 shows the treatment techniques for waste streams from diazotation and azo coupling. Table 4.27 gives some example data for waste streams from diazotisation and azo coupling. Table 4.28 gives examples from azo dye manufacturing where heavy metals are involved. Table 4.29 shows detailed examples for the treatment of mother liquors.

Where loads and results from Zahn-Wellens testing are available, a refractory COD according to the result of bioeliminability testing and dilution to 2000 m<sup>3</sup> effluent was calculated to illustrate the effect on COD concentrations in the discharged waste water.

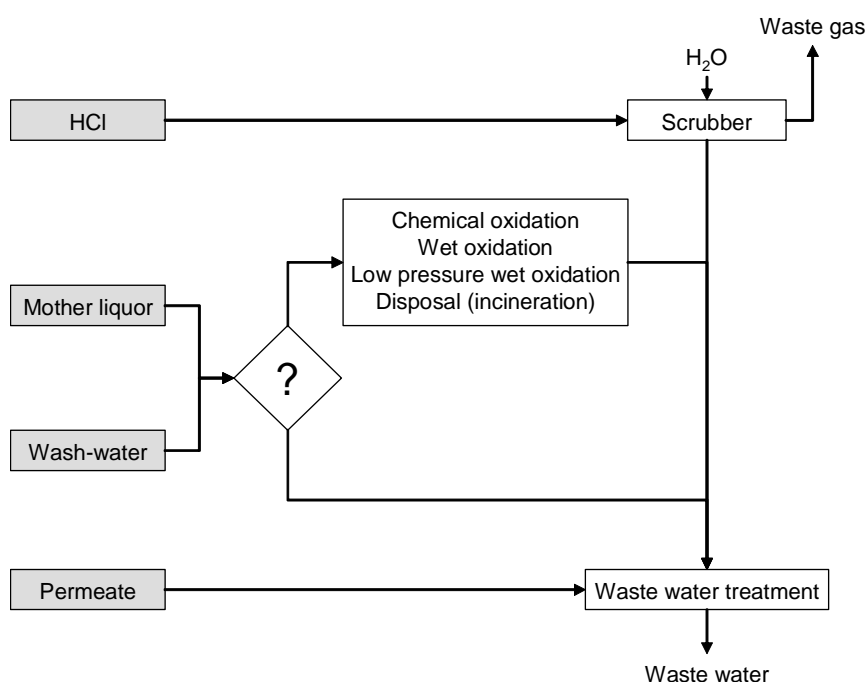

**Figure 4.30: Applied abatement techniques for waste streams from diazotation and azo coupling**

Exhaust gases are absorbed in water scrubbers.

Mother liquors and also wash-waters from the manufacture of water soluble azo dyes often contain high COD loads, often with a low bioeliminability. This is especially the case if unreacted starting material remains. Therefore, it is crucial to check if diazo or coupling components are still present in the reaction mixture.

In cases where halogenated starting materials are used, a high AOX load can be expected. Mother liquors and wash-waters and with low bioeliminability are pretreated upstream to the biological treatment of the total effluent. Methods of choice are e.g. chemical oxidation, wet oxidation, low pressure wet oxidation or disposal (incineration). Permeates from pressure permeation usually show lower loads and are treated together with the total effluent.

### Achieved environmental benefits

Lower emission levels, and improved efficiency in the case of recovery.

### Cross-media effects

Effects of the recovery/abatement techniques.

Waste stream	Properties			Reference
<b>Manufacture of water soluble azo dyes</b>				
Mother liquor, wash-water	Manufacture of 1 tonne dye			
	Waste water stream:	7 tonnes		[9, Christ, 1999]
	Salt load:	1.5 tonnes		
COD load:	50 kg			
<b>Mother liquors</b>				
	TOC	BOD/ TOC	DOC* elimination after 13 days (Zahn Wellens test)	
	mg/l			
Diazo dye		0.2	16 %	[17, Schönberger, 1991]
Azo disperse dye		0.4	35 %	
Azo disperse dye	1170	0.9	41 %	
Azo disperse dye	1330	0.5	48 %	
Azo disperse dye	1970	0.8	49 %	
Azo disperse dye	953	0.4	51 %	
Azo disperse dye	1170	0.6	54 %	
Nitrated monoazo dye	10200	0.3	72 %	
Nitrated monoazo dye	8490	0.2	72 %	
Nitrated monoazo dye		1.5	75 %	
Nitrated monoazo dye	1140	1.2	75 %	
Nitrated monoazo dye	1560	1.7	76 %	
Azo dye for wool		0.5	95 %	
* Dissolved organic carbon				

**Table 4.27: Example data for waste streams from diazotisation and azo coupling**

			Diluted to 2000 m <sup>3</sup> ( <sup>i</sup> see note)
<b>Formation of a 1:2 co-ordinated Cr azo dye mixture with Cr acetate *015D,I,O,B*</b>			
Mother liquor 15 m <sup>3</sup> /batch	TOC	47000 mg/l	
	COD	76000 mg/l	
	BOD/TOC	0.12	
	Degradability (Zahn-Wellens)	100 %	
	NH <sub>4</sub> -N	56000 mg/l	
	Chromium	32 mg/l	0.24 mg/l
Wash-water 12 m <sup>3</sup> /batch	TOC	40000 mg/l	
	COD	9000 mg/l	
	Degradability (Zahn-Wellens)	100 %	
	NH <sub>4</sub> -N	4000 mg/l	
	Chromium	3 mg/l	0.018 mg/l
<b>Formation of a 1:2 co-ordinated Cr azo dye *015D,I,O,B*</b>			
Mother liquor 20 m <sup>3</sup> /batch	TOC	5000 mg/l	
	AOX	410 mg/l	
	Degradability (Zahn-Wellens)	90 %	
	Chromium	47 mg/l	0.47 mg/l
<b>Formation of a Cr azo dye with Cr acetate *015D,I,O,B*</b>			
Mother liquor 20 m <sup>3</sup> /batch	TOC	40000 mg/l	
	Degradability	100 %	
	Chromium	130 mg/l	1.30 mg/l
	NH <sub>4</sub> -N	50000 mg/l	
Wash-water 60 m <sup>3</sup> /batch	TOC	2000 mg/l	
	Degradability	95 %	
	Chromium	8 mg/l	0.24 mg/l
	NH <sub>4</sub> -N	1400 mg/l	
<b>Formation of an Cr azo dye in one-pot synthesis *015D,I,O,B*</b>			
Mother liquor	Chromium	165 mg/l	
Wash-water 1	Chromium	200 mg/l	
Wash-water 2	Chromium	50 mg/l	
<sup>i</sup> Calculated concentration after dilution to a total effluent of 2000 m <sup>3</sup> without pretreatment			

Table 4.28: Examples for waste streams from azo dye manufacture involving heavy metals

[51, UBA, 2004]				
		Destination	COD after degradation and dilution to 2000 m <sup>3</sup> (* see note)	
Example 1	<b>Mother liquor</b>		Biological treatment	35 mg/l
	Volume per batch	10 m <sup>3</sup>		
	COD	70 g/l		
	BOD/TOC	0.01		
	Degradability	90 %		
	SO <sub>4</sub>	5 g/l		
	<b>Wash-water</b>		Biological treatment	45 mg/l
	Volume per batch	15 m <sup>3</sup>		
COD	30 g/l			
Degradability	80 %			
Example 2	<b>Mother liquor</b>		Pretreatment by high pressure wet oxidation	63 mg/l
	Volume per batch	18 m <sup>3</sup>		
	COD	20 g/l		
	Degradability	65 %		
	<b>Wash-water</b>		Biological treatment	21 mg/l
	Volume per batch	16 m <sup>3</sup>		
Degradability	80 %			
Example 3	<b>Mother liquor</b>		Pretreatment by high pressure wet oxidation or incineration	163 mg/l
	Volume per batch	10 m <sup>3</sup>		
	Degradability	35 %		
Example 4	<b>Mother liquor</b>		Biological treatment	106 mg/l
	Volume per batch	9.5 m <sup>3</sup>		
	COD	32 g/l		
	Degradability	30 %		
Example 5	<b>Mother liquor</b>		Biological treatment	6 mg/l
	Volume per batch	16 m <sup>3</sup>		
	COD	16 g/l		
	Degradability	95 %		
	SO <sub>4</sub>	2000 kg		
Example 6	<b>Mother liquor</b>		Pretreatment by high pressure wet oxidation	92.5 mg/l
	Volume per batch	19 m <sup>3</sup>		
	COD	370 kg		
	Degradability	50 %		
	<b>Wash-water</b>		Biological treatment	30 mg/l
	COD	110 kg		
	Degradability	45 %		
	BOD <sub>5</sub>	20 kg		

\* Refractory COD according to the result of bioeliminability testing and dilution to 2000 m<sup>3</sup>

**Table 4.29: Examples for mother liquors and wash-waters from diazotisation/azo coupling**

### Operational data

No information provided.

### **Applicability**

Generally applicable.

Activated carbon adsorption is another alternative for pretreatment prior to biological waste water treatment [99, D2 comments, 2005].

### **Economics**

*No information provided.*

### **Driving force for implementation**

Lower emission levels, and improved efficiency in the case of recovery.

### **References to literature and example plants**

[9, Christ, 1999, 17, Schönberger, 1991, 51, UBA, 2004],



### 4.3.2.5 Waste streams from halogenation

#### Description

The main waste streams from halogenation are:

- exhaust gas containing halogens, the related hydrohalogenic acid and VOC/HHC. The loads depend on reactants and reaction conditions
- aqueous mother liquor containing high loads of COD/AOX arising from the by-products and lost product
- wash-waters containing lower loads of COD/AOX due to by products and lost product
- organic mother liquor containing solvent, by-products and lost product
- distillation residues and unwanted by-products containing a mixture of halogenated compounds.

Figure 4.31 shows the treatment of the waste streams from halogenation.

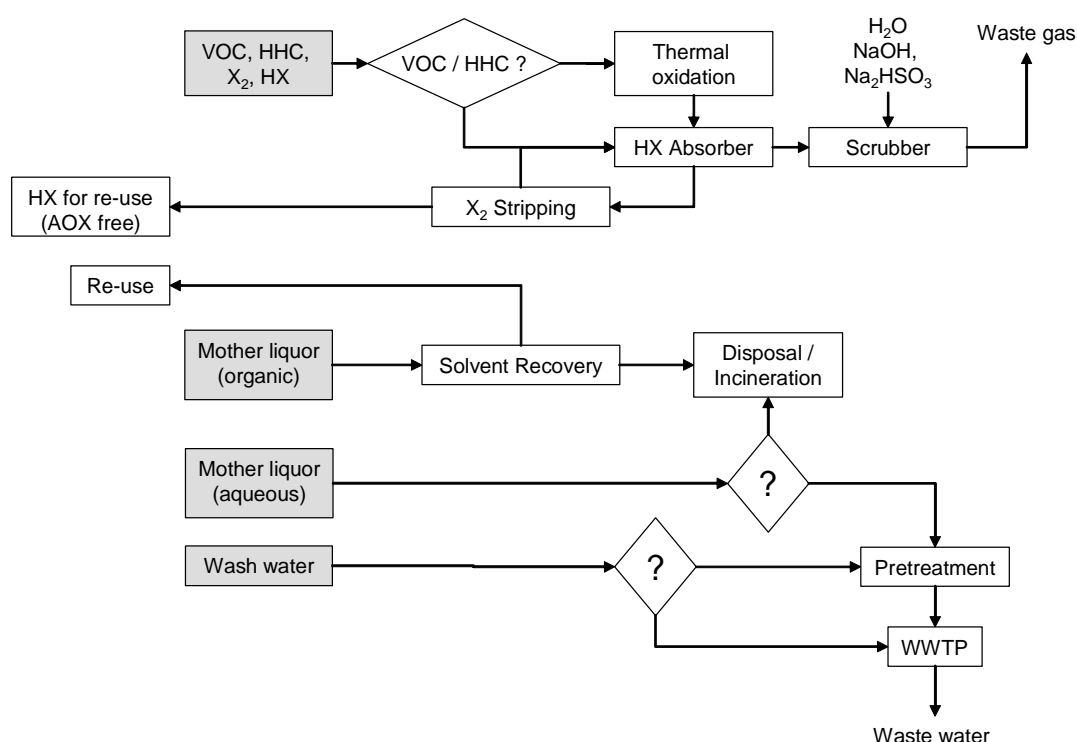

Figure 4.31: Recovery/abatement techniques for waste streams from halogenations

Table 4.30 gives some examples for waste streams from halogenations. The **exhaust gases** contain HX, X<sub>2</sub>, N<sub>2</sub> and VOC/HHC. A high percentage of the halogen (80 % in the case of chlorine) can be removed in a scrubbing tower (e.g. a bubble column) containing an easily halogenatable compound, preferably a raw material used in the halogenation process, and a catalyst (see also Section 4.3.5.5). The waste gas is then burned at temperatures of about 1100 °C and dwell times of 1 – 2 seconds in order to remove HHCs. If the waste gas does not contain HHCs, oxidisers are operated at lower temperatures in order to reduce the formation of NO<sub>x</sub> (about 800 °C with a dwell time of 0.75 second). The hydrogen halide is then absorbed in water in a scrubber. After stripping, an AOX free hydrohalogenic acid of marketable quality can be obtained (see also Section 4.3.5.2). Afterwards, the gas stream is treated in another scrubber to remove the remaining halogen. Alternatively, organic constituents of the reaction gas are washed out with a high boiling solvent in another scrubbing tower. If the exhaust gas does not contain the required portions of organic compounds, the treatment is restricted to the scrubbing stages.

Waste stream	Properties	Recover/abatement
<b>Side chain chlorination</b> [15, Köppke, 2000]		
HCl, Cl <sub>2</sub> , Chlorotoluene (and N <sub>2</sub> )	Flowrate: 500 m <sup>3</sup> /h HCl 720 kg/h Cl <sub>2</sub> 31 kg/h Chlorotoluene 14 kg/h N <sub>2</sub> 45 kg/h	Thermal oxidation HCl recovery Cl <sub>2</sub> destruction
Distillation residue and unwanted by-products (From production of 100 t p-chlorobenzylchloride, 454.7 t p-chlorobenzaldehyde and 141 t p-chlorobenzoyl chloride)	40.9 tonnes, containing p-chlorobenzalchloride and p-chlorobenzotrichloride, polymers calorific value: 25000 kJ/kg	Incineration
<b>Bromination of a carbonic acid with co-production of CH<sub>3</sub>Br</b> *007I*		
HBr, Br <sub>2</sub> , N <sub>2</sub> , CH <sub>3</sub> OH, CH <sub>3</sub> Br Discharge per batch to HBr absorber	Flowrate (max.) 250 m <sup>3</sup> /h HBr 11350 kg Br <sub>2</sub> 750 kg N <sub>2</sub> 1000 kg CH <sub>3</sub> OH 350 kg CH <sub>3</sub> Br 100 kg	Recovery of HBr Scrubbers (see also Section 4.3.5.4)
<b>Manufacture of bromamine acid</b> [16, Winnacker and Kuechler, 1982]		
Mother liquor	Per batch, starting with 180 kg 1-aminoanthraquinone-2-sulphonic acid Loss of 26 kg starting material	
<b>Manufacture of an intermediate by chlorination (and partial oxidation)</b> [67, UBA, 2004]		
Mother liquor from crystallisation/filtration		Disposal/incineration
Waste water from scrubbing and product washing	Volume 400 m <sup>3</sup> /yr TOC 105 g/l (40 kg/d, 41 t/yr) AOX 16 g/l (6 kg/d) Degradability 94 %	Biological WWTP
<b>Manufacture of 4-chloro-3-methylphenol by chlorination</b> [26, GDCh, 2003]		
Exhaust gases		Thermal oxidation/scrubbers
<b>Manufacture of Trichloroacetic acid/Na trichloroacetate</b> [26, GDCh, 2003]		
Exhaust gases		Thermal oxidation/scrubbers
<b>Manufacture of p-dichlorobenzene</b> [26, GDCh, 2003]		
Exhaust gases		Thermal oxidation/scrubbers
<b>Manufacture of benzyl chloride by side chain chlorination</b> [26, GDCh, 2003]		
Exhaust gases		Thermal oxidation/scrubbers
Waste water from scrubbing		Biological WWTP

Table 4.30: Examples for treatment of waste streams from halogenation

**Distillation residues, unwanted by-products.** Aromatics containing more than 1 % organically bound chlorine are burned in furnaces that provide sufficient reaction temperatures and dwell times in order to reduce emissions of polychlorodibenzodioxins/-furans. In an excess of oxygen, the halogenated compounds are converted into hydrogen halide, carbon dioxide and water. The hydrogen halide is removed from the flue-gas by water scrubbers. For more information see the BREF on Waste Incineration [103, European Commission, 2005].

**Aqueous mother liquors** contain high loads of COD/AOX with refractory or toxic properties and special pretreatment is carried out upstream to the treatment of the total effluent. Alternatively, such waste water streams are considered for disposal (incineration).

**Wash-waters** also have to be considered for pretreatment, depending on refractory loads or toxic properties, or are treated in the biological WWTP.

#### **Achieved environmental benefits**

Lower emission levels, improved efficiency in the case of recovery.

#### **Cross-media effects**

Effects of the recovery/abatement techniques.

#### **Operational data**

*No information provided.*

#### **Applicability**

Generally applicable.

#### **Economics, Driving force for implementation**

*No information provided.*

#### **References to literature and example plants**

See Table 4.30.

## 4.3.2.6 Waste streams from nitrations

## Description

The main waste streams from nitration processes are:

- exhaust gas, containing SO<sub>x</sub> and NO<sub>x</sub> from oxidative side reactions, and VOCs. The loads depend on the temperature and the strength of the mixed acid
- mother liquor from the phase separation or filtration, containing high loads of organic by-products (and lost product) and diluted mixed acid
- wash-water from product washing containing possible unwanted isomers and organic by-products, especially phenolic compounds in the case of aromatic nitration
- exhaust gas from recrystallisation of the product with organic solvent, containing VOCs
- distillation residues and possibly unwanted isomers
- second filtrate from the recrystallisation, an aqueous or organic phase containing lower concentrations of organic by-products, and unwanted isomers.

Table 4.31 gives some example data for the waste streams from nitration and Figure 4.32 shows the applied abatement techniques.

Waste stream from	Properties	Destination
Mononitration of toluene *087I*	Spent acid	Regeneration
	Alkali wash-water, pH 10 up to 2 m <sup>3</sup> /h, COD 20000 mg/l nitro toluene isomers 4750 mg/l nitro cresoles 11200 mg/l non degradable T <sub>N</sub> : 5400 mg/l	Wet oxidation with air
Manufacture of TNT *062E*	Spent acid	Regeneration
	“Red water” from selliting (see also Section 4.2.22) unsymmetric nitrotoluenes (6 – 7 % of the TNTs) non degradable	Incineration
Manufacture of nitroglycol *45E*	NO <sub>x</sub> , SO <sub>x</sub>	Scrubbing
[15, Köppke, 2000]	NO <sub>x</sub> , SO <sub>x</sub> , VOC	
	The loads depend on the temperature and the strength of the mixed acid NO <sub>x</sub> up to 400 g/m <sup>3</sup>	
Manufacture of an intermediate for an API (346 kg product) *025A,I*	Mother liquor: 2810 litre 1. wash-water: 4500 litre 2. wash-water/methanol: 2300 litre	Incineration
Manufacture nitrocellulose *044E*	NO <sub>x</sub> 10.2 g/m <sup>3</sup>	Recovered by scrubbing, recycling of nitric acid or market to fertiliser industry
Manufacture of H acid (sequence of sulphonation, nitration, alkaline fusion) [9, Christ, 1999]	Exhaust gases	Thermal oxidation
	Mother liquor	High pressure wet oxidation

Table 4.31: Example data for the waste streams from nitration

The mother liquors are diluted sulphuric acids and can be regenerated (for example, spend acid from the acid washing after nitration of nitrocellulose contains 40 %  $\text{H}_2\text{SO}_4$ , 25 % nitric acid and 35 %  $\text{H}_2\text{O}$ ). Whereas most nitroaromatics have low solubilities, derivatives with one or more sulphonic acid groups are moderately soluble in water, and nitrophenols can be washed out with diluted  $\text{NaOH}$ . Because of the possible toxicity and/or low biodegradability of nitroaromatics or nitrophenols, a special pretreatment is necessary for the wash-water, such as adsorption on activated carbon or ion-exchanger resins. Alternatively, oxidative pretreatment is applied. Wash-waters and filtrates from the recrystallisation can sometimes be re-used in the process instead of fresh water.

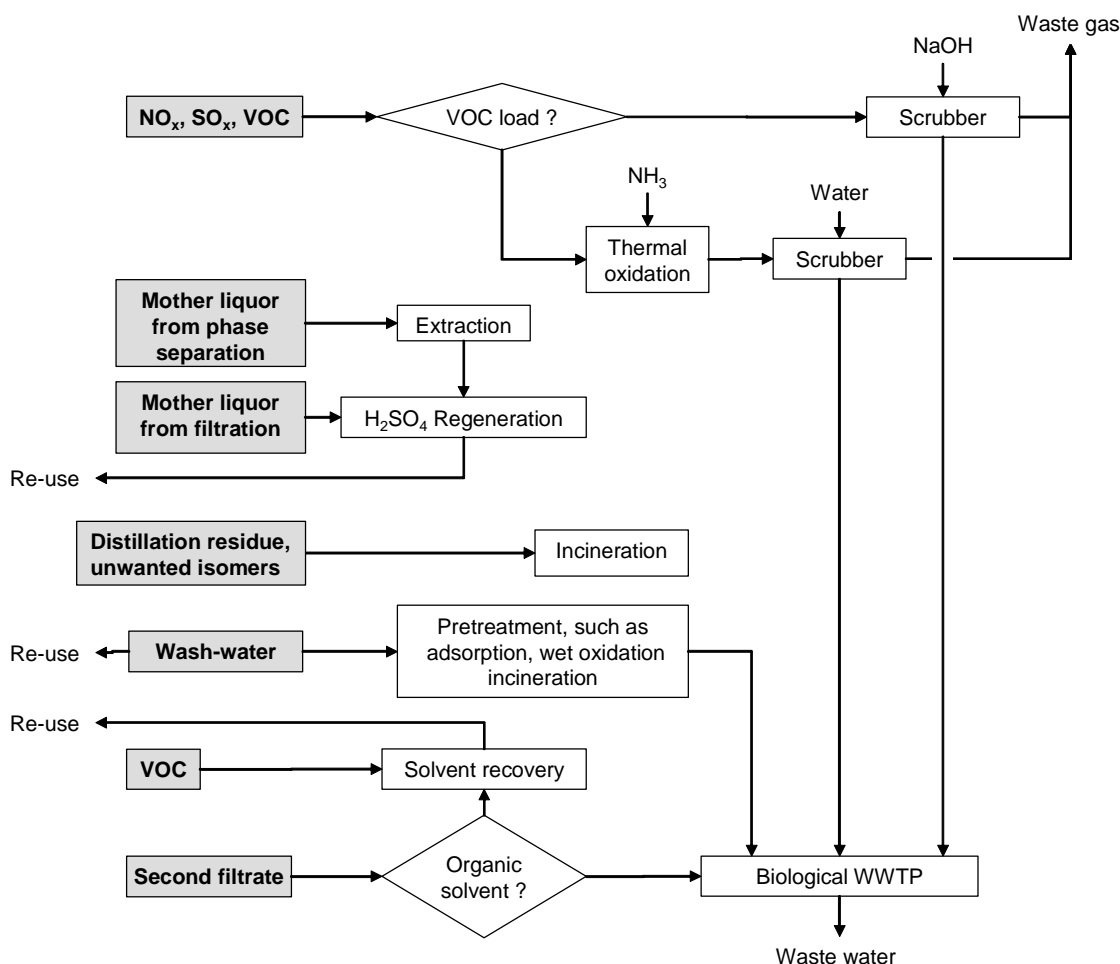

Figure 4.32: Applied abatement techniques for the waste streams from nitration

#### Achieved environmental benefits

Lower emission levels, improved efficiency in the case of recovery.

#### Cross-media effects

Effects of the recovery/abatement techniques.

#### Operational data

*No information provided.*

### **Applicability**

Generally applicable.

### **Economics**

*No information provided.*

### **Driving force for implementation**

Lower emission levels, and improved efficiency in the case of recovery.

### **References to literature and example plants**

[9, Christ, 1999, 15, Köppke, 2000], \*025A,I\*, \*087I\*

### 4.3.2.7 Waste streams from the reduction of aromatic nitro compounds

#### Description

The main waste streams from nitration processes are:

- exhaust gas from the reduction stage containing VOCs and possibly traces of sulphur compounds
- solid residues from iron reduction containing iron oxides and organic compounds
- catalysts
- aqueous mother liquors obtained after steam distillation, extraction, phase separation or salting out and filtering containing high COD and/or AOX loads, depending on the solubility and the degree of halogenation of the input materials, possibly sulphur compounds and possibly residual catalysts (e.g. Nickel)
- organic mother liquors.

Table 4.32 gives some examples for properties and treatment of waste streams from the reduction of aromatic nitro compounds, and Figure 4.33 shows the treatment techniques.

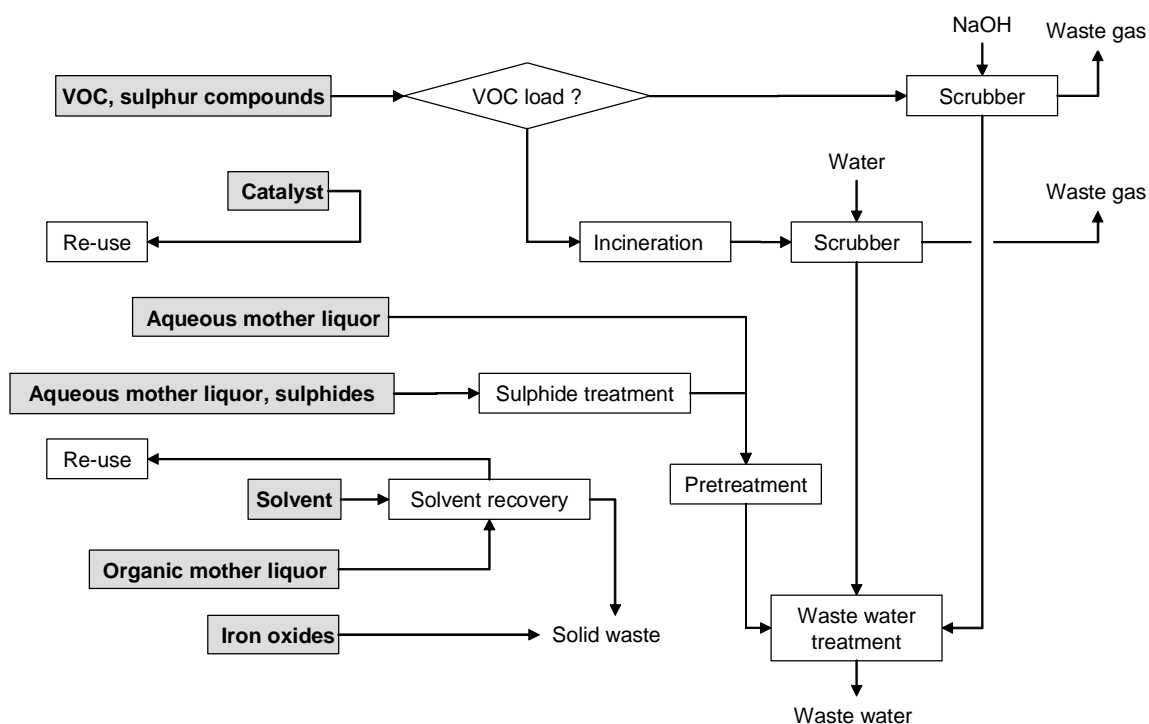

Figure 4.33: Treatment of waste streams from the reduction of nitroaromatics

The exhaust gases are treated by incineration in combination with scrubbing of the flue-gas or by scrubbing only, depending on the VOC load.

Iron reduction leads to large amounts of residual iron oxides contaminated with organic compounds which have to be disposed of. Despite the additional costs of disposal, iron reduction is still in use for low volume products (<100 tonnes per year), because of the high investment costs for the catalytic process equipment.

Waste stream	Properties	Treatment
<b>Catalytic reduction of p-nitro-toluene with H<sub>2</sub></b> [16, Winnacker and Kuechler, 1982]		
(Manufacture of 1000 kg toluidine)		
Solid residues	2 kg	
Waste water stream	0.4 m <sup>3</sup> saturated with base	
<b>Catalytic reduction of an intermediate *018A,I*</b>		
Mother liquor	1.84 kg nickel/batch, after filtration	Precipitation/filtration, biological WWTP
<b>Reduction of p-nitro-toluene with iron</b> [16, Winnacker and Kuechler, 1982]		
(Manufacture of 1000 kg toluidine)		
Solid residues	2200 kg (2170 kg iron oxide, 30 kg organics)	
Waste water stream	20 m <sup>3</sup> saturated with base	
<b>Manufacture of 4-aminodiphenylamine by catalytic reduction</b> [26, GDCh, 2003]		
Waste water stream		Biological WWTP
Exhaust gas		Thermal oxidation
<b>Manufacture of 2,4-dichloroaniline by catalytic reduction</b> [26, GDCh, 2003]		
Waste water stream		Activated carbon absorption, stripping, biological WWTP
Exhaust gas		Thermal oxidation/scrubber
<b>Manufacture of 2,5-dichloroaniline by catalytic reduction</b> [26, GDCh, 2003]		
Waste water stream		Activated carbon absorption, stripping, biological WWTP
Exhaust gas		Thermal oxidation/scrubber
<b>Manufacture of 3,4-dichloroaniline by catalytic reduction</b> [26, GDCh, 2003]		
Waste water stream		Activated carbon absorption, stripping, biological WWTP
Exhaust gas		Thermal oxidation/scrubber
<b>Manufacture of p-chloroaniline by catalytic reduction</b> [26, GDCh, 2003]		
Waste gas		Thermal oxidation/scrubber
<b>Manufacture of 2,4,5-trichloroaniline by catalytic reduction</b> [26, GDCh, 2003]		
Waste water stream		Activated carbon absorption, stripping, biological WWTP
Exhaust gas		Scrubber (closed system)

**Table 4.32: Treatment of waste streams from reduction of nitroaromatics**

The catalyst is recovered and re-used.

Depending on the solubility of the aromatic amine produced, the aqueous mother liquors contain high COD and – if the starting compound is halogenated – also high AOX loads. High solubility is expected especially in the presence of additional hydrophilic substituents (e.g. such as -Cl, -NO<sub>2</sub>, -SO<sub>3</sub>H). The biodegradability also depends on the particular starting material/product. In the cases of low biodegradability or toxic properties, a special pretreatment is carried out upstream of the biological treatment of the total effluent. Mother liquors from the alkali sulphide reduction require a special pretreatment in order to remove sulphur compounds, usually involving precipitation as metal sulphides.



**Achieved environmental benefits**

Lower emission levels, and improved efficiency in the case of recovery.

**Cross-media effects**

Effects of the recovery/abatement techniques.

**Operational data**

*No information provided.*

**Applicability**

Generally applicable.

**Economics**

*No information provided.*

**Driving force for implementation**

Lower emission levels, and improved efficiency in the case of recovery.

**References to literature and example plants**

[16, Winnacker and Kuechler, 1982, 26, GDCh, 2003].

## 4.3.2.8 Waste streams from sulphonation

## Description

The main waste streams from sulphonation processes are:

- exhaust gas, containing SO<sub>2</sub> from oxidation reactions, SO<sub>3</sub> from oleum use, HCl from SOCl<sub>2</sub> use, and VOCs. The loads depend on the reactants (aromatic, H<sub>2</sub>SO<sub>4</sub>, oleum) and the temperature
- contaminated gypsum and CaCO<sub>3</sub> from liming/chalking or Na<sub>2</sub>SO<sub>4</sub> from neutralisation
- mother liquor from the primary product isolation step containing high loads of organic by-products (and lost product), unconverted sulphuric acid, and possibly salt (from salting out or neutralisation)
- wash-water from product washing containing lower concentrations of organic by-product, sulphuric acid and salts
- second filtrate from recrystallisation containing lower concentrations of organic by-product, sulphuric acid and salts
- filter auxiliaries: charcoal, diatomaceous earth, kieselguhr or similar containing organic impurities.

Table 4.33 gives some example data for waste streams from sulphonation and Table 4.34 shows examples for the treatment of waste water streams. Where the loads and the results from Zahn-Wellens testing were available, a refractory COD according to the result of biodegradability testing and dilution to 2000 m<sup>3</sup> effluent was calculated to illustrate the effect on COD concentrations in the discharged waste water.

Figure 4.34 shows the treatment techniques.

Waste stream	Properties
	[15, Köppke, 2000]
SO <sub>2</sub> , SO <sub>3</sub> , HCl, VOC	The loads depend on the reactants (aromatics, H <sub>2</sub> SO <sub>4</sub> , oleum, SOCl <sub>2</sub> ) and temperature When oleum is used: SO <sub>3</sub> up to 35 g/m <sup>3</sup> + SO <sub>2</sub>
Gypsum, Na <sub>2</sub> SO <sub>4</sub> , CaCO <sub>3</sub>	Contaminated
Mother liquor	COD >20000 mg/l BOD <sub>5</sub> 2500 – 4000 mg/l Bioeliminability 30 – 60 % AOX up to 200 mg/l The AOX load depends on the raw materials
Wash-water	COD <1000 mg/l BOD <sub>5</sub> 40 – 100 mg/l Bioeliminability 30 – 60 % AOX up to 20 mg/l The AOX load depends on the raw materials
Second filtrate	
Filter auxiliaries	Charcoal, diatomaceous earth, kieselguhr or similar

**Table 4.33: Example data for waste streams from sulphonation**

The environmental key issue is related to the mother liquor from the primary product isolation step. The mother liquor is a diluted sulphuric acid and contains a high COD load (arylsulphonic acids) and a possibly high AOX load (from halogenated raw materials or SOCl<sub>2</sub> addition).

[51, UBA, 2004]				
Example 1	Mother liquor		Process was modified to continuous mode, acid recovery in an external plant	
	Volume per batch	23 m <sup>3</sup>		
	COD per batch	550 kg		
	AOX per batch	5 kg		
	BOD <sub>5</sub> /TOC	0.06		
		Treatment	COD after degradation and dilution to 2000 m <sup>3</sup> (* see note)	
Example 2	Mother liquor 1		Pretreatment by high pressure wet oxidation	
	Volume per batch	60 m <sup>3</sup>		
	TOC	12 g/l		
	Degradability (Zahn-Wellens)	15 %		
	Mother liquor 2			
	Volume per batch	6 m <sup>3</sup>		
	COD	45 g/l		
	BOD <sub>5</sub>	0.4 g/l		
	Degradability	5 %		
SO <sub>4</sub> <sup>2-</sup>	14 g/l			
Example 3	Waste acid (mother liquor 1)		Recovery in external sulphuric acid plant	
	Mass in tonnes	21		
	H <sub>2</sub> SO <sub>4</sub>	75 %		
	TOC	560 kg		
			Biological treatment	20.5 mg/l
	Mother liquor 2			
	Volume per batch	50 m <sup>3</sup>		
	COD	2.7 g/l		
	BOD <sub>5</sub>	0.28 g/l		
	Degradability	70 %		
AOX	26 mg/l			
SO <sub>4</sub>	70 g/l			
Example 4	Mother liquor		After process optimisation by extraction and re-use	30.8 mg/l
	Volume per day	6 m <sup>3</sup>		
	TOC	3.6 g/l 20 kg/t		
	Degradability	11 %		
Example 5	Cleaning water		Waste water from equipment cleaning, two steps	
	Volume per tonne	4 + 9 m <sup>3</sup>		
	TOC per tonne	3 + 6 kg		
	Degradability	45 %		
* Refractory COD according to the result of bioeliminability testing and dilution to 2000 m <sup>3</sup>				

Table 4.34: Examples for waste water streams obtained from sulphonations

Majority of the arylsulphonic acids are poorly biodegradable and therefore need special pretreatment. The further destiny of the mother liquor depends on the method used for product isolation:

- if the arylsulphonic acid can be precipitated from sulphuric acid solution without neutralisation or salt being added, the spent acid can be recovered in a sulphuric acid plant
- if the mother liquor contains salts (from salting out or neutralisation), advanced wet oxidation processes (e.g. low pressure or high pressure wet oxidation) are possible methods of treatment, which subsequently enable an effective degradation in biological waste water treatment works
- example 3 in Table 4.34 shows a case where waste water stream contains relatively low TOC load, which prevents efficient wet oxidation or incineration and, hence, is only treated in the biological waste water treatment plant (bioeliminability 70 %).

Wash-waters and filtrates from recrystallisation can be re-used for the primary crystallisation step instead of fresh water.

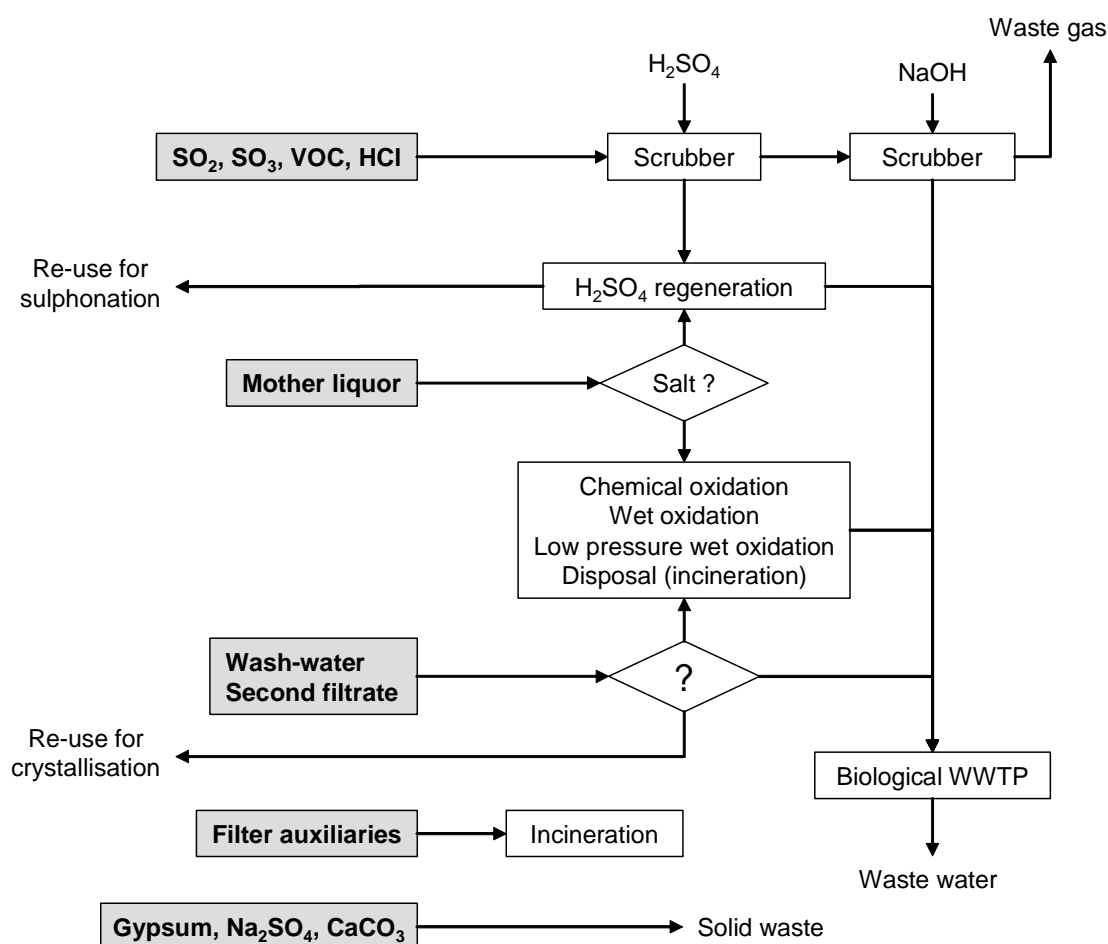

Figure 4.34: Applied abatement techniques for the waste streams from sulphonation

### Achieved environmental benefits

Lower emission levels, and improved efficiency in the case of recovery.

### Cross-media effects

Effects of the recovery/abatement techniques.

**Operational data**

*No information provided*

**Applicability**

Generally applicable.

**Economics**

*No information provided.*

**Driving force for implementation**

Lower emission levels, and improved efficiency in the case of recovery.

**References to literature and example plants**

[16, Winnacker and Kuechler, 1982, 26, GDCh, 2003].

4.3.2.9 Waste streams from sulphonation with  $\text{SO}_3$ 

## Description

The main waste streams from sulphonation with  $\text{SO}_3$  are:

- exhaust gases containing  $\text{SO}_2$ ,  $\text{SO}_3$  and VOCs depending on the individual case
- mother liquor containing  $\text{H}_2\text{SO}_4$  and high COD loads (lost product, by-products)
- wash-water containing lower COD loads (lost product, by-products).

Figure 4.35 shows the applied abatement techniques.

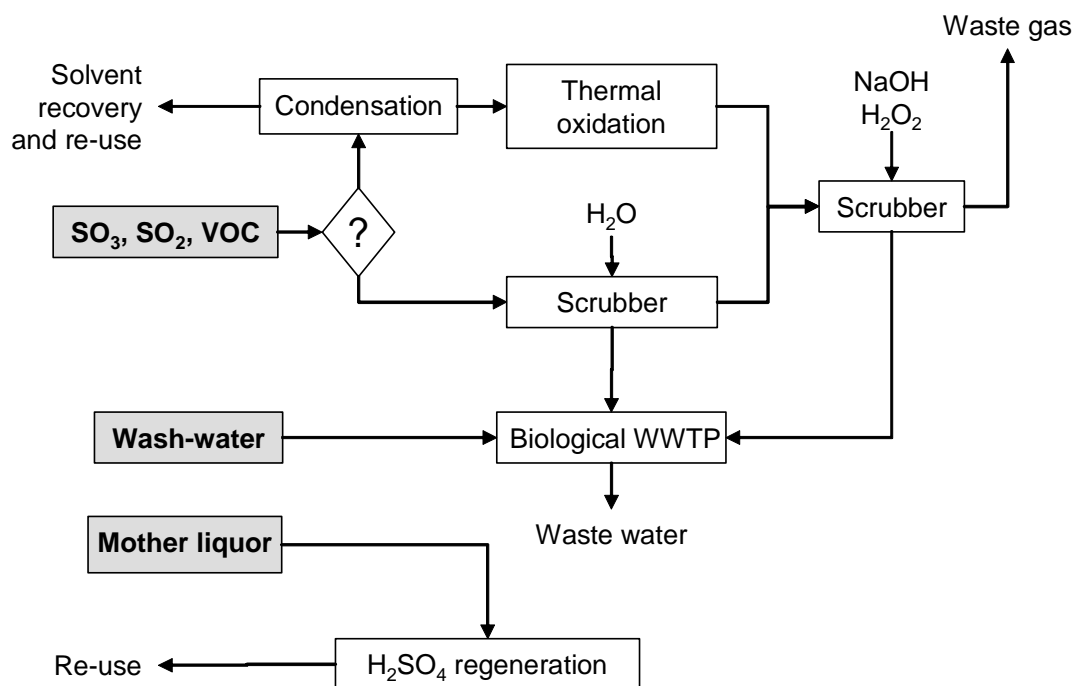

Figure 4.35: Applied abatement techniques for sulphonation with  $\text{SO}_3$

**Exhaust gas.** If halogenated solvents are used, the VOC load of the exhaust gas is passed through a condenser for recovery and subsequently destroyed by thermal oxidation (temperatures of about  $1100\text{ }^\circ\text{C}$  and dwell times of  $1 - 2\text{ s}$ ) followed by treatment of the flue-gas.

If the VOCs are highly water soluble, thermal oxidation is replaced by absorption in a water scrubber.

$\text{SO}_x$  is washed out in a reactive absorber with  $\text{NaOH}/\text{H}_2\text{O}_2$  and converted to  $\text{Na}_2\text{SO}_4$ , which may lead to a high  $\text{SO}_4^{2-}$  load in the total effluent.

**Mother liquor.** Sulphonation with  $\text{SO}_3$  has the advantage that the salt content of the mother liquor is low enough to allow its processing in a sulphuric acid regeneration facility.

**Wash-water** is treated in the biological WWTP.

#### Achieved environmental benefits

Lower emission levels, and improved efficiency in the case of recovery.

**Cross-media effects**

Effects of the recovery/abatement techniques.

**Operational data**

*No information provided.*

**Applicability**

Generally applicable.

**Economics**

*No information provided.*

**Driving force for implementation**

Lower emission levels, and improved efficiency in the case of recovery.

**References to literature and example plants**

[15, Köppke, 2000]

## 4.3.2.10 Waste streams from sulphochlorination

## Description

The main waste streams from sulphochlorination are:

- exhaust gas containing mainly HCl, but also Cl<sub>2</sub>, SO<sub>2</sub> from the use of thionyl chloride or CH<sub>2</sub>Cl<sub>2</sub> from the use as a diluent, and possibly other VOCs, depending on the organic feed
- mother liquors from product filtration or phase separation, containing high COD loads (lost product, by-products) and AOX loads due to unwanted chlorination
- wash-water containing lower loads of COD/AOX due to lost product and the by-products
- distillation residue from the work-up of liquid products.

Table 4.35 gives some example data for the waste streams from sulphochlorination, Figure 4.36 shows the applied abatement techniques.

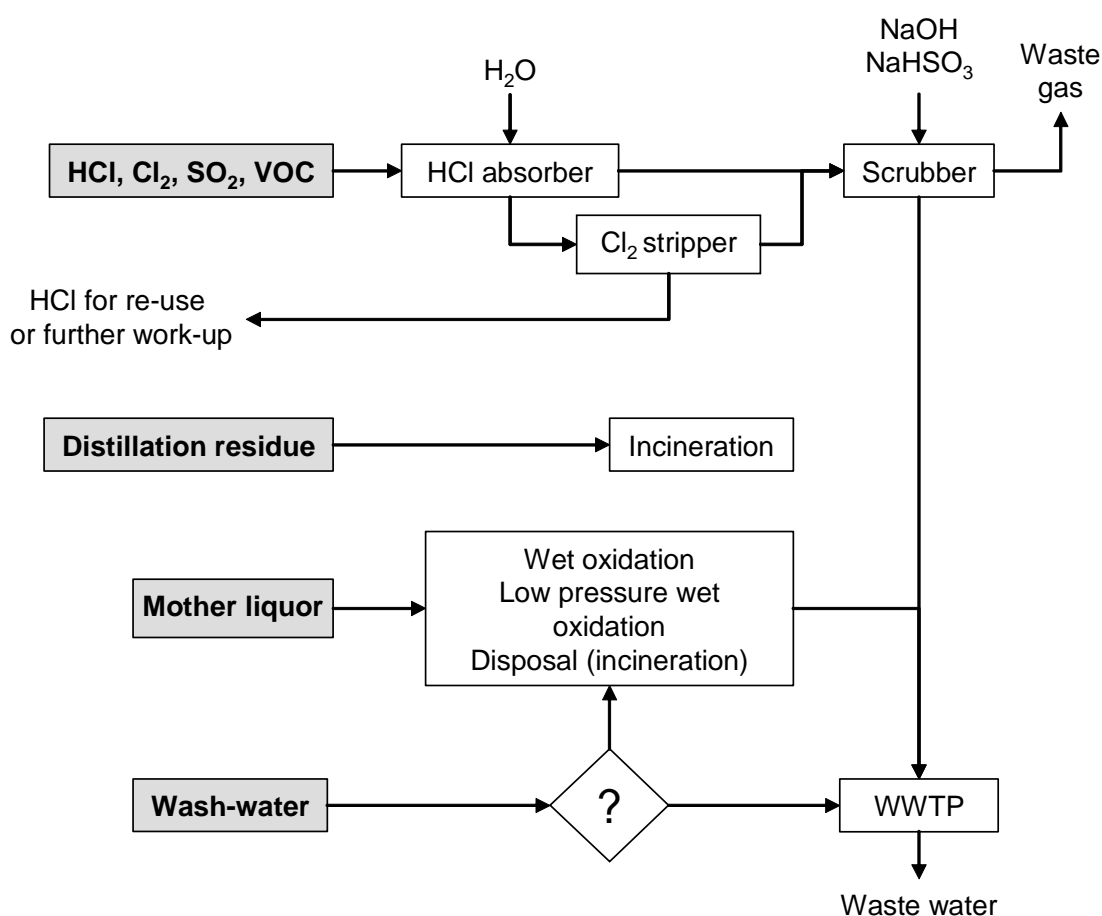

Figure 4.36: Treatment of waste streams from sulphochlorination

**Exhaust gases.** HCl is created in large quantities and recovered, but may be potentially loaded with organic compounds and/or Cl<sub>2</sub> (for more information see Section 4.3.5.2). The contaminants require further work-up steps (e.g. stripping of the chlorine) and use may be restricted in order to prevent the cross-contamination of other processes. The gas stream is finally treated in a reactive scrubber.

The **mother liquors** usually have low biodegradability in combination with high COD/AOX loadings and are treated by wet oxidation, low pressure wet oxidation or incineration.

**Wash-waters** with low refractory loadings are treated in a biological treatment plant.



**Distillation residues** contain various by-products (possibly with higher halogenation degrees) and are incinerated.

Waste stream	Properties	
[15, Köppke, 2000]		
Mother liquor	COD	5000 – 10000 mg/l
	BOD <sub>5</sub>	500 – 2000 mg/l
	Degradability	30 – 60 %
	AOX	up to 40 mg/l

**Table 4.35: Example for a waste stream from sulphochlorination**

#### **Achieved environmental benefits**

Lower emission levels, and improved efficiency in the case of recovery.

#### **Cross-media effects**

Effects of the recovery/abatement techniques.

#### **Operational data**

*No information provided.*

#### **Applicability**

Generally applicable.

#### **Economics**

*No information provided.*

#### **Driving force for implementation**

Lower emission levels, and improved efficiency in the case of recovery.

#### **References to literature and example plants**

[15, Köppke, 2000]

### 4.3.2.11 Waste water streams from fermentation

#### Description

Fermentation processes create various high loaded waste water streams (see also Section 2.6). Table 4.36 shows the example from plant \*009A,B,D\*. All waste water streams show a high degradability of the organic load and are finally treated in a biological WWTP. The critical parameter is the N load, which represents a major challenge for a central biological WWTP. Hence, strategies, such as decentralised anaerobic treatment and removal of compounds containing N, are applied. In the case of \*009A,B,D\* an additional nitrification stage prior to centralised biological treatment is under construction.

#### Achieved environmental benefits

Lower emission levels, and improved efficiency in the case of recovery.

#### Cross-media effects

Effects of the recovery/abatement techniques.

#### Operational data

See also Table 4.36.

#### Applicability

Generally applicable.

#### Economics

*No information provided.*

#### Driving force for implementation

Lower emission levels, and improved efficiency in the case of recovery.

#### References to literature and example plants

[91, Serr, 2004, 99, D2 comments, 2005], \*009A,B,D\*

Waste water stream		Downstream treatment	Volume	COD		Bioeliminability	BOD <sub>5</sub>		NH <sub>4</sub> -N	NaOH	Urea	PO <sub>4</sub>
			m <sup>3</sup> /day	g/l	t/day	%	g/l	t/day	t/day	t/day	t/day	t/day
a	Distillation residue from propanol separation	<ul style="list-style-type: none"> <li>anaerobic pretreatment and subsequent aeration prior to central biological waste water treatment</li> <li>decentralised nitrification in construction</li> <li>deactivation of GMOs with cresol (biocide), the resulting cresol concentrations do not influence the biological treatment stage</li> </ul>	362	11	4	96	6	2.3	0.21			
b	Solutions from regeneration of the chromatography		15		2.3	98		2.5		0.55		
c			11		3.3	99		1.4		0.40		
d	Central scrubbing of exhaust gases		95	23	2.2	98	19	1.8				
e	Fermentation broth after removal of the cell mass		26	58	1.7	99	29	0.8	0.17			0.10
f	Cell destruction and centrifugation		70		1.1	98		0.8		0.03		0.00
g			64		0.3	96		0.2	0.01			0.00
h	Permeate after chromatography	Separation of urea with an evaporator, biological waste water treatment	145	16	2.3	95					4.4	

Table 4.36: Examples for the waste water streams from a fermentation unit

### 4.3.3 Recovery of aromatic solvents and lower alcohols

#### Description

Aromatic solvents such as toluene and lower alcohols such as methanol represent by far the majority of the bulk solvents used in the OFC sectors and the value of toluene especially justifies the efforts for recovery. Most frequently the following tasks occur:

- the product is present in toluene solution. Toluene is recovered and purified in a packed column followed by the separation of a toluene/water mixture (see Figure 4.37)
- after product separation, a mixture of toluene and methanol is obtained. Toluene and methanol are recovered by discontinuous distillation as an azeotrope which is separated by the addition of water into a toluene and a methanol/H<sub>2</sub>O phase. The latter is distilled continuously to give methanol (see Figure 4.38)
- toluene is recovered from exhaust gases (see Figure 4.39)
- toluene/methanol mixtures are recovered from exhaust gases (see Figure 4.40).

#### Achieved environmental benefits

- recovery of valuable material
- lower emissions
- emission levels for toluene <100 mg/m<sup>3</sup>.

#### Cross-media effects

- energy consumption for distillation, steam creation and cooling
- cooling water consumption, and the activated carbon needs recycling.

#### Operational data

5 and 25 °C cold traps: toluene input of about 500 g/m<sup>3</sup>  
toluene output of about 51 g/m<sup>3</sup>.

#### Applicability

Generally applicable in the case of recovery from exhaust gases.

Recovery is not viable on sites, where already a high quantity of waste solvents is available [99, D2 comments, 2005].

Purification of spent solvents only makes sense if a re-use or a market option is available.

Purity requirements may restrict the re-use or recycling options for solvents/by-products, e.g. in the manufacture of APIs.

### **Economics**

The economic viability of the recovery of a solvent depends on:

- the comparison of operating costs and market price if you already have the recovery facilities
- the payback time for the investment if you have to establish the recovery facilities first.

### **Driving force for implementation**

Cost benefits.

### **References to literature and example plants**

[9, Christ, 1999]

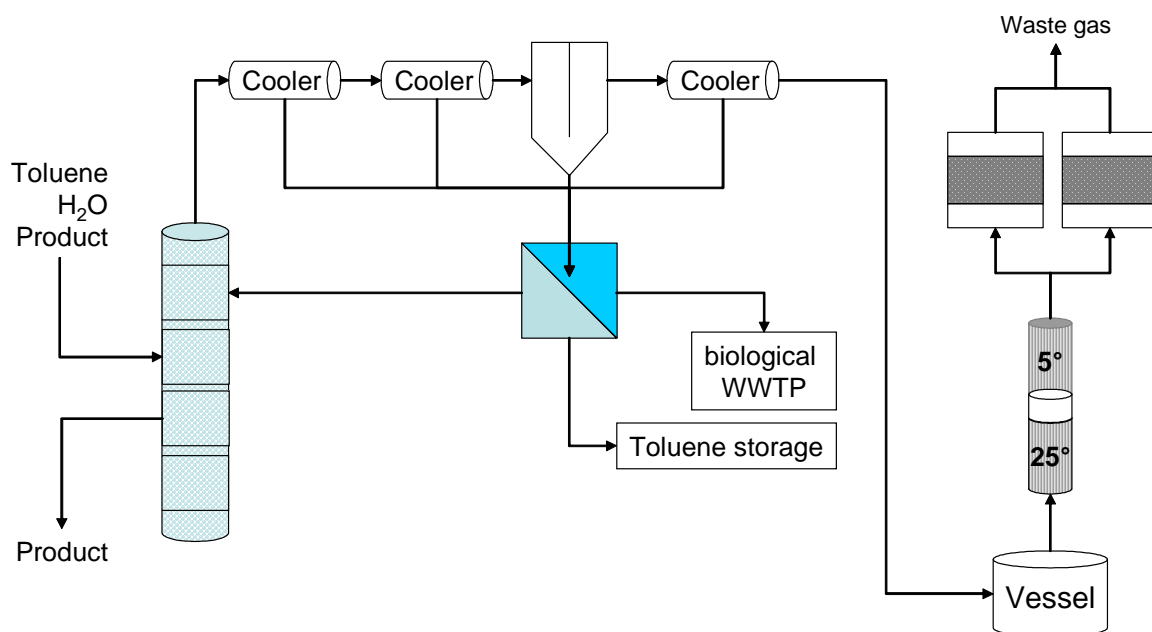

Figure 4.37: Toluene recovery

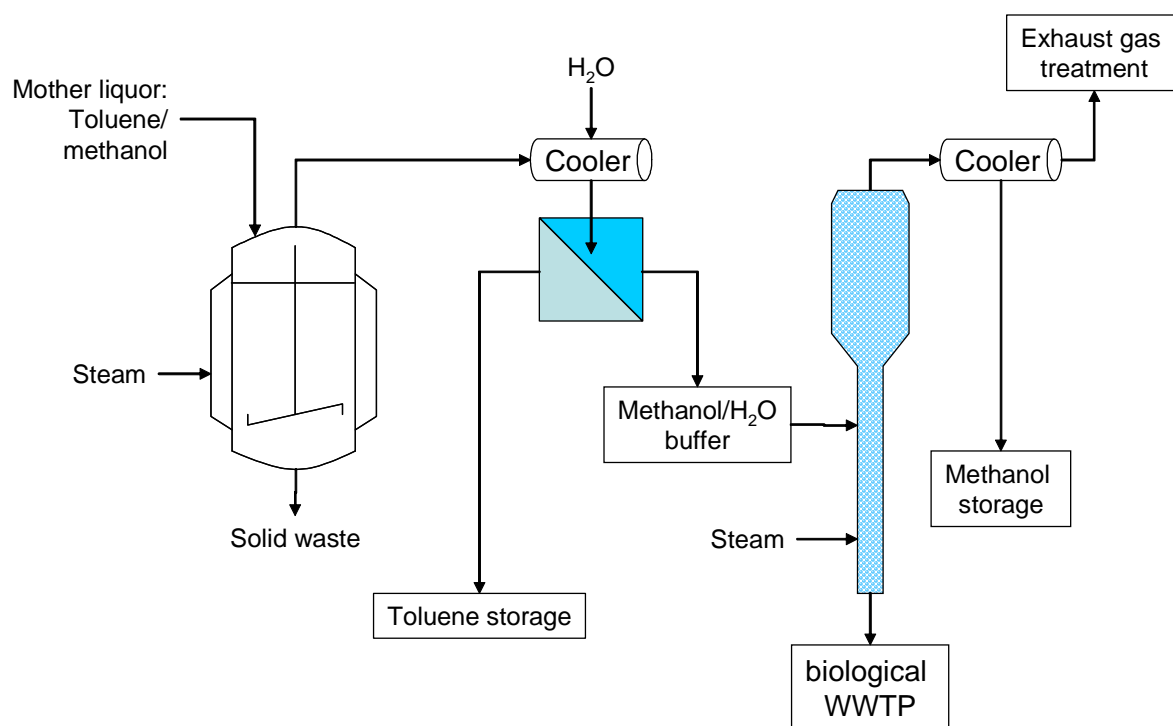

Figure 4.38: Recovery and separation of a toluene/methanol mixture

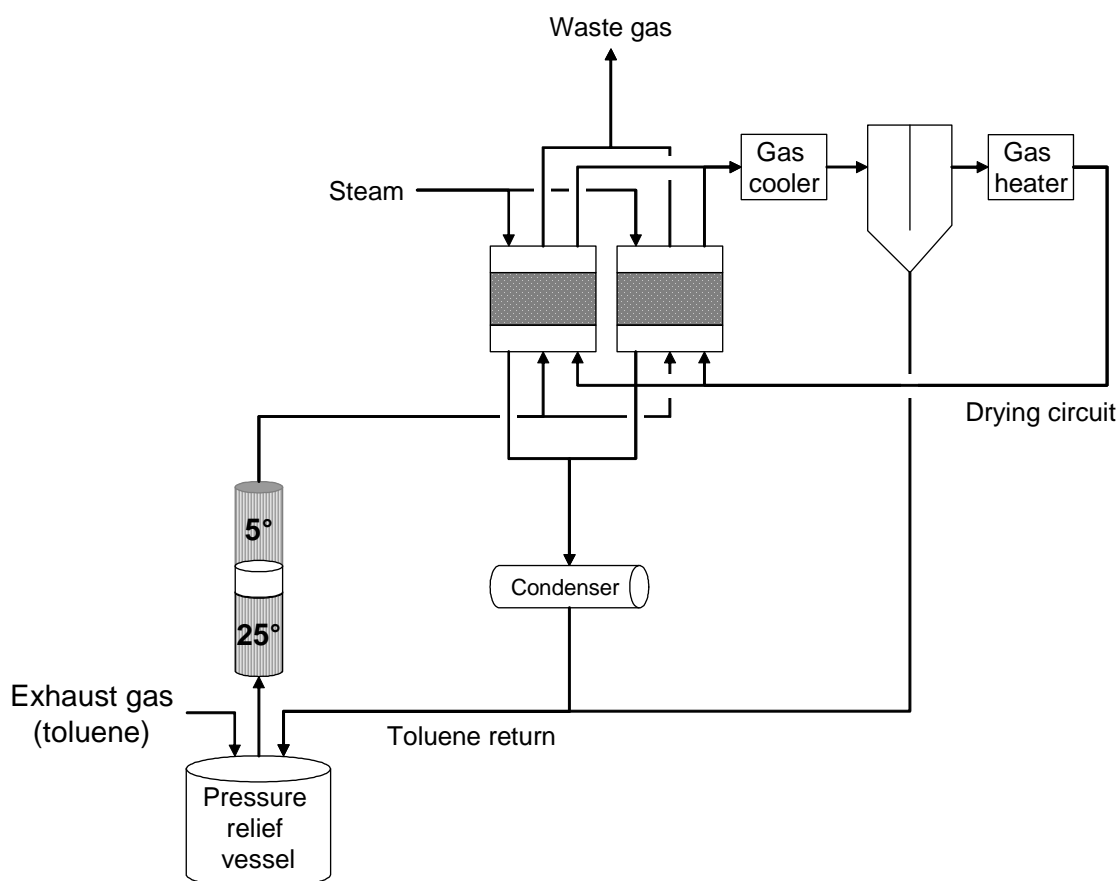

Figure 4.39: Toluene recovery from exhaust gases

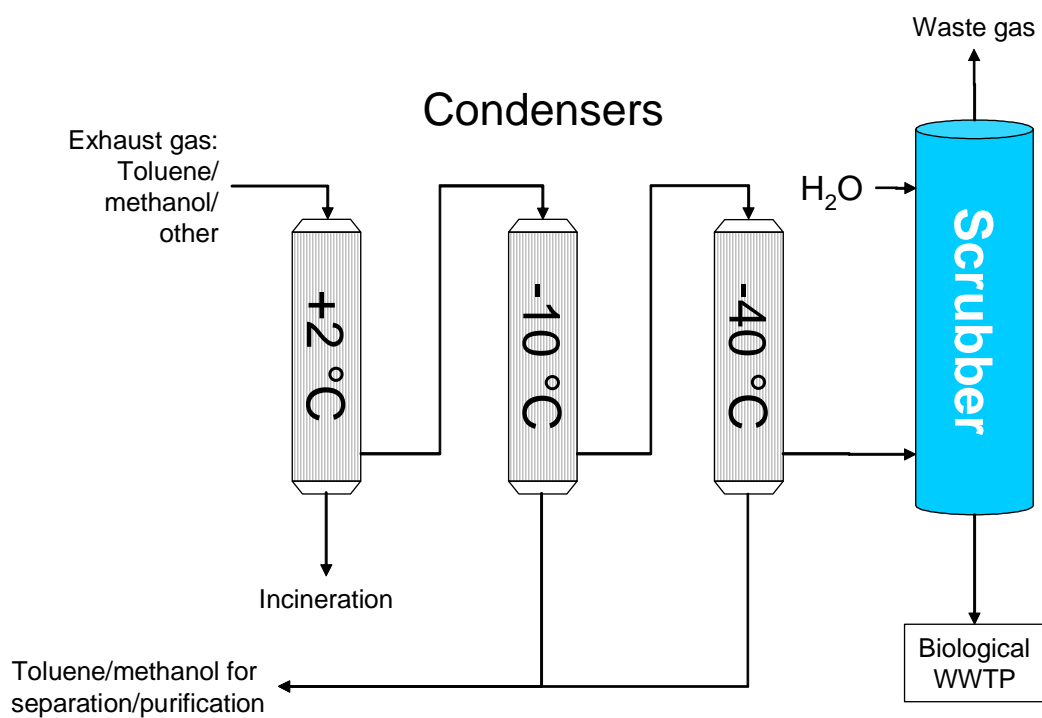

Figure 4.40: Recovery of a toluene/methanol mixture from exhaust gases

### 4.3.4 Re-use and recycling of solvents and by-products

#### **Description**

Whenever possible, re-use and recycling of by-products reduces waste treatment loads and the associated emissions. A common example is to re-use the solvents distilled from a previous batch into the next batch.

#### **Achieved environmental benefits**

Reduction of waste treatment load and associated emissions.

#### **Cross-media effects**

Energy consumption for distillation.

#### **Operational data**

*No information provided.*

#### **Applicability**

Generally applicable.

Purity requirements may restrict the re-use or recycling options for solvents/by-products in the manufacture of APIs.

#### **Economics**

Cost benefits through lower disposal charges.

#### **Driving force for implementation**

Cost optimisation and environmental benefits.

#### **References to literature and example plants**

[62, D1 comments, 2004]



### 4.3.5 Treatment of exhaust gases

#### 4.3.5.1 Recovery of NO<sub>x</sub> from exhaust gases

##### Description

On sites for the manufacture of explosives, nitration is the major unit process. The recovery of spent acids is very important for the control of the costs.

To concentrate nitric acid, water is removed by countercurrent extraction with 92 – 95 % H<sub>2</sub>SO<sub>4</sub>. At the top, 98 – 99 % HNO<sub>3</sub> is produced. At the bottom, 63 – 68 % H<sub>2</sub>SO<sub>4</sub> is obtained, which can be concentrated to 93 % by stripping with combustion gases, or to 96 – 98 % by vacuum distillation. Nitric acid can also be concentrated by distillation over magnesium nitrate. Sulphuric acid is freed of nitric acid and nitro compounds by heating or steam injection [6, Ullmann, 2001].

NO<sub>x</sub> is recovered from exhaust gases from the reaction, feed tanks, centrifugation and buffers by scrubbing (see Figure 4.41). The first three absorption towers are operated with water, the last with H<sub>2</sub>O<sub>2</sub>. H<sub>2</sub>O<sub>2</sub> is used to oxidise NO:

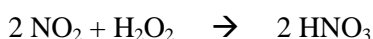

This improves the absorption efficiency drastically and the emitted NO<sub>x</sub> consists of >98 % NO<sub>2</sub>.

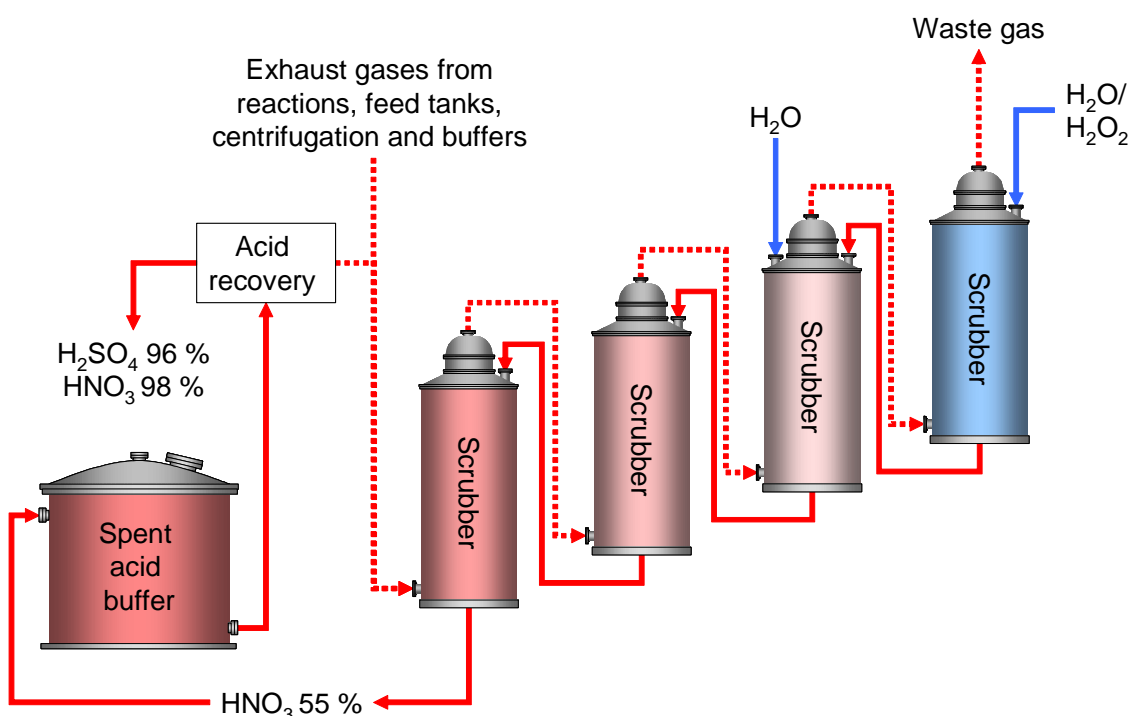

Figure 4.41: Recovery of NO<sub>x</sub> from exhaust gases with a scrubber cascade

##### Achieved environmental benefits

- efficient recovery of NO<sub>x</sub> from exhaust gases
- lower emission levels.

### Cross-media effects

Energy and H<sub>2</sub>O<sub>2</sub> consumption.

Emitted NO <sub>x</sub>	
kg/hour	mg/m <sup>3</sup>
0.87 – 1.69	113 – 220

**Table 4.37: NO<sub>x</sub> emissions from the recovery of NO<sub>x</sub> from exhaust gases**

### Operational data

- volume flow to scrubber cascade: 7700 m<sup>3</sup>/hour
- scrubbing medium: H<sub>2</sub>O<sub>2</sub> 15 %.

### Applicability

Generally applicable.

### Economics

Cost benefits.

### Driving force for implementation

See Achieved environmental benefits.

### References to literature and example plants

\*098E\*, \*099E\*

### 4.3.5.2 Recovery of HCl from exhaust gases

#### Description

HCl is recovered from the flue-gas created by the thermal oxidation of exhaust gases from chlorination processes. The flue-gas still contains chlorine which is separated from the obtained aqueous HCl and treated in a second (final) absorption stage (see Figure 4.42).

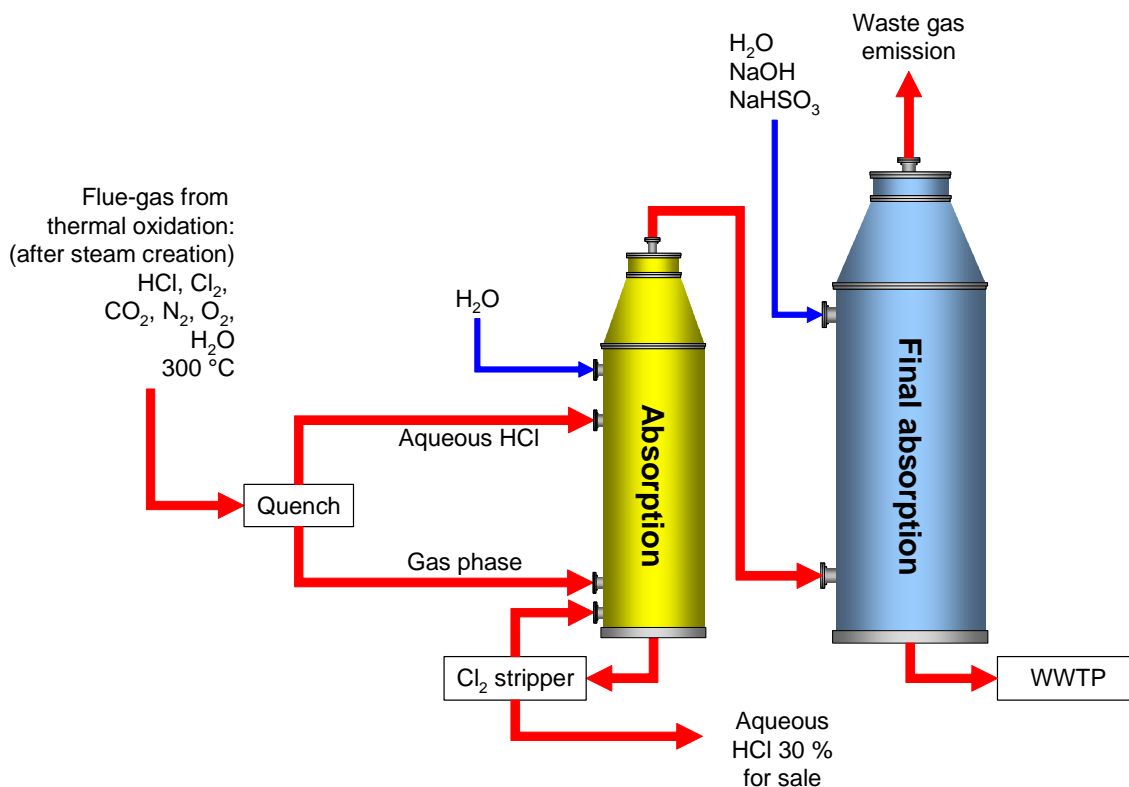

Figure 4.42: HCl recovery from flue-gas

#### Achieved environmental benefits

- 99.95 % recovery of HCl from the exhaust gas stream
- saving of NaOH for neutralisation
- through the thermal oxidation step, the recovered HCl is pure enough for sale
- the benefits from HCl recovery favour the installation of the thermal oxidiser with high VOC destruction performance
- the achieved emission values are given in Table 4.38.

Parameter	Units	[15, Köppke, 2000]
org. C	mg/m <sup>3</sup>	<3.1 – 9.0
CO	mg/m <sup>3</sup>	<5
HCl	mg/m <sup>3</sup>	<2.4 – 4.4
Cl <sub>2</sub>	mg/m <sup>3</sup>	<0.1
SO <sub>x</sub>	mg/m <sup>3</sup>	<0.6
NO <sub>x</sub>	mg/m <sup>3</sup>	<0.012
Particulates	mg/m <sup>3</sup>	1.2 – 3.8
Dioxins	ng/m <sup>3</sup>	0.083 – 0.09

Table 4.38: Achieved waste gas emission levels after recovery of HCl

Parameter	Units	[15, Köppke, 2000]
Volume	m <sup>3</sup> /d	111
NaOH	mg/l	4226
Filterable substances	mg/l	19
DOC	mg/l	17
COD	mg/l	17
Cl	mg/l	18500
SO <sub>4</sub>	mg/l	11100
NH <sub>4</sub> -N	mg/l	<0.2
NO <sub>2</sub> -N	mg/l	<0.2
NO <sub>3</sub> -N	mg/l	1.2
P total	mg/l	0.4
AOX	mg/l	<0.5
Methanol	mg/l	<0.3
Acetone	mg/l	<0.1
CCl <sub>4</sub>	μg/l	<0.3
o-dichloro benzene	μg/l	<2.3
o-chloro toluene	μg/l	<1.1
p-chloro toluene	μg/l	<1.2
toluene	μg/l	<1
o-xylene	μg/l	<1.1
p-xylene	μg/l	<1.8

**Table 4.39: Achieved waste water output levels from the final absorption stage**

### Cross-media effects

No cross-media effects in comparison with conventional absorption.

### Operational data

Input to quench	Units	[15, Köppke, 2000]
Volume flow	m <sup>3</sup> /h	About 3000
Oxygen	kg/h	298
Nitrogen		2458
CO <sub>2</sub>		321
HCl		710
Cl <sub>2</sub>		57
H <sub>2</sub> O		253

**Table 4.40: Mass flow to the HCl recovery system**

## Applicability

Applicable for all HCl rich exhaust gas streams, such as:

- halogenations
- sulphochlorinations
- phosgenations
- esterifications with acid chlorides
- or comparable processes.

Due to the azeotrope at 20.4 % HCl, the production of concentrated hydrochloric acid from a gas stream with a low hydrogen chloride concentration requires a comparatively higher effort because either the pressure must be increased, the temperature reduced, or both [62, D1 comments, 2004].

## Examples

- \*085B\*: recovery of HCl from an exhaust gas stream from esterification with  $\text{SOCl}_2$  [68, Anonymous, 2004]
- \*069B\*: recovery of HCl from an exhaust gas stream from chlorination with  $\text{SOCl}_2$ , the recovered HCl is re-used on-site

## Economics

- presumed that the exhaust gas would have been treated anyway, only the cost benefit from sale of the recovered HCl is taken into account (see Table 4.41)
- saving of NaOH for neutralisation.

Operating hours per year	6000
Recovered HCl (30 %), kg per hour	2279
Price per kg HCl (30 %)	EUR 0.05 (DEM 0.1)
Cost benefit per year	EUR 699000 (DEM 1368000)

**Table 4.41: Cost benefits from HCl recovery**

## Driving force for implementation

Cost benefits.

## References to literature and example plants

[15, Köppke, 2000] \*085B\*

### 4.3.5.3 Scrubbing of HCl from exhaust gases and related emission levels

#### Description

Figure 4.43 and Figure 4.44 show HCl emission values (concentrations and mass flows) from point sources (vertical bars represent maximum and minimum values). The presented data are taken from Table 3.2 and Table 3.1. The obtained data show the following characteristics:

- emissions via one or more scrubbers with different scrubbing media (e.g. H<sub>2</sub>O, NaOH)
- 13 of 21 references report emission concentrations for HCl of 1 mg/m<sup>3</sup> or lower
- chemical processes (especially chlorination) may cause higher concentrations, but can be operated with low mass flows.

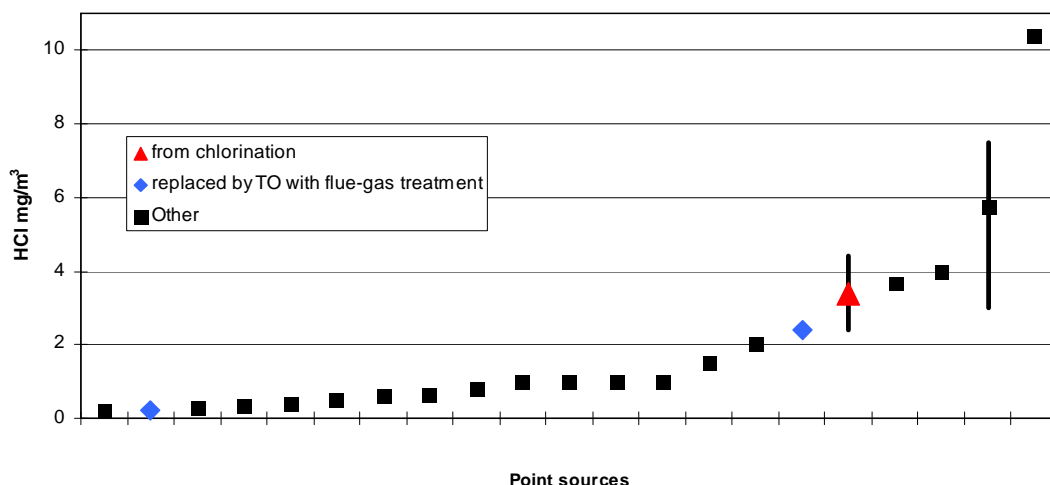

Figure 4.43: Concentration values for HCl emissions from point sources

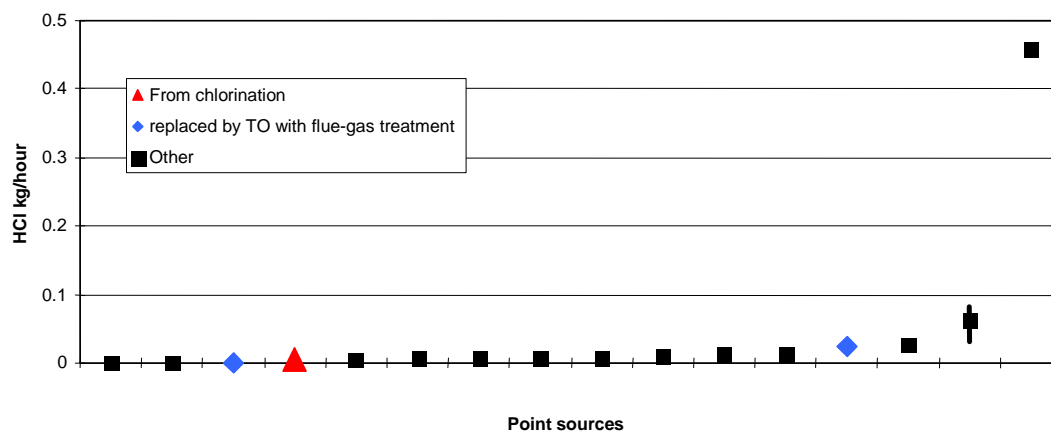

Figure 4.44: Mass flow values for HCl emissions from point sources

#### Achieved environmental benefits

Removal of HCl from exhaust gases, and lower emission levels.

#### Cross-media effects

Water and chemical consumption.

**Operational data**

*No information provided.*

**Applicability**

Generally applicable. Scrubbers are standard equipment.

**Economics**

*No information provided.*

**Driving force for implementation**

HCl emission levels.

**References to literature and example plants**

All reference plants apply scrubbing.

## 4.3.5.4 Recovery of bromine and HBr from exhaust gases

## Description

Bromination processes generate a number of gaseous effluent streams containing hydrogen bromide and bromine, which are scrubbed prior to emission to the air. In addition, bromine rich air streams are displaced during the filling of bromine storage and day tanks, and during the depressurisation of the storage and isotank delivery vessels which are discharged by a moderate dry compressed air overpressure. The plant areas within the process building are provided with both general and local extraction ventilation. The possibility of leakage into those areas of bromine species requires the extract air to be scrubbed prior to discharge to the air.

A linked series of scrubbing systems are in place to recover/remove hydrogen bromide, bromine and possible traces of volatile brominated and other organic compounds from the process vents and extract ventilation streams of the bromination plant. Figure 4.45 illustrates the setup on the \*007I\* site.

The final hydrobromic acid solution concentration of 46 % w/w HBr is chosen together with the combined capacity of the duty and standby base tanks, to allow absorption of all hydrogen bromide produced during a minimum of one reactor batch.

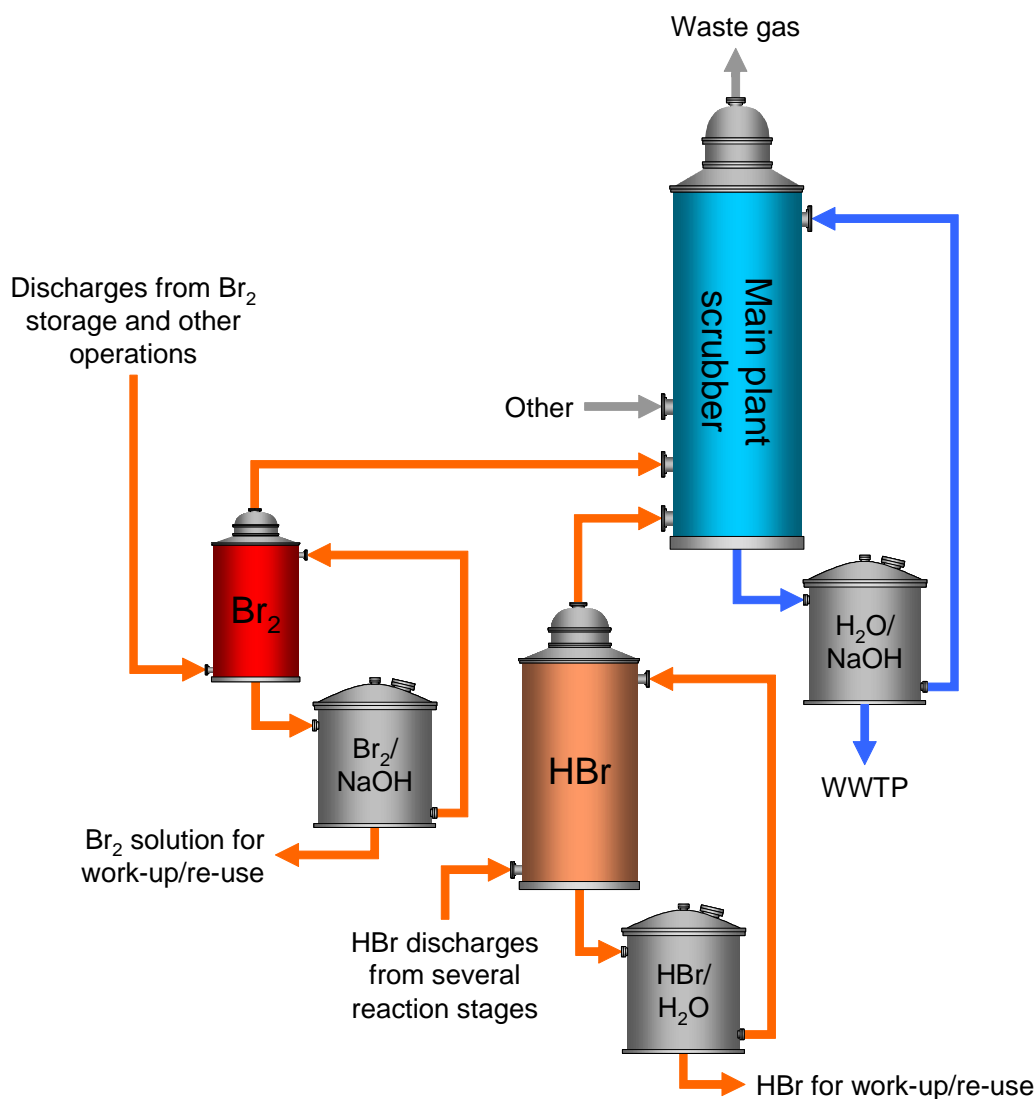

Figure 4.45: Scrubbing system for recovery/removal of HBr and Br<sub>2</sub>



### Achieved environmental benefits

Recovery of valuable material for re-use/sale instead of emission to air or water.

Table 4.42 shows the emissions to air for the example from \*007I\*.

*007I*	After main scrubber (annual mean for 2002)	
	mg/m <sup>3</sup>	kg/hour
<b>Br<sub>2</sub></b>	1.6	0.007
<b>HBr</b>	below detection limit	
<b>Organic bromides</b>	20.0	0.1

**Table 4.42: Emissions from a HBr/Br<sub>2</sub> recovery/removal system**

### Cross-media effects

No cross-media effects in comparison with conventional absorption.

### Operational data

For mass flows to the scrubbers, see Table 4.30.

### Applicability

- applicable for all HBr rich exhaust gas streams (in the given example, 11350 kg HBr and 750 kg Br<sub>2</sub> per batch)
- HBr obtained from a scrubber may also contain an organic load which may need purification before re-use/sale.

### Economics

- presumed that the exhaust gas would have been treated anyway: cost benefit from re-use/sale of the recovered HBr
- saving of NaOH for neutralisation.

### Driving force for implementation

Cost benefits.

### References to literature and example plants

[75, Trenbirth, 2003], \*007I\*

### 4.3.5.5 Absorption of excess chlorine from exhaust gases

#### Description

Chlorine loads in the exhaust gases from chlorinations can be absorbed by reaction with the organic feedstock in the presence of UV light (see Figure 4.46). The partially halogenated organic feed is stored for the next batch or fed to the continuous process.

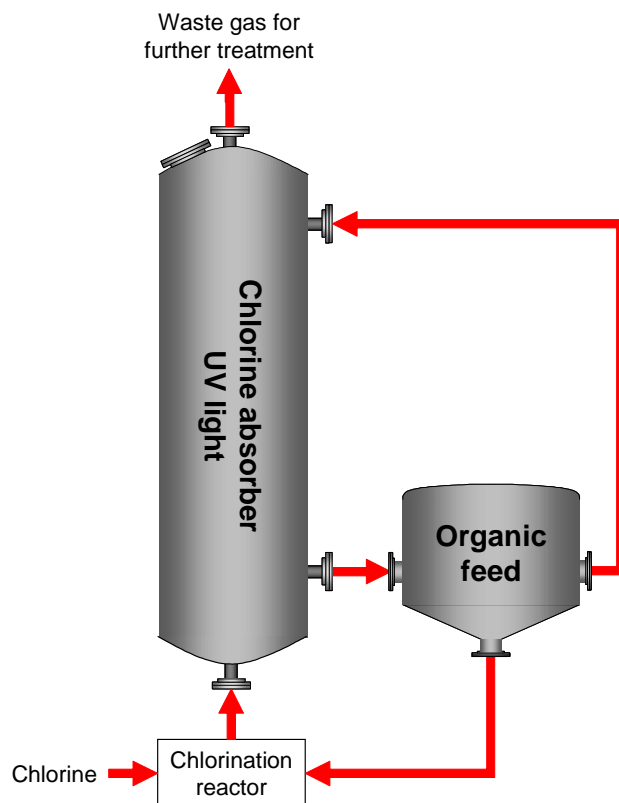

Figure 4.46: Absorption of excess chlorine

#### Achieved environmental benefits

- absorption and re-use of about 80 % of the chlorine load from strong streams
- relief of downstream techniques.

#### Cross-media effects

*None believed likely.*

#### Operational data

*No information provided.*

#### Applicability

Applicable for the halogenation of aliphatic compounds.

**Economics**

*No information provided.*

**Driving force for implementation**

Effective use of chlorine, and relief of downstream techniques.

**References to literature and example plants**

[15, Köppke, 2000]

## 4.3.5.6 Condensation of VOCs from reactors and distillations

**Description**

The condensation of VOCs from reactors or distillations is carried out by indirect cooling of highly loaded exhaust gases before downstream exhaust gas treatment, followed by separation of the gas and liquid phase. Depending on the situation (e.g. reflux process or required temperature profile of the distillation column), the condensate is subsequently fed back to the process or stored for re-use. Figure 4.47 gives an overview. The number of cooling steps and the applied temperature(s) depend on the particular solvent.

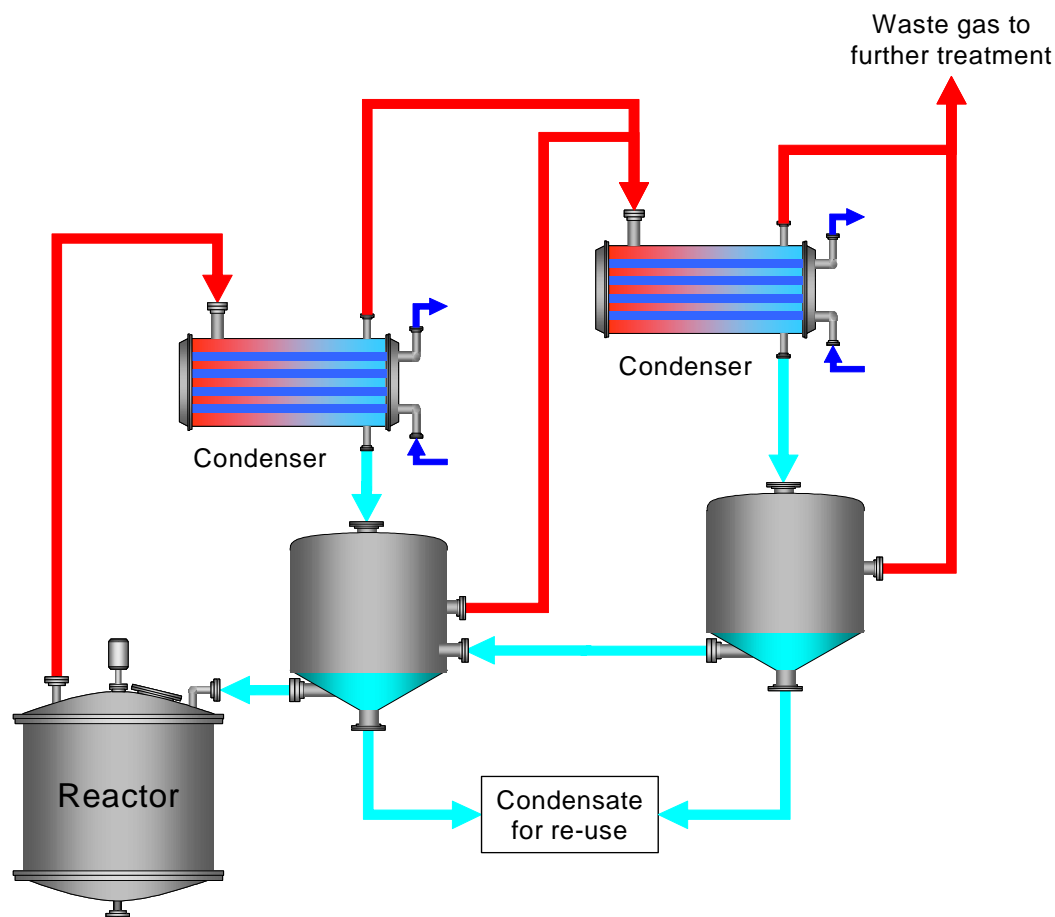

**Figure 4.47: Two stage condensation from a reactor**

**Achieved environmental benefits**

- reduction and recycling of the VOC load at source before mixing with other exhaust gas streams
- performance: 70 – 95 % (depending on the particular case)
- reduced downstream abatement capacity required.

**Cross-media effects**

Shift of pollutants from the waste gas path to the liquid phase.

### Operational data

- usually indirect cooling with ice or different brine types, or using oil as a medium
- required temperatures:  
[15, Köppke, 2000]: solvents such as toluene or i-butanol mostly below -50 °C  
[68, Anonymous, 2004]: for toluene two steps a) chilled water 5 °C, b) brine -25 °C  
[9, Christ, 1999]: for toluene a) 25 °C, b) 5 °C followed by activated carbon adsorption.

### Applicability

Applicable for all normal solvents.

Restrictions may occur in high humidity environments due to geographical location or with exhaust gases containing moisture, especially in the case of cryogenic condensation [62, D1 comments, 2004], [99, D2 comments, 2005].

### Economics

- usually low capital costs
- usually low operating costs.

Capital/operating costs may be high, depending on the volatility of the solvent and the cooling medium required.

### Driving force for implementation

Temperature adjustment, to save downstream abatement capacity, and ELVs (VOC Directive).

### References to literature and example plants

[15, Köppke, 2000], \*002A\*, \*003F\*, \*006A,I\*, \*017A,I\*, \*018A,I\*, \*019A,I\*, \*020A,I\*, \*022F\*, \*023A,I\*, 037A,I

### 4.3.5.7 Thermal oxidation of VOCs and co-incineration of liquid waste

#### Description

The multipurpose production of organic chemicals requires both flexibility concerning the applied processes and the safe control of waste streams. The waste gas abatement system has to cope with hydrocarbons and compounds containing nitrogen, chlorine, bromine or sulphur including frequent changes of loadings. One possible solution is to apply the thermal oxidation of waste gases in combination with the incineration of liquid waste streams. The thermal oxidiser/incinerator is able to handle:

- peak VOC gases
- peak organic liquid waste
- peak low calorific values
- natural gas as support fuel.

It is able to handle all these inputs simultaneously. Setting an appropriate combustion temperature and dwell time allows the input of halogenated compounds. VOC lean, odorous streams, e.g. from the on-site waste water treatment plant, serve as combustion air. A modular plant setup is shown in Figure 4.48 [34, Schwarting, 2001].

- (1) waste gas collection system with shock fans, static flame filters and dynamic flame barriers
- (2) combustion unit with DeNO<sub>x</sub> function and waste heat boiler for steam production
- (3) storage tanks for NH<sub>3</sub> (DeNO<sub>x</sub>), scrubbing media (NaOH, NaS<sub>2</sub>O<sub>3</sub>)
- (4) acid gas and halogen removal system
- (5) plume suppression system

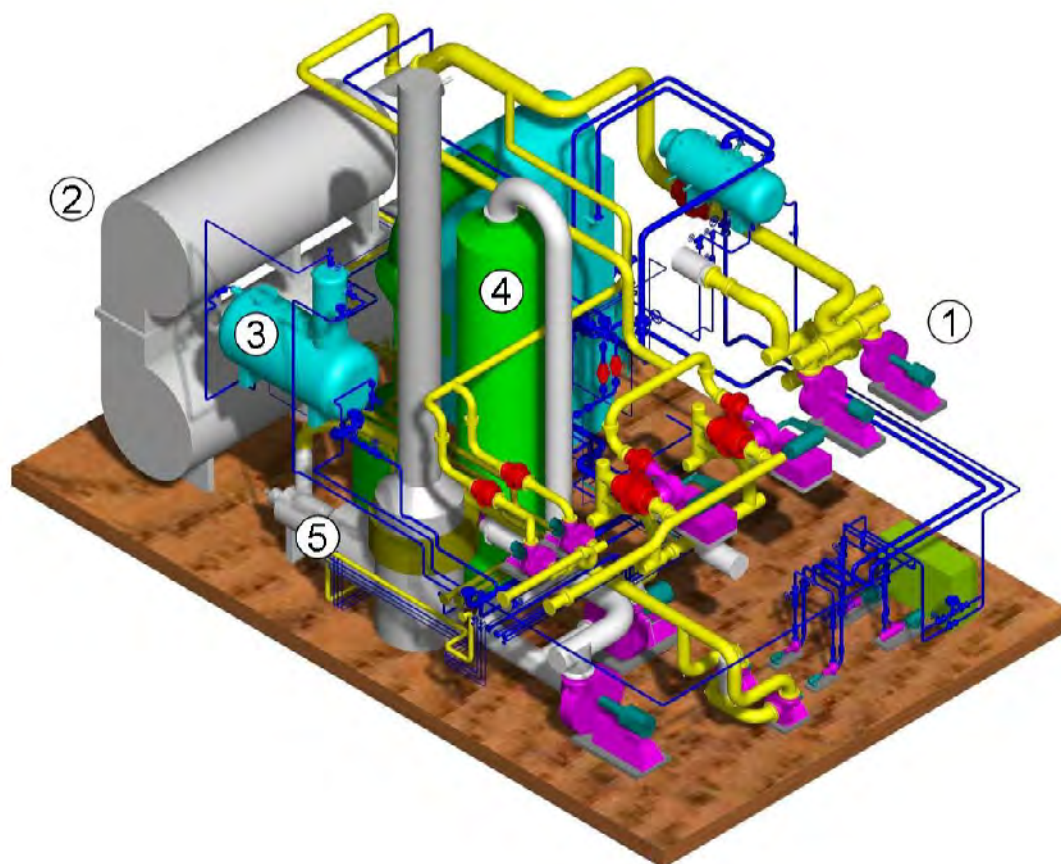

Figure 4.48: Modular thermal treatment plant for waste gases and liquid wastes

### Achieved environmental benefits

- VOC destruction efficiencies of up to 99.99 %. The achievable emission levels are shown in Table 4.43.

Parameter	Unit	[34, Schwarting, 2001]	*019A,I*	
			Nitrogenous solvent loading test	Dioxin sampling
org. C	mg/m <sup>3</sup>	<1	0.6	0.8
CO	mg/m <sup>3</sup>	<1	17	19
HCl/Cl <sub>2</sub>	mg/m <sup>3</sup>	<5	0.37	0.51
HBr/Br <sub>2</sub>	mg/m <sup>3</sup>	<5		
SO <sub>x</sub>	mg/m <sup>3</sup>	<20	0.08	0.09
NO <sub>x</sub>	mg/m <sup>3</sup>	<80	25	26
NH <sub>3</sub>	mg/m <sup>3</sup>		0.71	0.77
DeNO <sub>x</sub> efficiency	%	up to 97	96.08	
Dioxins	ng/m <sup>3</sup>	<0.05		<0.001
		Guaranteed values	Test sampling	

**Table 4.43: Achievable emission levels for thermal waste gas treatment**

- reduction of primary energy consumption in the case of a high calorific input
- disposal option for non-recoverable liquid wastes and low calorific value aqueous streams which are unsuitable for biological waste water treatment
- no emission peaks.

For more information, see also Table 3.1, Table 3.2 and Sections 4.3.5.18 and 4.3.5.19.

### Cross-media effects

- no shift of organic loadings to the waste water pathway
- higher energy consumption when the calorific input is low
- TDS levels and solid residues from incineration have to be considered.

#### with co-incineration of liquid wastes:

- relief of the biological WWTP of toxic/low degradable loadings
- on-site disposal avoids the need to transport of hazardous wastes
- substitution of primary energy.

### Operational data

- about 500 kg/hour liquid wastes
- DeNO<sub>x</sub> unit: 950 – 1000 °C (SNCR) or SCR.

### Applicability

Thermal oxidation is a proven method for destroying VOCs and especially hazardous air pollutants, operating at the highest efficiencies and suitable for almost all VOC sources, including process vents, storage tanks, material transfer operations, treatment, storage and disposal facilities. Table 4.44 gives an overview to the limits/restrictions.

Depending on the individual situation, additional options may be realised:

- two-stage burner for exhaust gases with low oxygen concentration containing nitrogenous compounds [99, D2 comments, 2005]
- particulate removal, e.g. a wet electrostatic precipitator “WESP”, \*020A,I\*
- HCl or HBr recovery (see also Sections 4.3.5.3 and 4.3.5.4)
- systems with an inert header and an automatic interlock to the oxidiser unit can be operated up to 50 % LEL.

	Limits/restrictions
Typical gas flows	90 – 86000 m <sup>3</sup> /h
Temperature	750 – 1200 °C
VOC concentration in exhaust gases	<25 % LEL
Dwell times	0.5 – 2 seconds
Reference	[31, European Commission, 2003]

**Table 4.44: Overview to limits and restrictions of thermal exhaust gas treatment**

Example from \*093A,I\*:

- insensitive to variations of pollutants
- low support fuel consumption, autothermal above 2 g/m<sup>3</sup> organic C
- low operating costs.

#### Restrictions:

Exhaust gases like hydrogenation vents; streams containing elevated concentrations of silanes; ethylene oxide sterilisation vents; etc should not be connected to a thermal oxidiser unit, due to safety concerns or the potential negative effect on the functionality of the process equipment [99, D2 comments, 2005].

#### **Economics**

The economic balance depends on the individual case. Table 4.45 gives an overview. Incineration of liquid wastes (unrecoverable solvents) and the simultaneous generation of process steam (substitution of primary energy) can lead to a quick return on investments [34, Schwarting, 2001]. HCl or HBr, if recovered after combustion, are not contaminated with organic compounds and can be directly marketed.

	Economic cost	Economic benefit
<b>Investment</b>	Capital cost	
<b>Operation</b>	Support fuel	Steam generation
		Saved disposal costs
		Waste water treatment costs
		HX recovery

**Table 4.45: Overview to economic costs and benefits of thermal waste gas treatment**



Spent solvents are burned in an incinerator to prevent transportation to waste disposal and to prevent unnecessary consumption of natural gas. Natural gas is, in this case, only used to bring the incinerator to the required temperature. The capacity for the burning of spent solvents is based on the fact that the LEL for VOC concentration should not be exceeded. A calculation is carried out according to Table 4.46 [62, D1 comments, 2004].

On the \*038F\* site, the incinerator is designed to burn about 300 kg spent solvents/hour (combustion factor = 40 MJ/kg). This saves 400 m<sup>3</sup> natural gas/hour. In a year, 2500 tonnes spent solvents are burned in the incinerator, which saves in total 3300000 m<sup>3</sup> natural gas/year. Using EUR 0.134/m<sup>3</sup> as the price of natural gas, savings are above EUR 440000/year. Burning spent solvent involves lower operational costs and, therefore, allows payback on the investment pledged. The incinerator also produces 50 % of the steam needed on the site.

Capacity for spent solvent burning	60 litre/hour
Combustion factor for spent solvents	45 MJ/kg
Density of spent solvents burned	0.8 kg/litre
Combustion factor for natural gas	31 MJ/m <sup>3</sup>
Price of natural gas	EUR 0.134/m <sup>3</sup>
Saved natural gas	69 m <sup>3</sup> /hour
Cost savings using solvent as the fuel	EUR 9.25/hour

**Table 4.46: Calculation of cost savings from the substitution of natural gas**  
The price of natural gas is based on statistics. The value chosen is that of the first three months of 2004, from users with a yearly turnover of 25000000 m<sup>3</sup>/year and an activity of at least 8000 hours/year

#### Driving force for implementation

Legislation, and return on investments.

#### References to literature and example plants

\*019A,I\*, \*037A,I\*, \*039F\* [34, Schwarting, 2001], [62, D1 comments, 2004]

## 4.3.5.8 Co-incineration of halogenated waste solvents

## Description

Co-incineration of halogenated waste solvents together with exhaust gases from production processes requires sufficient temperature, residence times and turbulence in the combustion chamber in order to ensure low emission levels of dioxins/furans. Hence, combustion temperatures of  $\geq 1100$  °C and residence times of  $\geq 2$  seconds are generally applied. Additionally, the emission levels are influenced by controlling the temperature profile (prevention of de novo formation) and by the subsequent flue-gas treatment. Table 4.47 shows the example from \*008A,I\*, where trials were carried out in order to demonstrate that the incinerator can also be operated at lower temperatures and residence times without a significant increase in emission levels. As a result, the incinerator is operated with a combustion temperature of  $\geq 850$  °C and a residence time of  $\geq 1$  second.

*008A,I*		
Flue-gas treatment	<ul style="list-style-type: none"> <li>• quench (30 m<sup>3</sup>/hour H<sub>2</sub>O)</li> <li>• scrubber (pH 7 – 8 and 30 m<sup>3</sup>/hour)</li> <li>• SCR (280 °C)</li> </ul>	
Waste solvent input	<ul style="list-style-type: none"> <li>• 500 kg/hour</li> <li>• mixture of isopropanol, methanol, methylene chloride</li> <li>• density of 0.81 – 0.85 kg/litre</li> <li>• H<sub>2</sub>O content 1 – 13 % w/w</li> <li>• Cl content 4.2 – 5.6 % w/w</li> </ul>	
Temperature control	±50 °C	
	<b>Trial 1</b>	<b>Trial 2</b>
Sampling time	3 x 6 hours	3 x 6 hours
Combustion temperature	$\geq 1200$ °C	$\geq 850$ °C
Residence time	$\geq 2$ seconds	$\geq 1$ second
Volume flow (dry)	6500 Nm <sup>3</sup> /hour	9600 Nm <sup>3</sup> /hour
Natural gas consumption	46 – 61 m <sup>3</sup> /hour	75 – 79 m <sup>3</sup> /hour
PCDD/F (I-TEQ) <sup>1</sup>	0.0019 ng/m <sup>3</sup>	0.0008 ng/m <sup>3</sup>
PCB (sum) <sup>1</sup>	0.006 µg/m <sup>3</sup>	0.007 µg/m <sup>3</sup>
PAH (sum) <sup>1</sup>	0.078 µg/m <sup>3</sup>	0.023 µg/m <sup>3</sup>
<sup>1</sup> the levels relate to Nm <sup>3</sup> , dry gas and 11 vol-% O <sub>2</sub>		
Result	Taking into account the accuracy of the analytical methods and the detection limits for each parameter, the resulting emission levels for PCDD/F, PCB and PAH do not differ significantly under the given trial conditions	

**Table 4.47: Example for the assessment of PCDD/F, PCB and PAH levels from an incinerator operated at different temperatures with different residence times**

**Achieved environmental benefits**

- lower support fuel consumption
- less maintenance, lower rate of wear.

**Cross-media effects**

No issues.

**Operational data**

See table Table 4.47.

**Applicability**

Assessment of each individual case is necessary.

**Economics**

Cost savings from lower support fuel consumption, lower maintenance and lower rate of wear.

**Driving force for implementation**

See Economics and Achieved environmental benefits.

**References to literature and example plants**

\*008A,I\*

## 4.3.5.9 Stripping and thermal oxidation of methanol

## Description

The recovery and purification of methanol from waste water streams (e.g. from alkylations) and its subsequent re-use is often not economically viable because of the formation of azeotropes with other organic contaminants. In most cases, the purchase of fresh methanol is simply much cheaper. However, highly methanol-loaded waste water streams may be well biodegradable but may also strain the capacity of existing WWTPs. Alternatively, methanol and other low molecular compounds can be stripped off with steam and can then be treated together with process exhaust gases by thermal oxidation. The calorific input from the stripper enables auto-thermal operation of the thermal oxidiser. Figure 4.49 gives an overview.

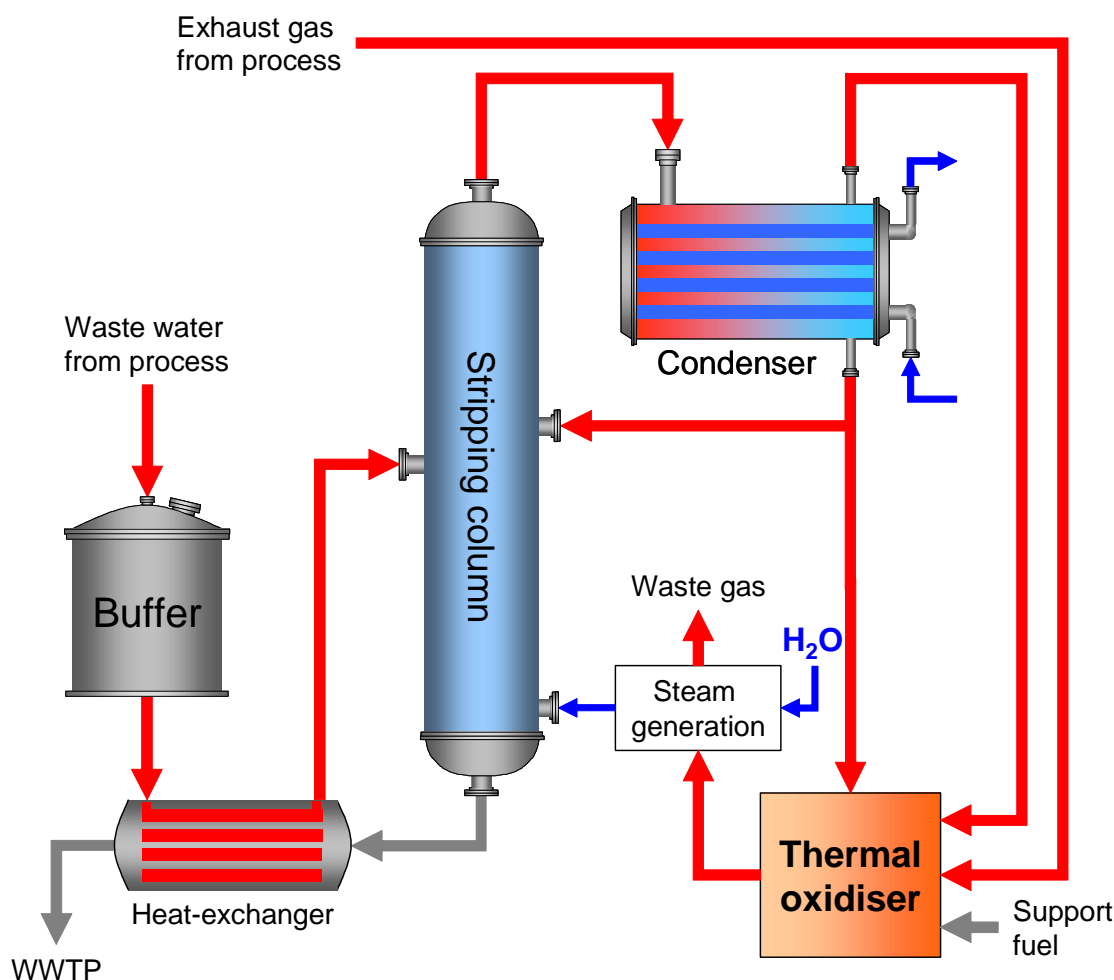

Figure 4.49: Stripping and thermal oxidation of methanol from waste water streams

## Achieved environmental benefits

- effective abatement for both waste water and waste gas
- high energy efficiency when in autothermal operation
- thermal oxidiser may also treat waste gas streams from other sources.

### Cross-media effects

- partial shift from waste water to waste gas
- support fuel necessary for start-up and shut down
- steam injection increases the waste water volume.

### Operational data

[15, Köppke, 2000]		
Waste water stream input to the stripper	Volume flow	20 m <sup>3</sup> /hour
	COD	About 20000 mg/litre
	BOD <sub>5</sub>	About 14000 mg/litre
Waste gas input from the process to thermal oxidiser		2000 m <sup>3</sup> /hour
Waste water to the WWTP	COD	3500 mg/litre
Steam consumption		3 tonnes/hour (75 % generated in the thermal oxidiser)

**Table 4.48: Operational data for stripping and thermal oxidation**

### Applicability

Generally applicable in cases with high organic loads which are strippable.

### Economics

[15, Köppke, 2000]		Costs per year (2000)	Conditions
<b>Operating costs</b>	Stripping and thermal oxidation	EUR 1760000 (DEM 3450000)	COD to stripper: 20000 mg/l
			COD to WWTP: 3500 mg/l
			Condensate: 10 – 30 % H <sub>2</sub> O
Operating costs include energy, staff and capital costs			

**Table 4.49: Operating costs for the combination of stripping and thermal oxidation**

- input COD loads <14500 mg/l alter the economic situation and favour a single treatment in a biological WWTP
- stripping to lower concentrations (COD <3500 mg/l) leads to increasingly higher costs
- H<sub>2</sub>O contents >30 % in the condensate alter the process to non-auto-thermal and require support fuel
- H<sub>2</sub>O contents <10 % are ineffective because of the high energy requirements.

### Driving force for implementation

Cost effective abatement technique, and ELVs.

### References to literature and example plants

[15, Köppke, 2000], \*020A,I\*

#### 4.3.5.10 Strategy for prevention and abatement of VOC emissions

##### Description

Existing installations can reduce their total VOC emissions to <5 % of the solvent input by following a combined strategy which involves:

- a) step-by-step implementation of integrated measures to prevent/reduce diffuse/fugitive emissions and to minimise the mass flow that requires abatement
- b) applying high level recovery/abatement techniques, such as thermal/catalytic oxidation or activated carbon adsorption
- c) applying specific recovery/abatement techniques at source on smaller sites with dedicated equipment, and by utilising only one or two different bulk solvents.

##### Achieved environmental benefits

Prevention and reduction of VOC emissions.

##### Cross-media effects

*None believed likely.*

##### Operational data

*No information provided.*

##### Applicability

Generally applicable.

##### Economics

Additional costs for equipment modification and of abatement techniques.

##### Driving force for implementation

A maintenance programme, and ELVs.

##### References to literature and example plants

\*017A,I\*, \*018A,I\*, \*019A,I\*, \*020A,I\*, \*023A,I\*, \*027A,I\*, \*028A,I\*, \*029A,I\*, \*030A,I\*, \*031A,I\*, \*032A,I\*

### 4.3.5.11 Recovery and abatement of acetylene

#### Description

Processes involving bulk amounts of highly volatile (and hazardous) compounds such as acetylene represent an extraordinary challenge concerning the treatment of waste streams. In the given example, acetylene is used as the reactant and is present in several exhaust gas streams together with ethylene (a by-product from the preparation of  $\text{Li}-\text{C}\equiv\text{C}-\text{H}$ ) and  $\text{NH}_3$  (one of the solvents).

Before process optimisation, the acetylene balance was as follows:

- consumption in the reaction 30 %
- loss as ethylene 20 %
- loss as acetylene 50 %.

After optimisation, most of the acetylene loss is recovered and recycled to the reaction according to the principle given in Figure 4.50. Liquid  $\text{NH}_3$  is used to absorb acetylene from exhaust gases and recycled after desorption back to the reaction cycle. The remaining  $\text{NH}_3$  is adsorbed in another stage in water and the remaining organic load (mainly ethylene) is used as the energy source for on-site steam generation. An  $\text{NH}_3/\text{H}_2\text{O}$  mixture (about 15 %  $\text{NH}_3$ ) is obtained and re-used in the process after rectification. The resulting water fraction is treated in the biological WWTP.

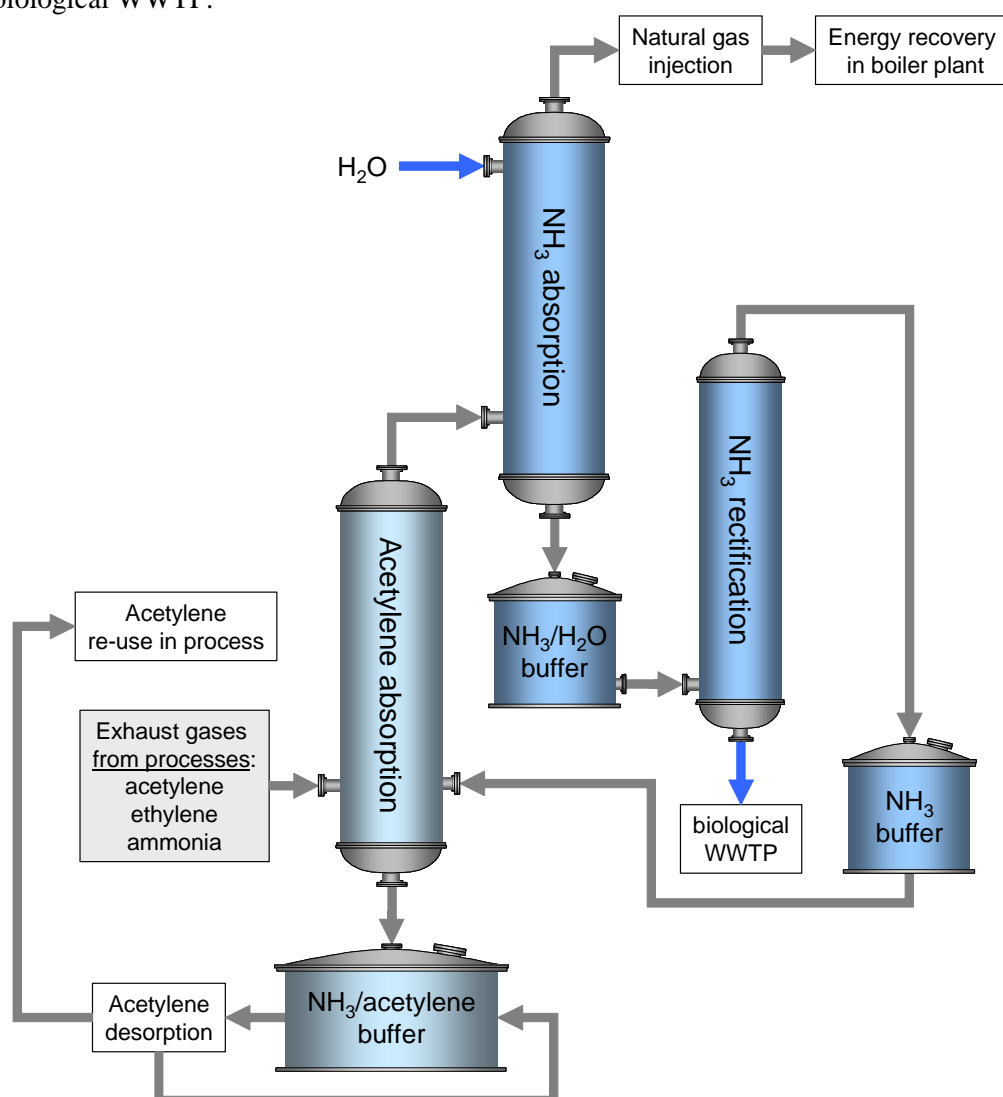

Figure 4.50: Acetylene recovery system

Since a wide part of the recovery system is operated below the boiling point of ammonia (-33 °C) a cooling system for very low temperatures is inevitable. The cooling medium used is identical to the reaction solvent (in this case, ammonia). Thus, not only can cooling be carried out without using chlorofluorohydrocarbons, but also any accidental mixing of the cooling ammonia with the ammonia of the process will not lead to problems, since it is identical with the solvent used. The pressure difference guarantees that, in case of a leak, the only possible flow will be of coolant into the reaction solution. Also, the strong smell of ammonia facilitates leak detection, so that amounts of coolant lost by leakage are very small.

The refrigeration process uses compressors and an expander system. The proximity of the refrigeration machinery enables the compressed hot ammonia to be used as a source of heat. Thus, the acetylene desorption column used to drive off dissolved acetylene is heated by waste heat from the refrigeration machines. Only the excess heat is removed by a cooling tower, and this requires a minimum amount of cooling water.

### Achieved environmental benefits

- less ammonia consumed (-75 %)
- less acetylene consumed (-50 %).

### Cross-media effects

- energy consumption for the recovery system
- waste water stream from NH<sub>3</sub> rectification.

### Operational data

*No information provided.*

### Applicability

Each case has to be assessed individually.

In the example, **the new process is more complex** than the original “straight-through” process. The effects are beneficial for both the ecology and the economy. The performance of new installations is optimised by ensuring that individual process steps harmonise with each other. This applies, not only within the identical batch plants used for the different stages, but also to energy utilisation in the boiler plant. Operators of these plants are required to have an increased level of understanding, and therefore, need improved training and education.

The idea of burning the high energy exhaust gases acetylene and ethylene in a process to produce steam is certainly attractive. However, **serious safety problems must be solved** before such a process can be considered. In this example, particular attention must be paid to the safety aspects of acetylene, which is explosive over a wide range of concentrations in air (lower flammability limit 2.3 vol-%, upper flammability limit 82 vol-%), and which can decompose at a moderately elevated pressure even in the absence of oxygen, generating large amounts of heat and high pressure. Investigations have shown that self-decomposition can be suppressed by diluting the acetylene with natural gas, even when the gas mixture is ignited. Since, in this example, the boiler plant runs on natural gas, this principle has been used for the combustion of the exhaust gas. Exhaust gases from the production plant are diluted to 40 % by injection of a stream of natural gas after they have passed through the absorber; they are then compressed to the pressure required by the boiler plant. Moreover, the production plant itself is separated from the combustion plant by a system of flame arrestors.



**Economics**

Economic benefits from recovery.

**Driving force for implementation**

Higher efficiencies, cost benefits, and environmental benefits.

**References to literature and example plants**

[9, Christ, 1999], \*014V,I\*

## 4.3.5.12 Catalytic oxidation of 1,2-dichloroethane

## Description

On the \*069B\* site, a batch/campaign process involves 1,2-dichloroethane as a reaction partner and a solvent. Exhaust gases arise from the reactor, the liquid-liquid phase separation and especially from a distillation stage, and contain 1,2-dichloroethane which is classified with risk phrase R45: may cause cancer.

Therefore, catalytic oxidation as a high level treatment technique was chosen in order to abate the 1,2-dichloroethane emission to a low level. Figure 4.51 illustrates the example from \*069B\*. The catalytic oxidiser is placed in a container on the roof of the production building and works autothermally after start-up. The catalytic oxidiser is included in the plant operating system and does not require additional staff.

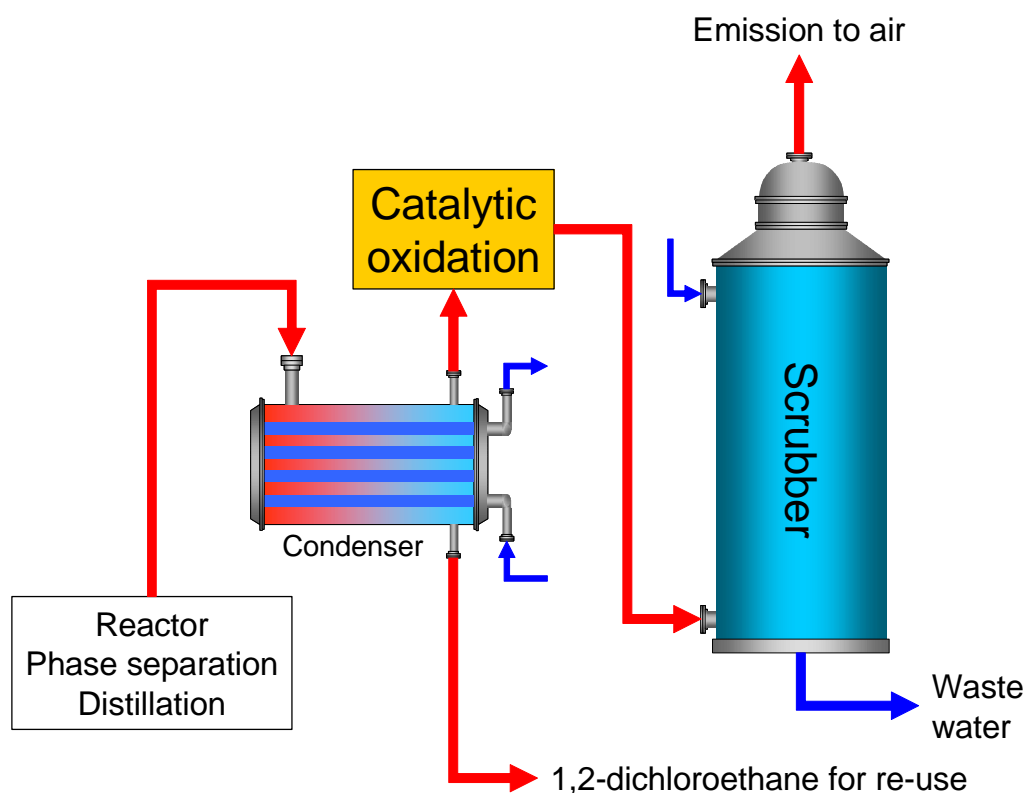

Figure 4.51: Catalytic oxidation of an exhaust gas containing 1,2-dichloroethane

## Achieved environmental benefits

Table 4.50 gives the achieved emission levels for the \*069B\* example.

Pollutant	Emission level	
	mg/m <sup>3</sup>	g/hour
1,2-dichloroethane	not confirmed!	

Table 4.50: Achieved emission level for 1,2-dichloroethane

## Cross-media effects

*None believed likely.*

**Operational data**

- volume flow: about 400 m<sup>3</sup>/hour
- autothermal operation after operation temperature is reached.

**Applicability**

Widely applicable. Other examples are:

- \*042A,I\*: Catalytic oxidation
- \*043A,I\*: Catalytic oxidation of vinyl chloride (R45: may cause cancer)
- \*043A,I\*: Catalytic oxidation of mercaptans
- \*055A,I\*: Catalytic oxidation (production building 1, autothermal)
- \*055A,I\*: Catalytic oxidation (production building 2, autothermal).

**Economics**

Overall investment costs (\*069B\*, 2004): EUR 1500000

**Driving force for implementation**

Hazardous pollutant.

**References to literature and example plants**

[91, Serr, 2004], \*069B\*, \*042A,I\*, \*043A,I\*, \*055A,I\*

## 4.3.5.13 Coupled concentration and catalytic oxidation of VOCs

## Description

High volume flows of exhaust air with low/variable VOC concentrations can be treated with a technique that concentrates the VOCs prior to catalytic oxidation (or condensation).

Figure 4.52 illustrates the technique: The exhaust gas is led through the adsorber (either a continuously rotating honeycomb structure or a series of packed beds), which can retain the VOCs in the temperature range of 10 to 120 °C. Around 80 to 95 % of the adsorbents are being charged at any one time. The remaining approx. 5 to 20 % of the adsorbents are being heated by hot air to desorb the previously adsorbed compounds, resulting in a gas stream with a high VOC concentration. The gas stream is then led through a catalyst, where the VOCs are oxidised (or alternatively the concentrated VOCs can be recovered by condensation). The air is heated when it passes through the catalyst (due to the oxidation of the VOCs); this heat can be recovered by heat-exchange and used in the heating of the gas stream.

In many applications, the catalyst can be integrated into the adsorber (catalytic coating) so that adsorbed VOCs are oxidised as soon as they are desorbed.

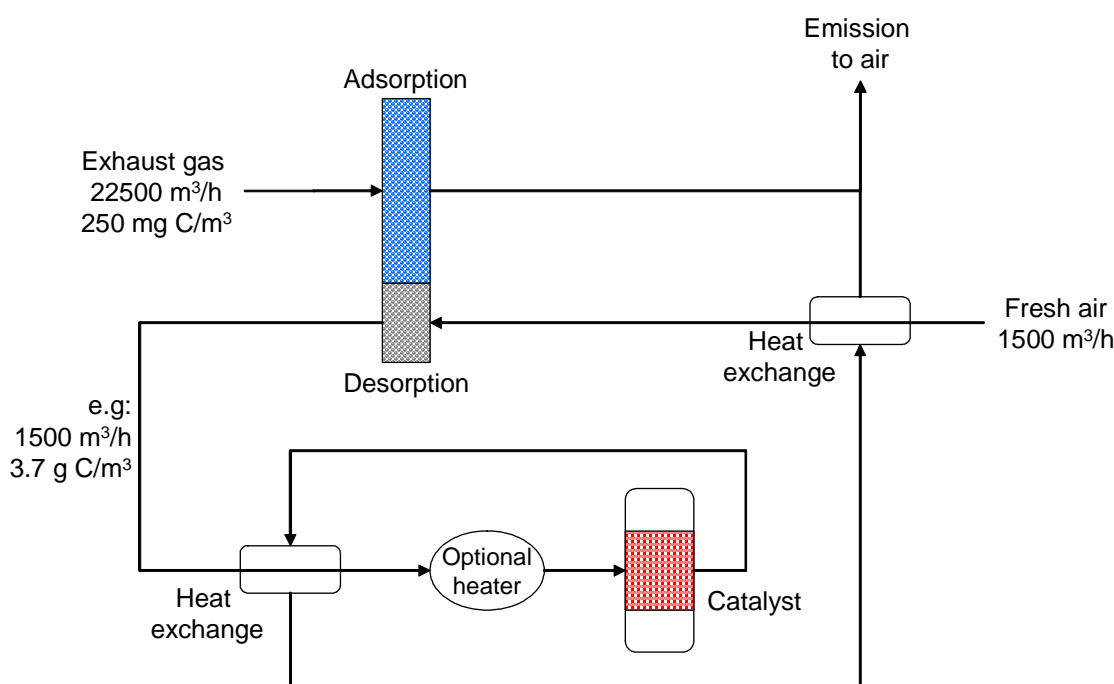

Figure 4.52: Coupled concentration and catalytic oxidation of VOCs

## Achieved environmental benefits

- removal of VOCs from exhaust gas streams
- low energy consumption (5 to 30 times lower than the consumption related to thermal oxidation, recuperative thermal oxidation or catalytic oxidation). Often continuous operation is possible without support fuel
- no need for pre- or stand-by heating at night time/weekends
- low pressure loss, hence less energy for ventilation required.

## Cross-media effects

*None believed likely.*

**Operational data**

- VOC concentrations from 10 to 1000 mg/m<sup>3</sup>
- exhaust gas temperatures of up to 120 °C are acceptable
- adsorbent non-flammable and thermally stable up to 500 °C
- low pressure loss
- low space requirements for the equipment.

**Applicability**

Applicable to exhaust gas flows with changing/variable VOC concentrations, since batch wise concentration peaks are automatically levelled out by the adsorber. Suitable for a wide range of solvents, e.g. toluene, xylene, MIBK, MEK, styrene, and glycol, in concentrations from 10 to approx. 1000 mg/m<sup>3</sup>. The adsorber functions up to the exhaust gas temperature of around 120 °C.

**Economics**

- low operating costs due to low heating requirements
- intensified use of abatement equipment, hence optimised (smaller) layout.

**Driving forces for implementation**

See Economics.

**References to literature and example plants**

[95, Up-To-Date Umwelttechnik AG, 2005, 96, Up-To-Date Umwelttechnik AG, 2005],  
\*104X\*, \*105X\*

## 4.3.5.14 Non-thermal exhaust gas treatments

	Condensation	Cryogenic condensation	Wet-scrubbing	Adsorption	Biofiltration
Description	Elimination of solvent vapours (VOCs) from gas streams by reducing temperature below the dew point	Elimination of solvent vapours (VOCs) from gas streams by reducing temperature below the dew point	Mass transfer (absorption) between a soluble gas and a solvent in contact with each other	Mass transfer between a adsorbable gas and a solid surface	Degradation in a filter bed by micro-organisms
Achieved environmental benefits	<ul style="list-style-type: none"> <li>material recovery possible</li> <li>reduction of mass flow to downstream abatement</li> </ul>	<ul style="list-style-type: none"> <li>material recovery possible</li> <li>performance up to 99 % VOC reduction (depending on the individual case)</li> </ul>	<ul style="list-style-type: none"> <li>material recovery possible, depending on pollutants</li> <li>performance up to 99 % reduction for inorganic compounds and highly water soluble VOCs (e.g. alcohols)</li> <li>the achievable value for HCl is <math>&lt;1 \text{ mg/m}^3</math>, and <math>2 - 5 \text{ mg/m}^3</math> for phosphorus chlorides [62, D1 comments, 2004]</li> </ul>	<ul style="list-style-type: none"> <li>performance depends on the adsorption characteristic of the individual compound, up to 95 % reduction for VOCs</li> </ul>	<ul style="list-style-type: none"> <li>performance depends on the biodegradability of the particular VOC</li> </ul>
Operational data	<u>Condensation temperatures:</u> <ul style="list-style-type: none"> <li>down to <math>2 \text{ }^\circ\text{C}</math> with ice</li> <li>down to <math>-60 \text{ }^\circ\text{C}</math> with different brine types</li> </ul>	<u>Condensation temperatures:</u> <ul style="list-style-type: none"> <li>down to <math>-120 \text{ }^\circ\text{C}</math> with cryogenic types (liquid nitrogen)</li> </ul>	<u>Usual scrubber media:</u> <ul style="list-style-type: none"> <li>water</li> <li>acid</li> <li>alkaline</li> <li>polyethylene glycol ethers (PEG) for non-polar VOCs</li> </ul>	Usually two bed setup with interchange and regeneration of the off-line bed with steam, monitoring for breakthrough	
Cross-media effects	<ul style="list-style-type: none"> <li>energy demand</li> </ul>	<ul style="list-style-type: none"> <li>high energy demand</li> <li>obtained solvents have to be recovered/disposed of</li> </ul>	<ul style="list-style-type: none"> <li>shift of pollutant loadings to the waste water pathway with aqueous scrubbing media</li> </ul>	<ul style="list-style-type: none"> <li>shift of pollutant loadings to the waste water pathway if regeneration is carried out with steam, additional treatment/disposal may be necessary</li> <li>down-cycled activated carbon has to be disposed of</li> </ul>	

	Condensation	Cryogenic condensation	Wet-scrubbing	Adsorption	Biofiltration
Applicability	Ice or brine type condensers are standard equipment directly attached to VOC sources, normally with feedback to the source.  Additional downstream treatment may be required	<ul style="list-style-type: none"> <li>- restricted to low flowrates (&lt;1000 m<sup>3</sup>/hour)</li> <li>- restrictions associated with water in the gas stream</li> </ul>	<ul style="list-style-type: none"> <li>+ widely applicable for inorganic compounds</li> <li>- restricted applicability for polar VOCs</li> <li>- not applicable for non-polar or halogenated VOCs</li> <li>+ PEG is applied for non-polar VOCs</li> </ul>	<ul style="list-style-type: none"> <li>+ proven technology with dry single component air streams</li> <li>- restricted applicability with multipurpose operation (moisture, higher molecular weight compounds)</li> </ul>	<ul style="list-style-type: none"> <li>• odour control</li> <li>• control of readily degradable organic streams</li> </ul>
Economics	<ul style="list-style-type: none"> <li>• low capital costs</li> <li>• low operating costs</li> </ul>				
Driving force	<ul style="list-style-type: none"> <li>• material recovery</li> <li>• relief of downstream abatement</li> </ul>	<ul style="list-style-type: none"> <li>• material recovery, final treatment of exhaust gas streams</li> </ul>	<ul style="list-style-type: none"> <li>• final treatment of exhaust gas streams, material recovery</li> </ul>	<ul style="list-style-type: none"> <li>• final treatment of exhaust gas streams, material recovery</li> </ul>	<ul style="list-style-type: none"> <li>• final treatment of exhaust gas streams</li> </ul>
References	[31, European Commission, 2003, 36, Moretti, 2002], [63, Short, 2004], *020A,I*				

### 4.3.5.15 Induction of non-thermal plasma and catalytic oxidation of VOCs

#### Description

The technique consists of two stages: First the pollutant molecules are excited by a strong electrical alternating field of several thousand volts inside an excitation chamber. The excited state of the gas molecules theoretically corresponds to a heating of several thousand degrees Celsius, without an actual, significant change in the gas temperature (so-called non-thermal plasma). At the second stage, the gas is led through a contact catalyst, where the excited molecules are completely oxidised. Both stages are operated at room temperature or at the actual temperature of the exhaust gas.

#### Achieved environmental benefits

- removal of VOCs from exhaust gas streams
- high energy efficiency, since no heat energy has to be added/removed
- efficient odour removal.

#### Cross-media effects

*None believed likely.*

#### Operational data

- volumetric flows from 20 m<sup>3</sup>/hour up to several hundred thousand m<sup>3</sup> per hour
- operated at room temperature or at the actual temperature of the exhaust gas
- energy consumption for excitation purposes 0.5 – 3 watt hours per m<sup>3</sup> of treated exhaust gas; precise energy consumption depends on the pollutant and the concentration.

#### Applicability

The main applications are for the elimination of odour and smoke, cleaning of supply air, sterilisation and elimination of solvent loads efficiently up to about 100 mg/m<sup>3</sup>. This technique is not sensitive to variations in concentration or changes in the composition of the exhaust gas.

Example from \*015D,I,O,B\*: elimination of odour from the ventilation of a biological WWTP.

#### Economics

- economic especially for small to average concentrations
- low expenditure on maintenance
- low operating costs due to low energy consumption.

#### Driving forces for implementation

See Economics.

#### References to literature and example plants

\*015D,I,O,B\*, [97, Up-To-Date Umwelttechnik AG, 2005], [98, Up-To-Date Umwelttechnik AG, 2005]



### 4.3.5.16 Minimising emission concentration peaks

#### Description

A characteristic aspect of batch processes is the variation of pollutant load and volume flow in exhaust gases. Such variations represent a challenge for the operation of recovery or abatement techniques and result frequently in undesirable emission concentrations peaks. Peak concentrations potentially have a higher environmental impact.

Such effects can be minimised by the application of adsorption smoothing filters as shown in Figure 4.53.

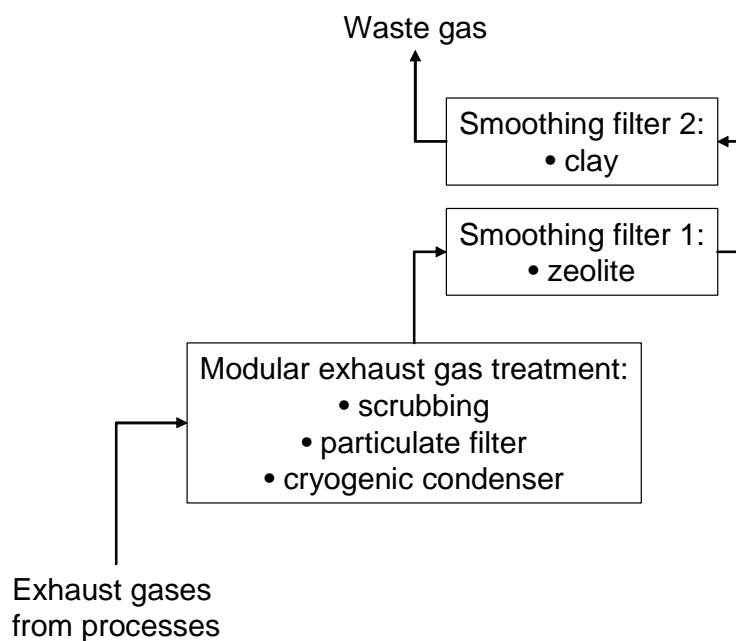

Figure 4.53: Smoothing of emission concentration peaks

#### Achieved environmental benefits

Minimisation of emission concentration peaks.

#### Cross-media effects

*None believed likely.*

#### Operational data

Example from \*055A,I\*:

- 1200 kg Zeocat PZ-2400
- 960 kg clay Alumina A
- temperature range -30 to 200 °C.

#### Applicability

Generally applicable to optimise the ratio between average and peak concentrations.

### Economics

*No information provided.*

### Driving force for implementation

- minimisation of environmental impact from peak emission concentrations
- compliance with concentration limits, safety considerations [99, D2 comments, 2005].

### References to literature and example plants

[91, Serr, 2004], \*055A,I\*

#### 4.3.5.17 Management of a modular exhaust gas treatment setup

##### Description

In individual cases, the application of one main abatement system on a multipurpose site leads to unsatisfactory situations. Examples are: low performance of a scrubber system in the case of non-polar VOCs, or low energy efficiency of a thermal oxidiser in the case of high support fuel consumption. The main cause is that the exhaust gas streams on a multipurpose site occur neither continuously nor regularly and also vary in terms of pollutants, volume flow, concentration, and loading.

A modular exhaust gas treatment setup can reflect the operational mode of a multipurpose plant much better and a management system can ensure a high level of co-ordination between production and operation of the abatement systems. This includes a continuous optimisation of the system and the basic parameters. The basic recovery/abatement toolbox includes:

- scrubbing with water or, where appropriate, other media (e.g. NaOH, H<sub>2</sub>SO<sub>4</sub>, NaHSO<sub>3</sub>)
- condensers at appropriate temperatures
- activated carbon adsorption with an appropriate layout.

This optimisation also includes the equalisation of the input to recovery/abatement techniques by avoiding the accumulation of flow or load peaks which enables a more intensified use of the available recovery/abatement capacity.

The main components are to:

- (1) identify and analyse the emission causing operations and their chronological sequence
- (2) take measures to reduce volume flows and loadings at source
- (3) consider the remaining volume flows from relevant operations
- (4) consider the physico-chemical properties of the pollutants (e.g. saturation concentrations, adsorption characteristics)
- (5) set an operational “emission limit level” (see Table 4.51)
- (6) select one or a combination of suitable abatement modules including the operational options
- (7) optimise this procedure for the possible production situations.

Some basic rules are applied to the selection of the abatement modules:

- inorganic compounds are treated by scrubbing
- the treatment of polar organic compounds includes scrubbing
- at least one condenser stage is applied to all volume flows <50 m<sup>3</sup>/hour
- activated carbon adsorption is the add-on, if the VOC emission mass flows would exceed the values given in Table 4.51.

The continuous optimisation of the system requires regular monitoring.

##### Achieved environmental benefits

The modular setup provides a day by day individual recovery/abatement solution for the individual production situation. In many cases, it is possible to avoid costs and energy consumption for establishing thermal oxidation on site.

Additionally, the modular setup creates motivation to implement all possible process-integrated measures to reduce volume flows and loadings at source.

- intensified use of abatement capacity, provoking process-integrated measures
- avoidance of inefficient standalone abatement solutions.

The emission levels used for management and selection of recovery/abatement techniques correspond with 100 % of the operational “emission limit level” and are given in Table 4.51. Experience shows that:

- the mean emission level is approximately 40 % of the operational “emission limit level”
- maximum emission peaks occur up to 200 % of the operational “emission limit level”.

Parameter		Operational mass flow	
total organic C	kg/hour	<0.25	
Methanol		<0.25	
Ethanol		<0.25	
2-propanol		<0.25	
Acetic acid		<0.25	
Ethylacetate		<0.25	
Toluene		<0.25	
1,1,1-trichloroethane		<0.25	
1,1-dichloroethane		<0.25	
Tetrachloroethylene		<0.050	
Methylenechloride		<0.050	
NO <sub>x</sub> as NO <sub>2</sub>		<0.5	
SO <sub>x</sub> as SO <sub>2</sub>		<0.1	
HCl		<0.01	
NH <sub>3</sub>		<0.01	
Particulates	<0.1	g/hour	
Cl <sub>2</sub>	<5		
H <sub>2</sub> S	<1		
HBr	<1		
HCN	<1		
Benzene	<1.25		Carcinogenic
1,2-dichloroethane	<1.25		
Trichloroethene	<1.25		
Bromoethane	<1.25		
Acrylnitrile	<0.75		
Ethylenoxide	<0.75		
Benzo(a)pyrene	<0.075		
Ni and its compounds	<0.75		
As and its compounds (without AsH <sub>3</sub> )	<0.075		
Cd and its compounds	<0.075		
AsH <sub>3</sub>	<1.25	Particulates	
Cyanides (easily soluble)	<2.5		
Cu – compounds	<2.5		
Pb – compounds	<1.25		
Ni – compounds	<1.25		
Hg – compounds	<0.125		
Tl – compounds	<0.125		

Table 4.51: Achievable emission values for a modular abatement setup

**Cross-media effects**

- cross-media effects of the individual abatement techniques
- higher emissions due to the setting of an operational “emission limit level”.

**Operational data**

The mass flows given in Table 4.51 also represent the key parameters for considering sources and the selection of the abatement modules.

**Applicability**

The modular abatement setup is applicable for multipurpose/multiproduct sites where VOC loadings and volume flows are not high enough to enable efficient thermal/catalytic oxidation.

Difficulties arise if peak emissions of highly volatile compounds (e.g. butane, ethylene) have to be handled for short time periods.

**Economics**

Besides the costs of the individual abatement techniques, additionally the costs for implementation and maintenance of the management system have to be taken into account.

Costs for the prevention of errors, e.g. automation equipment [99, D2 comments, 2005].

**Driving force for implementation**

Emission limit values, and avoidance of thermal/catalytic oxidation.

**References to literature and example plants**

[54, Verfahrens u. Umwelttechnik Kirchner, 2004] \*059B,I\*

### 4.3.5.18 Selection of a VOC treatment and emission levels

#### Description

The selection of a VOC treatment technique is a crucial task on a multipurpose site. Besides the process condensers the usual “toolbox” for the main recovery/abatement of VOCs from exhaust gases are:

- scrubbing (usually water)
- cryogenic condensation
- activated carbon adsorption
- catalytic oxidation
- thermal oxidation/incineration.

The step to the more sophisticated treatment technique is triggered either by increasing the plant size (indicating also the need for higher flexibility on a more complex plant) or the actual achievable emission level. Options to avoid this step are a reduction in volume flow or an increased capacity, e.g. for scrubbing or activated carbon adsorption, and/or lower condensation temperatures. Table 4.52 shows examples for scrubbers which were later replaced by thermal oxidisers.

	Concentration	Volume flow	Mass flow
	mg C/m <sup>3</sup>	m <sup>3</sup> /hour	kg C/hour
Scrubber a	38 – 53	5000	0.2 – 0.3
Scrubber b	37 – 177	5300	0.2 – 1
Scrubber c	100	10000	1
Scrubber d	124 – 228	5400	0.7 – 1.2

**Table 4.52: Examples for the VOC emission levels from scrubbers which were later replaced by thermal oxidation**

The use of a more sophisticated treatment technique is also necessary if the exhaust gas contains highly volatile or toxic material, e.g. acetylene (see Section 4.3.5.11) or 1,2-dichloroethane (see Section 4.3.5.12).

Figure 4.54 and Figure 4.55 show concentration and mass flow values for total organic C emitted from point sources (data are taken from Table 3.1 and Table 3.2). On a multipurpose site low total organic C concentrations in waste gas emissions do not automatically represent low emissions (see also Table 4.53). Emission levels are understandable only in terms of kg/hour ( $\equiv$  concentration x volume flow), since the actual volume flows vary considerably, e.g.

- scrubbers: 50 – 38000 m<sup>3</sup>/hour
- thermal oxidiser/incinerators: 400 – 45000 m<sup>3</sup>/hour

This indicates that “dilution” occurs where additional volumes are treated, e.g.

- where building ventilation is connected to a main scrubber
- where exhaust gases are mixed with air in order to enable combustion in an oxidiser (oxygen demand) or especially to minimise explosion risks (keep it below the LEL).

	Concentration	Volume flow	Mass flow
	mg C/m <sup>3</sup>	m <sup>3</sup> /hour	kg C/hour
Scrubber 1	279	57	0.016
Scrubber 2	9	38000	0.34
TO 1	0.8	20000	0.016
TO 2	35	8600	0.3

**Table 4.53: Examples for VOC concentrations and mass flows from point sources**

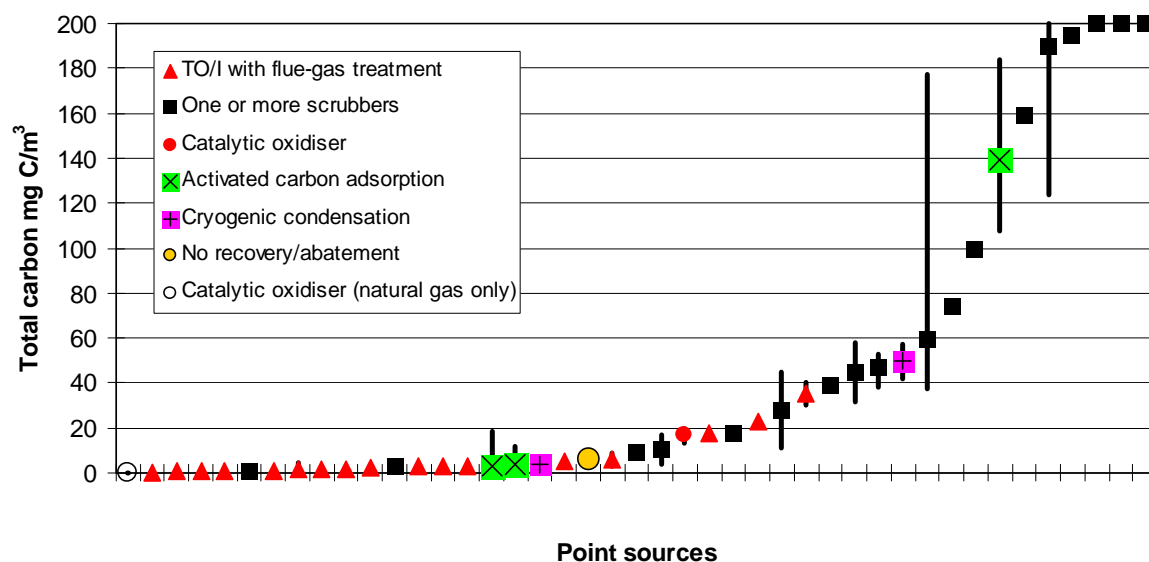

Figure 4.54: Concentration values VOC emissions from OFC point sources

The expression “point source” relates to one reported set of emission data. It is possible, that several data sets belong to the same plant or even the same emission point within the plant, but reflect different operational conditions. TO/I means thermal oxidiser or incinerator. Concentration values higher than 200 mg/m<sup>3</sup> are simply shown as 200 mg/m<sup>3</sup>; vertical bars are the maximum and minimum values. The presented data are taken from Table 3.1

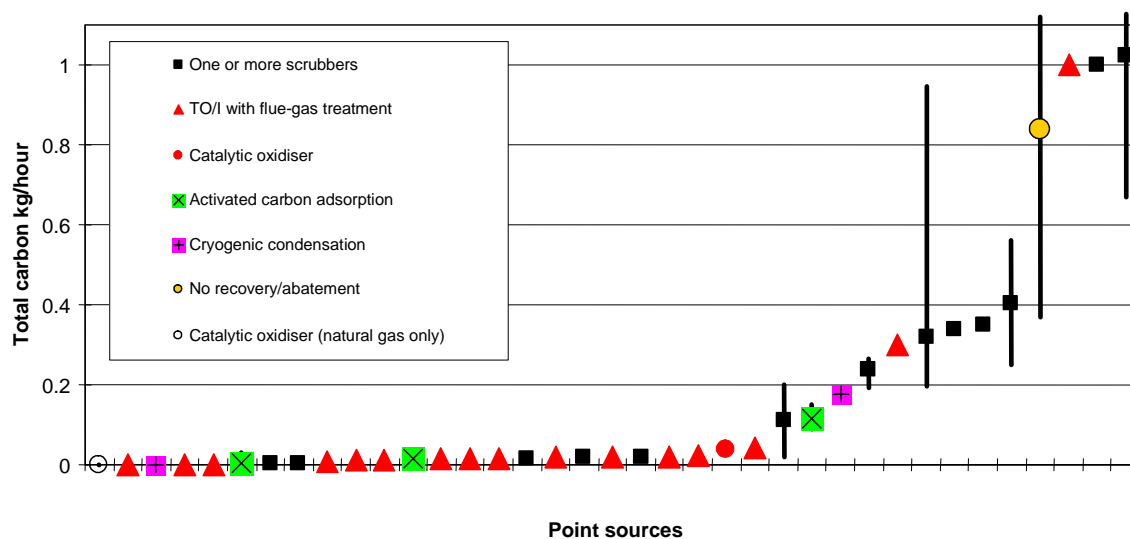

Figure 4.55: Mass flow values of VOC emissions from OFC point sources

The expression “point source” relates to one reported set of emission data. It is possible, that several data sets belong to the same plant or even the same emission point within the plant, but reflect different operational conditions. TO/I means thermal oxidiser or incinerator. Vertical bars are the maximum and minimum values. The presented data are taken from Table 3.2.

#### Achieved environmental benefits

- overview to selection of techniques and emission levels.

## Cross-media effects

Cross-media effects of the applied recovery/abatement techniques:

- scrubbing creates waste water streams
- activated carbon adsorption requires desorption of the carbon by creation of a waste water stream or disposal of the loaded carbon
- cryogenic condensation requires energy for cooling
- catalytic or thermal oxidation requires support fuel.

Therefore, the step to a more sophisticated treatment technique will usually increase the cross-media effects. Minor cross-media effects occur for catalytic/thermal oxidation where:

- support fuel can be replaced by spent solvents
- autothermal operation is possible
- or energy can be recovered for steam generation.

## Operational data

Operational data of the individual treatment techniques.

## Applicability

Generally applicable.

## Economics

The techniques presented as the usual “toolbox” are widely applied across the OFC sectors. The step to a more sophisticated (and more costly) technique is usually accompanied by increased plant size. Table 4.54 gives cost estimations per removed tonne of VOC [60, SICOS, 2003]. The costs for cryogenic condensation are much lower if the N<sub>2</sub> is used to feed the inert gas network [99, D2 comments, 2005].

Costs		EUR per removed tonne of VOC
Investment	Production equipment	38000
	Gas collection system	1400 – 12000
	Thermal oxidation and treatment of acid gases	6000
	Cryogenic condensation	1600 – 29000
	Thermal oxidation and co-incineration of liquid waste	500
Operation	Thermal oxidation and treatment of acid gases	600
	Cryogenic condensation	300 – 1600
	Thermal oxidation and co-incineration of liquid waste	100
	Measurements	400
Yearly total	Production equipment	5500
	Gas collection system	200 – 1800
	Thermal oxidation and treatment of acid gases	1500
	Cryogenic condensation	600 – 5800
	Thermal oxidation and co-incineration of liquid waste	200

**Table 4.54: Cost estimation per removed tonne of VOC**  
[60, SICOS, 2003]



**Driving force for implementation**

Selection of recovery/abatement technique is crucial on an OFC site.

**References to literature and example plants**

See reference plants in Table 3.1 and Table 3.2, [60, SICOS, 2003]

4.3.5.19 NO<sub>x</sub>: recovery, abatement and emission levels

## Description

Sources for exhaust gases containing NO<sub>x</sub> on OFC sites are mainly:

- chemical processes, e.g. nitrations
- thermal oxidation/incineration of exhaust gases (thermal oxidation of organic compounds containing nitrogen, e.g. acetonitrile or N<sub>2</sub> from air).

On sites where nitrations are carried out extensively (e.g. manufacture of explosives), the recovery of spent acids represents a strong NO<sub>x</sub> source. Many exhaust gases containing NO<sub>x</sub> from chemical processes contain also VOCs and can be treated in a thermal oxidiser/incinerator equipped with a DeNO<sub>x</sub> system (where already available on site). Another option is the design of the oxidiser as a two stage combustion [99, D2 comments, 2005].

The often used concentration unit ppm (ml/m<sup>3</sup>) can be converted to the mass concentration (mg/m<sup>3</sup>) with the following factor: 1 ppm = 1.88 mg/m<sup>3</sup> (based on monomeric NO<sub>2</sub> at 101.3 kPa and 298 Kelvin and ideal gas behaviour). As a rule, the discharge of NO<sub>x</sub> is colourless if the concentration is <200 ppm (370 mg/m<sup>3</sup>) [6, Ullmann, 2001].

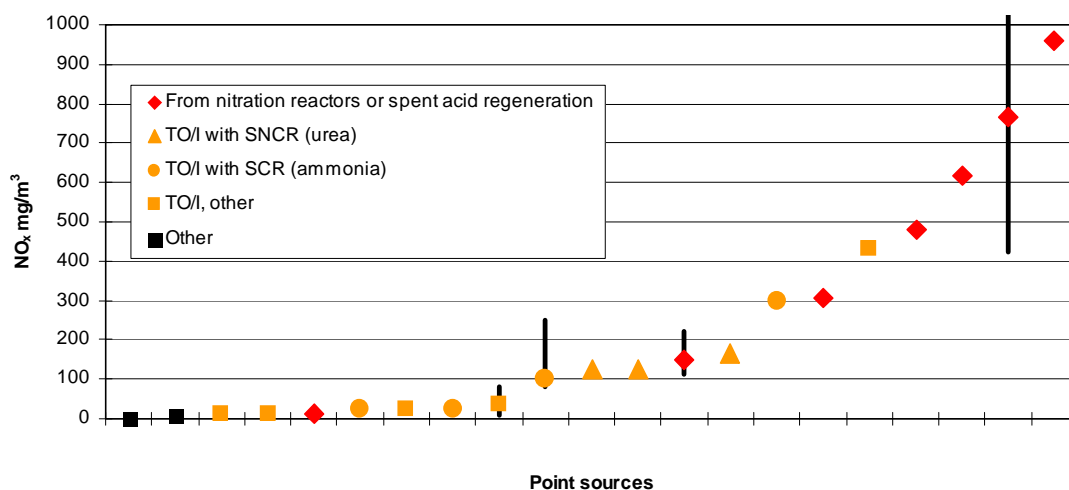

Figure 4.56: Concentration values for NO<sub>x</sub> emissions from point sources

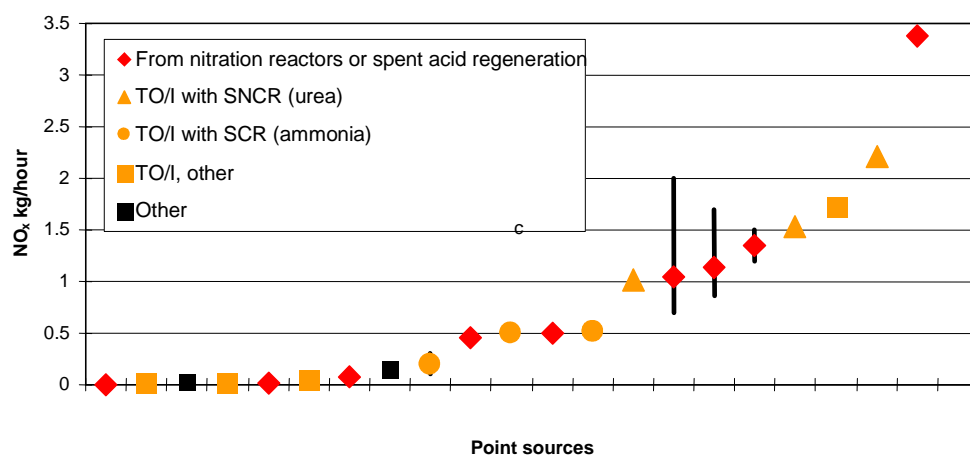

Figure 4.57: Mass flow values for NO<sub>x</sub> emissions from point sources

The expression “point source” relates to one reported set of emission data. It is possible, that several data sets belong to the same plant or even the same emission point within the plant, but reflect different operational conditions. TO/I means thermal oxidiser or incinerator. Vertical bars are the maximum and minimum values

a) NO<sub>x</sub> from thermal oxidation/incineration

NO<sub>x</sub> levels in flue-gases from thermal oxidation depend mainly on the combustion temperature as well as on the input of compounds containing nitrogen. For example, in the case of \*019A,I\* NO<sub>x</sub> levels of about 650 mg/m<sup>3</sup> are created at a temperature of 1150 °C and then reduced by SCR with an efficiency of about 96 %.

	Concentration <sup>1</sup>	Mass flow <sup>1</sup>	Volume flow <sup>1</sup>	Temperature	DeNO <sub>x</sub>
	mg/m <sup>3</sup>	kg/hour	m <sup>3</sup> /hour		
010A,B,D,I,X	38	0.018	473	830 °C	
059B,I	13	0.045	3460		
019A,I (1)	25 (CO: 17)	0.5	20000	1150 °C	SCR (NH <sub>3</sub> )
019A,I (2)	26	0.52	20000	1150 °C	SCR (NH <sub>3</sub> )
107I,X	100	0.1 – 0.3	1200		SCR (NH <sub>3</sub> )
037A,I	126	1.01	8015	1100 °C	SNCR (urea)
020A,I	124 (CO: 2.5)	1.53	12338	1150 °C	SNCR (urea)
106A,I (2)	430	1.72	4000	980 °C	no
001A,I (2)	164	2.21	13475		SNCR (urea)
114A,I	300	13.4	45000	900 – 1000 °C	no

<sup>1</sup> The levels are expressed as NO<sub>2</sub> and relate to dry gas, Nm<sup>3</sup> and 11 vol-% O<sub>2</sub>

**Table 4.55: NO<sub>x</sub> emissions from thermal oxidisers/incinerators**

Where higher combustion temperatures are used, or where exhaust gases contain nitrogenous compounds, SCR or SNCR are applied in order to reduce the NO<sub>x</sub> emission level, using NH<sub>3</sub> or urea as a reduction equivalent. NH<sub>3</sub> or urea is dosed in on demand as opposed to being a continuous feed. One NO<sub>x</sub> analyser is located before the DeNO<sub>x</sub> unit and measures the raw value while the other analyser is located after the outlet. The PLC compares the two values and doses the urea accordingly. Figure 4.58 shows the effect of different urea dosing in the case of \*020A,I\* by changing the NO<sub>x</sub> setpoint from 50 to 150 mg/m<sup>3</sup>. Table 4.56 shows the related urea consumption.

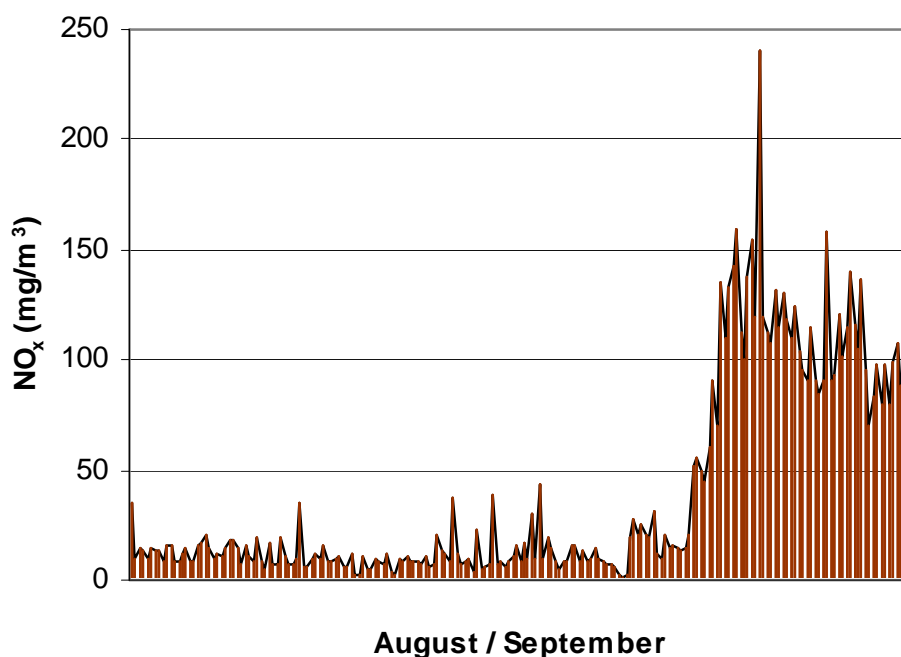

**Figure 4.58: Effect of changed NO<sub>x</sub> setpoint for the SNCR in the case of \*020A,I\***

	Urea dosing	NO <sub>x</sub> setpoint	
2000	20 t	50 mg/m <sup>3</sup>	
2001	17.9 t	150 mg/m <sup>3</sup>	
2002	17 t		
2003	18 t		Acetonitrile usage on site increased
Price for urea: about EUR 170/tonne (2003)			

**Table 4.56: Urea consumption of a SNCR according to NO<sub>x</sub> setpoint**

b) NO<sub>x</sub> from chemical processes: nitrations and recovery of spent acids

Among the reported NO<sub>x</sub> emissions the highest values are reported from production sites where nitration of alcohols (e.g. nitrocellulose, NC or nitroglycol, NG) and recovery of spent sulphuric/nitric acids is carried out. Table 4.57 gives the provided data from the manufacture of NC and recovery of spent acids. Especially high NO<sub>x</sub> levels occur in cases where the use of concentrated HNO<sub>3</sub> causes oxidation of organic compounds as a side reaction [99, D2 comments, 2005].

	NO <sub>x</sub> emission level <sup>1</sup>		Volume flow m <sup>3</sup> /h	Recovery system	Dominant production	Acid recovery
	kg/hour	mg/m <sup>3</sup>				
062E	0.069	480	145	None	NG	
026E	1.2 – 1.5	up to 4000			NC	
044E	3.38	615	5500	6 x H <sub>2</sub> O	NC	
063E	0.7 – 2.0	425 – 1098	1650 – 1820	4 x H <sub>2</sub> O	NC	
098E	0.87 – 1.69	113 – 220	7700	3 x H <sub>2</sub> O 1 x H <sub>2</sub> O <sub>2</sub>	NC	2300 kg/h

<sup>1</sup> The levels are expressed as NO<sub>2</sub> and relate to dry gas and Nm<sup>3</sup>

**Table 4.57: NO<sub>x</sub> emission data from nitration and recovery of spent acids**

Recovery of HNO<sub>3</sub> is carried out by absorption cascades. The absorption efficiency depends on the absorption pressure, the number of stages, and the temperature. The temperature of the gas between stages is especially important because it governs the progress of oxidation, which is the limiting parameter for the entire absorption process [6, Ullmann, 2001]. Hence, the highest efficiency is achieved by application of scrubbing with H<sub>2</sub>O<sub>2</sub> in the last absorption stage (see also Section 4.3.5.1).

#### Achieved environmental benefits

Lower NO<sub>x</sub> emissions, and efficient recovery.

#### Cross-media effects

Water consumption, energy and chemicals consumption.

#### Operational data

*No information provided.*

#### Applicability

Generally applicable.

**Economics**

*No information provided.*

**Driving force for implementation**

Lower emission levels and efficient recovery

**References to literature and example plants**

See reference plants in Table 4.57.

4.3.5.20 Scrubbing of NH<sub>3</sub> from exhaust gases and related emission levels

## Description

Figure 4.59 and Figure 4.60 show NH<sub>3</sub> emission values (concentrations and mass flows) from point sources (vertical bars represent maximum and minimum values). The presented data are taken from Table 3.1 and Table 3.2. The obtained data show the following characteristics:

- emission via one or more scrubbers with different scrubbing media (e.g. H<sub>2</sub>O, acid)
- all emission concentrations for NH<sub>3</sub> are <10 mg/m<sup>3</sup>
- all emission mass flows for NH<sub>3</sub> are <0.11 kg/h.

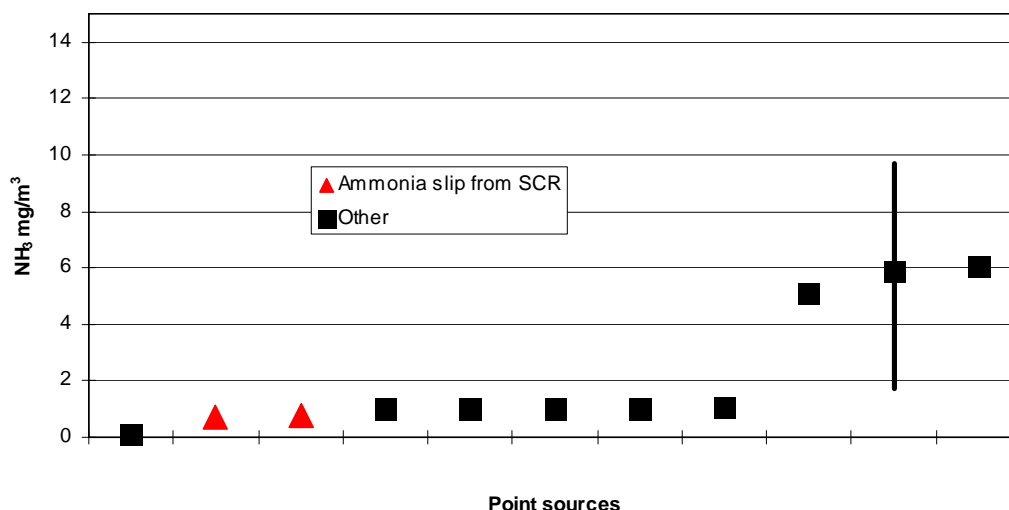

Figure 4.59: Concentration values for NH<sub>3</sub> emissions from point sources

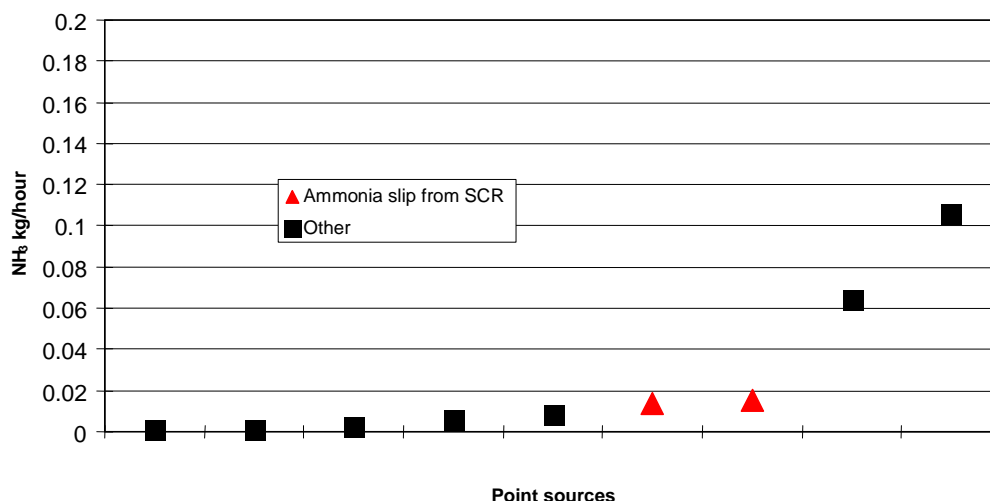

Figure 4.60: Mass flow values for NH<sub>3</sub> emissions from point sources

The expression “point source” relates to one reported set of emission data. It is possible, that several data sets belong to the same plant or even the same emission point within the plant, but reflect different operational conditions; vertical bars are the maximum and minimum values

## Achieved environmental benefits

Removal of NH<sub>3</sub> from exhaust gases, and lower emission levels.

**Cross-media effects**

Water and chemical consumption.

**Operational data**

*No information provided.*

**Applicability**

Generally applicable. Scrubbers are standard equipment.

**Economics**

*No information provided.*

**Driving force for implementation**

NH<sub>3</sub> emission levels.

**References to literature and example plants**

All reference plants apply scrubbing.

4.3.5.21 Scrubbing of SO<sub>x</sub> from exhaust gases and related emission levels

## Description

Figure 4.61 and Figure 4.62 show SO<sub>x</sub> emission levels (concentrations and mass flows) from point sources. The presented data are taken from Table 3.1 and Table 3.2. The obtained data show the following characteristics:

- emission via one or more scrubbers with different scrubbing media (e.g. H<sub>2</sub>O, NaOH)
- only concentration values <15 mg/m<sup>3</sup> are reported
- only mass flows below 0.4 kg/hour are reported
- high mass flows belong to high concentration levels
- the outlier of 82 mg/m<sup>3</sup> \*001A,I(1)\* was left out of the diagram as the source was changed.

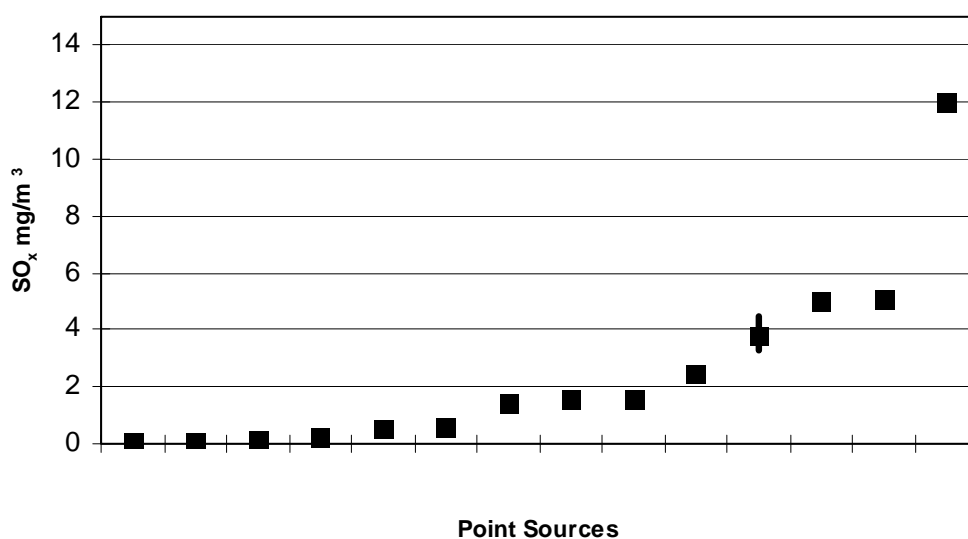

Figure 4.61: Concentration values for SO<sub>x</sub> emissions from point sources

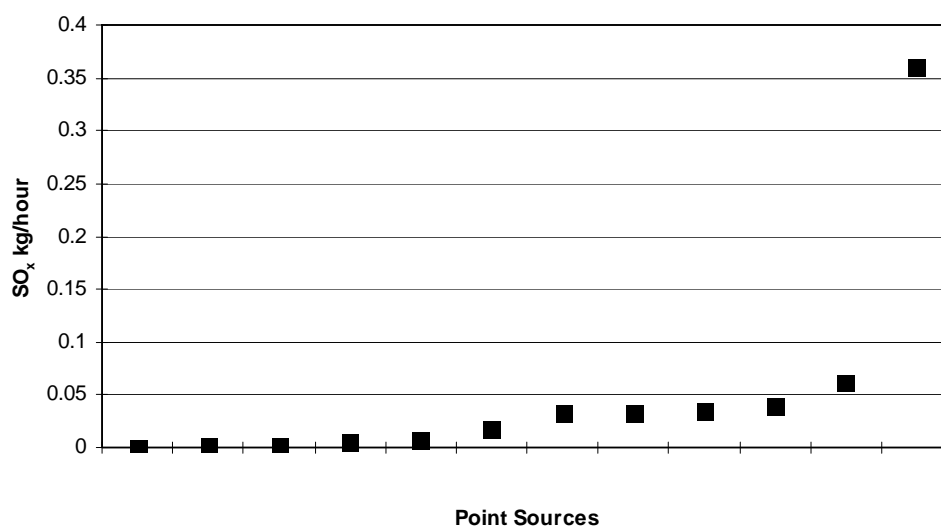

Figure 4.62: Mass flow values for SO<sub>x</sub> emissions from point sources

The expression “point source” relates to one reported set of emission data. It is possible, that several data sets belong to the same plant or even the same emission point within the plant, but reflect different operational conditions; vertical bars are the maximum and minimum values



**Achieved environmental benefits**

Removal of SO<sub>x</sub> from exhaust gases, and lower emission levels.

**Cross-media effects**

Water and chemical consumption.

**Operational data**

*No information provided.*

**Applicability**

Generally applicable. Scrubbers are standard equipment.

**Economics**

*No information provided.*

**Driving force for implementation**

SO<sub>x</sub> emission levels.

**References to literature and example plants**

All reference plants apply scrubbing.

## 4.3.5.22 Particulate removal from exhaust gases

Figure 4.63 and Figure 4.64 show particulate emission levels (concentrations and mass flows) from point sources. The presented data are taken from Table 3.1 and Table 3.2. The obtained data show the following characteristics:

- recovery/abatement by application of tube filters, bag filters, fabric filters, cyclones and/or within the main abatement systems such as thermal oxidation with optional Wet Electrostatic Precipitator (WESP) or scrubbing
- where particulates are emitted from a thermal oxidiser/incinerator it is presumed that the particulates consist of mineralised substances
- reported concentrations range from 0.05 to 5 mg/m<sup>3</sup>. The outlier of 13 mg/m<sup>3</sup> is emitted from a thermal oxidiser without WESP
- reported mass flows range from <0.001 to 0.2 kg/hour
- the highest mass flow (0.2 kg/hour) belongs to the lowest concentration value (0.05 mg/m<sup>3</sup>).

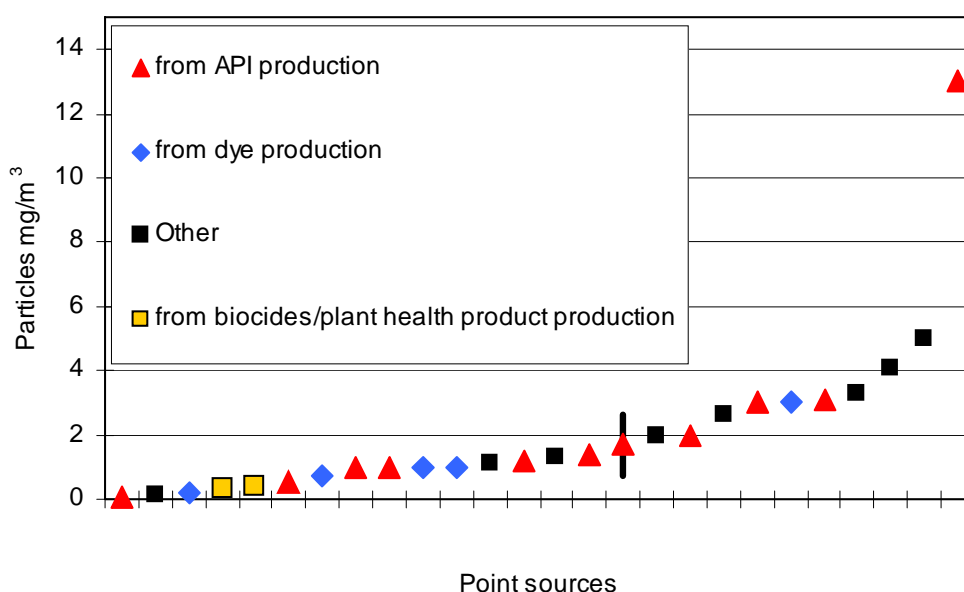

Figure 4.63: Concentration values for particulate emissions from point sources

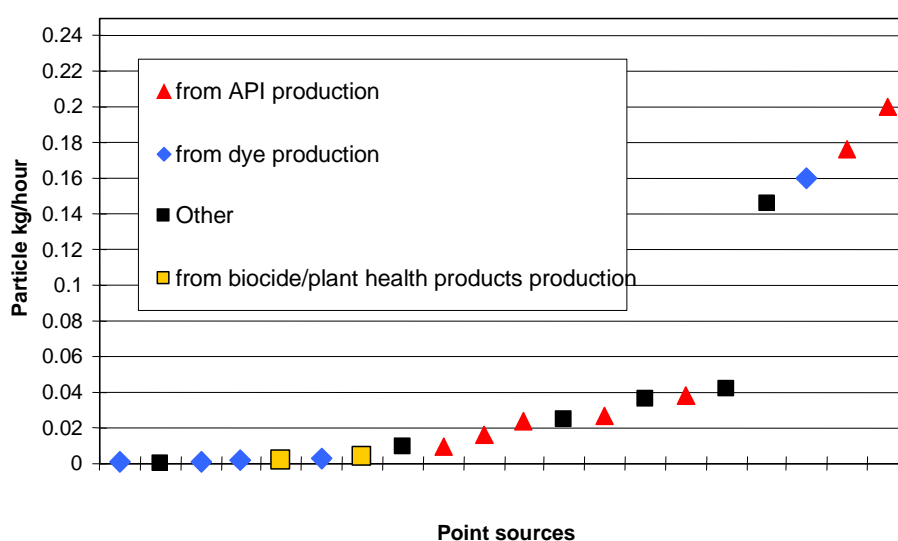

Figure 4.64: Mass flow values for particulate emissions from point sources

The expression “point source” relates to one reported set of emission data. It is possible, that several data sets belong to the same plant or even the same emission point within the plant, but reflect different operational conditions; vertical bars are the maximum and minimum values

### 4.3.6 Destruction of free cyanides

#### 4.3.6.1 Destruction of free cyanides with NaOCl

##### Description

Due to toxic effects, cyanides are removed from rich and lean exhaust gas/waste water streams using scrubbing, pH adjustment and oxidative destruction as shown in Figure 4.65 for unit 1 on the \*023A,I\* site. The setup for unit 2 omits a second scrubber and a buffer tank. In a final step,  $\text{CNO}^-$  is transformed with soda into  $\text{CO}_2$  and  $\text{N}_2$ .

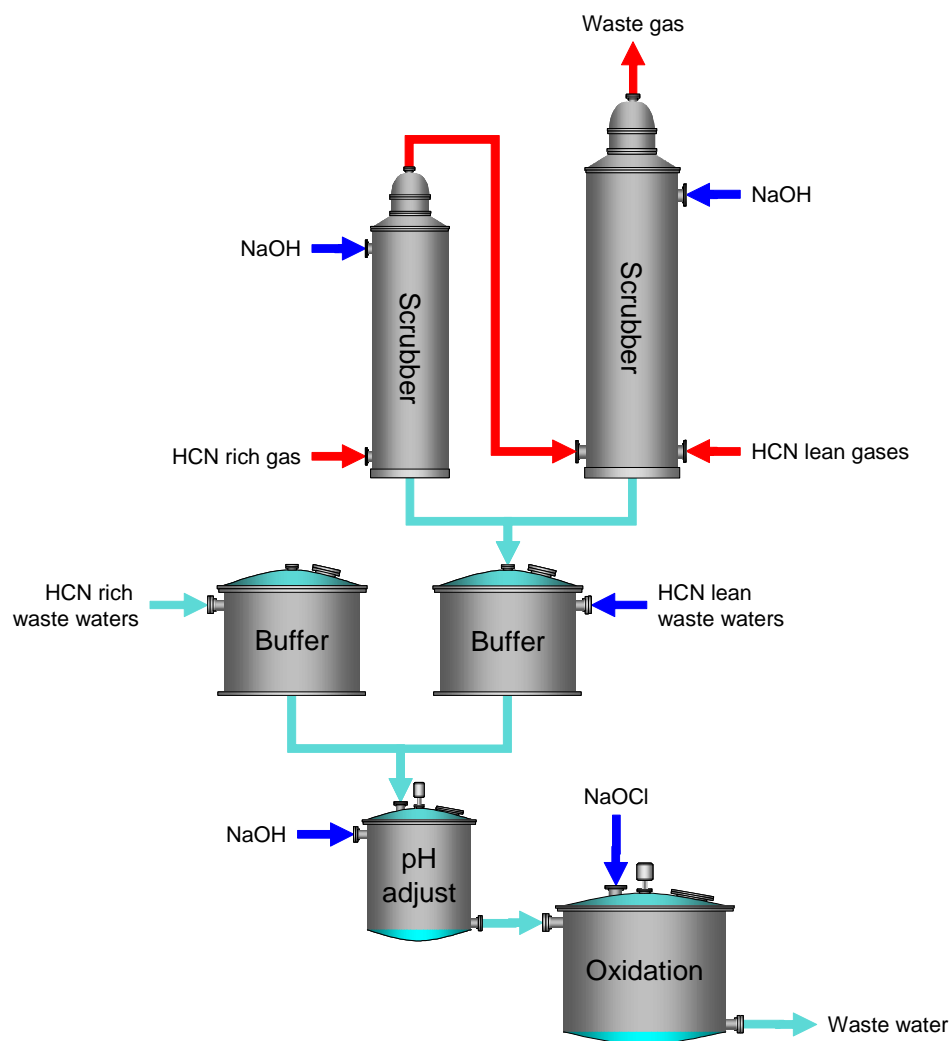

Figure 4.65: Destruction of cyanides

##### Achieved environmental benefits

- removal of  $\text{HCN}/\text{CN}^-$  from exhaust gases and waste water streams
- achieved emission values (Table 4.58):

		Concentration	Mass flow	Reference
Unit 1	Exhaust gas	0.9 mg/m <sup>3</sup>	3.2 g/hour	*023A,I*
	waste water streams	Below detection limit		
Unit 2	Exhaust gas	1.0 mg/m <sup>3</sup>	2.0 g/hour	
	waste water streams	Below detection limit		

Table 4.58: Achieved emission values after destruction of cyanides

**Cross-media effects**

- consumption of treatment chemicals
- energy consumption
- increased salt loads in waste waters
- potential for formation of AOX.

**Operational data**

		<b>Unit 1</b>	<b>Unit 2</b>	
				Reference
<b>Treatment capacity</b>	HCN rich gas	50 m <sup>3</sup> /hour 16 kg/hour HCN 320 g/m <sup>3</sup> HCN	2000 m <sup>3</sup> /hour 40 kg/hour HCN 20 g/m <sup>3</sup> HCN	*023A,I*
	HCN lean gas	3500 m <sup>3</sup> traces of HCN		
	Oxidation	85 kg NaCN/batch	30 kg NaCN/batch	
<b>Overall efficiencies</b>	99.99 %			

**Table 4.59: Operational data for the destruction of cyanides****Applicability**

Generally applicable. Where cyanides occur in waste water streams with high COD loads, principally the oxidative pretreatment options for the elimination of organic loadings are also applicable for cyanide destruction (e.g. wet oxidation with O<sub>2</sub>, see also Section 4.3.7.4).

Other organic compounds may interfere, e.g. alcohols [62, D1 comments, 2004].

Alternatively, organic cyanides can be destroyed with HCHO [62, D1 comments, 2004].

A similar setup is used for phosgene removal with the following achieved level for emission to air (\*024A,I\*):

- <0.04 mg/m<sup>3</sup> at a mass flow of <0.5 g/hour.

**Economics**

*No information provided.*

**Driving force for implementation**

Removal of toxic compounds from waste gases and waste waters

**References to literature and example plants**

\*023A,I\*, \*024A,I\*

### 4.3.6.2 Destruction of free cyanides with $\text{H}_2\text{O}_2$

#### Description

Due to toxic effects, cyanides are removed from an air stream using a scrubber with NaOH solution. The solution is circulated between a buffer vessel and the washer. The solution is sampled regularly and exchanged if the content of free  $\text{OH}^-$  is too low for the absorption of HCN from the air stream.

The cyanide solution is then reconditioned with other  $\text{CN}^-$  rich waste water streams to substitute raw materials. A  $\text{CN}^-$  low waste water stream leaves the reconditioning. The remaining cyanide is destroyed together with  $\text{CN}^-$  low waste water streams using pH adjustment and oxidative destruction with  $\text{H}_2\text{O}_2$ .

#### Achieved environmental benefits

- removal of HCN/ $\text{CN}^-$  from exhaust gases
- achieved emission values: see Table 4.60
- re-use of waste water streams
- no AOX formation
- no contaminated solid residues.

#### Cross-media effects

- energy and chemical consumption
- safety aspects from  $\text{H}_2\text{O}_2$  use.

#### Operational data

For treatment capacity and efficiency see Table 4.61.

#### Applicability

Generally applicable.

Where cyanides occur in waste water streams with high COD loads, principally the oxidative pretreatment options for the elimination of organic loadings are also applicable for cyanide destruction (e.g. wet oxidation with  $\text{O}_2$ , see also Section 4.3.7.4).

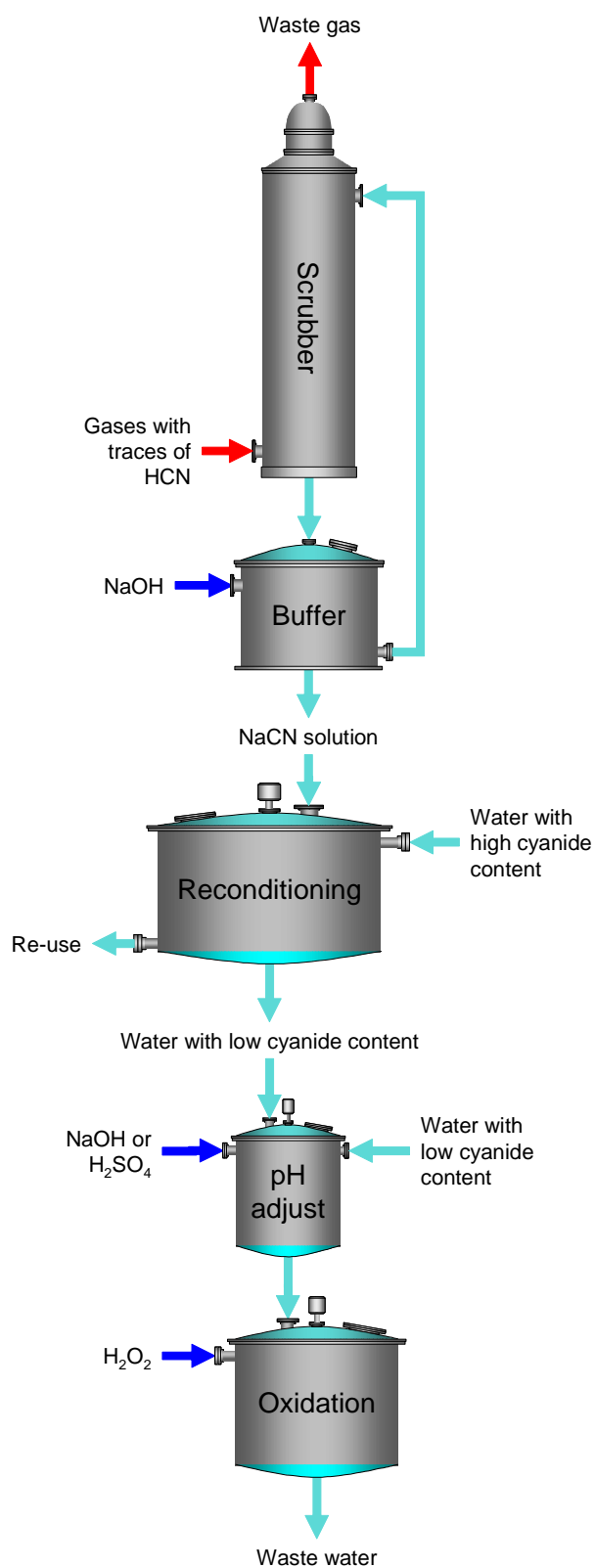

Figure 4.66: Destruction of cyanides with  $\text{H}_2\text{O}_2$

Alternative examples:

On the \*097I\* site, waste water streams containing cyanides up to 50000 mg/l are treated by hydrolysis (e.g. heating to 180 °C) to achieve levels <1 mg/l. Waste water streams with a lower cyanide content (up to 5000 mg/l) are treated with H<sub>2</sub>O<sub>2</sub> to achieve levels <0.03 mg/l.

On the \*036L\* site, process effluents containing cyanides are treated with alkali (pH = 11) and reaction with formaldehyde. The resulting cyanhydrine is fed to an adapted biological WWTP and is degradable. If monitoring shows free CN >30 mg/l, the pretreatment is repeated.

	Concentration	Mass flow	Reference
Exhaust gas	1 mg/m <sup>3</sup>	3 g/hour	[62, D1 comments, 2004]
Waste water streams	1.1 mg/l	2.3 g/hour	

**Table 4.60: Achieved emission values after the destruction of cyanides**

			Reference
<b>Treatment capacity</b>	Gas stream	3400 m <sup>3</sup> /hour 50 mg/m <sup>3</sup> HCN	[62, D1 comments, 2004]
	waste water with high CN concentration	1 m <sup>3</sup> /hour 5 % CN <sup>-</sup>	
	waste water with low cyanide content	15 m <sup>3</sup> /hour 700 mg/m <sup>3</sup> HCN	
<b>Overall efficiency</b>	99.9 %		

**Table 4.61: Operational data for the destruction of cyanides with H<sub>2</sub>O<sub>2</sub>**

### Economics

Cost reduction for waste water treatment.

### Driving force for implementation

Removal of toxic compounds from exhaust gases and waste water streams

### References to literature and example plants

[62, D1 comments, 2004]

### 4.3.7 Management and treatment of waste water streams

#### 4.3.7.1 Pretreatment of waste water streams by separation

	Distillation	Stripping	Adsorption	Extraction	Membrane processes
Description	Removal of a low boiling portion from the waste water stream by fractionated distillation	Removal of a volatile compound from the waste water stream with an inert stripping gas followed by condensation or incineration	Removal of components from the waste water stream by adsorption to activated carbon. Desorption of the loaded activated carbon with hot steam or by burning	Removal of components with an extraction solvent that is insoluble in water. The difference in density leads to phase separation, followed by: <ol style="list-style-type: none"> <li>(1) incineration of the extraction solvent containing the removed component</li> <li>(2) evaporation of the solvent and incineration of the residue</li> <li>(3) biological treatment of the water phase</li> </ol>	The target component is retained by semi-permeable membrane (reverse osmosis or nanofiltration)
Achieved environmental benefits	Removal of volatile organic compounds and high or refractory AOX or COD loads before biological treatment, material recovery possible	Particularly removal of volatile chlorinated compounds before biological treatment of the waste water stream, material recovery possible	Effective removal of phenols, halogenated compounds (AOX) before biological treatment. Removal efficiency [15, Köppke, 2000]: phenols: >92 % AOX: >91 %	Removal of high or refractory AOX or COD loads before biological treatment	Increasing of concentration or desalting of waste water streams with high or refractory COD or AOX loads before further treatment (usually incineration)
Operational data	Depends on the separation task	Depends on the separation task	Desorption of the loaded activated carbon on- or off-site	Examples of solvents are light crude oil, toluene, pentane, hexane	Depends on the separation task
Cross-media effects	High energy consumption if overhead distillation of larger amounts of water is necessary to reach target concentrations	Cross-media effects depend on the treatment of the stripping gas (e.g. condensation, incineration)	Disposal options have to be considered for loaded activated carbon or desorbed material	Depending on the treatment of the extraction solvent (e.g. incineration or evaporation/incineration)	Depending on the treatment of a resulting concentrated waste water stream

	Distillation	Stripping	Adsorption	Extraction	Membrane processes
Applicability	Suitable for volatile compounds, not suitable if larger amounts of water have to be distilled overhead	Restricted to volatile compounds	Other contaminants are adsorbed as well, and thus reduce effectiveness, therefore also used as polishing step after biological treatment	Not suitable with low contaminant concentrations	Suitable for increasing the concentration and desalting Low selectivity for AOX
Economics	<b>Example: up-concentration before incineration (1995)</b> organic load: 25 wt-% flowrate: 15 tonnes/d  elimination of 5 % load and of 78 vol-% by distillation to lead to reduction of overall costs by 10 %	<b>Example: intermediate for a herbicide (1995)</b> flowrate: 4 m <sup>3</sup> /h concentration: 70 mg AOX/l reduction to <1 mg AOX/l		Costs depend on the price for the solvent and a possible use of the caloric value  <b>Extraction of chloro-aromatics with i-decanol:</b> Flowrate: 20 m <sup>3</sup> /h; AOX: 150 – 1500 mg/l Costs including evaporation, incineration of residues and biological treatment: EUR 5.75 (DEM 11.24)/m <sup>3</sup> (2000)	Lower energy costs compared to thermal methods
		EUR 120 (DEM 230)/kg AOX including the following catalytic oxidation	EUR 750 (DEM 1400)/kg AOX		
Driving force	Relief of the biological treatment stage from COD/AOX loads with low biodegradability or inhibiting/toxic effects				
References	Too many references to list them	*047B*, *082A,I*, *020A,I*	*009A,B,D*,	*069B*, *047B*	
	[33, DECHEMA, 1995]; [31, European Commission, 2003]; [15, Köppke, 2000] and references within				



## 4.3.7.2 Pretreatment of waste water streams by oxidation

	Waste water incineration	Chemical oxidation	Wet oxidation in acidic medium	Low pressure wet oxidation	Wet oxidation in alkali medium
Description	Total oxidation of the organic load by incineration together with a support fuel. Auto-thermal conditions are possible above 50 – 100 g/l COD	Total or partial oxidation of organic contaminants with ozone or H <sub>2</sub> O <sub>2</sub> supported by UV light or catalysts (e.g. Fenton's agent)	Oxidation of organic contaminants with air, usually followed by biological treatment	Partial oxidation of organic contaminants with air or pure O <sub>2</sub> and catalyst, usually followed by biological treatment	Oxidation of organic contaminants with O <sub>2</sub> or air, usually followed by biological treatment
Achieved environmental benefits	Total removal of low-degradable or toxic organic load	Removal of low-degradable or toxic organic load or enhancement of biodegradability	Removal of low-degradable or toxic organic load	Enhance biodegradability of organic load: COD elimination 80 % AOX elimination 90 %	Removal of low-degradable or toxic organic load
Operational data	1200 °C if halogenated compounds are burned	For an example, see Section 4.3.8.2	<ul style="list-style-type: none"> <li>temperature: 175 – 325 °C</li> <li>pressure: 20 – 200 bar</li> <li>acidic medium</li> </ul>	Bubble column: Temperature: 120 – 220 °C Pressure: 3 – 25 bar catalyst: Fe salts, chinones	Temperature: 250 – 320 °C Pressure: 100 – 150 bar Alkali medium
Cross-media effects	<ul style="list-style-type: none"> <li>energy consumption if not auto-thermal</li> <li>possible requirement for flue-gas treatment</li> </ul>	<ul style="list-style-type: none"> <li>consumption of chemicals</li> <li>loss of Fe to waste water</li> <li>energy consumption</li> </ul>	<ul style="list-style-type: none"> <li>energy consumption</li> <li>potential to form dioxins</li> </ul>	<ul style="list-style-type: none"> <li>energy consumption</li> <li>potential to form dioxins</li> </ul>	<ul style="list-style-type: none"> <li>energy consumption</li> </ul>
Applicability	Suitable (auto-thermal) with CODs above 50 – 100 g/l, alternatively preceded by a step to increase the concentration or carried out with support fuel		High salt contents may require a desalting step (membrane or extraction), corrosion can be a problem	<u>Input:</u> Chloride content up to 5 % COD >10000 mg/l	No corrosion problems occur up to a salt content of 8.5 % w/w

	Waste water incineration	Chemical oxidation	Wet oxidation in acidic medium	Low pressure wet oxidation	Wet oxidation in alkali medium
Economics	<p><b>Typical costs:</b> EUR 530 (DEM 1000)/t waste water (1995)</p>	<p><b>Example for total oxidation (1995):</b> COD/AOX ratio: 20:1 H<sub>2</sub>O<sub>2</sub> consumption: 2.125 kg/kg COD 42.5 kg/kg AOX at EUR 1.1 (DEM 2)/kg H<sub>2</sub>O<sub>2</sub> (100 %)</p> <p>For additional cost estimates, see Section 4.3.8.2</p>	<p>Special materials of construction, e.g. titanium can result in high costs [62, D1 comments, 2004]</p> <p><b>Typical costs:</b> EUR 530 (DEM 1000)/t waste water (1995) (without desalting)</p>	<p>In comparison with wet oxidation lower costs due to simpler material requirements</p>	<p>EUR 0.6 – 0.7/kg COD, including depreciation</p>
	<p><b>Comparison of combinations (1995)</b> 40 tonnes waste water/day</p>				
	<p>Distillation + incineration EUR 67 (DEM 125)/m<sup>3</sup></p>	<p>Partial oxidation + biological treatment EUR 41 (DEM 76)/m<sup>3</sup></p>			
Driving force	<p>Relief of the biological treatment stage from particular COD/AOX loads with low biodegradability or inhibiting/toxic effects</p>				
References	<p>*001A,I*, *019A,I*, *023A,I*, *047B*, *079D*, *080I*, *033L*, *036L*, *081A,I*, *042A,I*, *043A,I*, *091D,I*, *092B,I*</p>	<p>*004D,O*, *068B,D,I*, *108B,I*, *109A,V*, *110B*, *111A,I*, 112L, see also Section 4.3.8.2</p>	<p>*015D,I,O,B*</p>	<p>*014V,I*, *033L*, *034A,I*, *035D*, *042A,I*, *046I,X*, *050D*</p>	<p>*078L*, *087I*, *088I,X*</p>
	<p>[90, 3V Green Eagle, 2004]; [92, Collivignarelli, 1999]; [33, DECHEMA, 1995]; [39, Bayer Technology Services, 2003]; [31, European Commission, 2003]; [15, Köpke, 2000], and references within</p>				

## 4.3.7.3 Pretreatment options for waste water streams on an OFC plant

## Description

\*010A,B,D,I,X\* established various pretreatment options to deal with different types of waste water streams. Figure 4.67 gives an overview. The standard options include biological treatment, activated carbon adsorption and waste water incineration. Additional steps are applied if the waste stream contains cyanides (treatment with  $H_2O_2$ ) or heavy metals (precipitation/filtration). Typical examples for the assignment of waste water streams are given in Table 4.62 (the decisive parameter/cause is highlighted).

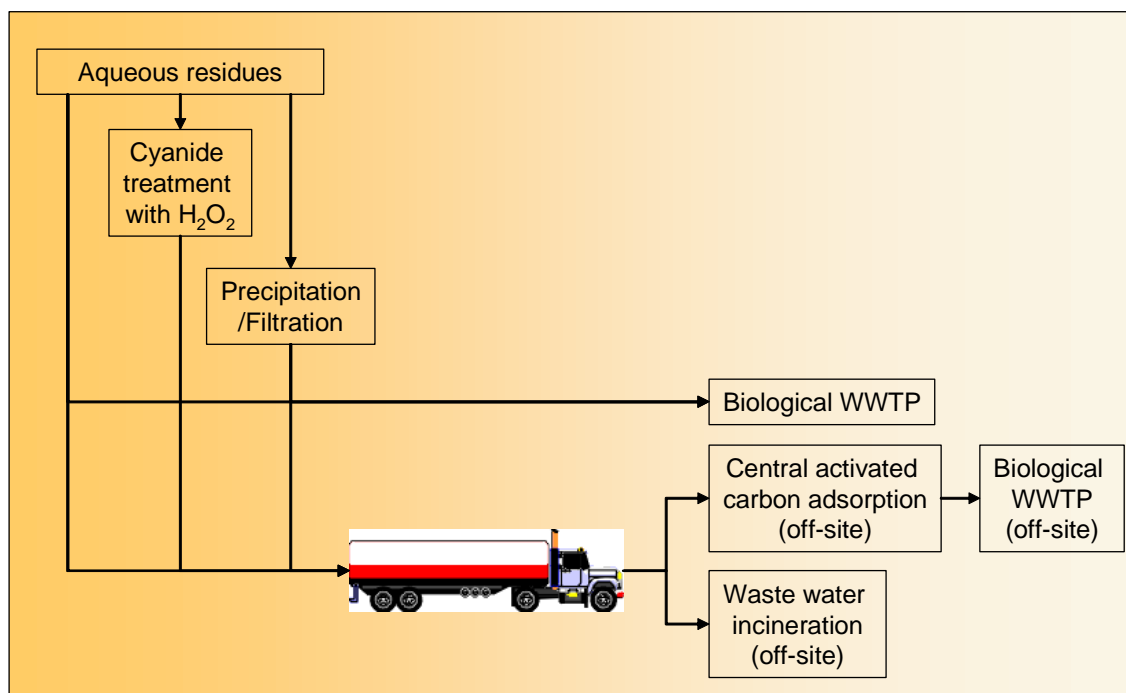

Figure 4.67: Pretreatment/treatment options established by \*010A,B,D,I,X\*

(Pre)treatment options		Unit	Before (pre)treatment	After (pre)treatment	Pretreated volume	Comment
Biological treatment	COD		2880	22	4 m <sup>3</sup> /day	<b>99 % elimination</b>
	TOC		855	11		
Activated carbon adsorption	COD	mg/l	21630	1081	20 m <sup>3</sup> /day	
	DOC		12600	2016		
	<b>AOX</b>		<b>1100</b>	<b>99</b>		
	COD		18000	55	11 m <sup>3</sup> /day	
	DOC		9700	11		
	<b>AOX</b>		<b>2900</b>	<b>10</b>		
Cyanide treatment	COD		28700	24200	16 m <sup>3</sup> /day	<b>Health and safety aspects</b>
	DOC		12500	11450		
	AOX		1650	1540		
	<b>CN<sup>-</sup></b>		<b>ppm</b>	<b>280</b>		
Precipitation/filtration	<b>Ni</b>	mg/l	<b>950</b>	<b>9.9</b>		

Table 4.62: Typical examples for the assignment of waste water streams to treatment options (The decisive parameter/cause is highlighted)

### **Achieved environmental benefits**

- the established pretreatment/treatment options enable the operator to handle waste water streams according to the properties
- relief of the biological WWTP.

### **Cross-media effects**

Energy and chemical consumption of the applied techniques.

### **Operational data**

*No information provided.*

### **Applicability**

Generally applicable. Various other combinations of treatment options are successfully applied on OFC sites.

### **Economics**

Economics of the applied treatment options. High investment costs were avoided by off-site solutions, which also enables a future change of strategy.

### **Driving force for implementation**

- adequate treatment of waste water streams
- relief of the biological WWTP.

### **References to literature and example plants**

[91, Serr, 2004], \*010A,B,D,I,X\*

4.3.7.4 Joint pretreatment of waste water streams by wet oxidation with O<sub>2</sub>

## Description

\*088IX\* operates a waste water treatment platform offering the options of wet oxidation of concentrated waste water streams, biological treatment and wet oxidation of sludges (see Figure 4.68). Where necessary, solvents can be removed from individual waste water streams to enable wet oxidation. Blending enables a wide range of input and the wet oxidation runs autothermally in normal operation. The wet oxidation of waste water streams eliminates about 80 % of the COD load with the remaining COD load being highly biologically degradable (organic compounds with low molecular weight). The conversion of critical compounds (e.g. active ingredients) is very high (usually >99 %). Finally, all waste waters are treated in the biological WWTP. Heavy metals are separated after wet oxidation as metal oxides. Overall (wet oxidation and biological treatment), an average COD elimination of >99 % is achieved. The sludges from the biological treatment are also treated by wet oxidation, but under less drastic conditions (lower water content). The effluents from the wet oxidation of the sludges are fed back to the biology.

Table 4.63 gives selected examples for waste water streams pretreated by wet oxidation.

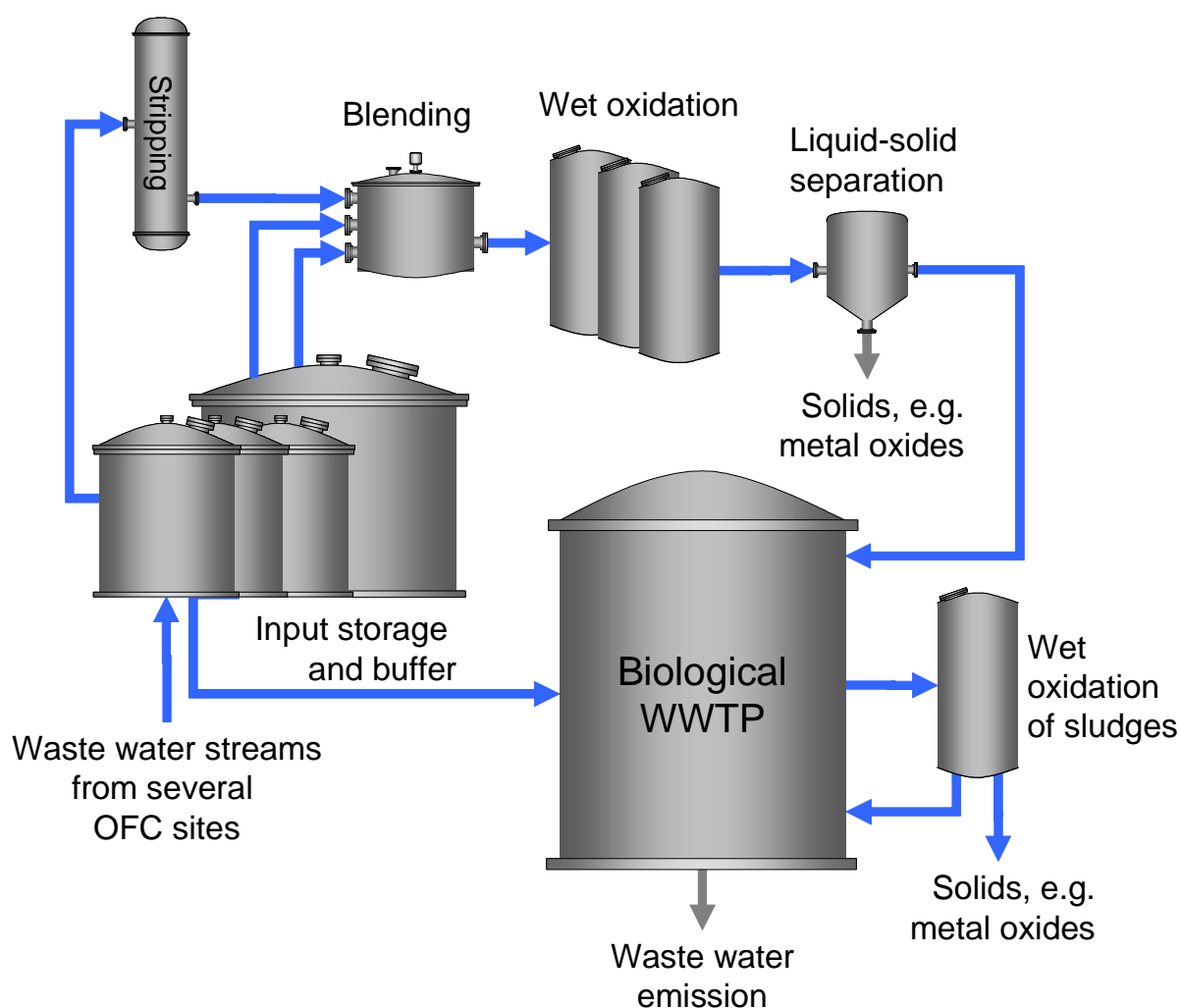

Figure 4.68: Joint pretreatment by wet oxidation with O<sub>2</sub>

The main criteria when considering a waste water stream for wet oxidation are:

- the waste water stream contains active ingredients from API or biocide/plant health product manufacture
- the waste water stream inhibits nitrification in the biological WWTP (inhibition is seen as problematic from 20 % on)
- the waste water stream contains poorly degradable organic load
- the waste water stream contains a high COD load. Independent of the biodegradability, high COD are more efficiently (and more cost effective) treated by wet oxidation
- the waste water stream contains heavy metals
- the waste water stream contains cyanides. Cyanides do not represent a problem since the wet oxidation is operated at pH 12 – 13.

Figure 4.69 shows examples of the assessment of waste water streams and the decisions made.

	Original sample	Wet oxidation	
		Before	After
mg/l			
<b>Yellow wash-waters from biocide production</b>			
Nitrated and chlorinated benzo trifluorides	9700		<15
COD	23600	21991	3435
Chloride	7090	4727	4963
Solvents	470	470	470
<b>Antibiotic production</b>			
COD	70388	32214	3856
BOD <sub>5</sub>		582	2642
BOD <sub>5</sub> /COD		0.02	0.69
Kjeldahl N		39060	32970
Suspended solids		16160	4556
Solvents	284	209	199
<b>Antibiotics production</b>			
COD	1570	1486	191
BOD <sub>5</sub>	580	549	162
BOD <sub>5</sub> /COD	0.37	0.37	0.85
Solvents	52	48	18
<b>API production</b>			
COD	54000	25700	6000
TOC	30000	15000	830
BOD <sub>5</sub>	2000	1000	150
BOD <sub>5</sub> /COD	0.04	0.04	0.03
Cyanides	35000	17500	<1
Chlorides	85000	42500	42500
Nitrate	<1	<1	7500

Table 4.63: Examples and results for waste water streams treated by wet oxidation with O<sub>2</sub>

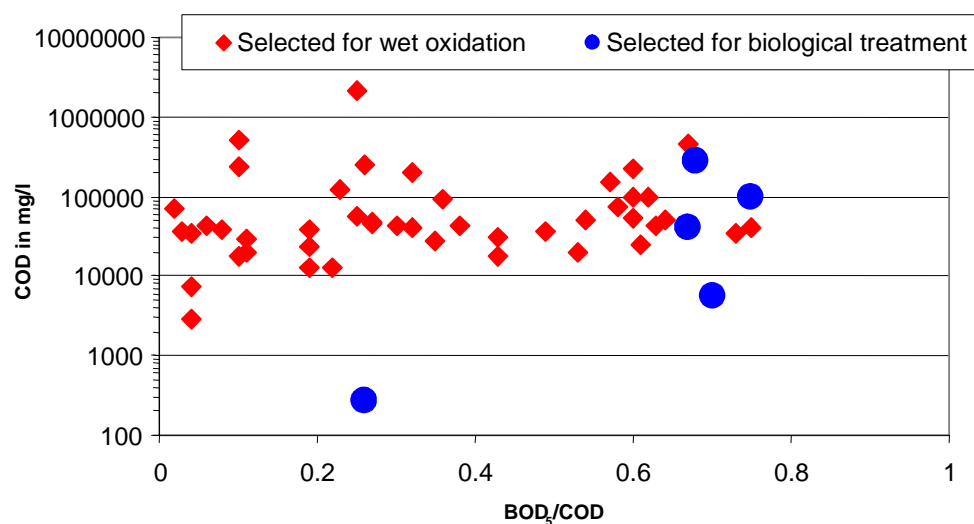

Figure 4.69: Results of the assessment of waste water streams from an external origin

### Achieved environmental benefits

- highly efficient combination of pretreatment and biological treatment of waste water streams
- highly efficient elimination of active ingredients, poorly degradable organic loads, heavy metals, AOX and CHCs
- the sludge problem is solved as well.

### Cross-media effects

- O<sub>2</sub> consumption
- chemicals for pH adjustment
- energy for pumping.

### Operational data

Table 4.64 gives an overview to the operational data of the wet oxidation of waste water streams.

### Applicability

The setup is very flexible and provides a pretreatment option for a wide range of waste water streams. The layout for the single unit is possible from 2 to 25 m<sup>3</sup>/hour. The relatively high investment costs are better justified for larger multipurpose sites or as, in this example, joint pretreatment. The low treatment costs make wet oxidation with O<sub>2</sub> an attractive alternative to biological treatment of waste water streams containing high COD loads. No corrosion problems occur up to a salt content of 8.5 % w/w.

Other examples where wet oxidation with O<sub>2</sub> is applied or planned:

- \*042A,I\*: see Section 4.3.7.11
- \*102X\*: joint treatment platform in construction.

Wet oxidation with O <sub>2</sub>			
Input criteria	COD	10000 – 150000 mg/l	Additionally, blending is possible
	Average input COD	40000 mg/l	
	Volatile organic compounds (solvents)	Up to 2000 mg/l	Stripping is offered as an option
	Chloride, bromide	Up to 85000 mg/l	Additionally, blending is possible
Process conditions	Mode	Continuous, autothermal	
	Throughput	18 m <sup>3</sup> /hour	
	pH	12 – 13	
	Temperature	About 300 °C	
	Pressure	About 100 – 150 bar	
Stripped solvents	External disposal		
Off gas	Temperature	60 °C	
	Treatment	Scrubbing, thermal oxidation with energy recovery	
Output	Average COD removal	80 %	
	Average biodegradability	>95 %	

**Table 4.64: Operational data for the wet oxidation with O<sub>2</sub> on the \*088I,X\* site**

### Economics

- high investment cost
- low operating costs
- wet oxidation: EUR 0.20 – 0.25/kg COD.

### Driving force for implementation

Need for an efficient pretreatment in addition to biological treatment.

### References to literature and example plants

[90, 3V Green Eagle, 2004], [91, Serr, 2004], [92, Collivignarelli, 1999], \*088I,X\*, \*087I\*



### 4.3.7.5 Pretreatment on production sites for biocides/plant health products

#### Description

The production of biocides and plant health products can result in high concentrations of active ingredients in discharged waste waters and high toxicity values for fish and daphnia (see Section 4.3.8.18). Residual measured daily loads after final treatment have been reported for \*047B\* to vary between 5 and 500 g/d per substance whereas other active ingredients produced were below the detection limit. Waste waters from product formulation can cause similar impact on biological WWTPs, even if such waste waters are disposed of via waste disposal companies and are discharged from there after treatment. Therefore, waste waters from the production of biocides/plant health products are currently pretreated especially by means of stripping, extraction, pressure hydrolysis, wet oxidation or activated carbon adsorption. This is illustrated by the examples given in Table 4.66.

#### Achieved environmental benefits

- protection of biological WWTPs
- protection of receiving waters from toxic effects and persistent substances.

#### Cross-media effects

Consumption of energy and chemicals for pretreatment.

#### Operational data

Table 4.65 give operational and performance data for the ozonolysis stage:

Ozonolysis	2.5 m <sup>3</sup> /hour, 15000 m <sup>3</sup> /year	
	Before treatment	After treatment
AOX	50 mg/l	<20 mg/l
Degradability	60 %	90 %
TOC	More or less unchanged	

**Table 4.65: Operational data and performance of the ozonolysis**

#### Applicability

Generally applicable.

#### Economics

Investment costs for ozonolysis: EUR 1000000 (2001).

#### Driving force for implementation

Stipulations concerning AOX in effluents.

#### References to literature and example plants

[53, UBA, 2004], [67, UBA, 2004], \*047B\*

Examples [67, UBA, 2004], [68, Anonymous, 2004]			Pretreatment							
Production of	Unit processes	Waste stream	Extraction	Stripping	Ozonolysis	Wet oxidation	Activated carbon adsorption	Incineration	Precipitation/filtration	
1	Phosphorus acid esters	All waste water streams	X	X						Incineration of the extract, extraction with the same solvent as used for the reaction, final biological treatment on-site and off-site
2	An intermediate for an insecticide	All waste water streams		X	X					Followed by on-site biological treatment
3	An insecticide	All waste water streams				X		X		
4	A plant protection agent	Esterification, coupling, rearrangement				X	X			Mother liquor contains cyanide, and pretreatment is followed by biological treatment. Overall elimination 93 % for COD and AOX. Solvent recovery by two step distillation
5	A plant health product	Substitution							X	Followed by biological treatment, and incineration of the precipitate
6	A plant health product	Dehydratisation, ring closure	X							Followed by biological treatment, and multistage extraction with partial recovery of the extracted active ingredient
7	A urea herbicide	Addition					X			Most of the mother liquor is recycled
8	A herbicide	Addition, substitution					X			

Table 4.66: Pretreatment of waste water streams from the production of biocides/plant health products

### 4.3.7.6 Management of waste water streams (1)

#### Description

The decision whether a particular waste water stream can be forwarded directly to the WWTP is a crucial issue in a multipurpose site. The important criteria are the toxic effects on the activated sludge and the bioeliminability of the organic load.

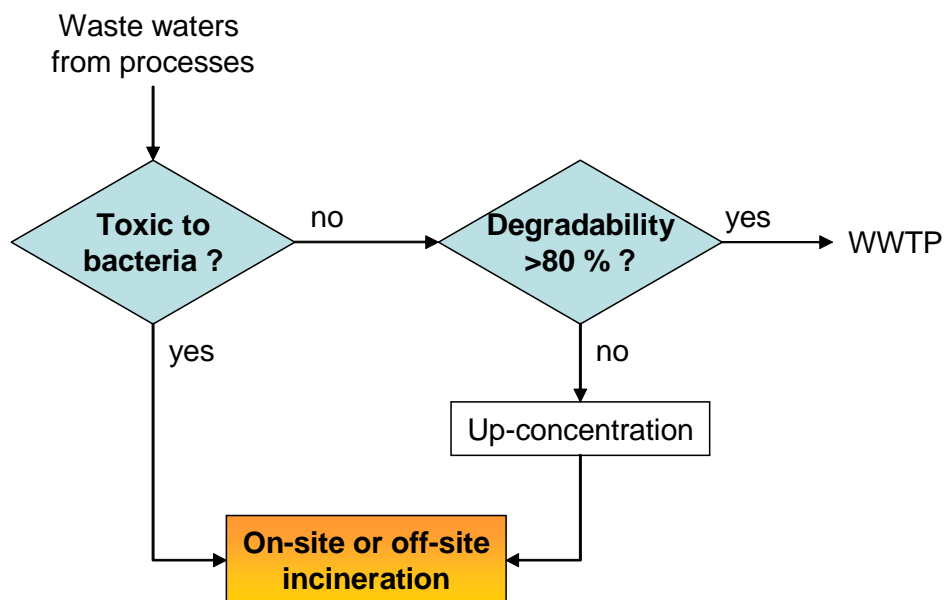

Figure 4.70: Management of waste water streams on the reference plants

#### Achieved environmental benefits

- important decision criteria for managing the waste water streams of an API site
- to ensure high operational stability of the biological WWTP
- avoidance of non-degradable input to WWTP
- achievable overall COD elimination of >95 % (yearly average 2003)
- to achieve BOD elimination of 99.8 % (yearly average).

#### Cross-media effects

Energy consumption for incineration.

#### Operational data

Degradability determined by Zahn-Wellens test.

#### Applicability

Generally applicable. Incineration is not the only pretreatment option. For other examples see Section 4.3.7.1 and 4.3.7.2.

### Economics

Storage, costs for increasing the concentration and incineration.

### Driving force for implementation

- stability of the WWTP
- ELV for release of organic load from WWTP.

### References to literature and example plants

\*015D,I,O,B\*, \*023A,I\*, \*027A,I\*, \*028A,I\*, \*029A,I\*, \*030A,I\*, \*031A,I\*, \*032A,I\*

### 4.3.7.7 Management of waste water streams (2)

#### Description

The decision whether a particular waste water stream can be forwarded directly to the WWTP is a crucial issue in a multipurpose site. The important criteria are the toxic effects on the activated sludge and the refractory portion of the organic load (ROC). As a standard, \*068B,D,I\* considers all waste water streams with a bioeliminability of <80 % for pretreatment.

Other criteria are:

- inhibition of bacteria
- priority substances
- carcinogenic substances
- heavy metals.

The following pretreatment options are available on-site:

- flocculation, filtration/chemical oxidation
- destruction of heavy metal complexes
- precipitation, filtration for heavy metals.

Figure 4.71 shows the decisions made in the reference plant. Exceptions above 80 % bioeliminability occur in cases where one of the other criteria is applicable, leading to pretreatment. Exceptions below 80 % bioeliminability occur where chemical oxidation does not lead to sufficient results (TOC elimination or enhanced biodegradability).

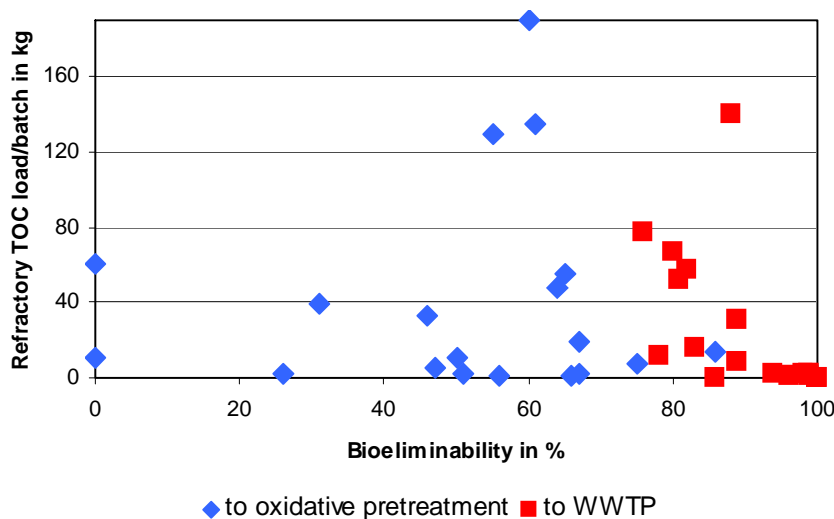

Figure 4.71: Decision made in the reference plant

#### Achieved environmental benefits

- important decision criteria for managing the waste water streams of an OFC site
- to ensure high operational stability of the biological WWTP
- elimination of low degradable TOC before biological treatment
- enhanced biodegradability of the organic input to WWTP.

Table 4.67 shows the effect of the pretreatment on the bioeliminability of the organic load in the total effluent.

Year	Biodegradability of waste water streams selected for pretreatment		Bioeliminability of the total effluent before biological treatment
	Before pretreatment	After pretreatment	
2001	60 %	81 %	91 %
2002	64 %	78 %	92 %

**Table 4.67: Degradability/eliminability of a total effluent after pretreatment of individual waste water streams**

### **Cross-media effects**

Chemicals and energy consumption for pretreatment.

### **Operational data**

Biodegradability of waste water streams is determined by an OECD screening test, bioeliminability of the total effluent before biological treatment is determined by inherent biodegradability testing (see also Section 2.4.2.4 and 4.3.1.3).

### **Applicability**

Generally applicable.

### **Economics**

Costs for pretreatment.

### **Driving force for implementation**

- stability of the WWTP
- ELV for the bioeliminability of the organic input to the WWTP.

### **References to literature and example plants**

[91, Serr, 2004], \*068B,D,I\*

### 4.3.7.8 Management of waste water streams (3)

#### Description

The decision whether a particular waste water streams can be forwarded directly to the WWTP is a crucial issue in a multipurpose site. The important criteria are the toxic effects on the activated sludge and especially the refractory portion of the organic load. As a standard, \*0089A,I\* considers all waste water streams with a bioeliminability <90 % from Zahn-Wellens test for disposal.

The lower refractory load in the effluent enables the plant to operate a final activated carbon filter efficiently as an AOX guard.

#### Achieved environmental benefits

- important decision criteria for managing the waste water streams of an OFC site
- to ensure high operational stability of the biological WWTP
- elimination of low degradable TOC before biological treatment.

#### Cross-media effects

Cross-media effects of the disposal technique.

#### Operational data

Degradability of waste water streams determined by a Zahn-Wellens test.

#### Applicability

Generally applicable.

#### Economics

Costs for disposal.

#### Driving force for implementation

- stability of the WWTP
- lower emissions of refractory organic load.

#### References to literature and example plants

\*068B,D,I\*

### 4.3.7.9 Waste water streams for obligatory pretreatment or disposal

#### Description

In some cases, due to their characteristic properties (e.g. high toxicity) certain mother liquors (see Table 4.68) should not be treated in biological WWTPs and have to be pretreated (recovery or abatement) or disposed of (incineration).

Waste water streams	Critical parameters	Reference
Mother liquors from halogenations	High AOX loads due to side reactions, toxicity	*001A,I*, *006A,I*, *007I*, *017A,I*, *018A,I*, *019A,I*, *020A,I*, *023A,I*, *024A,I*, *027A,I*, *028A,I*, *029A,I*, *030A,I*, *030A,I*, *031A,I*, *032A,I*
Process waters, condensates and regenerates from manufacture of active ingredients showing toxicity to bacteria	Toxicity to bacteria, jeopardising or reducing the functionality of biological WWTP	[15, Köppke, 2000]
Waste water streams from production or formulation of active ingredients	Remaining toxicity levels after biological WWTP, expressed e.g. as LID <sub>F</sub> , LID <sub>D</sub> , LID <sub>A</sub>	[62, D1 comments, 2004]
Waste acids, e.g. from sulphonations, nitrations	Usually high COD load with low bioeliminability	[15, Köppke, 2000], *026E*, *044E*, *045E*

**Table 4.68: Waste water streams for obligatory pretreatment or disposal**

#### Achieved environmental benefits

- relief of the biological WWTP from toxic/inhibiting/low degradable input
- lower AOX loadings in effluents
- lower toxicity in effluents
- avoidance of neutralisation of highly acidic portions.

#### Cross-media effects

Depends on the pretreatment technique.

#### Operational data

Depends on the pretreatment technique.

#### Applicability

Generally applicable.

#### Economics

Higher costs for pretreatment or disposal.



**Driving force for implementation**

Recovery of raw material or product. Reduction of waste water treatment costs.

**References to literature and example plants**

See Table 4.68.

## 4.3.7.10 Refractory organic loadings (1)

## Description

The decision whether a particular waste water stream should be pretreated or forwarded directly to the biological WWTP is a crucial issue in a multipurpose site. The important criterion is the organic load caused by a process and the refractory portion of it, as this passes a biological treatment unchanged:

$$\text{refractory load} = \text{organic load} \times (100 - \text{elimination \%})$$

*Refractory TOC loads higher than about 40 kg per batch (or day) are treated by oxidation (or methods which reach a comparable performance) upstream of a biological WWTP.*

For illustration, see the example given in Table 4.69:

Example: Oxidative coupling of two intermediates				
Precipitation, filtration, product washing				
	TOC load/batch	Elimination (Zahn-Wellens)	Refractory TOC load/batch or/day	Destination
Mother liquor	180 kg	35 %	117 kg	Wet oxidation
Wash-water	50 kg	65 %	17.5 kg	WWTP

Table 4.69: Example of the assessment of the refractory organic load from a process

Figure 4.72 shows the decisions made in the reference plants.

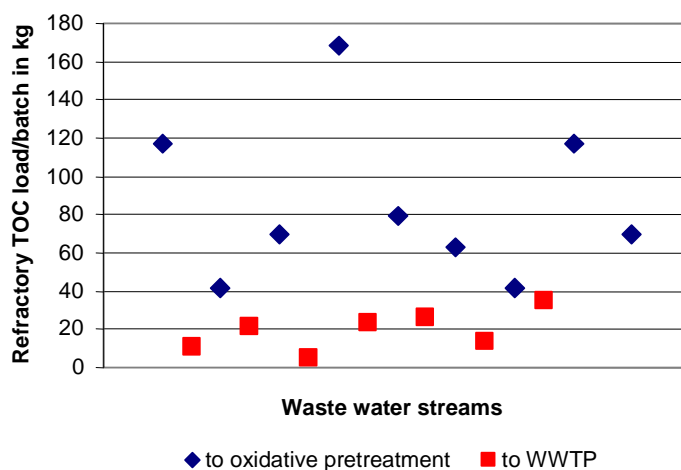

Figure 4.72: Decisions made in the reference plants

## Achieved environmental benefits

- important decision criterion for managing the waste water streams of a multipurpose site
- a tool that enables operators and authorities to prioritise and focus on waste water streams with a high reduction potential
- effective strategy, even for sites with difficult product mixes
- reduction of the emission of refractory organic loads, e.g. 98 % removal of refractory load in segregated waste water streams in the case of \*015D,I,O,B\*.

### Cross-media effects

For cross-media effects, see the text on each particular pretreatment technique.

### Operational data

*No information provided.*

### Applicability

Particularly applicable in cases where a product mix with many poorly degradable waste water streams requires the setting of priorities, assuming that it is not possible to pretreat all the waste water streams.

In particular cases, technical restrictions may prevent pretreatment [62, D1 comments, 2004]. For example, a mother liquor from the production of an intermediate for a dyestuff shows the following refractory TOC load (see also example 3 in Table 4.34):

- 70 to 90 kg (10 – 30 % elimination after according to Zahn-Wellens test).

*Despite these values, the mother liquor is treated in the biological WWTP only. Pretreatment is not applied, because:*

- on-site wet oxidation is not possible due to oily precipitates in the up-concentration stage
- incineration appeared inefficient due to the actual TOC concentration
- the disposal as waste acid is not possible due to the concentration of H<sub>2</sub>SO<sub>4</sub> of 20 – 25 % and the actual TOC concentration.

### Economics

Additional costs from applying a particular pretreatment technique, although some benefits do result. Establishing pretreatment options for waste water streams occurring only occasionally (rare batch production) is economically not viable. In the case of \*015D,I,O,B\*, waste water streams are only considered for pretreatment if the refractory load exceeds 2 tonnes TOC per year [99, D2 comments, 2005].

### Driving force for implementation

There is a need for defining a cut-off criterion.

### References to literature and example plants

\*014V,I\*, \*015D,I,O,B\*

### 4.3.7.11 Refractory organic loadings (2)

#### Description

Due to the lower costs and a payback time of about 5 – 6 years, \*042A,I\* considers the step-by-step replacement of off-site waste water incineration by on-site wet oxidation. Candidates for such pretreatment are high loaded or toxic waste water streams.

As a basis for planning, typical waste water streams (until now considered for waste water incineration) with the following properties are used:

- TOC: 15 g/l or higher
- volume: 20 m<sup>3</sup>.

#### Achieved environmental benefits

- important decision criterion for managing the waste water streams of a multipurpose site
- tool that enables operators and authorities to prioritise and focus on waste water streams with a high reduction potential
- effective strategy, even for sites with difficult product mixes
- reduction of the emission of refractory organic loads.

#### Cross-media effects

For cross-media effects, see the text on each particular pretreatment technique.

#### Operational data

*No information provided.*

#### Applicability

Generally applicable.

#### Economics

Additional costs from applying a particular pretreatment technique, although some benefits do result.

#### Driving force for implementation

There is a need to find a cut-off criterion.

#### References to literature and example plants

[91, Serr, 2004], \*042A,I\*

### 4.3.7.12 Refractory organic loadings (3)

#### Description

\*082A,I\* considers waste water incineration as a technique to relieve the biological WWTP from waste water streams containing high refractory loadings according to the following criteria:

- bioeliminability <80 %
- refractory loading (TOC): 7.5 – 28 kg or higher.

#### Achieved environmental benefits

- important decision criteria for managing the waste water streams of a multipurpose site
- a tool that enables operators and authorities to prioritise and focus on waste water streams with a high reduction potential
- effective strategy, even for sites with difficult product mixes
- reduction of the emission of refractory organic loads.

#### Cross-media effects

For cross-media effects, see the text on each particular pretreatment technique.

#### Operational data

*No information provided.*

#### Applicability

Generally applicable.

#### Economics

Additional costs from applying a particular pretreatment technique, although some benefits do result.

#### Driving force for implementation

There is a need to find a cut-off criterion.

#### References to literature and example plants

[91, Serr, 2004], \*082A,I\*

## 4.3.7.13 Refractory organic loadings (4)

## Description

\*001A,I\* considers waste water incineration as a technique to relieve the biological WWTP from waste water streams containing high refractory loadings according to the following criteria:

- bioeliminability >80 %
- refractory loading (TOC): <40 kg.

Figure 4.73 shows the decisions made at the \*001A,I\* site (2002). The exception from the rule is a mother liquor with a refractory TOC load of about 95 kg/batch but high bioeliminability.

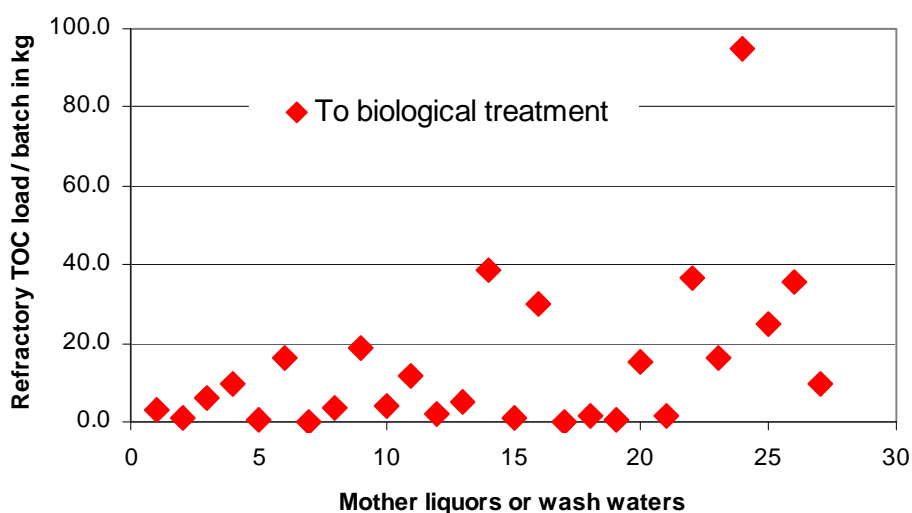

Figure 4.73: Decisions made in the reference plant

Note: only the data for mother liquors/wash-waters treated biologically were provided, process waters with a higher refractory organic load are considered for incineration

## Achieved environmental benefits

- important decision criteria for managing the waste water streams of a multipurpose site
- a tool that enables operators and authorities to prioritise and focus on waste water streams with a high reduction potential
- effective strategy, even for sites with difficult product mixes
- reduction of the emission of refractory organic loads.

## Cross-media effects

For cross-media effects see the text on each particular pretreatment technique.

## Operational data

*No information provided.*

## Applicability

Generally applicable.

### **Economics**

Additional costs from applying a particular pretreatment technique, although some benefits do result.

### **Driving force for implementation**

There is a need to find a cut-off criterion.

### **References to literature and example plants**

\*001A,I\*

## 4.3.7.14 AOX elimination from waste water streams (1)

**Description**

AOX is a well established screening parameter for the assessment of halogenated organic compounds in an aqueous solution and is a basis for the development of improvement strategies. The main sources for waste water streams with relevant AOX load are processes/operations involving:

- halogenated solvents
- halogenated intermediates, products and by-products.

Elimination of AOX from such waste water streams can be carried out principally by the application of pretreatment techniques for refractory organic loads or by specific treatment techniques. Table 4.70 shows the example from \*014V,I\*.

	Examples for AOX loaded streams	WWTP	
		AOX input	AOX discharged
		Average 2000	
Low pressure wet oxidation	120 mg/l AOX 16 m <sup>3</sup> /day	2710 kg 1.1 mg/l	339 kg 0.13 mg/l
	60 mg/l AOX 50 m <sup>3</sup> /day		
	And others		
Hydrolysis with NaOH	145 mg/l AOX 5 m <sup>3</sup> /day	2003: 0.9 mg/l	2003: 0.11 mg/l
	130 mg/l AOX 2 m <sup>3</sup> /day		
	And others		

**Table 4.70: AOX elimination and resulting releases after biological waste water treatment**

**Achieved environmental benefits**

- relief of the biological WWTP
- less halogenated organic compounds are emitted.

Other examples of resulting input and emission levels into and out of biological WWTPs are given in Table 4.71 and illustrated in Figure 4.74.

**Cross-media effects**

Energy and chemicals consumption for the applied treatment techniques.

**Operational data**

*No information provided.*

**Applicability**

Generally applicable. Hydrolysis is only effective with side-chain halogenated organic compounds [99, D2 comments, 2005].



		Biological WWTP	
		Input	discharge
		AOX yearly average mg/l	
*009A,B,D* (2000)	Central activated carbon facility	1.1	0.16
*009A,B,D* (2002)		1.8	0.15
*010A,B,D,I,X* (2000)	Stripping of C1-CHC, distillation of waste water streams	14 <sup>a)</sup>	0.9 <sup>a)</sup>
*010A,B,D,I,X* (2003)		3.8	0.68
*011X* (2000)	Distillation of waste water streams	1.5	0.25
*011X* (2003)			0.14
*012X* (2000)	Wet oxidation with H <sub>2</sub> O <sub>2</sub>		0.3
*012X* (2003)			0.34
*013A,V,X*	Stripping of waste water streams with high concentrations of purgeable AOX		0.4
*015D,I,O,B*	High pressure wet oxidation, adsorption/extraction	8.5	1.7
*055A,I*	Stripping of CHC, adsorption to activated carbon, incineration	1.5	
*059B,I*	Adsorption to activated carbon	4 – 8	
*068B,D,I*	Chemical oxidation		1.5
*069B*	Extraction	8	
*082A,I*	Combination of stripping, rectification, extraction to remove CHC from waste water streams	1.17	
*100A,I*	Occasionally activated carbon addition to activated sludge, segregation and disposal (incineration)	0.8 <sup>b)</sup>	0.3 <sup>b)</sup>
008A,I (1997)	Individual pretreatment: extractions, activated carbon adsorption, precipitation/filtration, process changes, combination of bioreactor and activated carbon adsorption, segregation and disposal (incineration)	1.44	0.84
008A,I (1998)		0.75	0.42
008A,I (1999)		0.64	0.54
008A,I (2000)		0.95	0.81
008A,I (2001)		0.89	0.45
008A,I (2002)		0.70	0.40
008A,I (2003)		0.57	0.18

<sup>a)</sup> The highest value (14 mg/l) as input is due to exceptionally well degradable waste water streams from production of acetaldehyde (93.4 %)

<sup>b)</sup> Different analytical method, result expressed as EOX

Table 4.71: Other examples for AOX elimination

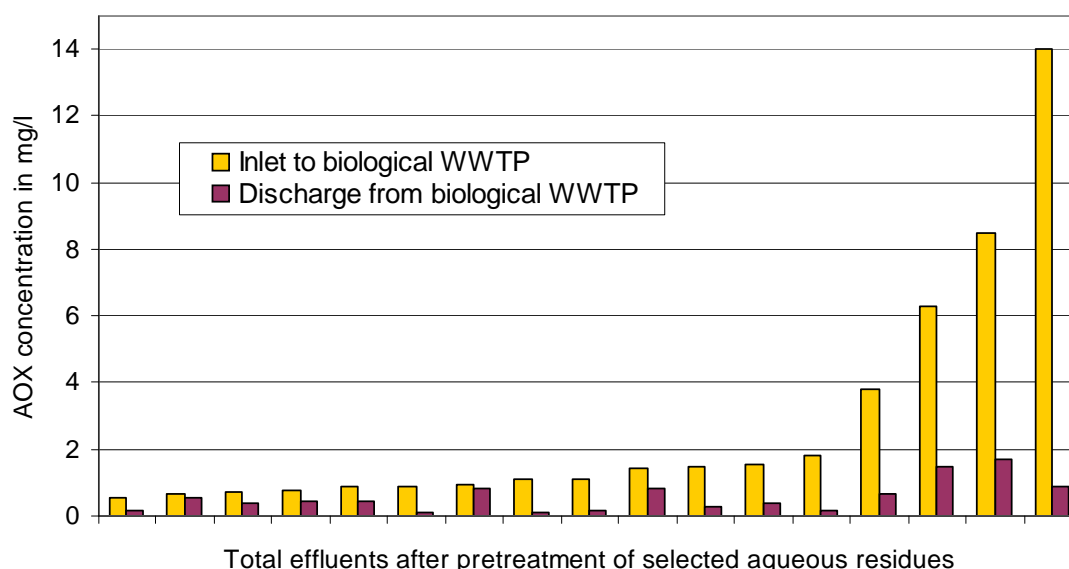

Figure 4.74: AOX concentrations of inlet to and discharge from biological WWTPs

### **Economics**

Economics of the applied treatment techniques.

### **Driving force for implementation**

Legislation.

### **References to literature and example plants**

[84, Meyer, 2004], see Table 4.71, \*014V,I\*

### 4.3.7.15 AOX elimination from waste water streams (2)

#### Description

AOX is a well established screening parameter for the assessment of halogenated organic compounds in an aqueous solution and is a basis for the development of improvement strategies. The main sources for waste water streams with relevant AOX load are processes/operations involving:

- halogenated solvents
- halogenated intermediates, products and by-products.

Elimination of AOX from such waste water streams can be carried out principally by the application of pretreatment techniques for refractory organic loads or by specific treatment techniques. Figure 4.75 shows the example from \*055A,I\*. For illustration, Table 4.72 shows the effect of the pretreatment on the AOX input concentration to the biological WWTP.

A first criterion to select a waste water stream for pretreatment is a concentration of >30 mg/l AOX and the biodegradability. Where only small numbers of batches are produced also the AOX load is taken into account.

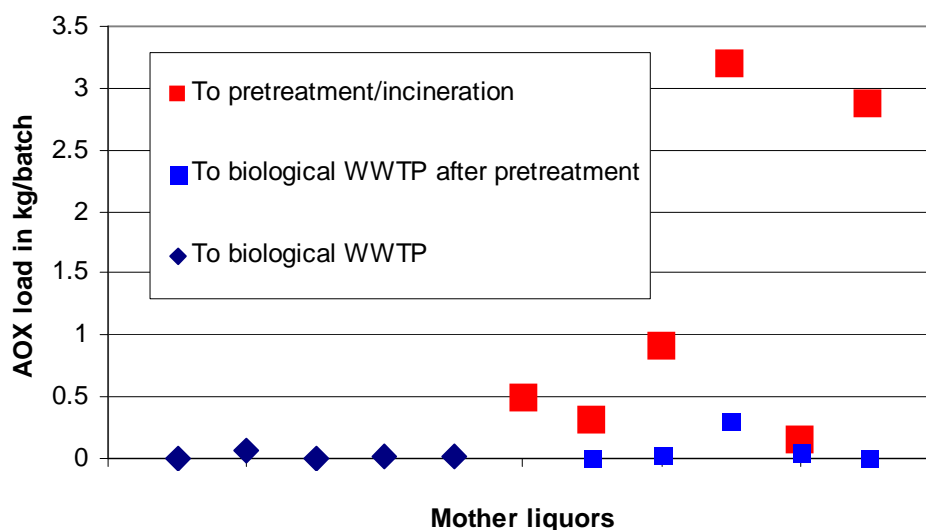

Figure 4.75: Treatment of waste water streams containing AOX

*055A,I*: five selected waste water streams containing AOX					
AOX load without pretreatment (kg)	0.31	0.91	3.19	0.14	2.78
AOX load after pretreatment (kg)	0.005	0.03	0.3	0.055	0.004
AOX level added to a total effluent of 2000 m <sup>3</sup> before biological treatment					
Without pretreatment	3.67 mg AOX/l				
With pretreatment	0.20 mg AOX/l				

Table 4.72: Illustration of the effect of pretreatment on the AOX input to the biological WWTP

#### Achieved environmental benefits

- relief of the biological WWTP
- 2002: input of 1.53 mg/l AOX to the biological WWTP (about 2000 m<sup>3</sup>/day)
- less halogenated organic compounds are emitted
- a biodegradability of 75 – 80 % is achieved for AOX in the biological WWTP.

### **Cross-media effects**

Energy and chemicals consumption for the applied treatment techniques.

### **Operational data**

Pretreatment is carried out by:

- stripping
- adsorption to activated carbon
- specific reactions
- disposal (incineration).

### **Applicability**

Generally applicable.

### **Economics**

Economics of the applied treatment techniques.

### **Driving force for implementation**

Legislation.

### **References to literature and example plants**

[33, DECHEMA, 1995], [91, Serr, 2004], \*055A,I\*

### 4.3.7.16 AOX elimination from waste water streams (3)

#### Description

On the \*082A,I\* site, waste water streams from the manufacture of highly active ingredients are pretreated by means of reverse osmosis (see Figure 4.76). The guiding parameter to track the halogenated compounds is AOX. Table 4.73 gives an overview to the typical properties of the waste water streams considered for pretreatment.

	Unit	Min	Max	Mean
COD	mg/l	1000	25000	5000
AOX	mg/l	4	50	30
Active ingredient	mg/l	500	2000	1000
pH		3	8	7
Temperature	°C	20	50	30

Table 4.73: Typical properties of the waste water streams in the example case

The membrane system is realised as a two stage system with different membrane types. The organic load in the permeate is non-biodegradable and is discharged via the biological WWTP. In this case, the concentrate cannot be re-used in the process and is disposed of (incineration).

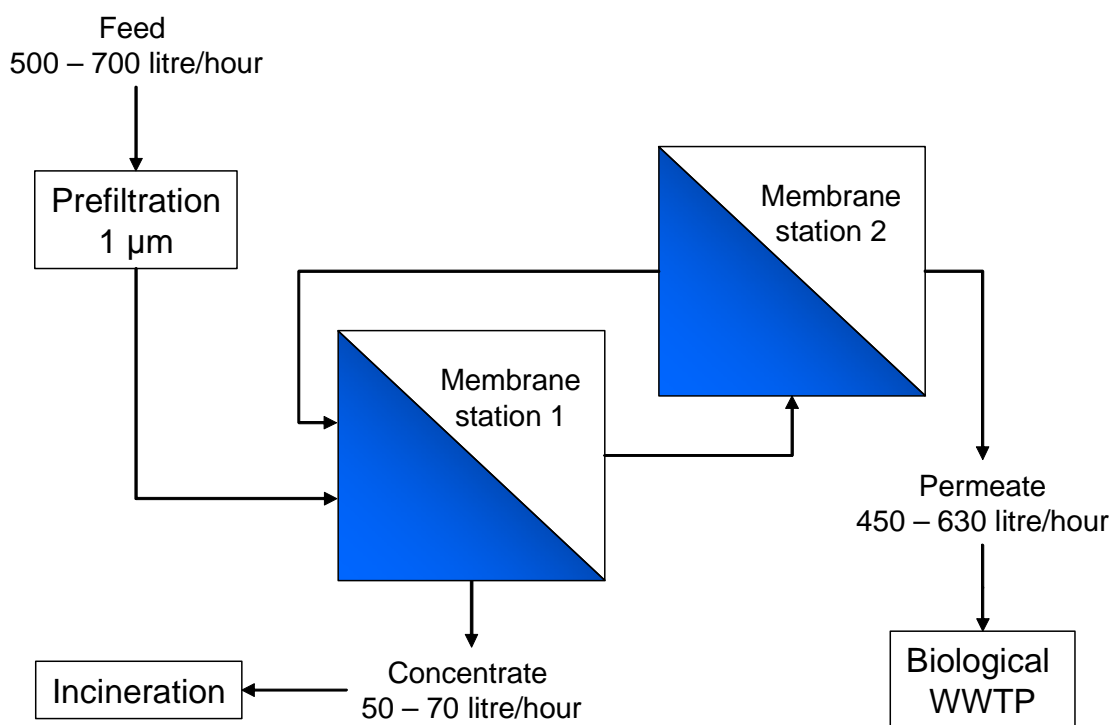

Figure 4.76: Two stage membrane setup for the removal of AOX from waste water streams

#### Achieved environmental benefits

- achievable AOX in the permeate: 0.5 mg/l (99.99 % removal related to the mean input)
- relief of the receiving water body
- the up-concentration reduces the amount to be disposed of by 90 % (incineration).

### **Cross-media effects**

Energy consumption.

### **Operational data**

- two stage setup, polyamid, active composite-type
- stage 1: 8" modules DVA 003 "wide spacer type"
- stage 2: 8" modules ROM 103 "standard spacer type"
- membrane surface of about 160 m<sup>2</sup>.

### **Applicability**

Membrane type and layout depend on the separation task. In the given example the membrane was operated for 4000 hours without loss of performance.

### **Economics**

*No information provided.*

### **Driving force for implementation**

Relief of the receiving water body.

### **References to literature and example plants**

[82, Baumgarten, 2004], \*082A,I\*

#### 4.3.7.17 AOX: removal of iodine compounds from waste water streams by means of nanofiltration

##### Description

Wash-waters from the production of X-ray contrast media contain about 1000 ppm iodine since derivatives of 2,4,6-triiodine benzoic acid are frequently involved. The relevant compounds can be ionic or non-ionic, show molecular weights from 600 to 1600 g/mol, and are poorly biodegradable.

On the \*082A,I\* site, such wash-waters are collected separately and removed from the waste water stream by means of a 2-stage nanofiltration. In the first stage, the iodine compounds are concentrated up to 60 g/l, and the second stage ensures a permeate concentration below 1 ppm AOX.

##### Achieved environmental benefits

Relief of the biological WWTP and the receiving water body from a poorly degradable organic load.

##### Cross-media effects

Energy consumption.

##### Operational data

- NFM1 membrane, polyamide, negative surface
- feed: 1 m<sup>3</sup>/h (peak flow of 36 m<sup>3</sup>/d possible), 20 bar, 20 °C, concentrations up to 3 g/l
- stage 1: 8" modules "wide spacer" type, 100 m<sup>2</sup>
- stage 2: 8" modules "normal spacer", 64 m<sup>2</sup>
- 99.97 % iodine elimination.

##### Applicability

Membrane type and layout depend on the separation task.

##### Economics

Compared to alternative waste water incineration, costs are 6 % lower.

##### Driving force for implementation

Relief of the receiving water body, and emission limits.

##### References to literature and example plants

[82, Baumgarten, 2004], \*082A,I\*

### 4.3.7.18 Removal of CHCs and solvents from waste water streams

#### Description

On the \*082A,I\* site, all waste water streams containing (mixtures of) solvents are treated by stripping, rectification and extraction or combinations of these techniques in order to remove the solvents. Table 4.74 gives an overview to input and output levels. The recovered solvents are further purified for internal or external re-use or are used as a substitute fuel for the on-site incinerator.

	Input g/l	Output g/l	Removal of	CHC content
Stripping with air	2 – 12		CHCs	<1 mg/l
Rectification	10 – 200	0.1 - 1		<1 mg/l
Extractive rectification	50 – 200	1 - 10	Alcohols	<1 mg/l
Extraction	100 – 250	0.8 - 25	DMF Alcohols	<1 mg/l
		0.5 - 10 0.3 - 20		

**Table 4.74: Removal of solvents from waste water streams in the example of \*082A,I\***

Due to the optimised removal of solvents (which are usually readily degradable), the COD elimination rate in the central biological WWTP is lower (about 90 %).

#### Achieved environmental benefits

- less valuable solvent lost to the WWTP
- intensified use of the biological WWTP
- pretreated waste waters contain <1 mg/l chlorinated hydrocarbons
- lower emissions of CHCs with the effluent
- reduction of diffuse emissions of CHCs from the WWTP.

#### Cross-media effects

Energy consumption.

#### Operational data

- rectification column: 3 – 4 m<sup>3</sup>/h
- extraction: 1 m<sup>3</sup>/h
- stripping: with air: 1 – 2 m<sup>3</sup>/h.

#### Applicability

Generally applicable.

Methanol recovery is often not economically viable due to the low market price. This is especially the case for waste water streams with low methanol concentrations. As described in Section 4.3.5.9, a methanol concentration of >14.5 g/l alters the economic situation and favours stripping and thermal oxidation instead of degradation in a biological WWTP.



An example from \*055A,I\*:

- target for toluene: 0.5 g/l
- target for THF/DMF: 0.3 g/l.

An example from \*016A,I\*:

Target for solvents (sum): 1 g/l.

Besides the economic or energetic balance, the removal of solvents from waste water streams can be also required in order to protect downstream pretreatment facilities, such as activated carbon adsorption [99, D2 comments, 2005].

### **Economics**

Treatment costs: about EUR 67/m<sup>3</sup> (2003).

### **Driving force for implementation**

Recovery of valuable solvents.

### **References to literature and example plants**

[83, Gebauer, 1995], \*055A,I\*, \*016A,I\*, \*082A,I\*

### 4.3.7.19 Removal of CHCs from waste water streams (2)

#### Description

On the \*055A,I\* site, all waste water streams containing a relevant load of chlorinated hydrocarbons, especially chlorinated solvents such as  $\text{CH}_2\text{Cl}_2$  (R40),  $\text{HCCl}_3$  (R22, R38, R40, R48/20/22) are collected separately and pretreated by a combination of stripping and distillation. Figure 4.77 illustrates the selection for such pretreatments.

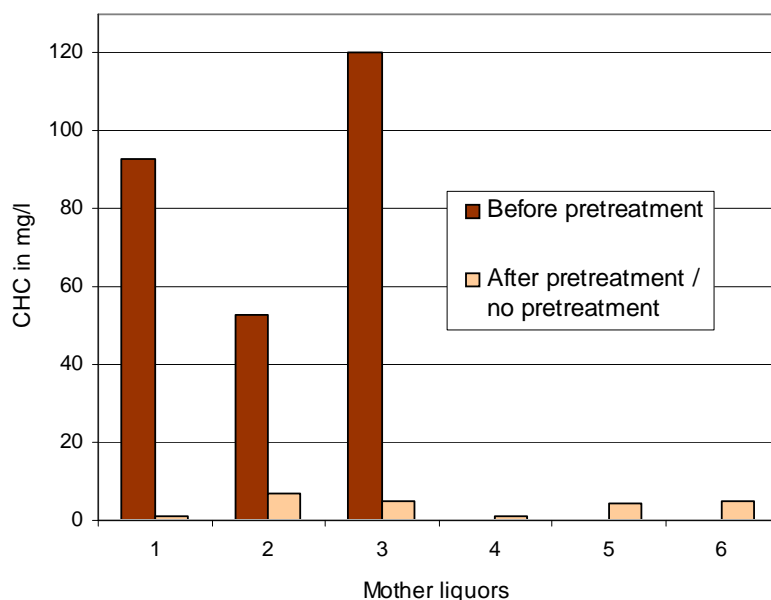

Figure 4.77: Pretreatment of CHCs

#### Achieved environmental benefits

- lower emissions of CHCs with the effluent
- CHC input to the biological WWTP: 0.13 mg/l (2002)
- reduction of diffuse emissions of CHCs from the WWTP.

#### Cross-media effects

Energy consumption.

#### Operational data

*No information provided.*

#### Applicability

Generally applicable.

#### Economics

*No information provided.*

**Driving force for implementation**

Protection of the neighbourhood and receiving water.

**References to literature and example plants**

\*055A,I\*, \*043A,I\*, \*088I,X\*, [33, DECHEMA, 1995], [91, Serr, 2004]

#### 4.3.7.20 Removal of CHCs from waste water streams (3)

##### Description

On the \*014V,I\* site, exhaust gases from a buffer tank and both biological steps of the WWTP containing stripped  $\text{CH}_2\text{Cl}_2$ , are treated by adsorption on activated carbon.

##### Achieved environmental benefits

Reduction of diffuse emissions of CHCs from the WWTP.

##### Cross-media effects

Cross-media effects of activated carbon adsorption.

##### Operational data

*No information provided.*

##### Applicability

Generally applicable.

##### Economics

*No information provided.*

##### Driving force for implementation

Reduction of diffuse emissions.

##### References to literature and example plants

\*014V,I\*

### 4.3.7.21 Removal of nickel from process waters

#### Description

Nickel is frequently used as a Raney nickel catalyst for hydrogenations. On completion of the reaction, the catalyst is removed for regeneration and re-use. Depending on the conditions, a relevant portion of nickel remains in the solution and requires further treatment in a two stage ion-exchanger, whereas the second ion-exchanger is meant for back-up. Figure 4.78 gives an overview to the setup operated in \*018A,I\*.

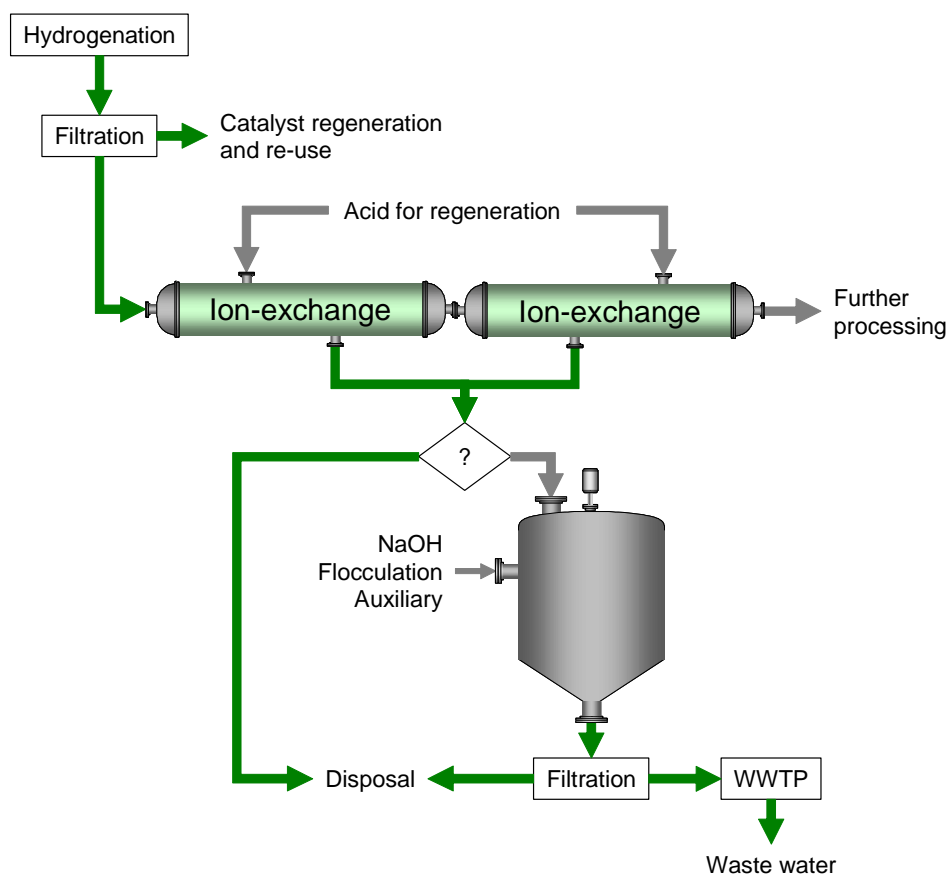

Figure 4.78: Removal of nickel from process waters

#### Achieved environmental benefits

- avoidance of spreading Ni to other process steps
- reduction of the Ni concentration to <math><0.5\text{ mg/l}</math>
- reduction of the Ni load in the sludge from WWTP
- increased efficiency of the WWTP, as Ni inhibits activated sludge performance.

#### Cross-media effects

- additional acid consumption
- consumption of the flocculation auxiliary
- shift of the Ni load from waste water to a waste pathway.

#### Operational data

- Ni in the regenerate: 2600 to 13500 mg/l
- volume per batch: 700 litre.

## Applicability

Generally applicable for heavy metals with similar setups, depending on the particular conditions.

In other cases, the sequence of chemical precipitation followed by ion exchange may be more effective [62, D1 comments, 2004].

The elimination of heavy metals from process waters can be hindered by the organic matrix, e.g. by complex formation or low efficiency of the ion-exchanger [62, D1 comments, 2004].

- **hydroxide precipitation:** solutions of nickel or many other base metal ions are precipitated almost quantitatively by sodium hydroxide or caustic soda or mixtures of them at pH values of between 7.0 and 9.5. Filter aids and flocculants are very useful [62, D1 comments, 2004]
- **sulphide precipitation:** down to the ppb-area, the purification of heavy metals is possible with sulphides, polysulphides and, in best practice, with the non-toxic water soluble sodium-trimercaptotriazine, TMT. For the TMT precipitation of nickel, e.g. the best conditions are: 1 g Ni is co-precipitated with 20 ml of a 15 % Na<sub>3</sub>TMT solution and 0.5 % aluminium solution at pH 12. After rapidly stirring for one minute, followed by slow agitation for 15 minutes, the filtrate contains less than 0.4 mg per litre [62, D1 comments, 2004]
- **general:** all these water treatment processes are also successful in combination [62, D1 comments, 2004].

## Economics

Because the ion-exchangers are unavoidable for further process steps, only the costs for treatment/disposal of the regenerate are compared in Table 4.75:

External disposal	EUR (2001)	Precipitation and filtration	EUR (2001)
Capital cost for storage tank	216000 – 254000	Skid unit and filters	178000 +/-10 %
Disposal costs	185000 per year	Engineering	25000
		Subsequent treatment in WWTP	

**Table 4.75: Costs for precipitation and filtration of the regenerate in comparison to disposal costs**  
Currency was converted from IEP to EUR using the conversion factor 1 EUR = 0.787564 IEP

Economic benefits:

- increased performance of the WWTP
- lower disposal costs for sludge from the WWTP.

## Driving force for implementation

- avoidance of Ni in further processing
- ELV for heavy metals.

## References to literature and example plants

[15, Köppke, 2000], \*018A,I\*

### 4.3.7.22 Heavy metals removal from waste water streams

#### Description

The main sources for waste water streams with heavy metal loads are:

- metallisations, oxidations, reductions with heavy metals as reactant or
- processes where heavy metals are used as catalyst.

For examples of waste water streams, see Table 2.17. On the \*068B,D,I\* site, heavy metals are used extensively, e.g. for metallisations, and the created waste water streams also contain heavy metal complex compounds. These waste water streams are treated individually in order to remove the heavy metal content, including a step for the destruction of metal complex compounds where required.

Figure 4.79 shows how waste water streams containing heavy metal were selected for individual heavy metal treatment and Table 4.76 gives the resulting values for the total effluent before and after the biological WWTP. All waste water streams which are forwarded to the biological treatment plant without heavy metal treatment contain <5 mg/l Cu, Cr, Ni or Zn.

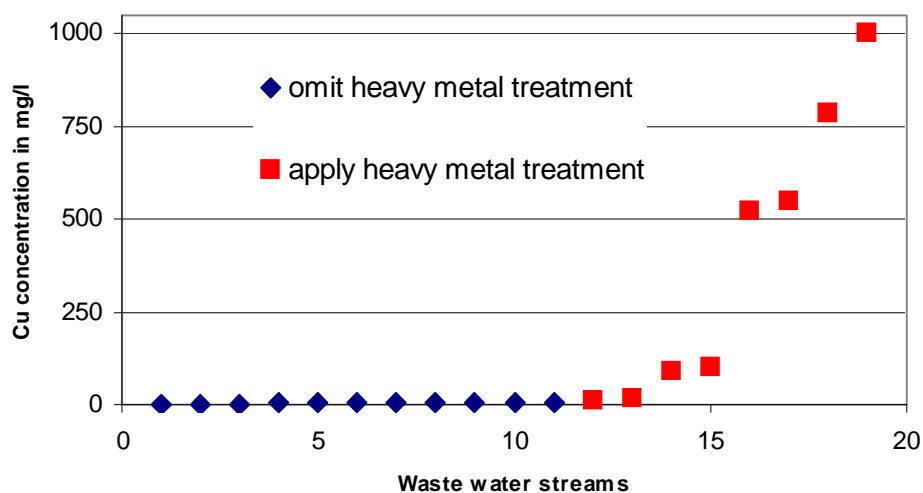

Figure 4.79: Selection of waste water streams for heavy metal treatment

		Heavy metals from *068B,DI* before WWTP	Heavy metals discharged from WWTP
		Yearly average mg/l	
Precipitation and filtration	Cu	0.41	0.02
	Cr	0.31	0.03
	Ni	0.08	0.03
Destruction of heavy metal complex compounds with Na <sub>2</sub> S <sub>4</sub> O <sub>4</sub> , precipitation, filtration	Zn	0.49	
	Pb	0.1	
	Cd	0	
	Hg	0.004	

Table 4.76: Heavy metal removal from waste water streams and the resulting emission level  
Note that after heavy metal treatment, the waste waters are mixed with other waste waters (dilution)

**Achieved environmental benefits**

- relief of the biological WWTP
- lower heavy metal emissions to water.

Other examples are given in Table 4.77.

			Heavy metals from reference plant before WWTP	Heavy metals discharged from WWTP
Yearly average, mg/l				
Precipitation, filtration	015D,I,O,B <sup>1</sup>	Cr	0.13	0.05
		Cu	0.29	0.14
	014V,I <sup>2</sup>	Ni	0.07	0.03
	010A,B,D,I,X (2003)	Cr	0.05	0.004
		Cu	0.10	0.007
		Ni	0.10	0.04
		Zn		0.017
	009A,B,D (2002)	Cr	0.04	0.003
		Cu	0.03	0.007
		Ni	0.03	0.02
		Zn	0.15	0.04
		013A,V,X	Ni	
Note that after heavy metal treatment, the waste waters are mixed with other waste waters (dilution)				
<sup>1</sup> *015D,I,O,B*: destruction of Cu complex compounds (wet oxidation)				
<sup>2</sup> *014V,I* removes heavy metals (especially Zn) from exhaust gases before scrubbing				

**Table 4.77: Other examples for heavy metal removal and resulting emission levels**

**Cross-media effects**

Energy and chemical consumption for the applied treatment techniques.

**Operational data**

*No information provided.*

**Applicability**

At the reference plant 068B,D,I, heavy metals are used extensively and the achieved heavy metal levels before input into the biological WWTP show a worst case.

If equivalent removal levels can be demonstrated in comparison with the combination of pretreatment and biological waste water treatment, heavy metals can be eliminated from the total effluent using only the biological waste water treatment process, provided that the biological treatment is carried out on-site and the treatment sludge is incinerated [117, TWG 2 comments, 2005].



**Economics**

Economics of the applied treatment techniques

**Driving force for implementation**

Legislation, relief of the biological WWTP and sludges from heavy metal loads.

**References to literature and example plants**

[91, Serr, 2004], \*014V,I\*, \*015D,I,O,B\*, \*068B,D,I\*

### 4.3.7.23 Recovery of iodine from waste water streams

#### Description

On the \*015D,I,O,B\* site, iodine alkyl compounds are used for alkylation. Since iodine is not part of the target molecule, it remains as I<sup>-</sup> stoichiometrically in waste water streams after phase separation. Iodine is recovered from the mother liquor from the first phase separation step since this waste water stream contains the highest load.

Waste water stream	I <sup>-</sup> concentration	I <sup>-</sup> load	I <sup>-</sup> recovery?
Mother liquor	92 g/l	550 kg/batch	Yes
Wash-water 1	16 g/l	48 kg/batch	No
Wash-water 2	1.5 g/l	4.5 kg/batch	No

**Table 4.78: Examples for waste water streams containing iodine**

Iodine is recovered as CuI by pH adjustment, oxidation with NaSO<sub>3</sub>, addition of CuSO<sub>4</sub> and filtration of the precipitate.

#### Achieved environmental benefits

Recovery of valuable material for re-use/sale instead of emission to water.

#### Cross-media effects

Chemicals consumption.

#### Operational data

*No information provided.*

#### Applicability

Generally applicable.

#### Economics

*No information provided.*

#### Driving force for implementation

Recovery of valuable material.

#### References to literature and example plants

\*015D,I,O,B\*

#### 4.3.7.24 Disposal of waste water streams containing high P loads

##### Description

Waste water streams containing high phosphorus loads are segregated and disposed of separately on the \*055A,I\* site in order to relieve the biological WWTP and the receiving water from higher loads. Table 4.79 shows examples for such mother liquors.

	Total P	Volume per batch	P load per batch	H <sub>3</sub> PO <sub>4</sub> content
Mother liquor 1	130 g/l	0.5 m <sup>3</sup>	65 kg	34 % w/w
Mother liquor 2	181 g/l	1.5 m <sup>3</sup>	271.5 kg	

**Table 4.79: P containing mother liquors for disposal**

##### Achieved environmental benefits

Relief of the biological WWTP and the receiving water from high P loads.

##### Cross-media effects

*None believed likely.*

##### Operational data

*No information provided.*

##### Applicability

Generally applicable.

##### Economics

*No information provided.*

##### Driving force for implementation

Relief of the biological WWTP and receiving water.

##### References to literature and example plants

\*055A,I\*

### 4.3.8 Treatment of the total effluent and related emission levels

#### 4.3.8.1 Achievable values for heavy metals in the total effluent

##### Description

Data sampled and supplied for [31, European Commission, 2003] from Germany showed, that for typical chemical sites the following values in the total effluent (without dilution of the waste water with rain or cooling water) are achieved. Somewhat higher values for heavy metals, especially Zn, Cu and Ni, are possible in spite of adequate pretreatment in smaller installations, especially from the production of organic fine chemicals (see Table 4.80).

Parameter	Achievable emission values in mg/l			
	Cr	Cu	Ni	Zn
Intentional use of the heavy metal (applying pretreatment)	0.05	0.1	0.05	0.1

**Table 4.80: Achievable values for heavy metals in the total effluent**

The achieved values take metal removal in biological WWTPs into account only if no shift to other media occurs (e.g. from the use of waste water treatment sludge as fertilisers).

##### Achieved environmental benefits

Relief of receiving water from heavy metal loads.

##### Cross-media effects

*None believed likely.*

##### Operational data

*No information provided.*

##### Applicability

Generally applicable.

##### Economics

*No information provided.*

##### Driving force for implementation

Relief of receiving water from heavy metal loads.

##### References to literature and example plants

[50, UBA, 2001]

### 4.3.8.2 Pretreatment of the total effluent by chemical oxidation with H<sub>2</sub>O<sub>2</sub>

#### Description

\*004D,O\* is an SME and produces organic dyes (mainly azo dyes) and optical brighteners (stilbene type) in a multipurpose plant. Due to the poor biodegradability (and the intensive colour), all process waters are stored and pretreated before discharge to the municipal sewer by continuous oxidation with Fenton's reagent (H<sub>2</sub>O<sub>2</sub>/catalyst). The pretreatment is carried out in a standard stirred tank reactor.

#### Achieved environmental benefits

- chemical oxidation of biologically low degradable organic load
- COD removal of up to 95 % already before biological treatment
- it is presumed that the remaining COD is more biologically degradable.

#### Cross-media effects

- chemical consumption
- energy consumption.

#### Operational data

- throughput: 40000 m<sup>3</sup> per year (about 150 m<sup>3</sup> per day)
- input salt content: 10 %
- conditions: 110 °C and 1 bar
- COD input to pretreatment: 5000 mg/l (750 kg per day)
- COD removal by pretreatment: depends on residence time and H<sub>2</sub>O<sub>2</sub> dosage, up to 95 %, actually 80 %
- COD load after pretreatment: 38 kg per day (95 % removal)  
150 kg per day (80 % removal).

#### Applicability

- applicable where biological treatment would not lead to sufficient removal
- where the total effluent includes wash, cleaning and rinsing waters with low organic loads, pretreatment is efficient only if applied to waste water streams with high refractory loads (see also Section 4.3.7.10)
- an example for the treatment of selected waste water streams by chemical oxidation with H<sub>2</sub>O<sub>2</sub> is given in Section 4.3.7.7.

Other examples are given in Table 4.81:

Reference plant	Throughput m <sup>3</sup> /hour (max)	ppm COD input (max)	ppm COD output	Pollutants	Average H <sub>2</sub> O <sub>2</sub> consumption kg/m <sup>3</sup> related to 100 % oxidation	Investment costs in EUR	Operating costs EUR/m <sup>3</sup>
*108B,I*	8	15000	5000	Aniline, pyridine, thiophene, other toxic organic compounds	15	500000	10
*109A,V*	5	5000	1500	Non degradable compounds, organic solvents	7	500000	5
*110B*	2	5000	500	Glyphosate, other toxic organic compounds	10	450000	8
*112X*	100	3500	2500	Mercaptobenzothiazole and others	2	1900000	1.3

**Table 4.81: Examples for the application of chemical oxidation with H<sub>2</sub>O<sub>2</sub>**

### Economics

Operational costs: EUR 1 – 1.5/kg removed COD. See also Table 4.81.

### Driving force for implementation

Reduction of the COD loads. Relief of the planned municipal biological WWTP.

### References to literature and example plants

\*004D,O\*, [58, Serr, 2003], [99, D2 comments, 2005]

### 4.3.8.3 On-site instead of off-site biological WWTP

#### Description

\*016A,I\* has two pharmaceutical production sites in Sweden. Effluent waste water was previously discharged to the municipal waste water treatment plant, but investigations showed that the biological removal in the municipal plant was periodically disturbed by the \*016A,I\* effluent. Also, some organic substances were not degraded and were found in the effluent to the recipient watercourse. \*016A,I\* decided to improve the treatment and to tailor-make a process for its own waste water streams, with the aim of producing an effluent with an acceptable quality for direct discharge to the recipient watercourse.

#### Achieved environmental benefits

- replacement of low performance co-treatment by specific on-site treatment
- on-site treatment enables efficient control, management and monitoring of waste water streams from multipurpose sites and the related treatment performance, and discharges to receiving waters
- avoidance of risks arising from volatile compounds introduced with industrial effluents into the sewerage system.

#### Cross-media effects

- on-site treatment can involve adding nutrients and may require additional buffer volume for balancing flow and loads
- in individual cases difficult compounds may be degradable only below the inhibition threshold concentration (available in co-treatment).

#### Operational data

Depends on the individual case.

#### Applicability

For existing plants with existing off-site arrangements (including contracts, plant layout), the move to an on-site WWTP represents a higher obstacle.

#### Economics

*No information provided.*

#### Driving force for implementation

Avoidance of a disturbance in the municipal WWTP and consequent problems of WWTP effluent quality. Reduction of the COD releases to receiving waters.

#### References to literature and example plants

[52, Berlin, 2000], \*016A,I\*

### 4.3.8.4 Joint treatment with municipal waste water

#### Description

In a joint treatment of municipal waste water with waste water from an OFC site to a first approximation, there are neither synergistic nor antagonistic effects; i.e. the residual loadings simply can be added up. However, the joint treatment can have advantages and disadvantages (see **Achieved environmental benefits** and **Applicability**). To minimise the risks, it is essential to study carefully the waste water streams fed to the effluent treatment plant for any factors inhibiting nitrification and, if appropriate, to improve the critical partial streams by pretreatment or to feed them under metered control.

For reasons of water economy and to minimise the nitrogen emissions occurring during nitrification breakdowns, it can frequently be expedient to pretreat ammonium-polluted waste water streams physico-chemically, where appropriate in combination with ammonia recycling.

In the case of a joint waste water treatment, it must be ensured, in all cases, that the nitrogen elimination is no poorer than in the case of separate waste water treatment overall.

As a special case of the joint treatment, it has proven useful to introduce chemical waste waters in a controlled way into municipal waste water treatment plants. Examples of these are the specific metered introduction of concentrated readily degradable partial streams into the anaerobic stage (digestion tower) or into the denitrification stage.

#### Achieved environmental benefits

- improving the nutrient conditions
- optimising the waste water temperature and thus the degradation kinetics
- equalisation of the feed loadings, if the daily curves of the two waste water streams are correspondingly structured or can be matched to one another
- suppression of toxic and inhibitory effects of waste water constituents by lowering the concentrations below the critical thresholds of toxic activity.

#### Cross-media effects

*None believed likely.*

#### Operational data

Depends on the individual case.

#### Applicability

Individual assessment is required. Not applicable in the following cases:

- in municipalities that are predominantly drained by the combined sewerage system, and in the event of relatively high rainfall, hydraulic overloads can occur which lead to an increased pollutant discharge and to nitrifiers and other bacteria having a relatively long reproduction time being swept out of the joint effluent treatment plant
- reduced clean-up rates due to production-related operating faults lead, in the case of a joint treatment facility, to increased water pollution, since the municipal waste water fraction is then also inadequately treated
- many chemicals, some in low concentrations, can hinder nitrification. After a collapse of the nitrification, it can take several weeks until sufficient nitrogen elimination can again be ensured.



Joint treatment with municipal waste water is not applicable for complex effluents with lots of unknown metabolites and by-products. For these effluents, on-site biological WWTP should be preferred [99, D2 comments, 2005].

Generally, the bigger the treatment plant, the more stable the biological treatment process and the better the achievable result [117, TWG 2 comments, 2005].

### **Economics**

The joint treatment of waste water and sewage sludge can, in individual cases, give potential savings in capital and operating costs.

### **Driving force for implementation**

Cost savings.

### **References to literature and example plants**

[62, D1 comments, 2004], and many examples from the OFC sectors

#### 4.3.8.5 Proving the efficiency of off-site waste water treatment

##### Description

\*001A,I\*'s waste waters are finally treated in a municipal WWTP. Degradation/elimination is proven for relevant parameters (e.g. COD/TOC, AOX, total P) by collecting and mixing samples and carrying out degradations/elimination testing on these samples with simulation of the conditions in the municipal WWTP.

##### Achieved environmental benefits

Enables evaluation of the performance at an off-site WWTP.

##### Cross-media effects

*None believed likely.*

##### Operational data

- frequency: quarterly
- simulation of aerobic treatment: Zahn-Wellens test (see also Section 4.3.1.3).

##### Applicability

Generally applicable.

##### Economics

Additional costs for sampling and testing.

##### Driving force for implementation

Proving the performance of the off-site treatment of waste waters.

##### References to literature and example plants

\*001A,I\* (with modifications: \*007I\*, \*021B,I\*)

### 4.3.8.6 Treatment of the total effluent

#### Description

The main step for reducing the organic load of waste water is the treatment of the total effluent. Integrated measures and the pretreatment of selected waste water streams lead to a good biologically treatable total effluent. Due to the changing input from multipurpose production, the biological stage will still have to cope with the changing loads and properties (toxicity, biodegradability) of the input. Figure 4.80 shows a reliable setup to meet this challenge (typical especially within the OFC sectors), with good performance. This setup includes two biological treatment stages, activated carbon adsorption, chemical precipitation (phosphorus elimination) and sand filtering.

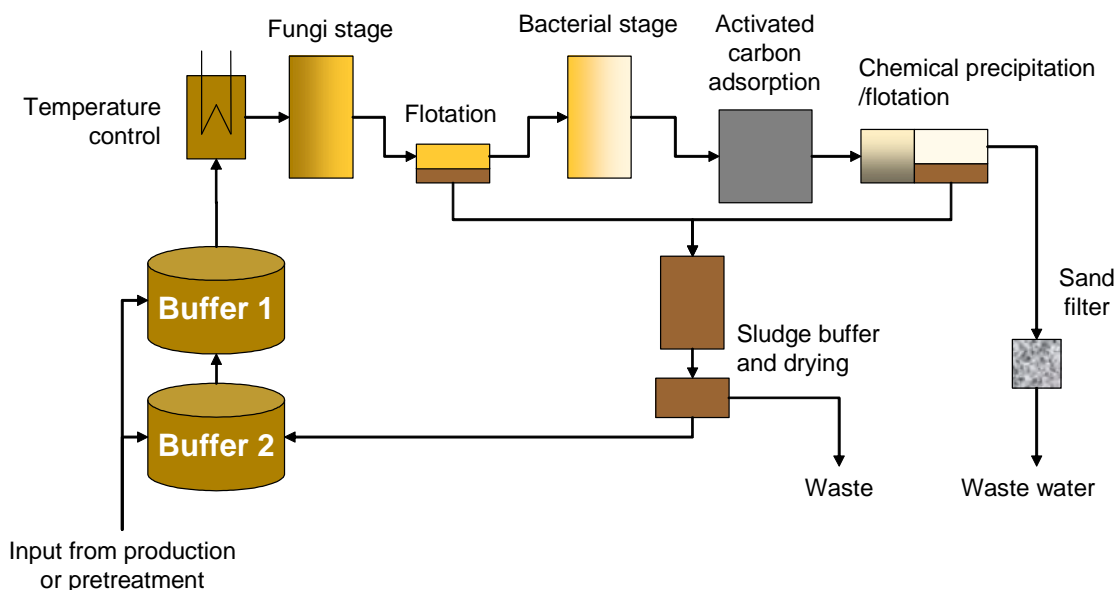

Figure 4.80: Treatment of the total effluent with two biological and one activated carbon stages

#### Achieved environmental benefits

- elimination of the organic load: 97 % (2001)
- elimination of the nitrogen: 80 %
- elimination of the phosphorus: 98.5 % (2001)
- high toxicity reduction, high stability versus toxicity shocks
- effective also for remaining low degradable substances.

#### Cross-media effects

No additional effects in comparison to other biological treatment plants. Activated carbon has to be recycled or disposed of.

#### Operational data

- capacity: 2000 m<sup>3</sup>/d
- input temperature: 29 – 30 °C
- residence period: 30 hours
- buffer volume: 2 x 4000 m<sup>3</sup>
- fungi stage: bio-film, pH 4/75 % elimination of organic load
- bacteria stage: bio-film, pH 8/90 % elimination of organic load related to input.

Pretreatment of low degradable waste water streams by adsorption before the biological stages.

### **Applicability**

When in combination with a suitable pretreatment for particular low degradable or toxic waste water streams, a wide applicability is expected.

The given example is not the only possible reliable setup. For more information, see [31, European Commission, 2003], and especially the examples described in Annexes 7.6.1 and 7.6.2 therein.

Other examples where an activated carbon adsorption is applied to the total effluent after biological treatment:

- \*009A,B,D\*
- \*082A,I\*
- \*089A,I\* as an AOX guard.

### **Economics**

*No information provided.*

### **Driving force for implementation**

Low performance of the co-treatment within a municipal WWTP.

### **References to literature and example plants**

\*016A,I\*

### 4.3.8.7 Protection and performance of biological WWTPs (1)

#### Description

It is presumed that when taking suitable measures to prevent toxic waste water streams disturbing biological degradation, average BOD<sub>5</sub> elimination rates above 99 % are achieved if full advantage is taken of the biological degradation potential in the biological WWTP. Table 4.82 shows the achievable emission values for toxicity and suspended solids.

Parameter		Achievable emission value	Unit
Suspended solids		10 – 20	mg/l
Toxicity to	Fish LID <sub>F</sub>	2	Lowest ineffective dilution <sup>1</sup>
	Daphnia LID <sub>D</sub>	4	
	Algae LID <sub>A</sub>	8	
	Luminescent bacteria LID <sub>L</sub>	16	
<sup>1</sup> For an explanation, see “LID” in the Glossary			

**Table 4.82: Achievable emission values after biological WWTP**

Protection of the biological treatment plant is assured by:

- segregation and pretreatment or disposal (incineration) of toxic waste water streams
- monitoring of the untreated waste water by, e.g. automated biological test equipment (“toximeter”), measurement of sludge activity or by controlling the characteristic parameters from sensible production processes
- provision of sufficient buffer volume to avoid input quality fluctuations in terms of organic load, nitrogen load, or salt concentrations (especially if salt concentrations above 10 g/l occur)
- provision of retention volume to separate unforeseen contaminated waste waters that might damage the biotic environment of the biological treatment plant
- applying advanced communication procedures between the production and WWTP facilities (e.g. information about unforeseen discharges from processes).

Examples for achieved emission levels for suspended solids (yearly averages):

- 014V,I     10 mg/l
- 011X     >10 mg/l
- 008A,I     10.4 mg/l
- 081A,I     17 – 20 mg/l
- 036L     20 mg/l

#### Achieved environmental benefits

- protection of the biological WWTP
- relief of the receiving water from oxygen demand, suspended solids and toxicity.

#### Cross-media effects

*None believed likely.*

### **Operational data**

Depends on the individual case.

### **Applicability**

Generally applicable.

Besides acute toxicity, other relevant aspects can be chronic toxicity, bioaccumulation and endocrine disruption. For bioaccumulation and endocrine disruption, test protocols are still under development [99, D2 comments, 2005].

### **Economics**

*No information provided.*

### **Driving force for implementation**

Protection of the biological WWTP and relief of the receiving water from oxygen demand, suspended solids and toxicity.

### **References to literature and example plants**

[50, UBA, 2001]

### 4.3.8.8 Protection and performance of biological WWTPs (2)

#### Description

\*100A,I\* is retrofitting their on-site biological WWTP in order to ensure stable performance, especially concerning the removal of nitrogen. The future system will be an A/B system. In step A, the influent will be detoxified by the removal of COD and the ammonification of organic N. In step B, the  $\text{NH}_4\text{-N}$  will be removed by nitrification/denitrification and the addition of a rapidly biodegradable C-source. Table 4.83 shows the current setup and the resulting N emission levels.

Under the current conditions, the performance is – despite buffering and pretreatment – affected:

- by the variation of the N input which is highly correlated with specific batch productions
- by toxic input.

Figure 4.81 shows the resulting emission levels for three illustrative periods:

In **period 1**, an average emission value of inorganic N of 10 – 20 mg/l was achieved with the current system. In this period, under quite stable and low loadings,  $\text{NO}_2^-$  and  $\text{NO}_3^-$  were practically absent (data not shown). The average  $\text{NH}_4\text{-N}$  concentration was 14.8 mg/l.

In **period 2**, the N loading rate had increased drastically and, as a result, an average  $\text{NH}_4\text{-N}$  concentration of 73.7 mg/l was reached for more than one month. Due to the toxicity of one or more products present in the waste water, the microbial population was not able to adapt to the higher N loading rates.

**Period 3** shows the effect of a peak of nitrogen resulting in an increase of the sludge loading rate by a factor 10 as a result of a specific production campaign. Although there can be a residual toxicity, it is not expected since rapid recovery of the system was observed.

<b>Influent</b>	2000 m <sup>3</sup> /day Total N: 20 – 120 mg/l Inorganic N: 10 % of total N		
<b>Buffer</b>	2800 m <sup>3</sup>		
<b>Neutralisation</b>			
<b>1. Clarification</b>			
<b>Trickling filters</b>	3160 m <sup>3</sup>		
<b>2. Clarification</b>			
<b>Activated sludge</b>	8000 m <sup>3</sup>		
<b>3. Clarification</b>			
<b>Sludge loading rate</b>	0.1 kg COD/kg VSS·d 6 g N/kg VSS·d		
	<b>Data from mid 2002 – mid 2004</b>		
	$\text{NH}_4\text{-N}$	$\text{NO}_3\text{-N}$	$\text{NO}_2\text{-N}$
	mg/l		
Mean	33.8	12.2	4.4
75 percentile	59.0	15.6	1.0
90 percentile	84.6	51.4	8.8

**Table 4.83: Setup and N emission levels of the current biological WWTP before retrofitting**

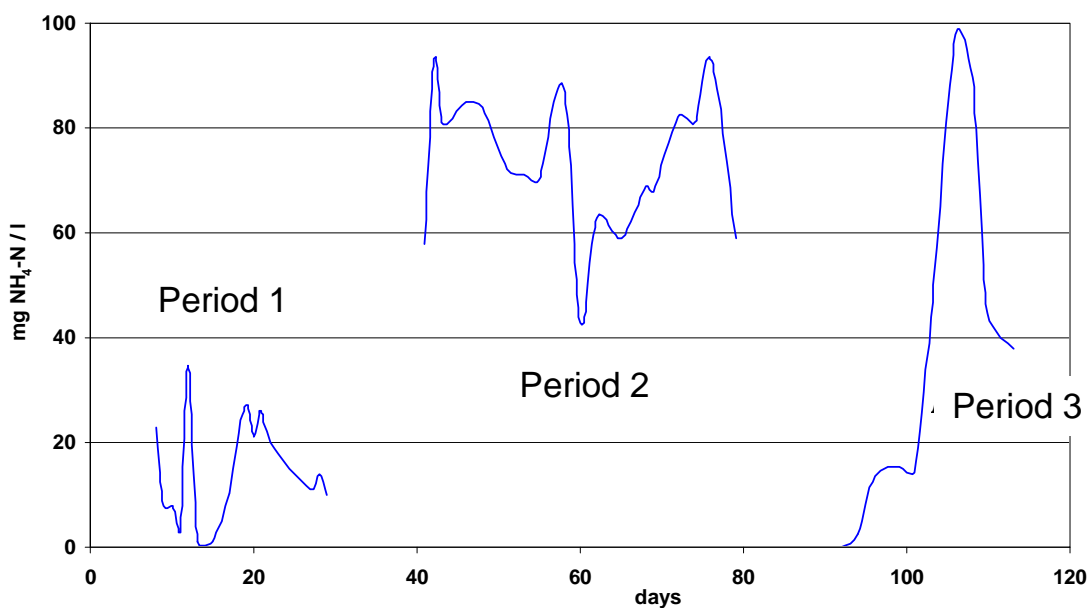

Figure 4.81: NH<sub>4</sub>-N emission levels for three selected periods from 2002 to 2004

#### Achieved environmental benefits

- stable performance of the biological WWTP
- planned after retrofitting: 10 – 20 mg/l inorganic N (mean).

#### Cross-media effects

*None believed likely.*

#### Operational data

*No information provided.*

#### Applicability

Generally applicable.

#### Economics

Costs for retrofitting.

#### Driving force for implementation

Unstable operation of the biological WWTP.

#### References to literature and example plants

\*100A,I\*



#### 4.3.8.9 COD elimination rates: waste water streams

##### Description

COD elimination rates above 95 % are achieved for waste water streams containing high refractory loadings by segregation (see also Sections 4.3.7.10, 4.3.7.11, 4.3.7.12) and subsequent pretreatment before, or instead of, treatment in the biological WWTP.

Adequate pretreatment techniques include:

- activated carbon adsorption facility (example: \*009A,B,D\*)
- high pressure wet oxidation (example: \*015D,I,O,B\*)
- low pressure wet oxidation (\*014V,I\*)
- evaporation and incineration of waste water streams (\*040A,B,I\*).

##### Achieved environmental benefits

Effective reduction of the COD releases to receiving waters.

##### Cross-media effects

Depends on the applied pretreatment technique.

##### Operational data

Depends on the applied pretreatment technique.

##### Applicability

Generally applicable.

##### Economics

*No information provided.*

##### Driving force for implementation

Reduction of the COD releases to receiving waters.

##### References to literature and example plants

[50, UBA, 2001]

### 4.3.8.10 Understanding COD emission levels and elimination rates

#### Description

The total effluent from an OFC site is usually treated on-site or off-site in a biological WWTP before release of the waste water to a receiving water body. Treatment of the total effluent with other treatment techniques is the exception (see Table 4.84).

	Alternative treatment of the total effluent	
	Applied technique	Rationale
<b>067D,I</b>	Wet oxidation	Non-degradable organic load
<b>045E</b>	Evaporation	Local meteorological conditions and low volume flow (60 m <sup>3</sup> /day) enable evaporation
<b>024A,I</b>	Incineration	Local conditions favour a very costly solution

**Table 4.84: Alternative treatment of the total effluent**

For biological WWTPs, COD elimination rates of 93 – 97 % are typically achieved as a yearly average (see Figure 4.82). It is important that a COD elimination rate cannot be understood as a standalone parameter, but has to be seen in the context of the individual situation. Some major factors with influence and their effects on the COD elimination rates are given in Table 4.85. The outliers in Figure 4.82, with elimination rates of 75 and 77 % are caused by factor (e), despite extensive segregation and pretreatment (the overall removal rate including pretreatment is much higher, see also Table 3.3).

Additionally, the operational mode (batches, campaigns, changing production spectrum) of the OFC plant creates variations. Figure 4.83, Figure 4.84 and Figure 4.85 illustrate such variations of input volume flow, organic input/output load and elimination rates. This is the reason why COD elimination rates are usually given as a yearly average.

The examples reported for the purposes of this document show COD emission levels of 12 - 390 mg/l. Figure 4.82 shows that no correlation between the output concentration and the COD elimination rate can be identified. Presuming that the biological stage is working efficiently (high BOD elimination), the remaining refractory load can only be decreased by extending segregation and pretreatment. The data set from \*017A,I\* illustrates this quite well:

- COD input: 9000 mg/l (relatively high input level)
- COD elimination: 96 % (looks quite good)
- BOD elimination: 99.6 % (also quite good).

but shows the highest emission level amongst the provided data sets (390 mg/l).

Factor		Effect	
Degree of segregation and pretreatment	(a)	Extensive segregation and elimination of poorly degradable COD prior to biological treatment	Higher elimination rates
	(b)	Less segregation and elimination of poorly degradable COD prior to biological treatment	Lower elimination rates
	(c)	Extensive removal of solvents	Lower elimination rates
	(d)	Less removal of solvents	Higher elimination rates
Production spectrum	(e)	Production spectrum causes poorly degradable COD loads in most of the waste water streams	Lower elimination rates, despite pretreatment
	(f)	Production spectrum causes poorly degradable COD loads only in several waste water streams	High elimination rates

Table 4.85: Factors with influence on COD elimination rates of biological WWTPs

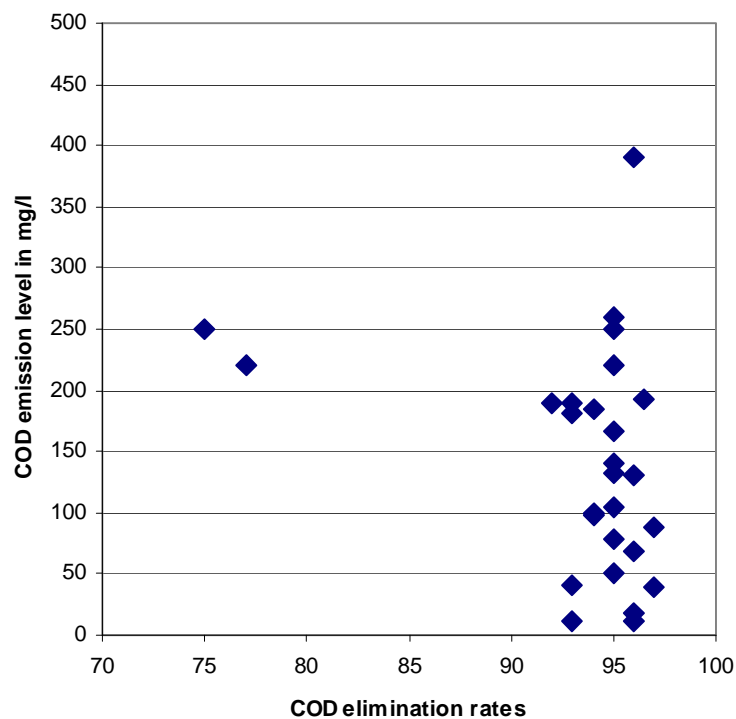
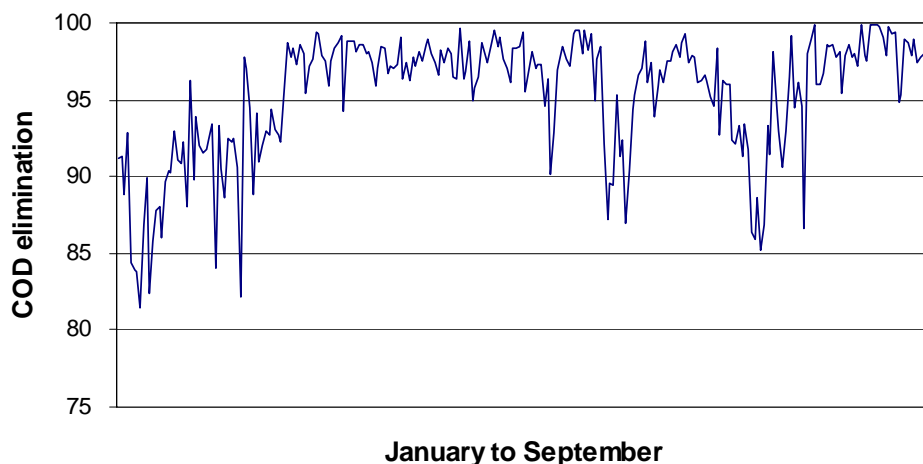
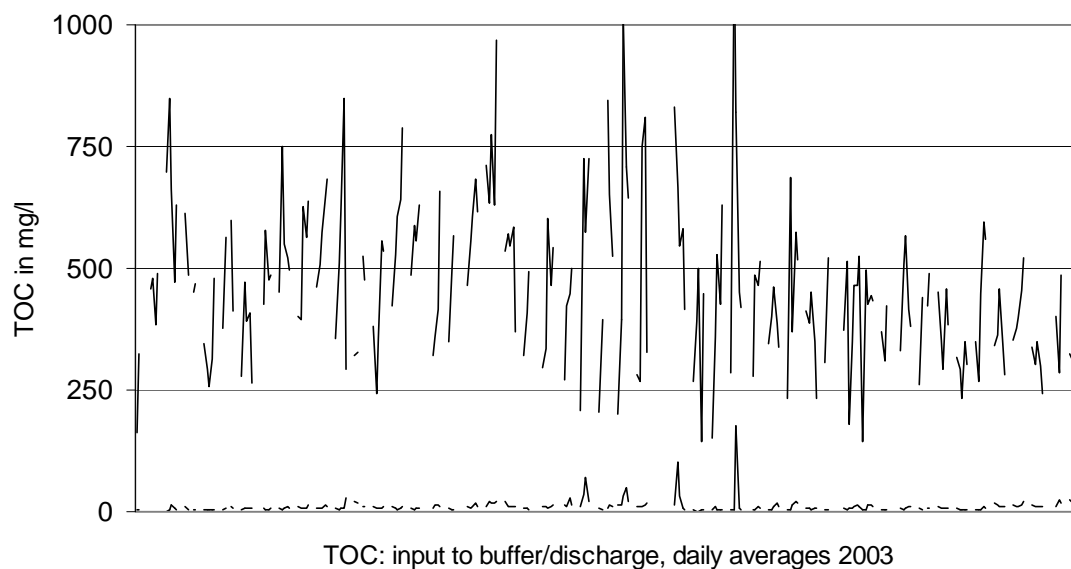

Figure 4.82: COD elimination rates and emission levels from biological WWTPs on OFC sites



**Figure 4.83: COD elimination profile for the biological treatment of a total effluent**  
 The profile is based on daily values calculated from input/output concentrations and treated volume.



**Figure 4.84: Input to and discharge from a biological WWTP on a multipurpose site**

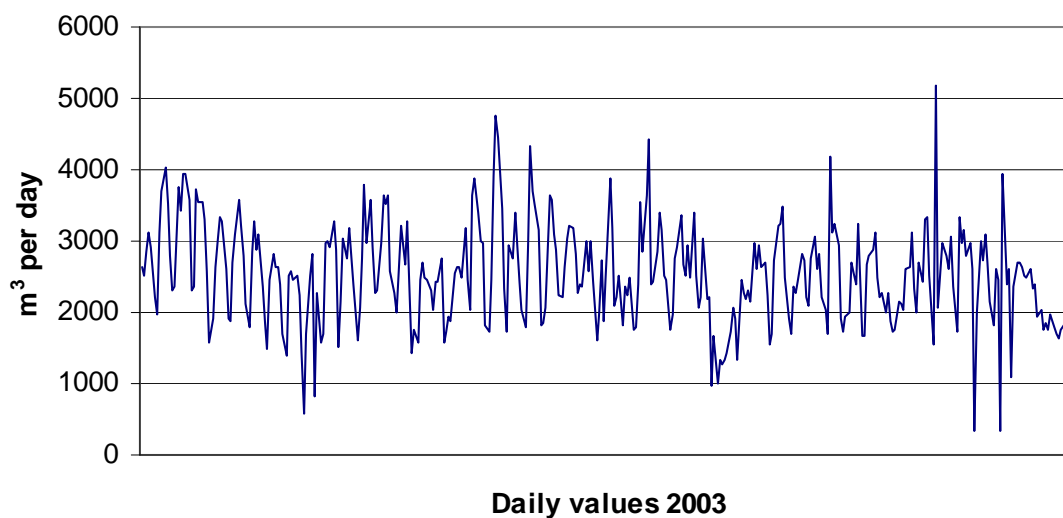

**Figure 4.85: Volume flow to the biological WWTP of \*043A,I\***

**Achieved environmental benefits**

The understanding of performance data is the basis for establishing optimisation strategies.

**Cross-media effects**

*None believed likely.*

**Operational data**

*No information provided.*

**Applicability**

Generally applicable.

**Economics**

*No information provided.*

**Driving force for implementation**

The understanding of performance data is the basis for establishing optimisation strategies.

**References to literature and example plants**

See Table 3.3 for data and reference plants.

### 4.3.8.11 BOD elimination rates and emission levels

#### Description

The total effluent from an OFC plant is usually treated finally in a biological WWTP. BOD elimination and emission levels indicate to which extent the biological degradation process of the easily degradable organic load is completed.

The data provided show BOD input levels to biological WWTPs of 370 to 3491 mg/l. Figure 4.86 shows the related BOD elimination rates and BOD emission levels. All achieved emission levels are below 20 mg/l and elimination rates range from 98.4 to 99.8 %. The lowest BOD elimination rate belongs to a low inlet concentration (370 mg/l) and one of the lowest provided BOD emission levels (6 mg/l). All levels relate to testing of the unfiltered sample.

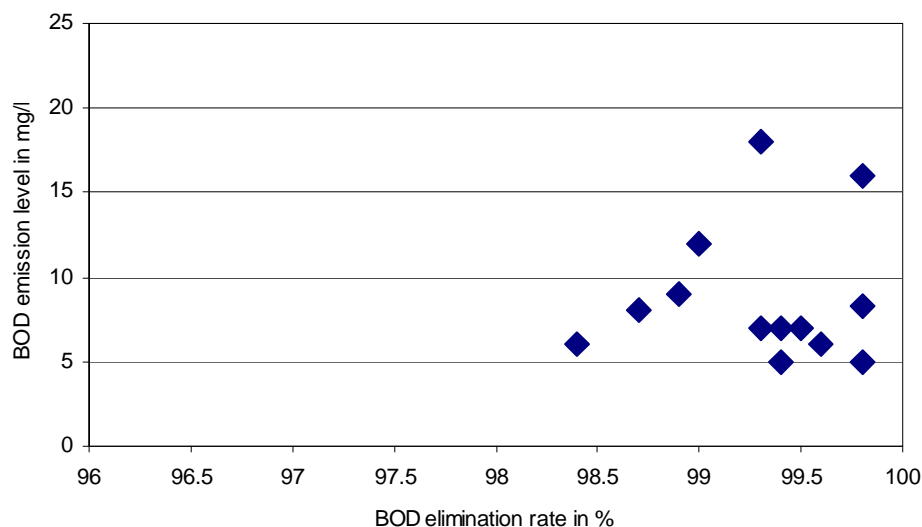

Figure 4.86: BOD elimination rates related to the achieved BOD emission level

#### Achieved environmental benefits

- completion of the easily degradable organic load relieves the receiving water body
- low BOD emission levels indicate operational stability of the biological stages.

#### Cross-media effects

*None believed likely.*

#### Operational data

*No information provided.*

#### Applicability

General applicable.

#### Economics

*No information provided.*

**Driving force for implementation**

See Achieved environmental benefits.

**References to literature and example plants**

See reference plants in Table 3.3.

## 4.3.8.12 AOX elimination rates and emission levels

## Description

The total effluent from an OFC plant is usually treated finally in a biological WWTP. AOX elimination and emission levels indicate to which extent the biological degradation process eliminated organohalogenes. The data provided show AOX elimination rates from 15 to 94 % and emission levels from 0.06 to 1.7 mg/l. Figure 4.87 shows the AOX elimination rates in relation to achieved emission levels. For input concentrations, see Section 4.3.7.14.

Taking into account that the AOX data are derived from the same reference plants, the AOX elimination rates are systematically lower in comparison to COD elimination. This reflects the assumption that halogens (amongst others) belong to the functional groups causing lower biodegradabilities [33, DECHEMA, 1995].

AOX is just another screening parameter for organic compounds, hence strategies to decrease AOX emissions are similarly based on segregation and pretreatment of waste water streams.

Example: no AOX related pretreatment is carried out in the case of \*023A,I\*, and the emission level is 5 mg/l.

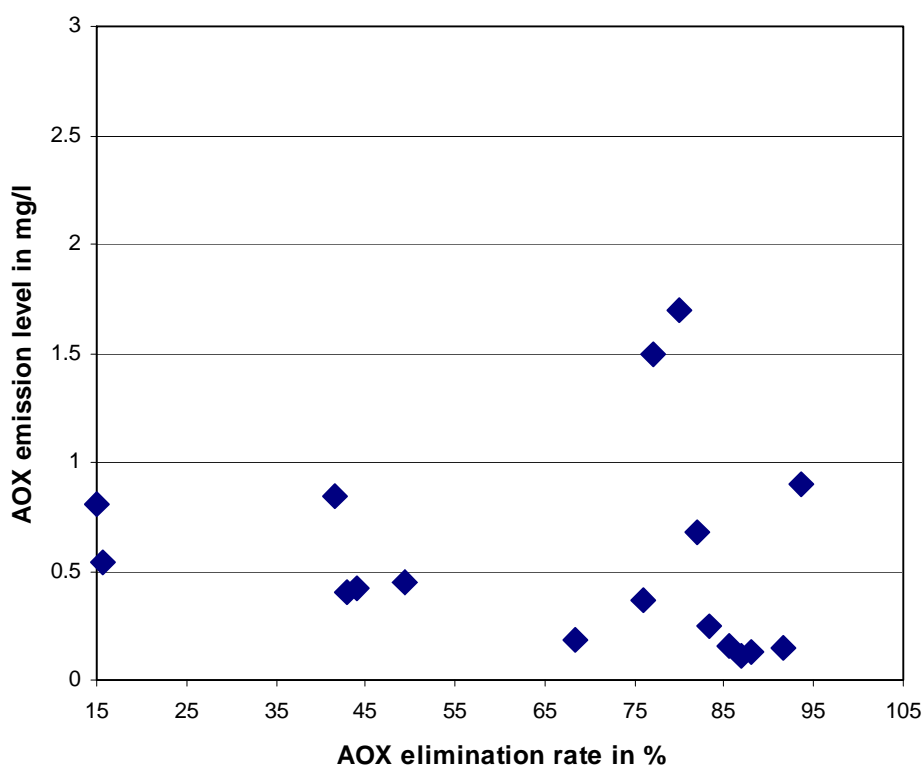

Figure 4.87: AOX elimination rates and emission levels

## Achieved environmental benefits

- relief of the receiving water body from AOX compounds
- screening parameter to develop improvement strategies.

## Cross-media effects

*None believed likely.*



**Operational data**

*No information provided.*

**Applicability**

Generally applicable.

**Economics**

*No information provided.*

**Driving force for implementation**

See Achieved environmental benefits.

**References to literature and example plants**

See reference plants in Table 3.5.

## 4.3.8.13 LID emission levels

## Description

The total effluent from an OFC plant is usually treated finally in a biological WWTP. Assessment of the effluent (WEA) shows remaining toxicity to algae, luminescent bacteria, daphnia, fish and genotoxicity. Figure 4.88 shows the LID emission levels provided (see also Table 3.5).

Increased remaining toxicity levels (expressed as LID or  $EC_{50}$ ) after biological treatment indicate improvement potential. Options include:

- extend segregation/pretreatment of waste water streams with toxic organic load
- improve buffering/equalisation of the input to the biological WWTP.

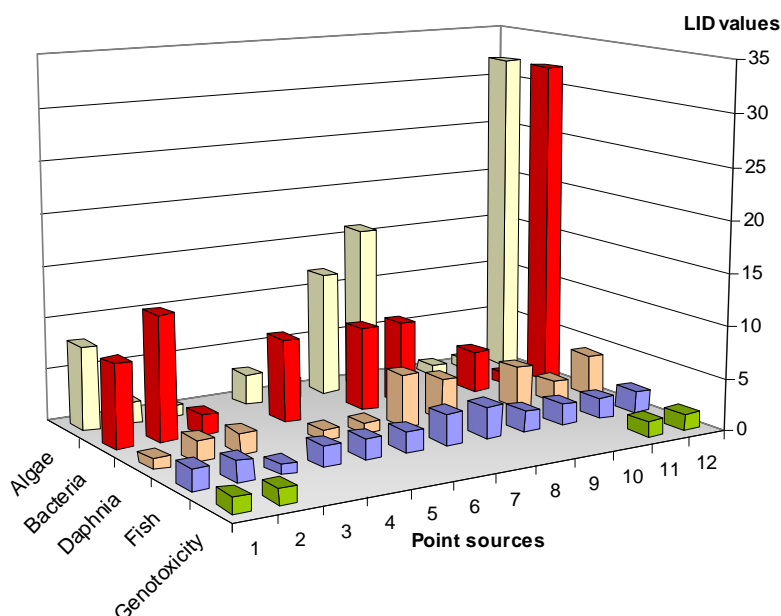

Figure 4.88: Toxicity values derived from assessment of the total effluent

## Achieved environmental benefits

- relief of the receiving water body
- indicator for improvement potential.

## Cross-media effects

*None believed likely.*

## Operational data

*No information provided.*

## Applicability

Generally applicable.

**Economics**

Costs for additional monitoring and resulting measures.

**Driving force for implementation**

See Achieved environmental benefits.

**References to literature and example plants**

See reference plants in Table 3.5.

## 4.3.8.14 Nitrogen emission levels

**Description**

The total effluent from an OFC plant is usually treated finally in a biological WWTP. Degradation of inorganic nitrogen compounds (expressed as inorganic N, as the sum of  $\text{NH}_4^+$ ,  $\text{NO}_3^-$ ,  $\text{NO}_2^-$ ) is usually carried out by nitrification and denitrification steps. Figure 4.89 shows the emission data provided, including (where available) the emission levels for total N. Levels for inorganic N range from 1 to 34 mg/l. The emission levels for total N are usually higher since also organic bound nitrogen is included in the value. The biological WWTPs releasing the highest inorganic N levels (50 and 34 mg/l) were retrofitted in 2004 in order to adjust the treatment capacity or improve performance. In one case, the high values are caused by high  $\text{NH}_4^+$  loadings from an extended fermentation unit, the other case is described in Section 4.3.8.8. The lowest values are achieved where the capacity of the WWTP allows long residence times, e.g. in the case of \*096A,I\* with an inorganic N of 1 mg/l and a residence time of seven days.

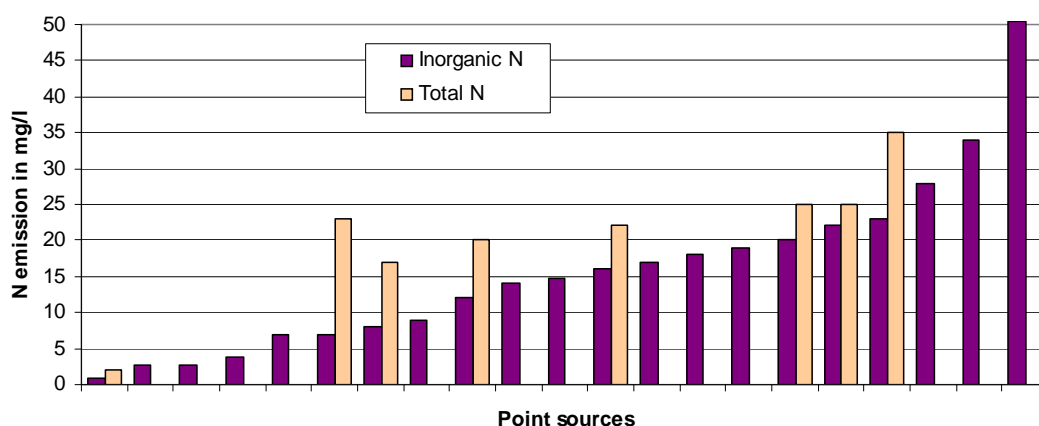

Figure 4.89: Nitrogen emission levels after biological WWTP

**Achieved environmental benefits**

Relief of the receiving water body.

**Cross-media effects**

*None believed likely.*

**Operational data**

*No information provided.*

**Applicability**

Generally applicable.

**Economics**

*No information provided.*

**Driving force for implementation**

Reduction of inorganic nitrogen compound releases to receiving waters.

**References to literature and example plants**

See reference plants in Table 3.4.

#### 4.3.8.15 Elimination of inorganic nitrogen from waste waters

##### **Description**

Yearly average emission values for inorganic nitrogen from 10 to 20 mg/l are achievable by nitrification/denitrification within a biological WWTP.

##### **Achieved environmental benefits**

Effective reduction of inorganic nitrogen compound releases to receiving waters.

##### **Cross-media effects**

Energy consumption for the operation of the additional treatment stage.

##### **Operational data**

Sufficient residence times are required to ensure an optimised degradation.

##### **Applicability**

Generally applicable.

##### **Economics**

*No information provided.*

##### **Driving force for implementation**

Reduction of inorganic nitrogen compound releases to receiving waters.

##### **References to literature and example plants**

[50, UBA, 2001], [31, European Commission, 2003]

**4.3.8.16 Elimination of phosphorus compounds from waste waters****Description**

Yearly average emission values for total P from 1 – 1.5 mg/l are achievable by biological elimination and, where required, chemical/mechanical treatment within a biological WWTP.

**Achieved environmental benefits**

Effective removal of phosphorus compound releases to receiving waters.

**Cross-media effects**

*None believed likely.*

**Operational data**

*No information provided.*

**Applicability**

Generally applicable.

**Economics**

*No information provided.*

**Driving force for implementation**

Reduction of phosphorus compound releases to receiving waters.

**References to literature and example plants**

*No information provided.*

### 4.3.8.17 Phosphorus emission levels

#### Description

The total effluent from an OFC plant is usually treated finally in a biological WWTP. Phosphorus compounds are partially consumed as a nutrient in the biological stage and the remaining share is removed by means of chemical/mechanical treatment before discharge. Figure 4.90 shows the provided input/output levels to biological WWTPs on OFC sites.

Input levels range from 3.5 to 48 mg/l and emission levels (in cases where chemical/mechanical treatment is applied) from 0.2 to 1.5 mg/l. In the case of \*086A,I\*, no chemical/mechanical step is applied for specific P removal with a resulting emission level of 10.8 mg/l.

These are the examples with higher emission levels:

- \*011X\*: optimisation of the biological stage resulted in lower P emission levels (2000: 1.5 mg/l; 2003: 0.5 mg/l)
- \*047B\*: despite efforts to optimise the biological stage, P emission levels remain at 1.3 mg/l. The background to this is the production of P-organic compounds.

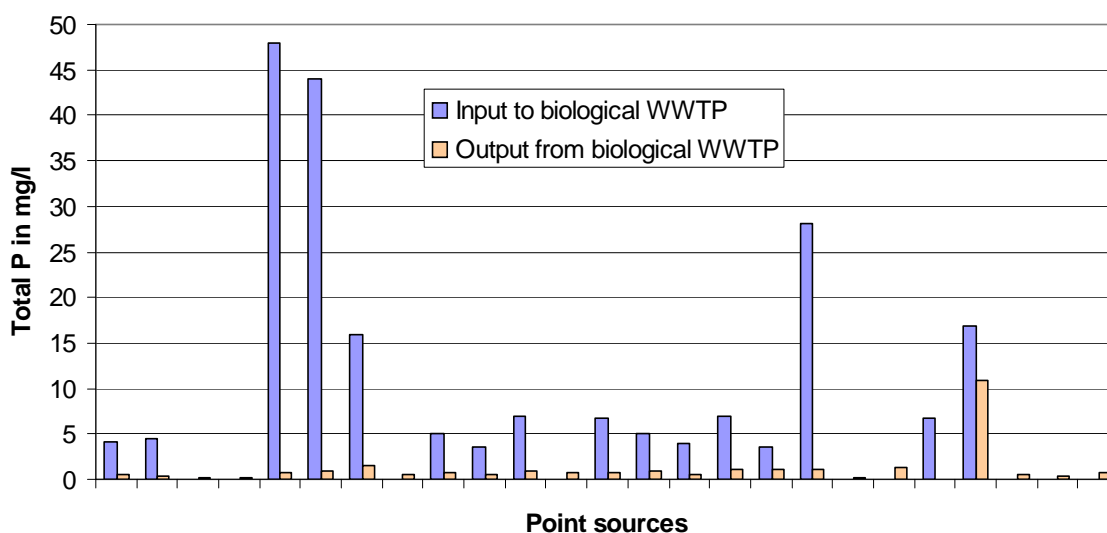

Figure 4.90: Total P input and output levels to/from biological WWTPs on OFC sites

#### Achieved environmental benefits

Relief of the receiving water body.

#### Cross-media effects

*None believed likely.*

#### Operational data, Applicability

*No information provided.*



**Economics**

Generally applicable.

**Driving force for implementation**

Reduction of phosphorus compound releases to receiving waters.

**References to literature and example plants**

See reference plants in Table 3.4

## 4.3.8.18 Biomonitoring of effluents from active ingredient production

## Description

On the \*040A,B,I\* site, APIs and biocides are produced. Biomonitoring (toxicity to fish, daphnia, algae and luminescent bacteria expressed as LID values) has been used to assess residual acute toxicity in the effluent remaining after the biological WWTP (see also Section 4.3.8.13). Experience of some years show:

- generally, the information derived from the four different test species complement each other
- even at a larger complex production site it is technically possible to identify the cause of residual acute toxicity and to minimise the effects
- the sampling frequency should correspond to the frequency of changes in the production spectrum (in the given example, 20 samples were tested per year).

Figure 4.91 shows the results of biomonitoring from 1985 to 1996 in the case of \*040A,B,I\*. Step by step, the plant realised the segregation and disposal of critical waste water streams (incineration) and improvement of specific production steps. Finally, the following average LID values were achieved:

- LID<sub>F</sub>: 1
- LID<sub>D</sub>: 2
- LID<sub>L</sub>: 3
- LID<sub>A</sub>: 1.

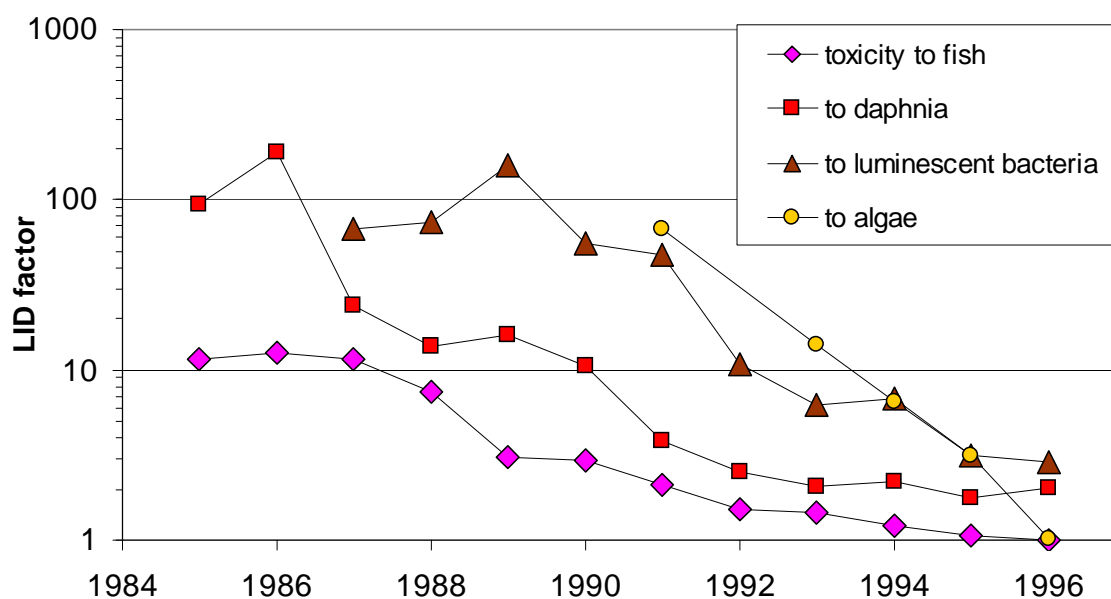

Figure 4.91: Average residual acute toxicity in the effluent of \*040A,B,I\*  
Each yearly value is based on 20 measurements

## Achieved environmental benefits

Biomonitoring data represent a valuable tool for the assessment of residual acute toxicity and of complex effluents.

**Cross-media effects**

*None believed likely.*

**Operational data**

The monitoring frequency should match with the changes in the production spectrum.

**Applicability**

Especially applicable where other parameters indicate variations in the performance of the biological WWTP or where toxicity is already identified as a major concern due to the production spectrum (e.g. biologically active ingredients).

Generally applicable to identify situations where a production site has an inherent toxicity problem which is not easily identified by the observation of other parameters.

**Economics**

- costs for sampling and measurements
- high value of the obtained information.

**Driving force for implementation**

Residual acute toxicity in effluents from the production of active ingredients.

**References to literature and example plants**

[88, Falcke, 1997], \*040A,B,I\*

### 4.3.8.19 WEA as a management tool for treatment of waste water streams

#### Description

The effectiveness of the treatment of waste water streams can be evaluated with WEA (whole effluent assessment) (see also Section 2.4.2.4). The assessment of ecotoxicological aspects – comprising toxicity, persistency and bioaccumulation – with bioassays is performed on the treated waste water streams or on the total effluent to examine the effect on the environment. When the impact on the environment is judged as significant, treatment of waste water streams should be improved. Changes in the treatment of waste water are evaluated on their environmental performance.

#### Achieved environmental benefits

Less adverse effects on the aquatic environment.

#### Cross-media effects

Depends on the pretreatment technique.

#### Operational data

Effluents from pretreatment facilities can be sampled and evaluated. The gathered information can be used as a management tool to reduce the impact on the environment.

#### Applicability

Especially applicable where other parameters indicate variations in the performance of the biological WWTP or where toxicity is already identified as a major concern due to the production spectrum (e.g. biologically active ingredients).

Generally applicable to identify situations where a production site has an inherent toxicity problem which is not easily identified by the observation of other parameters.

Several tests within the WEA toolbox are available and robust, mostly with regard to acute toxicity and bioaccumulation. However, some further work is required on persistence and chronic toxicity, but is expected to be finalised in the next couple of years.

#### Economics

The effort required to perform tests in WEA is comparable with a comprehensive analysis of single substances in a complex effluent.

#### Driving force for implementation

Relief of the receiving water body.

#### References to literature and example plants

[99, D2 comments, 2005], [73, Gartiser, 2003]

### 4.3.8.20 Online monitoring of toxicity and TOC

#### Description

Due to the changing input from multipurpose production, the biological stage of a WWTP has to cope with the changing loads and properties of the input, e.g. toxicity. Toxic input to a biological WWTP can inhibit the degradation process and jeopardise the stable operation.

Online monitoring of toxicity measures the respiration inhibition of micro-organisms (e.g. nitrifying bacteria) when exposed to the effluent from the biological WWTP in comparison to a reference sample (see Figure 4.92). Increasing inhibition (20 – 30 % and higher) leads to corrective measures, such as:

- additional dosing of activated carbon
- recycling of the effluent to the buffer tanks.

In combination with data from online TOC measurements, it may also be possible to relate the inhibition effect to the responsible production process.

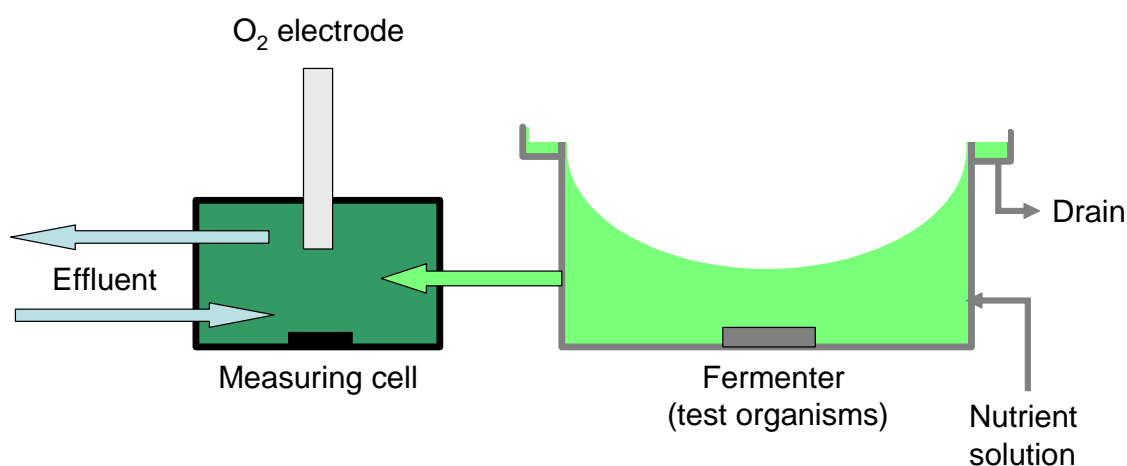

Figure 4.92: Principle of online toxicity monitoring

#### Achieved environmental benefits

Tool to protect and control an on-site biological WWTP if residual acute toxicity is identified as a concern.

#### Cross-media effects

*None believed likely.*

#### Operational data

- response times <3 minutes
- representative measurement if the nitrifying bacteria of the on-site biological WWTP are used as test organisms
- ratio of waste water to test organisms is adjustable.

### Applicability

Generally applicable.

Similar setup:

- \*009A,B,D\*: online toxicity (input to buffer) and DOC measurement
- \*010A,B,D,I,X\*: online toxicity (input to buffer) and online TOC measurement.

### Economics

- investment: EUR 40000 – 50000
- operation: EUR 4000 – 5000 per year.

### Driving force for implementation

Protection of the biological WWTP if residual acute toxicity is identified as a concern.

### References to literature and example plants

[91, Serr, 2004], \*016A,I\*

#### 4.3.8.21 Monitoring of the total effluent before and after biological treatment

##### Description

Data obtained by structured monitoring can form an important information basis for decision making on chemical sites, especially when new processes are introduced or when problems arise. Long term tendencies can be identified, as well as the effects of single events such as special production campaigns (e.g. trials), introduction of new feedstocks or the replacement of equipment.

Additionally own monitoring data can demonstrate compliance with ELVs and create a confidence climate.

Table 4.86 shows the waste water monitoring plan as established in the reference plants.

##### Achieved environmental benefits

Important data basis for decision making.

##### Cross-media effects

*None believed likely.*

##### Operational data

- measurements are omitted if a parameter is not expected to occur in the waste water either not at all or below detection limits
- lower frequencies are implemented if a parameter can be calculated reliably from the material input.

##### Applicability

Generally applicable.

##### Economics

- costs for sampling and measurements
- high value of the obtained information.

##### Driving force for implementation

Establishment of a database for decision making and for the demonstration of compliance.

##### References to literature and example plants

\*001A,I\*, \*014V,I\*, \*015D,I,O,B\*

Monitoring of	Parameters	Frequency
Input and output to pretreatment units (performance)	Relevant parameters	Daily/batch wise
<b>Biological WWTP</b>		
Input	Volume pH	Continuously Continuously
Input and output to bioreactor (e.g. anaerobic stage, pressure biology)	COD or TOC	Daily
Input to biological stage	COD or TOC	Daily
	NH <sub>4</sub> -N	Daily
	Total P	Daily
Aeration tank	Oxygen content	Continuously
	pH	Continuously
	Temperature	Continuously
	Sludge index	Daily
	NO <sub>3</sub> -N after denitrification	Daily
Clarifier stage	Visibility	Daily
<b>Sampling point before release to sewer or receiving water</b>		
	pH	Continuously
	Temperature	Continuously
	Suspended solids	Daily
	BOD <sub>5</sub>	Weekly
	COD or TOC	Daily
	NH <sub>4</sub> -N	Twice per week
	NO <sub>3</sub> -N	Twice per week
	NO <sub>2</sub> -N	Twice per week
	Cr <sup>VI</sup>	Twice per week
	Cl <sub>2</sub>	Twice per week
	CN <sup>-</sup>	Twice per week
	Total P	Monthly
	F	Monthly
	SO <sub>4</sub> <sup>2-</sup>	Monthly
	S <sup>2-</sup>	Monthly
	SO <sub>3</sub> <sup>2-</sup>	Monthly
	Al <sup>3+</sup>	Monthly
	As	Monthly
	Heavy metals	Bimonthly
	AOX	Bimonthly
	Listed substances	Bimonthly
<b>Inspection of the discharge point to the receiving water</b>		
Distinctive features such as, e.g. odour, colour, build-up of sludge		Monthly
<ul style="list-style-type: none"> <li>• measurements are omitted if a parameter is not expected to occur in the waste water at all</li> <li>• lower frequencies are implemented if a parameter can be calculated reliably from the material input</li> </ul>		

Table 4.86: Monitoring plan performed in the reference plants



## 4.4 Environmental management tools

### Description

The best environmental performance is usually achieved by the installation of the best technology and its operation in the most effective and efficient manner. This is recognised by the IPPC Directive definition of ‘techniques’ as “*both the technology used and the way in which the installation is designed, built, maintained, operated and decommissioned*”.

For IPPC installations an Environmental Management System (EMS) is a tool that operators can use to address these design, construction, maintenance, operation and decommissioning issues in a systematic, demonstrable way. An EMS includes the organisational structure, responsibilities, practices, procedures, processes and resources for developing, implementing, maintaining, reviewing and monitoring the environmental policy. Environmental Management Systems are most effective and efficient where they form an inherent part of the overall management and operation of an installation.

Within the European Union, many organisations have decided on a voluntary basis to implement environmental management systems based on EN ISO 14001:1996 or the EU Eco-management and audit scheme EMAS. EMAS includes the management system requirements of EN ISO 14001, but places additional emphasis on legal compliance, environmental performance and employee involvement; it also requires external verification of the management system and validation of a public environmental statement (in EN ISO 14001 self-declaration is an alternative to external verification). There are also many organisations that have decided to put in place non-standardised EMSs.

While both standardised systems (EN ISO 14001:1996 and EMAS) and non-standardised (“customised”) systems in principle take the *organisation* as the entity, this document takes a more narrow approach, not including all activities of the organisation e.g. with regard to their products and services, due to the fact that the regulated entity under the IPPC Directive is the *installation* (as defined in Article 2).

An environmental management system (EMS) for an IPPC installation can contain the following components:

- (a) definition of an environmental policy
- (b) planning and establishing objectives and targets
- (c) implementation and operation of procedures
- (d) checking and corrective action
- (e) management review
- (f) preparation of a regular environmental statement
- (g) validation by certification body or external EMS verifier
- (h) design considerations for end-of-life plant decommissioning
- (i) development of cleaner technologies
- (j) benchmarking.

These features are explained in somewhat greater detail below. For detailed information on components (a) to (g), which are all included in EMAS, the reader is referred to the reference literature indicated below.

### (a) Definition of an environmental policy

Top management are responsible for defining an environmental policy for an installation and ensuring that it:

- is appropriate to the nature, scale and environmental impacts of the activities
- includes a commitment to pollution prevention and control
- includes a commitment to comply with all relevant applicable environmental legislation and regulations, and with other requirements to which the organisation subscribes
- provides the framework for setting and reviewing environmental objectives and targets
- is documented and communicated to all employees
- is available to the public and all interested parties.

### (b) Planning, i.e.:

- procedures to identify the environmental aspects of the installation, in order to determine those activities which have or can have significant impacts on the environment, and to keep this information up-to-date
- procedures to identify and have access to legal and other requirements to which the organisation subscribes and that are applicable to the environmental aspects of its activities
- establishing and reviewing documented environmental objectives and targets, taking into consideration the legal and other requirements and the views of interested parties
- establishing and regularly updating an environmental management programme, including designation of responsibility for achieving objectives and targets at each relevant function and level as well as the means and timeframe by which they are to be achieved.

### (c) Implementation and operation of procedures

It is important to have systems in place to ensure that procedures are known, understood and complied with, therefore effective environmental management includes:

#### (i) Structure and responsibility

- defining, documenting and communicating roles, responsibilities and authorities, which includes appointing one specific management representative
- providing resources essential to the implementation and control of the environmental management system, including human resources and specialised skills, technology and financial resources.

#### (ii) Training, awareness and competence

- identifying training needs to ensure that all personnel whose work may significantly affect the environmental impacts of the activity have received appropriate training.

#### (iii) Communication

- establishing and maintaining procedures for internal communication between the various levels and functions of the installation, as well as procedures that foster a dialogue with external interested parties and procedures for receiving, documenting and, where reasonable, responding to relevant communication from external interested parties.

#### (iv) Employee involvement

- involving employees in the process aimed at achieving a high level of environmental performance by applying appropriate forms of participation such as the suggestion-book system or project-based group works or environmental committees.

- (v) Documentation
    - establishing and maintaining up-to-date information, in paper or electronic form, to describe the core elements of the management system and their interaction and to provide direction to related documentation.
  - (vi) Efficient process control
    - adequate control of processes under all modes of operation, i.e. preparation, start-up, routine operation, shutdown and abnormal conditions
    - identifying the key performance indicators and methods for measuring and controlling these parameters (e.g. flow, pressure, temperature, composition and quantity)
    - documenting and analysing abnormal operating conditions to identify the root causes and then addressing these to ensure that events do not recur (this can be facilitated by a ‘no-blame’ culture where the identification of causes is more important than apportioning blame to individuals).
  - (vii) Maintenance programme
    - establishing a structured programme for maintenance based on technical descriptions of the equipment, norms etc. as well as any equipment failures and consequences
    - supporting the maintenance programme by appropriate record keeping systems and diagnostic testing
    - clearly allocating responsibility for the planning and execution of maintenance.
  - (viii) Emergency preparedness and response
    - establishing and maintaining procedures to identify the potential for and response to accidents and emergency situations, and for preventing and mitigating the environmental impacts that may be associated with them.
- (d) Checking and corrective action, i.e.:
- (i) Monitoring and measurement
    - establishing and maintaining documented procedures to monitor and measure, on a regular basis, the key characteristics of operations and activities that can have a significant impact on the environment, including the recording of information for tracking performance, relevant operational controls and conformance with the installation's environmental objectives and targets (*see also the Reference document on Monitoring of Emissions*)
    - establishing and maintaining a documented procedure for periodically evaluating compliance with relevant environmental legislation and regulations.
  - (ii) Corrective and preventive action
    - establishing and maintaining procedures for defining responsibility and authority for handling and investigating non-conformance with permit conditions, other legal requirements as well as objectives and targets, taking action to mitigate any impacts caused and for initiating and completing corrective and preventive action that are appropriate to the magnitude of the problem and commensurate with the environmental impact encountered.
  - (iii) Records
    - establishing and maintaining procedures for the identification, maintenance and disposition of legible, identifiable and traceable environmental records, including training records and the results of audits and reviews.

(iv) Audit

- establishing and maintaining (a) programme(s) and procedures for periodic environmental management system audits that include discussions with personnel, inspection of operating conditions and equipment and reviewing of records and documentation and that results in a written report, to be carried out impartially and objectively by employees (internal audits) or external parties (external audits), covering the audit scope, frequency and methodologies, as well as the responsibilities and requirements for conducting audits and reporting results, in order to determine whether or not the environmental management system conforms to planned arrangements and has been properly implemented and maintained
- completing the audit or audit cycle, as appropriate, at intervals of no longer than three years, depending on the nature, scale and complexity of the activities, the significance of associated environmental impacts, the importance and urgency of the problems detected by previous audits and the history of environmental problems – more complex activities with a more significant environmental impact are audited more frequently
- having appropriate mechanisms in place to ensure that the audit results are followed up.

(v) Periodic evaluation of legal compliance

- reviewing compliance with the applicable environmental legislation and the conditions of the environmental permit(s) held by the installation
- documentation of the evaluation.

(e) Management review, i.e.:

- reviewing, by top management, at intervals that it determines, the environmental management system, to ensure its continuing suitability, adequacy and effectiveness
- ensuring that the necessary information is collected to allow management to carry out this evaluation
- documentation of the review.

(f) Preparation of a regular environmental statement:

- preparing an environmental statement that pays particular attention to the results achieved by the installation against its environmental objectives and targets. It is regularly produced – from once a year to less frequently depending on the significance of emissions, waste generation etc. It considers the information needs of relevant interested parties and it is publicly available (e.g. in electronic publications, libraries etc.).

When producing a statement, the operator may use relevant existing environmental performance indicators, making sure that the indicators chosen:

- i. give an accurate appraisal of the installation's performance
- ii. are understandable and unambiguous
- iii. allow for year on year comparison to assess the development of the environmental performance of the installation
- iv. allow for comparison with sector, national or regional benchmarks as appropriate
- v. allow for comparison with regulatory requirements as appropriate.

(g) Validation by certification body or external EMS verifier:

- having the management system, audit procedure and environmental statement examined and validated by an accredited certification body or an external EMS verifier can, if carried out properly, enhance the credibility of the system.

---

(h) Design considerations for end-of-life plant decommissioning

- giving consideration to the environmental impact from the eventual decommissioning of the unit at the stage of designing a new plant, as forethought makes decommissioning easier, cleaner and cheaper
- decommissioning poses environmental risks for the contamination of land (and groundwater) and generates large quantities of solid waste. Preventive techniques are process-specific but general considerations may include:
  - i. avoiding underground structures
  - ii. incorporating features that facilitate dismantling
  - iii. choosing surface finishes that are easily decontaminated
  - iv. using an equipment configuration that minimises trapped chemicals and facilitates drain-down or washing
  - v. designing flexible, self-contained units that enable phased closure
  - vi. using biodegradable and recyclable materials where possible.

(i) Development of cleaner technologies:

- environmental protection should be an inherent feature of any process design activities carried out by the operator, since techniques incorporated at the earliest possible design stage are both more effective and cheaper. Giving consideration to the development of cleaner technologies can for instance occur through R&D activities or studies. As an alternative to internal activities, arrangements can be made to keep abreast with – and where appropriate – commission work by other operators or research institutes active in the relevant field.

(j) Benchmarking, i.e.:

- carrying out systematic and regular comparisons with sector, national or regional benchmarks, including for energy efficiency and energy conservation activities, choice of input materials, emissions to air and discharges to water (using for example the European Pollutant Emission Register, EPER), consumption of water and generation of waste.

### **Standardised and non-standardised EMSs**

An EMS can take the form of a standardised or non-standardised (“customised”) system. Implementation and adherence to an internationally accepted standardised system such as EN ISO 14001:1996 can give higher credibility to the EMS, especially when subject to a properly performed external verification. EMAS provides additional credibility due to the interaction with the public through the environmental statement and the mechanism to ensure compliance with the applicable environmental legislation. However, non-standardised systems can in principle be equally effective provided that they are properly designed and implemented.

### **Achieved environmental benefits**

Implementation of and adherence to an EMS focuses the attention of the operator on the environmental performance of the installation. In particular, the maintenance of and compliance with clear operating procedures for both normal and abnormal situations and the associated lines of responsibility should ensure that the installation’s permit conditions and other environmental targets and objectives are met at all times.

Environmental management systems typically ensure the continuous improvement of the environmental performance of the installation. The poorer the starting point is, the more significant short-term improvements can be expected. If the installation already has a good overall environmental performance, the system helps the operator to maintain the high performance level.

### Cross-media effects

Environmental management techniques are designed to address the overall environmental impact, which is consistent with the integrated approach of the IPPC Directive.

### Operational data

No specific information reported.

### Applicability

The components described above can typically be applied to all IPPC installations. The scope (e.g. level of detail) and nature of the EMS (e.g. standardised or non-standardised) will generally be related to the nature, scale and complexity of the installation, and the range of environmental impacts it may have.

### Economics

It is difficult to accurately determine the costs and economic benefits of introducing and maintaining a good EMS. A number of studies are presented below. However, these are just examples and their results are not entirely coherent. They might not be representative for all sectors across the EU and should thus be treated with caution.

A Swedish study carried out in 1999 surveyed all 360 ISO-certified and EMAS-registered companies in Sweden. With a response rate of 50 %, it concluded among other things that:

- the expenses for introducing and operating EMS are high but not unreasonably so, save in the case of very small companies. Expenses are expected to decrease in the future
- a higher degree of co-ordination and integration of EMS with other management systems is seen as a possible way to decrease costs
- half of all the environmental objectives and targets give payback within one year through cost savings and/or increased revenue
- the largest cost savings were made through decreased expenditure on energy, waste treatment and raw materials
- most of the companies think that their position on the market has been strengthened through the EMS. One-third of the companies report increasing revenue due to EMS.

In some Member States reduced supervision fees are charged if the installation has a certification.

A number of studies<sup>1</sup> show that there is an inverse relationship between company size and the cost of implementing an EMS. A similar inverse relationship exists for the payback period of invested capital. Both elements imply a less favourable cost-benefit relationship for implementing an EMS in SMEs compared to larger companies.

According to a Swiss study, the average cost for building and operating ISO 14001 can vary:

- for a company with between 1 and 49 employees: EUR 44000 (CHF 64000) for building the EMS and EUR 11000 (CHF 16000) per year for operating it
- for an industrial site with more than 250 employees: EUR 252000 (CHF 367000) for building the EMS and EUR 106000 (CHF 155000) per year for operating it.

---

<sup>1</sup> E.g. Dyllick and Hamschmidt (2000, 73) quoted in Klemisch H. and R. Holger, *Umweltmanagementsysteme in kleinen und mittleren Unternehmen – Befunde bisheriger Umsetzung*, KNI Papers 01/02, January 2002, p 15; Clausen J., M. Keil and M. Jungwirth, *The State of EMAS in the EU. Eco-Management as a Tool for Sustainable Development – Literature Study*, Institute for Ecological Economy Research (Berlin) and Ecologic – Institute for International and European Environmental Policy (Berlin), 2002, p 15.

These average figures do not necessarily represent the actual cost for a given industrial site because this cost is also highly dependent on the number of significant items (pollutants, energy consumption, ...) and on the complexity of the problems to be studied.

A recent German study (Schaltegger, Stefan and Wagner, Marcus, *Umweltmanagement in deutschen Unternehmen - der aktuelle Stand der Praxis*, February 2002, p. 106) shows the following costs for EMAS for different branches. It can be noted that these figures are much lower than those of the Swiss study quoted above. This is a confirmation of the difficulty to determine the costs of an EMS.

Costs for building (EUR):

minimum - 18750  
 maximum - 75000  
 average - 50000

Costs for validation (EUR):

minimum - 5000  
 maximum - 12500  
 average - 6000

A study by the German Institute of Entrepreneurs (Unternehmerinstitut/Arbeitsgemeinschaft Selbständiger Unternehmer UNI/ASU, 1997, *Umweltmanagementbefragung - Öko-Audit in der mittelständischen Praxis - Evaluierung und Ansätze für eine Effizienzsteigerung von Umweltmanagementsystemen in der Praxis*, Bonn.) gives information about the average savings achieved for EMAS per year and the average payback time. For example, for implementation costs of EUR 80000 they found average savings of EUR 50000 per year, corresponding to a payback time of about one and a half years.

External costs relating to verification of the system can be estimated from guidance issued by the International Accreditation Forum (<http://www.iaf.nu>).

### **Driving forces for implementation**

Environmental management systems can provide a number of advantages, for example:

- improved insight into the environmental aspects of the company
- improved basis for decision-making
- improved motivation of personnel
- additional opportunities for operational cost reduction and product quality improvement
- improved environmental performance
- improved company image
- reduced liability, insurance and non-compliance costs
- increased attractiveness for employees, customers and investors
- increased trust of regulators, which could lead to reduced regulatory oversight
- improved relationship with environmental groups.

### **Example plants**

The features described under (a) to (e) above are elements of EN ISO 14001:1996 and the European Community Eco-Management and Audit Scheme (EMAS), whereas the features (f) and (g) are specific to EMAS. These two standardised systems are applied in a number of IPPC installations. As an example, 357 organisations within the EU chemical and chemical products industry (NACE code 24) were EMAS registered in July 2002, most of which operate IPPC installations.

In the UK, the Environment Agency of England and Wales carried out a survey among IPC (the precursor to IPPC) regulated installations in 2001. It showed that 32 % of respondents were certified to ISO 14001 (corresponding to 21 % of all IPC installations) and 7 % were EMAS registered. All cement works in the UK (around 20) are certified to ISO 14001 and the majority are EMAS registered. In Ireland, where the establishment of an EMS (not necessarily of a standardised nature) is required in IPC licenses, an estimated 100 out of approximately 500 licensed installations have established an EMS according to ISO 14001, with the other 400 installations having opted for a non-standardised EMS.

[43, Chimia, 2000] reports the following example of the successful implementation of an EMS on an OFC site:

Various production processes on the \*039A,I\* site generate large quantities of waste water, which is treated in the company's own WWTP. Although all statutory requirements are currently being met, the plant has set itself an ambitious target to increase eco-efficiency as part of its "Responsible Care Programme". After two years, the first net benefits are becoming clear. Over this period, it has been possible to achieve a 27 % reduction in the solvent load of waste water streams, which has not only had environmental benefits, but also measurable economic benefits. This has been achieved by various measures in the production plants, supported by:

- interdepartmental working teams ("matrix teams"), and
- direct employee participation in the resulting cost savings.

### Reference literature

(Regulation (EC) No 761/2001 of the European parliament and of the council allowing voluntary participation by organisations in a Community eco-management and audit scheme (EMAS), OJ L 114, 24/4/2001, [http://europa.eu.int/comm/environment/emas/index\\_en.htm](http://europa.eu.int/comm/environment/emas/index_en.htm))

(EN ISO 14001:1996, <http://www.iso.ch/iso/en/iso9000-14000/iso14000/iso14000index.html>;  
<http://www.tc207.org>)



## 5 BEST AVAILABLE TECHNIQUES

In understanding this chapter and its contents, the attention of the reader is drawn back to the preface of this document and in particular the fifth section of the preface: “How to understand and use this document”. The techniques and associated emission and/or consumption levels, or ranges of levels, presented in this chapter have been assessed through an iterative process involving the following steps:

- identification of the key environmental issues for the sector
- examination of the techniques most relevant to address these key issues
- identification of the best environmental performance levels, on the basis of the available data in the European Union and worldwide
- examination of the conditions under which these performance levels were achieved; such as costs, cross-media effects, and the main driving forces involved in implementation of the techniques
- selection of the best available techniques (BAT) and the associated emission and/or consumption levels for this sector in a general sense, all according to Article 2(11) and Annex IV of the Directive.

Expert judgement by the European IPPC Bureau and the relevant Technical Working Group (TWG) has played a key role in each of these steps and in the way in which the information is presented here.

On the basis of this assessment, techniques, and as far as possible emission and consumption levels associated with the use of BAT, are presented in this chapter that are considered to be appropriate to the sector as a whole and in many cases reflect the current performance of some installations within the sector. Where emission or consumption levels “associated with best available techniques” are presented, this is to be understood as meaning that those levels represent the environmental performance that could be anticipated as a result of the application, in this sector, of the techniques described, bearing in mind the balance of costs and advantages inherent within the definition of BAT. However, they are neither emission nor consumption limit values and should not be understood as such. In some cases it may be technically possible to achieve better emission or consumption levels but due to the costs involved or cross-media considerations, they are not considered to be appropriate as BAT for the sector as a whole. However, such levels may be considered to be justified in more specific cases where there are special driving forces.

The emission and consumption levels associated with the use of BAT have to be seen together with any specified reference conditions (e.g. averaging periods).

The concept of “levels associated with BAT” described above is to be distinguished from the term “achievable level” used elsewhere in this document. Where a level is described as “achievable” using a particular technique or combination of techniques, this should be understood to mean that the level may be expected to be achieved over a substantial period of time in a well maintained and operated installation or process using those techniques.

Where available, data concerning costs have been given together with the description of the techniques presented in the previous chapter. These give a rough indication about the magnitude of the costs involved. However, the actual cost of applying a technique will depend strongly on the specific situation regarding, for example, taxes, fees, and the technical characteristics of the installation concerned. It is not possible to evaluate such site-specific factors fully in this document. In the absence of data concerning costs, conclusions on economic viability of techniques are drawn from observations on existing installations.

It is intended that the general BAT in this chapter are a reference point against which to judge the current performance of an existing installation or to judge a proposal for a new installation. In this way they will assist in the determination of appropriate "BAT-based" conditions for the installation or in the establishment of general binding rules under Article 9(8). It is foreseen that new installations can be designed to perform at or even better than the general BAT levels presented here. It is also considered that existing installations could move towards the general BAT levels or do better, subject to the technical and economic applicability of the techniques in each case.

While the BAT reference documents do not set legally binding standards, they are meant to give information for the guidance of industry, Member States and the public on achievable emission and consumption levels when using specified techniques. The appropriate limit values for any specific case will need to be determined taking into account the objectives of the IPPC Directive and the local considerations.

### **Interfaces to other BREFs**

The BREF on "Common waste gas and waste water treatment/management systems in the chemical sector" (CWW) describes techniques which are commonly applicable to the whole spectrum of the chemical industry. As a result, only generic conclusions were derived, which de facto could not take into account the specific characteristics of the manufacture of Organic Fine Chemicals.

Using the results of the BREF on CWW as a source of information, the BREF on OFC provides a further assessment of such techniques in the OFC context. The main aspect is the effect of the operational mode (batch manufacture, production campaigns, frequent product changes) on the selection and the applicability of treatment techniques, as well as the implicit challenges of managing a multipurpose site. Furthermore, the performance is assessed and conclusions are drawn based on OFC specific information and data. For OFC installations, the results of the BREF on OFC take precedence over the general conclusions of the CWW BREF. With regard to indirect releases into water, e.g. joint treatment in industrial parks or in a municipal waste water treatment plant, Article 2(6) of the IPPC Directive requires to guarantee an equivalent level for the protection of the environment as a whole and the provision that the indirect release does not lead to higher levels of pollution in the environment.

Detailed descriptions of recovery or abatement techniques can be found in the BREF on CWW [31, European Commission, 2003]

BAT for the storage of bulk or dangerous materials are described in the BREF on Emissions from Storage [64, European Commission, 2005].

For good monitoring practices see the BREF on General Principles of Monitoring [108, European Commission, 2003].

Comparison of the conclusions of the BREF on OFC with other sectorial BREFs (so called "vertical" BREFs), e.g. the BREF on Surface Treatment using Solvents, is avoided by intention, because other sectors might have different environmental key issues and different economic balances.

### **Mass flow and concentration levels**

In this chapter, where general BAT associated emission levels are given both in terms of concentration and mass flow, that which represents the greater amount in specific cases is intended as the BAT reference. All BAT associated emission levels relate to emissions from point sources. Where not stated differently, emissions to air relate to Nm<sup>3</sup>.

## 5.1 Prevention and minimisation of environmental impact

### 5.1.1 Prevention of environmental impact

#### 5.1.1.1 Integration of environmental, health and safety considerations into process development

The likelihood of successful prevention and minimisation of the environmental impact of a process increases if environmental, health and safety issues are considered early in the process development chain. This is even more the case where production processes require validation procedures under other regulations, such as cGMP or approval by the European Medicine Evaluation Agency (EMA), the United States Food and Drug Administration (FDA) or other applicable medicine approval authorities in the case of API production. In such cases, retrofitting of a process would cause long and costly revalidation processes. The aim is to design out environmental issues and to provide an auditable trail for the assessment and consideration of environmental issues. However, often a compromise has to be found or one aspect has to be favoured over another. Examples for alternative synthesis and reaction conditions are given in Section 4.1.4. In reality, management and treatment of a wide variety of unavoidable waste streams remain crucial tasks on a multipurpose site (see Section 5.2).

**BAT is to provide an auditable trail for the integration of environmental, health and safety considerations into process development (see Section 4.1.2).**

**BAT is to develop new processes as follows (see Section 4.1.1):**

- a) to improve process design to maximise the incorporation of all the input materials used into the final product (see, e.g. Sections 4.1.4.3 and 4.1.4.8)
- b) to use substances that possess little or no toxicity to human health and the environment. Substances should be chosen in order to minimise the potential for accidents, releases, explosions and fires (e.g. for solvent selection, see Section 4.1.3).
- c) to avoid the use of auxiliary substances (e.g. solvents, separation agents, etc. see e.g. Section 4.1.4.2)
- d) to minimise energy requirements in recognition of the associated environmental and economic impacts. Reactions at ambient temperatures and pressures should be preferred
- e) to use renewable feedstock rather than depleting, wherever technically and economically practicable
- f) to avoid unnecessary derivatisation (e.g. blocking or protection groups)
- g) to apply catalytic reagents, which are typically superior to stoichiometric reagents (see, e.g. Sections 4.1.4.4 and 4.1.4.5)

### 5.1.1.2 Process safety and prevention of runaway reactions

Safety assessment is introduced in this document as it can help to prevent accidents with potentially significant environmental impacts. However, this subject could not be entirely dealt with in this document. The field of process safety is much wider than presented here. Section 4.1.6.3 contains a list of references for additional information.

#### 5.1.1.2.1 Safety assessment

**BAT is to carry out a structured safety assessment for normal operation and to take into account effects due to deviations of the chemical process and deviations in the operation of the plant (see Section 4.1.6).**

**In order to ensure that a process can be controlled adequately, BAT is to apply one or a combination of the following techniques (without ranking, see Section 4.1.6.1):**

- a) organisational measures
- b) concepts involving control engineering techniques
- c) reaction stoppers (e.g. neutralisation, quenching)
- d) emergency cooling
- e) pressure resistant construction
- f) pressure relief.

#### 5.1.1.2.2 Handling and storage of hazardous substances

Handling and storage of hazardous substances require precautions to limit the risks. On sites where toxic substances are handled, operators need sufficient and adequate knowledge to work safely in normal operation and to react adequately when deviations from normal operations occur:

**BAT is to establish and implement procedures and technical measures to limit risks from the handling and storage of hazardous substances (for an example, see Section 4.2.30).**

**BAT is to provide sufficient and adequate training for operators who handle hazardous substances (for an example, see Section 4.2.29).**

## 5.1.2 Minimisation of environmental impact

### 5.1.2.1 Plant design

The design of a plant is not easily changed, so for existing plants a step-by-step retrofitting is required. For example, the possibility of consequently using gravity flow depends on the production building actually available (five floors required) and may not be possible in many cases.

**BAT is to design new plants in such a way that emissions are minimised by applying techniques including the following (see Sections 4.2.1, 4.2.3, 4.2.14, 4.2.15, 4.2.21):**

- a) using closed and sealed equipment
- b) closing the production building and ventilating it mechanically
- c) using inert gas blanketing for process equipment where VOCs are handled
- d) connecting reactors to one or more condensers for solvent recovery
- e) connecting condensers to the recovery/abatement system
- f) using gravity flow instead of pumps (pumps can be an important source of fugitive emissions)
- g) enabling the segregation and selective treatment of waste water streams
- h) enabling a high degree of automation by application of a modern process control system in order to ensure a stable and efficient operation.

### 5.1.2.2 Ground protection and water retention options

**BAT is to design, build, operate and maintain facilities, where substances (usually liquids) which represent a potential risk of contamination of ground and groundwater are handled, in such a way that spill potential is minimised. Facilities have to be sealed, stable and sufficiently resistant against possible mechanical, thermal or chemical stress (see Section 4.2.27).**

**BAT is to enable leakages to be quickly and reliably recognised (see Section 4.2.27).**

**BAT is to provide sufficient retention volumes to safely retain spills and leaking substances in order to enable treatment or disposal (see Section 4.2.27).**

**BAT is to provide sufficient retention volume to safely retain fire fighting water and contaminated surface water (see Section 4.2.28).**

**BAT is to apply all the following techniques (see also Section 4.2.27):**

- a) carrying out loading and unloading only in designated areas protected against leakage run-off
- b) storing and collecting materials awaiting disposal in designated areas protected against leakage run-off
- c) fitting all pump sumps or other treatment plant chambers from which spillage might occur with high liquid level alarms or regularly supervising pump sumps by personnel instead
- d) establishing programmes for testing and inspecting tanks and pipelines including flanges and valves
- e) providing spill control equipment, such as containment booms and suitable absorbent material
- f) testing and demonstrating the integrity of bunds
- g) equipping tanks with overfill prevention.

### 5.1.2.3 Minimisation of VOC emissions

#### 5.1.2.3.1 Enclosure of sources

An example is the separation of solid products or intermediates from solvents in closed systems. This is realised consequently by the application of filter dryers or by keeping the system closed when discharging the wet filter cake for subsequent operations (see Section 4.2.19).

**BAT is to contain and enclose sources and to close any openings in order to minimise uncontrolled emissions (see Section 4.2.14).**

#### 5.1.2.3.2 Drying in closed circuits

**BAT is to carry out drying by using closed circuits, including condensers for solvent recovery (see Section 4.2.14).**

#### 5.1.2.3.3 Equipment cleaning using solvents

Often, the cleaning of equipment (e.g. vessels) is finished with a final rinse with solvent. The equipment is kept closed and residual solvent is removed by applying vacuum and/or by slightly heating and removing vapours after the emptying of the vessel (see Section 4.2.13).

**BAT is to keep equipment closed for rinsing and cleaning with solvents (see Section 4.2.14).**

#### 5.1.2.3.4 Recirculation of process vents

**BAT is to use recirculation of process vapours where purity requirements allow this (see Section 4.2.14).**

### 5.1.2.4 Minimisation of exhaust gas volume flows and loads

#### 5.1.2.4.1 Closure of openings

At a given temperature (e.g. set by a condenser), the decisive parameter to control the mass flow of an exhaust gas is the volume flow.

**BAT is to close any unnecessary openings in order to prevent air being sucked to the gas collection system via the process equipment (see Sections 4.2.14 and 4.3.5.17).**

#### 5.1.2.4.2 Testing the airtightness of process equipment

This is carried out by closing and sealing all openings until the equipment holds a vacuum or a pressure (e.g. a vacuum of about 100 mbar for at least 30 minutes).

**BAT is to ensure the airtightness of process equipment, especially of vessels (see Section 4.2.16).**

#### 5.1.2.4.3 Inertisation

Testing airtightness of the equipment is carried out regularly and enables the application of shock inertisation instead of continuous inertisation. Still, continuous inertisation has to be accepted due to safety requirements, e.g. where processes generate O<sub>2</sub> or where processes require further loading of material after inertisation.

**BAT is to apply shock inertisation instead of continuous inertisation (see Section 4.2.17).**

#### 5.1.2.4.4 Minimisation of exhaust gas volume flows from distillations

Exhaust gas volume flows from distillations can be minimised to almost zero if the layout of the condenser allows sufficient heat removal.

**BAT is to minimise the exhaust gas volume flows from distillations by optimising the layout of the condenser (see Section 4.2.20).**

#### 5.1.2.4.5 Liquid additions into vessels

Liquid addition to a vessel is possible as top feed or as bottom feed or with dip-leg. In the case of an organic liquid, the organic load in the displaced gas is about 10 to 100 times higher if added via top feed. If both solids and an organic liquid are added to the vessel, the solids can be used as a dynamic lid in the case of bottom feeding the liquid:

**BAT is to carry out liquid addition to vessels as bottom feed or with dip-leg, unless reaction chemistry and/or safety considerations make it impractical (see Sections 4.2.15, 4.2.18). In such cases, the addition of liquid as top feed with a pipe directed to the wall reduces splashing and hence, the organic load in the displaced gas.**

**If both solids and an organic liquid are added to a vessel, BAT is to use solids as a blanket in circumstances where the density difference promotes the reduction of the organic load in the displaced gas, unless reaction chemistry and/or safety considerations make it impractical (see Section 4.2.18).**

#### 5.1.2.4.6 Minimisation of peak emission concentrations

A characteristic aspect of batch processes is the variation of pollutant load and volume flow in exhaust gases. Such variations represent a challenge for the operation of recovery or abatement techniques and result frequently in undesirable emission concentration peaks potentially representing a higher environmental impact:

**BAT is to minimise the accumulation of peak loads and flows and related emission concentration peaks by, e.g.**

- a) optimisation of the production matrix (see Section 4.3.5.17)
- b) application of smoothing filters (see Section 4.3.5.16 and also Section 4.3.5.13).

### 5.1.2.5 Minimisation of volume and load of waste water streams

#### 5.1.2.5.1 Mother liquors with high salt content

The separation of products or intermediates from aqueous solutions frequently creates highly loaded aqueous mother liquors. Especially where the product is obtained by salting out or bulk neutralisation, a work-up of such mother liquors is often hindered by the high salt content. Alternative separation of products or intermediates can increase yields or even the product quality, but the technical applicability of alternative separation techniques needs to be assessed for each case individually. For examples, see Sections 4.2.4, 4.2.25 and 4.2.26.

**BAT is to avoid mother liquors with high salt content or to enable the work-up of mother liquors by the application of alternative separation techniques (see Section 4.2.24), e.g.**

- a) membrane processes
- b) solvent-based processes
- c) reactive extraction
- d) or to omit intermediate isolation.

#### 5.1.2.5.2 Countercurrent product washing

As a polishing step, organic products are often washed with an aqueous phase in order to remove impurities. High efficiencies in combination with low water consumption (and low waste water generation) can be achieved with countercurrent washing. However, the degree of optimisation of the washing process depends on the production level and regularity. With small amounts, experimental production runs and rare production campaigns, countercurrent product washing is not applicable.

**BAT is to apply countercurrent product washing where the production scale justifies the introduction of the technique (see Section 4.2.22).**

#### 5.1.2.5.3 Water-free vacuum generation

Water-free vacuum generation is realised by using, e.g. dry running pumps, liquid ring pumps using solvents as the ring medium or closed cycle liquid ring pumps. However, where the applicability of these techniques is restricted (see cross-references below), the use of steam injectors or water ring pumps is justified.

**BAT is to apply water-free vacuum generation (see Sections 4.2.5, 4.2.6 and 4.2.7).**

#### 5.1.2.5.4 Determination of the completion of reactions

The precise determination of a chemical process completion minimises the potential load in waste water streams caused by a batch process.

**For batch processes, BAT is to establish clear procedures for the determination of the desired end point of the reaction (for an example, see Section 4.2.23).**



#### 5.1.2.5.5 Indirect cooling

Indirect cooling is not applicable for processes which require the addition of water or ice to enable safe temperature control, temperature jumps or temperature shock. Direct cooling can also be required to control “run away” situations (see Section 4.1.6.2) or where there are concerns about blocking heat-exchangers.

**BAT is to apply indirect cooling (see Section 4.2.9).**

#### 5.1.2.5.6 Cleaning

Production plant cleaning procedures can be optimised to reduce the resulting waste water loads. In particular, the introduction of an additional cleaning step (pre-rinsing) enables the separation of large portions of solvents from wash-waters. Where different materials are frequently transported in pipes, the use of pigging technology represents another option to reduce product losses within cleaning procedures (see Section 4.2.8).

**BAT is to apply a pre-rinsing step prior to rinsing/cleaning of equipment to minimise organic loads in wash-waters (see Section 4.2.12).**

#### 5.1.2.6 Minimisation of energy consumption

On an OFC site, a wide variety of processes/operations involve cooling and heating, heat-exchange or the use of temperature profiles. An obvious example to optimise heat consumption is the use of residual heat as energy input to another process, for example in the case of energetically coupled distillations. As another example, Section 4.2.10 gives the basic concept of the Pinch methodology which has been applied successfully on an OFC site operating batch processes with 30 reactors and over 300 products achieving cost savings and quick paybacks.

**BAT is to assess the options and to optimise the energy consumption (for examples, see Sections 4.2.11 and 4.2.20).**

## 5.2 Management and treatment of waste streams

Management and treatment of a wide variety of unavoidable waste streams are crucial tasks on a multipurpose site. However, as an alternative to the investment of recovery/abatement techniques, a modernisation of the process should always be assessed as an option in order to prevent or minimise waste stream volumes or loads, close cycles or enable on-site or off-site re-use (see BAT in Section 5.1, and for examples see Sections 4.1.4.2 and 4.1.4.3). The operational mode and frequent product change on a multipurpose site naturally favour flexible recovery/abatement solutions, e.g. modular concepts (see Section 4.3.5.17) or techniques fulfilling several tasks efficiently and simultaneously (for examples see Sections 4.2.1 and 4.3.5.7). In addition, external treatment should always be considered as an option, including solutions such as joint pretreatment/treatment platforms for waste water streams as shown in Section 4.3.7.4.

### 5.2.1 Mass balances and process waste stream analysis

Mass balances are important tools for understanding a multipurpose production and the development of priorities for improvement strategies. The management of waste streams is based on the knowledge of the properties of the occurring waste stream and the monitoring of the results of the treatment of waste streams, including the final emission data.

#### 5.2.1.1.1 Mass balances

**BAT is to establish mass balances for VOCs (including CHCs), TOC or COD, AOX or EOX and heavy metals on a yearly basis (see Sections 4.3.1.4, 4.3.1.5 and 4.3.1.6).**

#### 5.2.1.1.2 Waste stream analysis

**BAT is to carry out a detailed waste stream analysis in order to identify the origin of the waste stream and a basic data set to enable management and suitable treatment of exhaust gases, waste water streams and solid residues (see Section 4.3.1.1).**

#### 5.2.1.1.3 Assessment of waste water streams

**BAT is to assess at least the parameters given in Table 5.1 for waste water streams, unless the parameter can be seen as irrelevant from a scientific point of view (see Section 4.3.1.2).**

Parameter	
Volume per batch	Standard
Batches per year	
Volume per day	
Volume per year	
COD or TOC	
BOD <sub>5</sub>	
pH	
Bioeliminability	
Biological inhibition, including nitrification	
AOX	
CHCs	
Solvents	
Heavy metals	
Total N	
Total P	
Chloride	
Bromide	
SO <sub>4</sub> <sup>2-</sup>	
Residual toxicity	

**Table 5.1: Parameters for the assessment of waste water streams**

#### 5.2.1.1.4 Monitoring of emissions to air

Monitoring of waste gas emissions should reflect the operational mode of the production processes (batch, semi-continuous or continuous) and should also take into account the emission of individual substances, especially if substances with ecotoxicological potential are released. Therefore, emission profiles should be recorded instead of levels derived from short sampling periods. Emission data should be related to the operations responsible.

**For emissions to air, BAT is to monitor the emission profile which reflects the operational mode of the production process (see Section 4.3.1.8).**

**In the case of a non-oxidative abatement/recovery system, BAT is to apply a continuous monitoring system (e.g. FID), where exhaust gases from various processes are treated in a central recovery/abatement system (see Section 4.3.1.8).**

**BAT is to individually monitor substances with ecotoxicological potential if such substances are released (see Section 4.3.1.8).**

### 5.2.1.1.5 Assessment of individual volume flows

The key to the understanding of the waste gas emission situation and the basis of improvement strategies is the knowledge of the individual contribution of processes and operations to the volume flow to recovery and abatement systems.

**BAT is to assess individual exhaust gas volume flows from process equipment to recovery/abatement systems (see Section 4.3.1.7).**

### 5.2.2 Re-use of solvents

**BAT is to re-use solvents as far as purity requirements (e.g. requirements according to cGMP) allow, by:**

- a) using the solvent from previous batches of a production campaign for future batches as far as purity requirements allow (see Section 4.3.4)
- b) collecting spent solvents for on-site or off-site purification and re-use (for an example, see Section 4.3.3)
- c) collecting spent solvents for on-site or off-site utilisation of the calorific value (see Section 4.3.5.7).

### 5.2.3 Treatment of exhaust gases

#### 5.2.3.1 Selection of VOC recovery/abatement techniques and achievable emission levels

The selection of VOC treatment techniques is a crucial task on a multipurpose site. Since the volume flows show a wide variation on a multipurpose site, the key parameter for the selection of techniques are average mass flows from emission point sources in kg/hour. One or a combination of techniques can be applied as a recovery/abatement system for a whole site, an individual production building, or an individual process. This depends on the particular situation and affects the number of point sources.

##### 5.2.3.1.1 Selection of VOC and recovery abatement techniques

**BAT is to select VOC recovery and abatement techniques according to the flow scheme in Figure 5.1.**

##### 5.2.3.1.2 Non-oxidative VOC recovery and abatement techniques

Non-oxidative recovery/abatement techniques are operated efficiently after minimisation of volume flows (see Section 5.1.2.4) and the achieved concentration levels should be related to the corresponding volume flow without dilution by, e.g. volume flows from building or room ventilation.

**BAT is to reduce emissions to the levels given in Table 5.2 where non-oxidative VOC recovery or abatement techniques are applied (see Sections 4.3.5.6, 4.3.5.11, 4.3.5.14, 4.3.5.17, 4.3.5.18).**

Parameter	Average emission level from point sources*
Total organic C	0.1 kg C/hour or 20 mg C/m <sup>3</sup> **
* The averaging time relates to the emission profile (see Sections 5.2.1.1.4 and 4.3.1.8), the levels relate to dry gas and Nm <sup>3</sup> ** The concentration level relates to volume flows without dilution by, e.g. volume flows from room or building ventilation	

**Table 5.2: BAT associated VOC emission levels for non-oxidative recovery/abatement techniques**

### 5.2.3.1.3 VOC abatement by thermal oxidation/incineration and catalytic oxidation

Thermal oxidation/incineration and catalytic oxidation are proven techniques for destroying VOCs with highest efficiency but show considerable cross-media effects. In direct comparison, catalytic oxidation consumes less energy and creates less NO<sub>x</sub> and hence is preferred where technically possible. Thermal oxidation is advantageous where support fuel can be replaced by organic liquid waste (e.g. waste solvents which are technically/economically available on-site and non-recoverable) or where autothermal operation can be enabled by stripping of organic compounds from waste water streams (see Section 4.3.5.9 and BAT in Section 5.2.4.3). Where exhaust gases also contain high loads of other pollutants besides VOCs, thermal oxidation can enable, e.g. the recovery of marketable HCl (see Section 4.3.5.2) or, if the thermal oxidiser is equipped with a DeNO<sub>x</sub> unit or is designed as two stage combustion, the efficient abatement of NO<sub>x</sub> (see Section 4.3.5.7). Thermal oxidation/incineration and catalytic oxidation can also be a suitable technique to reduce odour emissions.

**BAT is to reduce VOC emissions to the levels given in Table 5.3 where thermal oxidation/incineration or catalytic oxidation are applied (see Sections 4.3.5.7, 4.3.5.8, 4.3.5.18).**

Thermal oxidation/incineration or catalytic oxidation	Average mass flow kg C/hour		Average concentration mg C/m <sup>3</sup>
Total organic C	<0.05	or	<5
The averaging time relates to the emission profile (see Section 5.2.1.1.4), levels relate to dry gas and Nm <sup>3</sup>			

**Table 5.3: BAT associated emission levels for total organic C for thermal oxidation/incineration or catalytic oxidation**

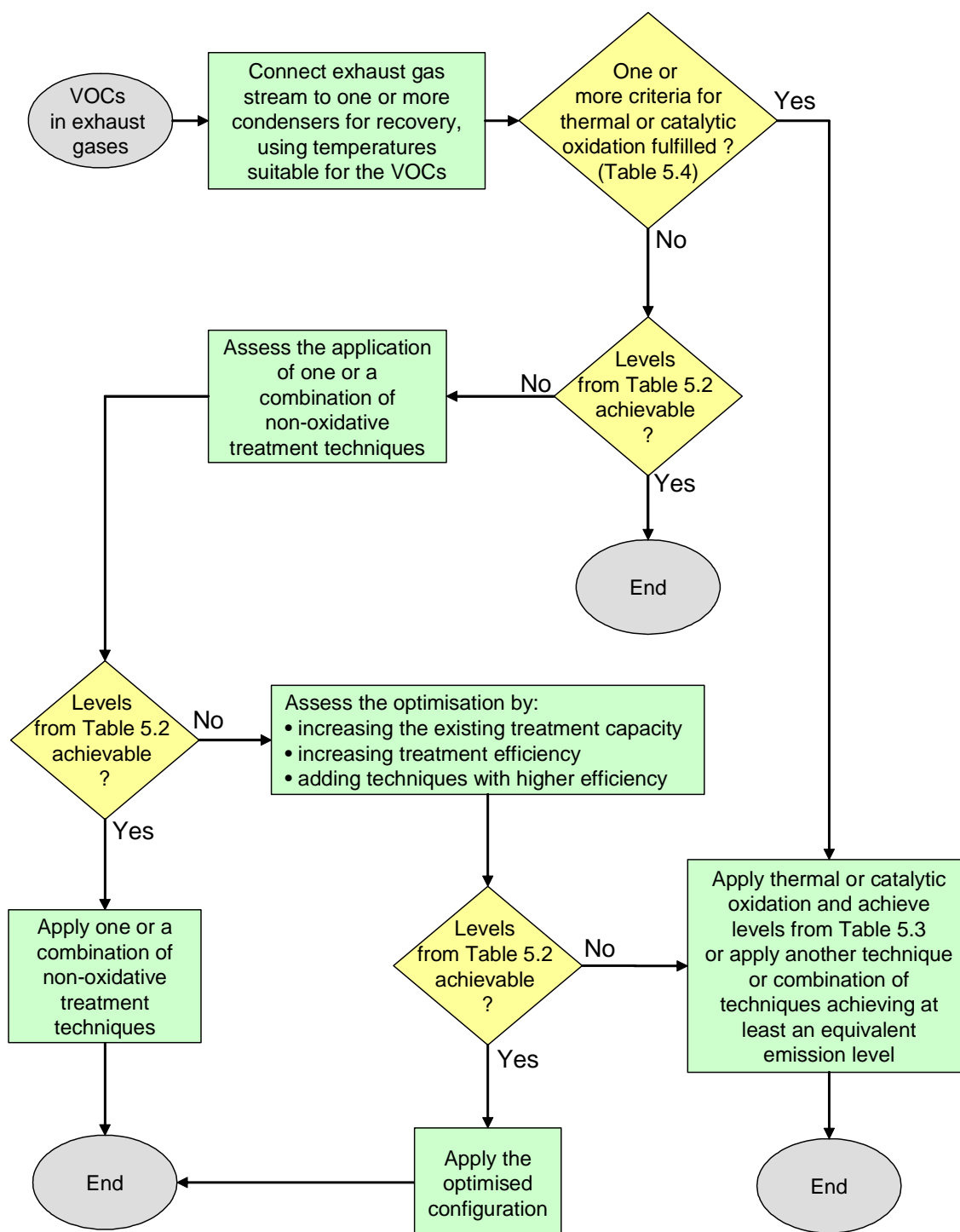

Figure 5.1: BAT for the selection of VOC recovery/abatement techniques

	Selection criteria
a	the exhaust gas contains very toxic, carcinogenic or cmr category 1 or 2 substances, or
b	autothermal operation is possible in normal operation, or
c	overall reduction of primary energy consumption is possible in the installation (e.g. secondary heat option)

Table 5.4: Selection criteria for catalytic and thermal oxidation/incineration

### 5.2.3.2 Recovery/abatement of NO<sub>x</sub>

#### 5.2.3.2.1 NO<sub>x</sub> from thermal oxidation/incineration or catalytic oxidation

For thermal oxidation/incineration or catalytic oxidation, BAT is to achieve the NO<sub>x</sub> emission levels given in Table 5.5 and, where necessary, to apply a DeNO<sub>x</sub> system (e.g. SCR or SNCR) or two stage combustion to achieve such levels (see Sections 4.3.5.7 and 4.3.5.19).

#### 5.2.3.2.2 NO<sub>x</sub> from chemical processes

Where NO<sub>x</sub> is absorbed from strong NO<sub>x</sub> streams (about 1000 ppm and higher) a 55 % HNO<sub>3</sub> can be obtained for on-site or off-site re-use. Often, exhaust gases containing NO<sub>x</sub> from chemical processes also contain VOCs and can be treated in a thermal oxidiser/incinerator, e.g. equipped with a DeNO<sub>x</sub> unit or built as a two stage combustion (where already available on-site).

For exhaust gases from chemical production processes, BAT is to achieve the NO<sub>x</sub> emission levels given in Table 5.5 and, where necessary to apply treatment techniques such as scrubbing or scrubber cascades with scrubber media such as H<sub>2</sub>O and/or H<sub>2</sub>O<sub>2</sub> to achieve such levels (see Section 4.3.5.1).

Source	Average mass flow kg/hour*		Average concentration mg/m <sup>3</sup> *	Comment
Chemical production processes, e.g. nitration, recovery of spent acids	0.03 – 1.7	or	7 – 220**	The lower end of the range relates to low inputs to the scrubbing system and scrubbing with H <sub>2</sub> O. With high input levels, the lower end of the range is not achievable even with H <sub>2</sub> O <sub>2</sub> as the scrubbing medium
Thermal oxidation/incineration, catalytic oxidation	0.1 – 0.3		13 – 50***	
Thermal oxidation/incineration, catalytic oxidation, input of nitrogenous organic compounds			25 – 150***	Lower range with SCR, upper range with SNCR
* NO <sub>x</sub> expressed as NO <sub>2</sub> , the averaging time relates to the emission profile (see Section 5.2.1.1.4)				
** Levels relate to dry gas and Nm <sup>3</sup>				
*** Levels relate to dry gas and Nm <sup>3</sup>				

**Table 5.5: BAT associated NO<sub>x</sub> emission levels**

### 5.2.3.3 Recovery/abatement of HCl, Cl<sub>2</sub> and HBr/Br<sub>2</sub>

HCl is removed from exhaust gases with one or more scrubbers using scrubbing media such as H<sub>2</sub>O or NaOH (see Section 4.3.5.3). HCl can be efficiently recovered from exhaust gases with high HCl concentrations, if the production volume justifies the investment costs for the required equipment. This can be expected where production lines are dedicated to a larger volume product or to a range of similar products. For an example, see Section 4.3.5.2. Where HCl recovery is not preceded by VOC removal, potential organic contaminants (AOX) have to be considered in the recovered HCl. Similarly, Cl<sub>2</sub> requires additional measures if present in the exhaust gas. HBr and Br<sub>2</sub> are recovered/removed under similar conditions from exhaust gases (see Section 4.3.5.4).

**BAT is to achieve HCl emission levels of 0.2 – 7.5 mg/m<sup>3</sup> or 0.001 – 0.08 kg/hour and, where necessary, to apply of one or more scrubbers using scrubbing media such as H<sub>2</sub>O or NaOH in order to achieve such levels (see Section 4.3.5.3).**

**BAT is to achieve Cl<sub>2</sub> emission levels of 0.1 – 1 mg/m<sup>3</sup> and, where necessary, to apply techniques such as absorption of the excess chlorine (see Section 4.3.5.5) and/or scrubbing with scrubbing media such as NaHSO<sub>3</sub> in order to achieve such levels (see Section 4.3.5.2).**

**BAT is to achieve HBr emission levels <1 mg/m<sup>3</sup> and, where necessary, to apply scrubbing with scrubbing media such as H<sub>2</sub>O or NaOH in order to achieve such levels (see Sections 1.1.1, 4.3.5.4).**

### 5.2.3.4 NH<sub>3</sub> emission levels

#### 5.2.3.4.1 Removal of NH<sub>3</sub> from exhaust gases

**BAT is to achieve NH<sub>3</sub> emission levels of 0.1 – 10 mg/m<sup>3</sup> or 0.001 – 0.1 kg/hour and, where necessary, to apply scrubbing with scrubbing media such as H<sub>2</sub>O or acid in order to achieve such levels (see Section 4.3.5.20).**

#### 5.2.3.4.2 NH<sub>3</sub> slip from DeNO<sub>x</sub>

**BAT is to achieve NH<sub>3</sub> slip levels from SCR or SNCR of <2 mg/m<sup>3</sup> or <0.02 kg/hour (see Section 4.3.5.7).**

### 5.2.3.5 Removal of SO<sub>x</sub> from exhaust gases

**BAT is to achieve SO<sub>x</sub> emission levels of 1 – 15 mg/m<sup>3</sup> or 0.001 – 0.1 kg/hour and, where necessary, to apply scrubbing with scrubbing media such as H<sub>2</sub>O or NaOH in order to achieve such levels (see Section 4.3.5.21).**



### 5.2.3.6 Removal of particulates from exhaust gases

Particulates are removed from various exhaust gases. The choice of recovery/abatement systems depends strongly on the particulate properties.

**BAT is to achieve particulate emission levels of 0.05 – 5 mg/m<sup>3</sup> or 0.001 – 0.1 kg/hour and, where necessary, to apply techniques such as bag filters, fabric filters, cyclones, scrubbing, or wet electrostatic precipitation (WESP) in order to achieve such levels (see Section 4.3.5.22).**

### 5.2.3.7 Removal of free cyanides from exhaust gases

Due to their toxicity, cyanides are removed from rich and lean exhaust gases by scrubbing.

**BAT is to remove free cyanides from exhaust gases, and to achieve a waste gas emission level of 1 mg/m<sup>3</sup> or 3 g/hour as HCN (see Section 4.3.6.2).**

## 5.2.4 Management and treatment of waste water streams

### 5.2.4.1 Typical waste water streams for segregation, pretreatment or disposal

Some types of waste water streams are typical candidates for segregation and selective pretreatment or disposal due to their characteristic properties.

#### 5.2.4.1.1 Mother liquors from halogenation and sulphochlorination

**BAT is to segregate and pretreat or dispose of mother liquors from halogenations and sulphochlorinations (see Sections 4.3.2.5, 4.3.2.10).**

#### 5.2.4.1.2 Waste water streams containing biologically active substances

Examples are, e.g. waste water streams from the production of biocides/plant health products or wash-waters from product washing after the nitration of aromates, typically containing (nitro-) phenols.

**BAT is to pretreat waste water streams containing biologically active substances at levels which could pose a risk either to a subsequent waste water treatment or to the receiving environment after discharge (see Sections 4.3.2.6, 4.3.7.5, 4.3.7.9, 4.3.8.13 and 4.3.8.18).**

#### 5.2.4.1.3 Spent acids from sulphonations or nitrations

Spent acids from sulphonations or nitrations can usually be recovered. Where recovery is not possible, e.g. due to a high salt content (see also BAT in Section 5.1.2.5.1), pretreatment can be necessary according to the BAT given in 5.2.4.2. An example is the extraction of mother liquors from nitrations after phase separation (see Section 4.3.2.6).

**BAT is to segregate and collect separately spent acids, e.g. from sulphonations or nitrations for on-site or off-site recovery or to apply BAT given in 5.2.4.2 (see Sections 4.3.2.6, 4.3.2.8).**

### 5.2.4.2 Treatment of waste water streams with relevant refractory organic load

The refractory organic load of a waste water stream passes through the biological WWTP more or less unchanged and requires pretreatment prior to biological treatment (see Section 4.3.7.10). Pretreatment techniques include oxidative techniques (e.g. see Section 4.3.7.2) and non-destructive techniques (e.g. see Section 4.3.7.1) and alternatively the disposal option (incineration). Two main strategies are available for pretreatment: elimination of refractory loadings or enhancing the biodegradability of such loadings (compare Sections 4.3.7.6 and 4.3.7.12). However, as an alternative to the investment of pretreatment techniques a modernisation of the process should always be assessed as an option in order to prevent or minimise the refractory load of a waste water stream. The main criterion for this is the bioeliminability. If the actual production spectrum causes poorly bioeliminable organic loadings in most of the waste water streams (e.g. manufacture of dyes, optical brighteners, aromatic intermediates), the refractory load is introduced as selection criterion in order to set priorities. Bioeliminabilities and, hence, the refractory organic load are related to the assessment of the inherent bioeliminability, e.g. by Zahn-Wellens test (see Section 4.3.1.3). Instead of the 80 % from inherent bioeliminability testing, for screening purposes, a BOD<sub>5</sub>/COD ratio of 0.6 can be used. For examples of waste water streams from different unit processes, see Section 4.3.2. The development of pretreatment strategies for refractory loads is not viable in cases of experimental production runs and rare batch production.

#### 5.2.4.2.1 Relevant refractory organic loading

**For the purposes of pretreatment, BAT is to classify organic loading as follows:**

**Refractory organic loading is not relevant if the waste water stream shows a bioeliminability of greater than about 80 – 90 % (see Sections 4.3.7.6, 4.3.7.7, 4.3.7.8). In cases with lower bioeliminability, the refractory organic loading is not relevant if it is lower than the range of about 7.5 – 40 kg TOC per batch or per day (see Sections 4.3.7.10, 4.3.7.12 and 4.3.7.13).**

#### 5.2.4.2.2 Segregation and pretreatment

**BAT is to segregate and pretreat waste water streams containing relevant refractory organic loadings according to the criteria given in Section 5.2.4.2.1.**

#### 5.2.4.2.3 Overall COD elimination

**For the segregated waste water streams carrying a relevant refractory organic load according to Section 5.2.4.2.1, BAT is to achieve overall COD elimination rates for the combination of pretreatment and biological treatment of >95 % (see Section 4.3.8.9).**

### 5.2.4.3 Removal of solvents from waste water streams

Because of the volumes used, solvents are often a big environmental impact of a process. Hence, recovery and re-use of solvents, or at least the utilisation of the calorific value, is an important task. Recovery of solvents from waste water streams for re-use is always viable if:

$$\begin{array}{l} \text{Costs for biological treatment} \\ + \text{purchase costs for fresh solvents} \end{array} > \begin{array}{l} \text{Costs for recovery} \\ + \text{purification} \end{array}$$

Recovery of solvents from waste water streams in order to use the calorific value is environmentally advantageous always if the energy balance (comparison of biological WWTP on one side and stripping/distillation/thermal oxidation on the other side) shows that overall natural fuel can be substituted. As a result for many solvents, a target of 1 g/l in waste water streams is used. The target is higher for cheap solvents (e.g. for methanol, ethanol 10 – 15 g/l) and for solvents which require higher efforts to be purified (for orientation, see Section 4.3.7.18). Rapidly degradable solvents can also represent a necessary C-source for a biological WWTP (e.g. see Section 4.3.8.8). Combinations of techniques such as stripping/incineration can represent an efficient and viable alternative to treatment in the biological WWTP and can also alter the economic/energetic balance in favour of thermal oxidation/incineration as the main exhaust gas abatement system (see Section 4.3.5.9). Besides the economic or energetic balance, the removal of solvents from waste water streams can also be required in order to protect downstream pretreatment facilities, such as activated carbon adsorption. For halogenated solvents, apply BAT in Section 5.2.4.4, for poorly bioeliminable solvents, apply BAT in Section 5.2.4.2.

**BAT is to recover solvents from waste water streams for on-site or off-site re-use, using techniques such as stripping, distillation/rectification, extraction or combinations of such techniques, where the costs for biological treatment and purchase of fresh solvents are higher than the costs for recovery and purification (see Section 4.3.7.18).**

**BAT is to recover solvents from waste water streams in order to use the calorific value if the energy balance shows that overall natural fuel can be substituted (see Section 4.3.5.7).**

### 5.2.4.4 Removal of halogenated compounds from waste water streams

#### 5.2.4.4.1 Removal of purgeable chlorinated hydrocarbons

Purgeable chlorinated hydrocarbons (CHCs) show ecotoxicological potential and are being substituted as solvents where technically possible. Where CHCs are still in use, all efforts are undertaken to remove such compounds from waste water streams.

**BAT is to remove purgeable CHCs from waste water streams, e.g. by stripping, rectification or extraction and to achieve sum concentrations <1 mg/l in the outlet from pretreatment or to achieve sum concentrations of <0.1 mg/l in the inlet to the on-site biological WWTP or in the inlet to the municipal sewerage system (see Sections 4.3.7.18, 4.3.7.19, 4.3.7.20).**

#### 5.2.4.4.2 Pretreatment of waste water streams containing AOX

In some Member States, AOX is a well established screening parameter for the assessment of halogenated organic compounds in aqueous solutions. In other Member States, AOX as a parameter is just being established and step-by-step implementation will be necessary in many cases. The main factor to actively influence the emission level of AOX is the segregation and selective pretreatment of waste water streams from processes with AOX relevance. For examples and applied techniques, see Sections 4.3.7.15, 4.3.7.16, 4.3.7.17, 4.3.7.23.

**BAT is to pretreat waste water streams with significant AOX loads and to achieve the AOX levels given in Table 5.6 in the inlet to the on-site biological WWTP or in the inlet to the municipal sewerage system (see Section 4.3.7.14).**

Parameter	Yearly average levels	Unit	Comment
AOX	0.5 – 8.5	mg/l	The upper range relates to cases where halogenated compounds are processed in numerous processes and the corresponding waste water streams are pretreated and/or where the AOX is very bioeliminable.

**Table 5.6: BAT associated AOX levels in the inlet to the on-site biological WWTP or in the inlet to the municipal sewerage system**

#### 5.2.4.5 Pretreatment of waste water streams containing heavy metals

The main factor to actively influence the emission level of heavy metals is the segregation and selective pretreatment of waste water streams from processes where heavy metals are used deliberately. For examples and applied pretreatment techniques, see Sections 4.2.25, 4.3.2.4, 4.3.7.3, 4.3.7.21. If equivalent removal levels can be demonstrated in comparison with the combination of pretreatment and biological waste water treatment, heavy metals can be eliminated from the total effluent using only the biological waste water treatment process, provided that the biological treatment is carried out on-site and the treatment sludge is incinerated.

**BAT is to pretreat waste water streams containing significant levels of heavy metals or heavy metal compounds from processes where they are used deliberately and to achieve the heavy metal concentrations given in Table 5.7 in the inlet to the on-site biological WWTP or in the inlet to the municipal sewerage system (see Section 4.3.7.22).**

Parameter	Yearly average levels	Unit	Comment
Cu	0.03 – 0.4	mg/l	The upper ranges result from the deliberate use of heavy metals or heavy metal compounds in numerous processes and the pretreatment of waste water streams from such use.
Cr	0.04 – 0.3		
Ni	0.03 – 0.3		
Zn	0.1 – 0.5		

**Table 5.7: BAT associated levels for heavy metals in the inlet to the on-site biological WWTP or in the inlet to the municipal sewerage system**

#### 5.2.4.6 Destruction of free cyanides

Due to their toxicity, cyanides are removed from rich and lean waste water streams, e.g. by pH adjustment and oxidative destruction with H<sub>2</sub>O<sub>2</sub> (for other techniques, see Section 4.3.6.2 under Applicability). Depending on the individual case, it may be also possible to enable safe degradation of cyanides in a biological WWTP (see Section 4.3.6.2 under Applicability). The use of NaOCl for pretreatment is not considered as BAT due to the potential for formation of AOX. Reconditioning of different cyanide loaded streams can enable re-use and substitution of raw materials. Cyanides occurring in waste water streams together with high COD loads can be pretreated oxidatively by techniques such as wet oxidation with O<sub>2</sub> under alkaline conditions. In such cases, cyanide levels <1 mg/l are achievable in the treated waste water stream (see Section 4.3.7.4).

**BAT is to recondition waste water streams containing free cyanides in order to substitute raw materials where technically possible (see Section 4.3.6.2).**

**BAT is to:**

- a) **pretreat waste water streams containing significant loads of cyanides and to achieve a cyanide level of 1 mg/l or lower in the treated waste water stream (see Section 4.3.6.2) or to**
- b) **enable safe degradation in a biological WWTP (see Section 4.3.6.2 under Applicability).**

#### 5.2.4.7 Biological waste water treatment

**After the application of BAT given in Sections 5.2.4.1, 5.2.4.2, 5.2.4.3, 5.2.4.4 and 5.2.4.5 (management and treatment of waste water streams), BAT is to treat effluents containing a relevant organic load, such as waste water streams from production processes, rinsing and cleaning water, in a biological WWTP (see Sections 4.3.8.6 and 4.3.8.10).**

##### 5.2.4.7.1 On-site and joint treatment

Biological waste water treatment is carried out on-site or as joint treatment with other industrial waste waters or together with municipal waste water. Joint treatment can have advantages and disadvantages (see Section 4.3.8.4) and the biological treatment of a complex effluent from an OFC site requires a high level of communication between production and WWTP. An important aspect is the protection of the biological treatment from variations of the input properties, e.g. load or toxicity (see Sections 4.3.7.5, 4.3.8.4, 4.3.8.6, 4.3.8.7). Where stable operation cannot be ensured, retrofitting to a more reliable setup is required (see Sections 4.3.8.3, 4.3.8.8). This retrofitting may include the change-over from joint treatment with municipal waste water to on-site treatment.

**BAT is to ensure that the elimination in a joint waste water treatment is overall not poorer than in the case of on-site treatment. This is realised by regular degradability/bioeliminability testing (see Section 4.3.8.5).**

## 5.2.4.7.2 Elimination rates and emission levels

For biological waste water treatment, COD elimination rates of 93 – 97 % are typically achievable as a yearly average. It is important that a COD elimination rate cannot be understood as a standalone parameter, but is influenced by the production spectrum (e.g. production of dyes/pigments, optical brighteners, aromatic intermediates which create refractory loadings in most of the waste water streams on a site), the degree of solvent removal (see Section 4.3.7.18) and the degree of pretreatment of refractory organic loadings (see Sections 4.3.8.7 and 4.3.8.10). Depending on the individual situation, retrofitting of the biological WWTP is required in order to adjust, e.g. treatment capacity or buffer volume or the application of a nitrification/denitrification or a chemical/mechanical stage (e.g. see Section 4.3.8.8). In some Member States, AOX is a well established screening parameter for the assessment of halogenated organic compounds in an aqueous solution. In other Member States, AOX as a parameter is just being established and step-by-step implementation will be necessary in many cases. The main factor to actively influence the heavy metal emission levels is the segregation and selective pretreatment of waste water streams (see Section 4.3.7.22).

**BAT is to take full advantage of the biological degradation potential of the total effluent and to achieve BOD elimination rates above 99 % and yearly average BOD emission levels of 1 – 18 mg/l. The levels relate to the effluent after biological treatment without dilution, e.g. by mixing with cooling water (see Section 4.3.8.11).**

**BAT is to achieve the emission levels given in Table 5.8.**

Parameter	Yearly averages*		Comment
	Level	Unit	
COD	12 – 250	mg/l	see Section 4.3.8.10
Total P	0.2 – 1.5		The upper range results from the production of mainly compounds containing phosphorus (see Sections 4.3.7.24, 4.3.8.16, 4.3.8.17)
Inorganic N	2 – 20		The upper range results from production of mainly organic compounds containing nitrogen or from, e.g. fermentation processes (see Sections 4.3.2.11 and 4.3.8.14)
AOX	0.1 – 1.7		The upper range results from numerous AOX relevant productions and pretreatment of waste water streams with significant AOX loads (see Sections 4.3.8.12, 5.2.4.4.2).
Cu	0.007 – 0.1		The upper ranges result from the deliberate use of heavy metals or heavy metal compounds in numerous processes and the pretreatment of waste water streams from such use (see Sections 4.3.7.22, 4.3.8.1, 5.2.4.5).
Cr	0.004 – 0.05		
Ni	0.01 – 0.05		
Zn	– 0.1		
Suspended solids	10 – 20		
LID <sub>F</sub>	1 – 2		Dilution factor
LID <sub>D</sub>	2 – 4		
LID <sub>A</sub>	1 – 8		
LID <sub>L</sub>	3 – 16		
LID <sub>EU</sub>	1.5		
* The levels relate to the effluent after biological treatment without dilution, e.g. by mixing with cooling water			

**Table 5.8: BAT for emissions from the biological WWTP**

### 5.2.4.8 Monitoring of the total effluent

Regular monitoring of the total effluent, including performance of the biological WWTP enables the operator of a multipurpose plant to identify problems arising from product changes, individual production campaigns or even individual production batches and to indicate that measures to solve such problems lead to results (for an example, see Section 4.3.8.8). Monitoring of refractory loads, AOX, and heavy metals show if pretreatment strategies were successful (for an example, see Sections 4.3.7.14 and 4.3.7.22). The monitoring frequencies should reflect the operational mode of the production and the frequency of product changes as well as the ratio of buffer volume and residence time in the biological WWTP. For an example concerning monitoring frequencies, see Table 4.86 in Section 4.3.8.21.

**BAT is to regularly monitor the total effluent to and from the biological WWTP measuring at least the parameters given in Table 5.1. (see Section 4.3.8.21).**

#### 5.2.4.8.1 Biomonitoring

Where substances with ecotoxicological potential are handled or produced with or without intention (e.g. production of active pharmaceutical ingredients, biocides, plant health products), biomonitoring is a tool to identify residual acute toxicity in the total effluent instead of tracking an uncertain and possibly wide range of individual substances. Biomonitoring also represents an option to identify inherent problems on a production site which are possibly not as visible as fluctuations in other monitoring data. The biomonitoring frequencies should reflect the operational mode of the production and the frequency of product changes. Where biomonitoring shows that residual toxicity is a concern, the causes of such toxicity should be identified in order to develop and implement measures.

**BAT is to carry out regular biomonitoring of the total effluent after the biological WWTP where substances with ecotoxicological potential are handled or produced with or without intention (for examples, see Sections 4.3.8.18 and 4.3.8.19).**

#### 5.2.4.8.2 Online toxicity monitoring

Where residual toxicity is identified as a concern (e.g. where fluctuations of the performance of the biological WWTP can be related to critical production campaigns), online biomonitoring in combination with online TOC measurement is a tool to identify critical situations early and to enable the operator to react.

**BAT is to apply online toxicity monitoring in combination with online TOC measurement if residual acute toxicity is identified as a concern, for examples see Sections 4.3.8.7 and 4.3.8.20.**

## 5.3 Environmental management

A number of environmental management techniques are determined as BAT. The scope (e.g. level of detail) and nature of the EMS (e.g. standardised or non-standardised) will generally be related to the nature, scale and complexity of the installation, and the range of environmental impacts it may have.

BAT is to implement and adhere to an Environmental Management System (EMS) that incorporates, as appropriate to individual circumstances, the following features: (see Chapter 4)

- definition of an environmental policy for the installation by top management (commitment of the top management is regarded as a precondition for a successful application of other features of the EMS)
- planning and establishing the necessary procedures
- implementation of the procedures, paying particular attention to
  - structure and responsibility
  - training, awareness and competence
  - communication
  - employee involvement
  - documentation
  - efficient process control
  - maintenance programme
  - emergency preparedness and response
  - safeguarding compliance with environmental legislation.
- checking performance and taking corrective action, paying particular attention to
  - monitoring and measurement (*see also the Reference document on Monitoring of Emissions*)
  - corrective and preventive action
  - maintenance of records
  - independent (where practicable) internal auditing in order to determine whether or not the environmental management system conforms to planned arrangements and has been properly implemented and maintained.
- review by top management.

Three further features, which can complement the above stepwise, are considered as supporting measures. However, their absence is generally not inconsistent with BAT. These three additional steps are:

- having the management system and audit procedure examined and validated by an accredited certification body or an external EMS verifier
- preparation and publication (and possibly external validation) of a regular environmental statement describing all the significant environmental aspects of the installation, allowing for year-by-year comparison against environmental objectives and targets as well as with sector benchmarks as appropriate
- implementation and adherence to an internationally accepted voluntary system such as EMAS and EN ISO 14001:1996. This voluntary step could give higher credibility to the EMS. In particular EMAS, which embodies all the above-mentioned features, gives higher credibility. However, non-standardised systems can in principle be equally effective provided that they are properly designed and implemented.



## 6 EMERGING TECHNIQUES

### 6.1 Mixing improvement

#### Description

Most OFCs are manufactured in batch stirred vessels, which are used for blending, reaction and separation (e.g. crystallisation, liquid-liquid extraction). A very wide range of vessel and stirrer designs is available, each having advantages and disadvantages depending on the process requirements. Mixing conditions in a full scale stirred tank are likely to be significantly different to those in a laboratory or pilot vessel, which may have a substantial effect on process performance. The use of inappropriate mixing conditions on a plant may result in:

- a lower than expected yield (leading to more raw material use and more waste)
- a need to use excess reagents
- excess use of solvents (to counteract poor mixing in a vessel)
- excessive energy use (due to over-stirring, inefficient agitator design or excessive batch times)
- poor incorporation of solids into the process, leading to a waste of solid reagents or excessive batch times
- poor transfer of gaseous reagents, leading to excessive gas use
- rejected batches due to product variability.

#### Achieved environmental benefits

These will vary from application to application, but typical examples of mixing improvements have yielded:

- 50 % reduction in chlorine consumption
- 50 % reduction in raw material use; 75 % reduction in waste volume (pigment production)
- 50 % reduction in organic impurities in waste stream (waste treatment)
- 90 % reduction in surfactant use (powder draw-down process)
- 65 % reduction in batch time, and hence energy use (gel manufacturing)
- over-design of a new agitator avoided, resulting in 30 % reduction in power draw (paint plant).

#### Operational data

Ensuring appropriate mixing is used will improve operability of the plant and will help avoid lost batches.

#### Cross-media effects

*None believed likely.*

#### Applicability

Potentially applicable across most OFC processes. Opportunities are greatest when a new plant is being designed, but retrofits can be cost effective for existing plants and processes. Less opportunity is available for multipurpose, multiproduct plants, but consideration of mixing on scale up can lead to the selection of the most appropriate vessel or identification when severe process problems are likely and a retrofit is highly desirable.

### **Economics**

Prevention of problems will be more cost effective than later plant retrofits, loss of production or end-of-pipe treatment of waste.

### **Driving force for implementation**

Improved economics, increased production, improved product quality.

### **References to literature and example plants**

[104, BHR Group, 2005]

## 6.2 Process intensification

### Description

Most OFCs are manufactured in batch stirred vessels, which are used for blending, reaction and separation (eg crystallisation, liquid-liquid extraction). Such technology has the benefit of being well understood and highly flexible. However, as described in Section 6.1, performance is often suboptimal. Even when mixing in stirred vessels is optimised, fundamental limitations on their performance (e.g. rate of mixing and heat transfer) can still mean loss of performance on scale up (see Section 6.1).

Moving from batch to small scale, continuous, intensified reactor technologies has the potential to make step changes in environmental performance. A wide range of such Process Intensification (PI) technologies is available for single and multiphase processes, including:

- static mixer reactors
- ejectors
- combined chemical reactor-heat-exchangers (HEX reactors)
- spinning disk reactors
- oscillatory flow reactors
- ‘higee’ technology.

PI technologies are complementary to microreactor technologies (Section 4.1.4.6), and can be applied where larger production rates are required (10 – 10000 tonnes per year) and the ‘numbering up’ philosophy for microreactors becomes impractical.

### Achieved environmental benefits

These will vary from application to application, but typical examples of environmental benefits from the application of PI are:

- 99 % reduction in impurity levels in a hydrosilylation process resulting in a more valuable product whilst reducing excess reagents by around 20 % and removing requirements for an additional solvent
- >70 % reduction in energy usage (typical figure for a range of processes studied – achieved through substantial reduction in the time spent mixing and the ability to integrate heat)
- >99 % reduction in reactor volume for potentially hazardous processes, leading to inherently safe operations.

Maximum environmental benefits can be achieved through combination of PI with green chemistry (Section 4.1.1), solvent selection (Section 4.1.3), and alternative synthesis and reaction conditions (Section 4.1.4).

### Cross-media effects

*None believed likely.*

### Operational data

Some additional development time may be needed for an intensified, continuous process, and care is needed with start up and shut down procedures. Once operating under steady state conditions, such technologies will provide reliable processes, with minimal manual interventions required and batch to batch variability avoided.

### **Applicability**

PI is ideally suited to inherently fast chemical processes (with reaction times less than a few minutes). This may not be true for many conventionally designed processes, but enhanced chemical conditions can often be utilised which enable PI technologies to be exploited effectively. The existence of solids as the reactant, catalyst or product can cause difficulties in some PI technologies (but this is much less of a problem than with microreactors). Opportunities are highest when a new plant is being designed, but retrofits can be cost effective for existing plants and processes.

PI can be applied to multipurpose, multiproduct plants, through the use of reconfigurable ‘plug and play’ plants.

### **Economics**

Economics will depend on the application, but benefits can arise through improved product quality (and hence value), increased product yield, reduced raw material and solvent use. Capital cost savings for a PI plant are typically in the range of 50 – 70 % compared to a conventional plant.

### **Driving force for implementation**

Improved economics, increased production, improved product quality, improved inherent safety.

### **References to literature and example plants**

[105, Stankiewicz, 2004]

## 6.3 Microwave Assisted Organic Synthesis

### Description

Microwave Assisted Organic Synthesis (MAOS) uses microwave energy to heat and thus drive chemical reactions. Microwave irradiation efficiently heats the materials by a 'microwave dielectric heating' effect. This phenomenon is dependent on the ability of a specific material (solvent or reagent) to absorb microwave energy and convert it to heat. The irradiation produces efficient internal heating by direct coupling of microwave energy with the molecules. The energy of microwave photon is too low to break chemical bonds and therefore microwaves cannot induce chemical reactions.

Microwave heating enables a wide range of reactions to be performed quickly and easily. Among them are allylic alkylations, ring closing metathesis, cycloadditions, C-H bond activation, numerous rearrangements and reactions directed towards combinatorial chemistry using polymer-supported substrates. This technique is able to contain reactions involving superheated solvents. This allows the use of solvents from which it is easy to isolate products.

### Achieved environmental benefits

- higher energy efficiency (related to dramatic enhancement of reaction rates, higher yields, and less by-products)
- possible avoidance of transition metal catalyst and hence avoidance of toxic waste
- excellent control of reaction parameters.

### Cross-media effects

*None believed likely.*

### Operational data

"It appears that the combination of rapid dielectric heating by microwaves with sealed vessel technology (autoclaves) will most likely be the method of choice for performing MAOS in the future" [107, Kappe, 2004].

The choice of solvent is not governed by the boiling point but rather by the dielectric properties of the reaction medium which can be easily tuned by, for example, addition of highly polar materials such as ionic liquids.

### Applicability

Applicable to a number of reaction types. Simple (simplicity of the programming and ease of use) and effective technology.

At the moment, several litres can be processed at a time. Continuous flow reactors are nowadays available for both single- and multimode cavities that allow the preparation of kilograms of materials. However, at present, there are no documented published examples of the use of microwave technology for organic synthesis on a production-scale level above 1000 kg per batch. Several manufacturers of microwave systems are working to transfer the technology from a laboratory scale into process plants.

### **Economics**

- reduced reaction time (minutes vs. hours), higher yield and less by-products
- higher equipment costs (many times higher than those for conventional heating equipment).

### **Driving forces for implementation**

- improved synthesis of fine chemicals.

### **References to literature and example plants**

[107, Kappe, 2004], [93, Leadbeater, 2004]

## 6.4 Constant flux reactor systems

### Description

The concept of ‘constant flux’ can be applied to most heat transfer devices and reactor designs (batch, semi-continuous and continuous). However, constant flux has seen its most advanced development in its application to the continuously stirred tank reactor – the most common type of process equipment to be found in a modern fine chemical/pharmaceutical manufacturing plant.

Constant flux stirred tank reactors use a fundamentally different temperature control philosophy. Whereas conventional stirred tank reactors control process temperatures by regulating the temperature of the heating/cooling jacket, constant flux stirred tank reactors have variable heat transfer areas (see Figure 6.1 below). In the Figure,  $q = U \cdot A \cdot \text{LMTD}$  is the heat transfer equation, where  $q$  = heat added or removed by the heat-exchanger (W),  $U$  = heat transfer coefficient ( $\text{W m}^{-2} \text{K}^{-1}$ ),  $A$  = heat transfer area ( $\text{m}^2$ ) and LMTD = mean temperature difference between jacket and process (K).

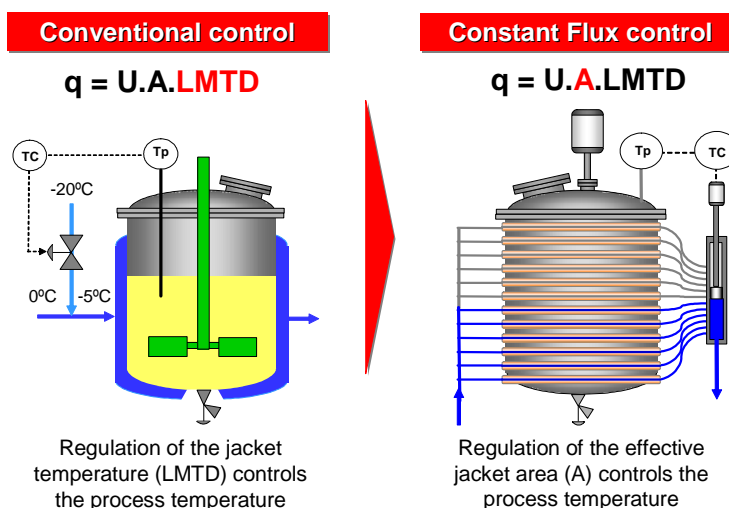

**Figure 6.1: Comparison of conventional temperature control and constant flux control**

The variable area surface is created by breaking the jacket up into multiple independently controlled heat transfer elements. (The feed and return pipes to the individual jacket elements are connected to common manifolds). The outlet manifold is fitted with a motorised piston which is used to regulate the number of heat transfer elements in service.

The use of the area as the primary control parameter together with the use of small heat transfer elements delivers some unique performance capabilities:

- process monitoring of unprecedented accuracy using heat balance calorimetry
- process temperature control that is more accurate, faster and more stable than conventional techniques
- improved process conditions within the vessel
- more efficient utilisation of heat transfer fluid.

### Achieved environmental benefits

Continuous online monitoring (via calorimetry) of the processes delivers the following environmental benefits:

- accurate processes end point detection – delivering improved product yield and reducing waste
- accurate processes end point detection – improving plant utilisation and reducing energy costs associated with unnecessary prolonged batch times
- identification of potential runaway reactions – reducing the associated environmental risks.

An improved process temperature control of constant flux can improve reaction selectivity (and process conditions) and, hence, output quality and yield. A reduction in the amount of waste product is a natural consequence of this.

Finally, constant flux utilises a fundamentally different approach to process temperature control. This delivers the following environmental improvements on the heat transfer fluid system:

- reduction in the pumping energy required to circulate the heat transfer fluid, by over 90 %
- reduction in the absolute heating and cooling energy required to control the heat transfer fluid temperature
- reduction in the inventory of heat transfer fluid required – reducing the consumption of heat transfer fluid.

### Cross-media effects

*None believed likely.*

### Operational data

Constant flux can be operated in the same way as virtually any conventional stirred tank reactor:

- volumetric capacity: from 100 ml to 100000 litres
- material of construction: stainless steel, hastelloy, glass, glass-lined steel and other alloys
- operating pressure: as required
- operating temperature: as required
- U values (the overall heat transfer coefficient) equivalent to, or better than, conventional jacketed batch reactors.

### Applicability

Constant flux can be applied to virtually any batch vessel design on any scale. The designs are suitable for laboratory, pilot and industrial applications. The concept of constant flux can be applied to batch vessels running, e.g. chemical synthesis reactions, crystallisations, polymerisations and fermentations.

Furthermore, the concept of constant flux can be applied to continuous reactors. However, development in this area is at an early stage.



**Economics**

The ability to monitor a process online will allow the process to be continually improved and optimised. This will deliver significant economic advantages in operational plant performance. The quantum of the economic advantage will, however, be determined by the particular process(es) and the nature of the plant employed.

The capital cost of implementing constant flux is often small when compared to the operational benefits achievable.

**Driving force for implementation**

Within the pharmaceutical industry, the FDA's Process and Analytical Technology (PAT) initiative is a key force in driving the adoption of analytical techniques in pharmaceutical manufacturing. Constant flux provides an accurate, simple and versatile analytical tool in the primary manufacturing environment.

More generally, the economic benefits that constant flux can deliver (improved product yield and quality, and reduced operating costs) is driving increasing interest from a broad range of chemical manufacturers across a number of application areas.

**References to literature and example plants**

[109, Ondrey, 2005], [110, A. Desai and R. Pahngli, 2004], [111, Ashe, 2004], [112, Hairston, 2003], [113, Ashe, 2002]



## 7 CONCLUDING REMARKS

### 7.1 Quality of the information exchange

#### Timing of the work

The information exchange on Best Available Techniques for the Manufacture of Organic Fine Chemicals was carried out from 2003 to 2005. It took 25 months to collect the information, to draft this document and to develop this document based on the comments arising from two consultations and the final TWG meeting. Table 7.1 shows the milestones of the work.

Kick-off meeting	26 – 28 May 2003
First draft	February 2004
Second draft	December 2004
Final Technical Working Group meeting	27 – 30 June 2005

**Table 7.1: Timing of the work on the BREF for Organic Fine Chemicals**

#### Sources of information and development of this document

Some reports were elaborated on purpose to provide targeted information for the development of this document. The reports submitted by Germany [15, Köppke, 2000, 50, UBA, 2001], Spain [46, Ministerio de Medio Ambiente, 2003] and CEFIC [18, CEFIC, 2003] can be considered building blocks for the first draft.

A big part of the information was obtained by visiting 28 production sites in Spain, Ireland, France, UK, Finland, Sweden, Hungary, Austria, Switzerland, Germany and Italy [58, Serr, 2003, 91, Serr, 2004], usually organised and accompanied by one or more TWG members. Additionally, a wide variety of other sources provided information and examples of good practices. The sources include Industry and Member State shadow groups, a number of individual companies (this document includes data from 115 reference plants) and the contributions include sources where the author wanted to remain anonymous.

This document was developed based on about 1000 comments to the first draft and about 800 comments to the second draft. Major discussion items at the final meeting were the selection of VOC recovery/abatement techniques, on-site versus off-site biological waste water treatment and the pretreatment of waste water streams.

#### Level of consensus

The information exchange process was successful and a high degree of consensus was reached during and following the final meeting of the Technical Working Group. No split views were recorded. However, it has to be noted that increasing confidentiality concerns represented a considerable obstacle throughout the work.

## 7.2 Recommendations for future work

### Quantified overview to emission and consumption levels in the OFC sector

The environmental key issues in the OFC sector are described in general in Section 1.2. However, Chapter 3 “Current emission and consumption levels” of this document only contains emission levels from individual reference plants and, with the exception of Figure 3.1 and Table 3.6, no concrete data or information were available to provide a more detailed overview to the releases from the OFC sector as a whole. Future work could provide this overview.

### Extending the understanding of the VOC emission situation from OFC plants

OFC production is carried out as batch manufacture in multipurpose plants but also includes dedicated production lines for “larger” volume products with batch, semi-batch or continuous operation. This establishes a highly variable situation and the information exchange showed that a conventional approach to understand the VOC emissions situation can be misleading. Table 7.2 lists relevant subjects.

Subject	Comment
Monitoring and interpretation of emission levels from ducted sources	The high variability of emission volume flows represents a challenge for the interpretation of emission levels. Future work could be based on data arising from BAT in Sections 5.2.1.1.4 and 5.2.1.1.5 about monitoring of emission profiles and continuous monitoring
Diffuse and fugitive emissions	The information exchange did not provide sufficient information to enable an assessment of the role and share of diffuse/fugitive emissions of the total VOC emissions
Unified classification system for VOC compounds	The fact that across Europe different classification systems for emissions to air are in use represented an obstacle for the work on OFC when it came to the differentiation of less and more harmful compounds.

**Table 7.2: Recommendations for future work related to VOC emissions to air**

### Joint pretreatment platforms for OFC waste waters

The information exchange on OFC underlines the importance of the combination of pretreatment of waste water streams and the biological waste water treatment of the total effluent. The treatment with high pressure wet oxidation with O<sub>2</sub> under alkaline conditions on a joint pretreatment platform, as described in Section 4.3.7.4, offers a highly efficient and flexible response to the challenges arising from the waste water streams created on OFC sites (see the BAT in Section 5.2.4), especially where numerous OFC sites are located in the same region. At the same time it offers a solution for the sludge from biological waste water treatment (see also Table 7.3). Future work could focus on a more in depth assessment of the economic aspects of this approach, and its comparison with individual waste water treatment strategies.

## Assessment of formulation processes

Many products from the chemical synthesis like, e.g. dyes/pigments, biocides/plant health products or explosives are given in formulations, mixtures, or standardised suspensions. Such manufacturing facilities can be technically linked to the synthesis unit and are possibly linked to the same rhythm of production campaigns/batch operations. Formulation activities may cause emissions, such as VOCs from residual solvent, particulates from handling, wash-water from rinsing/cleaning or waste water streams from additional separation operations. Future work could build on the information available in Section 2.7.1 and assess formulation processes in more depth.

## Other subjects

In some cases, the information exchange did not provide a sufficient basis for an assessment according to the BAT concept or the related conclusions had to be kept general. Table 7.3 lists these subjects as identified at the final TWG meeting.

Subject	Comment
Treatment of sludges arising from waste water treatment	See, e.g. Sections 4.3.7.4, 4.3.7.22 and 5.2.4.5. Future work could assess different options
Extraction from natural products	Important process for obtaining raw materials from natural products, see Sections 2.7.2 and 4.1.5
Treatment of waste explosives	Frequently carried out on explosives production sites, see Section 2.5.8

**Table 7.3: Subjects with too little information for an assessment within the BAT concept**

## Suggested topics for future R&D work

Most OFCs are manufactured in batch stirred vessels, which are used for blending, reaction and separation (e.g. crystallisation, liquid-liquid extraction). Such technology has the benefit of being well understood and highly flexible. However, performance is often suboptimal (see Section 6.2). A range of alternative process technologies is described in the chapter “Emerging techniques”. Other examples, with their first application on an industrial scale, are given in Chapter 4 amongst the techniques to consider in the determination of BAT (e.g. Section 4.1.4.6). Although these techniques are considered to offer environmental benefits, such statements are usually vague. Future R&D could provide more detailed information especially about environmental benefits, cross-media effects and the applicability of such techniques.

Whole effluent assessment (WEA) has been proposed as a tool to evaluate the effectiveness of waste water treatment. The WEA concept uses bioassays to assess toxicity, persistency and bioaccumulation. Several tests within the WEA toolbox are available and robust, mostly with regard to acute toxicity and bioaccumulation. However, some further work is required on persistency and chronic toxicity and case studies should be carried out to prove the “availability” in the OFC context (see Section 4.3.8.19).

The EC is launching and supporting, through its RTD programmes, a series of projects dealing with clean technologies, emerging effluent treatment and recycling technologies and management strategies. Potentially these projects could provide a useful contribution to future BREF reviews. Readers are therefore invited to inform the EIPPCB of any research results which are relevant to the scope of this document (see also the Preface of this document).



---

**REFERENCES**

- 1 Hunger, K. (2003). "Industrial Dyes", WILEY-VCH, 3-527-30426-6.
- 2 Onken, U., Behr, A. (1996). "Chemische Prozesskunde", Georg Thieme Verlag, 3-527-30864-4.
- 6 Ullmann (2001). "Ullmann's Encyclopedia of Industrial Chemistry", Wiley-VCH.
- 9 Christ, C. E. (1999). "Production-Integrated Environmental Protection and Waste Management in the Chemical Industry", 3-527-28854-6.
- 10 Anastas, P. T., Williamson, T.C. (Eds.) (1996). "Green Chemistry - Designing Chemistry for the Environment", ACS Symposium Series, 0-8412-3399-3.
- 15 Köppke, K.-E., Wokittel, F. (2000). "Forschungsbericht: Untersuchungen von Möglichkeiten medienuebergreifender Emissionsminderungen am Beispiel von Betrieben der Pharma- und Spezialitaetenchemie", 297 65 527 FG III 2.3.
- 16 Winnacker and Kuechler (1982). "Chemische Technologie Band 6", Carl Hanser Verlag, 3-446-13184-1.
- 17 Schönberger, H. (1991). "Zur biologischen Abbaubarkeit im Abwasserbereich. Ist der Zahn-Wellens-Abbauteest der richtige Test ?", Z. Wasser-Abwasser-Forsch., pp. 118 - 128.
- 18 CEFIC (2003). "Best available techniques for producing Organic Fine Chemicals".
- 19 Booth, G. (1988). "The manufacture of organic colorants and intermediates", Society of Dyers and colourists, 0-901956-47-3.
- 20 Bamfield, P. (2001). "The restructuring of the colorant manufacturing industry", Rev. Prog. Color., pp. 1-14.
- 21 EFPIA (2003). "About the industry", EFPIA.
- 22 ECPA (2002). "Ten years of ECPA: 1992 - 2002", European Crop Protection Association, ECPA.
- 23 US EPA (2003). "About Pesticides", US EPA.
- 24 EFRA (2003). "Market Statistics", European Flame Retardant Association.
- 25 Kruse, W. (2001). "Errichtung einer Produktionsanlage zur Herstellung von 7-Aminocephalosporansaeure", BC Biochemie GmbH, Frankfurt, 20028.
- 26 GDCh (2003). "Summary of BUA Stoffberichte".
- 27 OECD (2003). "Introduction to the OECD guidelines for testing of chemicals".
- 28 Loonen, H., Lindgren, F., Hansen, B., Karcher, W., Niemela, J., Hiromatsu, K., Takatsuki, M., Peijnenburg, W., Rorije, E., Struijs, J. (1999). "Prediction of biodegradability from chemical structure: modeling of ready biodegradability test data", Environmental Toxicology and Chemistry, pp. 1763-1768.
- 29 Kaltenmeier, D. (1990). "Abwasserreinigung nach dem Stand der Technik in chemischen Grossbetrieben", Korrespondenz Abwasser, pp. 534-542.

- 30 ESIS (2003). "European Existing Substances Information System", European Chemicals Bureau.
- 31 European Commission (2003). "BREF on common waste water and waste gas treatment / management systems in the chemical sector".
- 32 CEFIC (2003). "Crop protection Agents".
- 33 DECHEMA (1995). "Industrial Waste Water: The Problem of AOX", DECHEMA, 3-926 959-70-3.
- 34 Schwarting, G. (2001). "Für alle Fälle - Zentrale Abgasreinigungsanlage für pharmazeutischen Multi-purpose-Betrieb", Chemie Technik, pp. 54-56.
- 35 CEFIC (2003). "Special considerations surrounding product families: Pharmaceuticals".
- 36 Moretti, E. (2002). "Reduce VOC and HAP Emissions", CEP, pp. 30-40.
- 37 ESIG (2003). "Guide on VOC emissions management".
- 38 Moretti, E. C. (2001). "Practical solutions for reducing volatile organic compounds and hazardous air pollutants", 0-8169-0831-1.
- 39 Bayer Technology Services (2003). "LOPROX®-Niederdruck-Nassoxidation zur Abwasserverreinigung und Schlammbehandlung", Bayer Technology Services.
- 40 Schwalbe, T., Autze, V., Wille, G. (2002). "Chemical Synthesis in Microreactors", Chimia, 56 / 11, pp. 636-346.
- 41 Hiltcher, M., Smits (2003). "Industrial pigging technology", Wiley-VCH, 3-527-30635-8.
- 42 TAA (1994). "Guide for the Identification and Control of Exothermic Chemical Reactions", Technical Committee for Plant Safety (TAA) at the German Federal Ministry of Environment, Nature Conservation and Nuclear Safety.
- 43 Chimia (2000). "Green Chemistry", Chimia, pp. 492-530.
- 44 Hörsch, P., Speck, A., Frimmel, F. (2003). "Combined advanced oxidation and biodegradation of industrial effluents from the production of stilbene-based fluorescent whitening agents", Water Research, pp. 2748 - 2756.
- 46 Ministerio de Medio Ambiente (2003). "Spanish report on BATs in the Organic Fine Chemistry Sector".
- 48 TA Luft (2002). "Erste allgemeine Verwaltungsvorschrift zum Bundesimmissionsschutzgesetz - Technische Anleitung zur Reinhaltung der Luft", Bundesgesetzblatt.
- 49 Anhang 22 (2002). "Anhang 22 zur Abwasserverordnung: Chemische Industrie".
- 50 UBA (2001). "German proposals for BAT for the BREF on common waste water and waste gas treatment in the chemical sector".
- 51 UBA (2004). "Data and comments for subsections "Sulphonation", "Diazotisation" and "Metallisation"".



- 53 UBA (2004). "BREF OFC: Herstellung von Pflanzenschutzmitteln", personal communication.
- 54 Verfahrens u. Umwelttechnik Kirchner (2004). "Abluftkonzept für die hochflexible Produktion organischer Feinchemikalien", Verfahrens u. Umwelttechnik Kirchner, Wischbergstrasse 8, 91332 Heiligenstadt, personal communication.
- 55 CEFIC (2003). "Logical grouping of unit operations and processes".
- 56 Jungblut, H.-D., Schütz, F., BASF Aktiengesellschaft, Ludwigshafen (2004). "Special considerations surrounding product families: Crop Protection Chemicals".
- 57 UBA (2004). "Translated excerpt from Hinweise und Erläuterungen zum Anhang 22 der Abwasserverordnung".
- 58 Serr, B. (2003). "Mission report: site visits in Spain".
- 60 SICOS (2003). "Guide technique de mise en place des schemas de maitrise de emissions dans le secteur de la chimie fine pharmaceutique", SICOS, Ministere de L'Écologie et du Développement Durable, ADEME.
- 61 Martin, M. (2002). "Membrantechnik für scharfe Farben", Chemie Technik, pp. 66-67.
- 62 D1 comments (2004). "TWG's comments on draft 1 OFC".
- 64 European Commission (2005). "BREF on Emissions from Storage".
- 65 Freemantle, M. (2003). "BASF's Smart Ionic Liquid", Chemical and Engineering News, 81/13, pp. 1.
- 66 Riedel (2004). "Ionic Liquids", Sigma-Aldrich.
- 67 UBA (2004). "Data and comments for subsections "chlorination", "alkylation", "condensation" and "pretreatment on production sites for biocides/plant health products"".
- 68 Anonymous (2004). "Comparison of two sites for the Production of insecticides", personal communication.
- 69 Wuthe, S. (2004). "Mikroreaktoren halten Einzug in die Produktion von Feinchemikalien", Chemie Technik, pp. 36-40.
- 70 SW (2002). "Mikroverfahrenstechnik auf dem Weg in die Produktion", Chemie Technik, pp. 46-50.
- 72 EPA, U. (1999). "How to prevent runaway reactions", Case study: Phenol-formaldehyde reaction hazards.
- 73 Gartiser, S., Hafner, C. (2003). "Results of the "Demonstration Program" in Germany. Report to the OSPAR IEG on Whole Effluent Assessment.", FKZ 201 19 304.
- 75 Trenbirth, B. (2003). "Discussion of emissions from an Organic Fine Chemical Manufacturer", Contract Chemicals.
- 76 Rathi, P. (1995). "H-acid: A review and analysis of cleaner production", Chemical Engineering World, XXX./10, pp. 6.

- 78 Boswell, C. (2004). "Microreactors gain wider use as alternative to batch production", Chemical Market Reporter, pp. 8-10.
- 79 Linnhoff (1987). "Process Integration of Batch Processes" AIChE Annual Meeting, *New York*.
- 82 Baumgarten, G., Jakobs, D., Muller, H. (2004). "Behandlung von AOX haltigen Abwasserteilströmen aus pharmazeutischen Produktionsprozessen mit Nanofiltration und Umkehrosiose", Chemie Ingenieur Technik, pp. 321 - 325.
- 83 Gebauer, M., Lorch, H-W. (1995). "Produktionsintegrierte Prozesswasseraufbereitung in der Pharmazeutischen Industrie (Verfahrensvorstellung und erste Betriebserfahrungen)" Colloquium Produktionsintegrierter Umweltschutz - Bremen, .
- 84 Meyer, E. (2004). "Abwasserbehandlung nach dem Stand der Technik am Beispiel eines pharmazeutischen Betriebes" Abwasser aus der chemischen und pharmazeutischen Industrie, .
- 86 Oza, H. (1998). "Options for improvements in H-acid manufacture", Chemical weekly, pp. 151 - 158.
- 88 Falcke (1997). "Biomonitoring of the effluents of the Organic Chemical Industry" Ecotoxicological Evaluation of Waste Water, *Berlin*.
- 89 3V Green Eagle (2004). "Solid-liquid separation", 3V Cogeim, [www.3v-cogeim.com](http://www.3v-cogeim.com).
- 90 3V Green Eagle (2004). "Advanced Technologies for waste water treatment", 3V Cogeim, [www.3v-cogeim.com](http://www.3v-cogeim.com).
- 91 Serr, B. (2004). "Information obtained from site visits in Finland, Sweden, Hungary, Austria, Switzerland, Germany and Italy."
- 92 Collivignarelli, C., Riganti, V., Galessi, R. (1999). "WET OXIDATION - Sperimentazione su Impianti Pilota del Trattamento del Refluo da Produzione di Caprolattame".
- 93 Leadbeater, N. (2004). "Making microwaves", Chemistry World, pp. 38-41.
- 94 O'Driscoll, C. (2004). "Small is bountiful - disposable microreactors bring chemical manufacture to the desktop", Chemistry World, pp. 26-30.
- 95 Up-To-Date Umwelttechnik AG (2005). "ConCat Abluftreinigungsanlagen - Zusatzinformationen", Up-To-Date Umwelttechnik AG.
- 96 Up-To-Date Umwelttechnik AG (2005). "ConCat Abluftreinigung", Up-To-Date Umwelttechnik AG.
- 97 Up-To-Date Umwelttechnik AG (2005). "PLASMACAT Clean air at low cost", Up-To-Date Umwelttechnik AG.
- 98 Up-To-Date Umwelttechnik AG (2005). "PLASMACAT Abluftreinigung - Zusatzinformationen", Up-To-Date Umwelttechnik AG.
- 99 D2 comments (2005). "TWG's comments on draft2 OFC".

- 100 TAA (2000). "Technische Regel für Anlagensicherheit TRAS 410 Erkennen und Beherrschen exothermer chemischer Reaktionen", Bundesanzeiger, 166a/2001.
- 102 VDI (2000). "VDI2440 Emissionsminderung Mineralölraffinerien", VDI.
- 103 European Commission (2005). "BREF on Waste Incineration".
- 104 BHR Group (2005). "Benefits of improving mixing processes".
- 105 Stankiewicz, A., Moulijn, J., Dekker, M. (Eds) (2004). "Re-engineering the chemical processing plant - Process Intensification", 0-8247-4302-4.
- 106 Koppke, K.-E., Wokittel, F. (2000). "Untersuchungen zum Einsatz abwasserloser Produktionsprozesse in der chemisch-pharmazeutischen Industrie", 299 26 306.
- 107 Kappe, C. O. (2004). "Controlled Microwave Heating in Modern Organic Synthesis", Angewandte Chemie International Edition, pp. 6250 - 6284.
- 108 European Commission (2003). "BREF on General Principles of Monitoring".
- 109 Ondrey, G. (2005). "A new process-monitoring tool passes field tests", Chemical Engineering, pp. 15.
- 110 A. Desai and R. Pahnngli (2004). "An Investigation into Constant Flux Transfer for Improved Reaction and Crystallisation", Department of Chemical Engineering, Imperial College.
- 116 Phosgene Panel (2005). "Phosgene Panel", American Chemistry Council.
- 117 TWG 2 comments (2005). "TWG's comments in the final TWG meeting", personal communication.



## 8 GLOSSARY

### 8.1 Abbreviations and explanations

#### A

ADR	European agreement concerning the international carriage of dangerous goods by road
AOX	Adsorbable organic halogen. A measure of the adsorbable organically bound halogens in water. The analytical test consists in adsorbing the organic substances contained in the water sample on activated charcoal (halogen-free). The charcoal is then eluted with sodium nitrate solution to completely remove chloride ions (non-organically bound halogen). Afterwards, the charcoal is burned in a stream of oxygen and the resultant hydrogen chloride is quantitatively determined. Only chlorine, bromine and iodine (not the ecologically important fluorine compounds) are determined with this analytical method. Bromine and iodine are calculated as Cl. The analytical values are expressed as AOX in mg Cl/l of water or mg Cl/g of substance.
API	Active pharmaceutical ingredient
Aquatic toxicity	<p>A measure of the effects of a given pollutant on aquatic life. The most common parameters are:</p> <p>IC<sub>10</sub> = inhibition concentration of bacterial growth (10 % inhibition). Concentrations above the IC<sub>10</sub> value may strongly affect the efficiency of a biological treatment plant or even completely poison the activated sludge.</p> <p>LC<sub>50</sub> = lethal concentration (50 % mortality). It is used for fish and represents the water concentration at which a given substance causes the mortality of 50 % of the population.</p> <p>EC<sub>50</sub> = effect concentration (50 % effect). It is used for particularly sensitive organisms such as daphnia and algae.</p> <p>The level of aquatic toxicity of a given pollutant is defined as follows:</p> <ul style="list-style-type: none"> <li>• highly toxic: &lt;0.1 mg/l</li> <li>• very toxic: 0.1 – 1 mg/l</li> <li>• toxic: 1.0 – 10 mg/l</li> <li>• moderately toxic: 10 – 100 mg/l</li> <li>• non toxic: &gt;100 mg/l.</li> </ul>

#### B

Biodegradability	A measure of the ability of an organic substance to be biologically oxidised by bacteria. It is measured by BOD tests (OECD tests 301 A to F) and relates to the biodegradation mechanisms taking place in biological waste water treatment works. It is usually expressed in % (of the substance).
Bioeliminability	<p>A measure of the ability of an organic substance to be removed from the effluent as a consequence of all elimination mechanisms that can take place in a biological plant (including biodegradation). It is measured by the bio-elimination test OECD 302 B, which determines the total effect of all elimination mechanisms in a biological treatment plant:</p> <ul style="list-style-type: none"> <li>• biodegradation (measured over a long period – up to 28 days – in order to account for the biodegradation of substances that necessitate the development of specially acclimatised bacteria capable of digesting them)</li> <li>• adsorption on activated sludge</li> <li>• stripping of volatile substances</li> <li>• hydrolysis and precipitation processes</li> </ul> <p>It is usually expressed in % (of the substance).</p>

**BOD<sub>5</sub>** Biological oxygen demand within 5 days  
A measure of the oxygen consumed by bacteria to biochemically oxidise organic substances present in water to carbon dioxide and water.  
The higher the organic load, the larger the amount of oxygen consumed. As a result, with high organic concentrations in the effluent, the amount of oxygen in water may be reduced below acceptable levels for aquatic life.  
BOD tests are carried out at 20 °C in dilute solution and the amount of oxygen consumed is determined after 5, 7 or, less commonly, 30 days. The corresponding parameters are called BOD<sub>5</sub>, BOD<sub>7</sub> and BOD<sub>30</sub>.  
The analytical values are usually expressed in:

- mg O<sub>2</sub>/l (effluent) or
- mg O<sub>2</sub>/g (substance).

**BREF** BAT reference documents

### C

---

**CA** Carbon adsorption and disposal

**CAS** Chemical Abstracts Service

**CEEC** Central Eastern European Countries

**CEFIC** European Chemical Industry Council

**CFCs** Chlorofluorocarbons

**CFR** Code of Federal Regulations. The codification of the general and permanent rules published in the Federal Register by the executive departments and agencies of the US Federal Government

**CHF** Swiss Franc

**cGMP** Current good manufacturing practice in manufacturing, processing, packing, or holding of drugs

**CHCs** Chlorinated hydrocarbons

**CIP** Cleaning-in-place

**cmr** carcinogenic, mutagenic, reprotoxic

**COD** Chemical oxygen demand  
A measure of the amount of oxygen required to chemically oxidise organic and inorganic substances in water.  
COD tests are carried out at ca. 150 °C in the presence of a strong oxidant (usually potassium dichromate). To evaluate the oxygen consumption, the amount of chromium VI reduced to chromium III is determined and the obtained value is converted into oxygen equivalent.  
The analytical values are usually expressed in:

- mg O<sub>2</sub>/l (effluent) or
- mg O<sub>2</sub>/g (substance).

**Containment boom** A floating or stationary device composed of plastic, natural or synthetic materials which can be used to contain an array of spills, e.g. petroleum, within or outside a particular area. Booms come in many different shapes, sizes, and styles and can be used on land or on water.

**CP** Mass flowrate multiplied with the specific heat capacity

### D

---

**DeNO<sub>x</sub>** Elimination of nitrogenoxides from waste gases

**DMF** Dimethylformamide

**DEM** German Mark (Deutsche Mark)

---

DMSO	Dimethyl sulfoxide
DOC	Dissolved organic carbon
<b>E</b>	
<hr/>	
EC	European Community
EC <sub>50</sub>	Acute toxicity level The EC <sub>x</sub> procedure uses statistical data analysis where at least five data pairs of concentration and response are needed. The response needs to be between 0 and 100 %. The EC <sub>50</sub> level represents the concentration which causes a measurable negative effect on 50 % of the test population. See also "LID"
ECPA	European Crop Protection Association
EFTA	European Free Trade Association
EHS	Environment, Health and Safety
EIPPCB	European Integrated Pollution Prevention and Control Bureau
ELV	Emission limit value
EMAS	Eco-management and audit scheme
EMPA	Eidgenössische Materialprüfungs- und Forschungsanstalt
EOX	Extractable organic halogen
EPA	Environmental Protection Agency
ESIG	European Solvents Industry Group
ESIS	European Existing Substances Information System
EtO	Ethylene oxide
EU	European Union
EUR	Euro
<b>F</b>	
<hr/>	
FDA	US Federal Drug Administration
FID	Flame ionisation detector
<b>G</b>	
<hr/>	
GDCh	Gesellschaft Deutscher Chemiker
GMO	Genetically modified organism
GMP	Good manufacturing practice
<b>H</b>	
<hr/>	
HHC	Halogenated hydrocarbons
HMX	High Melting eXplosive, also known as Octogen and Cyclotetramethylene tetranitramine
HNS	Hexanitrostilbene
<b>I</b>	
<hr/>	
IBC	Intermediate Bulk Container
IEP	Irish Pound

---

IMS	Industrial methylated spirits
IPPC	Integrated Pollution Prevention and Control
IQ	Installation qualification
ISO	International Organisation for Standardisation
I-TEQ	International toxicity equivalent of dioxins/furans

### L

---

L(CT)	Lethal concentration for a given exposure period
LEL	Lower explosion limit
LID <sub>F,D,A,L,EU</sub>	Lowest ineffective dilution Dilution of the total effluent is carried out until no effects on the test organisms are observed. Test organisms are usually fish (F), daphnia (D), algae (A), luminescent bacteria (L), genotoxicity (EU). The LID testing does not require a concentration – response relationship and thus the test procedure is simpler than in the determination of EC <sub>50</sub> , but no statistical evaluation and confidence limits are available. For carrying out the LID <sub>F</sub> test fish are increasingly replaced by fish eggs, however, the term “LID <sub>F</sub> ” does not change and the levels are well consistent.

### M

---

MAOS	Microwave Assisted Organic Synthesis
MEK	Methyl ethyl ketone
MIBK	Methyl isobutyl ketone
MITI	Ministry of International Trade and Industry, Japan
MTBE	Methyl tertiary butyl ether
MW	Megawatt

### N

---

NC	Nitrocellulose
NCE	New chemical entity
NG	Nitroglycol
nm	Nanometer

### O

---

OECD	Organisation for Economic Co-operation and Development
OFC	Organic fine chemicals
OQ	Operational qualification

### P

---

PAH	Polycyclic aromatic hydrocarbons
PAN	Peroxacyl nitrates
PCB	Polychlorinated biphenyls
PCDD	Polychlorodibenzo dioxins
PCDF	Polychlorodibenzo furans



PEG	Polyethylene glycol
PETN	Pentaerythritol tetranitrate
PI	Process intensification
PLC	Programmable Logic Controller
POP	Persistent organic pollutant
ppm	Parts per million
PTFE	Polytetrafluoro ethylene, better known by the trade name Teflon®
Purgeable CHCs	Purgeable chlorinated hydrocarbons typically include those chlorinated compounds which can be removed from water by stripping. Other techniques for removal of purgeable CHCs from water are rectification, extraction and combinations of these techniques, including stripping.
PV	Process validation
<b>R</b>	
<hr/>	
R&D	Research and development
Refractory organic load	Part of the organic load in a waste water stream that is not bioeliminable according to inherent bioeliminability testing, e.g. Zahn-Wellens test.
R-phrases	R-phrases are standard phrases indicating the special risk arising from the dangers involved in using the dangerous substance. The wording of the R-phrases is laid down in Annex III of the Directive 67/548/EEC on the approximation of laws, regulations and administrative provisions relating to the classification, packaging and labelling of dangerous substances.
R40	Limited evidence of a carcinogenic effect (see also "R-phrases" above)
R45	May cause cancer (see also "R-phrases" above)
R46	May cause heritable genetic damage (see also "R-phrases" above)
R49	May cause cancer by inhalation (see also "R-phrases" above)
R60	May impair fertility (see also "R-phrases" above)
R61	May cause harm to the unborn child (see also "R-phrases" above)
RTD	Research, technology and development
<b>S</b>	
<hr/>	
SCAS	Semi-continuous activated sludge
SCR	Selective catalytic reduction
SNCR	Selective non-catalytic reduction
SME	Small or medium sized enterprise
SOP	Standard Operating Procedure
<b>T</b>	
<hr/>	
T+	Very toxic (compound) by inhalation, in contact with skin and if swallowed
TAA	Technical Committee for Plant Safety at the German Federal Ministry of Environment, Nature Conservation and Nuclear Safety
TATB	1,3,5-Triamino-2,4,6-trinitrobenzene
TDS	Total dissolved solids

## Glossary

---

THF	Tetrahydrofuran
TMT	Trimercaptotriazine
TNT	2,4,6-Trinitrotoluene
TO	Thermal oxidiser
TOC	Total organic carbon
TPP	Triphenylphosphine
TPPO	Triphenylphosphine oxide
TWG	Technical Working Group

### U

---

UBA	Umweltbundesamt
UK	United Kingdom
US	United States of America
USD	US Dollar
UV	Ultraviolet

### V

---

VOC	Volatile Organic Compound
VSS	Volatile Suspended Solids
v/v	Volume by volume ratio

### W

---

WEA	Whole Effluent Assessment Assessment of ecotoxicological effects (persistence, bioaccumulation and toxicity) in the whole effluent sample. Two procedures are commonly used to express toxicity levels: EC <sub>50</sub> or LID.
WESP	Wet Electrostatic Precipitator
wt-%	Weight percentage
w/w	Weight by weight ratio
WWTP	Waste Water Treatment Plant

## 8.2 Dictionary

English	Deutsch	Français	Español
abatement	Minderung	réduction, suppression	limpieza
activated carbon	Aktivkohle	charbon actif	carbón activo
active ingredient	Wirksubstanz	ingrédient actif	componente activo
AOX	AOX	AOX	AOX
batch	Charge	lot	batch
batch production	chargenweise Herstellung	production en discontinue	producción en batch
BOD	BSB	DBO	DBO
broth	Brühe	bouillon	caldo
by-products	Nebenprodukte	sous-produits	subproducto
COD	CSB	DCO	DQO
condenser	Rückflusskühler	condenseur	condensador
degradability	Abbaubarkeit	dégradabilité	degradabilidad
distillation residue	Distillationsrückstand	résidu de distillation	residuo de destilación
effluent	Abwasser	effluent	aguas residuales
emission inventory	Emissionskataster	inventaire des émissions	catastro de emisiones
exhaust gas	Abgas	rejet gazeux	emisión gaseosa
fire fighting water	Löschwasser	eau d'incendie	agua contraincendio
heavy metal	Schwermetall	métaux lourds	metal pesado
intermediate	Zwischenprodukt	produit intermédiaire	producto intermedio
isomer	Isomer	isomère	isómero
mass balance	Massenbilanz	bilan matière	balance de materias
mother liquor	Mutterlauge	eaux mères	aguas madres
organic load	organische Fracht	charge organique	carga orgánica
phase	Phase	phase	fase
pigging technology	Molchtechnik	technique de raclage des canalisations	transporte y limpieza simultaneous
point source (emission)	Emissionsquelle	point source	punto de emisión
precipitation	Fällung	precipitation	precipitación
pretreatment	Vorbehandlung	pré-traitement	pre-tratamiento
recovery	Rückgewinnung	récupération	recuperación
rinsing/cleaning water	Spülwasser	rinçage/eau de rinçage	aguas de limpieza
salting out	Aussalzen	précipitation par ajout de sel	precipitar con sal
scrubber	Wäscher	épurateur (laveur de gaz)	lavador de gases
stirred-tank reactor	Rührkesselreaktor	reacteur sous agitation	reactor de tanque agitado
stripping	Strippen	stripage, separation	agotamiento
thermal oxidation	thermische Nachverbrennung	oxidation thermique	oxidación termica
TOC	TOC	DBO	COT
total effluent	Gesamtabwasser	effluents totaux	efluente total
VOC	VOC	COV	COV
wash-water	Waschwasser	eau de lavage	aguas de lavado
waste water stream	Abwasserteilstrom	écoulement des eaux usées	corriente segregada
work-up	Aufarbeitung	finition, fabrication	procesar
yield	Ausbeute	rendement	rendimiento



## 9 ANNEXES

### 9.1 Description of reference plants

Table 9.1 lists the reference plants from which information or data were used in this document, as far as the information source named a particular plant. Other information or data used arise from contributions where no particular plant was named. The sequence of the numbering has no particular significance, but the number can be used to identify a certain reference plant throughout this document. The letters after the number indicate the production spectrum as follows:

	Number of appearances
A API	51
B Biocides and/or plant health products	14
D Dyes and/or pigments	13
E Explosives	8
F Flavours and/or fragrances	6
I Intermediates	73
L Large integrated multiproduct site	2
O Optical brighteners	2
V Vitamins	3
X Other OFC	27

Plant	Production
001A,I	API, intermediates
002A	API
003F	Fragrances
004D,O	Optical brighteners, dyes
005A	API
006A,I	API, intermediates
007I	Intermediates
008A,I	API, intermediates
009A,B,D	API, active plant protection agents, dyes
010A,B,D,I,X	API, active plant protection agents, dyes, intermediates, further organic fine chemicals, sulphuric acid, acetaldehyde, C1-CHC
011X	Light stabilisers, antioxidants, corrosion inhibitors, additives, stabilisers
012X	Organic and inorganic specialities
013A,V,X	API, vitamins, organic fine chemicals
014V,I	Vitamins, intermediates
015D,I,O,B	Dyes, intermediates, optical brighteners, antimicrobica
016A,I	API, intermediates
017A,I	API, intermediates
018A,I	API, intermediates
019A,I	API, intermediates
020A,I	API, intermediates
021B,I	Intermediates, biocides

<b>Plant</b>	<b>Production</b>
022F	Flavours/fragrances
023A,I	API, intermediates
024A,I	API, intermediates
025A,I	API, Intermediates
026E	Explosives
027A,I	API, intermediates
028A,I	API, intermediates
029A,I	API, intermediates
030A,I	API, intermediates
031A,I	API, intermediates
032A,I	API, intermediates
033L	Large integrated multiproduct site
034A,I	API, Intermediates
035D	Dyes
036L	Large integrated multiproduct site
037A,I	API, intermediates
038F	Fragrances
039A,I	API, intermediates
040A,B,I	API, biocides, intermediates
041A,I	API, intermediates
042A,I	API, intermediates
043A,I	API, intermediates
044E	Explosives
045E	Explosives
046I,X	Intermediates, custom synthesis
047B	Biocides, plant health products
048A,I	API, intermediates
049A,I	API, intermediates
050D	Dyes and pigments
051I,X	Intermediates, multiproduct
052I,X	Intermediates, multiproduct
053D,X	Pigments, printing auxiliaries
054A,I	API, intermediates
055A,I	API, intermediates
056X	Textile auxiliaries
057F	Fragrances/flavours
058B	Herbicides, molluscicides
059B,I	Biocides, intermediates, multiproduct
060D,I	Dyes, intermediates
061X	Speciality surfactants
062E	Explosives

<b>Plant</b>	<b>Production</b>
063E	Explosives
064E	Explosives
065A,I	API, intermediates
066I	Intermediates
067D,I	Dyes and pigments, intermediates
068B,D,I	Dyes, plant health products, intermediates
069B	Plant health products
070X	Speciality surfactants
071I,X	Speciality surfactants
072I,X	Additives
073F	Fragrances, flavours
074F	Fragrances, flavours
075I,X	Intermediates, other organic fine chemicals
076X	Speciality surfactants
077X,I	Additives, speciality surfactants, intermediates
078X,I	Intermediates, other organic fine chemicals
079D	Dyes and pigments
080I	Intermediates
081A,I	API, intermediates
082A,I	API, intermediates
083A,I	API, intermediates
084A,I	API, intermediates
085B	Biocides and plant health products, intermediates
086A,I	API, intermediates
087I	Intermediates
088I,X	Textile chemicals, detergents, additives, intermediates
089A,I	API, intermediates
090A,I,X	API, intermediates, food additives
091D,I	Dyes, intermediates for dyes
092B,I	Insecticides, herbicides, fungicides, intermediates
093A,I	API, intermediates
094I	Intermediates
095A,I	API, intermediates
096A,I	API, intermediates
097I	Intermediates
098E	Explosives
099E	Explosives
100A,I	API, intermediates
101D,I,X	Dyes, intermediates, other organic fine chemicals
102X	Not provided
103A,I,X	API, intermediates, analytical reagents, other organic fine chemicals

---

<b>Plant</b>	<b>Production</b>
104X	Speciality rubbers and additives
105X	Not provided
106A,I	API, intermediates
107X	Not provided
108B,I	Agrochemicals, intermediates
109A,V	API, intermediates
110B	Agrochemicals
111A,I	API, intermediates
112X	Additives
113I,X	Surfactants for cosmetics
114A,I	API, intermediates
115A,I	API, intermediates

**Table 9.1: Description of reference plants**