

JRC SCIENCE FOR POLICY REPORT

Best Available Techniques (BAT) Reference Document for Waste Incineration

*Industrial Emissions Directive
2010/75/EU
(Integrated Pollution
Prevention and Control)*

Frederik Neuwahl, Gianluca Cusano,
Jorge Gómez Benavides, Simon Holbrook,
Serge Roudier

2019



Best Available Techniques (BAT) Reference Document for Waste Incineration

Industrial Emissions Directive 2010/75/EU
Integrated Pollution Prevention and Control

Authors:

Frederik NEUWAHL
Gianluca CUSANO
Jorge GÓMEZ BENAVIDES
Simon HOLBROOK
Serge ROUDIER

2019

EUR 29971 EN

This publication is a Science for Policy report by the Joint Research Centre, the European Commission's in-house science service. It aims to provide evidence-based scientific support to the European policy-making process. The scientific output expressed does not imply a policy position of the European Commission. Neither the European Commission nor any person acting on behalf of the Commission is responsible for the use which might be made of this publication.

Contact information

Name: European IPPC Bureau

Address: Joint Research Centre, Edificio Expo c/ Inca Garcilaso 3, E-41092 Seville, Spain

E-mail: JRC-B5-EIPPCB@ec.europa.eu

Tel.: +34 95 4488 284

JRC Science Hub

<https://ec.europa.eu/jrc>

Legal Notice

Under the Commission Decision of 12 December 2011 on the Re-use of Commission Documents (2011/833/EU), the present BREF document is subject to free re-use, except for parts covered by any third-party rights which may be present in the document (such as images, tables, data, written material, or similar, the rights to which need to be acquired separately from their respective rights-holders for further use). The European Commission is not liable for any consequence stemming from the re-use of this publication. Any re-use is subject to the acknowledgement of the source and non-distortion of the original meaning or message.

JRC118637

EUR 29971 EN

PDF ISBN 978-92-76-12993-6 ISSN 1831-9424 doi:10.2760/761437

Luxembourg: Publications Office of the European Union, 2019.

© European Union, 2019

How to cite this report: Frederik Neuwahl, Gianluca Cusano, Jorge Gómez Benavides, Simon Holbrook, Serge Roudier; *Best Available Techniques (BAT) Reference Document for Waste Incineration*; EUR 29971 EN; doi:10.2760/761437

All images © European Union 2019, except: Cover picture credits in clockwise order starting from the left: 1. External economiser and dry flue gas cleaning system, Torino Termovalorizzatore © TRM – Trattamento Rifiuti Metropolitan; 2. Turbine-generator sets recovering Brussels W-t-E plant energy © Archives CNIM - Laurent Photo; 3. Plate exchangers and pumps feeding District Heating network, Lyon-South W-t-E plant © Archives CNIM Grand Lyon, CNIM – Studio 36; 4. Grab and operator arm, Torino Termovalorizzatore © TRM – Trattamento Rifiuti Metropolitan; 5. Furnace fire, Sysav WtE Plant © CEWEP

Title Best Available Techniques (BAT) Reference Document for Waste Incineration

Abstract

The Best Available Techniques (BAT) Reference Document (BREF) for Waste Incineration is part of a series of documents presenting the results of an exchange of information between EU Member States, the industries concerned, non-governmental organisations promoting environmental protection, and the Commission, to draw up, review and – where necessary – update BAT reference documents as required by Article 13(1) of Directive 2010/75/EU on Industrial Emissions (the Directive). This document is published by the European Commission pursuant to Article 13(6) of the Directive.

The BREF for Waste Incineration covers the disposal or recovery of waste in waste incineration plants and waste co-incineration plants, and the disposal or recovery of waste involving the treatment of slags and/or bottom ashes from the incineration of waste.

Important issues for the implementation of Directive 2010/75/EU in the waste incineration (WI) sector include emissions to air, emissions to water, and the efficiency of the recovery of energy and of materials from the waste. Chapter 1 provides general information on the WI sector. Chapter 2 provides information on the common processes and general techniques that are applied across the WI sector for: the pre-treatment, storage and handling of different types of waste; the thermal treatment; energy recovery; flue-gas cleaning; waste water treatment; and the treatment of solid residues. Chapter 3 reports the current ranges of the emission and consumption levels reported in the WI sector. Techniques to consider in the determination of BAT (i.e. techniques that are widely applied in the WI sector) are reported in Chapter 4. Chapter 5 presents the BAT conclusions as defined in Article 3(12) of the Directive. Chapter 6 presents information on 'emerging techniques' as defined in Article 3(14) of the Directive. Chapter 7 contains concluding remarks and recommendations for future work.

Acknowledgements

This report was produced by the European Integrated Pollution Prevention and Control Bureau (EIPPCB) at the European Commission's Joint Research Centre – Directorate B: Growth and Innovation under the supervision of Serge Roudier (Head of the EIPPCB) and Luis Delgado Sancho (Head of the Circular Economy and Industrial Leadership Unit).

The authors of this BREF were Frederik Neuwahl, Gianluca Cusano, Jorge Gómez Benavides, and Simon Holbrook.

This report was drawn up in the framework of the implementation of the Industrial Emissions Directive (2010/75/EU) and is the result of the exchange of information provided for in Article 13 of the Directive.

Major contributors of information were:

- among EU Member States: Austria, Belgium, Czechia, Denmark, Finland, France, Germany, Italy, the Netherlands, Poland, Spain, Sweden and the United Kingdom;
- among EEA countries: Norway;
- among industry: CEWEP (Confederation of European Waste-to-Energy Plants), ESWET (European Suppliers of Waste to Energy Technology), FEAD (European Federation for Waste Management and Environmental Services), HWE (Hazardous Waste Europe), Eurits (European Union for Responsible Incineration and Treatment of Special Waste), CEFIC (European Chemical Industry Council);
- among environmental Non-Governmental Organisations: EEB (European Environmental Bureau).

Other contributors to the review process were Hungary, Ireland, Malta, Portugal, Romania, Cembureau (the European Cement Association), CEPI (Confederation of European Paper Industries), ESPP (European Sustainable Phosphorus Platform), Eurelectric (the Union of the Electricity Industry), Eurometaux (European Non-ferrous Metals Association), Euroheat & Power, FIR (Fédération Internationale du Recyclage), IMA Europe (the European Industrial Minerals Association), Orgalim (Europe's Technology Industries).

The whole EIPPCB team provided contributions and peer reviewing.

This report was edited by Anna Atkinson and formatted by Carmen Ramírez Martín.

This document is one from the series of foreseen documents listed below:

Reference Document on Best Available Techniques (BREF)	Code
Ceramic Manufacturing Industry	CER
Common Waste Water and Waste Gas Treatment/Management Systems in the Chemical Sector	CWW
Common Waste Gas Management and Treatment Systems in the Chemical Sector	WGC
Emissions from Storage	EFS
Energy Efficiency	ENE
Ferrous Metals Processing Industry	FMP
Food, Drink and Milk Industries	FDM
Industrial Cooling Systems	ICS
Intensive Rearing of Poultry and Pigs	IRPP
Iron and Steel Production	IS
Large Combustion Plants	LCP
Large Volume Inorganic Chemicals – Ammonia, Acids and Fertilisers Industries	LVIC-AAF
Large Volume Inorganic Chemicals – Solids and Others Industry	LVIC-S
Large Volume Organic Chemical Industry	LVOC
Management of Tailings and Waste-rock in Mining Activities	MTWR
Manufacture of Glass	GLS
Manufacture of Organic Fine Chemicals	OFC
Non-ferrous Metals Industries	NFM
Production of Cement, Lime and Magnesium Oxide	CLM
Production of Chlor-alkali	CAK
Production of Polymers	POL
Production of Pulp, Paper and Board	PP
Production of Speciality Inorganic Chemicals	SIC
Production of Wood-based Panels	WBP
Refining of Mineral Oil and Gas	REF
Slaughterhouses and Animals By-products Industries	SA
Smitheries and Foundries Industry	SF
Surface Treatment of Metals and Plastics	STM
Surface Treatment Using Organic Solvents including Wood and Wood Products Preservation with Chemicals	STS
Tanning of Hides and Skins	TAN
Textiles Industry	TXT
<i>Waste Incineration</i>	<i>WI</i>
Waste Treatment	WT
Reference Document (REF)	
Economics and Cross-media Effects	ECM
Monitoring of Emissions to Air and Water from IED Installations	ROM

Electronic versions of draft and finalised documents are publicly available and can be downloaded from <http://eippcb.jrc.ec.europa.eu>.

PREFACE

1. Status of this document

Unless otherwise stated, references to 'the Directive' in this document refer to Directive 2010/75/EU of the European Parliament and of the Council on industrial emissions (integrated pollution prevention and control) (Recast).

The original best available techniques (BAT) reference document (BREF) on Waste Incineration was adopted by the European Commission in 2006. This document is the result of a review of that BREF. The review commenced in May 2014.

This BAT reference document for Waste Incineration forms part of a series presenting the results of an exchange of information between EU Member States, the industries concerned, non-governmental organisations promoting environmental protection and the Commission, to draw up, review and, where necessary, update BAT reference documents as required by Article 13(1) of the Directive. This document is published by the European Commission pursuant to Article 13(6) of the Directive.

As set out in Article 13(5) of the Directive, the Commission Implementing Decision 2019/2010/EU on the BAT conclusions contained in Chapter 5 was adopted on 12 November 2019 and published on 3 December 2019¹.

2. Participants in the information exchange

As required in Article 13(3) of the Directive, the Commission has established a forum to promote the exchange of information, which is composed of representatives from Member States, the industries concerned and non-governmental organisations promoting environmental protection (Commission Decision of 16 May 2011 establishing a forum for the exchange of information pursuant to Article 13 of the Directive 2010/75/EU on industrial emissions (2011/C 146/03), OJ C 146, 17.05.2011, p. 3).

Forum members have nominated technical experts constituting the technical working group (TWG) that was the main source of information for drafting this document. The work of the TWG was led by the European IPPC Bureau (of the Commission's Joint Research Centre).

3. Structure and contents of this document

Chapters 1 and 2 provide general information on the industrial sector concerned and on the industrial processes used within the sector.

Chapter 3 provides data and information concerning the environmental performance of installations within the sector, and in operation at the time of writing, in terms of current emissions, the consumption and nature of raw materials, water consumption, use of energy and the generation of waste.

Chapter 4 describes in more detail the techniques to prevent or, where this is not practicable, to reduce the environmental impact of installations in this sector that were considered in determining the BAT. This information includes, where relevant, the environmental performance levels (e.g. emission and consumption levels) which can be achieved by using the techniques, the associated monitoring and the costs and the cross-media issues associated with the techniques.

¹ [OJ L 312, 03.12.2019, p. 55.](#)

Chapter 5 presents the BAT conclusions as defined in Article 3(12) of the Directive.

Chapter 6 presents information on 'emerging techniques' as defined in Article 3(14) of the Directive.

Concluding remarks and recommendations for future work are presented in Chapter 7.

4. Information sources and the derivation of BAT

This document is based on information collected from a number of sources, in particular through the TWG that was established specifically for the exchange of information under Article 13 of the Directive. The information has been collated and assessed by the European IPPC Bureau (of the Commission's Joint Research Centre) who led the work on determining BAT, guided by the principles of technical expertise, transparency and neutrality. The work of the TWG and all other contributors is gratefully acknowledged.

The BAT conclusions have been established through an iterative process involving the following steps:

- identification of the key environmental issues for the Waste Incineration sector;
- examination of the techniques most relevant to address these key issues;
- identification of the best environmental performance levels, on the basis of the data available in the European Union and worldwide;
- examination of the conditions under which these environmental performance levels were achieved, such as costs, cross-media effects, and the main driving forces involved in the implementation of the techniques;
- selection of the best available techniques (BAT), their associated emission levels (and other environmental performance levels) and the associated monitoring for this sector according to Article 3(10) of, and Annex III to, the Directive.

Expert judgement by the European IPPC Bureau and the TWG has played a key role in each of these steps and the way in which the information is presented here.

Where available, economic data have been given together with the descriptions of the techniques presented in Chapter 4. These data give a rough indication of the magnitude of the costs and benefits. However, the actual costs and benefits of applying a technique may depend greatly on the specific situation of the installation concerned, which cannot be evaluated fully in this document. In the absence of data concerning costs, conclusions on the economic viability of techniques are drawn from observations on existing installations.

5. Review of BAT reference documents (BREFs)

BAT is a dynamic concept and so the review of BREFs is a continuing process. For example, new measures and techniques may emerge, science and technologies are continuously developing and new or emerging processes are being successfully introduced into the industries. In order to reflect such changes and their consequences for BAT, this document will be periodically reviewed and, if necessary, updated accordingly.

6. Contact information

All comments and suggestions should be made to the European IPPC Bureau at the Joint Research Centre (JRC) at the following address:

European Commission
JRC Directorate B – Growth and Innovation
European IPPC Bureau
Edificio Expo
c/Inca Garcilaso, 3
E-41092 Seville, Spain
Telephone: +34 95 4488 284
E-mail: JRC-B5-EIPPCB@ec.europa.eu
Internet: <http://eippcb.jrc.ec.europa.eu>

Best Available Techniques Reference Document for Waste Incineration

PREFACE	I
SCOPE	XXVII
1 GENERAL INFORMATION ON WASTE INCINERATION	1
1.1 PURPOSE OF INCINERATION AND BASIC CONCEPTS	1
1.2 OVERVIEW OF WASTE INCINERATION IN EUROPE.....	3
1.3 PLANT SIZES.....	7
1.4 WASTE COMPOSITION AND PROCESS DESIGN	8
1.5 KEY ENVIRONMENTAL ISSUES	10
1.5.1 Emissions to air and water	10
1.5.2 Production of residues and recoverable materials	11
1.5.3 Process noise	12
1.5.4 Energy production and consumption.....	13
1.5.5 Consumption of raw materials and energy.....	14
1.6 ECONOMIC INFORMATION.....	15
2 APPLIED PROCESSES AND TECHNIQUES	21
2.1 OVERVIEW AND INTRODUCTION.....	21
2.2 PRE-TREATMENT, STORAGE AND HANDLING TECHNIQUES	23
2.2.1 Municipal solid waste and similar (MSW).....	23
2.2.1.1 Collection and pre-treatment outside the MSW incineration plant	23
2.2.1.2 Municipal solid waste pre-treatment within the incineration plant	24
2.2.1.3 Waste delivery and storage	24
2.2.1.3.1 Waste control.....	24
2.2.1.3.2 Bunker.....	25
2.2.2 Hazardous waste.....	25
2.2.2.1 Waste acceptance	27
2.2.2.2 Storage	28
2.2.2.2.1 Storage of solid hazardous waste	28
2.2.2.2.2 Storage of pumpable hazardous waste	29
2.2.2.2.3 Storage of containers and tank containers	29
2.2.2.3 Feeding and pre-treatment.....	29
2.2.3 Sewage sludge	31
2.2.3.1 Composition of sewage sludge.....	31
2.2.3.2 Pre-treatment of sewage sludge.....	32
2.2.3.2.1 Physical dewatering.....	32
2.2.3.2.2 Drying	32
2.2.3.2.3 Sludge digestion	33
2.2.4 Clinical waste	33
2.2.4.1 Nature and composition of clinical wastes	33
2.2.4.2 Handling, pre-treatment and storage of clinical waste	34
2.3 THE THERMAL TREATMENT STAGE.....	35
2.3.1 Grate incinerators	37
2.3.1.1 Waste feeder.....	38
2.3.1.1.1 Addition of sewage sludge to a municipal waste incinerator	38
2.3.1.1.2 Addition of clinical waste to a municipal waste incinerator.....	39
2.3.1.2 Incineration grate	41
2.3.1.2.1 Rocking grates.....	42
2.3.1.2.2 Reciprocating grates	42
2.3.1.2.3 Travelling grates.....	42
2.3.1.2.4 Roller grates	43

2.3.1.3	Bottom ash discharger	43
2.3.1.4	Incineration chamber and boiler	44
2.3.1.5	Incineration air feeding.....	46
2.3.1.6	Incineration temperature, residence time and oxygen content.....	47
2.3.1.7	Auxiliary burners.....	47
2.3.2	Rotary kilns.....	47
2.3.2.1	Rotary kiln with post-combustion chamber for hazardous waste incineration	49
2.3.3	Fluidised beds	51
2.3.3.1	Stationary (or bubbling) fluidised bed incineration for sewage sludge.....	53
2.3.3.2	Circulating fluidised bed (CFB) for sewage sludge.....	55
2.3.3.3	Spreader-stoker furnace	56
2.3.3.4	Rotating fluidised bed.....	56
2.3.4	Pyrolysis and gasification systems	57
2.3.4.1	Introduction to gasification and pyrolysis.....	57
2.3.4.2	Gasification.....	58
2.3.4.3	Pyrolysis	59
2.3.4.3.1	Example of a pyrolysis process.....	61
2.3.4.4	Combination processes	62
2.3.4.4.1	Pyrolysis-combustion.....	62
2.3.4.4.2	Pyrolysis-gasification.....	64
2.3.4.4.3	Gasification-combustion	66
2.3.5	Other techniques	69
2.3.5.1	Incineration chambers for liquid and gaseous wastes	69
2.3.5.2	Incineration of liquid and gaseous chlorinated wastes with HCl recovery	70
2.3.5.3	Incineration of chlorinated liquid wastes with chlorine recycling	72
2.3.5.4	Waste water incineration	73
2.3.5.5	Plasma processes	75
2.4	THE ENERGY RECOVERY STAGE	78
2.4.1	Introduction and general principles	78
2.4.2	External factors affecting energy efficiency	79
2.4.2.1	Waste type and nature.....	79
2.4.2.2	Influence of plant location on energy recovery	80
2.4.2.3	Factors taken into account when selecting the design of the energy cycle	81
2.4.3	Energy efficiency of waste incinerators.....	82
2.4.3.1	Energy inputs to waste incinerators	82
2.4.3.2	Energy outputs from waste incinerators	83
2.4.4	Applied processes for improving energy recovery	83
2.4.4.1	Waste feed pre-treatment	83
2.4.4.2	Boilers and heat transfer	84
2.4.4.2.1	Corrosion in boilers	86
2.4.4.3	Combustion air preheating.....	87
2.4.4.4	Water-cooled grates	88
2.4.4.5	Flue-gas condensation	88
2.4.4.6	Heat pumps	88
2.4.4.6.1	Compressor-driven heat pumps	89
2.4.4.6.2	Absorption heat pumps	89
2.4.4.6.3	Open heat pumps	89
2.4.4.6.4	Example data of different heat pumps	89
2.4.4.7	Flue-gas recirculation	90
2.4.4.8	Recovery of the heat used for reheating flue-gases to the operating temperature of FGC devices	90
2.4.4.9	Steam-water cycle improvements: effect on efficiency and other aspects.....	91
2.5	APPLIED FLUE-GAS CLEANING AND CONTROL SYSTEMS.....	92
2.5.1	Summary of the application of FGC techniques.....	92
2.5.2	Overview of overall combined FGC system options	94

2.5.3	Techniques for the reduction of dust emissions	94
2.5.3.1	Electrostatic precipitators	95
2.5.3.2	Wet electrostatic precipitators	95
2.5.3.3	Condensation electrostatic precipitators	95
2.5.3.4	Ionisation wet scrubbers	96
2.5.3.5	Bag filters	97
2.5.3.6	Cyclones and multi-cyclones	99
2.5.3.7	Venturi scrubbers	100
2.5.4	Techniques for the reduction of acid gas (e.g. HCl, HF and SO _x) emissions .	100
2.5.4.1	Wet processes	101
2.5.4.2	Semi-wet processes	103
2.5.4.3	Dry processes	104
2.5.4.4	Direct desulphurisation	105
2.5.4.5	Selection of alkaline reagent	105
2.5.5	Techniques for the reduction of emissions of oxides of nitrogen	107
2.5.5.1	Primary techniques for NO _x reduction.....	108
2.5.5.1.1	Air supply, gas mixing and temperature control	108
2.5.5.1.2	Flue-gas recirculation	109
2.5.5.1.3	Oxygen injection	109
2.5.5.1.4	Staged combustion	109
2.5.5.1.5	Natural gas injection (reburn).....	109
2.5.5.1.6	Injection of water into furnace/flame	109
2.5.5.2	Secondary techniques for NO _x reduction.....	109
2.5.5.2.1	Selective non-catalytic reduction (SNCR) process.....	110
2.5.5.2.2	Selective catalytic reduction (SCR) process.....	113
2.5.6	Techniques for the reduction of mercury emissions	114
2.5.6.1	Primary techniques	114
2.5.6.2	Secondary techniques	114
2.5.7	Techniques for the reduction of emissions of other metals.....	116
2.5.8	Techniques for the reduction of emissions of organic carbon compounds	116
2.5.8.1	Adsorption on activated carbon reagents in an entrained flow system	117
2.5.8.2	SCR systems	117
2.5.8.3	Catalytic filter bags	117
2.5.8.4	Reburning of carbon adsorbents.....	117
2.5.8.5	Use of carbon-impregnated plastics for PCDD/F adsorption	118
2.5.8.6	Static or moving bed filters	118
2.5.8.7	Rapid cooling of flue-gases.....	119
2.5.9	Reduction of greenhouse gases (CO ₂ , N ₂ O).....	119
2.5.9.1	Prevention of nitrous oxide (N ₂ O) emissions.....	119
2.6	WASTE WATER TREATMENT TECHNIQUES	121
2.6.1	Design principles for waste water control.....	121
2.6.2	Influence of flue-gas cleaning systems on waste water.....	122
2.6.3	Processing of waste water from wet flue-gas cleaning systems	122
2.6.3.1	Physico-chemical treatment	123
2.6.3.2	Application of sulphides.....	124
2.6.3.3	Application of membrane technology	124
2.6.3.4	Stripping of ammonia.....	124
2.6.3.5	Separate treatment of waste water from the first and last steps of the scrubbing system	125
2.6.3.6	Anaerobic biological treatment (conversion of sulphates into elementary sulphur)	125
2.6.3.7	Evaporation systems for process waste water	126
2.6.3.7.1	In-line evaporation	126
2.6.3.7.2	Separate evaporation	127
2.6.3.8	Stripping or evaporation of hydrochloric acid.....	128

2.6.4	Waste water treatment at hazardous waste incinerators.....	128
2.7	SOLID RESIDUE TREATMENT TECHNIQUES	131
2.7.1	Types of solid residues	131
2.7.1.1	Residues arising directly from the incineration process	131
2.7.1.2	Residues arising from the FGC system.....	132
2.7.2	Treatment and recycling of solid residues arising directly from the incineration process	133
2.7.3	Treatments applied to flue-gas cleaning residues	135
2.8	SAFETY DEVICES AND MEASURES	136
3	CURRENT EMISSION AND CONSUMPTION LEVELS.....	139
3.1	INTRODUCTION.....	140
3.1.1	Substance partitioning in the waste incineration outlet streams	141
3.1.2	Examples of dioxin balance for MSWI	143
3.1.3	Composition of raw flue-gas in waste incineration plants.....	144
3.2	EMISSIONS TO AIR	147
3.2.1	Substances emitted to air	147
3.2.2	Emissions to air from waste incineration plants	153
3.2.2.1	Emissions to air from the incineration of municipal solid waste and other non- hazardous waste	157
3.2.2.2	Emissions to air from the incineration of sewage sludge.....	186
3.2.2.3	Emissions to air from the incineration of hazardous waste.....	202
3.2.2.4	Emissions to air from the incineration of clinical waste	219
3.3	EMISSIONS TO WATER	221
3.3.1	Volumes of waste water arising from flue-gas cleaning.....	221
3.3.2	Other potential sources of waste water from waste incineration plants.....	221
3.3.3	Plants free of process water releases.....	223
3.3.4	Plants with waste water discharges.....	223
3.4	SOLID RESIDUES	244
3.4.1	Mass streams of solid residues.....	244
3.4.2	Solid residues' composition and leachability	244
3.4.3	Incineration bottom ash/slag treatment.....	256
3.4.3.1	Mass streams.....	257
3.4.3.2	Emissions to air	260
3.4.3.3	Emissions to water.....	261
3.4.3.4	Energy consumption	263
3.5	ENERGY CONSUMPTION AND PRODUCTION.....	269
3.5.1	Energy efficiency calculation for waste incineration plants	270
3.5.2	Data on the recovery of energy from waste	273
3.5.2.1	Electricity recovery data	274
3.5.2.2	Energy (heat or heat and electrical) recovery data.....	275
3.5.2.3	Boiler efficiency data.....	276
3.5.3	Data on the consumption of energy by the process	277
3.6	NOISE	284
3.7	OTHER RESOURCES USED	285
3.7.1	Water.....	285
3.7.2	Other consumables and fuels	285
3.7.2.1	Neutralisers	286
3.7.2.2	NO _x removal agents	286
3.7.2.3	Fuel oil and natural gas.....	287
3.7.2.4	Merchant hazardous waste incinerator plant survey data	287

4	TECHNIQUES TO CONSIDER IN THE DETERMINATION OF BAT	289
4.1	ORGANISATIONAL TECHNIQUES TO IMPROVE ENVIRONMENTAL PERFORMANCE.....	290
4.1.1	Environmental management systems (EMS)	290
4.1.2	Ensure continuous operation of the WI plant.....	294
4.2	OPERATIONAL TECHNIQUES TO IMPROVE ENVIRONMENTAL PERFORMANCE.....	296
4.2.1	Quality control of incoming wastes.....	296
4.2.1.1	Establishment of plant input limitations and identification of key risks	296
4.2.1.2	Communication with waste suppliers to improve incoming waste quality control	298
4.2.1.3	Control of waste feed quality on the incinerator site.....	299
4.2.1.4	Checking, sampling and testing of incoming wastes.....	300
4.2.1.5	Detectors for radioactive materials.....	302
4.2.2	Waste storage	303
4.2.2.1	Sealed surfaces, controlled drainage and weatherproofing	304
4.2.2.2	Sufficient storage capacity	305
4.2.2.3	Extraction of air from storage areas for odour, dust and diffuse emissions control	307
4.2.2.4	Segregation of waste types for safe processing.....	308
4.2.2.5	Use of fire detection and control systems	310
4.2.3	Pre-treatment of incoming waste, waste transfer and loading.....	311
4.2.3.1	Pre-treatment, blending and mixing of wastes	311
4.2.3.2	Direct injection of liquid and gaseous wastes	314
4.3	THERMAL PROCESSING	315
4.3.1	Use of flow modelling.....	319
4.3.2	Design to increase turbulence in the secondary combustion area	320
4.3.3	Selection and use of suitable combustion control systems and parameters	321
4.3.4	Primary and secondary air supply and distribution optimisation	326
4.3.5	Preheating of primary and secondary air.....	328
4.3.6	Replacement of part of the secondary air with recirculated flue-gas	330
4.3.7	Use of oxygen-enriched air	331
4.3.8	Higher temperature incineration (slagging)	334
4.3.9	Increase of the waste burnout.....	336
4.3.10	Reduction of grate riddlings	338
4.3.11	Use of low gas velocities in the furnace and inclusion of empty passes before the boiler convection section.....	339
4.3.12	Determination of the calorific value of the waste and its use as a combustion control parameter.....	340
4.4	TECHNIQUES TO INCREASE ENERGY RECOVERY	342
4.4.1	Optimisation of overall energy efficiency and energy recovery	342
4.4.2	Reduction of flue-gas volume	348
4.4.3	Reduction of overall process energy consumption.....	349
4.4.4	Selection of turbine	351
4.4.5	Increased steam parameters and application of special materials to decrease corrosion in boilers.....	353
4.4.6	Reduction of condenser pressure (i.e. improve vacuum)	356
4.4.7	Optimisation of boiler design	358
4.4.8	Use of an integral furnace-boiler.....	360
4.4.9	Use of a platen-type superheater	360
4.4.10	Low-temperature flue-gas heat exchangers.....	362
4.4.11	Use of flue-gas condensation scrubbers	364
4.4.12	Use of heat pumps to increase heat recovery	367

4.4.13	Special configurations of the water/steam cycle with external power plants ..	369
4.4.14	Effective cleaning of the convection bundles	370
4.5	FLUE-GAS CLEANING AND AIR EMISSION PREVENTION TECHNIQUES.....	373
4.5.1	Factors to consider when selecting flue-gas cleaning systems	373
4.5.1.1	General factors.....	373
4.5.1.2	Energy optimisation.....	373
4.5.1.3	Overall optimisation and the ‘whole system’ approach.....	374
4.5.1.4	Technique selection for new or existing installations	374
4.5.2	Techniques to reduce dust emissions.....	374
4.5.2.1	Pre-dedusting stage before other flue-gas treatments	375
4.5.2.2	Downstream dedusting	378
4.5.3	Techniques to reduce acid gas emissions.....	381
4.5.3.1	Wet scrubbing systems	381
4.5.3.2	Semi-wet scrubbing systems.....	385
4.5.3.3	Dry FGC systems.....	389
4.5.3.4	Addition of wet scrubbing as a flue-gas polishing system after other FGC techniques	391
4.5.3.5	Recirculation of FGC residues in the FGC system	393
4.5.3.6	Direct addition of alkaline reagents to the waste (direct desulphurisation)	395
4.5.3.7	Boiler injection of alkaline reagents (high-temperature injection)	396
4.5.3.8	Combination of semi-wet absorber and dry injection system	397
4.5.3.9	Use of acid gas monitoring for FGC process optimisation	398
4.5.4	Techniques to reduce nitrogen oxide emissions	400
4.5.4.1	Low-NO _x burners for liquid wastes.....	400
4.5.4.2	Replacement of secondary air with recirculated flue-gas	401
4.5.4.3	Selective non-catalytic reduction (SNCR).....	401
4.5.4.4	Selective catalytic reduction (SCR).....	404
4.5.4.5	SCR by catalytic filter bags	409
4.5.5	Techniques to reduce organic compounds including PCDD/F and PCB emissions.....	411
4.5.5.1	Primary techniques for prevention or reduction of organic compounds including PCDD/F and PCBs	411
4.5.5.2	Prevention of reformation of PCDD/F in the FGC system	411
4.5.5.3	Destruction of PCDD/F using SCR	413
4.5.5.4	Destruction of PCDD/F using catalytic filter bags	414
4.5.5.5	Adsorption of PCDD/F by injection of activated carbon or of other adsorbents ..	416
4.5.5.6	Fixed-bed adsorption of PCDD/F	417
4.5.5.7	Use of carbon-impregnated materials for PCDD/F adsorption in wet scrubbers ..	419
4.5.5.8	Use of carbon slurries in wet scrubbers	421
4.5.6	Techniques to reduce mercury emissions	422
4.5.6.1	Low pH wet scrubbing and additives injection.....	422
4.5.6.2	Activated carbon injection for mercury adsorption	424
4.5.6.3	Use of flue-gas condenser for flue-gas polishing.....	426
4.5.6.4	Chlorite injection for elemental mercury control.....	428
4.5.6.5	Addition of hydrogen peroxide to wet scrubbers.....	429
4.5.6.6	Boiler bromine addition	430
4.5.6.7	Fixed-bed adsorption of mercury	432
4.5.6.8	Fixed Sorbent Polymer Catalyst (SPC) systems	432
4.5.7	Techniques to reduce emissions of other substances	433
4.5.7.1	Use of specific reagents for iodine and bromine reduction.....	433
4.6	WASTE WATER TREATMENT AND CONTROL.....	436
4.6.1	Application of waste-water-free flue-gas cleaning techniques	436
4.6.2	Dry bottom ash handling.....	437
4.6.3	Use of boiler drain water	440
4.6.4	Recirculation of effluents to the process instead of discharge.....	441

4.6.5	Segregation of waste water streams and separate treatment, depending on the pollutant content.....	443
4.6.6	Application of physico-chemical treatment to the effluent from the wet flue-gas cleaning system and other contaminated streams	444
4.6.7	Stripping of wet scrubber waste water containing ammonia.....	445
4.6.8	Separation of mercury using ion exchange	446
4.6.9	Separate treatment of effluents arising from different wet scrubbing stages ..	447
4.6.10	Recovery of hydrochloric acid from wet scrubber effluents	448
4.6.11	Recovery of gypsum from wet scrubber effluent.....	449
4.6.12	Crystallisation	450
4.7	TREATMENT TECHNIQUES FOR SOLID RESIDUES.....	453
4.7.1	Segregation of the bottom ash from flue-gas cleaning residues.....	454
4.7.2	Bottom ash screening/sieving and crushing	455
4.7.3	Separation of metals from bottom ash.....	456
4.7.4	Bottom ash treatment using ageing	458
4.7.5	Bottom ash treatment using dry treatment systems.....	460
4.7.6	Bottom ash treatment using wet treatment systems	462
4.7.7	Techniques to reduce emissions to air from the treatment of incineration slags and bottom ashes	467
4.7.8	Waste water treatment.....	468
4.8	NOISE.....	469
5	BEST AVAILABLE TECHNIQUES (BAT) CONCLUSIONS FOR WASTE INCINERATION	471
	SCOPE	471
	DEFINITIONS	472
	ACRONYMS.....	474
	GENERAL CONSIDERATIONS	475
5.1	BAT CONCLUSIONS	478
5.1.1	Environmental management systems	478
5.1.2	Monitoring.....	479
5.1.3	General environmental and combustion performance.....	484
5.1.4	Energy efficiency	488
5.1.5	Emissions to air	491
5.1.5.1	Diffuse emissions	491
5.1.5.2	Channelled emissions.....	493
5.1.5.2.1	Emissions of dust, metals and metalloids	493
5.1.5.2.2	Emissions of HCl, HF and SO ₂	494
5.1.5.2.3	Emissions of NO _x , N ₂ O, CO and NH ₃	495
5.1.5.2.4	Emissions of organic compounds.....	496
5.1.5.2.5	Emissions of mercury.....	498
5.1.6	Emissions to water	499
5.1.7	Material efficiency	502
5.1.8	Noise	503
5.2	DESCRIPTIONS OF TECHNIQUES	504
5.2.1	General techniques	504
5.2.2	Techniques to reduce emissions to air.....	504
5.2.3	Techniques to reduce emissions to water.....	506
5.2.4	Management techniques.....	507
6	EMERGING TECHNIQUES	509

6.1	REHEATING OF TURBINE STEAM.....	509
6.2	OIL SCRUBBER FOR THE REDUCTION OF POLYHALOGENATED AROMATICS AND POLYAROMATIC HYDROCARBONS (PAHs) IN THE FLUE-GASES FROM INCINERATION PLANTS	511
6.3	FLAMELESS PRESSURISED OXYCOMBUSTION.....	513
6.4	PHOSPHORUS RECOVERY FROM SEWAGE SLUDGE INCINERATION ASHES	516
7	CONCLUDING REMARKS AND RECOMMENDATIONS FOR FUTURE WORK	519
8	ANNEXES	523
8.1	COSTS OF SOME AIR EMISSIONS MONITORING SYSTEMS	523
8.2	ENERGY EFFICIENCY CALCULATION EXAMPLES	524
8.2.1	Gross electrical efficiency	524
8.2.2	Gross energy efficiency	526
8.2.3	Intermediate cases: gross electrical efficiency and gross energy efficiency determined jointly	529
8.3	EXAMPLE OF A MULTI-CRITERIA ASSESSMENT USED FOR THE SELECTION OF FGC SYSTEMS	532
8.4	LIST OF EUROPEAN WASTE INCINERATION PLANTS THAT PARTICIPATED IN THE 2016 DATA COLLECTION	534
8.5	LIST OF EUROPEAN BOTTOM ASH TREATMENT PLANTS THAT PARTICIPATED IN THE 2016 DATA COLLECTION	556
8.6	DAILY AND YEARLY AVERAGE EMISSION LEVELS ACHIEVED BY THE WASTE INCINERATION PLANTS REPORTING CONTINUOUSLY MONITORED EMISSIONS IN THE 2016 DATA COLLECTION: DETAILED GRAPHS.....	559
8.7	HALF-HOURLY AND MONTHLY AVERAGE EMISSION LEVELS ACHIEVED BY THE WASTE INCINERATION PLANTS REPORTING CONTINUOUSLY MONITORED EMISSIONS IN THE 2016 DATA COLLECTION: DETAILED GRAPHS	609
8.8	EMISSION LEVELS ACHIEVED BY THE WASTE INCINERATION PLANTS REPORTING PERIODICALLY MONITORED EMISSIONS IN THE 2016 DATA COLLECTION: DETAILED GRAPHS.....	663
8.9	COMPARISON OF PCDD/F EMISSION LEVELS MEASURED BY SHORT-TERM AND LONG-TERM SAMPLING AT 142 WASTE INCINERATION REFERENCE LINES IN BELGIUM AND FRANCE	706
	GLOSSARY.....	709
I.	ISO COUNTRY CODES	710
II.	MONETARY UNITS	711
III.	UNIT PREFIXES, NUMBER SEPARATORS AND NOTATIONS.....	712
IV.	UNITS AND MEASURES	713
V.	CHEMICAL ELEMENTS	714
VI.	CHEMICAL FORMULAE COMMONLY USED IN THIS DOCUMENT	715
VII.	ACRONYMS.....	716
VIII.	DEFINITIONS.....	719
	REFERENCES.....	723

List of figures

Figure 1.1:	Municipal waste incineration capacity per capita in 2014	6
Figure 1.2:	Energy production by municipal waste incinerators in Europe in 1999	13
Figure 2.1:	Example layout of a municipal solid waste incineration plant with a wet FGC system	21
Figure 2.2:	Examples of hazardous waste pre-treatment systems used at some merchant HWIs	30
Figure 2.3:	Grate, furnace and heat recovery stages of an example municipal waste incineration plant	37
Figure 2.4:	Examples of the stages of a clinical waste loading system used at a municipal waste incinerator	40
Figure 2.5:	Different grate types	41
Figure 2.6:	Example of a ram-type bottom ash discharger used at a grate incinerator	43
Figure 2.7:	Example of an incineration chamber	44
Figure 2.8:	Various furnace designs with differing direction of the flue-gas and the waste flow	45
Figure 2.9:	Schematic of a rotary kiln incineration system	48
Figure 2.10:	Rotary (drum-type) kiln with post-combustion chamber	49
Figure 2.11:	Example of a rotary (drum-type) kiln plant for hazardous waste incineration	50
Figure 2.12:	Schematic diagram showing pre-treatment of MSW prior to fluidised bed combustion	52
Figure 2.13:	Main components of a stationary/bubbling fluidised bed	54
Figure 2.14:	Main components of a circulating fluidised bed	56
Figure 2.15:	Representation of a packed bed and current flow gasifier	59
Figure 2.16:	Pyrolysis plant for municipal waste treatment	60
Figure 2.17:	Process scheme of ATM's pyrolysis unit	62
Figure 2.18:	Pyrolysis on a grate with directly connected high-temperature combustion	63
Figure 2.19:	Example of a clinical waste pyrolysis-incineration plant, ZAVIN, Netherlands	64
Figure 2.20:	Schematic diagram of a push pyrolyser (example shown operated by Thermostelect)	66
Figure 2.21:	Combined fluidised bed gasification and high-temperature combustion process	67
Figure 2.22:	Shaft furnace for integrated waste gasification and ash melting	68
Figure 2.23:	Typical design of an incineration chamber for liquid and gaseous wastes	70
Figure 2.24:	Diagram of a plant for HCl extraction from residual gases and liquid halogenated wastes	71
Figure 2.25:	Process scheme of a chlorine recycling unit operated by AkzoNobel	72
Figure 2.26:	Example of a waste water incinerator with a waste water evaporation (concentration) unit	73
Figure 2.27:	Process scheme of a caustic water treatment plant operated by AVR	75
Figure 2.28:	Graph showing recorded variation in waste LHV at a MSWI over 4 years	80
Figure 2.29:	Illustration of individual heat surface areas in a steam generator	84
Figure 2.30:	Basic boiler flow systems	85
Figure 2.31:	Overview of various boiler systems: horizontal, combination and vertical	86
Figure 2.32:	Overview of potential combinations of FGC systems	94
Figure 2.33:	Operating principle of an electrostatic precipitator	95
Figure 2.34:	Condensation electrostatic precipitator	96
Figure 2.35:	An example of a bag filter	98
Figure 2.36:	Diagram of a two-stage wet scrubber with upstream dedusting	102
Figure 2.37:	Operating principle of a spray absorber	103
Figure 2.38:	Schematic diagram of a dry FGC system with reagent injection into the FG duct and downstream bag filtration	104
Figure 2.39:	Temperature dependence of various NO _x formation mechanisms in waste incineration ..	108
Figure 2.40:	SNCR operating principle	110
Figure 2.41:	Relationship between NO _x reduction, production, ammonia slip and reaction temperature for the SNCR process	111
Figure 2.42:	SCR operating principle	114
Figure 2.43:	Relationship between fraction of mercury present in elemental form and the raw gas' chloride content at a hazardous waste incineration plant	115
Figure 2.44:	Process scheme for physico-chemical treatment of waste water from a wet flue-gas cleaning system	123
Figure 2.45:	In-line evaporation of waste water from wet scrubbing	126
Figure 2.46:	Separate evaporation of scrubber effluent from wet scrubbing	127
Figure 2.47:	Overview of applied waste water treatment systems at merchant HWIs	129
Figure 2.48:	Example of a waste water treatment facility in the merchant HWI sector	130
Figure 3.1:	Continuously monitored HCl emissions to air from reference lines incinerating predominantly MSW	158
Figure 3.2:	Continuously monitored HCl emissions to air from reference lines incinerating predominantly ONHW	158

Figure 3.3:	Periodically monitored HF emissions to air from reference lines incinerating predominantly MSW	160
Figure 3.4:	Continuously monitored HF emissions to air from reference lines incinerating predominantly MSW	160
Figure 3.5:	Periodically monitored HF emissions to air from reference lines incinerating predominantly ONHW	161
Figure 3.6:	Continuously monitored HF emissions to air from reference lines incinerating predominantly ONHW	161
Figure 3.7:	Continuously monitored SO ₂ emissions to air from reference lines incinerating predominantly MSW	163
Figure 3.8:	Continuously monitored SO ₂ emissions to air from reference lines incinerating predominantly ONHW	163
Figure 3.9:	Continuously monitored dust emissions to air from reference lines incinerating predominantly MSW	165
Figure 3.10:	Continuously monitored dust emissions to air from reference lines incinerating predominantly ONHW	165
Figure 3.11:	Continuously monitored NO _x emissions to air from reference lines incinerating predominantly MSW	167
Figure 3.12:	Continuously monitored NO _x emissions to air from reference lines incinerating predominantly ONHW	167
Figure 3.13:	Periodically monitored NH ₃ emissions to air from reference lines incinerating predominantly MSW	169
Figure 3.14:	Continuously monitored NH ₃ emissions to air from reference lines incinerating predominantly MSW	169
Figure 3.15:	Periodically monitored NH ₃ emissions to air from reference lines incinerating predominantly ONHW	170
Figure 3.16:	Continuously monitored NH ₃ emissions to air from reference lines incinerating predominantly ONHW	170
Figure 3.17:	Continuously monitored TVOC emissions to air from reference lines incinerating predominantly MSW	172
Figure 3.18:	Continuously monitored TVOC emissions to air from reference lines incinerating predominantly ONHW	172
Figure 3.19:	Continuously monitored CO emissions to air from reference lines incinerating predominantly MSW	174
Figure 3.20:	Continuously monitored CO emissions to air from reference lines incinerating predominantly ONHW	174
Figure 3.21:	Periodically monitored PCDD/F emissions to air from reference lines incinerating predominantly MSW	176
Figure 3.22:	Periodically monitored PCDD/F emissions to air from reference lines incinerating predominantly ONHW	176
Figure 3.23:	Periodically monitored mercury emissions to air from reference lines incinerating predominantly MSW	179
Figure 3.24:	Continuously monitored mercury emissions to air from reference lines incinerating predominantly MSW: daily and yearly emission levels	179
Figure 3.25:	Continuously monitored mercury emissions to air from reference lines incinerating predominantly MSW: half-hourly emission levels.....	180
Figure 3.26:	Continuously monitored mercury emissions to air from reference lines incinerating predominantly MSW: monthly emission levels	180
Figure 3.27:	Periodically monitored mercury emissions to air from reference lines incinerating predominantly ONHW	181
Figure 3.28:	Continuously monitored mercury emissions to air from reference lines incinerating predominantly ONHW: daily and yearly emission levels	181
Figure 3.29:	Continuously monitored mercury emissions to air from reference lines incinerating predominantly ONHW: half-hourly emission levels.....	182
Figure 3.30:	Continuously monitored mercury emissions to air from reference lines incinerating predominantly ONHW: monthly emission levels	182
Figure 3.31:	Periodically monitored Sb+As+Cr+Co+Cu+Pb+Mn+Ni+V emissions to air from reference lines incinerating predominantly MSW	184
Figure 3.32:	Periodically monitored Sb+As+Cr+Co+Cu+Pb+Mn+Ni+V emissions to air from reference lines incinerating predominantly ONHW	184
Figure 3.33:	Periodically monitored Cd+Tl emissions to air from reference lines incinerating predominantly MSW	185

Figure 3.34:	Periodically monitored Cd+Tl emissions to air from reference lines incinerating predominantly ONHW.....	186
Figure 3.35:	Continuously monitored HCl emissions to air from reference lines incinerating predominantly SS	187
Figure 3.36:	Periodically monitored HF emissions to air from reference lines incinerating predominantly SS	188
Figure 3.37:	Continuously monitored HF emissions to air from reference lines incinerating predominantly SS	188
Figure 3.38:	Continuously monitored SO ₂ emissions to air from reference lines incinerating predominantly SS	189
Figure 3.39:	Continuously monitored dust emissions to air from reference lines incinerating predominantly SS	191
Figure 3.40:	Continuously monitored NO _x emissions to air from reference lines incinerating predominantly SS	192
Figure 3.41:	Continuously monitored NH ₃ emissions to air from reference lines incinerating predominantly SS	193
Figure 3.42:	Continuously monitored TVOC emissions to air from reference lines incinerating predominantly SS	194
Figure 3.43:	Continuously monitored CO emissions to air from reference lines incinerating predominantly SS	195
Figure 3.44:	Periodically monitored PCDD/F emissions to air from reference lines incinerating predominantly SS	196
Figure 3.45:	Periodically monitored mercury emissions to air from reference lines incinerating predominantly SS	198
Figure 3.46:	Continuously monitored mercury emissions to air from reference lines incinerating predominantly SS: daily and yearly emission levels	199
Figure 3.47:	Continuously monitored mercury emissions to air from reference lines incinerating predominantly SS: half-hourly emission levels	199
Figure 3.48:	Continuously monitored mercury emissions to air from reference lines incinerating predominantly SS: monthly emission levels.....	200
Figure 3.49:	Periodically monitored Sb+As+Cr+Co+Cu+Pb+Mn+Ni+V emissions to air from reference lines incinerating predominantly SS	201
Figure 3.50:	Periodically monitored Cd+Tl emissions to air from reference lines incinerating predominantly SS	202
Figure 3.51:	Continuously monitored HCl emissions to air from reference lines incinerating predominantly HW	203
Figure 3.52:	Periodically monitored HF emissions to air from reference lines incinerating predominantly HW	204
Figure 3.53:	Continuously monitored HF emissions to air from reference lines incinerating predominantly HW	204
Figure 3.54:	Continuously monitored SO ₂ emissions to air from reference lines incinerating predominantly HW	205
Figure 3.55:	Continuously monitored dust emissions to air from reference lines incinerating predominantly HW	206
Figure 3.56:	Continuously monitored NO _x emissions to air from reference lines incinerating predominantly HW	207
Figure 3.57:	Periodically monitored NH ₃ emissions to air from reference lines incinerating predominantly HW	208
Figure 3.58:	Continuously monitored NH ₃ emissions to air from reference lines incinerating predominantly HW	209
Figure 3.59:	Continuously monitored TVOC emissions to air from reference lines incinerating predominantly HW	210
Figure 3.60:	Continuously monitored CO emissions to air from reference lines incinerating predominantly HW	211
Figure 3.61:	Periodically monitored PCDD/F emissions to air from reference lines incinerating predominantly HW	212
Figure 3.62:	Periodically monitored mercury emissions to air from reference lines incinerating predominantly HW	214
Figure 3.63:	Continuously monitored mercury emissions to air from reference lines incinerating predominantly HW: daily and yearly emission levels	215
Figure 3.64:	Continuously monitored mercury emissions to air from reference lines incinerating predominantly HW: half-hourly emission levels.....	215

Figure 3.65:	Continuously monitored mercury emissions to air from reference lines incinerating predominantly HW: monthly emission levels	216
Figure 3.66:	Periodically monitored Sb+As+Cr+Co+Cu+Pb+Mn+Ni+V emissions to air from reference lines incinerating predominantly HW	217
Figure 3.67:	Periodically monitored Cd+Tl emissions to air from reference lines incinerating predominantly HW	218
Figure 3.68:	Total suspended solid emissions to water and abatement techniques applied	230
Figure 3.69:	Mercury emissions to water and abatement techniques applied	231
Figure 3.70:	Antimony emissions to water and abatement techniques applied	232
Figure 3.71:	Arsenic emissions to water and abatement techniques applied	233
Figure 3.72:	Cadmium emissions to water and abatement techniques applied	234
Figure 3.73:	Chromium emissions to water and abatement techniques applied	235
Figure 3.74:	Copper emissions to water and abatement techniques applied	236
Figure 3.75:	Lead emissions to water and abatement techniques applied	237
Figure 3.76:	Molybdenum emissions to water and abatement techniques applied	238
Figure 3.77:	Nickel emissions to water and abatement techniques applied	239
Figure 3.78:	Thallium emissions to water and abatement techniques applied	240
Figure 3.79:	Zinc emissions to water and abatement techniques applied	241
Figure 3.80:	Total organic carbon emissions to water and abatement techniques applied	242
Figure 3.81:	PCDD/F emissions to water and abatement techniques applied	243
Figure 3.82:	TOC content in untreated incineration slags and bottom ashes (1/2)	265
Figure 3.83:	TOC content in untreated incineration slags and bottom ashes (2/2)	266
Figure 3.84:	LOI of untreated incineration slags and bottom ashes (1/2)	267
Figure 3.85:	LOI of untreated incineration slags and bottom ashes (2/2)	268
Figure 3.86:	System boundary used for the calculation of the energy efficiency	271
Figure 3.87:	Gross electrical efficiency of plants incinerating predominantly municipal solid waste, other non-hazardous waste and hazardous wood waste (1/3)	278
Figure 3.88:	Gross electrical efficiency of plants incinerating predominantly municipal solid waste, other non-hazardous waste and hazardous wood waste (2/3)	279
Figure 3.89:	Gross electrical efficiency of plants incinerating predominantly municipal solid waste, other non-hazardous waste, and hazardous wood waste (3/3)	280
Figure 3.90:	Gross energy efficiency of waste incineration plants	281
Figure 3.91:	Boiler efficiency of plants incinerating predominantly hazardous waste	282
Figure 3.92:	Boiler efficiency of plants incinerating predominantly sewage sludge	283
Figure 4.1:	Continuous improvement in an EMS model	290
Figure 4.2:	Example of the components of a furnace control system	323
Figure 4.3:	Example of the input, control, and output parameters of a furnace control system	323
Figure 4.4:	Schematic diagram of a platen-type superheater	361
Figure 4.5:	Pollution control and additional heat recovery by condensation of flue-gas water vapour at the Högdalen waste-fired CHP plant	366
Figure 4.6:	Typical design of a semi-wet FGC system	385
Figure 4.7:	Diagram of a SCR system downstream of a non-wet FGC system showing typical heat exchange and temperature profiles	407
Figure 4.8:	Diagram of a SCR system downstream of a wet FGC system showing additional heat exchange and temperature profiles	408
Figure 4.9:	Scheme of a dry bottom ash discharge system	438
Figure 4.10:	Flowsheet of crystallisation applied at three waste incineration plants in Denmark	451
Figure 4.11:	Flowsheet of an example IBA treatment process with some mechanical separation stages used for the treatment of bottom ash	453
Figure 4.12:	Effect of ageing on the leachability of selected metals: (left) effect on pH; (right) leaching as a function of pH	459
Figure 4.13:	Flow diagram of a bottom ash wet treatment system	463
Figure 6.1:	Example of the reheating of steam	509
Figure 6.2:	Schematic of a waste incineration plant with a downstream oil scrubber for dioxin deposition	511
Figure 8.1:	Schematic diagram of the separation of the steam system of the waste incineration plant in two parts	529
Figure 8.2:	Daily and yearly average emission levels for continuously monitored HCl emissions to air from reference lines incinerating predominantly MSW (1/3)	559
Figure 8.3:	Daily and yearly average emission levels for continuously monitored HCl emissions to air from reference lines incinerating predominantly MSW (2/3)	560
Figure 8.4:	Daily and yearly average emission levels for continuously monitored HCl emissions to air from reference lines incinerating predominantly MSW (3/3)	561

Figure 8.98: Half-hourly average emission levels for continuously monitored SO ₂ emissions to air from reference lines incinerating predominantly HW	655
Figure 8.99: Half-hourly average emission levels for continuously monitored dust emissions to air from reference lines incinerating predominantly HW	656
Figure 8.100: Half-hourly average emission levels for continuously monitored NO _x emissions to air from reference lines incinerating predominantly HW	657
Figure 8.101: Half-hourly average emission levels for continuously monitored NH ₃ emissions to air from reference lines incinerating predominantly HW	658
Figure 8.102: Half-hourly average emission levels for continuously monitored TVOC emissions to air from reference lines incinerating predominantly HW	659
Figure 8.103: Half-hourly average emission levels for continuously monitored CO emissions to air from reference lines incinerating predominantly HW	660
Figure 8.104: Half-hourly average emission levels for continuously monitored Hg emissions to air from reference lines incinerating predominantly HW	661
Figure 8.105: Monthly average emission levels for continuously monitored Hg emissions to air from reference lines incinerating predominantly HW	662
Figure 8.106: Emission levels for periodically monitored HF emissions to air from reference lines incinerating predominantly MSW (1/2)	663
Figure 8.107: Emission levels for periodically monitored HF emissions to air from reference lines incinerating predominantly MSW (2/2)	664
Figure 8.108: Emission levels for periodically monitored HF emissions to air from reference lines incinerating predominantly ONHW	665
Figure 8.109: Emission levels for periodically monitored NH ₃ emissions to air from reference lines incinerating predominantly MSW (1/2)	666
Figure 8.110: Emission levels for periodically monitored NH ₃ emissions to air from reference lines incinerating predominantly MSW (2/2)	667
Figure 8.111: Emission levels for periodically monitored NH ₃ emissions to air from reference lines incinerating predominantly ONHW	668
Figure 8.112: Emission levels for periodically monitored PCDD/F emissions to air from reference lines incinerating predominantly MSW (1/3)	669
Figure 8.113: Emission levels for periodically monitored PCDD/F emissions to air from reference lines incinerating predominantly MSW (2/3)	670
Figure 8.114: Emission levels for periodically monitored PCDD/F emissions to air from reference lines incinerating predominantly MSW (3/3)	671
Figure 8.115: Emission levels for periodically monitored PCDD/F emissions to air from reference lines incinerating predominantly ONHW	672
Figure 8.116: Emission levels for periodically monitored dioxin-like PCB emissions to air from reference lines incinerating predominantly MSW	673
Figure 8.117: Emission levels for periodically monitored dioxin-like PCB emissions to air from reference lines incinerating predominantly ONHW	674
Figure 8.118: Comparative emission levels for emissions to air of PCDD/F and of dioxin-like PCBs measured in the same sample	675
Figure 8.119: Emission levels for periodically monitored PAH emissions to air from reference lines incinerating predominantly MSW	676
Figure 8.120: Emission levels for periodically monitored PAH emissions to air from reference lines incinerating predominantly ONHW	677
Figure 8.121: Emission levels for periodically monitored BaP emissions to air from reference lines incinerating predominantly MSW	678
Figure 8.122: Emission levels for periodically monitored BaP emissions to air from reference lines incinerating predominantly ONHW	679
Figure 8.123: Emission levels for periodically monitored Hg emissions to air from reference lines incinerating predominantly MSW (1/3)	680
Figure 8.124: Emission levels for periodically monitored Hg emissions to air from reference lines incinerating predominantly MSW (2/3)	681
Figure 8.125: Emission levels for periodically monitored Hg emissions to air from reference lines incinerating predominantly MSW (3/3)	682
Figure 8.126: Emission levels for periodically monitored Hg emissions to air from reference lines incinerating predominantly ONHW	683
Figure 8.127: Emission levels for periodically monitored Sb+As+Cr+Co+Cu+Pb+Mn+Ni+V emissions to air from reference lines incinerating predominantly MSW (1/3)	684
Figure 8.128: Emission levels for periodically monitored Sb+As+Cr+Co+Cu+Pb+Mn+Ni+V emissions to air from reference lines incinerating predominantly MSW (2/3)	685

Figure 8.129: Emission levels for periodically monitored Sb+As+Cr+Co+Cu+Pb+Mn+Ni+V emissions to air from reference lines incinerating predominantly MSW (3/3).....	686
Figure 8.130: Emission levels for periodically monitored Sb+As+Cr+Co+Cu+Pb+Mn+Ni+V emissions to air from reference lines incinerating predominantly ONHW	687
Figure 8.131: Emission levels for periodically monitored Cd+Tl emissions to air from reference lines incinerating predominantly MSW (1/3).....	688
Figure 8.132: Emission levels for periodically monitored Cd+Tl emissions to air from reference lines incinerating predominantly MSW (2/3).....	689
Figure 8.133: Emission levels for periodically monitored Cd+Tl emissions to air from reference lines incinerating predominantly MSW (3/3).....	690
Figure 8.134: Emission levels for periodically monitored Cd+Tl emissions to air from reference lines incinerating predominantly ONHW.....	691
Figure 8.135: Emission levels for periodically monitored HF emissions to air from reference lines incinerating predominantly SS.....	692
Figure 8.136: Emission levels for periodically monitored PCDD/F emissions to air from reference lines incinerating predominantly SS	693
Figure 8.137: Emission levels for periodically monitored Hg emissions to air from reference lines incinerating predominantly SS.....	694
Figure 8.138: Emission levels for periodically monitored Sb+As+Cr+Co+Cu+Pb+Mn+Ni+V emissions to air from reference lines incinerating predominantly SS.....	695
Figure 8.139: Emission levels for periodically monitored Cd+Tl emissions to air from reference lines incinerating predominantly SS.....	696
Figure 8.140: Emission levels for periodically monitored HF emissions to air from reference lines incinerating predominantly HW	697
Figure 8.141: Emission levels for periodically monitored NH ₃ emissions to air from reference lines incinerating predominantly HW	698
Figure 8.142: Emission levels for periodically monitored PCDD/F emissions to air from reference lines incinerating predominantly HW	699
Figure 8.143: Emission levels for periodically monitored dioxin-like PCB emissions to air from reference lines incinerating predominantly HW	700
Figure 8.144: Emission levels for periodically monitored PAH emissions to air from reference lines incinerating predominantly HW	701
Figure 8.145: Emission levels for periodically monitored BaP emissions to air from reference lines incinerating predominantly HW	702
Figure 8.146: Emission levels for periodically monitored Hg emissions to air from reference lines incinerating predominantly HW	703
Figure 8.147: Emission levels for periodically monitored Sb+As+Cr+Co+Cu+Pb+Mn+Ni+V emissions to air from reference lines incinerating predominantly HW.....	704
Figure 8.148: Emission levels for periodically monitored Cd+Tl emissions to air from reference lines incinerating predominantly HW	705
Figure 8.149: Distribution of PCDD/F measurements within different concentration ranges, achieved by the plants submitted by Belgium, FNADE/SVDU and HWE, based on short-term and long-term sampling	706
Figure 8.150: Percentage of measurements falling below different concentration thresholds, cumulatively for all the plants submitted by Belgium, FNADE/SVDU and HWE, for short-term and long-term measurements	707

List of tables

Table 1.1:	Purpose of various components of a waste incinerator	2
Table 1.2:	Amounts of municipal solid waste (MSW), hazardous waste (HW) and sewage sludge (SS) in EU Member States, and their treatment	4
Table 1.3:	Geographical distribution of incineration plants for municipal, hazardous and sewage sludge waste	5
Table 1.4:	Average MSW incineration plant capacity by country	7
Table 1.5:	Typical throughput ranges of thermal treatment technologies	7
Table 1.6:	Typical composition of waste in Germany	9
Table 1.7:	Gate fees in European MSW and HW incineration plants	16
Table 1.8:	Comparative costs of MSW incineration in different Member States	17
Table 1.9:	Specific investment costs for a new MSWI installation related to the annual capacity and some types of FGC in Germany	17
Table 1.10:	Example of the comparative individual cost elements for MSW and HW incineration plants	18
Table 2.1:	Typical reaction conditions and products from combustion, pyrolysis and gasification processes	22
Table 2.2:	Main impacts of waste selection and pre-treatment on residual waste	23
Table 2.3:	Summary of the differences between operators in the HWI market.....	26
Table 2.4:	Average composition of dewatered communal sewage sludge and industrial sewage sludge after dewatering	31
Table 2.5:	Summary of the current application of thermal treatment processes applied to different waste types	36
Table 2.6:	A comparison of the features of some different incineration chamber designs.....	46
Table 2.7:	Properties of various refuse-derived fuel (RDF) fractions treated in fluidised beds	52
Table 2.8:	Main operational criteria for stationary fluidised beds.....	55
Table 2.9:	Typical reaction conditions and products of combustion, pyrolysis and gasification processes	57
Table 2.10:	Ranges and typical net calorific values for some incinerator input wastes	79
Table 2.11:	Factors taken into account when selecting the design of the energy cycle for waste incineration plants	81
Table 2.12:	Example data showing the variation in heat and electricity output at three different plants in Sweden when using various different types of heat pumps	90
Table 2.13:	Steam-water cycle improvements: effect on efficiency and other aspects	91
Table 2.14:	Summary of the main FGC systems applied in the WI reference lines that participated in the 2016 data collection.....	93
Table 2.15:	Operational information for different bag filter materials	99
Table 2.16:	Comparison of features of various alkaline reagents.....	106
Table 2.17:	Advantages and disadvantages of urea and ammonia use for SNCR	112
Table 3.1:	Distribution of various substances in the outlet streams of an example MSWI installation (in mass %)	142
Table 3.2:	Percentage (%) distribution of metals in the outlet streams of a hazardous waste incineration process.....	142
Table 3.3:	Average operating conditions during partitioning tests on a HWI installation	143
Table 3.4:	PCDD/F balance for a municipal waste incineration plant in Germany.....	143
Table 3.5:	Example PCDD/F load data for an MSWI in France	144
Table 3.6:	Flue-gas concentrations after the boiler (raw flue-gas) at various waste incineration plants (O ₂ reference value 11 %).....	144
Table 3.7:	Continuously monitored emissions from reference lines incinerating predominantly clinical waste.....	219
Table 3.8:	Periodically monitored emissions from reference lines incinerating predominantly clinical waste (1/2)	219
Table 3.9:	Periodically monitored emissions from reference lines incinerating predominantly clinical waste (2/2)	220
Table 3.10:	Typical values of the amount of scrubbing water arising from FGC at waste incineration plants treating wastes with a low chlorine content	221
Table 3.11:	Other possible waste water sources, and their approximate quantities, from waste incineration plants	223
Table 3.12:	Typical contamination of waste water from wet FGC of waste incineration plants before treatment.....	224
Table 3.13:	Typical data on the quantities of residues arising from waste incineration plants	244

Table 3.14:	Concentration of organic compounds in the solid residues from the flue-gas cleaning system	245
Table 3.15:	Concentration of organic compounds in the bottom ash/slag	246
Table 3.16:	Concentration of organic compounds in the solid residues from the waste water treatment plant	247
Table 3.17:	Main components of raw bottom ash	247
Table 3.18:	Chemical composition of bottom ash from the incineration of MSW	248
Table 3.19:	Leaching properties of untreated bottom ash	248
Table 3.20:	Methods and parameters used by waste incineration plants to ensure the efficient destruction of hazardous waste compounds	249
Table 3.21:	Typical leaching values of bottom ash from the incineration in hazardous waste incineration plants	252
Table 3.22:	Content of phosphorus, PAHs, PCBs and PCDD/F in the solid residues coming from the incineration of sewage sludge	253
Table 3.23:	Leaching values of bottom ash from fluidised bed furnaces	255
Table 3.24:	Incineration bottom ash treatment plants' characteristics	256
Table 3.25:	Plants treating slag/bottom ash with European waste code 19 01 12: quantities treated in 2014 and percentages of ferrous and non-ferrous metals recovered	257
Table 3.26:	Plants treating slag/bottom ash with European waste code 19 01 11* in 2014: quantities treated and percentages of ferrous and non-ferrous metals recovered	258
Table 3.27:	Input and output of European incineration bottom ash treatment plants in 2014	258
Table 3.28:	Leaching values of bottom ash after treatment	260
Table 3.29:	Dust emissions to air from incineration bottom ash treatment – Periodic measurements..	260
Table 3.30:	Reported emissions to water from the treatment of incineration slags and bottom ashes with the techniques used and points of release	262
Table 3.31:	Energy and water use reported in 2014 by incineration bottom ash treatment plants	264
Table 3.32:	Factors influencing energy recovery options	269
Table 3.33:	Steam parameters of plants incinerating predominantly hazardous waste	274
Table 3.34:	Steam parameters of plants incinerating predominantly sewage sludge	274
Table 3.35:	Gross electrical efficiency of plants incinerating predominantly hazardous waste	275
Table 3.36:	Gross electrical efficiency of plants incinerating predominantly sewage sludge	275
Table 3.37:	Electricity and heat demand data per tonne of waste treated	277
Table 3.38:	Sources of noise at waste incineration plants	284
Table 3.39:	Stoichiometric calculation of amounts of various reagents used for absorption during flue-gas cleaning (reactants expressed at 100 % concentration and purity)	286
Table 3.40:	Amount of additives used by merchant hazardous waste incineration processes	287
Table 4.1:	Information for each technique in this chapter	289
Table 4.2:	Techniques applied for the checking and sampling of various waste types	301
Table 4.3:	Some examples of applied storage techniques for various waste types	304
Table 4.4:	Main techniques for reducing fugitive diffuse emissions to air, odour releases and GHG emissions	307
Table 4.5:	Some segregation techniques applied for various waste types	309
Table 4.6:	Comparison of combustion and thermal treatment technologies and factors affecting their applicability and operational suitability	316
Table 4.7:	Raw flue-gas measurements at a test plant under normal operation, with IR camera and O ₂ conditioning	325
Table 4.8:	Residue quality using enriched combustion air (O ₂ at 25–27 %)	333
Table 4.9:	Relationship between the additional energy efficiency and the cooling medium (district heating) return temperature	365
Table 4.10:	Comparison of the achievable electrical energy efficiency with the external superheater at the Laanila plant	369
Table 4.11:	Operational data associated with the use of pre-dedusting systems	376
Table 4.12:	A comparison of dust removal systems	377
Table 4.13:	Energy requirements associated with the use of various pre-dedusters	377
Table 4.14:	Emission levels associated with the use of BF flue-gas polishing systems	379
Table 4.15:	Operational data associated with the use of flue-gas polishing	380
Table 4.16:	Cross-media effects associated with the use of additional flue-gas polishing	380
Table 4.17:	Emission levels associated with the use of wet scrubbers	382
Table 4.18:	Operational data associated with the use of wet FGC	382
Table 4.19:	Cross-media effects associated with the use of wet scrubber FGC	383
Table 4.20:	Estimated investment costs of selected components of wet FGC systems	384
Table 4.21:	Emission levels associated with the use of semi-wet scrubbers	386
Table 4.22:	Operational data associated with the use of semi-wet FGC	386

Table 4.23:	Cross-media effects associated with the use of semi-wet acid gas treatment.....	387
Table 4.24:	Estimated investment costs of selected components of typical semi-wet FGC systems	388
Table 4.25:	Emission levels associated with the use of hydrated lime in dry FGC processes.....	389
Table 4.26:	Emission levels associated with the use of sodium bicarbonate in dry FGC processes	389
Table 4.27:	Operational data associated with the use of dry FGC	390
Table 4.28:	Cross-media effects associated with the use of dry FGC	390
Table 4.29:	Operational data associated with the use of residue recirculation	393
Table 4.30:	Emission levels associated with the use of intermediate systems	394
Table 4.31:	Emission levels associated with the use of SNCR	401
Table 4.32:	Operational data associated with the use of SNCR	402
Table 4.33:	Consumption levels associated with the use of SNCR.....	403
Table 4.34:	Emission levels associated with the use of SCR	405
Table 4.35:	Operational data associated with the use of SCR	405
Table 4.36:	Cross-media effects associated with the use of SCR.....	408
Table 4.37:	Emission levels associated with the use of SCR by catalytic filter bags	410
Table 4.38:	Destruction efficiency data for catalytic filter bags over 21 months of operation.....	415
Table 4.39:	Operational data associated with the use of the fixed-bed adsorption static coke filters....	418
Table 4.40:	Cross-media effects associated with the use of the fixed-bed adsorption static filters.....	418
Table 4.41:	Operational aspects data associated with the use of carbon-impregnated materials in wet scrubbers	420
Table 4.42:	Assessment of the applicability of condensing scrubbers for mercury removal	427
Table 4.43:	Mercury emissions to water from plants using ion exchange.....	446
Table 4.44:	Quantity of HCl (30 %) recovered per tonne of waste	448
Table 4.45:	Quantity of gypsum recovered per tonne of waste treated	450
Table 4.46:	Results of a testing period carried out to remove Mo and Sb at the Esbjerg incineration plant in Denmark.....	452
Table 4.47:	Bottom ash output concentration data reported for an example bottom ash treatment facility	461
Table 4.48:	Bottom ash output eluate data reported for an example bottom ash treatment.....	461
Table 4.49:	Relative yield of various output fractions of wet bottom ash treatment	463
Table 4.50:	Example of leaching results of the produced granulates	464
Table 4.51:	Bottom ash output concentration (mg/kg) data reported for an example bottom ash treatment facility	464
Table 4.52:	Bottom ash eluate (µg/l) data reported for an example bottom ash treatment facility	465
Table 5.1:	BAT-associated environmental performance levels for unburnt substances in slags and bottom ashes from the incineration of waste.....	487
Table 5.2:	BAT-associated energy efficiency levels (BAT-AEELs) for the incineration of waste.....	490
Table 5.3:	BAT-associated emission levels (BAT-AELs) for channelled emissions to air of dust, metals and metalloids from the incineration of waste	493
Table 5.4:	BAT-associated emission levels (BAT-AELs) for channelled dust emissions to air from the enclosed treatment of slags and bottom ashes with extraction of air.....	494
Table 5.5:	BAT-associated emission levels (BAT-AELs) for channelled emissions to air of HCl, HF and SO ₂ from the incineration of waste.....	495
Table 5.6:	BAT-associated emission levels (BAT-AELs) for channelled NO _x and CO emissions to air from the incineration of waste and for channelled NH ₃ emissions to air from the use of SNCR and/or SCR	496
Table 5.7:	BAT-associated emission levels (BAT-AELs) for channelled emissions to air of TVOC, PCDD/F and dioxin-like PCBs from the incineration of waste.....	497
Table 5.8:	BAT-associated emission levels (BAT-AELs) for channelled mercury emissions to air from the incineration of waste.....	499
Table 5.9:	BAT-AELs for direct emissions to a receiving water body	501
Table 5.10:	BAT-AELs for indirect emissions to a receiving water body	501
Table 6.1:	Emissions to air of the flameless pressurised oxycombustion process using three different waste types.....	514
Table 6.2:	Leaching test of the slag produced by the flameless pressurised oxycombustion process using three different waste types	514
Table 7.1:	Key milestones of the WI BREF review process	519
Table 7.2:	Split views expressed	520
Table 8.1:	Summary information from the performance test of an electricity-only plant	524
Table 8.2:	Summary information from the performance test of an electricity-oriented CHP plant	525
Table 8.3:	Summary information from the performance test of a heat-only plant	527
Table 8.4:	Summary information from the performance test of a heat-oriented CHP plant.....	528
Table 8.5:	Summary information from the performance test of a plant with a hybrid configuration	530

Table 8.6:	Summary calculation of the gross energy efficiency of the part of the plant described as a virtual heat-oriented CHP plant	530
Table 8.7:	Summary calculation of the gross electrical efficiency of the part of the plant described as a virtual electricity-only plant	531
Table 8.8:	Example of a multi-criteria assessment of FGC system selection	532
Table 8.9:	Example of a multi-criteria cost assessment used for comparing FGC system options	533

SCOPE

This BREF for waste incineration covers the following activities specified in Annex I to Directive 2010/75/EU:

- 5.2 Disposal or recovery of waste in waste incineration plants:
 - (a) for non-hazardous waste with a capacity exceeding 3 tonnes per hour;
 - (b) for hazardous waste with a capacity exceeding 10 tonnes per day.

- 5.2 Disposal or recovery of waste in waste co-incineration plants:
 - (a) for non-hazardous waste with a capacity exceeding 3 tonnes per hour;
 - (b) for hazardous waste with a capacity exceeding 10 tonnes per day;
 whose main purpose is not the production of material products and where at least one of the following conditions is fulfilled:
 - only waste, other than waste defined in Article 3(31)(b) of Directive 2010/75/EU is combusted;
 - more than 40 % of the resulting heat release comes from hazardous waste;
 - mixed municipal waste is combusted.

- 5.3 (a) Disposal of non-hazardous waste with a capacity exceeding 50 tonnes per day involving the treatment of slags and/or bottom ashes from the incineration of waste.

- 5.3 (b) Recovery, or a mix of recovery and disposal, of non-hazardous waste with a capacity exceeding 75 tonnes per day involving the treatment of slags and/or bottom ashes from the incineration of waste.

- 5.1 Disposal or recovery of hazardous waste with a capacity exceeding 10 tonnes per day involving the treatment of slags and/or bottom ashes from the incineration of waste.

This BREF does not address the following:

- Pre-treatment of waste prior to incineration. This may be covered by the BREF for Waste Treatment (WT).
- Treatment of incineration fly ashes and other residues resulting from flue-gas cleaning (FGC). This may be covered by the BREF for Waste Treatment (WT).
- Incineration or co-incineration of exclusively gaseous waste other than that resulting from the thermal treatment of waste.
- Treatment of waste in plants covered by Article 42(2) of Directive 2010/75/EU.

Other reference documents which could be relevant for the activities covered by this BREF are the following:

- Waste Treatment (WT);
- Economics and Cross-Media Effects (ECM);
- Emissions from Storage (EFS);
- Energy Efficiency (ENE);
- Industrial Cooling Systems (ICS);
- Monitoring of Emissions to Air and Water from IED Installations (ROM);
- Large Combustion Plants (LCP);
- Common Waste Water and Waste Gas Treatment/Management Systems in the Chemical Sector (CWW).

Scope

The scope of this BREF does not include matters that only concern safety in the workplace or the safety of products because these matters are not covered by the Directive. They are discussed only where they affect matters within the scope of the Directive.

1 GENERAL INFORMATION ON WASTE INCINERATION

1.1 Purpose of incineration and basic concepts

[1, UBA 2001], [64, TWG 2003]

Incineration is used as a treatment for a very wide range of wastes. Incineration itself is commonly only one part of a complex waste treatment system that, altogether, provides for the overall management of the broad range of wastes that arise in society.

The incineration sector has undergone rapid technological development over the last 25 years. Much of this change has been driven by legislation specific to the industry and this has, in particular, reduced emissions to air and water. Continual process development is ongoing, with the sector now developing techniques which limit costs, whilst maintaining or improving environmental performance.

The first objective of waste incineration is to treat wastes so as to reduce their volume and hazard, whilst capturing (and thus concentrating) or destroying potentially harmful substances that are, or may be, released during incineration. Incineration processes can also provide a means to enable recovery of the energy, mineral and/or chemical content of waste. Energy recovery from municipal and similar waste has become an important second objective of waste incineration ('waste-to-energy', or 'energy-from-waste', concept).

Basically, waste incineration is the oxidation of the combustible materials contained in the waste. Waste is generally a highly heterogeneous material, consisting essentially of organic substances, minerals, metals and water. During incineration, flue-gases are created that will contain the majority of the available fuel energy as heat.

The organic fuel substances in the waste will burn when they have reached the necessary ignition temperature and come into contact with oxygen. The actual combustion process takes place in the gas phase in fractions of seconds and simultaneously releases energy where the calorific value of the waste and oxygen supply is sufficient; this can lead to a thermal chain reaction and self-supporting combustion, i.e. there is no need for the addition of other fuels.

The main stages of the incineration process are:

1. Drying and degassing - here, volatile content is evolved (e.g. hydrocarbons and water) at temperatures generally between 100 °C and 300 °C. The drying and degassing processes do not require any oxidising agent and are only dependent on the supplied heat.

2. Pyrolysis and gasification - pyrolysis is the further decomposition of organic substances in the absence of an oxidising agent at approximately 250–700 °C. Gasification of the carbonaceous residues is the reaction of the residues with water vapour and CO₂ at temperatures typically between 500 °C and 1 000 °C, but it can occur at temperatures up to 1 600 °C. Thus, solid organic matter is transferred to the gaseous phase. In addition to the temperature, water, steam and oxygen support this reaction.

3. Oxidation - the combustible gases created in the previous stages are oxidised, depending on the selected incineration method, at flue-gas temperatures generally between 800 °C and 1 450 °C.

These individual stages generally overlap, meaning that spatial and temporal separation of these stages during waste incineration may only be possible to a limited extent. Indeed, the processes partly occur in parallel and influence each other. Nevertheless, it is possible, using in-furnace technical measures, to influence these processes so as to reduce polluting emissions. Such measures include furnace design, air distribution and control engineering.

In fully oxidative incineration, the main constituents of the flue-gas are: water vapour, nitrogen, carbon dioxide and oxygen. Depending on the composition of the material incinerated and on the operating conditions, smaller amounts of CO, HCl, HF, HBr, HI, NO_x, NH₃, SO₂, VOCs, PCDD/F, PCBs and heavy metal compounds (among others) are formed or remain. Depending on the combustion temperatures during the main stages of incineration, volatile heavy metals and inorganic compounds (e.g. salts) are totally or partly evaporated. These substances are transferred from the input waste to both the flue-gas and the fly ash it contains. A mineral residue fly ash (dust) and heavier solid ash (bottom ash) are created. In municipal waste incinerators, bottom ash is approximately 10 vol-% and approximately 20–30 wt-% of the solid waste input. Fly ash quantities are much lower, generally only a few per cent of input. The proportions of solid residue vary greatly according to the waste type and detailed process design.

For effective oxidative combustion, a sufficient oxygen supply is essential. The air ratio number 'n' of the supplied incineration air to the chemically required (or stoichiometric) incineration air usually ranges from 1.2 to 2.5, depending on whether the fuel is gas, liquid or solid, and the furnace system.

Combustion is only one stage of the overall incineration process. Incinerators usually comprise a complex set of interacting technical components which, when considered together, effect an overall treatment of the waste. Each of these components has a slightly different main purpose, as described in Table 1.1 below.

Table 1.1: Purpose of various components of a waste incinerator

Objective	Responsibility of
<ul style="list-style-type: none">• Destruction of organic substances• Evaporation of water• Evaporation of volatile heavy metals and inorganic salts• Production of potentially exploitable slag• Volume reduction of residues	Furnace
<ul style="list-style-type: none">• Recovery of useable energy	Energy recovery system
<ul style="list-style-type: none">• Removal and concentration of volatile heavy metals and inorganic matter into solid residues, e.g. flue-gas cleaning residues, sludge from waste water treatment• Minimising emissions to all media	Flue-gas cleaning

Source: [1, UBA 2001], [64, TWG 2003]

1.2 Overview of waste incineration in Europe

The scale of use of incineration as a waste management method varies greatly from location to location. For example, in European Member States the incineration share in municipal waste treatments ranges from zero to 55 %.

Table 1.2 below gives an estimate of the treatment of the waste arising in each MS for municipal solid waste, hazardous waste and sewage sludge. Deposited waste is included because a considerable proportion of these wastes may, in future, be diverted to other waste treatment methods, including incineration.

Note: as definitions and waste categories differ from one country to another, some of the values given may not be directly comparable.

Table 1.2: Amounts of municipal solid waste (MSW), hazardous waste (HW) and sewage sludge (SS) in EU Member States, and their treatment

Country	Municipal solid waste (MSW)				Hazardous waste (HW)				Sewage sludge (SS)			
	Total MSW generation (in 10 ⁶ tonnes)	Year of data source	% landfilled (or/and amount in 10 ⁶ tonnes)	% incinerated (or/and amount in 10 ⁶ tonnes)	Total HW generation (in 10 ⁶ tonnes)	Year of data source	Amount landfilled (in 10 ⁶ tonnes)	Amount incinerated (in 10 ⁶ tonnes)	Total SS generation (in 10 ⁶ tonnes as dry solids)	Year of data source	Amount landfilled (in 10 ⁶ tonnes)	Amount incinerated (in 10 ⁶ tonnes)
Belgium ⁽¹⁾	4.65	2015	0.04	2.05	3.81	2016	1.22	0.42	0.16	2012	0	0.089
Bulgaria ⁽¹⁾	3.01	2015	1.99	0.08	13.3	2016	13.1	0.006	0.06	2015	0.0085	0
Czechia ⁽¹⁾	3.34	2015	1.75(est.)	0.59(est.)	1.09	2016	0.033	0.107	0.21	2015	0.021	0.008
Denmark	11 ⁽²⁾ 4.48 ⁽¹⁾	2015	4% 0.05	27% 2.36	0.55	2016	0.17	0.12	0.13	2016	0.001	0.035
Germany	51.1	2014	0	32%	25.3	2014	4.6 ⁽¹⁾	4.5	1.8	2014	0	1 ⁽¹⁾
Estonia ⁽¹⁾	0.47	2015	0.035	0.24	9.68	2016	9.23	0.013	0.02	2013	0.002	NI
Ireland	2.62	2014	0.54	0.89	0.48 ⁽¹⁾	2014	0.04 ⁽¹⁾	0.045 ⁽¹⁾	0.06 ⁽¹⁾	2015	0.0001 ⁽¹⁾	0 ⁽¹⁾
Greece ⁽¹⁾	5.27	2015	4.43	0.018	0.22	2014	0.02	0.006	0.12	2014	0.039	0.039
Spain	21.2	2015	57.3%	12.7%	3.18	2016	0.6	0.22	1.13	2012	0.08	0.075
France	34.1	2016	22.4%	35.9%	11	2016	2.3	2.6	1.2	2016	NI	NI
Croatia ⁽¹⁾	1.65	2015	1.32	0	0.174	2016	0.006	0.0014	0.018	2015	0.016	NI
Italy	29.52	2015	26.5%	18.9%	9.1	2015	1.3	0.39	3.1	2015	0.4	0.01
Cyprus ⁽¹⁾	0.54 (estimated.)	2015	0.43	0	0.159	2016	0.129	0.0002	0.007	2015	0	0
Latvia ⁽¹⁾	0.80	2015	0.49	0	0.066	2016	0.002	0.003	0.008	2012	0.0002	0
Lithuania ⁽¹⁾	1.30	2015	0.70	0.15	0.176	2016	0.01	0.005	0.043	2015	0	0
Luxembourg ⁽¹⁾	0.35	2015	0.06	0.12	0.427	2016	0.007	0.042	0.009	2015	NI	0.001
Hungary ⁽¹⁾	3.71	2015	1.99	0.52	0.174	2016	0.069	0.1	0.157	2015	0.005	0.024
Malta ⁽¹⁾	0.27	2015	0.24	0.001	0.174	2016	0	0.0005	0.008	2015	0.008	0
Netherlands	8.86 ⁽¹⁾	2015	0.13 ⁽¹⁾	4.15 ⁽¹⁾	5.13 ⁽¹⁾	2016	1 ⁽¹⁾	0.716 ⁽¹⁾	0.53	2015	0	0.321 ⁽¹⁾
Austria ⁽¹⁾	4.84	2015	0.14	1.83	1.26	2016	0.066	NI	0.239	2014	0.003	0.139
Poland ⁽¹⁾	10.8 (estimated.)	2015	5.90 (est.)	1.44 (est.)	1.91	2016	0.30	0.161	0.568	2015	0.04	0.057
Portugal	4.71	2014	2.31	0.97	0.83 ⁽¹⁾	2016	0.24 ⁽¹⁾	0.046 ⁽¹⁾	0.339 ⁽¹⁾	2012	0.011	0
Romania ⁽¹⁾	4.9	2015	3.56	0.13	0.619	2016	0.12	0.147	0.210	2015	0.104	0
Slovenia ⁽¹⁾	0.93	2015	0.21	0.16 (est.)	0.124	2016	0.01	0.015	0.029	2015	0.0002	0.013
Slovakia ⁽¹⁾	1.78	2015	1.23	0.19	0.496	2016	0.08	0.019	0.056	2015	0.005	0.003
Finland	2.7	2016	3%	55%	2.0	2016	86%	8%	0.8 (wet weight)	2016	2%	0
Sweden	4.55	2017	0.4% (0.02)	53% (2.4)	2.0	2016	0.63	0.32	0.2	2014	0.003	0.002
United Kingdom ⁽¹⁾	31.46	2015	7.12	9.90	6.11	2016	0.84	0.33	1.14	2012	0.005	0.229
EU-28 totals ⁽¹⁾	244.82	2015	26%	27%	94.73	2014	37.3	10.2	9.1	2012	0.67	2.3

NB: ; NI: no information provided; NA: not applicable. As definitions and waste categories differ from one Member State to another, some of the values given may not be directly comparable; the balance to 100 % for the treatment methods is due to other methods besides landfilling and incineration, e.g. recovery and recycling.
⁽¹⁾ Eurostat data (env_wasmun, env_wastrt, env_ww_spd accessed on 20/11/2018). In all other cases the data has been supplied by the Member State directly.
⁽²⁾ includes all non-hazardous waste generated, excluding sewage sludge and contaminated soil
Source: [7. TWG 2017], [14. Eurostat 2018]

Table 1.3 shows the number and total capacity of existing incineration plants (not including planned sites) for various waste types.

Table 1.3: Geographical distribution of incineration plants for municipal, hazardous and sewage sludge waste

Country (base year)	Total number of MSW incinerators	Capacity (Mt/yr)	Total number of HW incinerators	Capacity (Mt/yr)	Total number of dedicated sewage sludge incinerators	Capacity (Mt/yr) (dry solids)
Austria	12	2.5	2	0.1	1	NI
Belgium	16	2.7	3	0.3	1	0.02
Czechia	3	0.65	NI	NI	NI	NI
Denmark	29 ⁽¹⁾	4.8 ⁽¹⁾	3	0.26	3	0.1
Estonia	NI	0.25	NI	NI	NI	NI
Finland	9	1.7	1	0.2	3	0.039
France	127	14.4	48 ⁽²⁾	2.03 ⁽³⁾	27	NI
Germany	89	22.8	31 ⁽⁴⁾	1.5	19	2.2
Hungary	1	0.38	NI	NI	NI	NI
Ireland	1	0.22	11	NI	NI	NI
Italy	44	7.3	NI	NI	NI	NI
Lithuania	NI	0.23	NI	NI	NI	NI
Luxembourg	1	0.15	0	0	NI	NI
Netherlands	13	7.6	1	0.1	2	0.19
Norway	15	1.6	NI	NI	NI	NI
Poland	NI	0.04	NI	NI	NI	NI
Portugal	3	1.2	5	NI	NI	NI
Slovakia	2	0.17	NI	NI	NI	NI
Slovenia	NI	0.004	NI	NI	NI	NI
Spain	10	2.64	1	0.038	2	0.032
Sweden ⁽⁵⁾	34	6.6	1	0.1 ⁽⁶⁾	0	0
Switzerland	29	3.29	11	2	14	0.1
United Kingdom	NI	6.18	3	0.12	11	0.42
EU 28	470	NI	NI	NI	NI	NI

NI: No information provided.

⁽¹⁾ Includes all incineration and co-incineration plants mainly treating non-hazardous solid waste. The [16, Wilts et al. 2017] estimate for MSW alone is 3.3 Mt/yr.

⁽²⁾ Includes 28 dedicated commercial sites and 20 in-house plants (2015 data).

⁽³⁾ 1.51 for commercial sites and 0.52 for in-house plants (2015 data).

⁽⁴⁾ Figure includes installations used in the chemical industry.

⁽⁵⁾ A total of 54 WI lines (boilers) are in operation at the 34 installations. 14 of the 34 installations are permitted for the incineration of HW too.

⁽⁶⁾ Additionally, the incineration of 0.56 Mt/yr is permitted at the 14 MSWIs referred to in footnote ⁽⁵⁾.

Sources: [1, UBA 2001], [64, TWG 2003], [47, TWG 2018], [16, Wilts et al. 2017], [34, ISWA 2012]

Figure 1.1 shows the variation across Member States in per capita capacity for municipal waste incineration. Member States where no incineration plants were in operation in 2014 are not displayed.

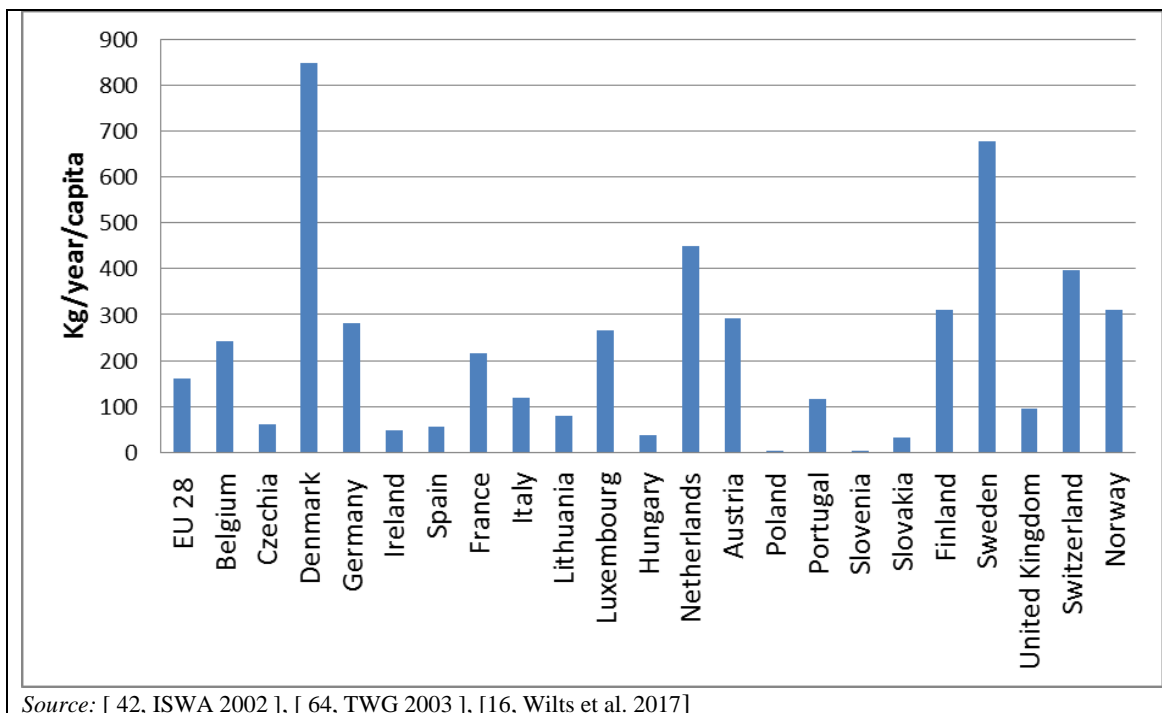

Figure 1.1: Municipal waste incineration capacity per capita in 2014

1.3 Plant sizes

The size of installations varies greatly across Europe. Variations in size can be seen within and between technology and waste types. The largest MSW plant in Europe has a capacity in excess of 1 million tonnes of waste per year.

Table 1.4 below shows the variation in average MSW incinerator capacity by country.

Table 1.4: Average MSW incineration plant capacity by country

Country	Average MSW incinerator capacity (kilotonnes/yr)
Austria	178
Belgium	141
Denmark	114
Finland	180
France	113
Germany	256
Italy	161
Netherlands	488
Portugal	390
Spain	264
Sweden	136
United Kingdom	246
Norway	60
Switzerland	110
AVERAGE	193
<i>Source: [11, Assure 2001], [64, TWG 2003], [47, TWG 2018].</i>	

Table 1.5 below shows the typical application range of the main different incineration technologies.

Table 1.5: Typical throughput ranges of thermal treatment technologies

Technology	Typical application range (tonnes/day)
Moving grate (mass burn)	120–720
Fluidised bed	36–200
Rotary kiln	10–350
Pyrolysis	10–100
Gasification	250–500
NB: Values are for <u>typical</u> applied ranges – each is also applied outside the range shown.	
<i>Source: [10, Juniper 1997], [64, TWG 2003]</i>	

1.4 Waste composition and process design

The precise design of a waste incineration plant will depend on the type of waste that is being treated. The following parameters and their variability are key drivers:

- waste chemical composition;
- waste physical composition, e.g. particle size;
- waste thermal characteristics, e.g. calorific value, moisture levels.

Processes designed for a narrow range of specific inputs can usually be optimised more than those that receive wastes with greater variability. This in turn can allow improvements to be made in process stability and environmental performance, and may allow the simplification of downstream operations such as flue-gas cleaning. As flue-gas cleaning is often a significant contributor to overall incineration costs (i.e. approximately 15 % to 35 % of the total capital investment) this can then lead to reduced treatment costs at the incinerator. The external costs (i.e. those generally beyond the IED installation boundary) of pre-treatment, or the selective collection of certain wastes, can however add significantly to the overall costs of waste management and to emissions from the entire waste management system. Often, decisions concerning the wider management of waste (i.e. the complete waste arising, collection, transportation, treatment, disposal, etc.) take into account a very large number of factors. The selection of the incineration process can form a part of this wider process.

The waste collection and pre-treatment systems utilised can have a great impact on the type and nature of waste that will finally be received at the incinerator (e.g. mixed municipal waste or RDF) and hence on the type of incinerator that is best suited to this waste. Provision for the separate collection of various fractions of household waste can have a large influence over the average composition of the waste received at the MSWI plant. For example, the separate collection of some batteries and dental amalgam can significantly reduce mercury inputs to the incineration plant. [64, TWG 2003]

The cost of the processes used for the management of residues arising at the incinerator and for the distribution and use of the energy recovered also play a role in the overall process selection.

In many cases, waste incinerators may have only limited control over the precise content of the wastes they receive. This results in the need for some installations to be designed so that they are sufficiently flexible to cope with the wide range of waste inputs they may receive. This applies to both the combustion stage and the subsequent flue-gas cleaning stages.

The main types of waste to which incineration is applied as a treatment are:

- municipal wastes (residual wastes - not pretreated);
- pretreated municipal wastes (e.g. selected fractions or RDF);
- non-hazardous industrial wastes and packaging;
- hazardous wastes;
- sewage sludges;
- clinical wastes.

Many incineration plants accept several of these types of waste. Waste itself is commonly classified in a number different ways:

- by origin, e.g. household, commercial, industrial;
- by its nature, e.g. putrescible, hazardous;
- by the method used for its management, e.g. separately collected, recovered material.

These different classes overlap. For example, wastes of various origins may contain putrescible or hazardous fractions. [64, TWG 2003]

Table 1.6 below provides data concerning the content of waste arising in Germany. Sewage sludge includes sludge from the waste water treatment of communities and industries.

Table 1.6: Typical composition of waste in Germany

Parameter	Municipal waste	Hazardous waste	Sewage sludge
Calorific value (upper) (MJ/kg)	7–15	1–42	2–14
Water (%)	15–40	0–100	3–97
Ash	20–35	0–100	1–60
Carbon (% DS)	18–40	5–99	30–35
Hydrogen (% DS)	1–5	1–20	2–5
Nitrogen (% DS)	0.2–1.5	0–15	1–4
Oxygen (% DS)	15–22	<i>NI</i>	10–25
Sulphur (% DS)	0.1–0.5	<i>NI</i>	0.2–1.5
Fluorine (% DS)	0.01–0.035	0–50	0.1–1
Chlorine (% DS)	0.1–1	0–80	0.05–4
Bromine (% DS)	<i>NI</i>	0–80	<i>NI</i>
Iodine (% DS)	<i>NI</i>	0–50	<i>NI</i>
Lead (mg/kg DS)	100–2 000	0–200 000	4–1 000
Cadmium (mg/kg DS)	1–15	0–10 000	0.1–50
Copper (mg/kg DS)	200–700	<i>NI</i>	10–1 800
Zinc (mg/kg DS)	400–1 400	<i>NI</i>	10–5 700
Mercury (mg/kg DS)	1–5	0–40 000	0.05–10
Thallium (mg/kg DS)	< 0.1	<i>NI</i>	0.1–5
Manganese (mg/kg DS)	250	<i>NI</i>	300–1 800
Vanadium (mg/kg DS)	4–11	<i>NI</i>	10–150
Nickel (mg/kg DS)	30–50	<i>NI</i>	3–500
Cobalt (mg/kg DS)	3–10	<i>NI</i>	8–35
Arsenic (mg/kg DS)	2–5	<i>NI</i>	1–35
Chrome (mg/kg DS)	40–200	<i>NI</i>	1–800
Selenium (mg/kg DS)	0.21–15	<i>NI</i>	0.1–8
PCB (mg/kg DS)	0.2–0.4	Up to 60 %	0.01–0.13
PCDD/F (ng I-TEQ/kg)	50–250	10–10 000	8.5–73
NB: <i>NI</i> : no information provided. % DS = percentage dry solids. The calorific value for sewage sludge relates to raw sludge of > 97 % DS. Subfractions of HW can show variations outside these ranges. Source: [1, UBA 2001], [64, TWG 2003]			

The range of installation designs is almost as wide as the range of waste compositions.

New plants have the advantage that a specific technological solution can be designed to meet the specific nature of the waste to be treated in the plant. They also benefit from years of industry development and knowledge of the practical application of techniques and may therefore be designed for high environmental standards, whilst containing costs.

Existing plants have significantly less flexibility when selecting upgrade options. Their design may be the product of 10 to 20 years of process evolution. Often in Europe this will have been motivated by requirements to reduce emissions to air and/or by the objective to increase energy efficiency. The next stage of process development will often then be highly (or even totally) dependent upon the existing design. Many site-specific local solutions can be seen in the sector. Many of these would probably be constructed in a different way if completely rebuilt. [6, EGTEI 2002].

1.5 Key environmental issues

Waste itself and its management are themselves a significant environmental issue. The thermal treatment of waste may therefore be seen as a response to the environmental threats posed by poorly managed or unmanaged waste streams.

The target of thermal treatment (see also Section 1.1) is to provide for an overall reduction in the environmental impact that might otherwise arise from the waste. However, in the course of the operation of incineration installations, emissions and consumption arise, whose existence or magnitude is influenced by the installation design and operation. This section therefore, briefly, summarises the main environmental issues that arise directly from incineration installations (i.e. it does not include the wider impacts or benefits of incineration). Essentially, these *direct impacts* fall into the following main categories:

- emissions to air and water ;
- residue production;
- process noise;
- energy consumption and production;
- raw material (reagent) consumption;
- fugitive emissions and odour – mainly from waste storage;
- reduction of the storage/handling/processing risks of hazardous wastes.

Other impacts beyond the scope of this document (but which can significantly impact upon the overall environmental impact of an entire project) arise from the following operations:

- transport of incoming waste and outgoing residues;
- extensive waste pre-treatment on site or off site (e.g. preparation of waste-derived fuels and the associated refuse treatment).

1.5.1 Emissions to air and water

Emissions to air have long been the focus of attention for waste incineration plants. Significant advances in technologies for the cleaning of flue-gases in particular have led to major reductions in the emissions to air.

However, the control of emissions to air remains an important issue for the sector. As the entire incineration process is usually under slightly subatmospheric pressure (because of the common inclusion of an induced draught extraction fan), emissions to air generally take place exclusively from the stack. [2, InfoMil 2002]

A summary of the main emissions to air from stack releases (these are described in more detail in Section 3.2.1) is shown below:

- dust, –particulate matter - various particle sizes;
- acid and other gases, –including HCl, HF, HBr, HI, SO₂, NO_x and NH₃;
- heavy metals, –including Hg, Cd, Tl, As, Ni and Pb;
- carbon dioxide, –not covered under the IED or this BREF;
- other carbon compounds, –including, CO, VOCs, PCDD/F and PCBs.

Releases to air from other sources may include:

- odour, –from handling and storage of untreated waste;
- greenhouse gases, –from decomposition of stored wastes, e.g. methane, CO₂;
- dust, –from dry reagent handling and waste storage areas.

The principle potential sources of releases to water (process-dependent) are:

- effluents from air pollution control devices, e.g. salts, metals;
- final effluent discharges from waste water treatment, e.g. salts, metals;
- boiler water - blowdown bleeds, e.g. salts;
- cooling water - from wet cooling systems, e.g. salts, biocides;
- road and other surface drainage, e.g. diluted waste leachates;
- incoming waste storage, handling and transfer areas, e.g. diluted wastes;
- raw material storage areas, e.g. treatment chemicals;
- residue handling, treatment and storage areas, e.g. salts, metals, organics.

The waste water produced at the installation can contain a wide range of potentially polluting substances depending upon its actual source. The actual release will be highly dependent on the treatment and control systems applied.

1.5.2 Production of residues and recoverable materials

The nature and quantity of residues / output materials produced are a key issue for the sector. This is because they both: (1) provide a measure of the completeness of the incineration process and (2) generally represent the largest potential waste arising at the installation.

Although the types and quantities of residue arising vary greatly according to the installation design, its operation and waste input, the following main waste streams are commonly produced during the incineration process: [64, TWG 2003], [1, UBA 2001]

- bottom ash and/or slag;
- boiler ash;
- fly ash;
- other residues from the flue-gas cleaning (e.g. calcium or sodium chlorides);
- sludge from waste water treatment.

In some cases these waste streams are segregated, while in other cases they are combined within or outside the process.

Substances which can be obtained after the treatment of the bottom ashes are:

- construction materials;
- ferrous metals;
- non-ferrous metals.

In addition, some plants using wet FGC processes with additional specific equipment recover:

- calcium sulphate (gypsum);
- hydrochloric acid;
- sodium carbonate;
- sodium chloride;
- zinc, lead, copper and cadmium.

Of these outputs, although very dependent upon the waste type, bottom ashes are generally produced in the largest quantities. In many locations, often depending on local legislation and practice, bottom ash is treated for recycling as an aggregate replacement. Rather high bottom ash re-use rates emerge from the following example data reported by some EU Member States [47, TWG 2018]:

- in France, 87 % recycling and 13% landfilling;
- in Italy, 83 % recycling and 17 % landfilling;
- In Finland, 100% recycling;
- In Sweden, 100 % re-use as landfill cover material;
- In Denmark, 100 % of the bottom ashes originating from the incineration of non-hazardous waste are recycled, while the bottom ashes from hazardous waste incineration are landfilled.

Residues produced from the flue-gas cleaning are an important source of waste production. The amount and nature of these varies, mainly according to the types of waste being incinerated and the technology that is employed.

1.5.3 Process noise

The noise aspect of waste incineration is comparable with other industries and with power generation plants. It is common practice for new municipal waste incineration plants to be installed in completely closed building(s), as far as possible. This normally includes operations such as the unloading of waste, mechanical pre-treatment, flue-gas treatment, and the treatment of residues. Usually, only some parts of flue-gas cleaning systems (pipes, tubes, SCR, heat exchangers, etc.), cooling facilities and the long-term storage of bottom ash are located directly in the open air. [2, InfoMil 2002]

The most important sources of external noise are:

- vehicles used for the transport of waste, chemicals and residues;
- mechanical pre-treatment of waste, e.g. shredding, baling;
- exhaust fans, extracting flue-gases from the incineration process and causing noise at the outlet of the stack;
- the cooling system (from evaporative cooling, especially in the case of air cooling condensers);
- turbo-generators (high level so usually placed in specific soundproofed buildings);
- boiler pressure emergency blowdowns (these require direct release to atmosphere for boiler safety reasons);
- compressors for compressed air;
- the transport and treatment of bottom ash (if on the same site).

SCR systems and flue-gas ducts give rise to little noise and are often not inside buildings. Other installation parts are not usually significant for external noise production but may contribute to general external noise production by the plant buildings.

1.5.4 Energy production and consumption

Waste incinerators both produce and consume energy. In the large majority of cases, the energetic value of the waste exceeds the process requirements, resulting in the net export of energy. This is often the case with municipal waste incinerators in particular.

Given the total quantities of waste arising, and its growth over many years, the incineration of waste can be seen to offer a large potential source of energy. In some MSs this energy source is already well exploited. This is particularly the case where CHP is used. Energy issues are discussed in more detail later in this document (see Sections 3.5 and 4.4). [64, TWG 2003]

Figure 1.2 below shows the production of heat and electricity from municipal waste incineration plants in some EU Member States. Overall, the total energy recovered in the EU 28 in waste-to-energy plants was estimated in 2013 at 275 000 TJ as recovered heat and 110 000 TJ as recovered electricity. Figure 1.2 highlights a general difference between northern EU countries, where WI plants are often designed to export electricity through district heating networks, and southern EU countries where the warmer climate makes heat demand highly seasonal, district heating networks are less common, and WI plants are often designed to export only electricity.

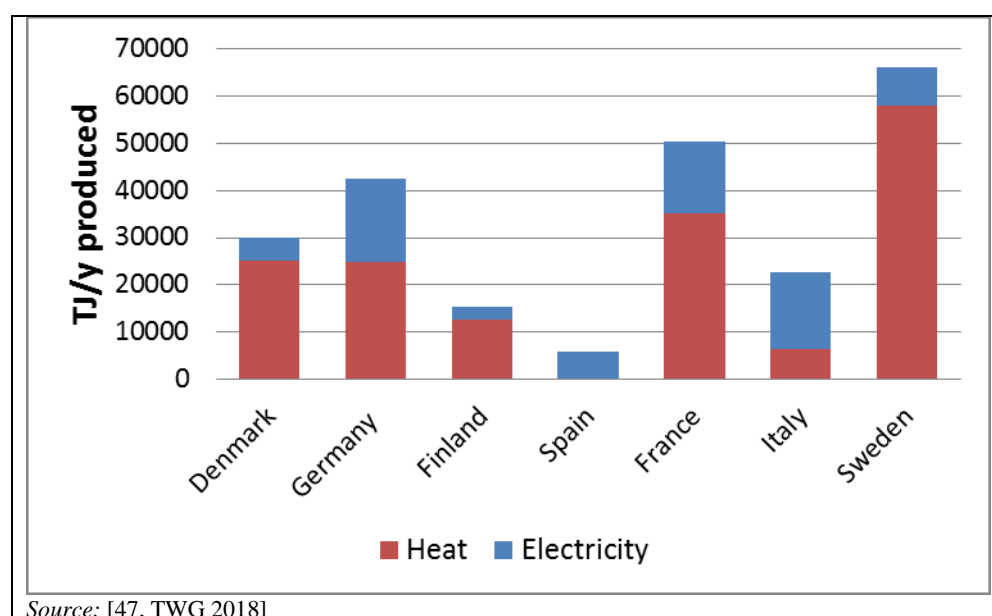

Figure 1.2: Energy production by municipal waste incinerators in Europe in 1999

Most municipal and commercial wastes, including refuse-derived fuels, contain a significant share of biogenic content (reaching 60 % and more in some cases). For sewage sludge incinerators treating sludges from biological waste water treatment and for dedicated wood waste incinerators, this share can typically be above 95 %. The energy derived from the biomass fraction may be considered to substitute for fossil fuel and therefore the recovery of energy from that fraction may be considered to contribute to a reduction in the overall carbon dioxide emissions from energy production. In some countries, this attracts subsidies and tax reductions. [64, TWG 2003]

Energy inputs to the incineration process can include:

- waste;
- support fuels, (e.g. diesel, natural gas):
 - for start-up and shutdown;
 - to maintain required temperatures with lower calorific value wastes;
 - for flue-gas reheating before treatment or release;
- imported electricity:
 - when the turbine(s) or all lines are stopped, and for plants without electricity generation.

(Note: some of the above energy inputs contribute to steam/heat production where boilers are used and therefore the energy is partially recovered in the process.)

Energy production, self-consumption and export can include:

- electricity;
- heat (as steam or hot water);
- syngas (for pyrolysis and gasification plants that do not burn the syngas on site).

The efficient recovery of the energy content of the waste is generally considered to be a key issue for the industry.

[74, TWG 2004]

1.5.5 Consumption of raw materials and energy

Waste incineration plants may consume the following:

- electricity, for process plant operation;
- heat, for specific process needs;
- fuels, support fuels (e.g. gas, light oils, coal, char);
- water, for flue-gas treatment, cooling and boiler operation;
- flue-gas cleaning reagents, e.g. caustic soda, limestone, quicklime, hydrated lime, sodium bicarbonate, sodium sulphite hydrogen peroxide, activated carbon, ammonia, and urea;
- water treatment reagents, e.g. acids, alkalis, trimercaptotriazine, sodium sulphite;
- high-pressure air.

[74, TWG 2004]

1.6 Economic information

The economic aspects of incineration vary greatly between regions and countries, not only due to technical aspects but also depending on waste management policies. [43, Eunomia 2001], [64, TWG 2003]

The costs of incineration are generally affected by the following factors:

- Costs of land acquisition.
- Scale (there may often be significant disadvantages for small-scale operation).
- Plant utilisation rate.
- The actual requirements for the treatment of flue-gases/effluents, e.g. the imposed emission limit values can drive the selection of particular technologies that in some circumstances impose significant additional capital and operating costs, including the costs of fuels, electricity, reagents and other consumables.
- The treatment and disposal/recovery of ash residues, e.g. bottom ash may often be used for construction purposes, in which case the landfilling cost is avoided. The costs of treatment for fly ash vary significantly, owing to the different approaches and regulations applied regarding the need for treatment prior to recovery or disposal, and the nature of the disposal site.
- The efficiency of energy recovery, and the revenue received for the energy delivered. The unit price of energy delivered and whether revenues are received for just heat or electricity or for both are both important determinants of net costs.
- The recovery of metals and the revenues received from this.
- Taxes or subsidies received for incineration and/or levied on emissions - direct and indirect subsidies can influence gate fees significantly i.e. in the range of 10–75 %.
- Architectural requirements.
- Development of the surrounding area for waste delivery access, and other infrastructure.
- Availability requirements, e.g. availability may be increased by installing redundant equipment, but this imposes additional capital costs.
- Planning and building cost/depreciation periods, taxes and subsidies, capital cost.
- Insurance costs.
- Administration, personnel, salary costs.

The owners and operators of incineration plants may be municipal bodies, as well as private companies. Public/private partnerships are also common. The financing cost of capital investments may vary depending upon the ownership.

Waste incineration plants receive fees for the treatment of the waste. They can also produce and sell electricity, steam, and heat, and recover other products, such as bottom ashes for use as civil construction material, iron scrap and non-ferrous scrap for use in the metal industry, HCl, salt or gypsum. The price paid for these commodities, and the investment required to produce them, has a significant impact on the operational cost of the installation. It can also be decisive when considering specific technical investments and process designs (e.g. whether heat can be sold at a price that justifies the investment required for its supply). The prices paid for these commodities vary from one MS to another or even from one location to another.

In addition, significant differences occur due to the variations in emission requirements, salary costs and depreciation periods, etc. For these reasons, the gate fees in Table 1.7 are only comparable to a limited extent:

Table 1.7: Gate fees in European MSW and HW incineration plants

Member States	Gate fees in EUR/t	
	Municipal waste	Hazardous waste
Belgium	57	100–1 500
Denmark	40–70	100–1 500
Finland	50–100	NI
France	50–120	50–1 500
Germany	100–350	50–1 500
Italy	70–120	100–1 000
Netherlands	90–180	50–5 000
Sweden	38–67 (average: 49)	50–2 500
United Kingdom	20–40	NI
NB: NI: no information provided Source: [1, UBA 2001], [47, TWG 2018],		

It is important not to confuse the real cost of the gate fee 'needed' in order to pay for the investment and operation and the market price that is adopted in order to deal with competition. Competition with alternative methods of waste management (e.g. landfills, fuel production) as well as investment costs and operating expenses have an effect on the final gate fee at incineration plants. Competition prices vary greatly from one Member State or location to another.

Table 1.8 shows (except where noted) the variation in municipal waste incineration costs across Member States. Note that the costs presented in Table 1.8 are different to those in Table 1.7 above (which presents data on *gate fees*).

Table 1.8: Comparative costs of MSW incineration in different Member States

	Pre-tax ⁽¹⁾ costs net of revenues in EUR per tonne waste input	Tax (for plant with energy recovery)	Revenues from energy supply (EUR per kWh)	Costs of ash treatment (EUR per tonne of ash unless otherwise specified)
AT	326 @ 60 kt/yr 159 @ 150 kt/yr 97 @ 300 kt/yr		Electricity: 0.036 Heat: 0.018	Bottom ash: 63 Flue-gas residues: 363
BE	72 average	EUR 12.7/t (Flanders)	Electricity: 0.025	Not available
DK	30 – 45	EUR 44/t	Electricity: 0.05	Bottom ash: 34 Flue-gas treatment residues: 80
FI	None		For gasification, Electricity: 0.034 Heat: 0.017	
FR	86–101 @ 37.5 kt/yr 80–90 @ 75 kt/yr 67–80 @ 150 kt/yr		Electricity: 0.033–0.046 Heat: 0.0076–0.023	Bottom ash: EUR 13–18 per tonne input waste
DE	250 (50 kt/yr and below) ⁽²⁾ 105 (200 kt/yr) ⁽²⁾ 65 @ 600 kt/yr ⁽²⁾		Electricity 0.015–0.025	Bottom ash: 25–30 Fly ash/air pollution control residues: 100–250
EL	None		Not known	Not known
IE	None		Not known	Not known
IT	41.3–93 (350 kt, depends on revenues for energy and packaging recovery)		Electricity: 0.14 (old) 0.04 (market) 0.05 (green cert.)	Bottom ash: 75 Fly ash and air pollution control residues: 29
LU	97 (120 kt)		Electricity: 0.025 (estimated)	Bottom ash: EUR 16 per tonne input waste Flue-gas residues: EUR 8 per tonne input waste
NL	71–110 ¹ 70–134 ¹		Electricity: 0.027–0.04 (estimated)	
PT	46–76 (est.)			No data
ES	34–56		Electricity: 0.036	
SE	21–53		Electricity: 0.03 Heat: 0.02	
UK	69 @ 100kt/yr 47 @ 200kt/yr		Electricity: 0.032	Bottom ash recycled (net cost to operator) fly ash: ~ 90

⁽¹⁾ Pre-tax cost refers to gross costs without any tax.
⁽²⁾ These figures are gate fees, not costs.
Source: [43, Eunomia 2001] [64, TWG 2003]

The following table illustrates how the capital costs of an entire new MSWI installation can vary with the flue-gas and residue treatment processes applied.

Table 1.9: Specific investment costs for a new MSWI installation related to the annual capacity and some types of FGC in Germany

Type of flue-gas cleaning	Specific investment costs (EUR/tonne waste input/yr)			
	100 ktonnes/yr	200 ktonnes/yr	300 ktonnes/yr	600 ktonnes/yr
Dry	670	532	442	347
Dry plus wet	745	596	501	394
Dry plus wet with residue processing	902	701	587	457

Source: [1, UBA 2001], [64, TWG 2003]

Table 1.10 shows some examples of average specific incineration costs (1999) for municipal waste and hazardous waste incineration plants (all new plants). The data indicate that the specific costs for incineration are heavily dependent on the financing costs of the capital and, therefore, on the investment costs and the plant capacity. Significant cost changes can occur and depend on the set-up, such as the depreciation period, interest costs, etc. Plant utilisation can also have a significant influence on the incineration costs.

Table 1.10: Example of the comparative individual cost elements for MSW and HW incineration plants

Cost structure	Incineration plant for	
	Municipal waste with a capacity of 250 ktonnes/yr in EUR 10 ⁶	Hazardous waste with a capacity of 70 ktonnes/yr in EUR 10 ⁶
Planning/approval	3.5	6
Machine parts	70	32
Other components	28	28
Electrical works	18	20
Infrastructure works	14	13
Construction time	7	7
Total investment costs	140	105
Capital financing cost	14	10
Personnel	4	6
Maintenance	3	8
Administration	0.5	0.5
Operating resources/energy	3	2.5
Waste disposal	3.5	1.5
Other	1	0.5
Total operational costs	29	12.5
Specific incineration costs (without revenues)	Approx. EUR 115/tonne	Approx. EUR 350/tonne
NB: The data provide an example in order to illustrate differences between MSWI and HWI. The costs of each and the differential between them vary. Source: [1, UBA 2001], [64, TWG 2003]		

Energy prices

[43, Eunomia 2001] Revenues are received for energy sales. The level of support per kWh for electricity and/or heat generation varies greatly. For example, in Sweden and Denmark, gate fees are lower, at least in part because of the revenue gained from the sales of thermal energy as well as electricity. Indeed, in Sweden the generation of electricity is often not implemented due to the considerable revenues for heat recovery.

In some other countries, support for electricity production has encouraged electricity recovery ahead of heat recovery. The UK, Italy and Spain, amongst others, have at some stage supported incineration through elevated prices for electricity generated from incinerators.

In other MSs, the structure of incentives available for supporting renewable energy may also affect the relative prices of alternative waste treatments and hence competition prices.

The potential revenues from energy sales at waste incineration facilities constitute an incentive for all parties concerned to include energy outlets in the planning phase for incineration facilities [64, TWG 2003].

Revenues received for recovery of packaging materials

[43, Eunomia 2001] These have also influenced relative prices. For example, in Italy, France and the UK, incinerators have received revenues associated with the recovery of packaging material.

It should be noted that legislative judgements concerning recovery and disposal may influence whether incinerators can legally benefit from these revenues [64, TWG 2003]

Taxes on incineration

[43, Eunomia 2001] In Denmark, the tax on incineration is especially high. Hence, although the underlying costs tend to be low (owing primarily to scale, and the prices received for energy), the costs net of tax are of the same order as those of several other countries where no tax is in place. This tax, along with a landfill tax, was adopted in Denmark to promote waste treatment in compliance with the waste hierarchy. This has resulted in a large shift from landfill to recycling, but with the percentage of waste being incinerated remaining constant [64, TWG 2003].

2 APPLIED PROCESSES AND TECHNIQUES

2.1 Overview and introduction

A typical waste incineration plant will include the following operations:

- incoming waste reception;
- storage of waste and raw materials;
- pre-treatment of waste (where required, on site or off site);
- loading of waste into the process;
- thermal treatment of the waste;
- energy recovery (e.g. boiler) and conversion;
- flue-gas cleaning (FGC);
- flue-gas cleaning residue management;
- flue-gas discharge;
- emissions monitoring and control;
- waste water control and treatment (e.g. from site drainage, flue-gas cleaning, storage);
- ash/bottom ash management and treatment (arising from the combustion stage);
- solid residue discharge/disposal.

Each stage will be designed for the specific type(s) of waste treated at the installation. Information describing these stages is included later in this chapter.

Many installations operate continuously, 24 hours a day, nearly 365 days a year. Control systems and maintenance programmes play an important role in securing the availability of the plant. [74, TWG 2004]

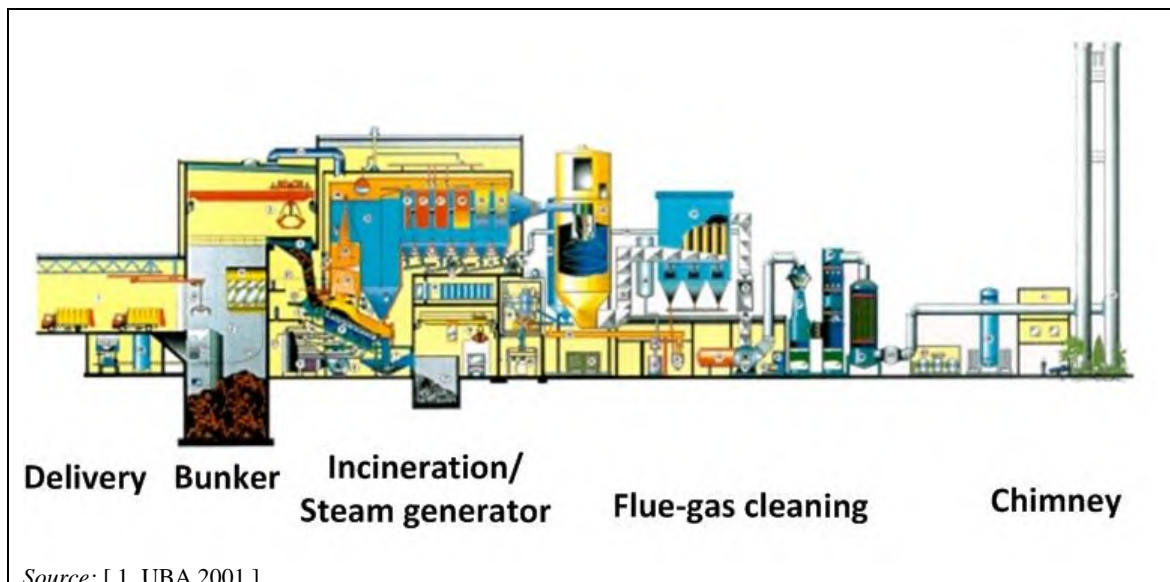

Figure 2.1: Example layout of a municipal solid waste incineration plant with a wet FGC system

There are three main types of thermal waste treatment:

- **combustion** - full oxidative combustion (by far the most common process);
- **pyrolysis** - thermal degradation of organic material in the absence of oxygen;
- **gasification** - partial oxidation.

The reaction conditions and products of these thermal treatments are shown in Table 2.1.

Table 2.1: Typical reaction conditions and products from combustion, pyrolysis and gasification processes

	Combustion	Pyrolysis	Gasification
Reaction temperature (°C)	800–1 450	250–700	500–1 600
Pressure (bar)	1	1	1–45
Atmosphere	Air	Inert/Nitrogen	Gasification agent: O ₂ , H ₂ O
Stoichiometric ratio	> 1	0	< 1
Products from the process in the			
• gas phase:	CO ₂ , H ₂ O, O ₂ , N ₂	H ₂ , CO, hydrocarbons, H ₂ O, N ₂	H ₂ , CO, CO ₂ , CH ₄ , H ₂ O, N ₂
• solid phase:	Ash, slag	Ash, coke	Slag, ash
• liquid phase:		Pyrolysis oil and water	
<i>Source: Adapted from [9, VDI 2002]</i>			

- Pyrolysis and gasification plants follow a similar basic structure to waste incineration plants but there are some significant differences: **pre-treatment**, may be more extensive to provide a narrow profile feedstock and additional equipment is required for handling, treating and storing the rejected material;
- **loading**, greater attention required to sealing;
- **thermal reactor**, to replace (or in addition to) the combustion stage;
- **product handling**, gaseous and solid products require handling, storage and possible further treatments;
- **product combustion**, may be a separate stage and include energy recovery by combustion of the products and subsequent gas/water/solid treatments and management.

2.2 Pre-treatment, storage and handling techniques

The different types of wastes that are incinerated may need different types of pre-treatment, storage and handling operations. This section describes the most relevant of these operations for the following wastes:

- municipal solid waste and similar;
- hazardous waste;
- sewage sludge;
- clinical waste.

2.2.1 Municipal solid waste and similar (MSW)

2.2.1.1 Collection and pre-treatment outside the MSW incineration plant

Although beyond the immediate scope of this document, it is important to recognise that the local collection and pre-treatment applied to MSW will strongly influence the nature of the material received at the incineration plant. The pre-treatment and other operations carried out at the incinerator should therefore be consistent with the collection system in place.

Recycling schemes may mean that some fractions have been removed. Their effect will be roughly as follows.

Table 2.2: Main impacts of waste selection and pre-treatment on residual waste

Fraction removed	Main impacts on remaining waste
Glass and metals	<ul style="list-style-type: none"> • Increase in calorific value • Decrease in quantity of recoverable metals in slag
Paper, card and plastic	<ul style="list-style-type: none"> • Decrease in calorific value • Possible reduction in chlorine loads if PVC common
Organic wastes, e.g. food and garden wastes	<ul style="list-style-type: none"> • Reduction in moisture loads (particularly of peak loads) • Increase in net calorific value
Bulky wastes	<ul style="list-style-type: none"> • Reduced need for removal/shredding of such wastes
Hazardous wastes	<ul style="list-style-type: none"> • Reduction in hazardous metal loading, including Hg • Reduction in the loading of some other substances, e.g. Cl, Br
<i>Source: [74, TWG 2004]</i>	

One study assessing the effect of selective collection on the remaining household waste (called 'grey waste') gave the following conclusions:

- Glass collection decreased the throughput (-13 %) and increased the calorific value (+15 % LHV) of the residual 'grey waste'.
- Packaging and paper collection decreased the throughput (-21 %) and the LHV (-16 %) of the 'grey waste'.
- In general, the throughput and LHV of the 'grey waste' decreased when the efficiency of the selective collection increased. The maximum impact of selective collection was -42 % for the throughput and -3 % for the LHV of the 'grey waste'.
- Selective collection had an effect on the grey waste quality - it significantly increased the content of the fine fraction which can be particularly rich in heavy metals (fines increased from 16 % to 33 %).
- The bottom ash ratio decreased due to selective collection (-3 %).

[74, TWG 2004]

The degree to which separate collection and similar schemes affect the final waste delivered to the installation depends on the effectiveness of the separation and pre-treatment systems employed. This varies greatly. Some residual fractions are always likely to remain in the delivered waste.

Reject materials from recycling plants, mono-streams of waste, commercial and industrial wastes, and some hazardous wastes may also be part of the delivered waste.

2.2.1.2 Municipal solid waste pre-treatment within the incineration plant

In-bunker mixing is commonly used to blend MSW. This usually involves using the same waste grab used for hopper loading. Most commonly, the pre-treatment of MSW is limited to the shredding of pressed bales, bulky waste, etc., although sometimes more extensive shredding is carried out using:

- crocodile shears;
- shredders;
- mills;
- rotor shears.

For fire-safety reasons, the following arrangements may be used:

- separation of the dumping areas from the storage in the bunker;
- separation of hydraulic plants (oil supply, pump and supply equipment) from the cutting tools;
- collection devices for leaked oil;
- decompression release in the housing to reduce explosion damage.

Bulky waste is usually pretreated by crushing when it is bigger than the system that feeds it to the furnace. Pre-treatment by crushing, shredding and/or mixing is also carried out to homogenise the waste so that it has more consistent combustion characteristics (e.g. for some wastes with a high LHV). Additional waste pre-treatment is unusual for grate furnace plants, but may be essential for other furnace designs.

2.2.1.3 Waste delivery and storage

The general principles of storage are described in the BREF on Emissions from Storage (EFS BREF), published in July 2006. Waste delivery, storage and handling are also addressed by the BREF on Waste Treatment (WT). This section serves to outline some issues that are specific to MSW.

2.2.1.3.1 Waste control

The waste delivery area is where the delivery trucks, trains or containers arrive in order to dump the waste into the bunker, usually after visual control and weighing. The dumping is carried out through openings between the delivery area and the bunker. Tilting and sliding beds may be used to facilitate waste transfer to the bunker. The openings can be closed to prevent the escape of odours, act as a firebreak and reduce the risk of vehicle accidents. Enclosure of the delivery area can be effective in reducing odour, noise and emission problems from the waste.

2.2.1.3.2 Bunker

The bunker is usually a waterproof, concrete chamber. The waste is piled and mixed in the bunker using cranes equipped with grapples. The mixing of wastes helps to achieve a balanced heat value, size, structure, composition, etc. of the material dumped into the incinerator filling hoppers.

Fire protection equipment is used in the bunker area and feeder system, for example:

- fireproofed cabling for the cranes;
- safety design for the crane cabs;
- fire detectors;
- automatic water cannon sprays, with or without foam.

Crane cabs are designed to provide the crane operator with a good view of the entire bunker. The cab has its own ventilation system, independent from the bunker.

The air for the furnaces is often extracted from the bunker area to remove dust and odours and any methane generated by fermentation of the wastes. The calorific value of the waste as well as the layout and the concept of the plant will determine whether the air from the bunker is used as primary air, secondary air or both. [74, TWG 2004]

The bunker usually has a storage capacity of 3 to 5 days of plant operational throughput. This is very dependent on local factors and the specific nature of the waste.

Additional safety devices may be implemented such as: dry standpipe at the waste hopper level, foam nozzle above the waste hopper, fire detection for the hydraulic group, fire-resistant walls between the bunker and the furnace hall, fire-resistant walls between the furnace hall and the control room, water curtains on the window between the control room and the furnace, smoke and fire extraction (5–10 % of the surface of the roof).
[74, TWG 2004]

2.2.2 Hazardous waste

The hazardous waste incineration sector comprises two main subsectors:

- merchant incineration plants;
- dedicated incineration plants.

The main differences between these are summarised in the table below.

Table 2.3: Summary of the differences between operators in the HWI market

Criteria	Merchant plants	Dedicated plants
Ownership	Private companies, municipalities or partnerships	Usually private companies (used for their own wastes)
Characteristics of wastes treated	<ul style="list-style-type: none"> • Very wide range of wastes • Knowledge of exact waste composition may be limited in some cases 	<ul style="list-style-type: none"> • Wide range of wastes, but mainly liquid and gaseous wastes • Often the waste only originates from one company or even from one process • Knowledge of waste composition generally higher
Combustion technologies applied	<ul style="list-style-type: none"> • Predominantly rotary kilns • Some dedicated technologies for dedicated or restricted specification wastes 	<ul style="list-style-type: none"> • Mainly static kilns • A wide variety of specific techniques for dedicated or restricted specification wastes
Operational and design considerations	<ul style="list-style-type: none"> • Flexibility and wide range of performance required to ensure good process control 	<ul style="list-style-type: none"> • Process can be more specifically designed for a narrower specification of feed in some cases
Flue-gas cleaning	<ul style="list-style-type: none"> • Wet scrubbing often applied to give flexibility of performance • A range of FGC techniques (often applied in combination with wet scrubbing) 	<ul style="list-style-type: none"> • Wet scrubbing often applied to give flexibility of performance • A range of FGC techniques (often applied in combination with wet scrubbing)
Cost/market considerations	<ul style="list-style-type: none"> • Operators usually compete in an open (global) market for business • Some plants benefit from national/regional policies regarding the destination of wastes arising in that country/region • Movement of hazardous waste in the EU is controlled by Transfrontier Shipment Regulations which limits the scope of open global market 	<ul style="list-style-type: none"> • Competition more limited or in some cases non-existent • Higher disposal costs tolerated by users in some cases for reasons of waste producer policy on in-house disposal
<i>Source: Discussions with TWG</i>		

[41, EURITS 2002]. The individual incineration capacity of rotary kilns used in the merchant sector varies between 25 000 tonnes and 140 000 tonnes a year. The mass capacity for an individual design varies considerably with the average calorific value of the waste, with the principal factor being thermal capacity.

The following sections refer mainly to the delivery, storage and pre-treatment of hazardous waste for the merchant sector.

2.2.2.1 Waste acceptance

Due to the very wide variety of wastes encountered, their high potential hazardousness, and elevated uncertainties over the precise knowledge of the waste composition, significant effort is required to assess, characterise and trace incoming wastes through the entire process. The systems adopted need to provide a clear audit trail that allows the tracing of any incidents to their source. This then enables procedures to be adapted to prevent further incidents.

The exact procedures required for waste acceptance and storage depend on the chemical and physical characteristics of the waste.

Identification and analysis of wastes

[1, UBA 2001] For each type of hazardous waste, a declaration of the nature of the waste made by the waste producer is submitted so that the waste manager can then decide on the appropriate storage and treatment required. Such a declaration may include:

- data on the waste producer and responsible persons;
- data on the waste code and other designations for the waste;
- data on the origin of the waste;
- analytical data on particular toxic materials;
- general characteristics, including combustion parameters, such as Cl, S, calorific value, water content;
- other safety/environmental information;
- legally binding signature;
- additional data upon request of the accepting plant.

Some types of waste require additional measures. Homogeneous, production-specific waste can often be adequately described in general terms. Additional measures are usually required for waste of a less well-known composition (e.g. waste from refuse dumps or from the collections of hazardous household waste), including the inspection of each individual waste container.

When the waste composition cannot be described in detail (e.g. small amounts of pesticides or laboratory chemicals), the waste management company may agree with the waste producer on specific packaging requirements, making sure that the waste will not react during transport, when it is accepted for incineration, or within containers. For example, risks may arise from:

- wastes with phosphides;
- wastes with isocyanates;
- wastes with alkaline metals (for example, or other reactive metals);
- cyanide with acids;
- wastes forming acid gases during combustion;
- wastes with mercury.

[74, TWG 2004]

Delivered wastes generally undergo specific waste acceptance controls, which may include detailed laboratory analyses depending on the volume and nature of the waste. Visual and analytical investigations of the waste are compared with the data contained in the declaration received from the waste producer. The waste is either accepted and allocated to the appropriate storage area, or rejected in the case of significant deviations.

2.2.2.2 Storage

The general principles of storage are described in the BREF on Emissions from Storage (EFS BREF), published in July 2006. Waste delivery, storage and handling are also addressed by the BREF on Waste Treatment (WT). However, this section serves to outline some issues that are specific to the incineration of hazardous waste.

In general, the storage of wastes needs, additionally, to take into account the unknown nature and composition of wastes, as this gives rise to additional risks and uncertainties. In many cases, this uncertainty means that higher specification storage systems are applied for wastes than for well-characterised raw materials.

A common practice is to ensure, as far as possible, that hazardous wastes are stored in the same containers (drums) that are used for transportation, thus avoiding the need for additional handling and transfer. Good communication between the waste producer and the waste manager help to ensure wastes are stored, transferred, etc. such that risks all along the chain are well managed. It is also important that only well-characterised and compatible wastes are stored in tanks or bunkers.

Hazardous waste storage arrangements may need to comply with the Seveso III Directive on the control of major accident hazards, as well as BAT described in the EFS BREF and/or the WT BREF. There may be circumstances where the prevention/mitigation measures for major accident hazards take precedence.

[41, EURITS 2002] Appropriate waste assessment is an essential element in the selection of storage and loading options. Some issues to note are the following:

- For the storage of **solid hazardous waste**, many incinerators are equipped with a bunker (500–2 000 m³) from where the waste is fed into the installation by cranes or feed hoppers.
- For **liquid hazardous waste and sludges**, which are usually stored in a tank farm, some tanks have storage under an inert (e.g. N₂) atmosphere. Liquid waste is pumped via pipelines to the burners and introduced into the rotary kiln and/or the post-combustion chamber (PCC). Sludges can be fed to rotary kilns using special 'viscous-matter' pumps.
- Some incinerators are able to feed certain substances, such as toxic, odorous, reactive and corrosive liquids, by means of a **direct injection** device, directly from the transport container into either the kiln or the PCC.
- Almost half of the merchant incinerators in Europe are equipped with conveyors and elevators to transport and introduce **drums** and/or small packages (e.g. lab packs) directly into the rotary kiln. These may be via airlock systems and can use inert gas flood systems.

2.2.2.2.1 Storage of solid hazardous waste

[1, UBA 2001] Solid and unpumpable pasty hazardous waste that has not been degassed and does not smell is stored temporarily in bunkers. Storage and mixing areas can be separated in the bunker. This can be achieved through several design segments. Cranes feed both solid and pasty waste products. The bunker must be designed to prevent emissions into the ground.

The bunker and container storage should be enclosed unless there are health and safety reasons for not enclosing them (e.g. danger of explosion and fire). Combustion air for the incinerator is usually taken from the waste storage area to prevent emissions of dust and odours. Waste storage areas should be constantly monitored to ensure the early detection of any fires. Visual monitoring by the control room operator and/or crane operator can be supported by the use of heat-detecting cameras.

2.2.2.2 Storage of pumpable hazardous waste

[1, UBA 2001] Larger amounts of fluid and pumpable pasty wastes are temporarily stored in tanks. Sufficient numbers and sizes of tanks must be available to accommodate separate storage of incompatible types of waste (e.g. oxidisers stored separately from flammable materials to prevent fires/explosions, and acids stored separately from sulphides to prevent hydrogen sulphide production).

Tanks, pipelines, valves and seals must be adapted to the waste characteristics in terms of construction, material selection, and design. They must be sufficiently corrosion-proof and offer the option of cleaning and sampling. Flat-bed tanks are generally only deployed for large loads.

It may be necessary to homogenise the tank contents with mechanical or hydraulic agitators. Depending on the waste characteristics, the tanks must be heated indirectly and insulated. Tanks are set in catch basins that must be designed for the stored material, with bund volumes chosen so that they can hold the liquid waste in the event of leakage.

2.2.2.3 Storage of containers and tank containers

[1, UBA 2001] For safety reasons, hazardous waste is most often accumulated in special containers. These containers are then delivered to the incineration plant. Delivery of bulk liquids is also taken.

The delivered containers may be stored or the contents transferred. In some cases, according to a risk assessment, the waste may be directly injected via a separate pipeline into the furnace. Heated transfer lines may be used for wastes that are only liquid at higher temperatures.

Storage areas for containers and tank containers are usually located outside, with or without roofs. Drainage from these areas is generally controlled, as contamination may arise.

2.2.2.3 Feeding and pre-treatment

The wide range of chemical and physical properties of some hazardous wastes may cause difficulties in the incineration process. Some degree of waste blending or specific pre-treatment is often carried out to produce a more consistent feed material.

[2, InfoMil 2002]

Each installation develops waste acceptance criteria that specify the allowable ranges for the key combustion and chemical properties of incoming wastes. The application of these criteria ensures that the process operates steadily and predictably to comply with operational and environmental (e.g. permit conditions) requirements.

Factors that set such ranges include:

- the capacity of the flue-gas cleaning system for individual pollutants (e.g. scrubber flow rates);
- the presence or absence of a particular flue-gas cleaning technique;
- heat throughput rating of the furnace;
- design of the waste feed mechanism and the physical suitability of the waste received.

[41, EURITS 2002] Some incinerators have dedicated and integrated homogenisation processes for the pre-treatment of waste. These include the following:

- A shredder for bulky solids (e.g. contaminated packages) [74, TWG 2004].
- A dedicated shredder purely for drums. Depending on the installation, drums containing solid and/or liquid waste can be treated. The shredded residues are then fed via the bunker and/or tanks. A shredder combined with a mechanical mixing device. This results in a homogenised fraction which is pumped directly into the kiln by means of a thick-matter pump. Some shredders can deal with both drums and/or solid waste in packages of up to 1 tonne.

Other forms of pre-treatment may be carried out depending on the waste composition and the individual characteristics of the incineration plant, for example [1, UBA 2001]:

- neutralisation (for waste acceptance, pH values from 4 to 12 are normal);
- sludge drainage;
- solidification of sludge with binding agents.

Figure 2.2 shows two hazardous waste pre-treatment systems used at merchant hazardous waste incinerators (HWIs).

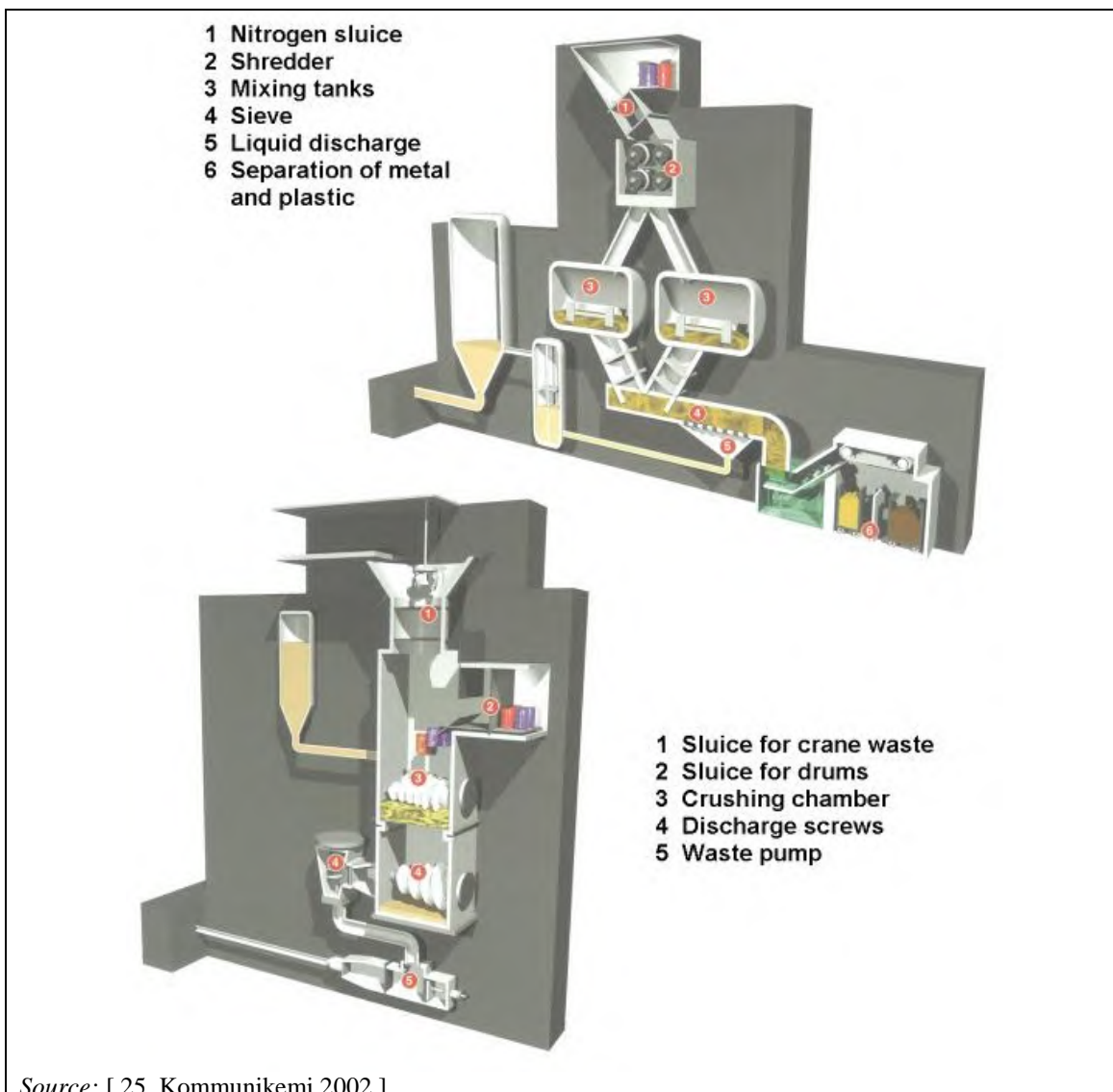

Source: [25, Kommunikemi 2002]

Figure 2.2: Examples of hazardous waste pre-treatment systems used at some merchant HWIs

2.2.3 Sewage sludge

2.2.3.1 Composition of sewage sludge

The composition of sewage sludge varies according to many factors, including:

- system connections, e.g. industrial inputs can increase heavy metal loads;
- coastal locations, e.g. for salt water inclusion;
- treatments carried out at the treatment works, e.g. crude screening only, anaerobic sludge digestion, aerobic sludge digestion, addition of treatment chemicals;
- weather/time of year, e.g. rainfall can dilute the sludge.
- The composition of sewage sludge varies greatly. Typical composition ranges for dewatered communal and industrial sewage sludge are given below.

Table 2.4: Average composition of dewatered communal sewage sludge and industrial sewage sludge after dewatering

Component	Communal sewage sludge	Industrial sewage sludge
Dry solids (%)	10–45	
Organic material (% of dry solids)	45–85	
Metals (mg/kg of dry solids):		
Cr	20–77	170
Cu	200–600	1 800
Pb	100–700	40
Ni	15–50	170
Sb	1–5	< 10
Zn	500–1 500	280
As	5–70	< 10
Hg	0.5–4.6	1
Cd	1–5	< 1
Mo	4–20	
<i>Source: [2, InfoMil 2002], [64, TWG 2003], FEAD comments in [7, TWG 2017]</i>		

Sewage sludge also contains phosphorus generally in the range 1-2.5 % dry matter, depending on whether or not the sewage works operate phosphorus removal and on the pre-treatment. There is thus an opportunity for phosphorus recovery either upstream of sewage sludge incineration or from the incineration ashes. [138, Bezak-Mazur et al, 2014]

Important factors to take into account when incinerating sewage sludge are:

- the dry solids content (typically this varies from 10 % up to 45 % - this has major implications for the incineration process);
- whether the sludge is digested or not;
- the lime, limestone and other conditioning contents of the sludge;
- the composition of the sludge as primary-, secondary-, bio-sludge, etc.;
- odour problems, especially during sludge feeding in the storage areas.

[64, TWG 2003] [74, TWG 2004]

2.2.3.2 Pre-treatment of sewage sludge

Different types of pre-treatment are applied to sewage sludge. Some are specifically connected to the incineration properties of the material (in particular, processes for the reduction of the water content of the sludge), while others can have different purposes, including for the recovery of the resources contained in the raw sludge (e.g. biogas, phosphorous), and may have a more or less pronounced influence on the ensuing incineration process [143, Healy et al. 2015]. The following sub-sections describe some commonly applied sludge pre-treatment processes.

2.2.3.2.1 Physical dewatering

[1, UBA 2001], [64, TWG 2003]

Mechanical drainage before incineration reduces the volume of the sludge mixture, and increases the heat value. This allows independent and economical incineration. The success of mechanical drainage depends on the selected machines, the conditioning carried out, and the type and composition of the sludge.

Through mechanical drainage of the sewage sludge in decanters, centrifuges, belt filter presses and chamber filter presses, a dry solids (DS) level of between 10 % and 45 % can be achieved. Often the sludge is conditioned before the mechanical drainage to improve its drainage. This is achieved with the help of additives that contain flock-building materials. It is necessary to differentiate between inorganic flocking substances (iron and aluminium salts, lime, coal, etc.) and organic flocking substances (organic polymers). Inorganic substances not only act as flocking substances but are also builders, i.e. they increase the inorganic content substantially, and hence increase the amount of ash produced. Organic conditioning substances are generally preferred because they are destroyed in the incinerator and do not increase the amount of ash produced.

2.2.3.2.2 Drying

[1, UBA 2001], [64, TWG 2003]

Often, a substance that has been dried by mechanical drainage is still too wet for auto-thermal incineration. A thermal drying plant can be used to increase the heat value and reduce the volume of the sludge before the incineration furnace.

The drying/dewatering of sewage sludge is carried out in separate or connected drying plants. The following dryer plants are utilised:

- disk dryer;
- drum dryer;
- fluidised bed dryer;
- belt dryer;
- thin film dryer/disk dryer;
- cold air dryer;
- thin film dryer;
- centrifugal dryer;
- solar dryer;
- combinations of different types.

Drying processes can be divided into two groups:

- partial drying, up to approximately 60–80 % dry solids;
- complete drying, up to approximately 80–90 % dry solids.

[74, TWG 2004]

An alternative to external drying is the *in situ* drying of sludge by incineration together with higher calorific waste. In such cases, the water from the dewatered sludge helps to prevent the high temperature peaks that could be seen if high-CV waste was incinerated on its own.

For auto-thermal incineration in sewage sludge mono-incineration plants, the drainage of raw sewage up to 35 % dry solids is generally sufficient. This can be achieved by mechanical dewatering and may not require thermal drying.

The required dry solids content for auto-thermal incineration in a given installation will depend on the composition of the sludge (energy content of the dry solids, largely related to the content of organic material). This is influenced by the nature of the sludge and any pre-treatments that are applied, e.g. sludge digestion, or the use of organic or inorganic sludge conditioners.

Depending on its moisture level and on the overall share of sludge that is co-combusted, sludge drying may be required to enable the simultaneous incineration of sewage sludge with other waste streams in municipal waste incineration plants. Typical operating conditions for the MSWI feed are around 10 % drained sewage sludge with 20–30 % dry solids.

[74, TWG 2004]

The heat required for the drying process is usually extracted from the incineration process. In direct drying processes, the sewage sludge comes into direct contact with the thermal carrier (e.g. in convection, belt, double-deck and fluidised bed dryers. The drying process produces a mixture of steam, air, and gases released from the sludge which is generally injected into the furnace.

In indirect drying systems (e.g. worm, disk, thin film dryers), the heat is injected via steam generators or thermal oil plants and the heating fluid is not in contact with the sludge. Heat transfer occurs between the wall and the sludge.

Contact dryers generally achieve a dry solids level of 35–40 %. The evaporated water produced through the drying process is only contaminated with leaking air and small amounts of volatile gases. The steam can be condensed almost totally from the vapour and the remaining inert gases can be used as incinerator feed air to prevent the emission of odours. The treatment of the condensate may be complicated due to the presence of NH_4OH , TOC, etc.

2.2.3.2.3 Sludge digestion

Sludge digestion decreases the organic content of the sludge, and anaerobic digestion also produces biogas. Digested sludge can generally be dewatered more easily than non-digested sludge, producing a slightly higher dry solids content.

[64, TWG 2003]

2.2.4 Clinical waste

2.2.4.1 Nature and composition of clinical wastes

Special attention is required when dealing with clinical wastes to manage the specific risks (e.g. infectious contamination, needles), the aesthetic standards (residues of operations, etc.) and their incineration behaviour (very variable calorific value and moisture contents).

Specific clinical waste often contains materials with a very high LHV (plastics, etc.), but also residues with a very high water content (e.g. blood). Clinical waste therefore usually requires long incineration times to ensure thorough waste burnout and acceptable residue quality.

Similar to hazardous wastes, the composition of clinical wastes varies greatly and may include:

- infectious agents;
- contaminated clothing/wipes and swabs;
- pharmaceutical substances;
- sharp materials, e.g. hypodermic needles;
- veterinary wastes;
- body parts;
- used medical equipment;
- packaging materials;
- laboratory wastes;
- radioactive contaminated materials.

In some cases, a distinction is made between the incineration routes for pathological (potentially infectious waste) and non-pathological waste. The treatment of pathological waste is sometimes restricted to dedicated incinerators, while non-pathological waste is, in some cases, incinerated with other wastes in non-dedicated incinerators, e.g. MSWIs.

2.2.4.2 Handling, pre-treatment and storage of clinical waste

The risks associated with the handling of clinical waste can generally be reduced by limiting contact with the waste and by ensuring good storage conditions through the use of:

- dedicated containers and the provision of washing/disinfection facilities;
- sealed and robust combustible containers, e.g. for sharps and biological hazard materials;
- automatic furnace-loading systems, e.g. dedicated bin lifts;
- segregated storage and transfer areas (especially where co-incineration with other wastes takes place);
- refrigerated or freezer storage, if required.

Pre-treatment may be carried out using:

- steam disinfection, e.g. autoclaving at elevated temperature and pressure;
- boiling with water.

Each of these may allow the waste to be sufficiently sterilised to permit its subsequent handling in a similar manner to municipal wastes. Work and storage areas are usually designed to facilitate disinfection.

Appropriate cleaning and disinfection equipment is usually installed for the cleaning of returnable containers. The solid wastes from disinfection are collected for disposal. The waste water from disinfection is collected and then recycled in the incineration process (e.g. in the FGC or with the waste feed) or treated and discharged. [74, TWG 2004]

Pre-treatment may be applied to improve the homogeneity of the waste, such as shredding or maceration, although safety aspects require careful consideration with some clinical wastes.

Clinical waste is also incinerated in hazardous waste and other incineration plants with other types of waste. If incineration does not take place immediately, the wastes require temporary storage. In some cases, where it is necessary for clinical waste to be stored for longer than 48 hours, the waste is kept in cooled storage areas with a restricted maximum temperature (e.g. +10 °C).

2.3 The thermal treatment stage

Different types of thermal treatments are applied to the different types of wastes. This chapter and Table 2.5 review the concepts and applications behind the most common technologies, in particular:

- grate incinerators;
- rotary kilns;
- fluidised beds;
- pyrolysis and gasification systems.

They also cover some other more specific technologies.

[6, EGTEI 2002]

Municipal solid waste can be incinerated in travelling grates, rotary kilns and fluidised beds. Fluidised bed technology requires MSW to be of a certain particle size range, which usually requires some degree of pre-treatment even when the waste is collected separately.

Sewage sludge can be incinerated in rotary kilns, multiple hearth or fluidised bed incinerators. Co-combustion in grate firing systems, coal combustion plants and industrial processes is also applied. Sewage sludge often has a high water content and therefore usually requires drying or the addition of supplementary fuels to ensure stable and efficient combustion.

Hazardous and clinical waste is usually incinerated in rotary kilns but grate incinerators (including co-firing with other wastes) are sometimes applied to solid wastes, and fluidised bed incinerators to some pretreated materials. Static furnaces are also widely applied at on-site facilities in chemical plants.

Other processes have been developed that are based on the decoupling of the phases which take place in an incinerator: drying, volatilisation, pyrolysis, carbonisation and oxidation of the waste. Gasification using gasifying agents such as steam, air, carbon oxides or oxygen is also applied. These processes aim to reduce flue-gas volumes and associated flue-gas treatment costs. Some of these processes encountered technical and economic problems when they were scaled up to commercial, industrial sizes, and their development has been abandoned. Some are used on a commercial basis (e.g. in Japan) and others are being tested in demonstration plants throughout Europe, but they still have only a small share of the overall treatment capacity when compared to incineration.

Table 2.5: Summary of the current application of thermal treatment processes applied to different waste types

Technique	Municipal solid waste	Other non-hazardous waste	Hazardous waste	Sewage sludge	Clinical waste
Grate - intermittent/reciprocating	56 %	43 %	0 %	0 %	0 %
Grate - vibration	0 %	0 %	11 %	0 %	0 %
Grate - moving	24 %	27 %	0 %	0 %	0 %
Grate - roller	12 %	10 %	0 %	0 %	0 %
Grate - water-cooled	22 %	48 %	17 %	0 %	0 %
Grate plus rotary kiln	0.5 %	0 %	2 %	0 %	0 %
Rotary kiln	2 %	0 %	70 %	0 %	0 %
Static hearth	0 %	0 %	0 %	0 %	67 %
Static furnace	0 %	0 %	16 %	0 %	0 %
Fluidised bed - bubbling	2 %	13 %	0 %	90 %	0 %
Fluidised bed - circulating	3 %	8 %	0 %	10 %	0 %
Pyrolysis	0 %	0 %	0 %	0 %	0 %
Gasification	0.5 %	0 %	0 %	0 %	33 %

NB: This table shows the technologies applied at the plants participating in the 2016 data collection for the WI BREF review, classified by the prevalent type of waste incinerated in 2014.
Source: [81, TWG 2016]

2.3.1 Grate incinerators

Grate incinerators are widely applied for the incineration of mixed municipal wastes. In Europe, approximately 90 % of installations treating MSW use grates. Other wastes commonly treated in grate incinerators, often as additions with MSW, include commercial and industrial non-hazardous wastes, sewage sludges and certain clinical wastes.

Grate incinerators usually have the following components:

- waste feeder;
- incineration grate;
- bottom ash discharger;
- incineration air duct system;
- incineration chamber;
- auxiliary burners.

Figure 2.3 shows an example of a grate incinerator with a heat recovery boiler.

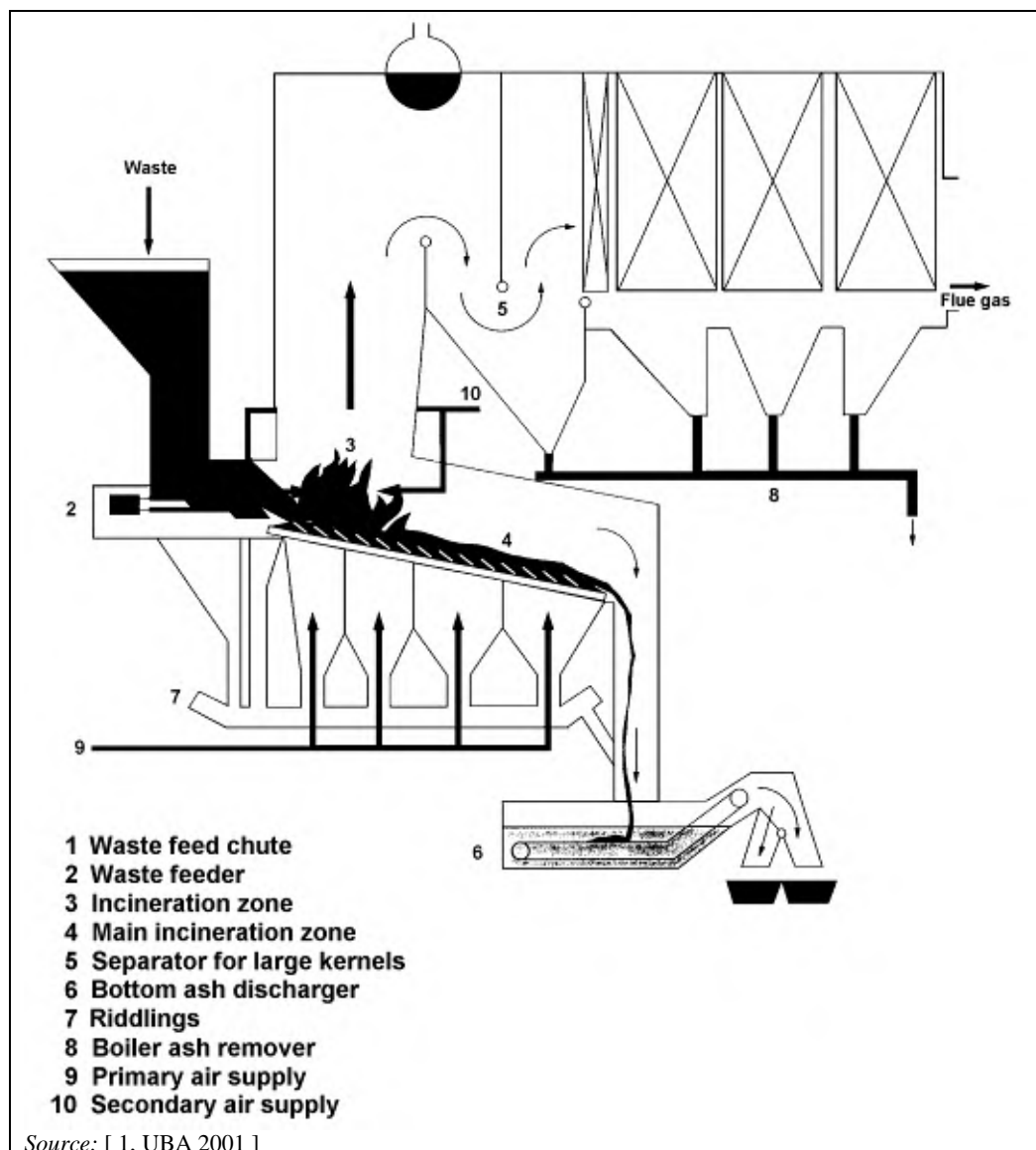

Figure 2.3: Grate, furnace and heat recovery stages of an example municipal waste incineration plant

2.3.1.1 Waste feeder

The waste is discharged from the storage bunker into the feeding chute by an overhead crane, and then fed into the grate system by a hydraulic ramp or another conveying system. The grate moves the waste through the various zones of the combustion chamber in a tumbling motion.

The filling hopper is used as a continuous waste supplier. It is filled in batches by the overhead crane. As the filling hopper surface is exposed to great stress, materials with high friction resistance are selected (e.g. boilerplates or wear-resistant cast iron). The material must survive occasional hopper fires unscathed.

The waste hopper may sometimes be fed by a conveyor. In that case, the overhead crane discharges waste into an intermediate hopper that feeds the conveyor. [74, TWG 2004]

If the delivered waste has not been pretreated, it is generally very heterogeneous in both size and nature. The feed hopper is therefore dimensioned in such a way that bulky materials fall through and bridge formations and blockages are avoided. These blockages must be avoided as they can result in uneven feeding to the furnace and uncontrolled air ingress to the furnace.

Feeder chute walls can be protected from heat by using:

- water-cooled double shell construction;
- membrane wall construction;
- water-cooled stop valves;
- fireproof brick lining.

If the feed chute is empty, stop valve equipment (e.g. door seals) can be used to avoid flashbacks and to prevent uncontrolled air infiltration into the furnace. A uniform amount of waste in the filling chute is recommended for uniform furnace management.

The junction between the lower end of the filling chute and the furnace consists of a dosing mechanism. The dosing mechanism may be driven either mechanically or hydraulically. Its feeding rate is generally adjustable. Different construction methods have been developed for the various types of feeder systems, such as:

- chain grates/plate bands;
- feeder grates;
- variable taper feed chutes;
- RAM feeders;
- hydraulic ramp;
- feed screws.

[74, TWG 2004]

2.3.1.1.1 Addition of sewage sludge to a municipal waste incinerator

Sewage sludge is sometimes incinerated with other wastes in municipal grate incineration plants (see Section 2.3.3 for information regarding the use of fluidised beds and other technologies).

Where added to a MSWI, it is often the feeding techniques that represent a significant proportion of the additional investment costs.

The following three supply technologies are used:

- Dried sewage sludge (~ 90 % dry solids) is blown as dust into the furnace.
- Drained sewage sludge (~ 20–30 % dry solids) is supplied separately through sprinklers into the incineration chamber and distributed on a grate. The sludge is integrated into the bed material by overturning the waste on the grates. Some operational experiences have shown that up to 20 mass-% sludge (at 25 % dry solids) can be incinerated using this technique. Other experiences have shown that if the sludge ratio is too high (e.g. > 10 %), a high fly ash content or unburnt material in bottom ash may occur.
- Drained, dried or partially dried sludge (~ 50–60 % dry solids) is added to the municipal waste and the mixture is fed into the incineration chamber. Mixing can occur in the waste bunker through targeted doses by the crane operator, or it can be controlled in a feeding hopper by pumping dewatered sludge into the hopper or into the bunker by spreading systems. [74, TWG 2004]

2.3.1.1.2 Addition of clinical waste to a municipal waste incinerator

[49, Denmark 2002] Clinical waste is sometimes incinerated with other wastes in municipal waste incineration plants. Clinical waste is combusted in the same furnace as the MSW.

Infectious clinical waste is placed straight into the furnace, without first being mixed with other categories of waste and without direct handling. A separate loading system with airlocks is used. The airlock helps to prevent the uncontrolled entry of combustion air and the possibility of fugitive emissions in the loading area.

The combined incineration of clinical waste with municipal solid waste can be carried out without a separate loading system. For example, automatic loading systems can be used to put the clinical waste directly into the feed hopper with MSW.

National regulations sometimes limit the ratio of clinical waste that may be treated in combined incineration (e.g. in France < 10 % thermal load).

Flue-gases from the different wastes are then treated in common FGC systems.

In Figure 2.4 below the order of the stages for a separate loading system are shown.

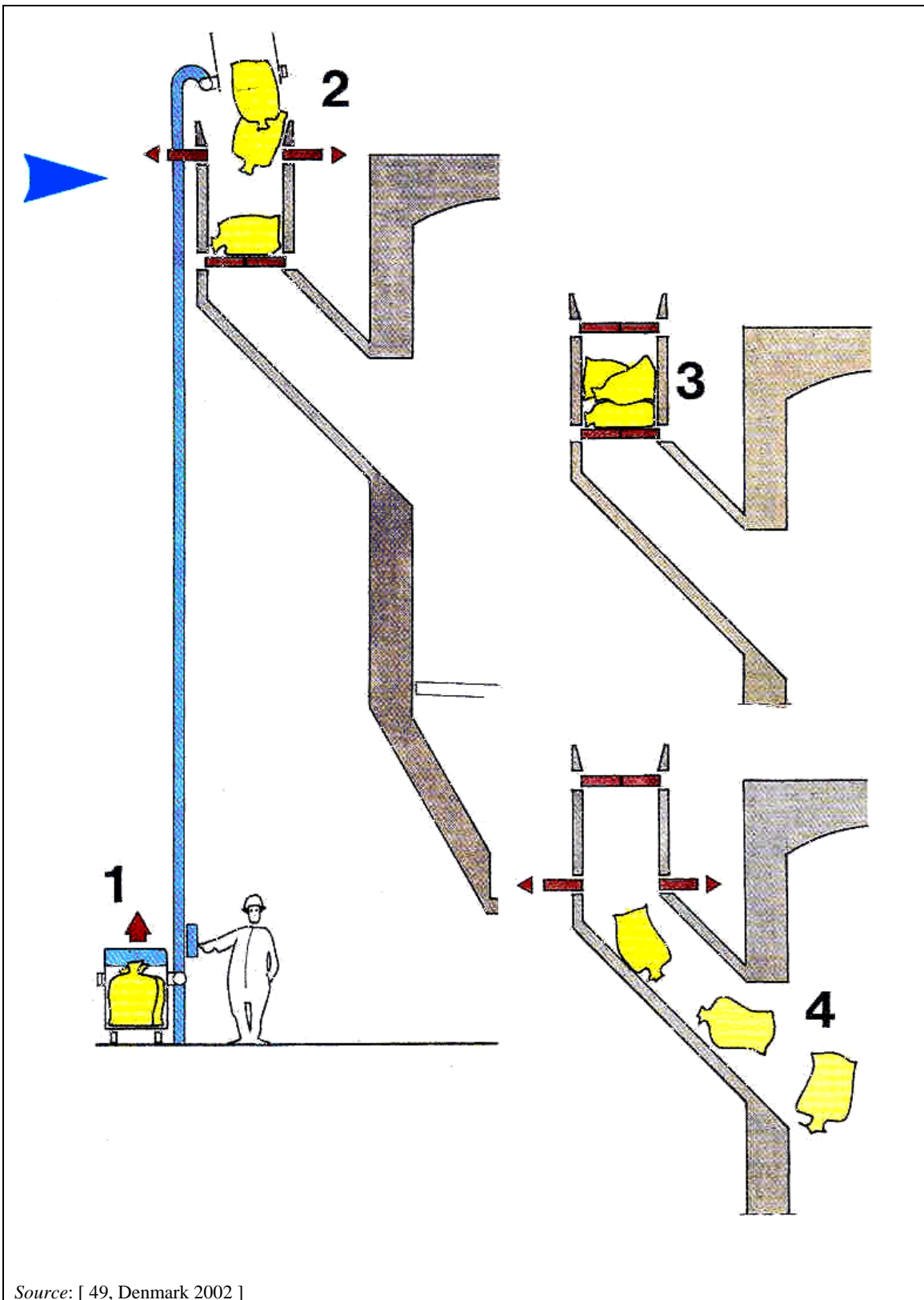

Source: [49, Denmark 2002]

Figure 2.4: Examples of the stages of a clinical waste loading system used at a municipal waste incinerator

2.3.1.2 Incineration grate

The incineration grate accomplishes the following functions:

- transport of materials to be incinerated through the furnace;
- stoking and loosening of the materials to be incinerated;
- positioning of the main incineration zone in the incineration chamber, possibly in combination with furnace performance control measures.

A target of the incineration grate is a good distribution of the incineration air into the furnace, according to combustion requirements. A primary air blower forces incineration air through small grate layer openings into the fuel layer. More air is generally added above the waste bed to complete combustion.

It is common for some fine material (sometimes called riddlings or siftings) to fall through the grate. This material is recovered in the bottom ash remover or recovered separately. It can be recycled to the grate for repeated incineration or removed directly for disposal. When the siftings are recirculated in the hopper, care should be taken not to ignite the waste in the hopper. [74, TWG 2004]

The residence time of the wastes on the grates is usually not more than 60 minutes. [74, TWG 2004]

In general, one can differentiate between continuous (roller and chain grates) and discontinuous (push grates) feeder principles. Figure 2.5 shows some types of grates.

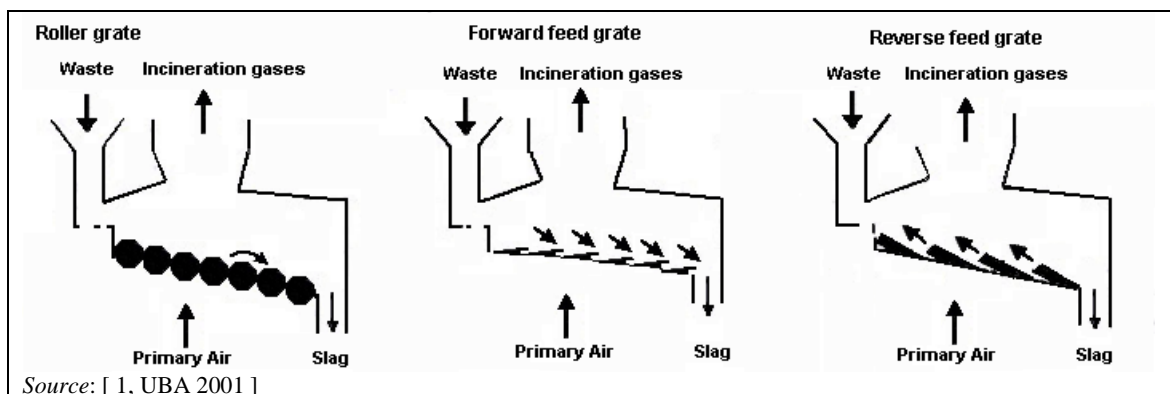

Figure 2.5: Different grate types

Grate cooling is carried out to control metal temperatures and thereby improve grate life. The cooling medium can be air or water (other liquids may also be used, such as oils or other heat-conducting fluid). The flow of the liquid cooling medium is from colder zones to progressively hotter ones in order to maximise the heat transfer. The heat absorbed by the liquid cooling medium may be used in the incineration process or supplied to an external process.

The use of air-cooled grates in Europe is very common, with approximately 90 % of incinerated MSW being treated in plants using air-cooled grates. Air is supplied below the grate and passes through the grate spacings. The main function of this air is to provide the necessary oxygen for oxidation, and the flow rate is designed according to this requirement. Simultaneously, this air cools the grates. When more excess air is introduced, additional cooling is supplied but a larger amount of flue-gas is produced.

Water cooling is most often applied where the calorific value of the waste is higher, e.g. > 12–15 MJ/kg for MSW. The design of the water-cooled system is more complex than air-cooled systems.

The addition of water cooling may allow the grate metal temperature and local combustion temperature to be controlled with greater independence from the primary air supply (normally between the grate bars). This may then allow the temperature and air (oxygen) supply to be optimised to suit specific on-grate combustion requirements and thereby improve the combustion performance. The temperature of the liquid can be used to monitor the reactions (some are endothermic, some exothermic, and to differing degrees) occurring in the waste bed above the grate. These reactions can then be controlled by varying the amount of air supplied through that section of the grate to the waste above. This separation of the cooling and air supply functions increases the control of the process. Greater control of the grate temperature can allow the incineration of higher calorific value wastes without the normally increased operational and maintenance problems.

Different grate systems can be distinguished by the way the waste is conveyed through the different zones in the combustion chamber. Each has to fulfil requirements regarding primary air feeding, conveying velocity and raking, as well as mixing of the waste. Other features may include additional controls, or a more robust construction to withstand the severe conditions in the combustion chamber.

2.3.1.2.1 Rocking grates

[4, IAWG 1997] The grate sections are placed across the width of the furnace. Alternate rows are mechanically pivoted or rocked to produce an upward and forward motion, advancing and agitating the waste.

2.3.1.2.2 Reciprocating grates

This design consists of sections that span the width of the furnace but are stacked above each other. Alternate grate sections slide back and forth, while the adjacent sections remain fixed. Waste tumbles off the fixed portion and is agitated and mixed as it moves along the grate. Numerous variations of this type of grate exist, some with alternating fixed and moving sections, others with combinations of several moving sections to each fixed section. In the latter case, the sections can either move together or at different times in the cycle.

There are essentially two main reciprocating grate variations:

1. Reverse reciprocating grate

The grate bars oscillate back and forth in the reverse direction to the flow of the waste. The grate is sloped from the feed end to the ash discharge end and is comprised of fixed and moving grate steps.

2. Push forward grate

The grate bars form a series of many steps that oscillate horizontally and push the waste in the direction of the ash discharge.

2.3.1.2.3 Travelling grates

This type of grate consists of a continuous metal belt conveyor or interlocking linkages that move along the length of the furnace. The reduced potential to agitate the waste (it is only mixed when it transfers from one belt to another) means that it is seldom used in modern facilities. [4, IAWG 1997]

2.3.1.2.4 Roller grates

This design consists of a perforated roller that traverses the width of the grate area. Several rollers are installed in series and a stirring action occurs at the point where the material tumbles off the rollers. [4, IAWG 1997]

2.3.1.3 Bottom ash discharger

The bottom ash discharger is used to cool and discharge the solid residue (bottom ash) that accumulates at the end of the grate. It also serves as an air seal for the furnace, preventing flue-gas emissions and uncontrolled air ingress to the furnace.

Water-filled ram-type constructions and belt conveyors are commonly used to extract the bottom ash as well as any bulky objects.

The water used for cooling is separated from the bottom ash at the exit and may be recirculated to the ash discharger. A water top-up feed is usually required to maintain an adequate water level in the discharger. The top-up water replaces water lost with the removed bottom ash and evaporation losses. In addition, a water drain may be needed to prevent the build-up of salts – such bleed systems can help to reduce the salt content of the residues if the flow rates are adjusted specifically for this purpose. The bottom ash removal shaft is usually fireproof and is constructed in such a way that bottom ash caking is avoided.

The bottom ash can be discharged dry by operating a ram-type discharger without water. In this case, air sealing of the furnace is achieved by piling up the bottom ash in the inlet section. The bottom ash is cooled down by the air without increasing the surface temperature of the discharger. [82, Germany 2014]

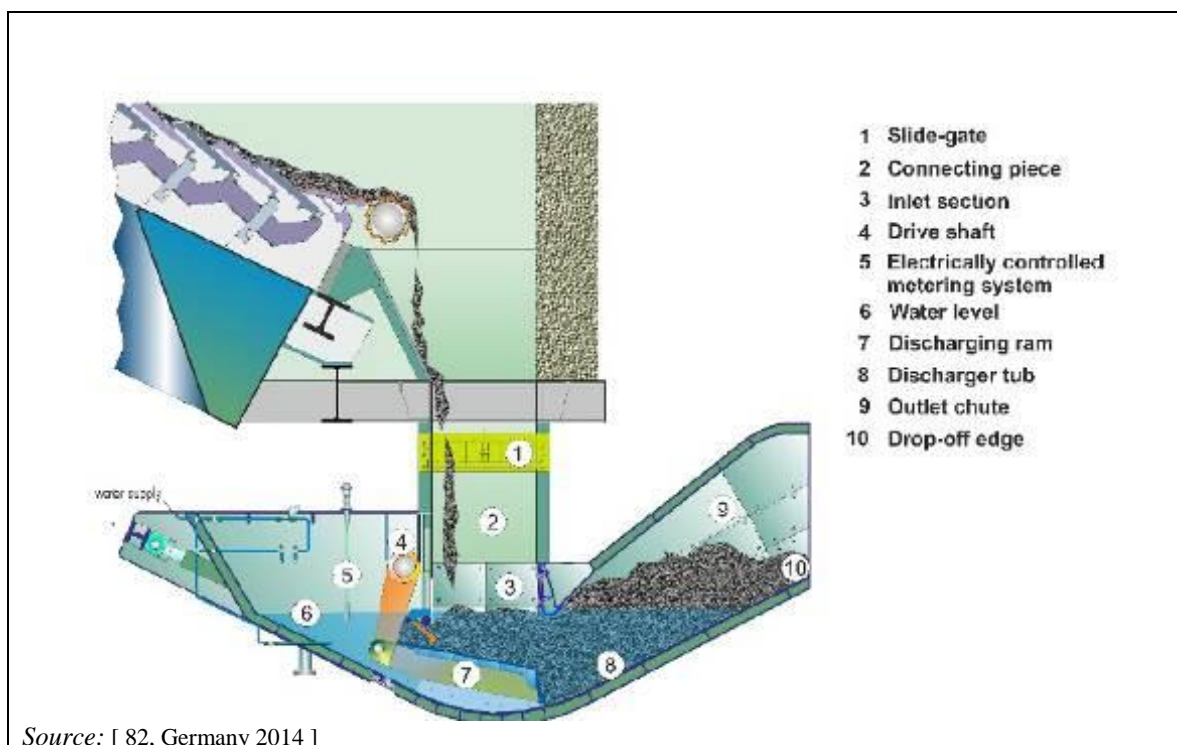

Figure 2.6: Example of a ram-type bottom ash discharger used at a grate incinerator

2.3.1.4 Incineration chamber and boiler

The incineration chamber (see Figure 2.7) typically consists of a grate situated at the bottom, cooled and non-cooled walls on the furnace sides, and a ceiling or boiler surface heater at the top. Municipal waste generally has a high volatile content, so the volatile gases are driven off and burn above the grate with only a small part of the actual incineration taking place on or near the grate.

The following requirements influence the design of the incineration chamber:

- shape and size of the incineration grate - the size of the grate determines the size of the cross-section of the incineration chamber; vortexing and homogeneity of flue-gas flow - complete mixing of the flue-gases is essential for good flue-gas incineration;
- sufficient residence time for the flue-gases in the hot furnace - sufficient reaction time at high temperatures is needed to ensure complete incineration;
- partial cooling of flue-gases by the injection of secondary air - in order to avoid the melting of hot fly ash in the boiler, the flue-gas temperature must not exceed an upper limit at the incineration chamber exit.

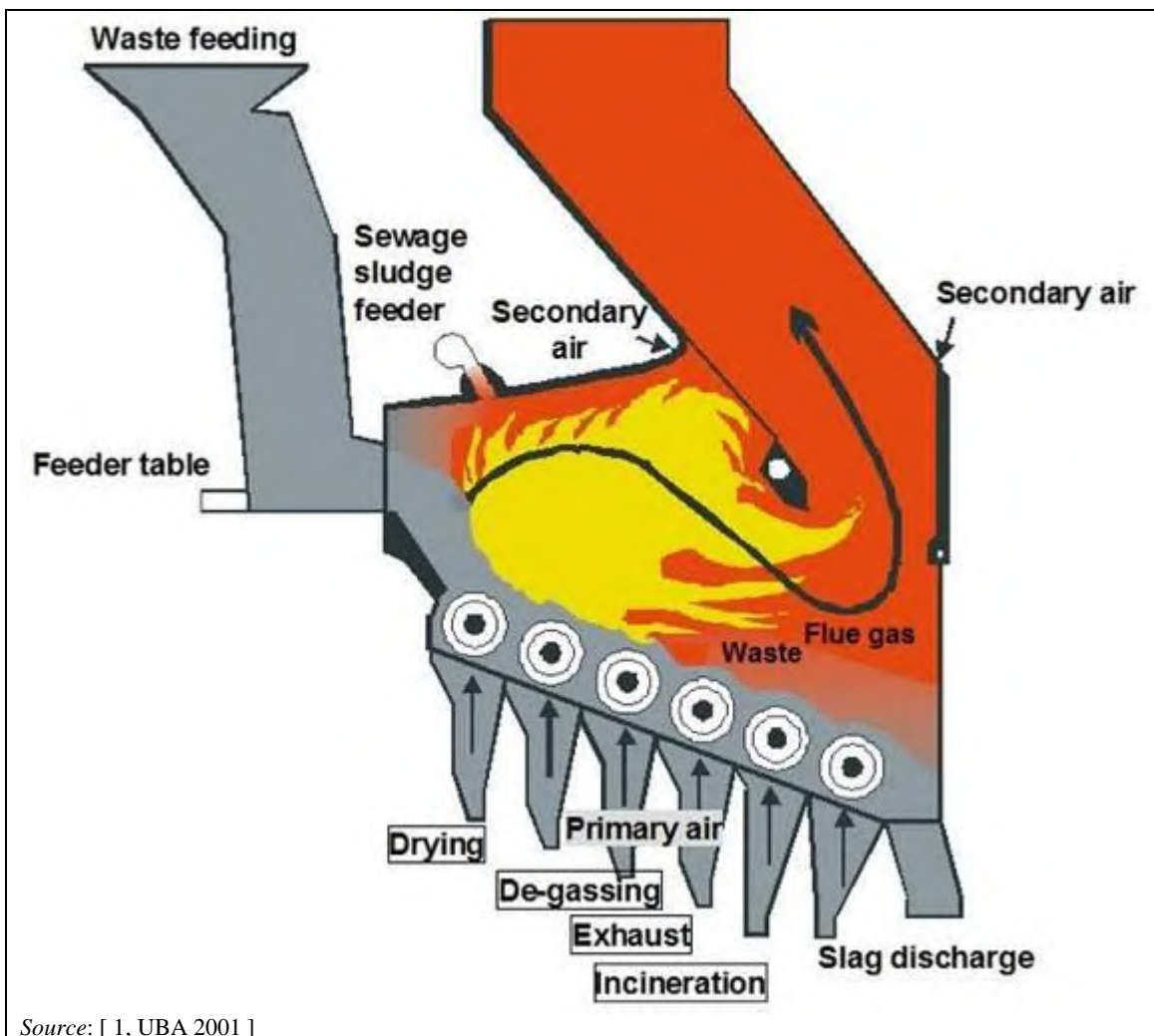

Source: [1, UBA 2001]

Figure 2.7: Example of an incineration chamber

The detailed design of a combustion chamber is usually linked to the grate type. Its precise design demands certain compromises as the process requirements change with the fuel characteristics.

A design that is not appropriate would lead to poor retention of combustible gases in the combustion zones, poor gas phase burnout and higher emissions.

In general, three different designs can be distinguished. The nomenclature comes from the flow direction of the flue-gases in relation to the waste flow: unidirectional current; countercurrent and medium current (see Figure 2.8).

Unidirectional current, co-current, or parallel flow furnace

In a co-current combustion arrangement, primary combustion air and waste are guided in a co-current flow through the combustion chamber. Accordingly, the flue-gas outlet is located at the end of the grate. Only a comparatively low amount of energy is exchanged between the combustion gases and the waste on the grate.

The advantage of unidirectional current concepts is that the flue-gas has the longest residence time in the ignition area and that it passes through the maximum temperature zone. To facilitate ignition, the primary air is preheated.

Counter-flow or countercurrent furnace

In this case, primary combustion air and waste are guided in a countercurrent flow arrangement through the combustion chamber and the flue-gas outlet is located at the front end of the grate. The hot flue-gases facilitate the drying and ignition of the waste.

Special attention must be paid to avoid the passage of unburned gas streams. As a rule, counter-flow current concepts require higher secondary or upper air additions.

Medium current or centre-flow furnace

The composition of municipal solid waste varies considerably and the medium current concept is a compromise for a wide feed value spectrum. A good mixture of all partial flue-gas currents must be considered through mixture-promoting contours and/or secondary air injections. In this case, the flue-gas outlet is located in the middle of the grate.

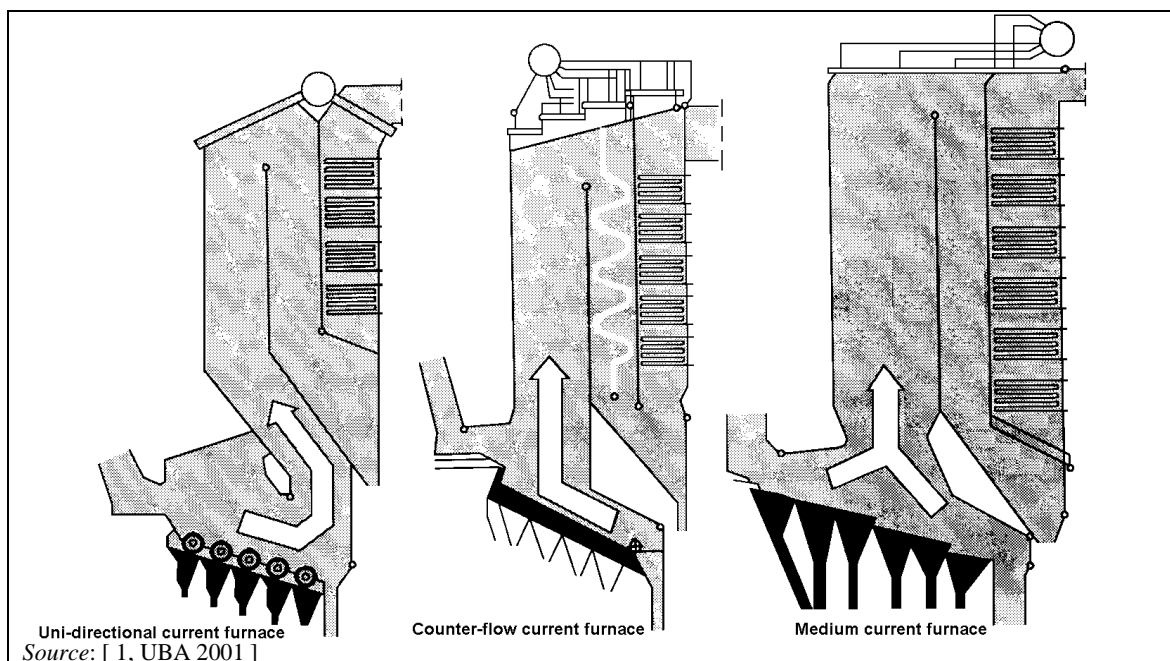

Figure 2.8: Various furnace designs with differing direction of the flue-gas and the waste flow

Table 2.6 compares different types of incineration chamber designs in terms of their geometric characteristics, suitability to different waste types, and additional considerations regarding specific air supply requirements for example.

Table 2.6: A comparison of the features of some different incineration chamber designs

Type	Design features	Comments
Co-current or parallel flow	<ul style="list-style-type: none"> Exit to combustion chamber at end of furnace Gas flow in same direction as waste movement 	<ul style="list-style-type: none"> Suited to higher LHV wastes All evolved gases must pass through maximum temperature zone and have long retention time Primary air heating required in ignition zone
Countercurrent or counter-flow	<ul style="list-style-type: none"> Exit to combustion chamber at start of furnace Gas flow in opposite direction to the waste 	<ul style="list-style-type: none"> Suited to low-LHV / high-moisture / high-ash waste (as hot gases from volatilisation zone pass over the drying zone) Higher secondary air requirements to ensure gas burnout
Medium current or centre-flow	<ul style="list-style-type: none"> Exit to combustion chamber in middle of furnace 	<ul style="list-style-type: none"> Compromise of the above for wide spectrum of waste Furnace configuration / secondary air important to ensure gas burnout
Split-flow	<ul style="list-style-type: none"> Exit from combustion chamber in middle position but split by central section 	<ul style="list-style-type: none"> Central section aids retention of gases and allows secondary air to be injected from additional locations Mainly used for very large furnaces
Source: [1, UBA 2001], [2, InfoMil 2002], [4, IAWG 1997], [15, Segers 2002]		

Split-flow systems are mainly applied to larger furnaces because of the additional secondary air mixing they allow in central positions of the furnace. In smaller furnaces, adequate mixing may be achieved using side wall injection of the secondary air.

A balanced combustion chamber design ensures that gases evolved from the waste are well mixed and retained at a sufficient temperature in the combustion chamber to allow the combustion process to be fully completed. This principle is applicable to all incineration processes.

2.3.1.5 Incineration air feeding

The incineration air fulfils the following objectives:

- provision of oxidant;
- cooling;
- avoidance of slag formation in the furnace;
- mixing of flue-gas.

Air is added at various places in the combustion chamber. It is usually described as primary or secondary, although tertiary air and recirculated flue-gases are also used.

The primary air is generally taken from the waste bunker. This maintains a slight negative pressure in the bunker hall and eliminates most odour and dust emissions from the bunker area. Primary air is blown by fans into the areas below the grate, where its distribution can be closely controlled using multiple wind boxes, and distribution valves.

The air can be preheated to pre-dry the waste when its calorific value is low. The primary air is blown through the grate layer into the fuel bed. It cools the grate bar and carries oxygen into the incineration bed.

Secondary air is blown into the incineration chamber at high speeds via, for example, injection lances or from internal structures. This is carried out to ensure complete incineration and is responsible for the intensive mixing of flue-gases and prevention of the free passage of unburned gas streams.

2.3.1.6 Incineration temperature, residence time and oxygen content

Incinerators are designed and operated to achieve a good burnout of the combustion gases by ensuring that the combustion gases are maintained at a minimum temperature for a minimum residence time at a minimum oxygen level. Typical values are a minimum temperature of 850 °C to 1 100 °C (with higher temperatures usually associated with certain hazardous wastes) for at least 2 seconds at an oxygen level of at least 6 %.

The carbon monoxide content of the flue-gas is a key indicator of the quality of combustion.

2.3.1.7 Auxiliary burners

At start-up, auxiliary burners are used to heat up the furnace to a specified temperature before any waste is added. During operation, the burners are switched on automatically if the temperature falls below the specified value. During shutdown, the burners are used until there is no more unburnt waste in the furnace to keep the furnace temperature at the desired level.

[74, TWG 2004]

2.3.2 Rotary kilns

Rotary kilns are very robust and almost any waste, regardless of type and composition, can be incinerated. Rotary kilns are, in particular, very widely applied for the incineration of hazardous wastes and most hazardous clinical waste is incinerated in high-temperature rotary kiln incinerators. [64, TWG 2003]

Operating temperatures of rotary kilns range from around 500 °C (as a gasifier) to 1 450 °C (as a high-temperature ash melting kiln). Higher temperatures are sometimes encountered, but usually in non-waste incineration applications. When used for conventional oxidative combustion, the kiln temperature is generally above 850 °C. Kiln temperatures in the range of 900–1 200 °C are typical when incinerating hazardous wastes.

Generally, and depending on the waste input, the higher the operating temperature, the greater the risk of fouling and thermal stress damage to the refractory kiln lining. Some kilns have a cooling jacket (using air or water) that helps to extend refractory life, and therefore the time between maintenance shutdowns.

Water cooling is usually used together with higher temperatures in the kiln. The rotary kiln water cooling system consists of two cooling circuits. The primary cooling water circuit delivers primary cooling water on top of the rotary kiln and distributes it evenly to guarantee an equal cooling effect over the whole shell of the kiln. Water is then collected in water collection basins located under the kiln, from where it flows into the water collection tank. Water is circulated back through a filter and a heat exchanger with a circulation pump. Evaporation is compensated with additional make-up water, which is automatically buffered with NaOH in order to avoid corrosion.

The secondary circuit removes heat from the primary circuit through heat exchangers and transfers it for use.

The system delivers cooling water through hundreds of spray nozzles situated all over the shell of the kiln, keeping the temperature of the shell at 80–100 °C, whereas for air cooling the steel shell temperature is typically a few hundred degrees higher. The rotary kiln cooling increases the heat transfer through the refractory enough to reduce the rate of chemical erosion to a minimum.

The heat transfer through the furnace into the cooling water varies between 0.5 MW and 3.0 MW, depending on the size of the rotary kiln and the thickness of the refractory. The thickness of the refractory includes the remaining brick lining and the solidified bottom ash layer.

A schematic drawing of a rotary kiln incineration system is shown below.

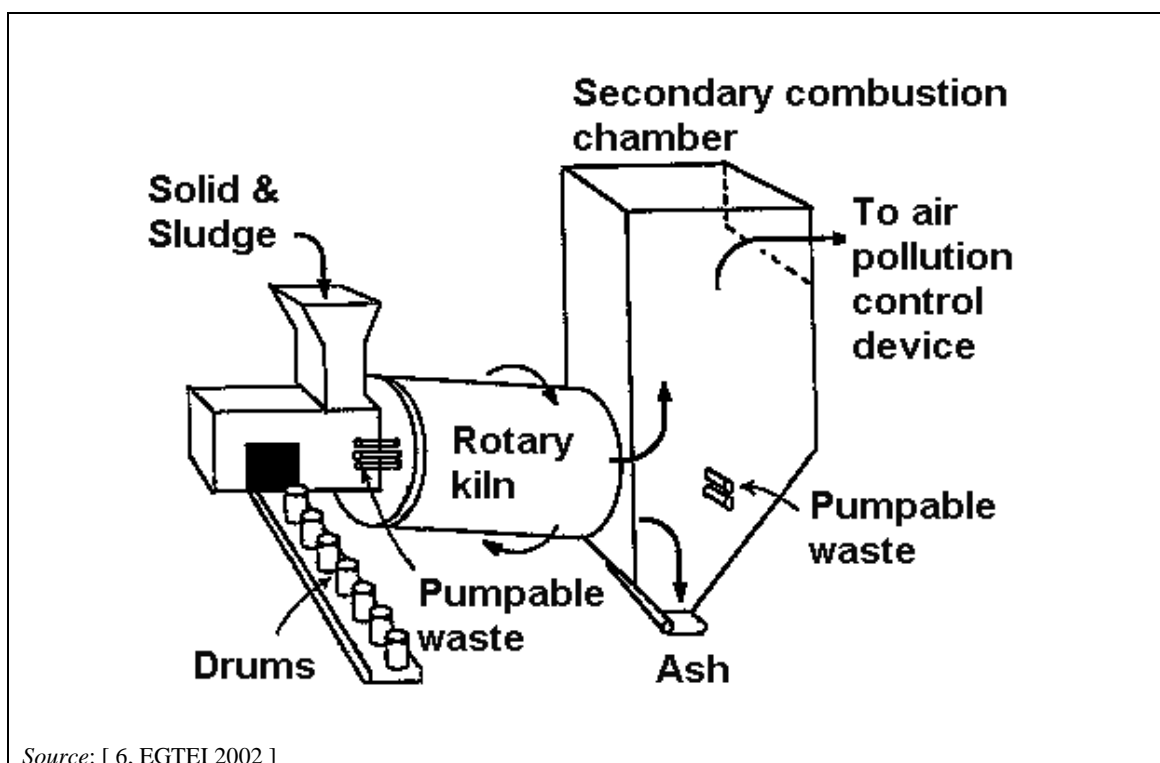

Figure 2.9: Schematic of a rotary kiln incineration system

The rotary kiln consists of a cylindrical vessel slightly inclined on its horizontal axis. The vessel is usually located on rollers, allowing the kiln to rotate or oscillate around its axis (reciprocating motion). The waste is conveyed through the kiln by gravity as it rotates. Direct injection is used particularly for liquid, gaseous or pasty (pumpable) wastes – especially where they present safety risks and require particular care to reduce operator exposure.

The residence time of the solid material in the kiln is determined by the horizontal angle of the vessel and the rotation speed: a residence time of between 30 and 90 minutes is normally sufficient to achieve good waste burnout.

Solid waste, liquid waste, gaseous waste, and sludges can all be incinerated in rotary kilns. Solid materials are usually fed through a non-rotating hopper; liquid waste may be injected into the kiln through burner nozzles; pumpable waste and sludges may be injected into the kiln via a water-cooled tube.

In order to increase the destruction of toxic compounds, a post-combustion chamber is usually used. Additional firing using liquid waste or support fuel may be carried out to maintain the temperatures required to ensure the complete destruction of compounds in the exhaust gas.

2.3.2.1 Rotary kiln with post-combustion chamber for hazardous waste incineration

For the incineration of hazardous waste, a combination of rotary kilns and post-combustion chambers has proven successful, as this combination can treat solid, pasty, liquid and gaseous wastes uniformly (see Figure 2.10).

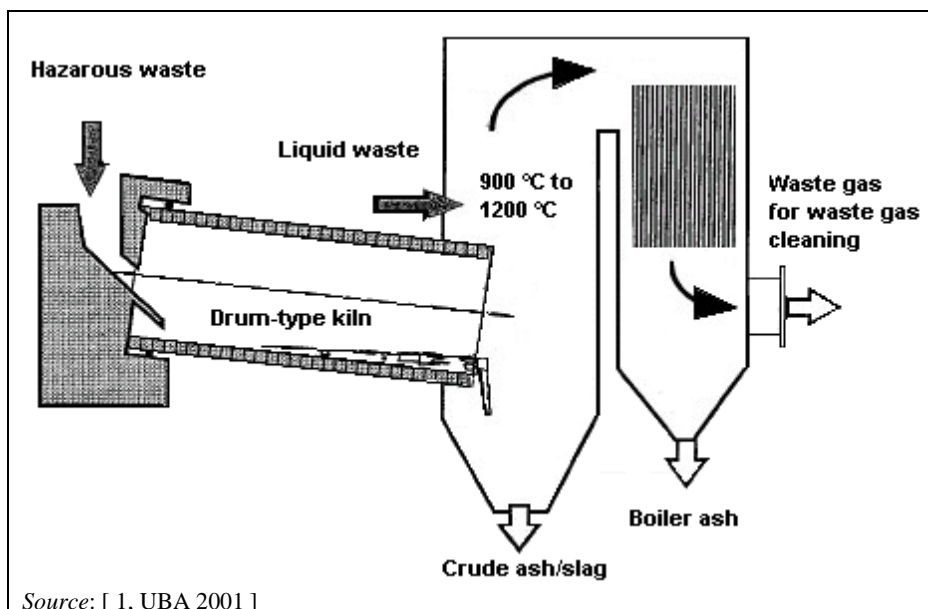

Figure 2.10: Rotary (drum-type) kiln with post-combustion chamber

Rotary kilns between 10 metres and 15 metres in length, with a length to diameter ratio usually in the range of 3 to 6, and with an inner diameter between 1 metre and 5 metres are usually deployed for hazardous waste incineration.

Some rotary kilns have throughputs of up to 140 000 tonnes/yr each. Where heat recovery is carried out, steam generation is directly correlated with the average heat value of the waste. Rotary kilns are highly flexible in terms of waste inputs and typical operating ranges are:

- solid wastes: 10–70 %;
- liquid wastes: 25–70 %;
- pasty wastes: 5–30 %;
- barrels: up to 15 %.

The kiln operating temperature is usually between 850 °C and 1 300 °C. The temperature may be maintained by burning higher calorific (e.g. liquid) waste, waste oils, heating oil or gas. Higher temperature kilns may be fitted with water-based kiln cooling systems. Operation at higher temperatures may result in molten (vitrified) bottom ash (slag), whilst at lower temperatures the bottom ashes are sintered.

To protect rotary kilns from temperatures of up to 1 200 °C, they are lined with refractory bricks that have a high content of Al_2O_3 and SiO_2 . The decision regarding the selection of bricks appropriate for each application is a function of the waste composition. The bricks can be attacked by alkaline metal compounds (formation of low-melting eutectic alloys), as well as by HF (formation of SiF_4). To protect refractory bricks from chemical attack and from the mechanical impact of falling barrels, a hardened slag layer will usually be formed at the beginning of the operation by feeding wastes with good slag-forming properties or mixtures of glass and/or sand. Later on, the kiln is usually managed so as to maintain this slag layer, by controlling the temperature, the mineral content of the wastes and sometimes using additives such as sand. [74, TWG 2004]

There have been tests with other surface types but neither injected nor stamped refractory masses have proved successful. The surfacing of rotary kilns with special alloyed steels has only been successful in some special applications. The durability of the fireproof surface remains dependent upon the waste input. A service life of between 4 000 hours and 16 000 hours is normal.

Rotary kilns are tilted towards the post-combustion chamber. This, along with the slow rotation (approximately 3–40 rotations per hour), facilitates the transport of solid hazardous wastes that are fed into the upper end, as well as the bottom ash produced during incineration, in the direction of the post-combustion chamber. These are then removed together with the ash from the post-combustion chamber via a wet bottom ash discharger. The residence time for solid wastes is typically greater than 30 minutes.

The post-combustion chamber provides for the necessary residence time for the incineration of the flue-gases produced in the kiln, as well as for the incineration of directly injected liquid and gaseous wastes. The size of the post-combustion chamber and gas flows predict the actual residence times achieved. Reducing residence times can increase the risk of incomplete gas burnout.

The temperatures in the post-combustion chamber typically vary between 900 °C and 1 200 °C depending on the installation and the waste feed. Most installations have the ability to inject secondary air into the post-combustion chamber. Due to the high temperatures and the secondary air introduction, the combustion of the exhaust gases is completed and organic compounds (e.g. low molecular weight hydrocarbons, PAHs, PCBs and dioxins) are destroyed.

A rotary kiln incineration plant with an incineration capacity of 45 000 tonnes/yr is shown in Figure 2.11. The plant is divided into three main areas:

- rotary kiln with post-combustion chamber;
- waste heat boiler for steam generation;
- multi-step flue-gas cleaning.

There is, in addition, the infrastructure for waste and fuel storage, the feed system, and the storage, treatment and disposal of the waste and waste waters (from wet gas scrubbing) produced during incineration.

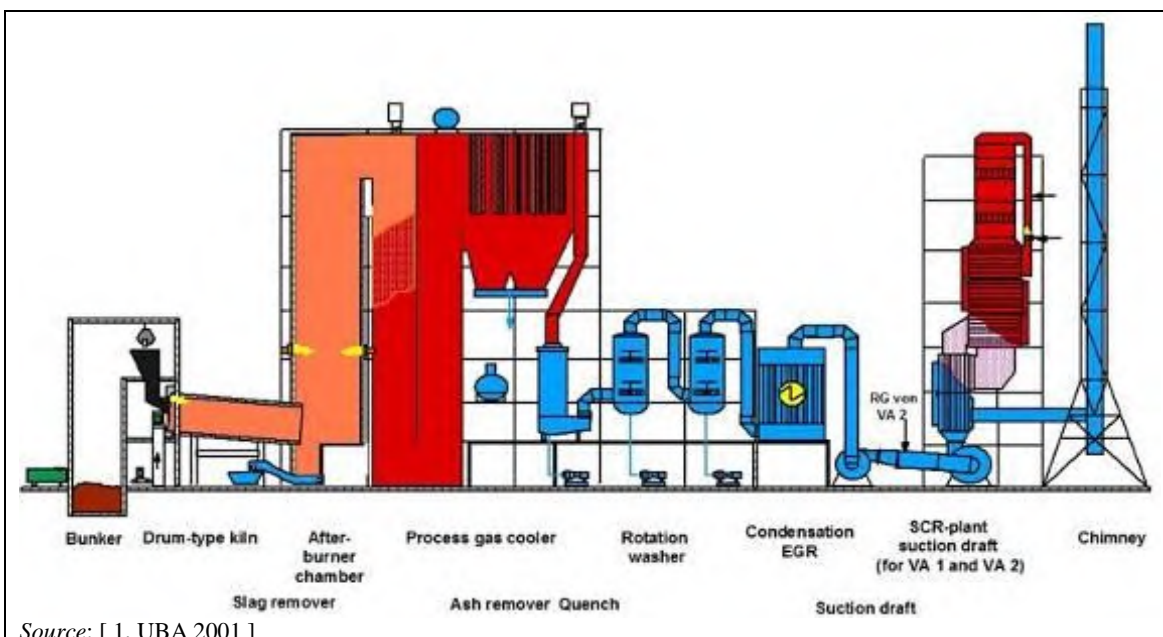

Figure 2.11: Example of a rotary (drum-type) kiln plant for hazardous waste incineration

2.3.3 Fluidised beds

Fluidised bed incinerators are widely applied to the incineration of finely divided wastes, e.g. RDF and sewage sludge. Fluidised beds have been used for decades for the combustion of homogeneous fuels such as coal, raw lignite, sewage sludge, and biomass.

The fluidised bed incinerator is a lined combustion chamber usually in the form of a vertical cylinder. In the lower section, a bed of inert material, (e.g. sand or ash) on a grate or distribution plate is fluidised with preheated combustion air. The waste for incineration is continuously fed into the fluidised sand/ash bed from the top or side via a pump, a star feeder, a screw-tube conveyor, an apron conveyor or a weighting band. [66, UllmansEncyclopaedia 2001], [7, TWG 2017]

In the fluidised bed, drying, volatilisation, ignition and combustion take place. The temperature in the free space above the bed (the freeboard) is generally between 850 °C and 950 °C. Above the fluidised bed material, the freeboard is designed to allow a sufficient residence time of the gases in the combustion zone. In the bed itself, the temperature is lower and may be around 650°C.

Because of the good mixing in the reactor, fluidised bed incineration systems generally have a uniform temperature and oxygen concentration, which results in stable operation. For heterogeneous wastes, fluidised bed combustion requires the selection and pre-treatment of the waste so that it conforms with size specifications. [64, TWG 2003] [74, TWG 2004]

Pre-treatment usually consists of sorting and crushing larger inert particles, and shredding. Removal of ferrous and non-ferrous materials may also be required. The particle size of the waste must be small, often with a maximum diameter of 50 mm. However, it is reported that average acceptable diameters for rotating fluidised beds are 200–300 mm. [74, TWG 2004]

The schematic diagram below shows an installation that pretreats mixed MSW for incineration in a fluidised bed incineration plant. Several pre-treatment stages are shown including mechanical pulverisation and pneumatic separation, along with the final stages of incineration, FGC and residue storage.

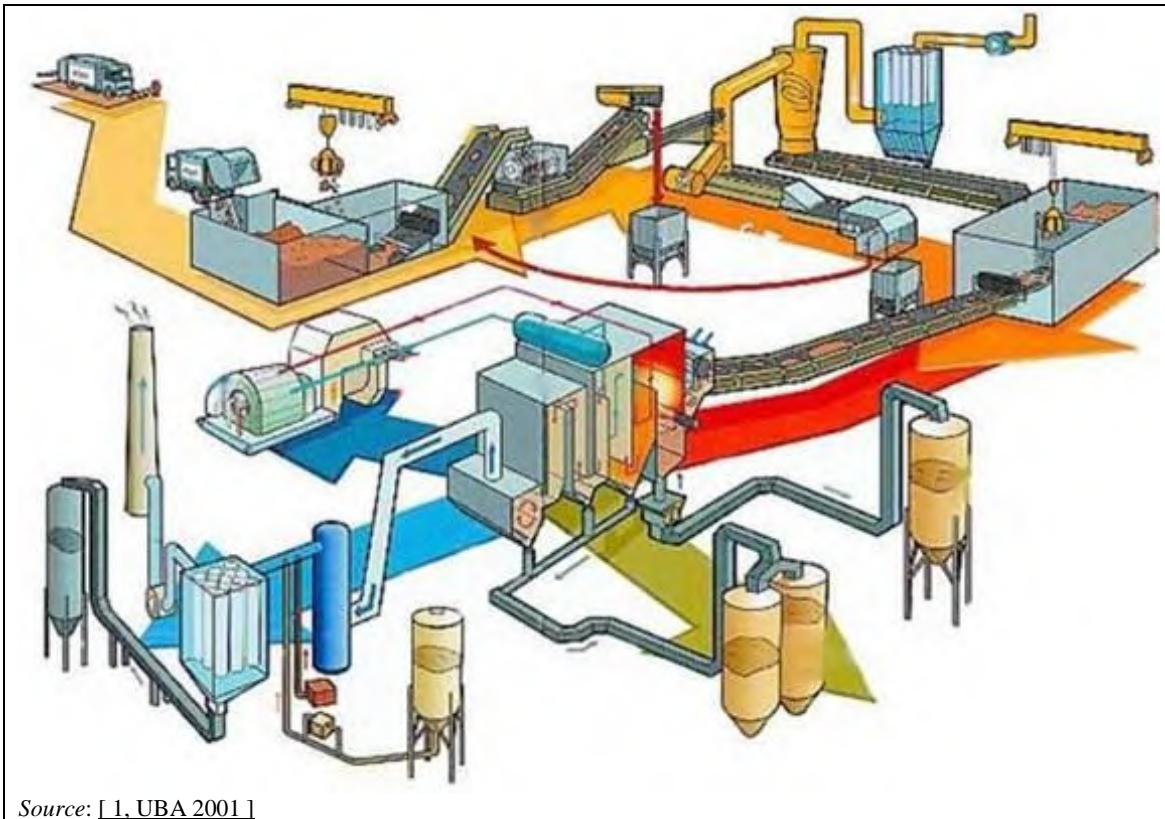

Source: [1, UBA 2001]

Figure 2.12: Schematic diagram showing pre-treatment of MSW prior to fluidised bed combustion

During incineration, the fluidised bed contains the unburnt waste and the ash produced. The ash surplus is usually removed at the bottom of the furnace. [1, UBA 2001] [33, Finland 2002]

The heat produced by the combustion can be recovered by devices either integrated inside the fluidised bed or at the exit of the combustion gases, or by a combination of these designs.

The relatively high cost of pre-treatment processes required for some wastes has restricted the commercial use of these systems to larger scale projects. This has been overcome in some cases by the selective collection of some wastes, and the development of quality standards for refuse-derived fuels (RDF). The combination of a prepared quality-controlled waste and fluidised bed combustion can allow improvements in the control of the combustion process, and the potential for a simplified, and therefore less expensive, flue-gas cleaning stage.

The following table shows the properties of various waste fractions that are treated in fluidised beds.

Table 2.7: Properties of various refuse-derived fuel (RDF) fractions treated in fluidised beds

Parameter	Unit	Commercial waste	Pretreated construction waste	Sorted and pretreated household waste
Net calorific value	MJ/kg	16–20	14–15	13–16
	MWh/t	4.4–5.6	3.8–4.2	3.6–4.4
Moisture	wt-%	10–20	15–25	25–35
Ash	wt-%	5–7	1–5	5–10
Sulphur	wt-%	< 0.1	< 0.1	0.1–0.2
Chlorine	wt-%	< 0.1–0.2	< 0.1	0.3–1.0
Storage properties	wt-%	Good	Good	Good as pellets

Source: [33, Finland 2002]

The following fluidised bed furnace technologies can be differentiated according to the gas speeds and design of the nozzle plate:

- **Stationary (or bubbling) fluidised bed** (atmospheric and pressurised): The inert material is mixed, but the resulting upward movement of solids is not significant (see Figure 2.13).
- **Rotating fluidised bed** is a version of the bubbling fluidised bed: The fluidised bed is rotated which results in a longer residence time in the incineration chamber. Rotating fluidised bed incinerators have been used for mixed municipal waste since the 1990s.
- **Circulating fluidised bed:** The bed material is recirculated by the use of a hot cyclone. The higher gas speeds in the combustion chamber are responsible for the partial removal of the fuel and bed material, which is fed back into the incineration chamber by a recirculation loop (see Figure 2.14).

In order to start up the incineration process, the fluidised bed must be heated to at least the minimum ignition temperature of the waste feedstock (or higher where required by legislation). This may be accomplished by preheating the air with oil or gas burners, which remain operative until incineration can occur independently. The waste falls into the fluidised bed, where it is crushed through abrasion and incineration. Usually, the majority of the ash is transported with the flue-gas flow and requires separation in FGC equipment, although the actual proportion of bottom ash (removed from the base of the bed) and fly ash depends on the fluidised bed technology and the waste itself. [1, UBA 2001]

Fouling problems, common in waste incineration boilers, can be managed by controlling the waste quality (mostly keeping chlorine, potassium, sodium and aluminium low) and by boiler and furnace design. Fluidised bed furnaces enable the use of some boiler designs not applicable to grate furnaces because of the more stable temperatures and the presence of the bed material.

2.3.3.1 Stationary (or bubbling) fluidised bed incineration for sewage sludge

The stationary or bubbling fluidised bed (BFB) is commonly used for sewage sludge, and other industrial sludges, e.g. petrochemical and chemical industry sludges. It consists of a cylindrical or rectangular lined incineration chamber, a nozzle bed, and a start-up burner located below (see Figure 2.13).

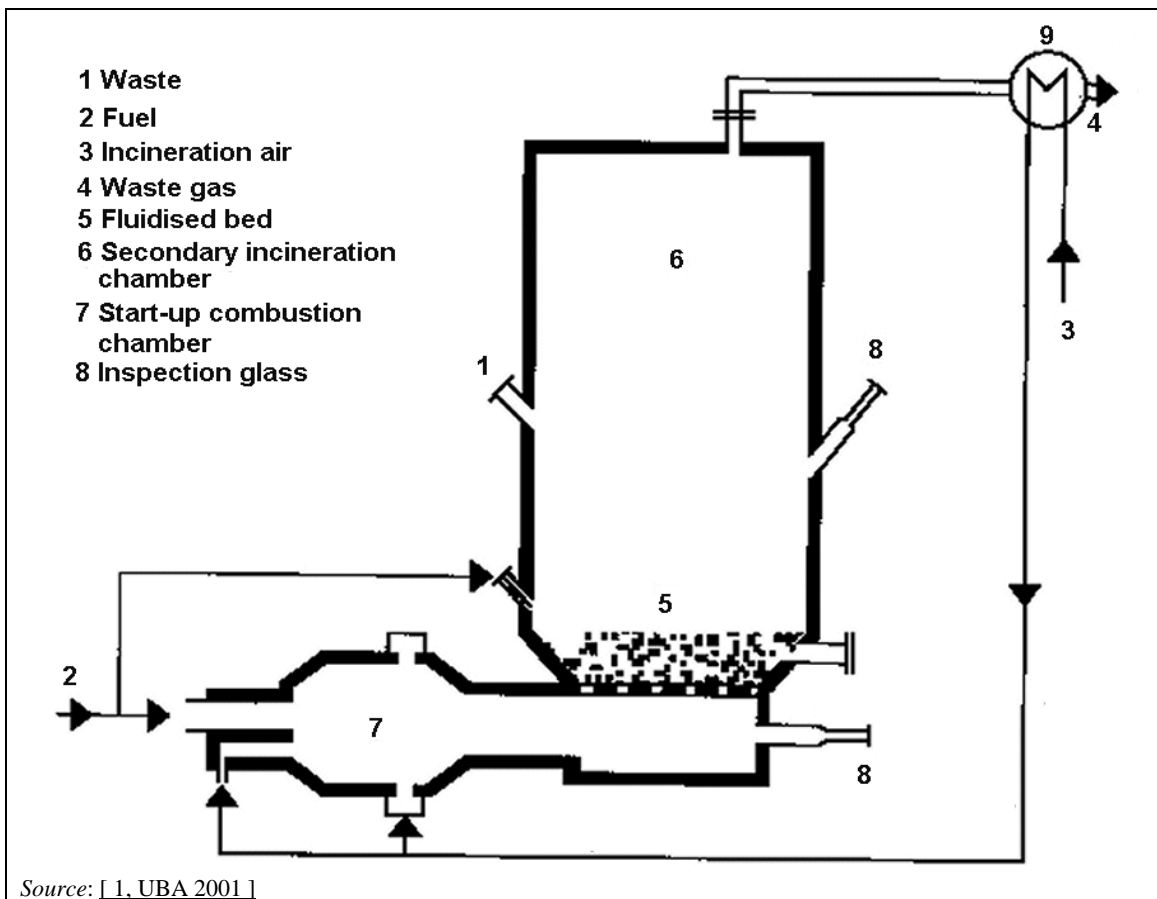

Figure 2.13: Main components of a stationary/bubbling fluidised bed

Preheated air flows up through a distribution plate and fluidises the bed material. Depending on the application, various bed materials (silica sand, basalt, mullite, etc.) and bed material particle sizes (approximately 0.5–3 mm) can be used.

[2, InfoMil 2002], [64, TWG 2003]

The waste can be loaded via the head, on the sides with belt-charging machines, or directly injected into the fluidised bed. In the bed, the waste is crushed and mixed with hot bed material, dried and partially incinerated. The remaining fractions (volatile and fine particles) are incinerated above the fluidised bed in the freeboard. The remaining ash is removed with the flue-gas at the head of the furnace.

Drainage and drying pre-treatment stages can be used so that the waste burns without the need for additional fuels. Recovered heat from the incineration process may be used to provide the energy for waste drying.

At start-up or when the sludge quality is low (e.g. with old sludge or a high share of secondary sludge), additional fuel (oil, gas and/or waste fuel) can be used to reach the prescribed furnace temperature (typically 850 °C). Water can be injected into the furnace to control the temperature.

The furnace must be preheated to its operating temperature before waste feeding starts. For this purpose, a start-up incineration chamber (see Figure 2.13) may be located below the nozzle bed. This has an advantage over an overhead burner, as the heat is introduced directly into the fluidised bed. Additional preheating may be provided by fuel lances that protrude over the nozzle bed into the sand bed.

The size of the furnace is largely determined by the required evaporation (furnace cross-section), the heat turnover in the furnace (furnace volume) and the required amount of air.

Example operational parameters for a fluidised bed sewage sludge incinerator are shown in Table 2.8.

Table 2.8: Main operational criteria for stationary fluidised beds

Parameter	Unit	Value
Steam load	kg/m ² h	300–600
Feed air amount	Nm ³ /m ² h	1 000–1 600
Heat turnover	GJ/m ³ h	3–5
Final incineration temperature	°C	850–950
Residence time, open space and afterburner zone	s	min. 2
Preheating of atmospheric oxygen	°C	400–600
<i>Source: [1, UBA 2001]</i>		

The preheating of air can be eliminated completely with higher calorific fuels (e.g. dried sewage sludge, wood, animal by-products). The heat can be removed via membrane walls and/or immersed heat-exchange systems.

Some processes incorporate drying as a first step. Steam for the drying may be produced by a boiler and then used as the heating medium with no direct contact between the steam and the sludge. Sludge vapours can be extracted from the dryer and condensed. The condensed water typically has a high COD (approximately 2 000 mg/l) and N content (approximately 600–2 000 mg/l) and may contain other pollutants (e.g. heavy metals) from the sewage sludge, and therefore will often require treatment before final discharge. The remaining non-condensates may be incinerated. After incineration, the flue-gases can be cooled in a heat exchanger in order to preheat the incineration air to temperatures of approximately 300 °C and in some cases over 500 °C. The remaining heat in the steam boiler can be recovered and used for the production of saturated steam (pressure level approximately 10 bar), which in turn can be used for the partial pre-drying of sludge. [64, TWG 2003]

In addition to sewage sludge, other wastes from the waste water treatment process are often incinerated, e.g. swim scum, screenings, and extracted fats.

Plants receiving partially dried sludge require less additional fuels than plants receiving raw sludges. The heat values of the sludge for auto-thermal incineration lie between 3.5 MJ/kg and 6.5 MJ/kg. Values between 2.2 MJ/kg and 4.8 MJ/kg sludge are seen where raw sewage is treated. Approximately 3.5 MJ/kg sludge is considered the limit for auto-thermal incineration. The need for additional fuel can be reduced by the use of efficient internal energy recovery systems, e.g. recovery of heat from flue-gases to heat incineration air and/or use of heat for sludge drying.

Heating oils and natural gas are the most commonly used additional fuels in dedicated sewage sludge incinerators. Selected liquid and solid wastes, as well as biogas when anaerobic digestion is carried out nearby, are also used.

2.3.3.2 Circulating fluidised bed (CFB) for sewage sludge

The circulating fluidised bed (CFB, see Figure 2.14 below) is especially appropriate for the incineration of dried sewage sludge with a high calorific value and of pretreated municipal solid waste. It works with fine bed material and at high gas speeds that remove most of the solid material particles from the fluidised bed chamber with the flue-gas. The particles are then separated in a downstream cyclone and returned to the incineration chamber.

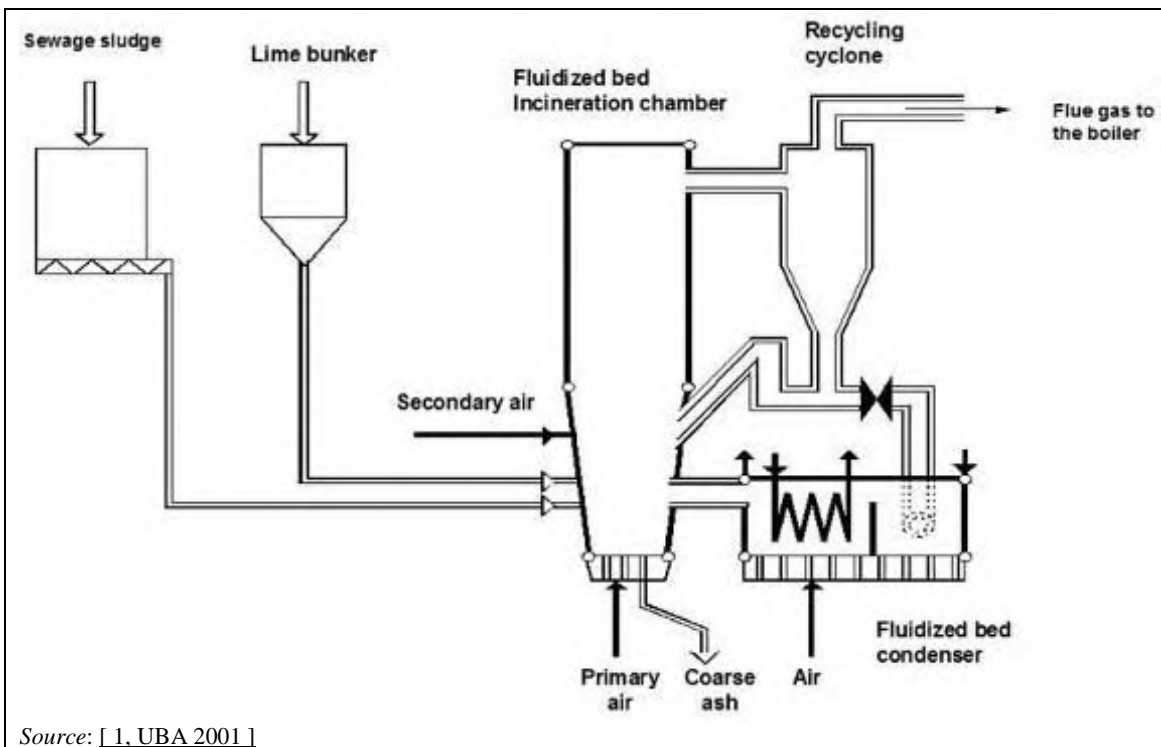

Figure 2.14: Main components of a circulating fluidised bed

The advantage of this process is that a high heat turnover and a more uniform temperature along the height can be reached with a low reaction volume. The plant size is generally larger than for a BFB and a wider range of waste inputs can be treated. The waste is injected at the side into the incineration chamber and is incinerated at 850–950 °C. The surplus heat is removed through membrane walls and via heat exchangers placed between the recycling cyclones and the CFB, which cool the returned ash as a way to control the heat removal.

2.3.3.3 Spreader-stoker furnace

This system can be considered an intermediate system between grate and fluidised bed incineration.

The waste (e.g. RDF, sludge) is blown into the furnace pneumatically at a height of several metres. Fine particles participate directly in the incineration process, while the larger particles fall on the travelling grate, which is moving in the opposite direction to the waste injection. As the largest particles are spread over the greatest distance, they spend the longest time on the grate in order to complete the incineration process. Secondary air is injected to ensure that the flue-gases are adequately mixed in the incineration zone.

Compared to grate incineration, the grate construction is less complicated due to the relatively smaller thermal and mechanical load. When compared to fluidised bed systems, the uniformity of particle size is less important and there is a lower risk of clogging.

[64, TWG 2003]

2.3.3.4 Rotating fluidised bed

This system is a development of the bubbling bed for waste incineration. Inclined nozzle plates, wide bed ash extraction chutes and upsized feeding and extraction screws are specific features to ensure reliable handling of solid waste. Temperature control within the refractory-lined combustion chamber (bed and freeboard) is by flue-gas recirculation. This allows the incineration of fuels with a wide range of calorific values, e.g. co-combustion of sludges and pretreated wastes. [74, TWG 2004]

2.3.4 Pyrolysis and gasification systems

2.3.4.1 Introduction to gasification and pyrolysis

[9, VDI 2002] Alternative technologies for thermal waste treatment have been applied to selected waste streams and on a much smaller scale than conventional, combustion-based incineration.

These technologies attempt to separate the components of the reactions that occur in conventional waste incineration plants by controlling process temperatures and pressures in specially designed reactors (see Table 2.9).

Table 2.9: Typical reaction conditions and products of combustion, pyrolysis and gasification processes

	Combustion	Pyrolysis	Gasification
Reaction temperature (°C)	800–1 450	250–700	500–1 600
Pressure (bar)	1	1	1–45
Atmosphere	Air	Inert/Nitrogen	Gasification agent: O ₂ , H ₂ O
Stoichiometric ratio	> 1	0	< 1
Products from the process in the			
• gas phase:	CO ₂ , H ₂ O, O ₂ , N ₂	H ₂ , CO, hydrocarbons, H ₂ O, N ₂	H ₂ , CO, CO ₂ , CH ₄ , H ₂ O, N ₂
• solid phase:	Ash, slag	Ash, coke	Slag, ash
• liquid phase:		Pyrolysis oil and water	
<i>Source:</i> Adapted from [9, VDI 2002]			

As well as specifically developed pyrolysis/gasification technologies, conventional incineration technologies (i.e. grates, fluidised beds, rotary kilns, etc.) may be adapted to be operated under pyrolytic or gasifying conditions, i.e. with reduced oxygen levels (sub-stoichiometric), or at lower temperatures. Often pyrolysis and gasification systems are coupled with downstream combustion of the syngas generated (see Section 2.3.4.4 on combination processes).

Besides the general objectives of waste incineration (i.e. effective treatment of the waste), the additional aims of gasification and pyrolysis processes are to:

- convert certain fractions of the waste into process gas (called syngas);
- reduce gas cleaning requirements by reducing flue-gas volumes.

Both pyrolysis and gasification differ from combustion in that they may be used for recovering the chemical value of the waste (rather than its energetic value). The chemical products derived may in some cases then be used as feedstock for other processes. However, when applied to wastes, it is more common for the pyrolysis, gasification and a combustion-based process to be combined, often on the same site as part of an integrated process. When this is the case, the installation recovers the energy value rather than the chemical value of the waste, as a conventional incinerator would.

In some cases, the solid residues arising from such processes contain pollutants that, in an incineration system, would be transferred to the gas phase, and then, with efficient flue-gas cleaning, be removed with the FGC residue. [64, TWG 2003]

2.3.4.2 Gasification

Gasification is the partial combustion of organic substances to produce gases that can be used as feedstock (through some reforming processes) or as a fuel. [64, TWG 2003]

There are several different gasification processes available or being developed which are, in principle, suitable for the treatment of municipal wastes, certain hazardous wastes and dried sewage sludge. [1, UBA 2001]

It is important that the properties of the wastes are kept within certain predefined limits. This often requires special pre-treatment of municipal waste.

The special features of the gasification process are:

- smaller gas volume compared to the flue-gas volume in incineration (by up to a factor of 10 by using pure oxygen);
- predominant formation of CO rather than CO₂;
- high operating pressures (in some processes);
- accumulation of solid residues as slag (in high-temperature slagging gasifiers);
- small and compact aggregates (especially in pressurised gasification);
- material and energetic utilisation of the synthesis gas;
- smaller waste water flows from synthesis gas cleaning.

The following gasification reactors are used:

- fluidised bed gasifier;
- current flow gasifier;
- cyclone gasifier;
- packed bed gasifier.

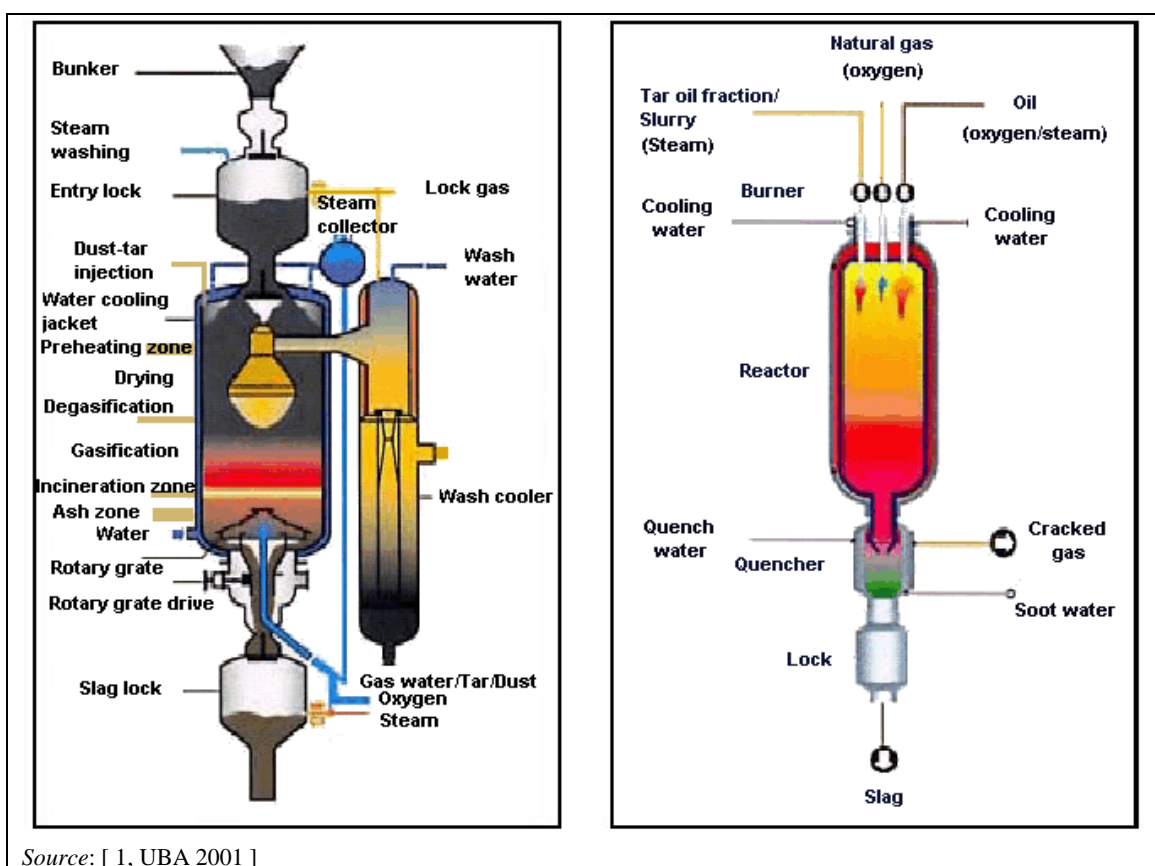

Source: [1, UBA 2001]

Figure 2.15: Representation of a packed bed and current flow gasifier

For utilisation in entrained flow, fluidised bed or cyclone gasifiers, the feed material must be finely granulated. Therefore pre-treatment is necessary, especially for municipal wastes. Hazardous wastes, on the other hand, may be gasified directly if they are liquid, pasty or finely granulated.

2.3.4.3 Pyrolysis

[1, UBA 2001] Pyrolysis is the degassing of wastes in the absence of oxygen, during which pyrolysis gas and a solid coke are formed. The heat values of pyrolysis gas typically lie between 5 MJ/m^3 and 15 MJ/m^3 based on municipal waste and between 15 MJ/m^3 and 30 MJ/m^3 based on RDF. In a broader sense, 'pyrolysis' is a generic term including a number of different technology combinations that constitute, in general, the following technological steps:

- **Smouldering process:** Formation of gas from volatile waste particles at temperatures between $400 \text{ }^\circ\text{C}$ and $600 \text{ }^\circ\text{C}$.
- **Pyrolysis:** Thermal decomposition of the organic molecules of the waste between $500 \text{ }^\circ\text{C}$ and $800 \text{ }^\circ\text{C}$, resulting in the formation of gas and a solid fraction.
- **Gasification:** Conversion of the carbon share remaining in the pyrolysis coke at $800 \text{ }^\circ\text{C}$ to $1\,000 \text{ }^\circ\text{C}$ with the help of a gasification substance (e.g. air or steam) in a process gas (CO , H_2).
- **Incineration:** Depending on the technology combination, the gas and pyrolysis coke are combusted in an incineration chamber.

Pyrolysis plants for waste treatment usually include the following basic process stages:

1. Preparation and grinding: the grinder improves and standardises the quality of the waste presented for processing, and so promotes heat transfer.
2. Drying (depends on process): a separate drying step improves the LHV of the raw process gases and increases the efficiency of gas-solid reactions within the rotary kiln.
3. Pyrolysis of wastes, where in addition to the pyrolysis gas a solid carbon-containing residue accumulates which also contains mineral and metallic portions.
4. Secondary treatment of pyrolysis gas and pyrolysis coke, through condensation of the gases for the extraction of energetically usable oil mixtures and/or incineration of gas and coke for the destruction of the organic ingredients and simultaneous utilisation of energy.

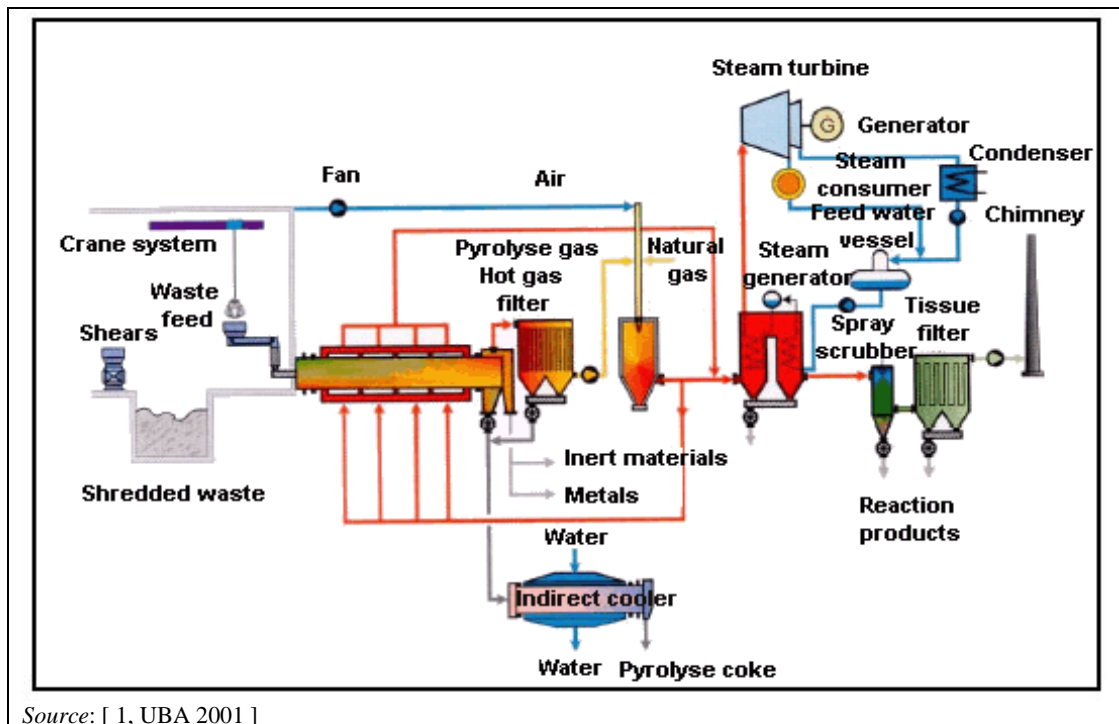

Figure 2.16: Pyrolysis plant for municipal waste treatment

In general, the temperature of the pyrolysis stage is between 400 °C and 700 °C. At lower temperatures (approximately 250 °C), other reactions occur to some extent. This process is sometimes called conversion (e.g. conversion of sewage sludge).

In addition to the thermal treatment of some municipal wastes and sewage sludge, pyrolysis processes are also used for:

- decontamination of soil;
- treatment of synthetic waste and used tyres;
- treatment of cable tails as well as metal and plastic compound materials for substance recovery.

The potential advantages of pyrolysis processes may include:

- the possibility of recovering the material value of the organic fraction, e.g. as methanol;
- the possibility of increased electrical generation using gas engines or gas turbines for generation (in place of steam boilers);

- reduced flue-gas volumes after combustion, which may reduce the FGC capital costs to some degree;
- the possibility of meeting specifications for external use of the produced char by washing (e.g. chlorine content).

[64, TWG 2003], [74, TWG 2004]

2.3.4.3.1 Example of a pyrolysis process

[2, InfoMil 2002]

In this example, solid industrial sludges and shredded paint waste / chemical packaging are treated.

The pyrolysis unit is combined with a thermal treatment plant for polluted soil, in which syngas from the pyrolysis unit is used as fuel. The pyrolysis unit consists of two parallel reactors. Both are equipped with screws, which transport the feed material through the reactors. Feed materials include sludge and sediment of other on-site process waste water treatment facilities, as well as paint waste. The average organic material content varies between 25 % and 85 %, and the average water content is approximately 25 %.

At start-up, the reactors are heated up with natural gas to approximately 500 °C. Then feeding starts and the use of natural gas is stopped. The amount of air is kept below the stoichiometric demand, resulting in a gasification process. The gasification temperature is approximately 900–1 200 °C. The capacity of each reactor is approximately 4 tonnes/hour.

The syngas is cooled down in a quench condenser. The remaining syngas (LHV approximately 7 MJ/Nm³) is used as fuel in another unit for the thermal treatment of polluted soil. Incineration and flue-gas treatment take place according to Dutch emission standards. The condensed water of the quench is treated in a decanter for the separation of carbon. The water fraction is used for moisturising the reactor residues.

The residue of the reactor (temperature level approximately 500 °C) passes a magnetic separation system for removal of the iron from the paint waste and the packaging fraction. The remaining fraction is cooled down and moisturised with condensed water, for disposal to landfill.

A general process scheme, including the main mass flows, is given in the figure below.

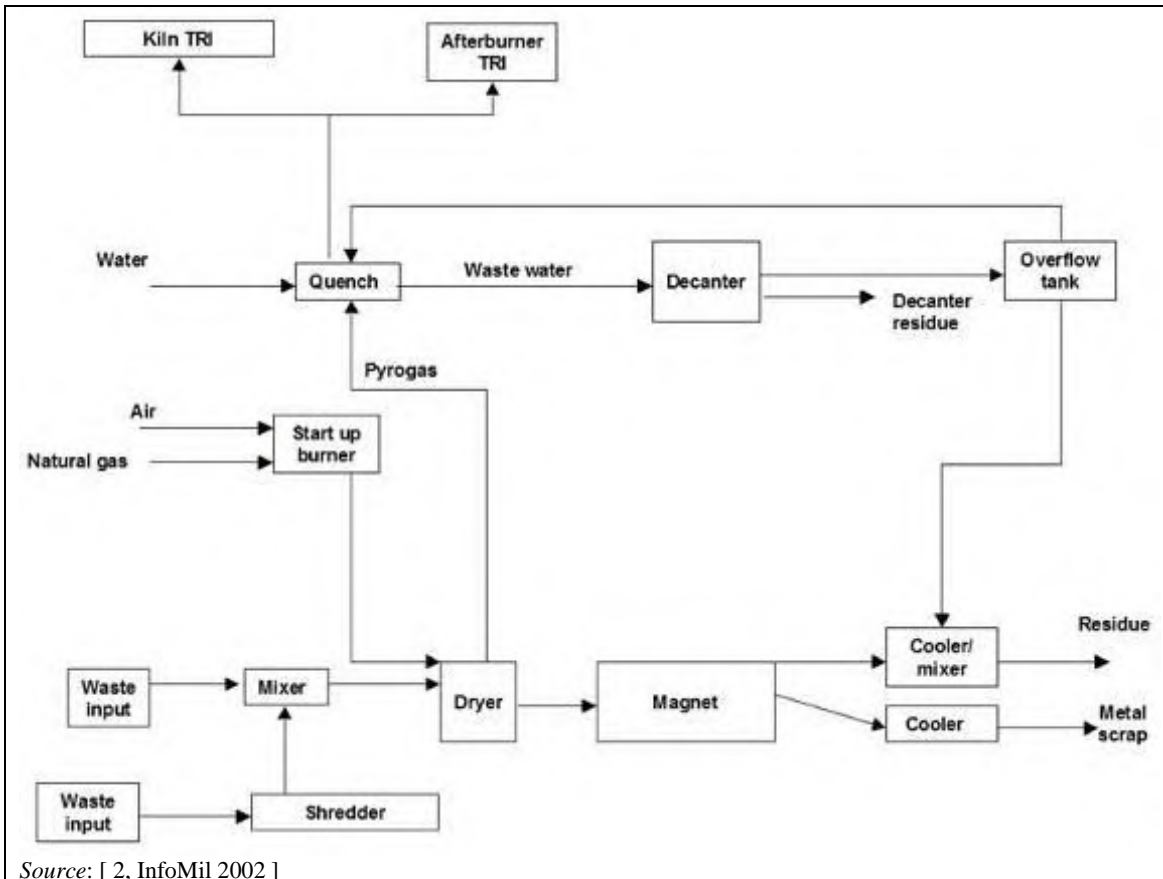

Source: [2, InfoMil 2002]

Figure 2.17: Process scheme of ATM's pyrolysis unit

The main advantage of this pyrolysis unit is that the surplus LHV present in the treated sludge, sediment and paint waste can be used directly in the thermal treatment unit for polluted soil. The energy efficiency, therefore, is at least comparable with that of waste incineration. Furthermore, the iron scrap fraction (15 %) is removed for recycling, while the volume of the treated waste is reduced by approximately 50 %. The remaining residues can partly be treated in ATM's own facilities. Overhead costs are reduced by the fact that it uses the incinerator and flue-gas treatment of a large polluted soil and waste treatment plant.

2.3.4.4 Combination processes

This term is used for processes consisting of a combination of different thermal processes (pyrolysis, gasification, combustion).

2.3.4.4.1 Pyrolysis-combustion

[1, UBA 2001]

The following techniques are at various stages of development:

1. Pyrolysis in a rotary kiln with subsequent high-temperature combustion of pyrolysis gas and pyrolysis coke. In Germany, the full commissioning of a plant of this type was not completed.
2. Pyrolysis in a rotary kiln, followed by condensation of the gaseous tars and oils, and subsequent high-temperature combustion of pyrolysis gas, pyrolysis oil and pyrolysis coke.
3. Pyrolysis on a grate with directly connected high-temperature combustion.

The solid residues from these processes are granular, which can be advantageous for later reutilisation or disposal. Sewage sludge (dehydrated or dried) may be co-treated with the municipal waste fractions.

Process 2 (above) is similar to Process 1 in principle, but differs in two main aspects:

- the pyrolysis gases are cooled on leaving the rotary kiln, to deposit oil, dust and water;
- this is followed by oxidative high-temperature treatment in a special aggregate furnace, where the pyrolysis products, oil-water-dust mixture, pyrolysis coke and pyrolysis gas are combusted, and the solid residues are transformed into a liquid melt.

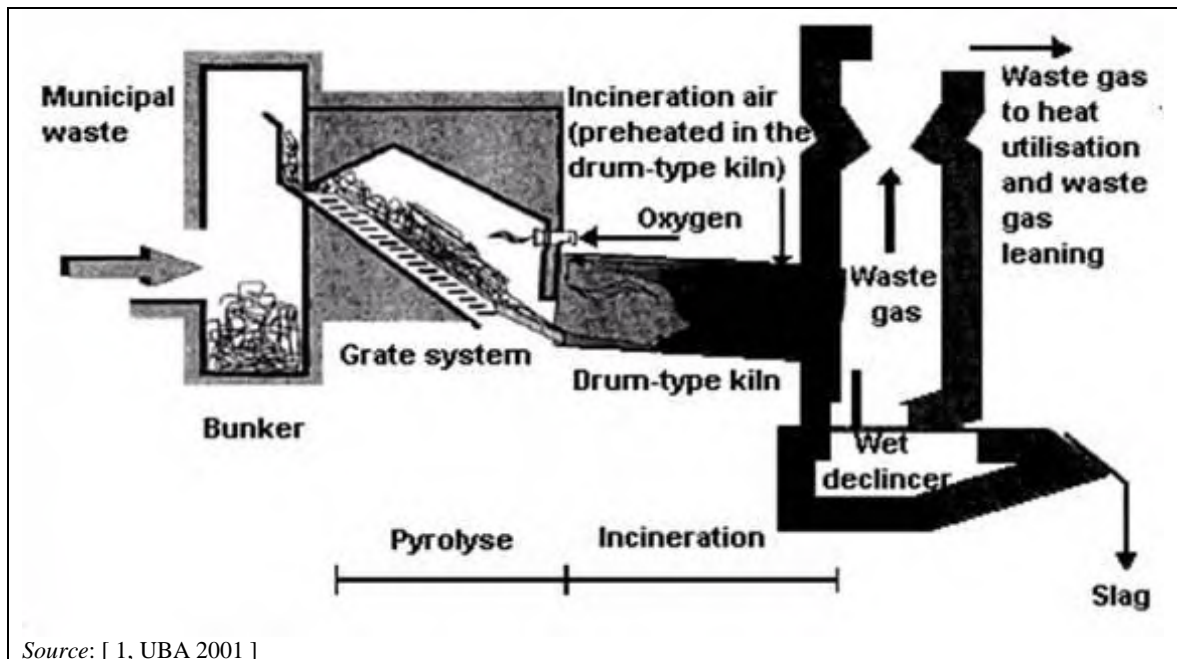

Source: [1, UBA 2001]

Figure 2.18: Pyrolysis on a grate with directly connected high-temperature combustion

Pyrolysis on a grate with directly connected high-temperature combustion (see Figure 2.18) was developed from conventional grate incineration but with the objective of producing a liquid melt. The wastes are first pyrolysed on a grate by direct heating. This heat originates from the partial combustion of the pyrolysis gases with pure oxygen. In a second step, the products, pyrolysis gas, coke and inert substances are combusted or melted, respectively, at high temperatures in a directly connected rotary kiln. The accumulating melt residue contains glass, stones, metals and other inert materials and is different from the corresponding product of Process 1 above.

The flue-gas cleaning techniques applied for the three pyrolysis combination processes named above do not, in principle, differ from the systems used in municipal waste incineration plants. The same residues and reaction products accumulate. Their type and composition mainly depend upon the flue-gas cleaning system selected. However, in contrast to municipal waste incineration, filter dusts can be recycled into the melting chamber.

Example pyrolysis-incineration installation for clinical wastes in the Netherlands

[2, InfoMil 2002]

The non-specific clinical waste is collected regularly from hospitals and other healthcare institutes, including doctors, dentists and veterinarians. The waste is collected in special 30- or 60-litre bins, which have been filled at the institutions and which do not need to be opened again. The waste is then incinerated, including the bins, which also act as an auxiliary fuel.

The non-clinical waste from hospitals and healthcare institutions is collected and treated as normal municipal waste.

The collected waste is stored in closed transport containers on site. The bins are collected and transported semi-automatically to the incineration unit, which is located in a closed building. The incinerator is fed through an airlock, in order to prevent the introduction of false incineration air.

Incineration takes place in a two-stage process (see Figure 2.19). In the lower incineration room, controlled pyrolysis occurs, followed by incineration with primary air as the waste progresses through the room. Finally, the waste ends in a water-filled ash discharger, from which the ash is removed by a chain conveyer system.

The flue-gases are incinerated with secondary air and, if required, with auxiliary fuel at a temperature of approximately 1 000 °C. Subsequently, they are cooled in a saturated steam boiler (steam temperature 225 °C, pressure 10 bar), a heat exchanger and a scrubber. Steam is supplied to the adjacent municipal waste incineration plant which uses the steam and returns the boiler feed water.

The scrubber is a two-stage system for removing acid compounds. The treated flue-gas is heated up (in a heat exchanger and in a steam-flue-gas heat exchanger) before passing a dust bag filter with adsorbent injection (activated carbon and hydrated lime), for removal of dioxins, and a SCR de-NO_x unit. Emission concentrations of the emitted flue-gases comply with Dutch standards. The flue-gas is emitted through a 55-metre high stack.

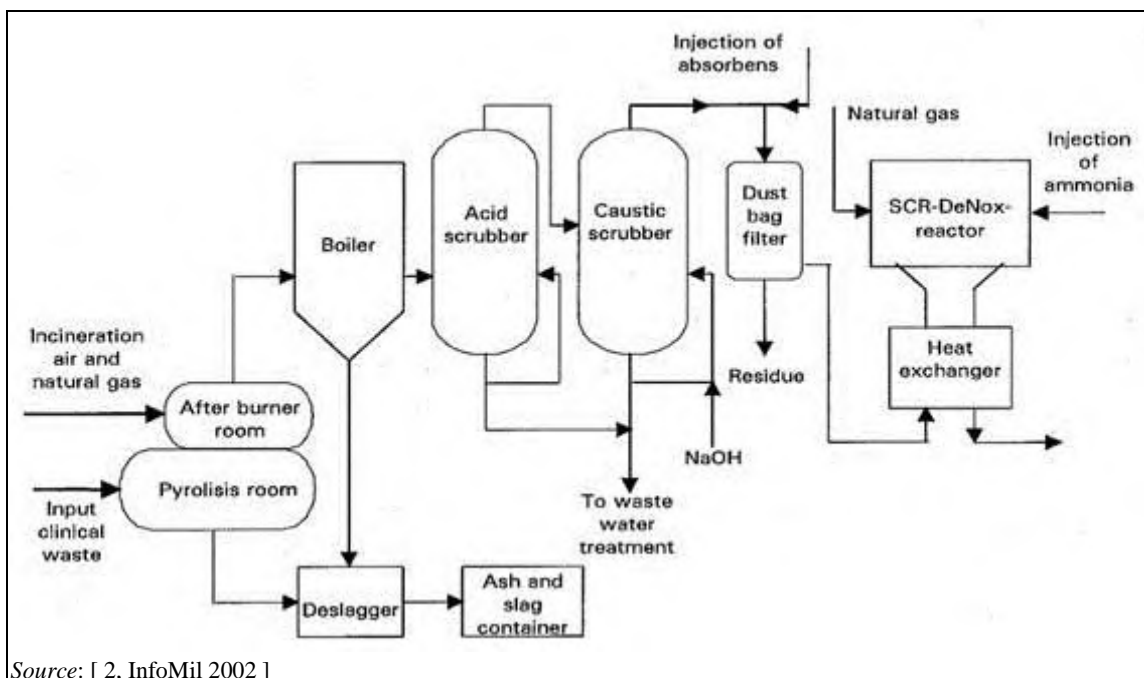

Source: [2, InfoMil 2002]

Figure 2.19: Example of a clinical waste pyrolysis-incineration plant, ZAVIN, Netherlands

2.3.4.4.2 Pyrolysis-gasification

[1, UBA 2001]

Two different types of pyrolysis-gasification processes can be distinguished:

- disconnected (pyrolysis with subsequent gasification = conversion process); and
- directly connected.

Conversion process

In the conversion process, metals and, if required, inert material may be removed after the pyrolysis step. As pyrolysis gas and pyrolysis coke require reheating in the gasification process, the technical and energetic requirements are higher than with connected processes. The condensed exhaust vapour is treated as waste water and discharged.

In the conversion process, the waste needs to be shredded and dried before it can be used in the first thermal stage. This stage more or less corresponds to that of the 'Smoulder-burn' process. The subsequent stages are:

- pyrolysis in the kiln;
- removal of solid residues;
- separation of the fine fraction enriched with carbon;
- sorting of the metal and inert fraction.

The pyrolysis gas is cooled to condense exhaust vapour and pyrolysis oil. It is then supplied, together with the pyrolysis oil and the fine fraction, to the second thermal stage, which is a current flow gasifying reactor. The oil and the fine fraction are gasified in the current flow at high pressure and at a temperature of 1 300 °C. The resulting syngas is cleaned and then combusted for energy recovery. Solid residues are withdrawn as melted granulate through a water bath. They correspond in type and quantity to those from the 'Smoulder-burn' process.

With direct connection, there may be improved electricity generation rates, but the metals and inert material go into a melt for which no use has been found to date.

Combined gasification-pyrolysis and melting process

In such processes, (see Figure 2.20) the unshredded wastes are dried in a push furnace and partially pyrolysed. From this furnace they are transferred directly and without interruption into a standing packed bed gasifier. Here they are gasified (in the lower part) at temperatures of up to 2 000 °C with the addition of oxygen. Pure oxygen is also added in the upper part of the gasification reactor to destroy the remaining organic components in the generated syngas, through oxidation, gasification and cracking reactions.

Although reported to be capable of treating a wider range of wastes, this process is mainly used for municipal and non-hazardous industrial wastes. Wastes with a LHV of 6–18 MJ/kg and a moisture content up to 60 % may be treated. Automotive shredder residues with a chlorine content of up to 3.5 % have been treated with approximately equal amounts of MSW [69, Thermoselect 2003].

The syngas is subjected to a gas cleaning process and then combusted to utilise the energy value. The originally solid residues leave the reactor molten. During test operations, approximately 220 kg of bottom ash with approximately 30 kg metal accumulated per tonne of waste input.

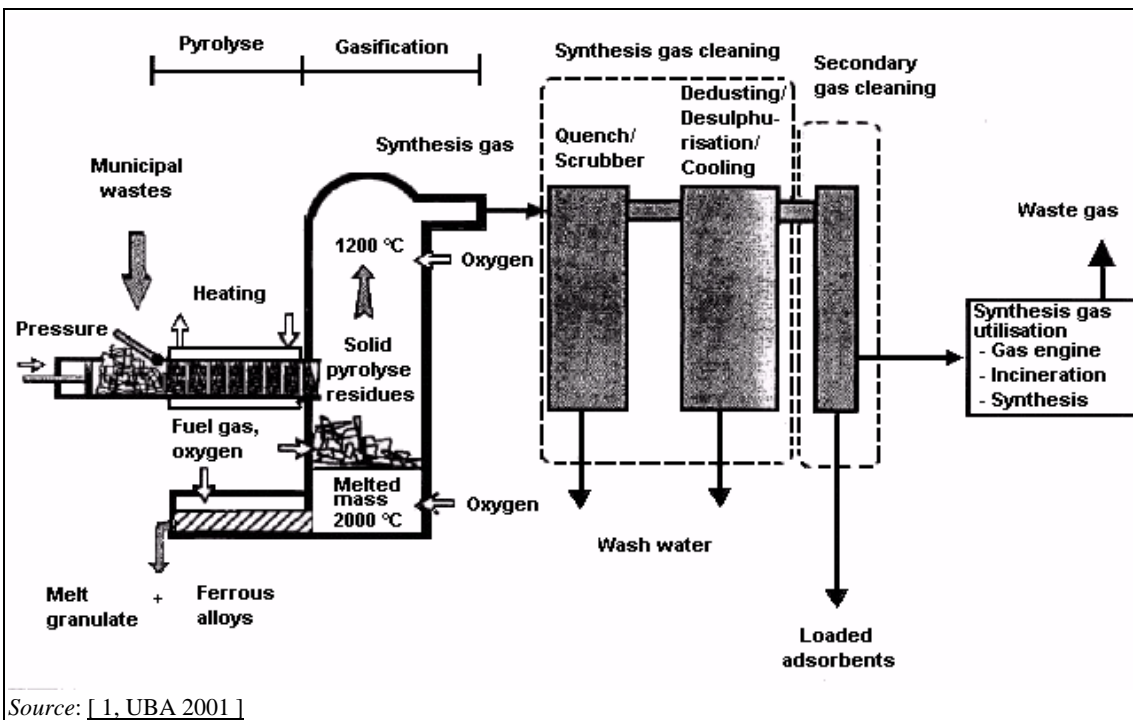

Figure 2.20: Schematic diagram of a push pyrolyser (example shown operated by Thermostelect)

Two plants of this type were operated in Japan as of 2003. Two plants of this type were also built in Europe but ceased operation after some years. [47, TWG 2018].

2.3.4.4.3 Gasification-combustion

Two different types of gasification-combustion processes can be distinguished:

- fluidised bed gasifier and ash melting furnace (two separate stages);
- shaft furnace (single integrated stage).

Fluidised bed gasifier and ash melting furnace

An example of the fluidised bed gasifier and ash melting furnace combination is shown in Figure 2.21.

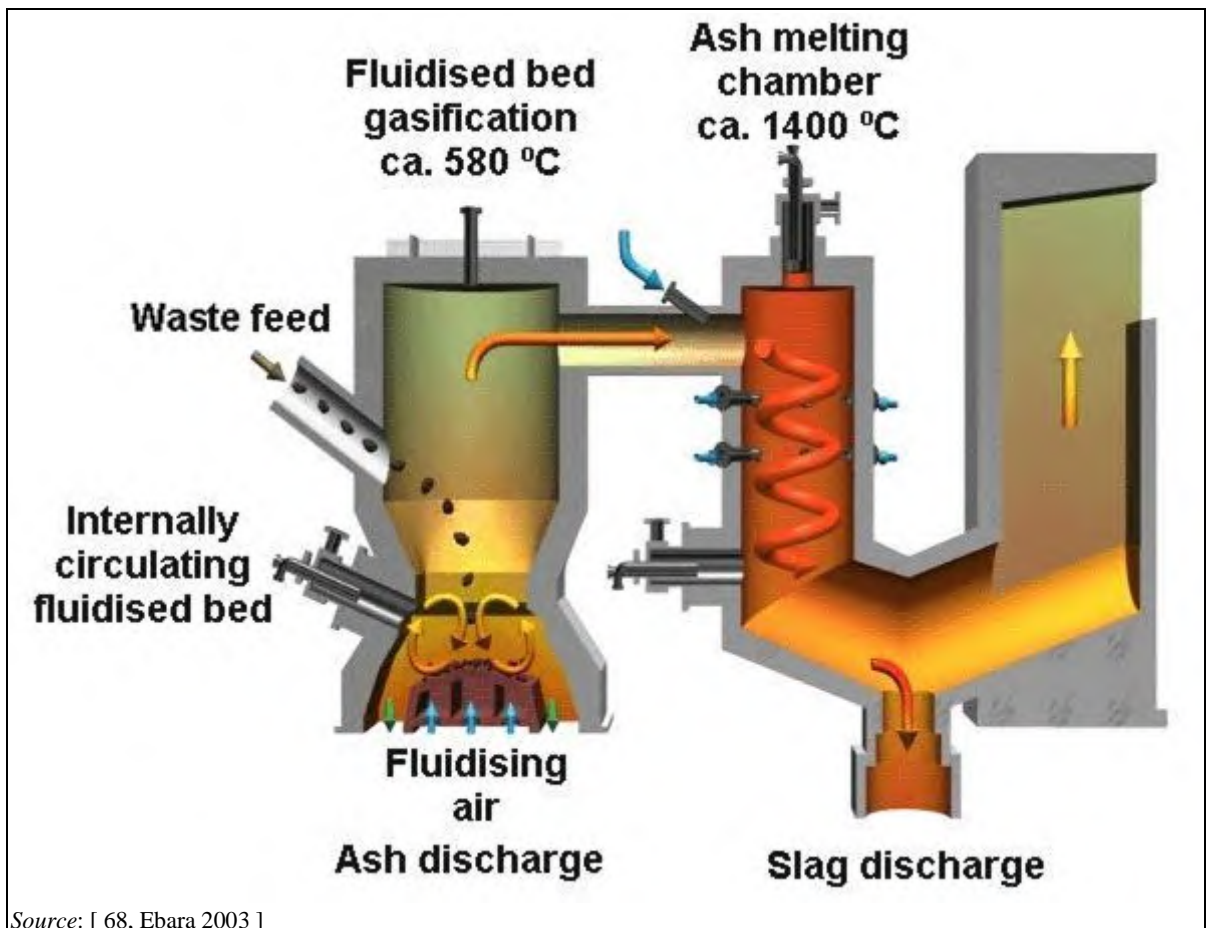

Figure 2.21: Combined fluidised bed gasification and high-temperature combustion process

In this plant type, shredding residues, waste plastics or shredded MSW are gasified in an internally circulating bubbling fluidised bed, which is operated at about 580 °C. Larger inert particles and metals are discharged at the bottom and separated from the bed material. The bed material is returned to the gasifier. Fine ash, small char particles and combustible gas are transferred to the cyclonic ash melting chamber, where air is added to achieve the desired temperature for ash melting (normally 1 350–1 450 °C).

The ash melting chamber is an integrated part of the steam boiler, for energy recovery.

Products from this process – besides power or steam – are metal fragments, a vitrified slag (low leaching and stable) and metal concentrates derived from the secondary ash.

In contrast to other gasification processes, this process is operated at atmospheric pressure and with air rather than oxygen. Pre-treatment of MSW by shredding is necessary to reduce the particle size to 300 mm in diameter. Wastes already within this specification can be treated without shredding. In the various plants in operation, other wastes like sewage sludge, bonemeal, clinical waste and industrial slags and sludges are treated in addition to MSW.

[68, Ebara 2003]

Shaft furnace

Compared to the gasification and melting process described in Figure 2.21, the structure of this process (see Figure 2.22) is simpler as gasification and melting are carried out in a single furnace.

Combustible fractions from unshredded MSW will be gasified by the high temperature of the furnace and converted into a syngas to be used for power generation. Non-combustibles (metal and mineral components) will be melted in the melting zone at the bottom of the furnace and turned into metal and vitrified slag.

The pre-shredding of MSW is not necessary as long as the size of the MSW plastic bags is 600 x 600 x 600 mm or less.

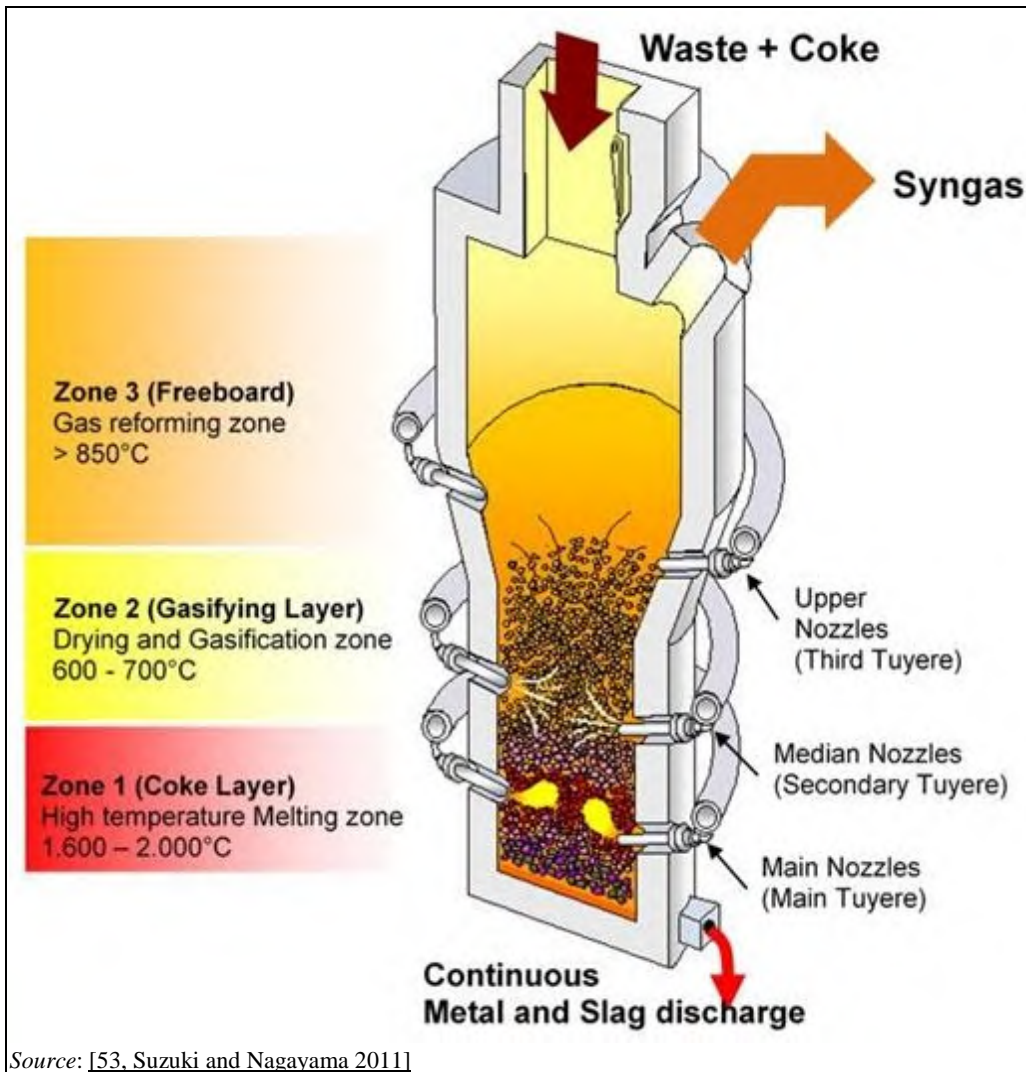

Figure 2.22: Shaft furnace for integrated waste gasification and ash melting

Waste is fed into the furnace together with coke (approximately 5 mass-% and 15 energy-% of the waste) and limestone (approximately 3 mass-% of the waste) from the top of the furnace. Since the furnace is operated in a reducing atmosphere, metals are vaporised to the gaseous phase and the molten ash is converted to a vitrified slag. The molten ash from the furnace bottom is quenched in a water-granulation conveyor to be converted into vitrified slag and metals.

The furnace can be divided in three zones:

- Zone 1 is filled with coke, and the coke and waste's carbon are burned with oxygen-enriched air (approximately 35 % O₂) fed through the main nozzle into the lower part of the furnace. Air is introduced into the furnace through the main, secondary and third nozzles located along the furnace wall. The zone 1 temperature exceeds 2 000 °C. At such a high temperature, non-combustibles in the waste are melted, and then continuously discharged through a slag outlet at the bottom of the furnace while they are kept molten at around 1 600 °C. The CO₂ generated is reduced to CO by a solution-loss reaction with coke, and CO flows into the upper zone (2) at a temperature of around 1 000 °C.
- In zone 2, the gas produced in the lower zone is partially burned and kept at a temperature of around 700 °C with air fed through the secondary nozzle while maintaining the waste, coke and limestone, which are charged from the top of the furnace, in a fluidised state. In this zone, the wastes are preheated and thermally decomposed.
- In zone 3, part of the gas produced is burned in a reducing atmosphere at a temperature above 850 °C by air sent through the third nozzle. A residence time of two seconds or longer enhances the pyrolysis of tar and prevents the formation of dioxins. This process improves the quality of the syngas produced.

The syngas exiting the furnace is introduced into the secondary combustion chamber before the boiler, where the syngas undergoes complete combustion.

The first plant treating MSW using this technology was in commercial operation in 2003. There are 11 plants of this type in operation in Japan. [53, Suzuki and Nagayama 2011]

2.3.5 Other techniques

2.3.5.1 Incineration chambers for liquid and gaseous wastes

Incineration chambers are designed specifically for the incineration of liquid and gaseous wastes, as well as solids dispersed in liquids (see Figure 2.23) A common application of incineration chambers is in the chemical industry for the incineration of liquid and process off-gas. With chloride-containing wastes, HCl may be recovered for use.

All post-combustion chambers in hazardous waste incineration plants are essentially incineration chambers. In one plant (Ravenna, Italy), the post-combustion chamber is so large that the whole thermal process can occur there.

Operational temperatures are usually chosen to ensure good destruction of the wastes fed to the chamber. In some cases, catalytic systems are used for specific waste streams; these run at reduced temperatures of 400–600 °C. In general, temperatures in excess of 850 °C are selected for non-catalytic chambers. Support fuels are frequently used to maintain steady combustion conditions. Heat recovery may be used to supply hot water/steam via a boiler system.

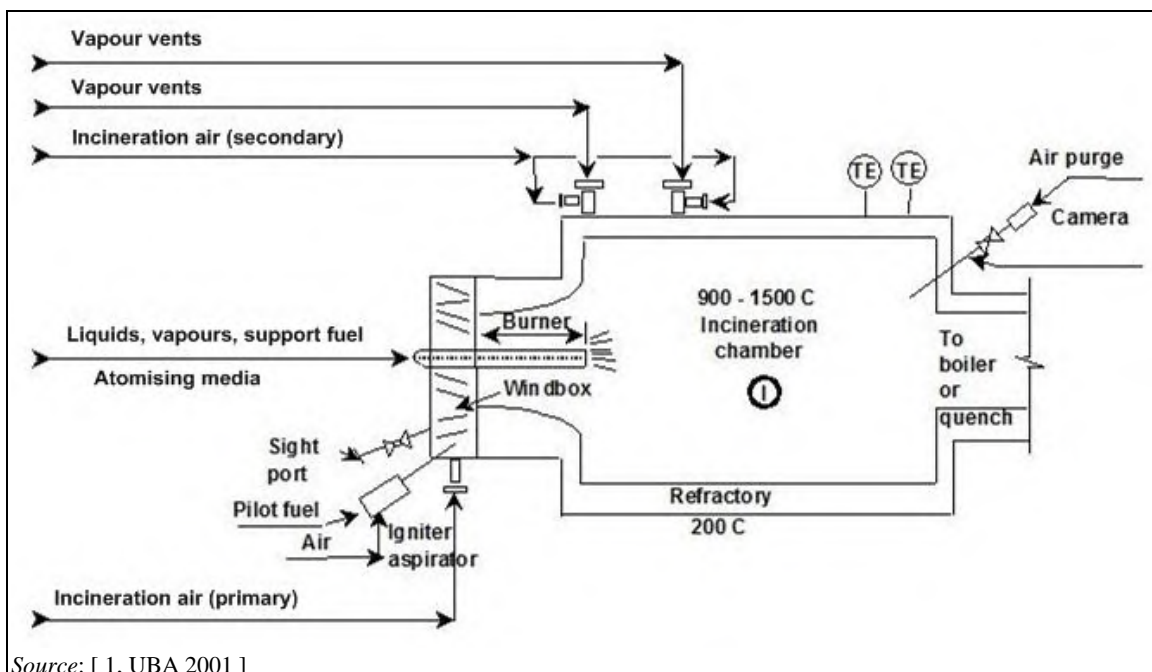

Figure 2.23: Typical design of an incineration chamber for liquid and gaseous wastes

2.3.5.2 Incineration of liquid and gaseous chlorinated wastes with HCl recovery

[1, UBA 2001] The process includes:

- the incineration chamber;
- a steam generator;
- a flue-gas cleaner combined with hydrochloric acid recovery; and
- the flue-gas chimney (see Figure 2.24).

The plant treats liquid and gaseous chlorinated wastes using waste heat and produces hydrochloric acid.

Heat is converted into steam in the steam generator (212 °C, 20 bar) and transferred, for distribution. The particulate content of the flue-gases produced during incineration is separated, to produce the highest possible concentration of hydrochloric acid in the flue-gas cleaning plant. The removal and utilisation of hydrochloric acid normally occurs within the plant.

Gaseous residual substances (flue-gases) are fed to the recovery plant via transfer pipelines. Each flue-gas flow is conducted through a separate deposit container before incineration. Liquid particles are separated from the flue-gas flow in this deposit container. The feed lines are equipped with the appropriate flashback safety guards, according to the classification of the flue-gases. The number of feed lines depends on the control mechanisms. The volume flow is collected via flow measurements that are pressure- and temperature-compensated. The flue-gases are fed into the incineration chamber via a pressure regulator with a maximum pressure limit control. In addition, all flue-gas lines to the incineration chamber are equipped with automatic emergency shutdown valves.

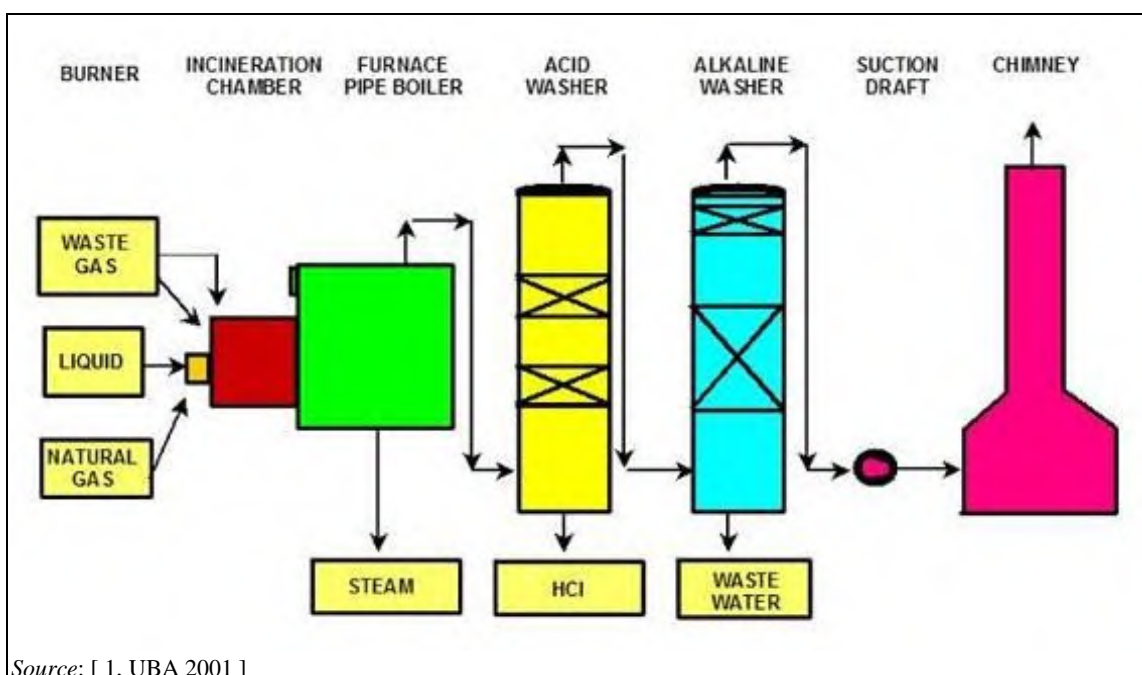

Figure 2.24: Diagram of a plant for HCl extraction from residual gases and liquid halogenated wastes

Transfer pipelines for the liquid wastes are also equipped with automatic emergency shutdown valves. All liquid wastes are conducted to a multi-material burner that is situated at the front of the incineration chamber. Vaporisation of these liquids occurs via pressured air and/or steam that has been fed into the burner under a separate gas quantity control. In addition, various flue-gas flows are fed into the multi-material burner through lances. Each of these lances consists of concentric pipes. Several flue-gas flows can thus be fed separately into the incineration chamber. For cooling and to avoid corrosion, the lances are continuously sprayed with air through the outer circular gap.

Primary energy (natural gas) is required for the plant start-up and to maintain the desired temperature in the incineration chamber. It is also fed to the multi-material burner by a separate blast connection. The flow of natural gas is regulated via a quantity control computer system and is fed into the burner using a pressure regulator depending on the temperature in the incineration chamber. Natural gas is also required for the ignition flame that ignites the multi-material burner. Two automatic emergency shutdown valves with automatic gap releases can be found in the natural gas line to the multi-material burner and to the ignition flame.

Two independent flame-failure alarms (UV and IR) are installed to monitor the burner flame. In addition, the burner flame can be observed through inspection windows and with the help of a television camera installed on the back wall of the waste heat boiler. The amount of air is recorded with the appropriate gauges, as well as with pressure produced from a blower.

The cylindrical incineration chamber is designed in such a way that the wastes will have sufficient residence time to guarantee complete incineration with an operational temperature higher than 1 100 °C during normal operation. The incineration chamber is designed for a temperature of 1 600 °C. The operational temperature is monitored continuously. To withstand this high temperature, the whole incineration chamber, up to the entrance to the steam boiler plant, is lined with refractory bricks. The incineration chamber shell is made of boilerplate. The wet cleaning of the flue-gases occurs in two wash towers with a simultaneous recovery of technically reusable hydrochloric acid of the highest possible concentration. The incineration of chlorinated wastes may allow the recovery of approximately 5–20 % hydrochloric acid.

2.3.5.3 Incineration of chlorinated liquid wastes with chlorine recycling

[2, InfoMil 2002]

This incineration unit for highly chlorinated liquid wastes (chlorinated hydrocarbons) is located on an industrial site. The total plant capacity is approximately 36 000 t/yr. The processed waste originates on site, as well as from external customers. Wastes are limited in their content of solids (< 10 g/kg), fluorine, sulphur and heavy metals. PCBs are also treated.

Incineration takes place in two furnaces at a temperature of 1 450–1 550 °C (gas residence time 0.2–0.3 seconds). This temperature level can normally be maintained without auxiliary fuel. Water is injected in order to suppress the formation of Cl_2 . After leaving the furnace, the flue-gas passes through a quench section, where the temperature is lowered to approximately 100 °C. Insoluble matter and heavy metal salts are removed from the circulating liquid in a quench tank. The flue-gas continues through an isothermal and an adiabatic absorber. The recuperated hydrochloric acid is distilled at elevated pressure and temperature, after which the gas is cooled down to -15 °C in order to reduce the water content to practically zero. The recovered anhydrous HCl is reprocessed in a vinyl chloride monomer plant.

Flue-gases pass through an alkaline scrubber and an activated carbon filter (for dioxin absorption). TOC, HCl, NO_x , O_2 , CO and dust are continuously analysed. The concentration of dioxins and PCBs in emissions is below 0.1 ng TEQ/ Nm^3 .

The effluent from the quench and the scrubber unit is treated in a physical/chemical unit and in a biological waste water treatment unit. The dioxin content is < 0.006 ng TEQ/l. PCBs are below the limit of detection (< 10 ng/l).

A scheme of the process is given in Figure 2.25.

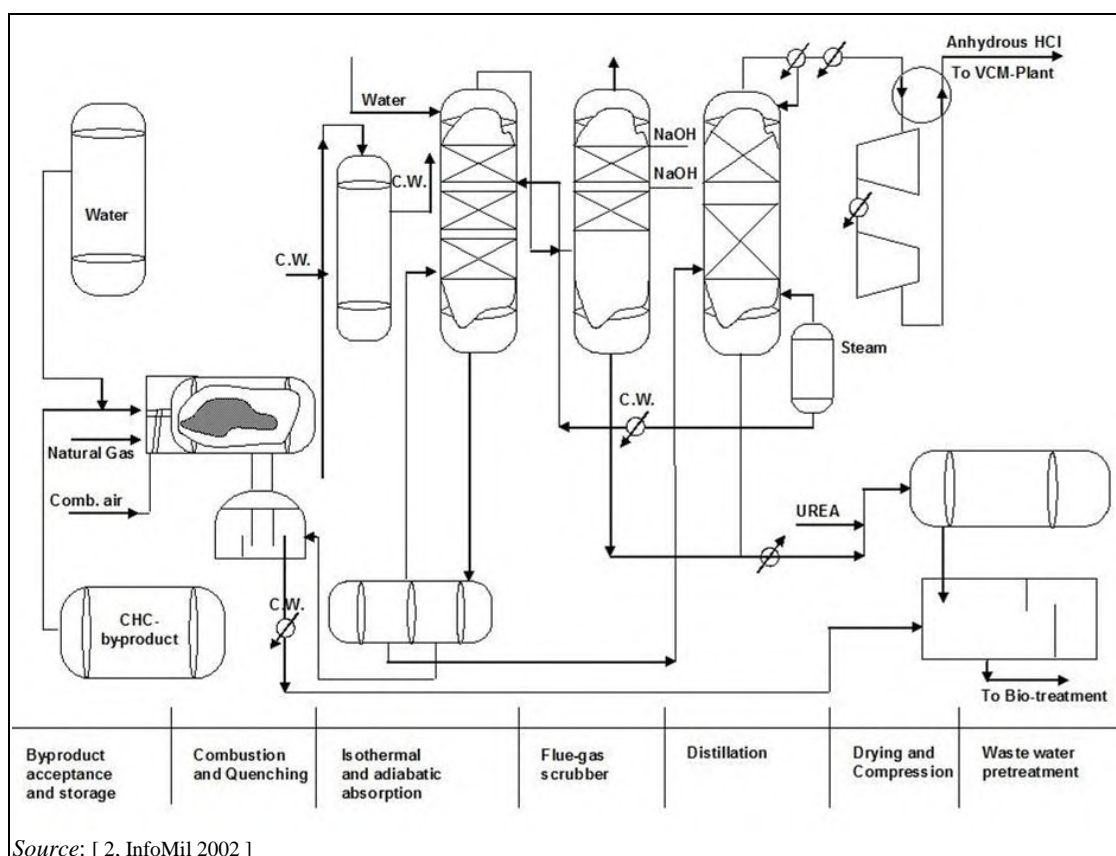

Figure 2.25: Process scheme of a chlorine recycling unit operated by AkzoNobel

The main advantage of this dedicated incineration unit is that chlorine can be recovered. Also, in this case, overhead costs are reduced by the fact that it is part of a larger chemical plant.

2.3.5.4 Waste water incineration

[1, UBA 2001]

Waste water can be treated through incineration of the organic materials. This is a special technology for the treatment of industrial waste water where organic and sometimes inorganic material is chemically oxidised with the help of atmospheric oxygen with the evaporation of the water, at high temperatures. The term 'gas phase oxidation' is used to differentiate this type of incineration from other technologies, such as wet oxidation. The process of gas phase oxidation is used if the organic substances in the water cannot be reused or if their recovery is not economical or another technique is not applied.

Unsupported incineration can only take place if the organic load is sufficient to evaporate the water share independently and to perform superheating. The calorific value of the water is normally too low for unsupported incineration, in which case co-incineration or the use of support fuel will be necessary. Reduction of the requirement for additional energy can be achieved by reducing the water content. This can be achieved through deployment of a pre-connected, or multi-step, condensation plant. In addition, a heat recovery part (boiler) can be installed to recover steam for condensation from the furnace heat that is produced.

Depending on the individual organic and inorganic content of the waste water and the various local conditions, very different plant designs result.

Waste water and fuel are injected via burners or lances at several locations within the incineration chamber. Atmospheric oxygen is also supplied at several locations (primary air = atmospheric oxygen combined with fuel, secondary air = mixed air).

An example of a waste water incinerator with a waste water evaporation (concentration) unit is shown in the figure below. [74, TWG 2004]

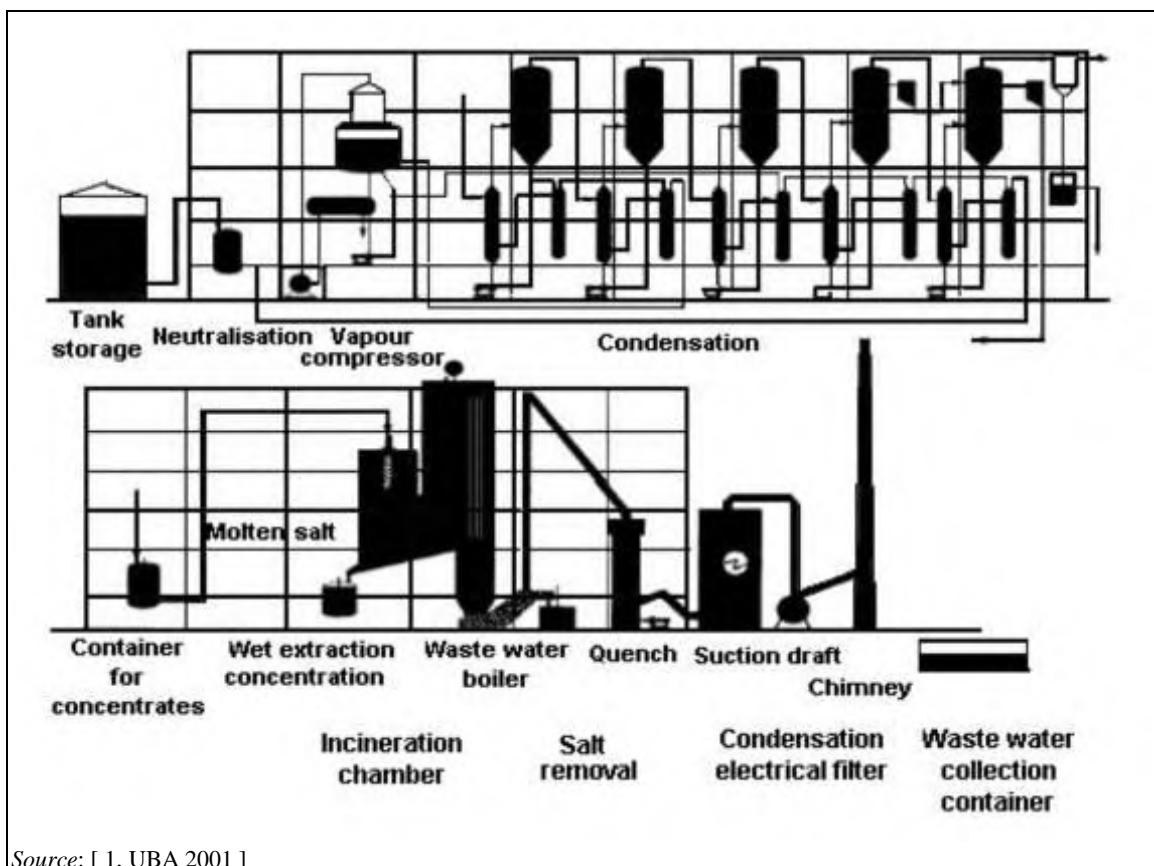

Source: [1, UBA 2001]

Figure 2.26: Example of a waste water incinerator with a waste water evaporation (concentration) unit

Example of an installation for the incineration of caustic waste water

[2, InfoMil 2002]

Caustic water is a specific waste water stream from monostyrene propylene oxide (MSPO) plants. This water is produced in several washing steps in the process. It contains approximately 10–20 % organic components and has a high sodium load (mainly NaCl).

Both the high organic fraction and the sodium make it difficult or even impossible to use biological water treatment. The calorific value of this water is too low for unsupported incineration, so co-incineration or the use of support fuel is necessary. The high sodium content, together with the large quantities, can cause problems for co-incineration in municipal waste incinerators.

Applicable treatment technologies are wet oxidation and incineration. For this purpose, four static vertical incinerators (total capacity approximately 350–400 kt/yr) are used in this example, which have been in operation since 1999/2000.

The low calorific value waste (caustic water with 10–20 % organics) can be passed through a falling film evaporator. This evaporator operates on excess low-pressure steam, which comes from the incinerator wall cooling, thus using less fuel in the incinerator.

The remaining liquid and the produced vapour are incinerated using static vertical top-down incinerators with natural gas and/or high calorific value liquid fuel (waste or fuel oil). The resulting flue-gases are partially cooled by a membrane wall, producing steam at 27 bar. Subsequently, the flue-gases are quenched to clean the gases of sodium salts and other water-soluble impurities.

In the heat recovery section, recirculation water is sprayed over the flue-gases. This recirculation water flashes out in the flash chamber, generating approximately 30 t/h of steam per unit.

After the heat recovery, the flue-gases pass through a venturi scrubber and a wet electrostatic precipitator where aerosols and dust are removed.

The incinerators operate at a temperature of 930–950 °C, with low excess air (3–4 % O₂). Depending on the concentration of organics, the throughput of caustic water is 10–15 t/h per unit.

The water from the quench is treated in ion exchange beds to remove heavy metals. Special ion exchange beds concentrate the molybdenum (catalyst in the MSPO process) to a reusable grade.

The main advantage of these incinerators is their ability to incinerate large quantities of low calorific value waste with high salt concentrations.

The following diagram shows an example plant for this process.

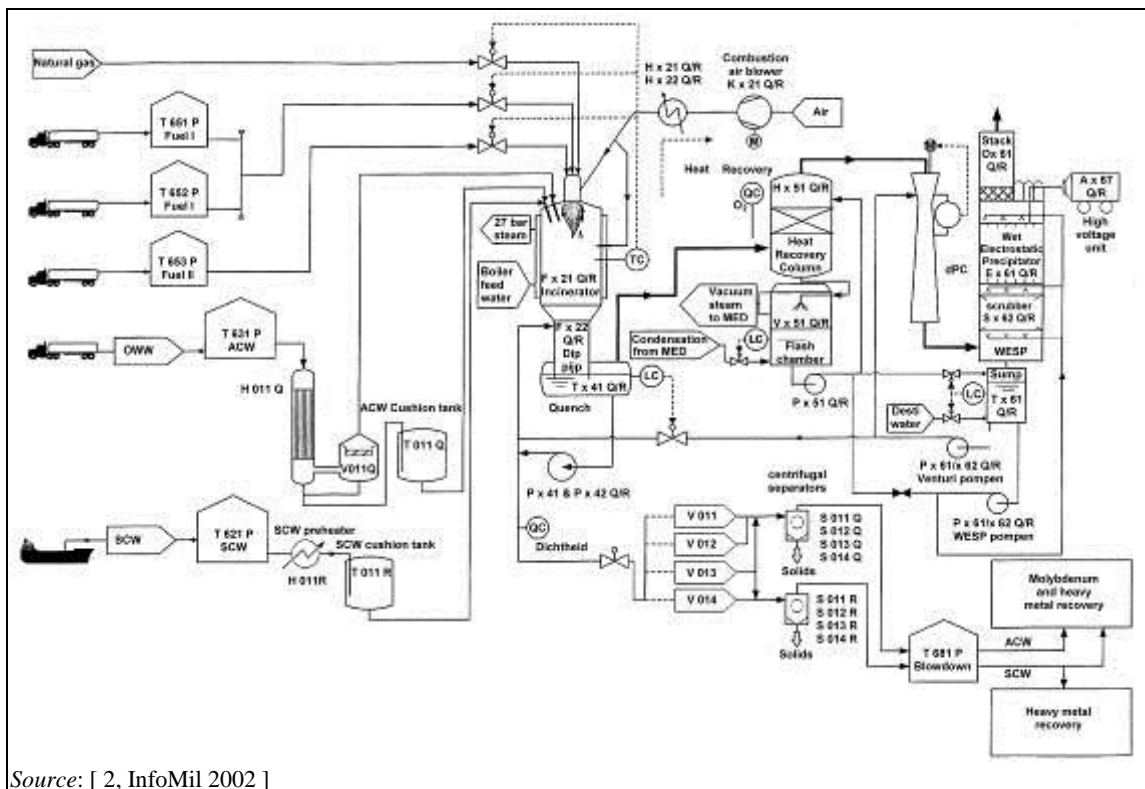

Figure 2.27: Process scheme of a caustic water treatment plant operated by AVR

2.3.5.5 Plasma processes

Plasma is a mixture of electrons, ions and neutral particles (atoms and molecules). This high-temperature, ionised, conductive gas can be created by the interaction of a gas with an electric or magnetic field. Plasmas are a source of reactive species, and the high temperatures promote rapid chemical reactions.

Plasma processes utilise high temperatures (5 000 °C to 15 000 °C), resulting from the conversion of electrical energy to heat, to produce a plasma. They involve passing a strong electric current through an inert gas stream.

Under these conditions, hazardous contaminants, such as PCBs, dioxins, furans and pesticides, are broken into their atomic constituents, by injection into the plasma. The process is used to treat organics, metals, PCBs (including small-scale equipment) and hexachlorobenzene. In many cases, pre-treatment of wastes may be required.

A waste gas cleaning system is normally required depending on the type of wastes treated, and the residue is a vitrified solid or ash. Plasma processes enable high destruction efficiencies, > 99.99 %. While the plasma process is an established commercial technology, it can be very complex, expensive and operator-intensive.

Thermal plasmas can be generated by passing a DC or AC electric current through a gas between electrodes, by the application of a radio frequency (RF) magnetic field without electrodes, or by application of microwaves. Different kinds of plasma technologies are introduced below.

1. Argon plasma arc

This is an 'in flight' plasma process, which means that the waste mixes directly with the argon plasma jet. Argon was selected as the plasma gas since it is inert and does not react with the torch components.

The destruction and removal efficiency (DRE) is reported to exceed 99.9998 % for destroying ozone-depleting substances (ODS) at 120 kg/h and with 150 kW electrical power.

The advantage of this technology over some other plasma systems is that it has demonstrated high-efficiency destruction of both CFCs and halons on a commercial scale for several years. It has also demonstrated low emissions of PCDD/F. Mass emissions of pollutants are also low because of the relatively low volume of flue-gas produced by the process. Also, the very high energy density results in a very compact process that may be easily transported.

2. Inductively coupled radio frequency plasma (ICRF)

In ICRF applications, inductively coupled plasma torches are used, and energy coupling to the plasma is accomplished through the electromagnetic field of the induction coil. The absence of electrodes allows operation with a large range of gases, including inert, reducing or oxidising atmospheres and better reliability than plasma arc processes.

The ICRF plasma process has demonstrated a DRE exceeding 99.99 % while destroying CFCs at a rate of 50–80 kg/h.

The process is reported to have been demonstrated on a commercial scale to achieve high destruction of CFCs and low emission of pollutants. The ICRF plasma does not require argon and may therefore cost less to operate than other similar systems. In addition, the low volume of gas produced by the process results in low levels of mass emissions of pollutants.

3. AC plasma

The AC plasma is produced directly with 60 Hz high-voltage power but in other respects is similar to the inductively coupled RF plasma. The system is electrically and mechanically simple and is thus claimed to be very reliable. The process does not require argon and can tolerate a wide variety of working gases, including air or steam, as plasma gases and is claimed to be tolerant of oil contamination in ODS.

4. CO₂ plasma arc

A high-temperature plasma is generated by sending a powerful electrical discharge into an inert atmospheric gas, such as argon. Once the plasma field has been formed, it is sustained with ordinary compressed air or certain atmospheric gases depending on the desired process outcomes.

The temperature of the plasma is well over 5 000 °C at the point of generation into which the liquid or gaseous waste is directly injected. The temperature in the upper reactor is about 3 500 °C and decreases through the reaction zone to a precisely controlled temperature of about 1 300 °C.

A special feature of the process is the use of CO₂, which is formed from the oxidation reaction, as the gas to sustain the plasma.

The process has demonstrated high DREs with refractory compounds at a reasonably high demonstration rate. Mass emission rates of the pollutants of interest are low, primarily because of the low volume of flue-gas produced by the process.

5. Microwave plasma

This process feeds microwave energy at 2.45 GHz into a specially designed coaxial cavity to generate a thermal plasma under atmospheric pressure. Argon is used to initiate the plasma but otherwise the process requires no gas to sustain the plasma.

The DRE for the microwave plasma process is reported to exceed 99.99 % while destroying CFC-12 at a rate of 2 kg/h.

The process is reported to have a high destruction efficiency and to be capable of achieving the high operating temperatures in a very short time, thus providing operating flexibility and reduced downtime.

There is no need for an inert gas to operate the process, which improves the power efficiency, reduces operating costs and reduces the volume of flue-gas produced. In addition, the process is very compact.

6. Nitrogen plasma arc

This process uses a DC non-transferred plasma torch operating with water-cooled electrodes and using the nitrogen as the working gas to generate the thermal plasma.

The process is reported to achieve a DRE of 99.99 % while destroying CFCs, HCFCs and HFCs at a feed rate of 10 kg/h.

A key advantage of this technology is that the equipment is very compact in size. The system requires only a 9 m x 4.25 m area for installation, which includes space for a precipitation and dehydration unit for the by-products (CaCl_2 and CaCO_3). Therefore, the system is capable of being carried on a truck to treat waste on the site where it is produced.

2.4 The energy recovery stage

2.4.1 Introduction and general principles

[28, FEAD et al. 2002]

Combustion is an exothermic (heat-generating) process. The majority of the energy produced during combustion is transferred to the flue-gases. Cooling of the flue-gas allows:

- recovery of the energy from the hot flue-gases; and
- cleaning of flue-gases before they are released to the atmosphere.

In plants without heat recovery, the gases are normally cooled by the injection of water, air, or both.

The majority of plants carry out heat recovery using a boiler, which has two interconnected functions:

- to cool the flue-gases;
- to transfer the heat from the flue-gases to another fluid, usually water which, most often, is transformed inside the boiler into steam.

The characteristics of the steam (pressure and temperature) or of the hot water are determined by the local energy requirements and operational limitations.

The design of the boiler will mainly depend on:

- the steam characteristics;
- the flue-gas characteristics (corrosion, erosion and fouling potential).

The flue-gas characteristics are themselves highly dependent upon the waste content. Hazardous wastes, for example, tend to have very wide variations in composition and, at times, very high concentrations of corrosive substances (e.g. chlorides) in the raw gas. This has a significant impact on the possible energy recovery techniques that may be employed. In particular, the boiler can suffer significant corrosion at high temperatures, so it is usually designed to operate at a lower temperature which produces lower pressure steam.

- Similarly, the thermal cycle (steam-water cycle) for each plant will depend on the relative importance of producing electricity, steam and/or hot water.

Water walls (the walls of the combustion chamber are made of water-filled heat-exchange pipes - usually with a protective coating of some type) are widely used to cool the combustion gases in the empty (i.e. of heat-exchange bundles) boiler passes. The first pass generally needs to be empty as hot gases are too corrosive and dust is too sticky for the effective use of heat-exchange tubes in this area.

Depending on the nature of the waste incinerated and the combustor design, sufficient heat may be generated to make the combustion process self-supporting (i.e. non-waste fuels will not be required).

The principal uses of the energy transferred to the boiler are:

- production and supply of heat (as steam or hot water);
- production and supply of electricity;
- combinations of the above.

The energy transferred may be used on site (thus replacing imported energy) and/or off site. The energy supplied may be used for a wide variety of other processes. Commonly, heat and steam are used for industrial or district heating systems, industrial process heat and steam and occasionally as the driving force for cooling and air conditioning systems. Electricity is often supplied to national distribution grids and/or used within the installation.

2.4.2 External factors affecting energy efficiency

2.4.2.1 Waste type and nature

The characteristics of the waste delivered to the installation will determine the techniques that are appropriate and the degree to which energy can be effectively recovered.

The chemical and physical characteristics of the waste actually arriving at plants or fed to the incinerator can be influenced by many local factors including:

- contracts with waste suppliers (e.g. industrial waste added to MSW);
- on-site or off-site waste treatments or collection/separation regimes;
- market factors that divert certain streams to or from other forms of waste treatment.

In some cases the operator will have very limited scope to influence the characteristics of the waste supplied; in other cases this is considerable.

Table 2.10 gives typical net calorific value ranges for some waste types.

Table 2.10: Ranges and typical net calorific values for some incinerator input wastes

Input type	Comments and examples	LHV in original substance (humidity included)	
		Range (GJ/t)	Average (GJ/t)
Mixed municipal solid waste (MSW)	Mixed household domestic wastes	6.3–10.5	9
Bulky waste	Furniture, etc. delivered to MSWIs	10.5–16.8	13
Waste similar to MSW	Waste of a similar nature to household waste but arising from shops, offices, etc.	7.6–12.6	11
Residual MSW after recycling operations	Screened-out fractions from composting and material recovery processes	6.3–11.5	10
Commercial waste	Separately collected fractions from shops and offices, etc.	10–15	12.5
Packaging waste	Separately collected packaging	17–25	20
RDF (refuse-derived fuels)	Pellet or floc material produced from municipal and similar non-hazardous waste	11–26	18
Product-specific industrial waste	e.g. plastic or paper industry residues	18 – 23	20
Hazardous waste	Also called chemical or special wastes	0.5–20	9.75
Sewage sludges	Arising from waste water treatment works	See below	See below
	Raw (dewatered to 25 % dry solids)	1.7–2.5	2.1
	Digested (dewatered to 25 % dry solids)	0.5–1.2	0.8

Source: [31, Energy subgroup 2003]

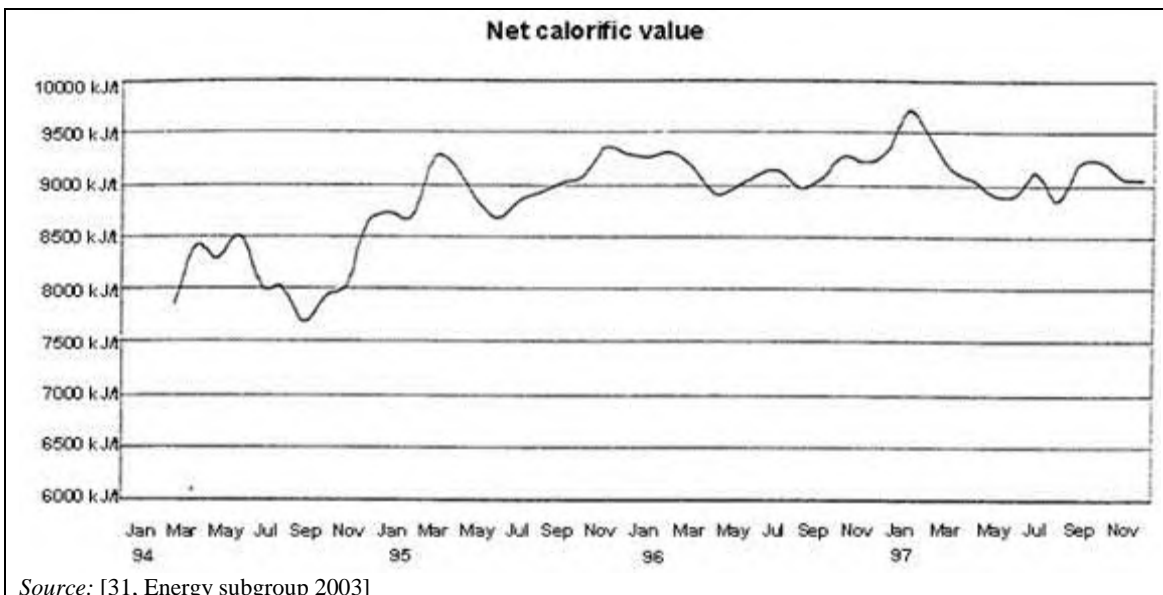

Source: [31, Energy subgroup 2003]

Figure 2.28: Graph showing recorded variation in waste LHV at a MSWI over 4 years

2.4.2.2 Influence of plant location on energy recovery

In addition to waste quality and technical aspects, the possible efficiency of a waste incineration process is influenced to a large extent by the output options for the energy produced. Processes with the option to supply electricity, steam or heat will be able to use more of the heat generated during the incineration for this purpose and will not be required to cool away the heat, which otherwise results in reductions in efficiency.

The highest waste energy utilisation efficiency can usually be obtained where the heat recovered from the incineration process can be supplied continuously as district heat, process steam, etc., or in combination with electricity generation. However, the adoption of such systems is very dependent on plant location, in particular the availability of a reliable user for the supplied energy. The generation of electricity alone (i.e. no heat supply) is common and generally provides a means of recovering energy from the waste that is less dependent on local circumstances.

Where there is no external demand for the energy, a proportion is often used on site to supply the incineration process itself and thus to reduce the quantity of imported energy to very low levels. For municipal waste incineration plants, such internal use may be in the order of 10 % of the energy of the waste incinerated.

Cooling systems are employed to condense boiler water for return to the boiler.

Processes that are conveniently located for connection to energy distribution networks (or individual synergistic energy users) increase the possibility that the incineration plant will achieve higher overall efficiencies.

2.4.2.3 Factors taken into account when selecting the design of the energy cycle

The following factors are reported to be taken into account when determining the local design of a new waste incineration plant [51, CNIM 2003].

Table 2.11: Factors taken into account when selecting the design of the energy cycle for waste incineration plants

Factor to consider	Detailed aspects to consider
Waste feed	<ul style="list-style-type: none"> Quantity and quality Availability, regularity, delivery variation with seasons Prospect of change in both the nature and the quantity of waste Effects of waste separation and recycling.
Energy sales possibilities	<p>Heat</p> <ul style="list-style-type: none"> To communities, e.g. district heating To private industries Heat use, e.g. process use, heating use Geographical constraints; delivery piping feasibility Duration of the demand, duration of the supply contract Obligations on the availability of the supply, i.e. is there another source of heat when the incinerator is shut down? Steam/Hot water conditions: pressure (normal/minimum), temperature, flow rate, condensate return or not? Season demand curve Subsidies can influence economics significantly Heat customer holdings in the plant financing, i.e. security of supply contract. <p>Electricity</p> <ul style="list-style-type: none"> National grid or industrial network (rare), plant self-consumption, customer self-consumption (i.e. in a sewage sludge treatment plant) Price of electricity significantly influences investment Subsidies or loans at reduced rates can increase investment Technical requirements: voltage, power, availability of distribution network connection.
Local conditions	<ul style="list-style-type: none"> Cooling medium selected: air or water Meteorological conditions in time: temperature, hygrometry, (min., average, max., curves) Acceptability of a 'plume' of water vapour (cooling tower) Availability of cold water source: river or sea <ul style="list-style-type: none"> - Temperature, quality of water - Flow rate which can be pumped according to the season - Permitted temperature increase.
Combined heat and power	<ul style="list-style-type: none"> Apportionment according to the season Evolution of the apportionment in future.
Other	<ul style="list-style-type: none"> Choice between: increasing energy output, reducing investment cost, operational complexity, availability requirements, etc. Acceptable noise level (air coolers) Available space Architectural constraints.
<i>Source: [51, CNIM 2003]</i>	

2.4.3 Energy efficiency of waste incinerators

[29, Energy subgroup 2002]

In order to enable a comparison of energy performance between waste incinerators, it is necessary to standardise:

- assessment boundaries, i.e. what parts of the process are included/excluded;
- calculation methods;
- how to deal with different energy inputs and outputs, e.g. heat, steam, non-waste fuels, electricity production, and internal usage of electricity and steam.

The sections that follow describe the typical inputs and outputs seen at many waste incinerators.

2.4.3.1 Energy inputs to waste incinerators

[29, Energy subgroup 2002]

In addition to the energy in the waste, there are other inputs to the incinerator that need to be recognised when considering the energy efficiency of the plant as a whole.

Electricity inputs

Electricity is needed to run the process. The source can be external or circulated.

Steam/heat/hot water inputs

Steam (or hot water or other heat carrier) can be used in the process. The source can be external or circulated.

Non-waste fuels

Non-waste fuels are used to:

- i. preheat the combustion air;
- ii. increase the temperature in the combustion chamber to the required level during start-up before the plant is fed with waste;
- iii. ensure that the required combustion chamber temperatures are maintained during plant operation;
- iv. maintain the temperature in the combustion chamber at the required level during shutdown, while there is still unburned waste in the plant;
- v. heat up the flue-gas for treatment in specific devices, such as SCR or bag filters;
- vi. heat up the flue-gas (e.g. after wet scrubbers) in order to avoid bag filter and stack corrosion, and to suppress plume visibility.

When considering the overall efficiency of energy recovery from the waste, it is important to note that some of these non-waste fuel uses can contribute to steam production whereas others, such as v. and vi. above, may not contribute because they are adding heat after the boiler. This needs to be taken into account when calculating energy efficiency figures.

At waste gasification plants, non-waste fuels such as coal or coke may be added to the waste in order to produce a syngas with a desired chemical composition and calorific value.

2.4.3.2 Energy outputs from waste incinerators

Electricity

The electricity produced is easily measured. The incineration process itself may use some of the produced electricity.

Fuels

Fuel (e.g. syngas) is produced in gasification/pyrolysis plants and may be exported or combusted on site.

Steam/hot water

The heat released in the combustion of waste is often recovered for a beneficial purpose, e.g. to provide steam or hot water for industrial or domestic users, or even as a driving force for cooling systems.

Combined heat and power (CHP) plants provide both heat and electricity.

2.4.4 Applied processes for improving energy recovery

2.4.4.1 Waste feed pre-treatment

There are two main categories of pre-treatment techniques of relevance to energy recovery:

- homogenisation;
- extraction/separation.

Homogenisation of waste feedstock involves mixing, and sometimes shredding, the wastes received at the plant in order to supply a feed with consistent combustion qualities.

The main benefits achieved are the improved process stability and more consistent steam quality which can allow for increased electricity generation. The overall energy efficiency benefits are thought to be limited but cost savings and other operational benefits may arise.

Extraction/separation involves the removal of certain fractions from the waste before it is sent to the combustion chamber.

Techniques range from extensive physical processes for the production of refuse-derived fuels (RDF) and the blending of liquid wastes to meet specific quality criteria to the simple spotting and removal by crane operators of large items that are not suitable for combustion, such as concrete blocks or large metal objects. The main benefits achieved are:

- increased homogeneity, particularly where more elaborate pre-treatments are used (see comments above for homogeneity benefits);
- removal of bulky items – thus reducing the risks of obstruction and unscheduled shutdowns;
- possible use of fluidised beds or other techniques that could improve combustion efficiency.

Extraction, separation and homogenisation of the waste may significantly improve the energy efficiency of the incineration plant itself. This is because these processes can substantially change the nature of the waste that is finally delivered to the incineration process, which can then allow the incineration process to be designed around a narrower input specification, and lead to optimised (but less flexible) performance. However, for a wider assessment (beyond the scope of this document), it is important to note that the techniques that are used in the preparation of this different fuel themselves require energy and will result in additional emissions.

2.4.4.2 Boilers and heat transfer

Tubular water boilers are generally used for steam and hot water generation from the energy potential of hot flue-gases. The steam or hot water is generally produced in tube bundles in the flue-gas path. The envelopment of the furnace, the following empty passes and the space where evaporator and superheater tube bundles are located are generally designed with water-cooled membrane walls.

In steam generation, it is usually possible to differentiate between the three heat surface areas shown in Figure 2.29.

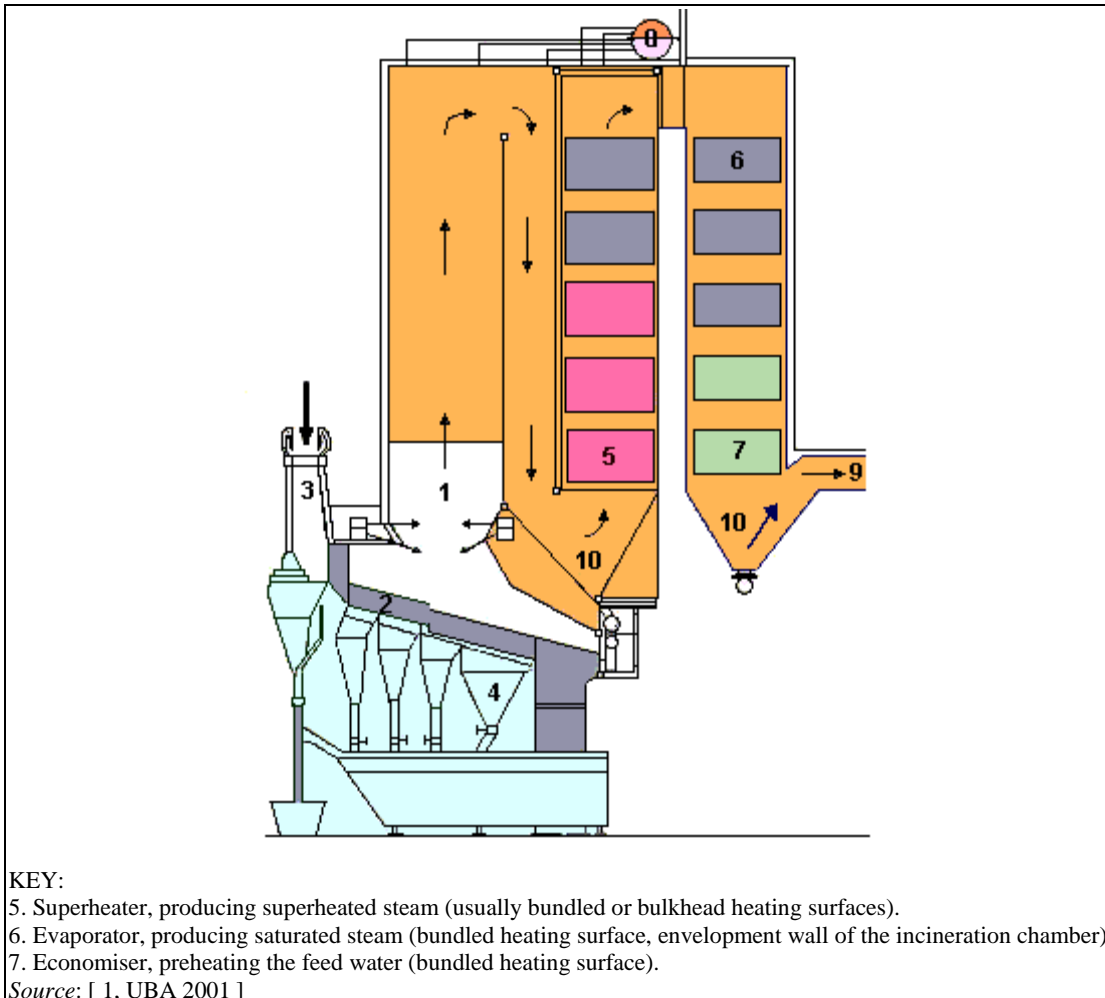

Figure 2.29: Illustration of individual heat surface areas in a steam generator

The following traditional evaporation systems can be differentiated (see Figure 2.30):

- **Natural circulation:** The water/steam mass flow in the evaporator is maintained due to the different density of the medium in heated and unheated pipes. The water/steam mixture flows into a steam separator drum and the saturated steam then passes through a superheater.
- **Forced circulation:** This is similar to natural circulation, but a circulation pump is used to increase circulation in the evaporator.
- **Forced continuous flow (once-through boiler):** In this system, the feed water is pumped in a continuous flow through the economiser, the evaporator and the superheater.

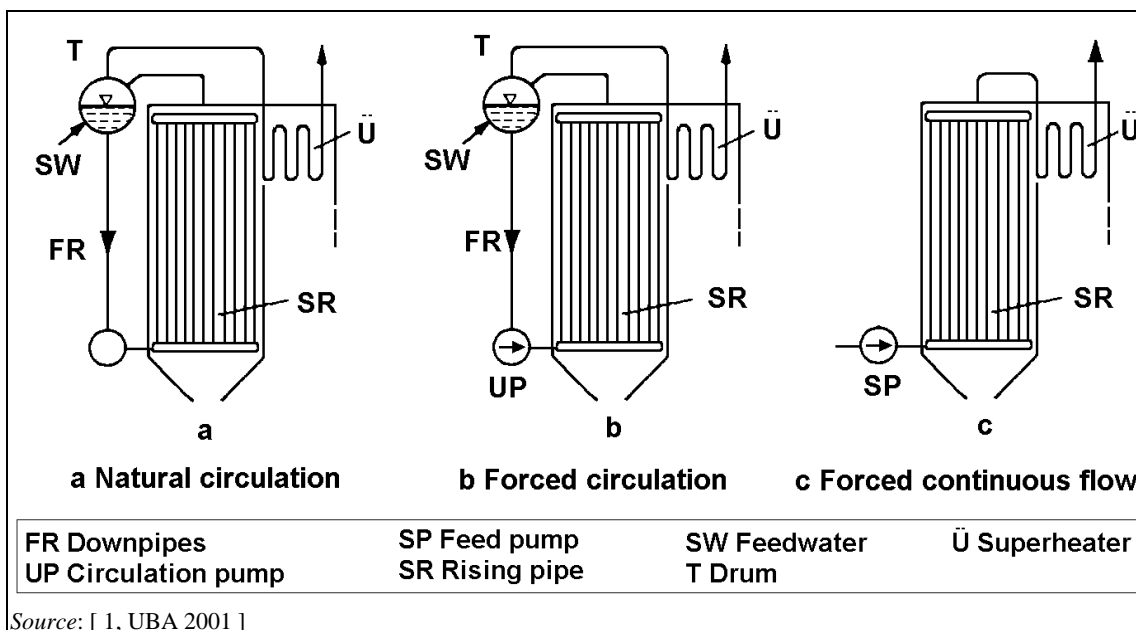

Figure 2.30: Basic boiler flow systems

Spray coolers and surface coolers are used in circulation boilers in order to maintain the exact required steam temperature. Their function is to balance the fluctuations of the steam temperature, caused by changes in load, waste quality and excess air, as well as contamination of the heat-exchange surfaces.

The preparation of boiler feed water and make-up water is essential for effective operation and to reduce corrosion inside the tubes and the risk of turbine damage. The quality of boiler water must be higher when increased steam parameters are used.

A compromise is required when determining steam parameters of waste-fired boilers. The selection of high steam temperatures and pressures will enable a better utilisation of the energy contained in the waste when the plant design is mainly oriented towards electricity production, but can lead to significantly increased corrosion problems, especially on the superheater surfaces and in the evaporator. In municipal waste incinerators, it is common to operate at steam parameters of 40 bar and 400 °C when electricity is produced, although higher values are used, especially with pretreated MSW and prepared RDF (values of 60 bar and 520 °C are used when combined with special measures to prevent corrosion). In the case of heat production, steam with lower parameters or superheated water may be produced. As these steam parameters are relatively low compared to those typical of primary fuel-fired power plants, incinerators almost exclusively use natural circulation steam boilers. This avoids the risk, in the event of a feed water pump malfunction, of a sudden interruption of the heat transfer while waste is being incinerated.

An important feature of waste incineration is the high dust load in flue-gases. Gravity separation of dust can be enhanced by designing boiler areas with low flue-gas speeds and bends in the gas flow path.

The high dust load in the flue-gases causes dust deposition on the heat transfer surfaces, reducing heat transfer and overall plant performance. Thus, heat transfer surface cleaning plays an important role. This cleaning can be accomplished manually or automatically with lances (compressed air or water jet), agitators, soot blowers using steam, a hail of pellets (sometimes shot cleaning), sound and shock waves, or with tank cleaning devices. The resulting solid residue is extracted at the bottom of the boiler as boiler ash.

Different boiler concepts can be used in waste incineration plants. They are from left to right (see Figure 2.31):

- horizontal boilers;
- combination of vertical and horizontal boilers;
- vertical boilers.

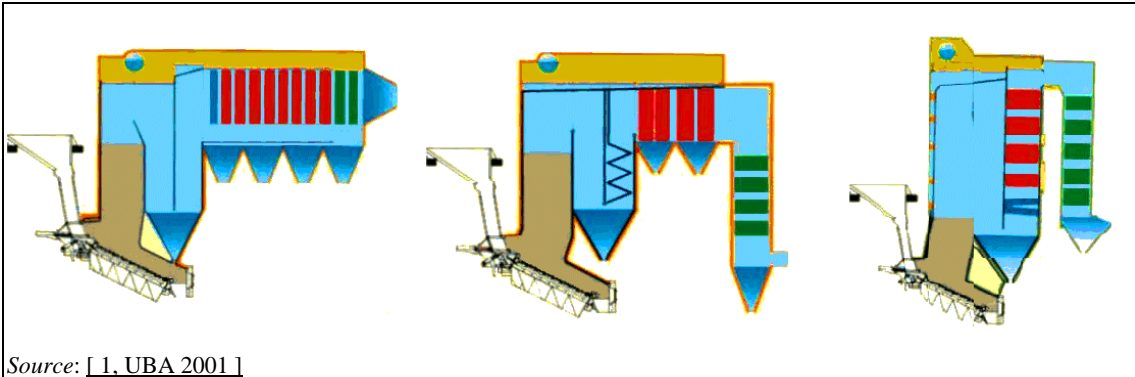

Figure 2.31: Overview of various boiler systems: horizontal, combination and vertical

In horizontal and vertical systems, usually a number of empty passes with evaporation walls are followed by an arrangement of bundles of heat transfer surfaces, i.e. superheater, evaporator and economiser. The selection of the system to be deployed depends on the given building concept, the selected steam parameters, and the customer specifications.

2.4.4.2.1 Corrosion in boilers

[1, UBA 2001]

Corrosion is caused by the chemical attack of flue-gas and ash particles from the furnace. The incineration chamber, the water walls of the first blank (empty) passes, and the superheater are the boiler components that are most in danger of corrosion.

Erosion, which is the abrasion of surface material through wear and tear, is caused primarily by the ash particles present in flue-gas. Erosion appears mostly in the area of gas redirection.

Tube wear is caused by a combination of corrosion and abrasion. Corrosion appears on clean metallic surfaces. If the corrosion products deposit themselves as film on the pipe surface (oxide layer), they function as a protective layer and slow down corrosion. If this protective layer wears out through erosion, and if the metallic surface reappears, the entire process starts anew.

The comprehensive consideration of the corrosion processes is difficult, as this involves the interaction of the physical, chemical, metallurgical and crystallographic parameters of the incineration process.

Various types of flue-gas corrosion exist:

- Tinder process: High-temperature corrosion.
- Initial corrosion: Time-limited ferrous chloride formation before the formation of the first oxide layer on 'blank' steel during start-up. This reaction occurs continuously after film removal through erosion.

- **Oxygen-deficiency corrosion:** Through FeCl_2 formation under a deoxygenated flue-gas atmosphere, e.g. under films (such as oxides, contamination or fireproof material) and in the furnace area. FeCl_2 is sufficiently volatile at the temperatures used in WI and is therefore mobilised. An indicator for such corrosion is the appearance of CO (this explains the often wrongly-used term CO corrosion). The microscopic situation at the border between material and film is, however, decisive. This corrosion is observed in individual cases with steam pressures above 30 bar, but more usually above 40 bar. The corrosion rate increases with the metal temperature. The corrosion products appear in flaky layers.
- **High-temperature chloride corrosion:** Corrosion by chloride, which is released during the sulphating of alkaline chlorides and attacks iron or lead hydroxides. This corrosion mechanism is observed in waste incineration plants with flue-gas temperatures $> 700\text{ }^\circ\text{C}$ and at pipe wall temperatures above $400\text{ }^\circ\text{C}$. The corrosion products can be recognised as a black firmly bonded cup that includes a hygroscopic red FeCl_3 layer in thicker films.
- **Molten salt corrosion:** The flue-gas contains alkali and similar components, which can form eutectic compounds that have a lower melting point than the original individual components. These molten systems are highly reactive and can cause severe corrosion of steel. They can react with the refractory lining and lead to the internal formation of compounds like kalsilite, leucite and sanidine which destroy the refractory mechanically. They can also form low viscous melts on the surface consisting of deposited material and refractory material (refractory corrosion).
[64, TWG 2003], [74, TWG 2004]
- **Electrochemical corrosion:** This is based on the electrical potential equalisation of different metals. The conductor can be aqueous or a solid that shows sufficient electrical conductivity at the temperatures seen. The conductivity can arise from the water dew point, from the sulphuric acid dew point, or from molten salts.
- **Standstill corrosion:** Due to their high chloride content (especially CaCl_2), the deposits are hygroscopic. The humidity in the air dissolves these compounds and causes the appearance of chemical dissolution in the material.
- **Dew point corrosion:** When the temperature falls below the acid dew point, wet chemical corrosion appears on cold surfaces. This damage can be avoided by raising the temperature or by selecting an appropriate material.

In reality, from a thermodynamic perspective, a degree of corrosion is unavoidable. Countermeasures only help to reduce corrosion damage to an acceptable level. The causes of corrosion require constructive and operational countermeasures. Improvement possibilities are mainly found in the steam generator. Low steam parameters, long reaction times before the flue-gas comes into contact with the heat surfaces, lowering the flue-gas velocity, and levelling of the speed profile could all be successful. Protective shells, tooling, stamping, and deflectors can also be used to safeguard heat surfaces.

A compromise must be found in determining the boiler cleaning intensity between the best possible heat transfer (metallic pipe surface) and optimal corrosion protection.

2.4.4.3 Combustion air preheating

Preheating the combustion air is particularly beneficial for assisting the combustion of high-moisture-content wastes. The pre-warmed air supply dries the waste, thus facilitating its ignition. The supply heat can be taken from the combustion of the waste by means of heat-exchange systems.

Preheating of primary combustion air can have a positive influence on overall energy efficiency in the case of electricity production.

2.4.4.4 Water-cooled grates

Water cooling of grates is used to protect the grate. Water is used as a cooling medium to capture heat from the burning waste bed and use it elsewhere in the process. It is common that the heat removed is fed back into the process for preheating the combustion air (primary and/or secondary air) or heating the condensate. Another option is to directly integrate the water cooling into the boiler circuit, operating it as an evaporator.

These grates are applied where the net calorific value of the waste is higher, typically above 10 MJ/kg. Increases in the calorific value of municipal waste seen in Europe have increased the application of this technique.

There are other reasons for the use of water-cooled grates – these are discussed in Section 2.3.1.2.

2.4.4.5 Flue-gas condensation

[5, RVF 2002]

Water in the flue-gas comprises evaporated free water from the fuel and reaction water from the oxidation of hydrogen, as well as water vapour in the combustion air. When burning wastes, the water content in the flue-gas after the boiler and economiser normally varies between 10 vol-% and 20 vol-%, corresponding to water dew points of about 50–60 °C. During the cleaning of the boiler with steam the water content in the flue-gas increases to about 25 %.

The minimum possible dry gas temperature at this point is 130–140 °C using normal boiler construction materials. This temperature is mostly determined by the need to be above the acid dew point, which is linked to the SO₃ and water content in the flue-gas.

Lower temperatures result in corrosion. The boiler thermal efficiency (steam or hot water from waste) will, under these conditions, be about 85 %, as calculated based on the calorific value of the waste input. However, if there is more available energy in the flue-gas, a water vapour will result which has a latent specific energy of about 2 500 kJ/kg and dry gas with a specific heat of about 1 kJ/(kg °C).

Return water from district heating at a temperature of 40–70 °C (system configuration-dependent) can be used directly to cool and condense the water vapour in the flue-gas. This system is common at plants burning biofuel, which is normally very wet and gives water dew points of 60–70 °C in the flue-gas.

Condensation can be effective only if there is a comparatively big temperature difference between the water dew point in the flue-gas and the cooling water (normally district heating return water). If this condition is not fulfilled, heat pumps can be installed (see Section 2.4.4.6).

It should be noted that, in this case, it is the cold district heating water return that provides the energetic driver for the condensation of the flue-gases. This situation is only likely to exist in regions with the lower ambient temperatures found mostly in northern Europe.

2.4.4.6 Heat pumps

[5, RVF 2002]

The main purpose of heat pumps is to transform energy from one temperature level to a higher level. There are three different types of heat pumps in operation at incineration installations. These are described below with examples.

2.4.4.6.1 Compressor-driven heat pumps

This is the most well-known heat pump. It is, for instance, installed in refrigerators, air conditioners, chillers, dehumidifiers, ground source heat pumps and air source heat pumps. An electrical motor normally drives the pump, but for big installations steam turbine-driven compressors can be used.

In a closed circuit, a refrigerant substance (e.g. R134a) is circulated through a condenser, expander, evaporator and compressor. The compressor compresses the substance, which condenses at a higher temperature and delivers the heat to the district heating water. There the substance is forced to expand to a low pressure, causing it to evaporate and absorb heat from the water from the flue-gas condenser at a lower temperature. Thus the energy at a low temperature in the water from the flue-gas condenser has been transformed to the district heating system at a higher temperature. In typical incineration conditions, the ratio between output heat and compressor power (heat to power ratio) can be as high as 5. The compressor-driven heat pump can utilise a very high proportion of the energy of the flue-gas.

2.4.4.6.2 Absorption heat pumps

Similar to the compressor-type pump, absorption heat pumps were originally developed for cooling. Commercial heat pumps operate with water in a closed loop through a generator, condenser, evaporator and absorber. Instead of compression, the circulation is maintained by water absorption in a salt solution, normally lithium bromide, in the absorber. The diluted water/salt solution is pumped to the generator. There the water is evaporated by hot water or low-pressure steam and is then condensed in the condenser at a higher temperature. The heat is transferred to the district heating water. The concentrated salt solution is circulated back to the absorber. The process is controlled by the pressure in the system, in relation to the vapour pressure of the liquids, water and lithium bromide.

Electrical power consumption is very low, limited to a small pump between the absorber and generator, and there are few moving parts. The ratio between the output heat and absorber power is normally about 1.6.

2.4.4.6.3 Open heat pumps

The principle of an open heat pump is to decrease the water content of the flue-gas downstream of the condenser using a heat and humidity exchanger with air as the intermediate medium.

The higher water content in the flue-gas in the condenser means a higher water dew point, and a bigger difference between the water dew point and the dew point of the return water from the district heating system.

2.4.4.6.4 Example data of different heat pumps

The following table has been collated from data from three different plants in Sweden, each using a different type of heat pump, as described above.

As can be seen from the table, the use of heat pumps consumes electricity; therefore the net electrical output is reduced. However, the thermal heat output is increased.

Table 2.12: Example data showing the variation in heat and electricity output at three different plants in Sweden when using various different types of heat pumps

	Example 1	Example 2	Example 3
Heat pump type	Compressor-driven	Absorption heat pump	Open heat pumps
Net heat output using heat pump	82	80	81
Net heat output without heat pump	60	63	70
Variation in heat output	+37 %	+28 %	+16 %
Net electricity output using heat pump	15	15	0
Net electricity output without heat pump	20	19	0
Variation of electricity production	-25 %	-21 %	0
NB: Data refer to an energy input of 100, therefore all numbers are percentages. Example 3 does not produce electricity.			
<i>Source: [5, RVF 2002]</i>			

2.4.4.7 Flue-gas recirculation

A proportion (approximately 10–20 vol-%) of the (usually cleaned) flue-gases is recirculated, normally after pre-dedusting, to replace secondary air feeds in the combustion chamber.

This technique is reported to reduce heat losses with the flue-gas and to increase the process energy efficiency by around 0.75–2 %. Additional benefits of primary NO_x reduction are also reported.

Lagging of the recirculation ducting is reported to provide an effective remedy for corrosion concerns in this area.

2.4.4.8 Recovery of the heat used for reheating flue-gases to the operating temperature of FGC devices

Some air pollution control equipment requires the flue-gases to be reheated to enable their effective operation. Examples include tail-end SCR systems and bag filters that generally require temperatures in the region of 200–250 °C and 140–190 °C, respectively.

The energy for heating the gases can be obtained from:

- external energy sources (e.g. electrical heating, gas or oil burners);
- use of process-generated heat or power (e.g. steam bleeds from the turbine).

The use of heat exchangers to recapture the heat after the equipment reduces the need for external energy input. This is carried out where the next stage of the process does not require the flue-gas temperature to be as high as the exit temperature of the preceding equipment.

2.4.4.9 Steam-water cycle improvements: effect on efficiency and other aspects

The selection of the steam-water cycle will generally have a much greater impact on the energy efficiency of the installation than improving individual elements of the system, and therefore provides the greatest opportunity for increased use of the energy in the waste.

The following table provides examples of techniques used for improving energy recovery at a municipal waste-to-energy plant, along with an estimation of their effectiveness, advantages and disadvantages. The figures given were calculated for one example plant that only generated electricity [50, CNIM 2003].

Table 2.13: Steam-water cycle improvements: effect on efficiency and other aspects

Technique	Net power output increase (approx.) and other advantages	Disadvantages
Increase steam pressure	3 % for 60 bar instead of 40 bar	I. Increase in investment cost II. Corrosion risk slightly increased
Decrease vacuum at turbine outlet (e.g. a hydro-condenser may be used to improve vacuum)	1–2 % for 20 mbar reduction	III. Significant increase in investment cost (air condenser area: + 10 % between 120 mbar and 110 mbar at an air temperature of 15 °C) IV. Size and noise increase V. Uncertainties on suppliers' commitments for very low pressure
Heat secondary air	0.7–1.2 %	VI. Complexity and cost increase if there are 2 air fans
Air heater in 2 stages (i.e. 2 bleeds on the turbine)	1–1.5 %	VII. Cost increase VIII. Space requirement increase
Add a condensate heater	0.5–1.2 %	IX. Cost of the equipment and piping X. Not necessarily applicable for small TG sets XI. Corrosion problem may occur in particular during transitory phases (start-up, shutdown, etc.)
Recycle a part of the flue-gas	0.75–2 % for a decrease of 1 % of dry O ₂ ----- Decrease of NO _x level by approx. 100 mg/Nm ³	XII. Increase in investment cost XIII. Decreasing the O ₂ by other means reduces the interest of flue-gas recycling XIV. Corrosion problem may occur in particular during transitory phases (start-up, shutdown, etc.)
Reduce the flue-gas temperature at boiler outlet	0.4–0.7 % for 10 °C lower between 190 °C and 140 °C	XV. The boiler outlet temperature is determined according to the FGC system type
Use SNCR de-NO _x instead of SCR	3–6 % depending on the processes used	XVI. See discussions about SCR and SNCR de-NO _x
Optimise the choice of the TG set	1 to 2 % instantaneous, but much higher difference over a long period of time if low availability	XVII. Some TG sets have higher efficiency at nominal conditions but lower reliability, availability and/or flexibility at partial load
Reduce O ₂ content in flue-gas by 1 % (in range 6–10 %)	1–2 % increase	XVIII. With a lower O ₂ content, CO may increase XIX. Low oxygen content may increase corrosion risk

Source: [50, CNIM 2003]

2.5 Applied flue-gas cleaning and control systems

2.5.1 Summary of the application of FGC techniques

Flue-gas cleaning systems are constructed from a combination of individual process units that together provide an overall treatment system for the flue-gases. The balance of applied systems is different with different waste streams. A description of the individual process units, organised according to the substances upon which they have their primary effect, is given in this chapter.

Some flue-gas cleaning techniques are also explained in detail in the Best Available Techniques Reference Document for Common Waste Water and Waste Gas Treatment/Management Systems in the Chemical Sector (the CWW BREF), published in July 2016.

Table 2.14 below gives a summary of the application of some systems in the waste incineration sector, based on the reference lines participating in the 2016 data collection. [81, TWG 2016]

Table 2.14: Summary of the main FGC systems applied in the WI reference lines that participated in the 2016 data collection

Country	Number of WI lines with various flue-gas cleaning systems											
	Acid reduction						Dust reduction			NO _x reduction		
	DSI	Semi-WS	WS	DSI and WS	Semi-WS and WS	DSI and Semi-WS	ESP	ESP and BF	BF	SNCR	SNCR and SCR	SCR
Austria	1	1	5	7	0	0	4	1	9	0	0	14
Belgium	1	0	4	6	1	4	7	8	2	10	0	8
Czech Republic	0	0	0	0	0	2	0	0	2	2	0	0
Denmark	2	0	1	4	0	0	0	3	3	7	0	0
Finland	3	0	0	4	0	1	0	3	5	7	0	1
France	30	2	18	8	4	8	19	17	38	33	0	30
Germany	22	5	39	32	0	11	39	25	46	43	3	53
Hungary	0	2	0	0	0	0	0	0	2	2	0	0
Italy	26	0	2	5	0	0	0	13	20	9	13	11
Netherlands	1	0	2	3	0	0	1	3	2	2	0	4
Norway	0	0	0	6	0	0	2	1	3	5	0	1
Poland	7	0	1	1	0	0	1	2	4	5	3	0
Portugal	0	0	0	0	0	7	0	0	7	7	0	0
Spain	4	1	1	0	0	12	1	1	16	8	0	10
Sweden	1	0	2	4	0	0	2	0	5	5	0	1
UK	14	2	4	6	0	3	1	4	24	25	0	0
Total lines	112	12	79	86	5	49	77	81	188	170	19	133
NB: DSI = dry sorbent injection; Semi-WS = semi-wet scrubber; WS = wet scrubber; BF = bag filter. 2. Other combinations of FGC unit operations are applied but not included in the table. Source: [81, TWG 2016]												

2.5.2 Overview of overall combined FGC system options

The individual components of a FGC system are combined to provide an effective overall system for the treatment of the pollutants that are found in the flue-gases. There are many individual components and designs, and they may be combined in many ways. The diagram below shows an example of the options and their possible combination. It can be seen that in this assessment there are a total of 408 different combined systems.

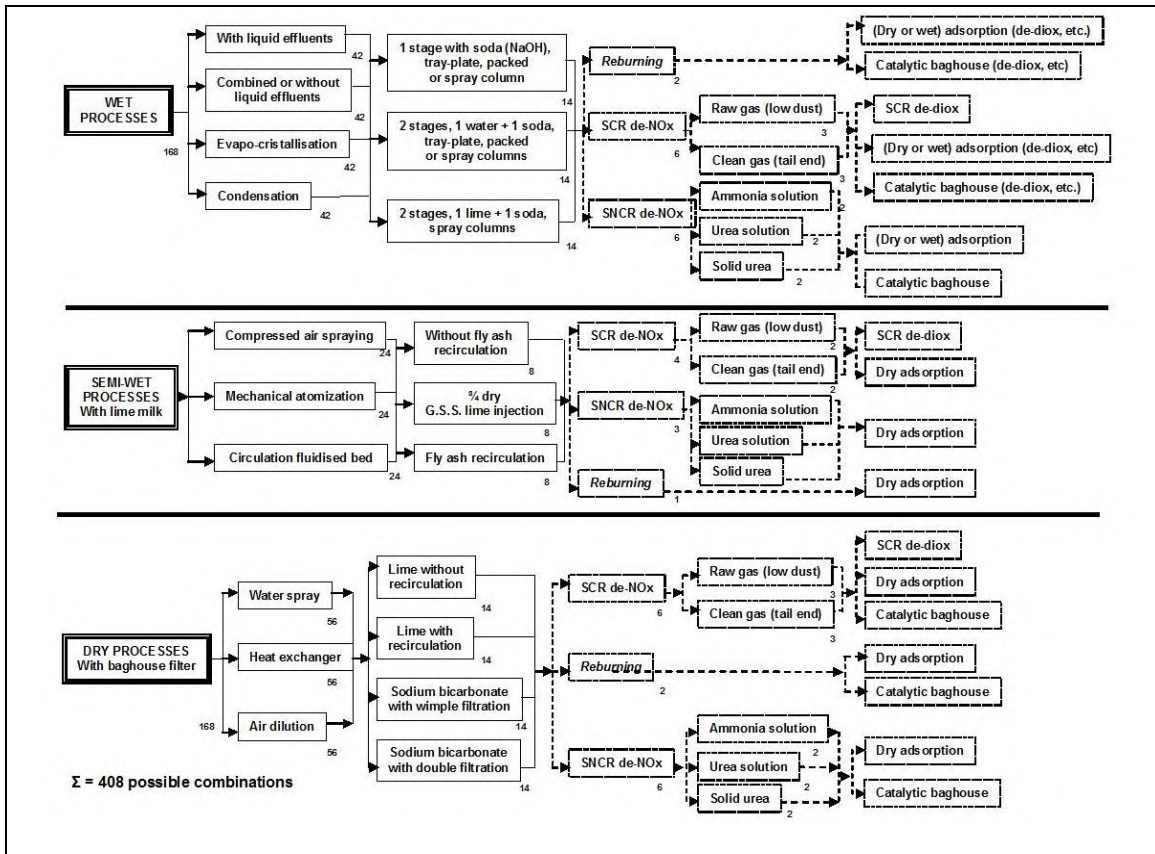

Figure 2.32: Overview of potential combinations of FGC systems

2.5.3 Techniques for the reduction of dust emissions

[1, UBA 2001] The selection of gas cleaning equipment for dust from the flue-gas is mainly determined by:

- dust load in the gas stream;
- average particle size;
- particle size distribution;
- flow rate of gas;
- flue-gas temperature;
- compatibility with other components of the entire FGC system (i.e. overall optimisation);
- required outlet concentrations.

Some parameters are rarely known (such as particle size distribution or average size) and are empirical figures. Available treatment or disposal options for the deposited substances may also influence FGC system selection, i.e. if an outlet exists for treatment and use of fly ash, this may be collected separately rather than being collected with FGC residues.

[74, TWG 2004]

2.5.3.1 Electrostatic precipitators

[1, UBA 2001]

Electrostatic precipitators are sometimes also called electrostatic filters. The efficiency of dust removal of electrostatic precipitators is mostly influenced by the electrical resistivity of the dust. If the dust layer resistivity rises to values above approximately 10^{11} to 10^{12} Ωcm , removal efficiencies are reduced. The dust layer resistivity is influenced by waste composition. Thus it may change rapidly with a changing waste composition, particularly in hazardous waste incineration. Sulphur in the waste (and water content at operating temperatures below 200 °C [64, TWG 2003]) often reduces the dust layer resistivity through the generation of SO_2 (SO_3) in the flue-gas, and therefore facilitates deposition in the electric field.

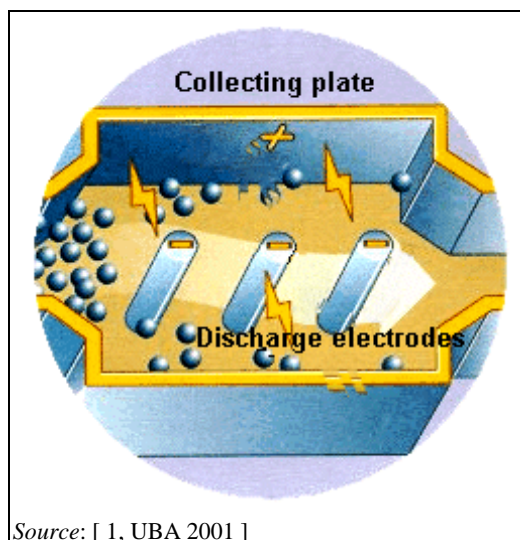

Figure 2.33: Operating principle of an electrostatic precipitator

For the deposition of fine dust and aerosols, installations that maintain the effect of the electric field by drop formation in the flue-gas (pre-installed condensation and wet electrostatic precipitators, condensation electrostatic precipitators, electrodynamic venturi scrubbers, ionised spray coolers) can improve removal efficiency.

Typical operational temperatures for electrostatic precipitators are 160 – 260 °C. Operation at higher temperatures (e.g. above 250 °C) is generally avoided as this may increase the risk of PCDD/F formation.

2.5.3.2 Wet electrostatic precipitators

Wet electrostatic precipitators are based upon the same technological working principle as electrostatic precipitators. With this design, however, the precipitated dust on the collector plates is washed off using a liquid, usually water. This may be done continuously or periodically. This technique operates satisfactorily in cases where moist or cooler flue-gas enters the electrostatic precipitator. [1, UBA 2001]

2.5.3.3 Condensation electrostatic precipitators

The condensation electrostatic precipitator is used to deposit very fine, solid, liquid, or sticky particles, for example in the flue-gas from hazardous waste incineration plants. Unlike conventional wet electrostatic precipitators, the collecting surfaces of condensation electrostatic precipitators consist of vertical plastic tubes arranged in bundles, which are externally water-cooled. [1, UBA 2001]

The dust-containing flue-gas is first cooled down to dew-point temperature in a quench by direct injection of water and then saturated with vapour. By cooling the gases in the collecting pipes further down, a thin, smooth liquid layer forms on the inner surface of the tubes as a result of condensation of the vapour. This is electrically earthed and thus serves as the passive electrode.

Particles are deposited by the influence of the electric field between the discharge electrodes suspended in the tube axes and the condensation layer in continuous flow. At the same time the condensation layer also causes continuous removal of deposited particles from the deposition area. Even water-insoluble dust and poorly wettable soot are washed off. The constantly renewed wetting prevents dry spots and sticking, which can cause sparking (electrical discharges between the electrodes). Avoiding sparking allows for a higher deposition voltage, which in turn leads to an improved and consistently high deposition performance (see Figure 2.34).

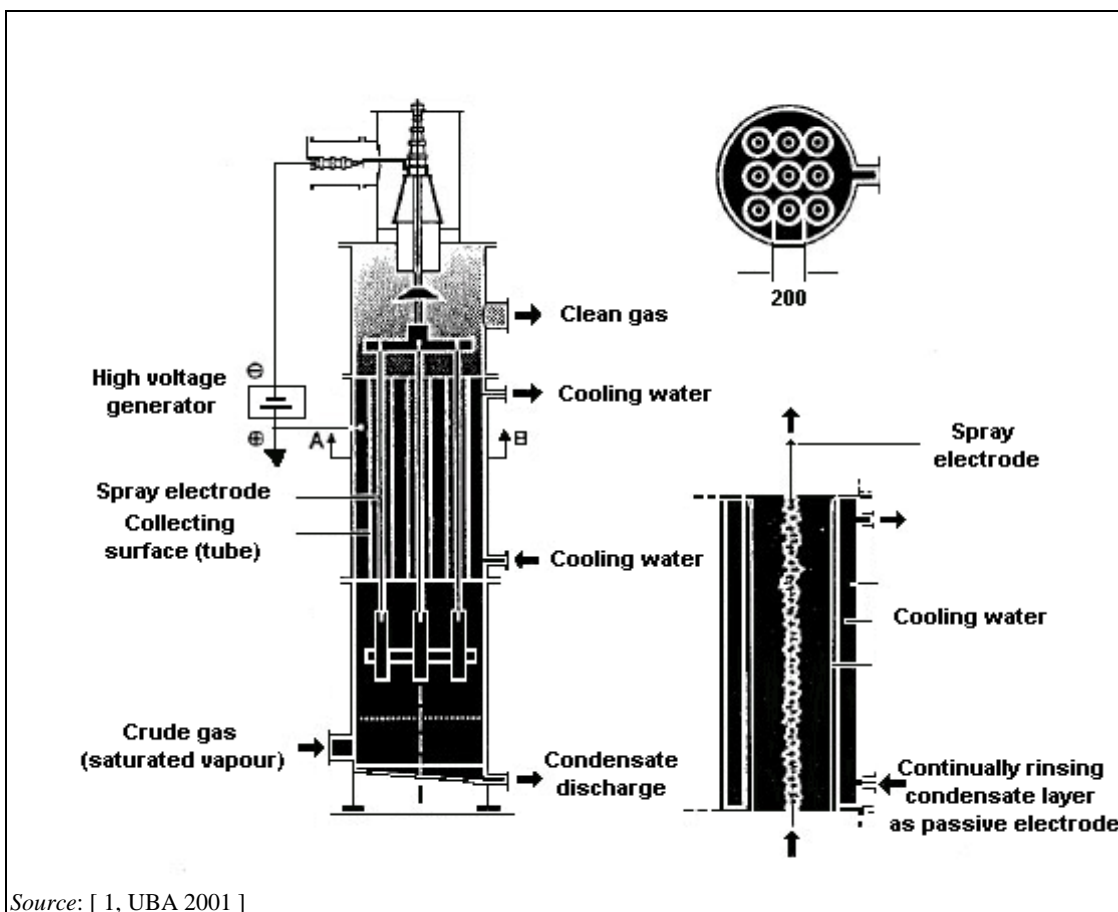

Source: [1, UBA 2001]

Figure 2.34: Condensation electrostatic precipitator

2.5.3.4 Ionisation wet scrubbers

The purpose of the ionisation wet scrubber (IWS) is to remove various pollutants from the flue-gas flow [1, UBA 2001]. The IWS combines the principles of:

- electrostatic charging of particles, electrostatic attraction and deposition of aerosols (smaller than 5 μm);
- vertical deposition of coarse, liquid and solid particles (larger than 5 μm); and
- absorption of hazardous, corrosive and odorous gases.

The IWS system is a combination of an electrostatic filter and a packed scrubber. It is reported to require little energy and has a high deposition efficiency for particles in the submicron as well as the micron range.

A high-voltage zone is installed before each packed tower stage. The function of the high-voltage zone is to ionise the particles (dust, aerosols, submicron particles) contained in the flue-gas. The negatively charged particles induce opposing charges on the neutral surface of the wetted packing material and the falling water drops. As a result, they are attracted onto the liquid surfaces and are then washed out in the packed section. This is referred to as Image/Force attraction (IF attraction), i.e. attraction through electron shift. Hazardous, corrosive and odorous gases are also absorbed in the same scrubber fluid and chemically combined to be discharged with the scrubber effluent.

Another type of ionisation wet scrubber includes a venturi. The pressure changes that occur through the venturi allow the fine particles to grow and the electrode charges them. They are then collected by the dense layer of water droplets projected by a nozzle, serving as a collecting electrode. [74, TWG 2004]

2.5.3.5 Bag filters

Bag filters, also called baghouse filters or fabric filters, are very widely used in waste incineration plants. Filtration efficiencies are very high across a wide range of particle sizes. At particle sizes below 0.1 microns, efficiencies are reduced, but the fraction of these that exist in the flue-gas flow from waste incineration plants is relatively low. Low dust emissions are achieved with this technology. It can also be used following an ESP and wet scrubbers.

[74, TWG 2004]

The compatibility of the filter medium with the characteristics of the flue-gas and the dust, and the process temperature of the filter are important for effective performance. The filter medium should have suitable properties for thermal, physical and chemical resistance (e.g. hydrolysis, acid, alkali, oxidation). The gas flow rate determines the appropriate filtering surface, i.e. filtering velocity.

Mechanical and thermal stress on the filter material determines service life, energy and maintenance requirements.

In continuous operation, there is gradual loss of pressure across the filter media due to the deposit of particles. When dry sorption systems are used, the formation of a cake on the media helps to provide the acid removal. In general, the differential pressure across the filter is used to monitor the need for cleaning. Periodic replacement is required when the residual lifetime is achieved or in the case of irreversible damage (e.g. an increasing loss of pressure may be caused by an irreversible deposit of fine dust on the filter material). Several parameters help to control the lifetime of the bags: pressure drop drift, visual or microscopic analysis, etc. Potential leaks in the bag filter will also be detected by the increased emissions or by some process disturbance.

[64, TWG 2003]

Bag filter systems are usually composed of several chambers where sections can be isolated one by one for maintenance. It is common practice to design the system to operate at full capacity when one section is out of service to facilitate on-load maintenance and reduce downtime. However, there may still be constraints on how much repair work can be completed with the incinerator on-line, for example the outside of the off-line section may be too hot to allow safe personnel access due to the adjacent sections being in service.



Figure 2.35: An example of a bag filter

Selection of filter bag material

The filter material is selected to be suited to the physical and chemical conditions under which it will operate.

The key characteristics of fabrics for use in gas filtration include maximum operational temperature and resistance to acids, alkalis and flexing (due to bag cleaning). Gas humidity can also affect the strength and dimensional stability of the fabrics, due to hydrolysis. Several basic fibre properties are summarised below; some may be coated or impregnated with special chemicals (e.g. sulphur). [74, TWG 2004]

Table 2.15: Operational information for different bag filter materials

Fabric	Maximum temperature (°C)	Resistance		
		Acid	Alkali	Physical flexibility
Cotton	80	Poor	Good	Very good
Polypropylene	95	Excellent	Excellent	Very good
Wool	100	Fair	Poor	Very good
Polyester	135	Good	Good	Very good
Nylon	205	Poor to fair	Excellent	Excellent
PTFE	235	Excellent	Excellent	Fair
Polyimide	260	Good	Good	Very good
Fibreglass	260	Fair to good	Fair to good	Fair
NB: Not all of these materials are commonly used in incineration – see operational data below. <i>Source:</i> [2, InfoMil 2002] [67, Inspec, 2004]				

Increasing the temperature may lead to the melting of any plastic components in the fabric material, and the potential for fires. High humidity in the flue-gas may cause the filter materials to stick together and lead to shutdowns. [74, TWG 2004] PTFE covering of sheets/foils can be used to improve the removal of such sticky salts and solid particles from the bags. Operational improvements in semi-wet systems (see also Section 2.5.4) are reported to have been achieved by using PTFE in a MSWI facility in Prague (Czech Republic) and in Schwandorf (Germany).

Several filtration media are reported to not be commonly used in MSWI, e.g. cotton, wool, propylene. In MSWI, the main media are polyimide, PPS (rarely), PTFE, and fibreglass (with or without PTFE coating). Some fibres may be combined (e.g. polyimide and PTFE for higher resistance at high temperatures).

Chemical reactions in the absorbent media may affect the operational temperature. The quality of the scrim is also of importance, as well as the fibre quality. [2, InfoMil 2002], [64, TWG 2003]

Special filter bags may include catalytic elements for the reduction of NO_x and/or for the destruction of PCDD/F (see Sections 4.5.4.5 and 4.5.5.4).

2.5.3.6 Cyclones and multi-cyclones

[64, TWG 2003]

Cyclones and multi-cyclones use centrifugal forces to separate dust from the gas stream. Multi-cyclones differ from single cyclones in that they consist of many small cyclone units. The gas flow enters the separator tangentially and leaves from a central port. Solids are forced to the outside of the cyclone and collected at the sides for removal.

Cyclones on their own cannot achieve the required dust emission levels. They can however play an important role, where applied as a pre-deduster before other flue-gas treatment stages, in reducing the dust load to be finally treated. Energy requirements are generally low as there is almost no pressure drop across the cyclone.

A major advantage of cyclones is their wide operational temperature range and robust construction. Erosion of cyclones, particularly at the point of impingement of dirty flue-gases, can be an issue where the flue-gas is more heavily loaded with particulate, and particularly where bed material escapes from fluidised bed plants. Circulating fluidised beds usually incorporate a cyclone for the removal and recirculation of the bed material to the furnace.

2.5.3.7 Venturi scrubbers

A venturi scrubber consists of three sections: a converging section, a throat section and a diverging section. The inlet gas stream enters the converging section and, as the area decreases, the gas velocity increases. Liquid is introduced either at the throat or at the entrance to the converging section. The inlet gas, forced to move at extremely high velocities in the small throat section, shears the liquid from its walls, producing a great number of very small droplets.

Particle and gas removal occur in the throat section as the inlet gas stream mixes with the fog of tiny liquid droplets. The inlet stream then exits through the diverging section, where it is forced to slow down.

While venturitis can be used to reduce both particles and gaseous pollutants, they are mainly effective in removing fine particles.

The design can be based on a single venturi for a complete flue-gas stream or on several venturi nozzles. The pressure drop and performance can be controlled by injecting scrubbing liquid upstream of the venturi or into the venturi throat, and/or by mechanically adjusting the opening in the venturi throat.

The position of the venturi stage within a multistage wet scrubbing system can be at the inlet (venturi quench), intermediate (e.g. downstream of the quench / packed bed stage) or at the end as a last polishing stage.

Venturi scrubbers are normally combined with dry dust pre-separation (e.g. with an ESP) and/or with activated carbon injection upstream of the wet scrubber (for dioxin/mercury removal). [77, ESWET, 2015]

2.5.4 Techniques for the reduction of acid gas (e.g. HCl, HF and SO_x) emissions

Acid gases such as sulphur dioxide and gaseous halogenides are cleaned from flue-gases generally by the injection of alkaline reagents, which are brought into contact with the flue-gas. Depending on the technique, the reaction products are dissolved or dry salts. [1, UBA 2001]

The following flue-gas cleaning processes are applied:

- **Wet processes:** The flue-gas flow is fed into water, hydrogen peroxide, and/or a washing solution containing part of the reagent (e.g. sodium hydroxide solution, micronised limestone slurry). The reaction product is aqueous.
- **Semi-wet processes:** Also called semi-dry. The sorption agent added to the flue-gas flow is an aqueous solution (e.g. milk of lime) or suspension (e.g. as a slurry), or dry hydrated lime with separate water injection. The water solution evaporates and the reaction products are dry. The residue may be recirculated to improve reagent utilisation.
- **Dry processes:** A dry sorption agent (e.g. hydrated lime, high-porosity or high-surface hydrated lime, sodium bicarbonate) is added to the flue-gas flow. The reaction product is also dry.

2.5.4.1 Wet processes

Wet flue-gas cleaning processes use different types of scrubber design, for example:

- jet scrubbers;
- rotation scrubbers;
- venturi scrubbers;
- dry tower scrubbers;
- spray scrubbers;
- packed tower scrubbers.

The scrubber solution is (in the case of water-only injection) strongly acidic (typically pH 0–1) due to acids forming in the process of deposition. HCl and HF are mainly removed in the first stage of the wet scrubber. The effluent from the first stage is recycled many times, with little fresh water addition and a bleed from the scrubber to maintain acid gas removal efficiency. In this acidic medium, deposition of SO₂ is low, so a second scrubber stage is required for its removal.

Removal of sulphur dioxide is achieved in a washing stage controlled at a pH close to neutral or alkaline (generally pH 6–7) in which caustic soda solution or milk of lime is added. For technical reasons this removal takes place in a separate washing stage, in which, additionally, there occurs further removal of HCl and HF.

If the treated waste contains bromine and iodine, these elements can be deposited from the flue-gas flow if waste containing sulphur is combusted simultaneously. In addition to sulphur compounds, water-soluble salts of bromine and iodine will form, which can be deposited through the wet SO₂ flue-gas cleaning processes. Additionally, the deposition of elementary bromine and iodine may be improved by specific employment of reductive washing stages (sulphite solution, bisulphite solution). In any case, it is important to be aware of which wastes contain iodine or bromine.

If milk of lime or limestone is used as a neutralising agent in the wet flue-gas cleaning stages, sulphate (as gypsum), carbonates and fluorides will accumulate as water-insoluble residues. These substances may be removed to reduce the salt load in the waste water and hence reduce the risk of encrustation within the scrubbing system. Residues of the cleaning process (e.g. gypsum) can be recovered. When using a caustic soda solution there is no such risk because the reaction products are water-soluble. If NaOH is used, CaCO₃ may form (depending upon water hardness), which will again lead to deposits within the scrubber. These deposits need to be removed periodically by acidification.

The diagram below shows a typical two-stage wet scrubbing system. The number of scrubbing stages usually varies between one and four with multiple stages being incorporated in each vessel.

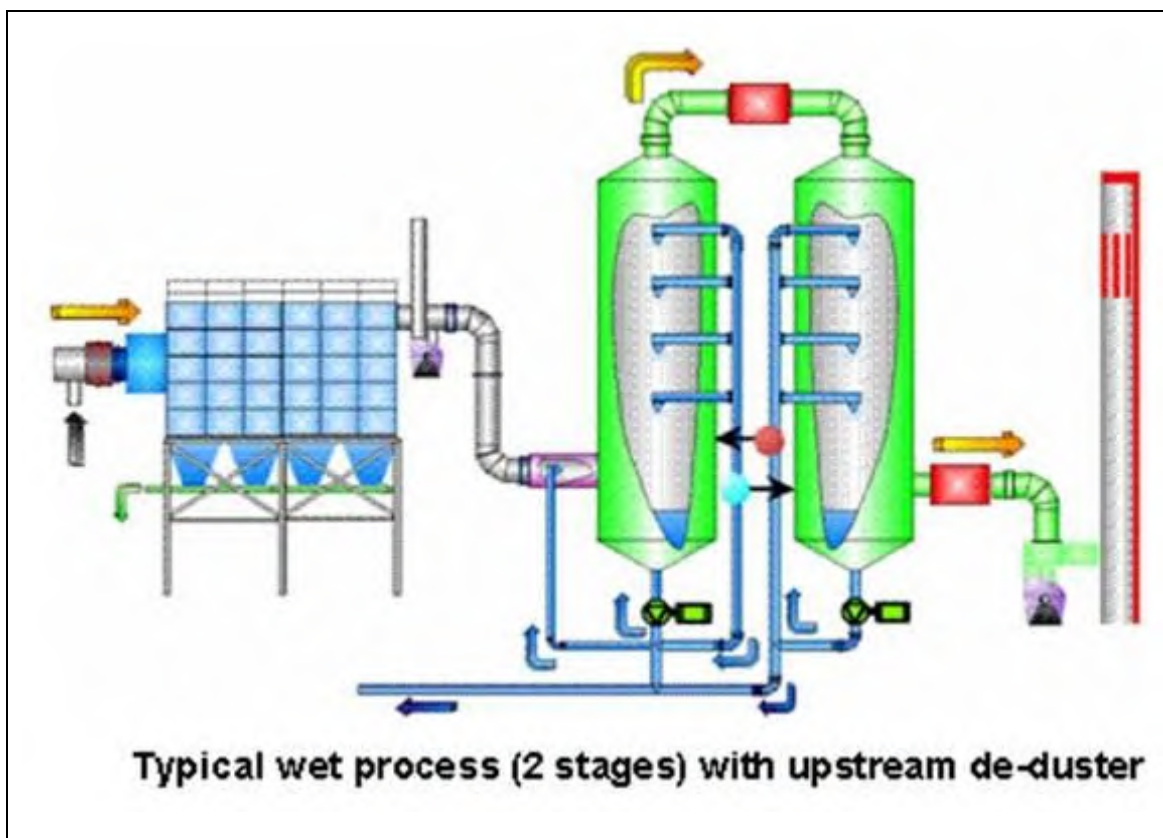

Figure 2.36: Diagram of a two-stage wet scrubber with upstream dedusting

Wet scrubbing increases the moisture in the flue-gas and therefore the plume visibility, especially with lower ambient temperature and higher humidity levels. Increasing the temperature of the flue-gases provides one way of reducing plume visibility, as well as improving the dispersion characteristics of the release; reheating the flue-gases requires however some energy. Depending on the flue-gas moisture content and atmospheric conditions, plume visibility is greatly reduced above stack release temperatures of 140 °C. Reducing the moisture content of the flue-gases by the use of condensing scrubbers (see Section 2.4.4.5) also reduces the plume visibility.

Waste water from wet scrubbers

To maintain scrubbing efficiency and prevent clogging in the wet scrubbing system, a portion of the scrubber liquor must be removed from the circuit as waste water. This waste water must be subjected to special treatment (neutralisation, precipitation of heavy metals), before discharge or use internally. Mercury removal is given special attention. Volatile mercury compounds, such as HgCl_2 , will condense when the flue-gas is cooled, and dissolve in the scrubber effluent. The addition of reagents for the specific removal of mercury provides a means of removing it from the process.

In many plants fitted with wet abatement systems, the waste water produced is evaporated in the incineration plant by spraying it back into the flue-gas as a quench in combination with a dry dust abatement system. This avoids waste water emissions from the flue-gas treatment system and avoids waste water treatment costs. Other techniques to avoid water releases are described in Section 4.6.1.

2.5.4.2 Semi-wet processes

In the version of this process that is often called semi-dry, water and hydrated lime are injected separately, typically into a conditioning tower and/or duct. In the spray absorption version, the absorption agent is injected either as a suspension or solution into the hot flue-gas flow in a spray reactor (see Figure 2.37).

This type of process utilises the heat of the flue-gas for the evaporation of the solvent (water). The reaction products generated are solid and need to be deposited from the flue-gas as dust in a subsequent stage, e.g. bag filter. Compared to dry processes, these processes are typically more efficient and require less overdosing of the sorbent.

Here, the bag filter is also an important part of the process. Plumes are also rarely visible with this technique.

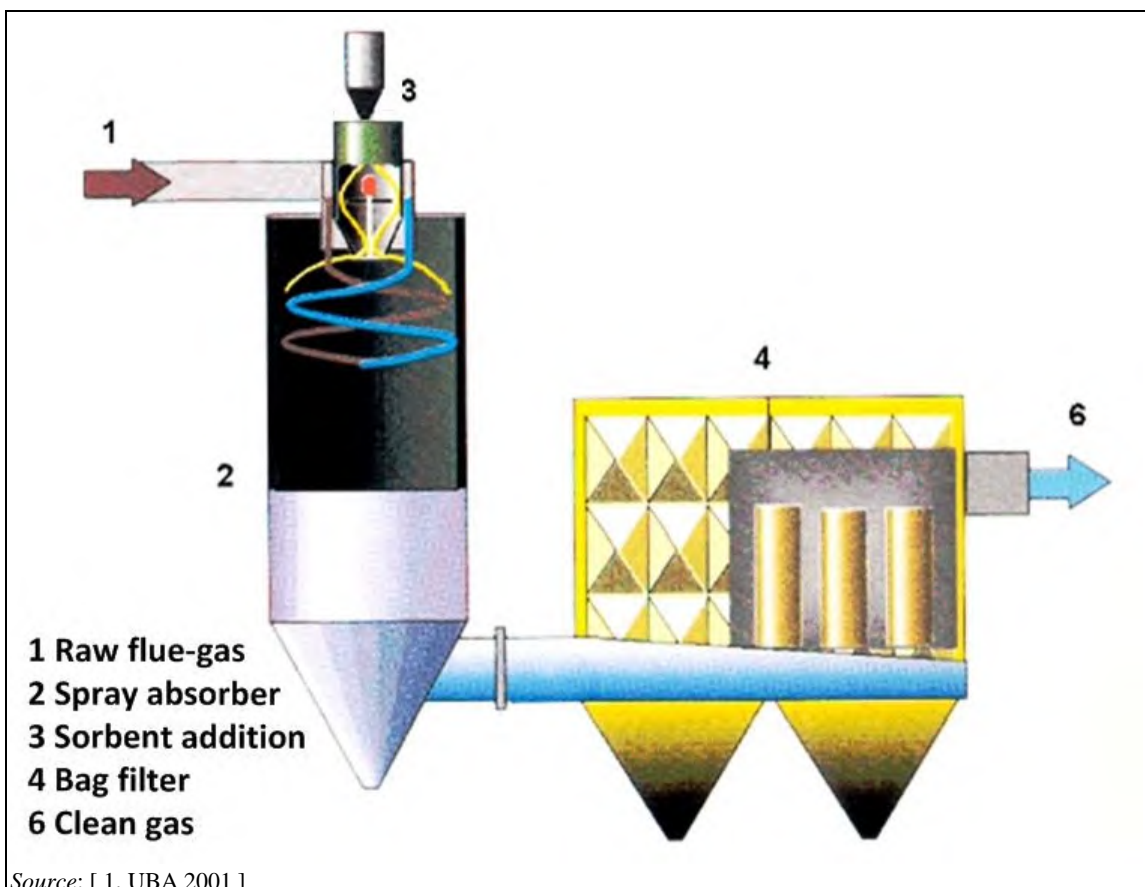

Figure 2.37: Operating principle of a spray absorber

A system which falls between the normal dry and semi-wet systems is also applied. This is sometimes known as semi-dry with CFB (circulating fluidised bed) reactor. These systems re-inject into the inlet flue-gas a proportion of the solids collected in the bag filter. Water is added at a controlled rate either directly to the collected fly ash and reagent or into the reactor upstream of the filter in such a way as to ensure that solids remain free-flowing and not prone to stickiness or scaling. The reactor design might be as a circulating fluidised bed (CFB) reactor or a simple plug-flow reactor (duct). No slurry handling is required (in contrast to semi-wet systems) and no effluents are produced (in contrast to wet systems).

The recycling of reagent reduces the demand for reagent and the amount of solid residue produced. It can also be applied to dry and semi-wet systems.

Another system that is not completely dry or semi-wet or semi-dry uses the condensation effect on solid particles recirculated into the flue-gas upstream of the fabric filter. This effect can be achieved by steam injection or by cooling the solids prior to re-feeding. [78, ESWET, 2015]

2.5.4.3 Dry processes

In dry sorption processes, the absorption agent is fed into the reactor as a dry powder. The dose rate of reagent may depend on the temperature, the $SO_2/(HCl+HF)$ ratio, the process conditions, and on the reagent type. The reaction products generated are solid and need to be removed from the flue-gas as dust in a subsequent stage, normally a bag filter.

The overdosing of reagent leads to a corresponding increase in the amount of residues, unless reagent recirculation is carried out. Significant improvements have been made over the course of the last 15 years to the techniques for the recirculation of the unreacted fraction, allowing for the reduction of the stoichiometric excess.

If there is no pre-dedusting stage (e.g. electrostatic precipitator), particles are removed with the used reagent and reaction products. The cake of reagent that forms on fabric filters provides for effective contact between flue-gas and absorbent, thus acting as a second reactor stage.

Plumes are rarely visible with this technique.

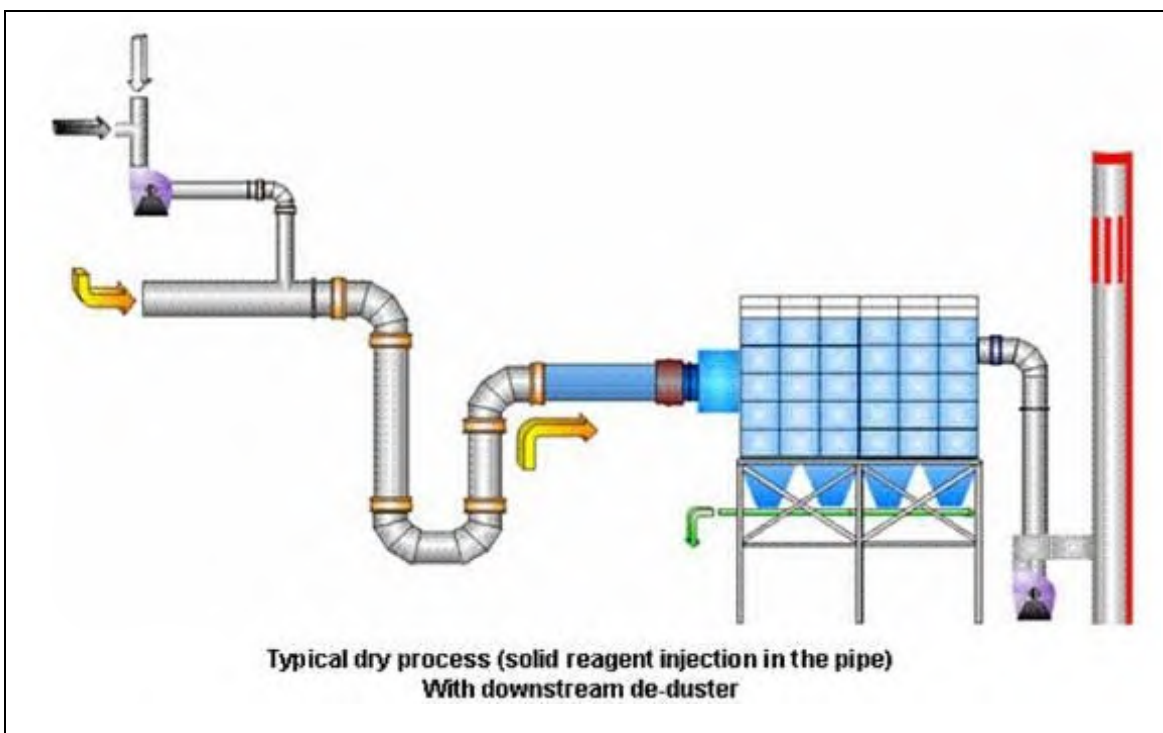

Figure 2.38: Schematic diagram of a dry FGC system with reagent injection into the FG duct and downstream bag filtration

2.5.4.4 Direct desulphurisation

[1, UBA 2001] Desulphurisation in fluidised bed processes can be carried out by adding absorbents (e.g. calcium or calcium/magnesium compounds) directly into the incineration chamber. Additives such as limestone dust, hydrated lime and dolomitic dust are used. The system can be used in combination with downstream flue-gas desulphurisation.

The arrangement of the jets and the injection speed influence the distribution of the absorbents and thus the degree of sulphur dioxide deposition. Part of the resulting reaction products is removed in filter installations downstream; however, a significant proportion remains with the bottom ashes. Therefore, direct desulphurisation may impact on bottom ash quality.

[64, TWG 2003]

Ideal conditions for direct desulphurisation exist in a cycloid furnace due to the constant temperature.

On its own, this technique does not lead to compliance with the required SO₂ emission levels. However, it is useful as a pre-treatment and contributes to meeting the lowest emission levels when applied in combination with other techniques.

The amount of residue from the flue-gas cleaning system itself can be reduced, resulting in lower disposal costs.

Absorption (and adsorption) of pollutants can also be performed in a (circulating) fluidised bed reactor into which residues and reagents are recirculated in the combustor at a high rate. Recirculation of flue-gas keeps the gas flow above a minimum level in order to maintain fluidisation of the bed. The bed material is separated in a bag filter. Injection of water reduces the consumption of absorbents (and hence the production of residues) significantly.

[74, TWG 2004]

2.5.4.5 Selection of alkaline reagent

Various alkaline reagents (and combinations) are used in FGC systems of waste incineration plants.

Calcium hydroxide is used in all types of FGC systems: wet, semi-wet (or semi-dry) and dry. For (semi-)wet systems, milk of lime can be prepared on site in a quicklime slaking unit or starting from hydrated lime. In (semi-)dry processes, hydrated lime or high specific surface (HSS) hydrated lime are used directly. [7, TWG 2017]. Sodium bicarbonate is applied to a range of mainly dry systems. Sodium hydroxide and limestone are generally only applied to wet FGC systems.

The advantages and disadvantages of the different reagents, usually strongly influenced by the overall technology selection, are summarised in the following table.

Table 2.16: Comparison of features of various alkaline reagents

Reagent	Advantages	Disadvantages	Comments/other data
Sodium hydroxide	<ul style="list-style-type: none"> Highly reactive with acid gases Low consumption rates Low solid waste production 	<ul style="list-style-type: none"> Higher cost/kg reagent Variable cost (quarterly) The waste water produced by wet sodium hydroxide processes contains soluble salts to be handled and treated Highly corrosive material 	<ul style="list-style-type: none"> Only used in wet systems Well suited to variable inlet concentrations, e.g. HWI
Quicklime and hydrated lime	<ul style="list-style-type: none"> High reactivity can be reached with HSS lime Possibility to operate at higher temperature with HSS lime Lower cost/kg reagent Low solubility residues Can allow gypsum recovery from wet scrubbers 	<ul style="list-style-type: none"> Handling can be problematic in non-optimised systems Limited options to recycle the residues 	<ul style="list-style-type: none"> Residue recirculation is possible and allows reducing specific consumption
Limestone	<ul style="list-style-type: none"> Medium reactivity Lower cost/kg reagent Low solubility residues Can allow gypsum recovery from wet scrubbers 	<ul style="list-style-type: none"> Wet limestone processes generate a purge (suspension) that needs to be handled and treated 	<ul style="list-style-type: none"> Not widely applied in MSWI Mainly used in wet systems Sometimes used in fluidised bed systems
Sodium bicarbonate	<ul style="list-style-type: none"> Highly reactive with SO₂ and HCl Low consumption rates (stoichiometric ratio 1.05–1.20) Low residue production depending on the stoichiometric ratio Purification and reuse of residue possible and applied Effective over wide FGC operating temperature range (120–300 °C) High operating temperature range and high efficiency on SO₂ may increase compatibility with SCR No water injection/humidity control required 	<ul style="list-style-type: none"> Higher soluble part in residue Soluble solid residues formed can be problematic for disposal (but use in chemical industry is possible) Higher cost than lime/kg reagent Depending on the particle granularity of the reagent as supplied, a grinding device may be required and affect availability due to possible fouling problems 	<ul style="list-style-type: none"> Typical reagent consumption ranges are 6–12 kg/t waste incinerated for MSWI and 15–40 kg/t for HW Residues without fly and boiler ash are on average 70–75% of the reagent weight
Source: [64, TWG 2003] [74, TWG 2004]			

The temperature range which is adequate for the dry sodium bicarbonate process is linked to the transformation of sodium bicarbonate to sodium carbonate; this phenomenon increases the surface area and porosity of the reagent and hence its reactivity. The phenomenon is observable from temperatures around 80–100 °C depending on the particle size, but higher temperatures are required to ensure reaction kinetics are acceptable. From 140 °C the kinetics are generally fast enough, with experience of further increases in reactivity at temperatures of 160–180 °C.

In some cases, mixed FGC systems are implemented: they can operate either with HSS lime or sodium bicarbonate, allowing for better control of reagent costs despite a possible need to compromise on process optimisation. [74, TWG 2004]

The co-injection of hydrated lime with sodium bicarbonate is also possible, and has recently been applied in plants in Germany and in the Netherlands, to make up for the lower reactivity of sodium bicarbonate with HF and thus improve the continuous control of HF emissions. The co-injection of hydrated lime has been reported to also potentially reduce the overall use of reagents and associated operating costs [99, EuLA 2015].

The overall abatement cost is determined both by the reagent cost (unit cost per kilogram of reagent and amount required) and by the residue treatment/disposal cost. The flue-gas composition (which affects the stoichiometric ratio of the different possible reagents/processes), the unit price per kilogram of reagent, as well as the availability and cost of residue treatment/disposal options are important factors influencing the total abatement cost.

Limestone, quicklime, hydrated lime, enhanced (high-surface) hydrated lime, sodium hydroxide and sodium bicarbonate are all used in a wide variety of incineration plants throughout Europe and elsewhere.

2.5.5 Techniques for the reduction of emissions of oxides of nitrogen

[3, Austria 2002]

Nitrogen oxides (NO_x) may be formed in three ways:

- Thermal NO_x : During combustion a part of the air nitrogen is oxidised to nitrogen oxides. This reaction only takes place significantly at temperatures above 1 300 °C. The reaction rate depends exponentially on the temperature and is directly proportional to the oxygen content.
- Fuel NO_x : During combustion a part of the nitrogen contained in the fuel (including in the waste) is oxidised to nitrogen oxides.
- Formation of NO_x via radical reaction (prompt NO_x): Atmospheric nitrogen can also be oxidised by reaction with CH radicals and intermediate formation of HCN. This mechanism of formation is of relatively low importance in waste incineration.

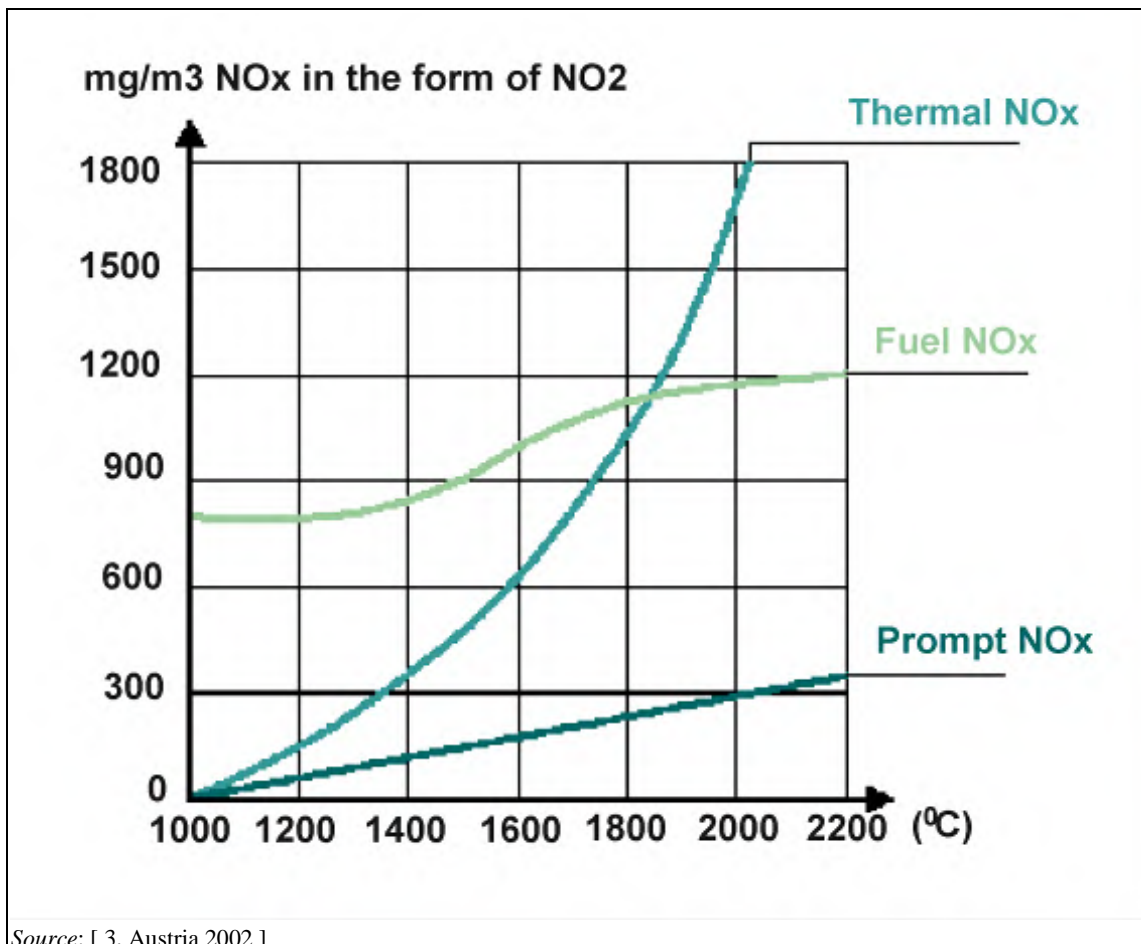

Source: [3, Austria 2002]

Figure 2.39: Temperature dependence of various NO_x formation mechanisms in waste incineration

2.5.5.1 Primary techniques for NO_x reduction

[1, UBA 2001]

NO_x production can be reduced using furnace control measures that:

- prevent oversupply of air (i.e. prevent the supply of additional nitrogen);
- prevent the use of unnecessarily high furnace temperatures (including local hot spots);
- optimise combustion control for the homogenisation of the combustion conditions and to avoid sharp temperature gradients.

2.5.5.1.1 Air supply, gas mixing and temperature control

The use of a well-distributed primary and secondary air supply to avoid the uneven temperature gradients that result in high-temperature zones and, hence, increased NO_x production is a widely adopted and important primary technique for the reduction of NO_x production.

Although sufficient oxygen is required to ensure that organic materials are oxidised (giving low CO and VOC emissions), the oversupply of air can result in additional oxidation of atmospheric nitrogen, and the production of additional NO_x.

Achieving effective gas mixing and temperature control are important elements.

2.5.5.1.2 Flue-gas recirculation

This technique involves replacement of around 10–20 % of the secondary combustion air with recirculated flue-gases. NO_x reduction is achieved because the supplied recirculated flue-gases have a lower oxygen concentration and therefore lower flue-gas temperature which leads to a decrease of the nitrogen oxide levels. [74, TWG 2004]

2.5.5.1.3 Oxygen injection

The injection of either pure oxygen or oxygen-enriched air provides a means of supplying the oxygen required for combustion, while reducing the supply of additional nitrogen that may contribute to additional NO_x production.

2.5.5.1.4 Staged combustion

Staged combustion has been used in some cases. This involves reducing the oxygen supply in the primary reaction zones and then increasing the air (and hence oxygen) supply in later combustion zones to oxidise the gases formed. Such techniques require effective air/gas mixing in the secondary zone to ensure CO (and other products of incomplete combustion) are maintained at low levels.

2.5.5.1.5 Natural gas injection (reburn)

[70, USEPA, 1994]

Natural gas injection into the over-grate region of the furnace can be used to control NO_x emissions from the combustor. For MSWIs, two different natural-gas-based processes have been developed:

- reburning – a three-stage process designed to convert NO_x to N₂ by injecting natural gas into a distinct reburn zone located above the primary combustion zone;
- methane de-NO_x – this technique injects natural gas directly into the primary combustion unit to inhibit NO_x formation.

2.5.5.1.6 Injection of water into furnace/flame

A properly designed and operated injection of water either into the furnace or directly into the flame can be used to decrease the hot spot temperatures in the primary combustion zone. This drop in peak temperature can reduce the formation of thermal NO_x.

[74, TWG 2004]

2.5.5.2 Secondary techniques for NO_x reduction

[1, UBA 2001] In order to achieve compliance with NO_x emission limits, it is common for secondary measures to be applied. For most processes, the application of ammonia or derivatives of ammonia (e.g. urea) as a reduction agent has proved successful. The nitrogen oxides in the flue-gas basically consist of NO and NO₂ and are reduced to N₂ and water vapour by the reduction agent.

Reaction equations:

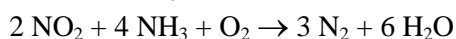
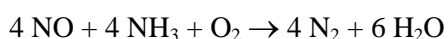

Two processes are important for the removal of nitrogen from flue-gases - selective non-catalytic reduction (SNCR) and selective catalytic reduction (SCR).

Both NH_3 and urea are applied as aqueous solutions. For safety reasons, NH_3 is normally supplied as a 25 % solution. Urea can also be applied in the pure solid form.

2.5.5.2.1 Selective non-catalytic reduction (SNCR) process

In the selective non-catalytic reduction (SNCR) process, nitrogen oxides ($\text{NO} + \text{NO}_2$) are removed by injecting the reducing agent (typically ammonia or urea) into the furnace. The reactions occur at temperatures between $850\text{ }^\circ\text{C}$ and $1\ 000\text{ }^\circ\text{C}$, with zones of higher and lower reaction rates within this range. The operating principle of the technique is illustrated in Figure 2.40.

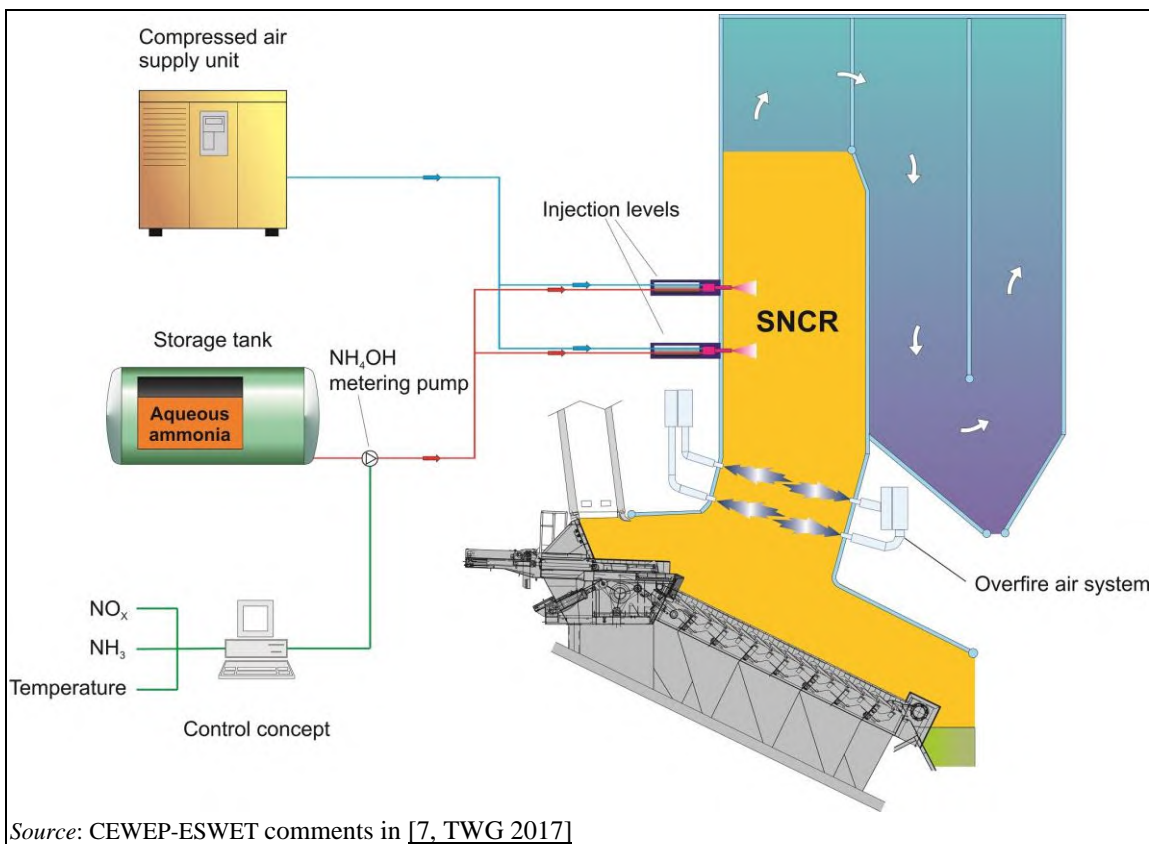

Source: CEWEP-ESWET comments in [7, TWG 2017]

Figure 2.40: SNCR operating principle

Reducing NO_x levels by more than 60–80 % using SNCR requires a higher addition of the reducing agent. This can lead to emissions of ammonia, also known as ammonia slip. The relationship between NO_x reduction, ammonia slip and the reaction temperature is given in Figure 2.41 below.

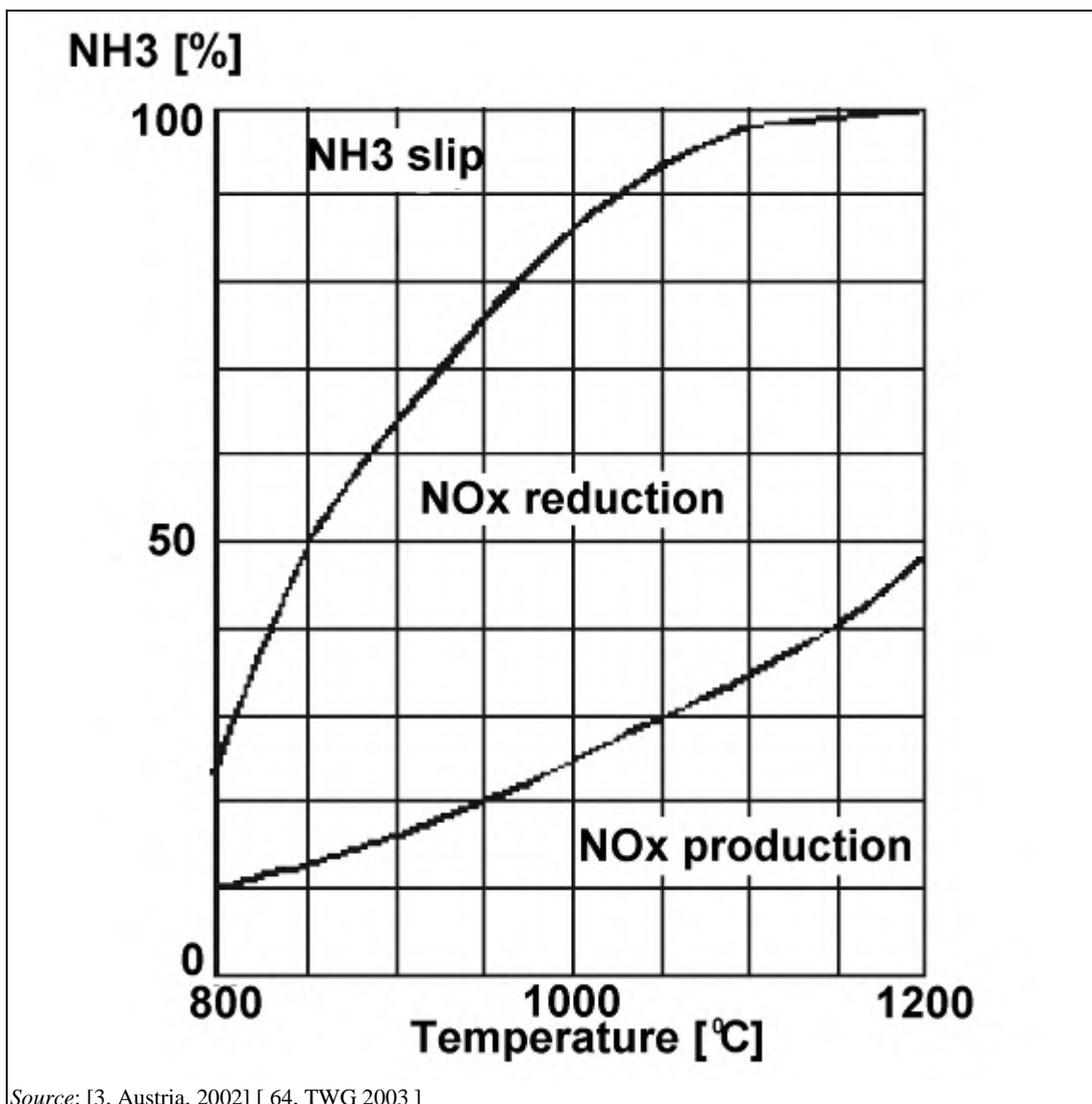

Figure 2.41: Relationship between NO_x reduction, production, ammonia slip and reaction temperature for the SNCR process

Figure 2.41 shows that, at a reaction temperature of 1 000 °C, the reduction of NO_x would be about 85 %, with an ammonia slip of about 15 %. In addition, at this temperature there would be a production of NO_x, from the incineration of the injected NH₃, of about 25 %.

Figure 2.41 also shows that, at higher temperatures (with ammonia), the percentage of NO_x reduction is higher, and, while the ammonia slip is lower, the NO_x produced from the ammonia rises. At high temperatures (> 1 200 °C), NH₃ itself oxidises and forms NO_x. At lower operating temperatures, the NO_x reduction is less efficient and the ammonia slip is higher.

Application of urea instead of ammonia in SNCR leads to relatively higher N₂O emissions in comparison with ammonia reduction. [64, TWG 2003]

In order to ensure an optimum utilisation of ammonia at varying loads, which cause varying temperatures in the combustion chamber, NH₃ can be injected into several layers.

When used with wet scrubbing systems, the excess ammonia may be removed in the wet scrubber. The ammonia can then be recovered from the scrubber effluent using an ammonia stripper and fed back to the SNCR feed system.

The effective mixing of flue-gases and NO_x reduction reagent is important for optimisation of the SNCR process and there must be sufficient gas residence time to allow the NO_x reduction reactions to occur.

In the case of pyrolysis and gasification processes, optimisation of SNCR is achieved by injecting the reagent into the syngas combustion zones with a well-controlled temperature and effective gas mixing.

Selection of reagents for SNCR

The reagents used for SNCR are ammonia and urea.

Obtaining a good understanding of temperature profiles in the combustion chamber is fundamental to the selection of the reagent.

New plants can be specifically designed to achieve stable and predictable combustion conditions, allowing for optimal injection locations for the reagent, thus making it possible to use ammonia with the maximum environmental benefit (i.e. highest peak NO_x reduction at lowest N₂O emissions). This also applies to existing plants that have stable and well-controlled combustion and temperature profiles in the furnace.

Existing plants that experience difficulties in stabilising combustion conditions (e.g. for design, control or waste type reasons) are less likely to be in a position to optimise the reagent injection (location, temperature, mixing) and may therefore benefit from the use of urea. However, if temperatures above 1 000 °C are anticipated, the N₂O production rate with urea becomes more significant.

In cases where the advantages and disadvantages are finely balanced, storage and handling hazards may have a greater impact on the final reagent selection.

The relative advantages and disadvantages of ammonia and urea are outlined in the table below. The reagent selection needs to take account of a variety of process operational, cost and performance factors to ensure that the optimal one is selected for the installation concerned.

Table 2.17: Advantages and disadvantages of urea and ammonia use for SNCR

Reagent	Advantages	Disadvantages
Ammonia	<ul style="list-style-type: none"> Higher peak NO_x reduction potential (if well optimised) Lower N₂O emissions (10–15 mg/Nm³) 	<ul style="list-style-type: none"> Narrower effective temperature range (850–950 °C) therefore greater optimisation is required Handling and storage hazards higher Higher cost per tonne of waste Odour of residues if in contact with humidity
Urea	<ul style="list-style-type: none"> Wider effective temperature range (750–1 000 °C) makes temperature control less critical Less storage and handling hazards Lower cost per tonne of waste 	<ul style="list-style-type: none"> Lower peak NO_x reduction potential (compared to ammonia when optimised) Higher N₂O emissions (25–35 mg/Nm³) and hence GWP

Source: [62, Tyseley 2001] [64, TWG 2003]

The urea/N₂O reaction is very dependent on temperature, with as much as 18 % of the NO_x removed appearing as N₂O at 1 000 °C, while it is negligible at 780 °C.

Ammonia is reported to be marginally more expensive to use than urea. Handling and storage requirements for ammonia liquid, gas and solutions are generally more stringent and, hence,

more expensive than for urea, which can be stored as a solid - this contributes to the cost differential between the two reagents.

Storage of gaseous or liquefied ammonia is subject to stringent safety requirements, which may cause extra costs. In most cases ammonia is used as a solution, as in this case the safety requirements are less onerous.

The use of urea is only cheaper for relatively small plants. For larger plants, the higher storage cost of ammonia may be fully compensated by the lower chemical cost.

2.5.5.2.2 Selective catalytic reduction (SCR) process

In the selective catalytic reduction (SCR) process, an ammonia- air mixture (the reduction agent) is added to the flue-gas and passed over a catalyst, usually a mesh (e.g. platinum, rhodium, TiO_2 , zeolites). [74, TWG 2004] When passing through the catalyst, ammonia reacts with NO_x to give nitrogen and water vapour.

To be effective, the catalyst usually requires a temperature of between 150 °C and 450 °C. The majority of systems used in waste incinerators currently operate in the range of 180–250 °C so as to minimise the need to reheat the flue-gas, even if more catalyst surface is necessary and there is a greater risk of fouling and catalyst poisoning at these lower temperatures. In some cases, catalyst-temperature-regulated bypasses are used to avoid damage to the SCR unit. [74, TWG 2004], [7, TWG 2017]

SCR gives high NO_x reduction rates (typically over 90 %) at close to stoichiometric additions of the reduction agent. For waste incineration, SCR is mainly applied in the clean gas area, i.e. after dedusting and acid gas removal. For this reason, the flue-gases generally require reheating to the effective reaction temperature of the SCR system. This adds to the energy requirements of the flue-gas treatment system. However, when SO_x levels in the flue-gas have already been reduced to a very low value at the inlet of the SCR section, reheating may be reduced substantially or even omitted. Heat exchangers are used to reduce additional energy demand.

After a wet FGC system, droplets may be removed to prevent salt deposits inside the catalyst. Due to the risk of ignition resulting from the accumulation of CO in the catalyst, safety measures are of importance, e.g. bypasses, CO control. [74, TWG 2004]

Low-temperature SCR requires low levels of SO_x (generally below 20 mg/Nm³) to minimise the risk of ammonium sulphate formation. In the event of ammonium sulphate deposition on the catalyst layers, the deposits are removed by thermal regeneration. The thermal regeneration should be carefully controlled because the salt sublimation may lead to peaks in the releases to air for some pollutants, e.g. SO_2 , NO_x , NH_3 , which can be avoided by recirculation of the exhaust gas from regeneration or by controlling the heating rate. [74, TWG 2004]

SCR is sometimes positioned directly after the ESP, to reduce or eliminate the need for reheating the flue-gas. When this option is used, the additional risk of PCDD/F formation in the ESP (typically when the ESP is operated at temperatures above 220–250 °C) must be considered. Such operation can result in increased PCDD/F emissions in the gas stream leaving the ESP and in the ESP residues. However, since SCR can also be used to provide for partial PCDD/F destruction, PCDD/F emissions downstream of the SCR are generally low.

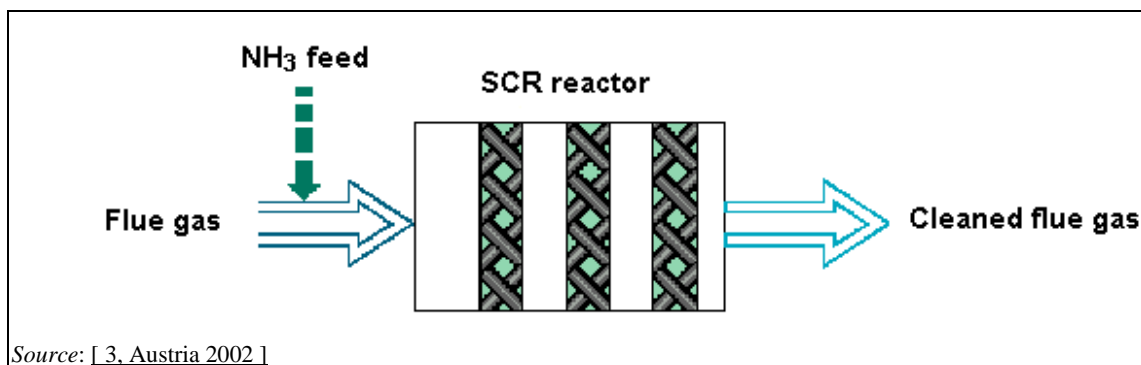

Source: [3, Austria 2002]

Figure 2.42: SCR operating principle

The flue-gases discharged from the reactor may be directed through a gas-gas heat exchanger to preheat the entering gases in order to maintain the operating temperature of the catalyst and to save some of the imported energy (see diagrams in Section 4.5.4.1).

2.5.6 Techniques for the reduction of mercury emissions

2.5.6.1 Primary techniques

Mercury is highly volatile and therefore almost exclusively passes into the flue-gas stream.

The only relevant primary techniques for preventing emissions of mercury to air are those which prevent or control, if possible, the inclusion of mercury in the waste:

- efficient separate collection of waste that may contain heavy metals, e.g. cells, batteries, dental amalgams;
- notification of waste producers of the need to segregate mercury;
- identification and/or restriction of receipt of potential mercury-contaminated wastes:
 - by sampling and analysis of wastes where this is possible;
 - by targeted sampling/testing campaigns;
- where such wastes are known to be received - controlled addition to avoid overload of the abatement system capacity.

2.5.6.2 Secondary techniques

Mercury vaporises completely at a temperature of 357 °C and remains gaseous in the flue-gas after passing through the furnace and boiler. Inorganic mercury (mainly Hg²⁺ as a chloride and, in specific cases, other halogenic compounds) and elemental mercury are affected differently by FGC systems and detailed consideration of the fate of both is required. [1, UBA 2001]

The selection of a process for mercury abatement depends on the mercury content and the chlorine content of the feed material. At higher chlorine contents, mercury in the crude flue-gas will increasingly be in the ionic form which can be deposited in wet scrubbers. This is a particular consideration at sewage sludge incineration plants where raw gas chlorine levels may be low. If, however, the chlorine content in the (dry) sewage sludge is 0.3 mass-% or higher, only 10 % of the mercury in the flue-gas [74, TWG 2004] is elemental. The presence of an SCR system in the high-dust configuration can also support the oxidation of elemental mercury and its subsequent capture in the downstream elements of the FGC system.

Elemental mercury can be removed from the flue-gas stream by the following:

- Transformation into ionic mercury by adding oxidants and then deposition in a wet scrubber - the effluent can then be fed to waste water treatment plants with heavy metal deposition, where the mercury can be converted to a more stable form (e.g. HgS), which is more suitable for final disposal [74, TWG 2004].
- The alternative option is direct deposition on brominated or sulphur-doped activated carbon, hearth furnace coke, or zeolites. Adsorption on activated carbon can take place in a fixed-bed absorber or on activated carbon injected into the gas flow. In the latter case the carbon accumulates on the bag filters used to collect it, where it forms a filter cake. The contact time and mixing with the sorbent increase when the flue-gas passes through the filter cake, enhancing mercury capture.

Tests have shown that sulphur dioxide neutralisation in the furnace by adding limestone can reduce the proportion of metallic mercury, making overall mercury removal from the gas stream more efficient.

In incineration plants for municipal and hazardous wastes, the chlorine content in the waste is usually high enough to ensure that mercury is present mainly in the ionic form. However, specific inputs of certain waste may change the situation and metallic mercury may need to be removed with the use of specific techniques, as mentioned above.

High-mercury wastes

For the incineration of waste with a high mercury content in hazardous waste incineration plants, a mercury deposition level of 99.9 % can only be ensured when highly chlorinated waste is also incinerated in an appropriate proportion to the mercury load. Multistage wet scrubbing processes are typical of this type of plant and these can achieve almost total mercury removal from the flue-gas.

High total chlorine loads (approximately 4 wt-% input) and a therefore high interim Cl₂ supply lead to high mercury chlorination levels and a mercury deposition level of close to 100 %. With lower chlorine loads, the mercury deposition reduces rapidly.

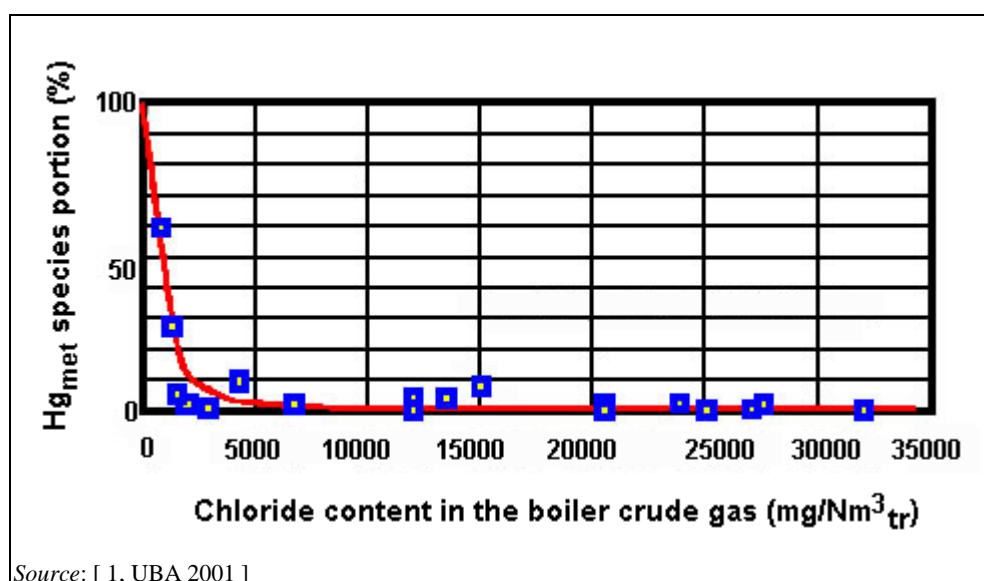

Figure 2.43: Relationship between fraction of mercury present in elemental form and the raw gas' chloride content at a hazardous waste incineration plant

2.5.7 Techniques for the reduction of emissions of other metals

Other metals in incineration are converted mainly into non-volatile oxides and deposited with fly ash. Thus, the main techniques of relevance are those applicable to dust removal (see Section 2.5.3). [1, UBA 2001]

Activated carbon is also used for reducing the emissions of other metal emissions. [74, TWG 2004]

2.5.8 Techniques for the reduction of emissions of organic carbon compounds

Effective combustion provides the most important means of reducing emissions to air of organic carbon compounds.

[1, UBA 2001] Flue-gas from waste incineration plants can contain trace quantities of a very wide range of organic species including:

- halogenated aromatic hydrocarbons;
- polycyclic aromatic hydrocarbons (PAHs);
- benzene, toluene and xylene (BTX);
- polychlorinated dibenzo-p-dioxins (PCDD) and dibenzofurans (PCDF), i.e. PCDD/F.

PCDD/F may form after the furnace from precursor compounds such as polychlorinated biphenyls (PCBs), polychlorinated diphenylmethanes (PCDM), chlorobenzenes and chlorohydroxybenzenes. PCDD/F may also form in catalytic reactions of carbon or carbon compounds with inorganic chlorine compounds over metal oxides, e.g. copper. These reactions will occur especially on fly ash or filter dust at temperatures between 200 °C and 450 °C.

The following mechanisms are believed to lead to the formation of PCDD/F in waste incineration:

1. formation from chlorinated hydrocarbons already in, or formed in, the furnace (such as chlorohydrobenzene or chlorobenzene);
2. *de novo* synthesis in the low temperature range (typically seen in boilers, dry ESPs);
3. incomplete destruction of the PCDD/F supplied with the waste.

Optimum flue-gas incineration largely destroys the precursor compounds. The formation of PCDD/F from the precursor compounds is therefore suppressed.

Adsorption processes and oxidising catalysts can be used to reduce PCDD/F emissions. Oxidising catalysts are reported to also reduce NH₃ slip and CO emissions. [74, TWG 2004]

Emissions of organic hydrocarbon compounds can also be reduced by further dust and aerosol deposition, since these pollutants preferably adsorb onto the fine fraction of dust, and by enforced flue-gas cooling (condensation).

2.5.8.1 Adsorption on activated carbon reagents in an entrained flow system

Activated carbon is injected into the gas flow. The carbon is filtered from the gas flow using bag filters. Activated carbon shows a high adsorption efficiency for mercury as well as for PCDD/F.

Different types of activated carbon have different adsorption efficiencies. This is believed to be related to the specific nature of the carbon particles, which are, in turn, influenced by the manufacturing process.

2.5.8.2 SCR systems

SCR systems are used for NO_x reduction (see description in Section 2.5.5.2.2). They also destroy gaseous PCDD/F (not particle-bound) through catalytic oxidation; however, in this case, the SCR system must be designed accordingly, since it usually requires a bigger, multi-layer, SCR system than for just the de-NO_x function. Destruction efficiencies of 98 % to 99.9 % are seen for PCDD/F.

The main reactions involved are: [74, TWG 2004]

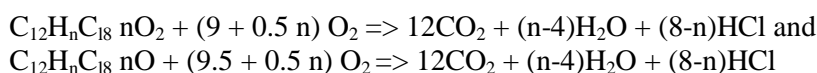

2.5.8.3 Catalytic filter bags

The filter bags installed in a bag filter are either impregnated with a catalyst or the catalyst is directly mixed with organic material in the production of fibres. Such filters have been used to reduce PCDD/F emissions as well as, in combination with a source of NH₃, to reduce NO_x.

Gaseous PCDD/F can be destroyed on the catalyst rather than adsorbed on carbon (as with carbon injection systems). The particle-bound PCDD/F fraction is removed by filtration. The catalyst has no effect on mercury and therefore it is generally necessary to implement additional techniques (such as activated carbon or sulphur reagent) to remove mercury. [74, TWG 2004]

The flue-gas temperature when entering the filter bags should be above 170–190 °C in order to achieve effective destruction of the PCDD/F and to prevent adsorption of PCDD/F in the media; the reference operating temperature for de-NO_x is 180–210 °C. [74, TWG 2004]

2.5.8.4 Reburning of carbon adsorbents

[55, EIPPCB 2002] Carbon is used to adsorb both PCDD/F and mercury at many waste incinerators. The net PCDD/F emissions from the incinerator can be reduced by feeding the spent carbon into the furnace which will reburn the adsorbed PCDD/F. However, this technique will also recycle the mercury so it can only be used where the FGC system has another means of mercury removal. Usually the additional mercury removal is provided by a low-pH wet scrubbing system, but this will only be effective when the chlorine content in the waste is consistently high enough to ensure that mercury is present mainly in the ionic form.

Examples of the application of this technique include the reburning of:

- static coke bed adsorbents;
- entrained flow activated carbon adsorbents.

Carbon-impregnated inserts used to adsorb dioxins in wet scrubbers and prevent the emission of PCDD/F that has accumulated in the cold parts of the boiler and FGC system, especially during a cold start.

In some MS, local regulations do not allow reburning.

2.5.8.5 Use of carbon-impregnated plastics for PCDD/F adsorption

Plastics are widely used in the construction of flue-gas cleaning equipment due to their excellent corrosion resistance. PCDD/F are adsorbed on these plastics in wet scrubbers, where the typical operational temperature is 60–70 °C. If the temperature is increased by only a few degrees Celsius, or if the dioxin concentration in the gas is reduced, the absorbed PCDD/F can be desorbed to the gas phase, leading to increased emissions to air. Lower chlorinated PCDD/F are subject to the highest desorption rate increase with respect to temperature rise.

[58, Andersson 2002]

The addition of tower packing in the scrubber that contains polypropylene embedded with carbon provides a means of selectively adsorbing PCDD/F (mercury is not adsorbed in the packing). This material becomes saturated after a certain period of time. Therefore the charged material can periodically be removed for disposal or, if permitted, burned in the furnace.

[74, TWG 2004]

The technique is used to remove PCDD/F and/or to prevent/reduce the re-emission of PCDD/F accumulated in the scrubber (the so-called memory effect) occurring especially during shutdown and start-up periods. [7, TWG 2017]

The technique can also be used in a more extensive tower packing installation and/or in combination with other PCDD/F removal processes. [74, TWG 2004]

2.5.8.6 Static or moving bed filters

Activated coke moving bed filters are used as a secondary FGC process in municipal and hazardous waste incineration. These filter beds can adsorb substances contained in the flue-gas at extremely low concentrations with high efficiency. Coke produced from lignite or coal in the hearth furnace coke process is used in moving bed absorbers. [1, UBA 2001]

Wet and dry coke beds are used in waste incineration. Wet systems have the addition of a countercurrent flow of water that washes the coke. In doing so, the reactor temperature is lowered and some of the accumulated pollutants are washed from the filter. When activated lignite is used in place of coke/coal, it does not require the preheating of the flue-gas above the acid dew point and can even be effectively operated with 'wet' or water-saturated flue-gas. For this reason, an activated lignite filter can be placed directly downstream of a wet flue-gas scrubber. [64, TWG 2003]

The flue-gases pass through a filling of grained hearth furnace coke (HFC – a fine coke of 1.25 mm to 5 mm). The HFC's depositing effect is essentially based upon mechanisms of adsorption and filtration. It can remove residual quantities of almost all emission-relevant flue-gas components (e.g. hydrochloric acid, hydrofluoric acid, sulphur oxides and heavy metals (mercury)), sometimes down to below the lower limit of detection.

An essential feature of the moving bed system is its high efficiency with all emissions due to the large bulk of activated coke, so that variations from incineration and upstream flue-gas cleaning caused by operation will not cause adverse effects.

The flue-gas is guided to the activated coke filling over a distributor bed equipped with a multitude of double funnels. The gas flows through them from the bottom to the top or horizontally, while the HFC passes through the absorber from the top to the bottom. In this way, an ideal distribution of the flue-gas over the whole cross-section of the absorber and an optimal utilisation of the absorber capacity are achieved with a minimum consumption of activated coke.

Care is required with such processes, to ensure temperature and CO are well monitored and controlled, to prevent fires in the coke filter. To avoid saturation and loss of activity, at certain intervals some of the pollutant-loaded coke is removed and fresh coke added to achieve continuous operation.

An alternative design is a static bed filter with carbon-impregnated polymers (plastic) to provide for the selective adsorption of PCDD/F (mercury is not adsorbed by such material). The risk of fire is very low compared to static activated carbon or coke filters. The material may become saturated after a certain period of time and is periodically disposed of (e.g. by incineration) and replaced.

2.5.8.7 Rapid cooling of flue-gases

Reducing the residence time of dust-laden flue-gas in the 450 °C to 200 °C temperature zone reduces the risk of formation of PCDD/F and similar compounds. Temperatures at the inlet to the dust removal stage should, therefore, be controlled to below 200 °C. This can be achieved by the following:

- Appropriate boiler design, where the dust residence time in the 450–200 °C range is limited to avoid transferring the problem upstream.
- Addition of a spray tower to reduce the temperature at the boiler exit to below 200 °C for the subsequent dust cleaning stages.
- Direct quenching of the flue-gases from their combustion temperature to below 100 °C with the use of a single-stage or multistage water scrubber. The technique is used in some HWIs. The scrubber must be designed to cope with the high particulate (and other pollutant) loads that will be transferred to the scrubber water and the later stages are sometimes cooled to reduce evaporative water losses with the flue-gas. With such a design, a boiler is not used and energy recovery is limited to heat transfer from the hot scrubber liquors.

2.5.9 Reduction of greenhouse gases (CO₂, N₂O)

[1, UBA 2001] There are essentially two ways of reducing greenhouse gas emissions:

- increase the efficiency of energy recovery and supply (see Sections 2.4 and 4.4);
- control CO₂ emissions using flue-gas treatment.

Production of sodium carbonate by reacting CO₂ in the flue-gases with NaOH is possible.

2.5.9.1 Prevention of nitrous oxide (N₂O) emissions

Emissions of nitrous oxide (N₂O) from waste incineration may in principle arise from:

- the use of low combustion temperatures – typically this only becomes significant below 850 °C;
- the use of SNCR for NO_x reduction (particularly where urea is the reagent).

[71, JRC(IoE), 2003] The optimum temperature for the simultaneous minimisation of both NO_x and N_2O production is reported to be in the range of 850–900 °C. When the post-combustion chamber temperature is above 900 °C, the N_2O emissions are reported to be low. N_2O emissions from the use of SCR are also low. Thus, provided that the combustion temperature is above 850 °C, in general, SNCR represents the only significant source of N_2O emissions at waste incinerators.

If not properly controlled, SNCR, especially with urea, can give rise to increased N_2O emissions. Similarly, it is possible for N_2O to be emitted from processes with sub-stoichiometric oxygen supply levels (e.g. gasification and pyrolysis) and also from fluidised bed furnaces operated under certain conditions. [74, TWG 2004]

To avoid N_2O emissions, the following techniques are used:

- reduction of SNCR reagent dosing by SNCR process optimisation;
- optimising the temperature window for the injection of the SNCR reagent;
- utilisation of ammonia instead of urea in SNCR;
- use of flow modelling methods to optimise injection nozzle locations;
- designing to ensure effective gas/reagent mixing in the appropriate temperature zone;
- over-stoichiometric burnout zones to ensure oxidation of N_2O .

2.6 Waste water treatment techniques

2.6.1 Design principles for waste water control

[2, InfoMil 2002]

The following principles are applied for the control of incineration waste water:

1. Application of optimal incineration technology

Running an optimised incineration process, important in terms of the stability of the incineration process, also provides an effective control of emissions to water where wet processes are used. Incomplete incineration has a negative effect on the flue-gas and fly ash composition, by increasing the presence of organic compounds with a polluting and/or toxic character. This, in turn, can impact on the content of the scrubber effluent.

2. Reduction of water consumption and discharge of waste water

Measures which can be taken include:

- recirculation of polluted waste water in wet or semi-wet FGC systems (e.g. wet scrubbers), including effective process control to minimise waste water discharges;
- cooling of polluted waste water from wet FGC systems (see also condensing scrubbers in Section 2.4.4.5) which results in lower water losses to flue-gases and therefore reduced water consumption; this design can eliminate cooling water consumption;
- application of waste-water-free FGC technology (e.g. semi-dry or dry sorption systems);
- use of boiler drain water as water supply for the scrubber;
- treatment of laboratory waste water in the scrubber;
- application of a waste-water-free bottom ash discharger;
- use of leachate from open-air bottom ash storage areas as feed water to the bottom ash discharger;
- use of segregated drainage to enable direct discharge of clean rainwater from roofs and other clean surfaces;
- use of roofed enclosures to reduce the exposed surface areas used for waste storage and handling.

3. Compliance with relevant water emission standards

Some process options will be greatly affected by local factors. An example is the discharge of salt effluent from scrubbers. While such discharges may be acceptable to marine environments, discharges to fresh water bodies require the consideration of dilution factors, etc. Such decisions may therefore cause fundamental changes to incineration process design, particularly the FGC system and effluent treatment selection.

4. Optimal operation of the water treatment systems

Having sufficient storage capacity for the buffering of waste water storage can allow time for operators to react to disturbances in the process conditions and ensure the optimal operation of the waste water treatment system.

2.6.2 Influence of flue-gas cleaning systems on waste water

[2, InfoMil 2002]

The production of waste water depends on the type of FGC system used. The main FGC options are:

1. dry flue-gas cleaning;
2. semi-wet flue-gas cleaning;
3. wet flue-gas cleaning:
 - a) with physical/chemical scrubber effluent treatment;
 - b) with in-line scrubber effluent evaporation;
 - c) with separate scrubber effluent evaporation.

Of these options, only option 3(a) has a waste water stream for discharge. Treatment options for the scrubber effluent from system 3(a) are discussed in the following sections, along with the techniques used to evaporate effluent in options 3(b) and 3(c).

2.6.3 Processing of waste water from wet flue-gas cleaning systems

The process waste water resulting from wet FGC contains a wide variety of polluting components. The amounts of waste water and concentrations depend on the composition of the waste and on the design of the wet flue-gas system. The recirculation of waste water in wet FGC systems can result in a substantial reduction in the amount of waste water, and as a consequence, in higher concentrations of pollutants.

Three main methods are applied for treatment of the waste water from wet FGC systems:

- **Physico-chemical treatment** based on pH correction and sedimentation. With this system, a treated waste water stream containing dissolved salts is produced and, if not evaporated (see below), requires discharge.
- **Evaporation in the waste incineration process line** by means of a spray dryer, into a semi-wet FGC system, or other system that uses a bag filter. In this case, the dissolved salts are incorporated in the residue of the FGC system. There is no emission of waste water. For more details see Section 2.6.3.7.
- **Separate evaporation** of waste water. In this case, the evaporated water is condensed, but as it is generally very clean it can often be discharged (or reused) without special measures. For more details see Section 2.6.3.7.

These are discussed further in the following sections. Some of these techniques are also described in the CWW BREF published in 2016.

If SNCR is used for NO_x control with a downstream wet FGC system, the waste water will contain high levels of NH₃, which may require treatment by NH₃ stripping. [74, TWG 2004]

2.6.3.1 Physico-chemical treatment

A typical set-up of a physico-chemical treatment unit for process waste water is given in Figure 2.44 below.

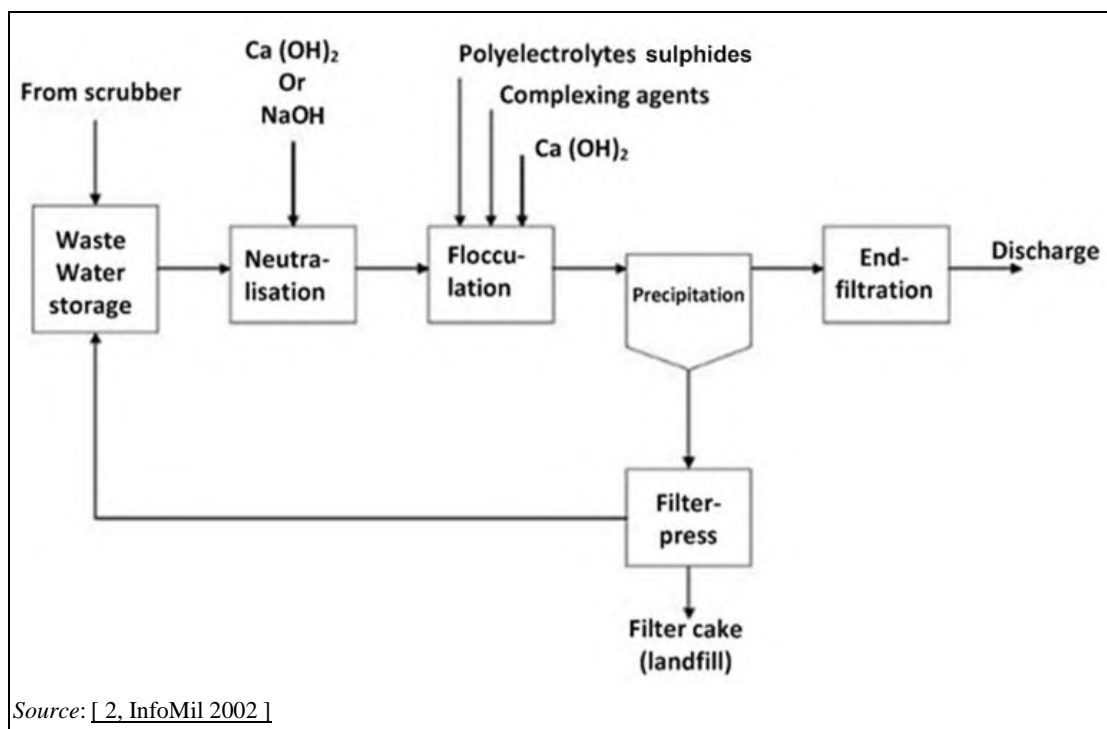

Figure 2.44: Process scheme for physico-chemical treatment of waste water from a wet flue-gas cleaning system

The process steps that can be used are :

- pH control (neutralisation);
- temperature control;
- precipitation (e.g. of heavy metals);
- coagulation;
- flocculation of pollutants;
- settlement of the formed sludge;
- dewatering of the sludge;
- filtration of the effluent ('polishing').

Hydrated lime is often used for neutralisation and this results in the precipitation of sulphites and sulphates (gypsum). Where discharging of sulphites/sulphates to surface water is allowed (e.g. some marine environments), caustic soda (NaOH) can be used instead of hydrated lime, resulting in a substantially lower production of sludge.

Removal of heavy metal compounds is based on flocculation, followed by precipitation. Heavy metal compounds have a very low solubility within a pH range of 9–11. Above a pH of 11, heavy metals can redissolve again. The optimal pH is varies for different heavy metal compounds. In particular, the optimal pH for nickel and cadmium deviates from that of other heavy metals.

Two-step (or more) neutralisation improves the stability and control of discharge acidity (pH). The first step is a coarse neutralisation, especially in the case of waste water from the first acid step of the scrubbing system. The second step is a fine neutralisation. The provision of sufficient waste water storage capacity helps to maintain a steady operating regime by providing a buffering capacity.

The flocculation of heavy metal hydroxides takes place under the influence of flocculation agents (polyelectrolytes) and FeCl_3 . The additional removal of mercury and other heavy metals can be achieved if complex-builders are added.

The precipitation of fluorides requires a pH range between 8 and 9. [74, TWG 2004]

Precipitation generally takes place in settling tanks or in lamellar separators.

The resulting sludge is normally dewatered in filter presses. Dry solids contents of 40–60 % can be achieved, depending on the chemicals used and on other conditions.

If required, for filtration of the resulting effluent ('polishing'), sand filters and/or active carbon filters can be used. The direct effect of sand filters is mainly a reduction of suspended solids, but this also results in a reduction of heavy metal concentrations. Filtration with active carbon is especially effective for the reduction of PCDD/F, PAHs, etc. The active carbon needs to be replaced regularly. Other filtration systems are also used (e.g. disc filters).

Physico-chemical waste water treatment units require special operational attention, as they are sensitive systems.

2.6.3.2 Application of sulphides

In order to carry out flocculation, organic agents (e.g. polyelectrolytes) are commonly used. The addition of complex-builders and sulphides (e.g. Na_2S , trimercapto-s-triazine - TMT) allows further reductions in mercury and other heavy metal discharges.

The use of sulphides requires special safety regulations because of their toxicity. One advantage of their use is the lower costs of sulphides in comparison with other complex-builders.

2.6.3.3 Application of membrane technology

One option for treatment of waste water polluted with salts and micro-pollutants is membrane filtration. This technique is especially efficient for large water flows with relatively low salt concentrations. With higher salt concentrations, energy consumption increases rapidly.

The salt content of the process waste water of waste incineration is high (up to 10 wt-%). Therefore, this option usually requires significant additional energy consumption.

The remaining water with a high solute concentration has to be removed via an appropriate outlet. [74, TWG 2004]

2.6.3.4 Stripping of ammonia

For the application of SNCR de- NO_x , the waste water from the wet scrubber contains ammonia compounds. The actual ammonia concentration depends on the process conditions of the SNCR de- NO_x unit. Depending on the actual ammonia concentration, stripping of ammonia from the effluent may be an option.

An ammonia-stripping unit consists mainly of a heated distillation column. The vapours are condensed, resulting in an ammonia solution. Though the ammonia concentration is normally below the original concentration of the trade product, the solution can be reused in the SNCR process.

Stripping of ammonia requires an increase in the pH to 11–12.5 and the use of steam. Fouling risks are reported when used with lime neutralisation.

2.6.3.5 Separate treatment of waste water from the first and last steps of the scrubbing system

The first step(s) of wet scrubbing systems are typically operated at a very low pH level. Under these process conditions, HCl specifically is removed from the flue-gas stream. The removal of SO₂ takes place in the final step, at a neutral pH.

If these two effluent streams are dealt with separately, the waste water treatment process can be optimised for each stream and recyclable gypsum can be recovered from the SO₂ scrubber effluent.

The waste water from the first step of the scrubber is neutralised with hydrated lime or milk of lime, followed by removal of heavy metal compounds by flocculation and precipitation. The treated waste water, containing mainly CaCl₂, is mixed with the waste water from the final step, mainly containing Na₂SO_{3/4}. This results in the formation of gypsum and a liquid effluent, mainly consisting of NaCl.

Depending on local conditions, this salty waste water is either discharged or evaporated. Evaporation results in the production of NaCl.

Because the salt is separated from other flue-gas cleaning residues contained in the effluent, this results in a very substantial reduction in the mass of residues - the precipitated sludge of heavy metal compounds is the only residue which remains.

2.6.3.6 Anaerobic biological treatment (conversion of sulphates into elementary sulphur)

One of the problems with discharging the treated waste water may be the remaining content of sulphates. Sulphates can affect concrete sewerage systems. To solve this problem, a system has been developed for anaerobic biological treatment of waste water from waste incineration.

The sulphates in the waste water can be reduced to sulphides in a reactor, by the activity of anaerobic bacteria. The effluent of this reactor, which has a high content of sulphides, is treated in a second reactor. In this second reactor, the sulphides are biologically oxidised in an aerobic atmosphere into elemental sulphur. Care must be taken to ensure that adequate oxygen is available in the aerobic stage; otherwise, thiosulphate will be produced instead of elemental sulphur and this will restrict disposal of the waste water.

Subsequently the sulphur is removed from the waste water in a laminated separator. The collected sludge is dewatered in a decanter, resulting in a sulphur cake, which can be used. The remaining waste water can be reused in the scrubber and/or discharged.

It is reported that this technology may be difficult to apply to waste water originating from hazardous waste incinerators [64, TWG 2003].

2.6.3.7 Evaporation systems for process waste water

If the discharge of soluble salts (chlorides) is not acceptable, the process waste water needs to be evaporated. For this purpose, two main options exist:

- in-line evaporation;
- separate evaporation.

2.6.3.7.1 In-line evaporation

In this configuration, the waste water is recycled in the process by means of a spray dryer. Figure 2.45 below gives an overview of the process configuration.

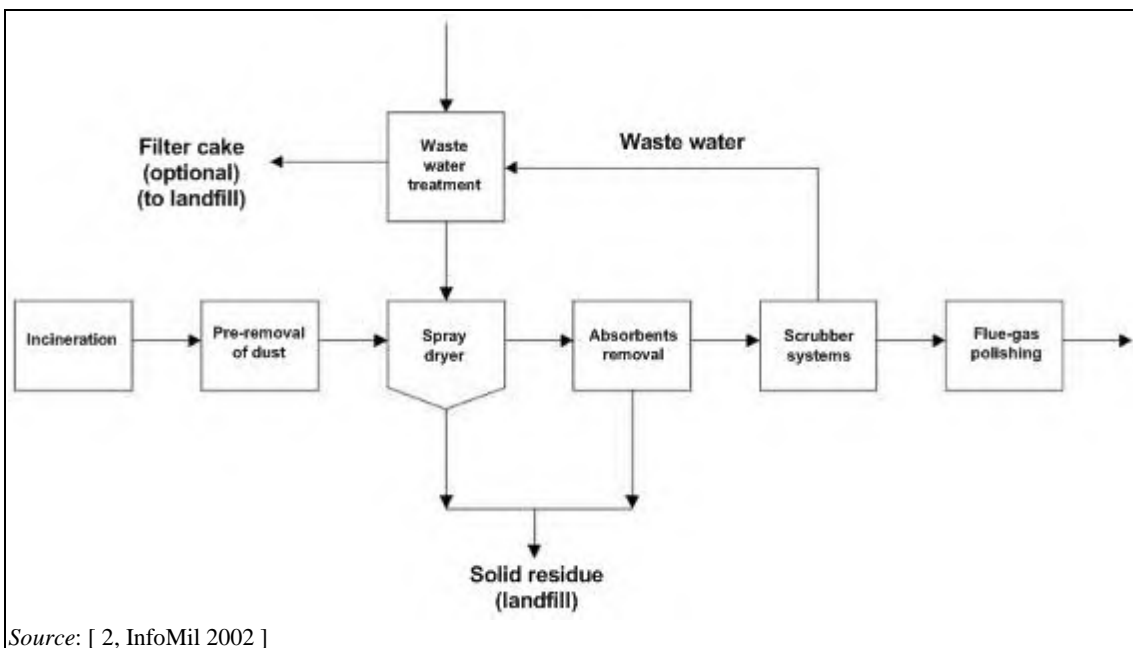

Figure 2.45: In-line evaporation of waste water from wet scrubbing

The spray dryer is comparable with the spray absorber used in the semi-wet FGC system. The difference is that, in the case of semi-wet treatment, milk of lime is injected and, for in-line evaporation, the waste water from the scrubber is used for injection after a neutralisation step. This neutralisation step can be combined with flocculation and the settling of pollutants, resulting in a separate residue (sludge). In some applications, hydrated lime is injected into the spray absorber for gas pre-neutralisation.

The neutralised waste water, containing soluble salts, is injected into the flue-gas stream. The water evaporates and the remaining salts and other solid pollutants are removed in a dust removal step (e.g. ESP or bag filter). This flue-gas cleaning residue consists of a mixture of fly ash, salts and heavy metals.

Due to the application of a wet scrubbing system, the consumption of chemicals is approximately stoichiometric and consequently residue production is lower than in semi-dry FGC systems.

2.6.3.7.2 Separate evaporation

Separate evaporation is based on evaporation in steam-heated evaporation systems. Figure 2.46 below gives an example of a process scheme.

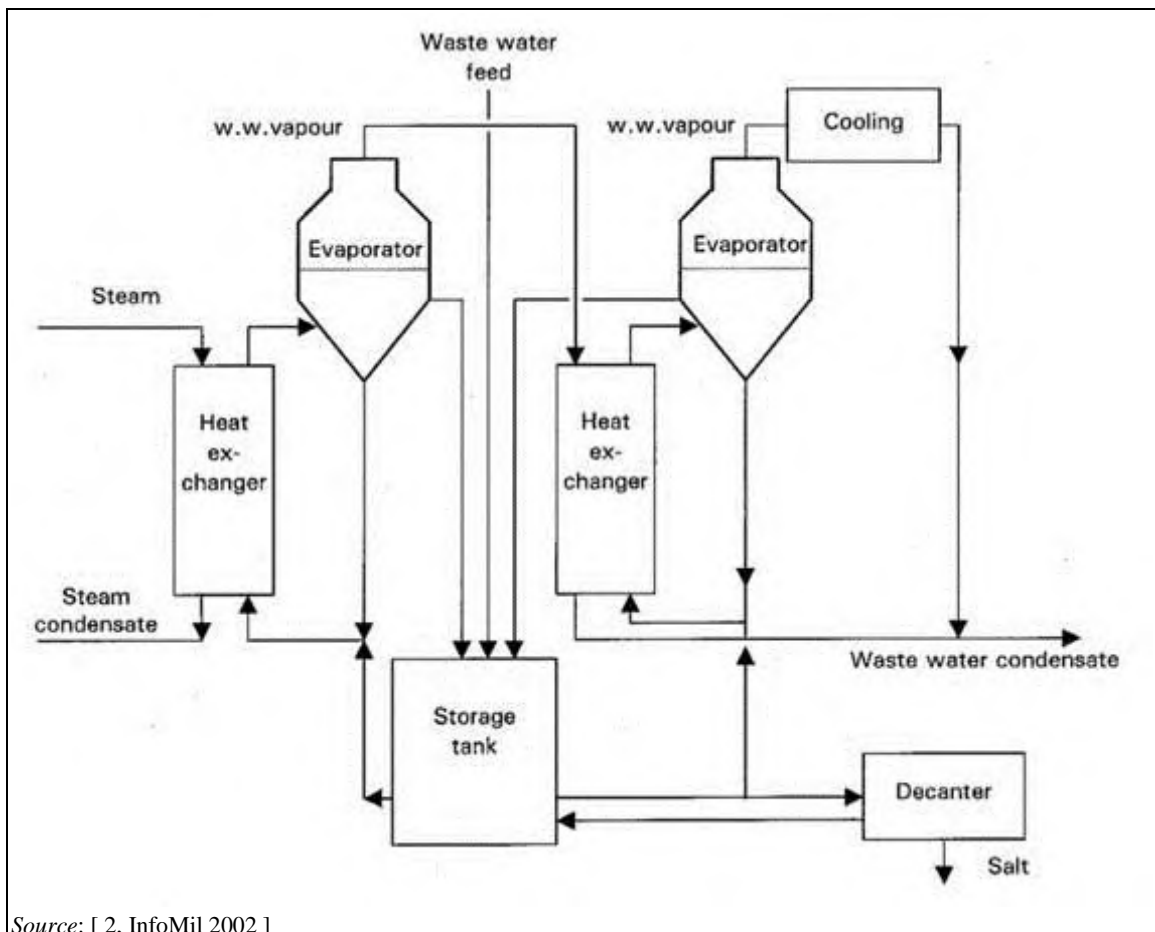

Source: [2, InfoMil 2002]

Figure 2.46: Separate evaporation of scrubber effluent from wet scrubbing

The waste water, containing soluble salts, is fed into a storage tank containing a mixture of waste water and already partially evaporated liquid. Subsequently, the water is partly evaporated in a reactor under low pressure. The required heat is supplied by (low-pressure) steam and transferred to the liquid in a heat exchanger. The surplus liquid flows back to the storage tank. The vapours are cooled down, resulting in a clean condensate, which is then discharged.

Due to the increasing salt concentrations in the liquid, crystallisation of salts begins. Subsequently, the salt crystals are separated in a decanter and collected in a container.

Figure 2.46 shows a two-stage process, where two evaporators are installed. The input of heat for the second evaporator is from the first evaporator, thus reducing the specific energy consumption. Additionally, if not used for some other purpose (e.g. district heating), the effective energy consumption may be reduced as low-pressure steam can be used.

This technique requires energy and there may be operational risks such as fouling of the crystallisation. [64, TWG 2003]

2.6.3.8 Stripping or evaporation of hydrochloric acid

[1, UBA 2001]

When wastes containing chlorine are combusted, hydrogen chloride is formed. Hydrogen chloride is absorbed in water, forming hydrochloric acid. The resulting hydrochloric acid is a colourless liquid and free of impurities after treatment. It is an aqueous solution with an HCl concentration of approximately 19 wt-% and can be used as a raw material in different consumer installations, e.g. for pH control in chlorine-producing plants.

In the production of hydrochloric acid, the flue-gases leaving the steam boiler are first discharged into a quench and cooled down. The quench unit lining contains jets through which hydrochloric acid from the downstream washing column is sprayed into the flue-gas. A portion of the hydrochloric acid is then evaporated, which causes the flue-gases to cool down.

The hydrochloric acid is transferred from the quench to the washing column together with the cooled flue-gas. In the washing column, hydrogen chloride and other acid gases contained in the flue-gas are absorbed. The hydrochloric acid is then transferred to a temporary storage tank. The flue-gas, now stripped of hydrogen chloride, leaves the acid washing column via a mist eliminator installed at the head of the column and enters the ionisation wet scrubber.

The hydrochloric acid generated in the acid washing column of the flue-gas washing system is stripped of dissolved salts and solids in an evaporator system. This cleaning step can enable the hydrochloric acid to be used as feedstock in a variety of production plants.

From the temporary storage tank, a pump transfers the hydrochloric acid to an evaporator. Here, the raw acid is upgraded in a vacuum to become an azeotropic mixture. The excess water and small amounts of hydrogen chloride pass into the vapour phase and are condensed with water in an adsorption tower.

From the vacuum unit, the process liquid is pumped into the waste water plant together with the excess water. The raw acid, upgraded to an azeotrope, will evaporate and then condense again. The remaining acid containing solids and heavy metals is drawn from the evaporator and pumped into a mixer for neutralisation purposes.

[64, TWG 2003]

2.6.4 Waste water treatment at hazardous waste incinerators

Of the European HWI installations, 55 % do not discharge waste water; they either use systems that do not generate waste water (e.g. dry or semi-dry FGC) or evaporate the water via the stack by means of spray dryers or in a separate evaporation plant, sometimes after treating the waste water to remove mercury [74, TWG 2004]

The remaining 45 % of European HWI installations have a waste water treatment facility, typically as described in Figure 2.47 below, and can be summarised as follows.

A general distinction can be made between the incinerators equipped with a boiler and those equipped with a quick quench-cooling system, with the flow of discharged effluent being greater for the latter due to technical reasons. (Note: some HWI installations are equipped with both a quick quench-cooling system and a boiler) [74, TWG 2004]. Installations equipped with a boiler discharge between < 1 l/kg and 5 l/kg of incinerated waste. Installations with only quench-cooling systems discharge between 10 l/kg and 20 l/kg of incinerated waste, although they can reduce their water flow to 5 l/kg by recirculating the effluent of the waste water treatment plant or recycling within the quench unit itself.

Normally, the effluents of the acidic section of the wet gas cleaning (containing NaCl, CaCl₂, Hg, CaF₂ and SO₃) are mixed with the effluent of the alkaline section (containing Na₂SO₄) in

order to precipitate part of the gypsum (and to decrease the sulphate content of the effluent to less than 2 g/l, which is the solubility concentration of gypsum) before further treatment. There is, however, one installation where the effluents of acidic and alkali scrubbers are treated separately.

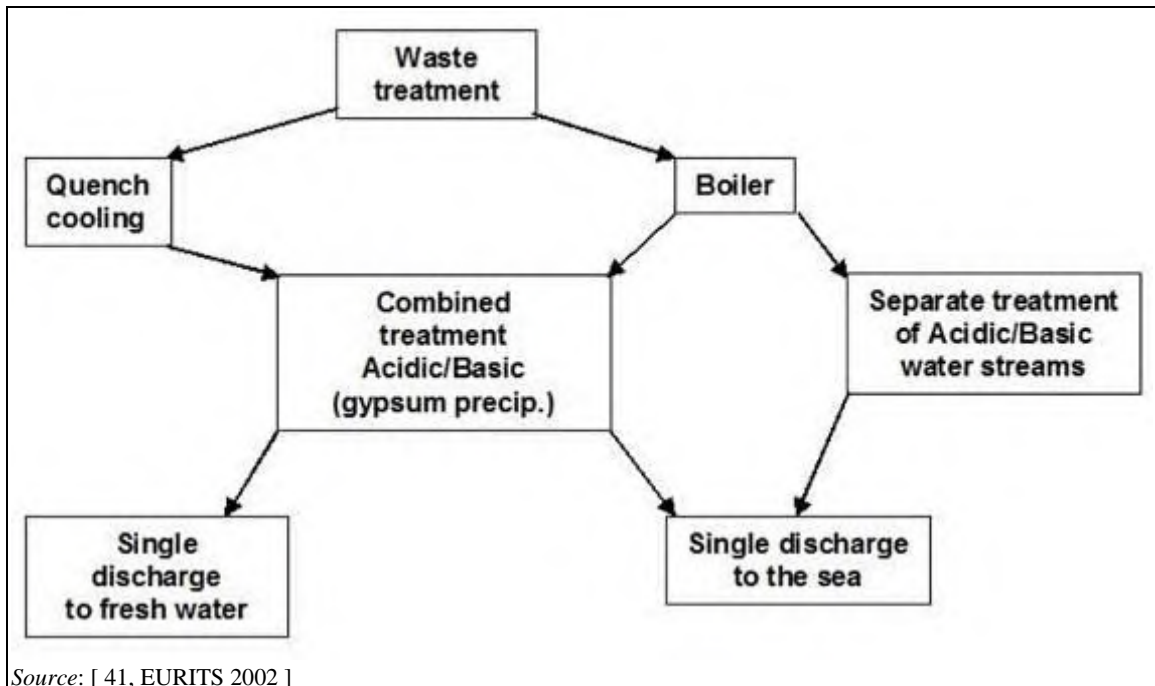

Figure 2.47: Overview of applied waste water treatment systems at merchant HWIs

Whether an installation has an on-site waste water treatment plant or transfers the waste water to an external treatment plant depends on its location.

Figure 2.48 below gives a typical set-up of a waste water treatment plant for the treatment of effluents from the wet flue-gas cleaning section of hazardous waste incineration.

The main elements of these facilities are:

- neutralisation (e.g. addition of lime, NaOH/HCl);
- the addition of reagents specifically for the precipitation of metals as hydroxides or metal sulphides (e.g. flocculation agents, trimercapto-s-triazine, sulphides, polyelectrolytes);
- the removal of sediment: either using sedimentation by gravity and decantation, or using mechanical techniques such as a filter press or centrifuge.

In some waste water treatment plants, the waste water is polished by passing it through a **sand filter**, followed by an **activated carbon filter**.

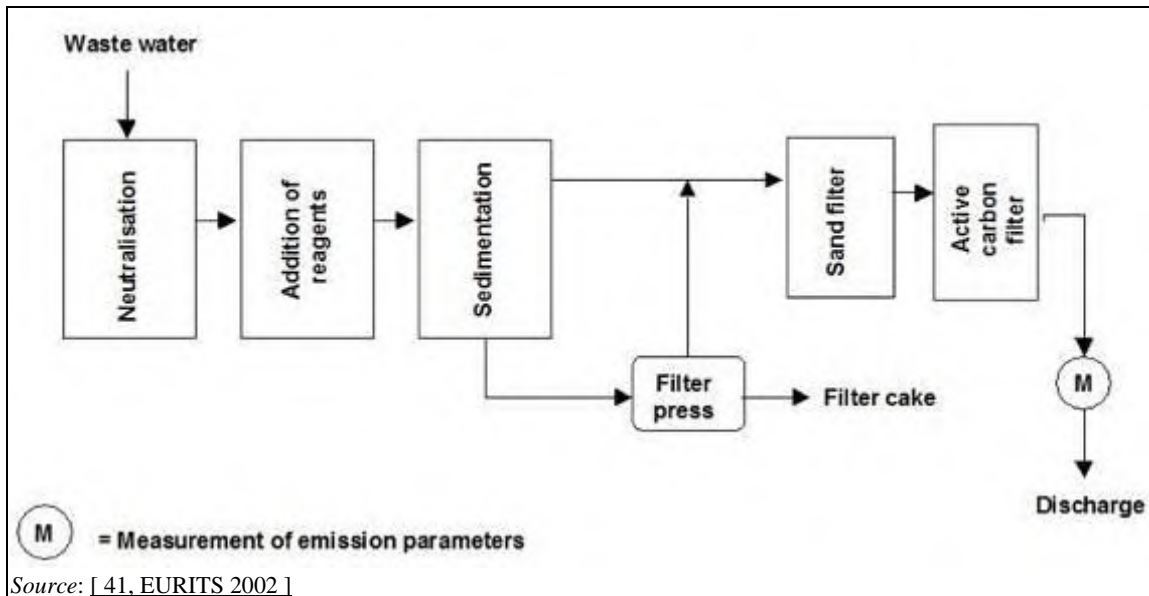

Figure 2.48: Example of a waste water treatment facility in the merchant HWI sector

2.7 Solid residue treatment techniques

2.7.1 Types of solid residues

Waste incineration creates various types of solid residues:

- **bottom ash** is the solid residue removed from the combustion chamber after the waste has been incinerated;
- **fluidised bed ash** is the solid residue removed from the fluidised bed after the waste has been incinerated;
- **slag** is the solid melted residue removed from the combustion chamber after the waste has been incinerated;
- **fly ash** comprises the particles from the combustion chamber or formed within the flue-gas stream that are transported in the flue-gas;
- **boiler ash** is the part of the fly ash that is removed from the boiler;
- **FGC residues** are a mixture of the pollutants originally present in the flue-gas and the substances that are used to remove those pollutants;
- **spent catalyst** is the used catalyst that has been replaced;
- **sludge** is the solid residue removed from the wet scrubber or from the waste water treatment plant.

2.7.1.1 Residues arising directly from the incineration process

These residues may vary depending on the type of waste incinerated and on the applied incineration process.

Municipal waste incineration

- **Bottom ash.** This is an important residue of municipal waste incineration because of the large amount generated. Most municipal waste incinerators use a wet discharge system for the bottom ash, and some use a dry discharger. The ensuing bottom ash treatment may also be either a wet or a dry process (see Section 4.7.5 and Section 4.7.6). The bottom ash is referred to as fresh bottom ash when first removed from the incinerator, raw bottom ash while awaiting treatment and aged bottom ash when it has been treated, then stored for a period of time. [75, FEAD, 2014]
- **Siftings** (or riddlings) are particles that have fallen through the grate during incineration. In some cases, they are fed again to the furnace.
- **Fly ash.** This type of waste is mostly disposed of, often after pre-treatment, but has also been used as a filling material for bitumen-bound applications in civil construction, in countries where this practice is permitted [74, TWG 2004]. An additional option is the recovery of metals such as zinc, lead, copper and cadmium, which has been implemented on a large scale in Switzerland [65, BAFU 2010]. Treatment and disposal are discussed further below.
- **Boiler ash** is often treated together with the fly ash. In some countries (the UK and the Netherlands for example), it may be treated together with the bottom ash. [74, TWG 2004]

Hazardous waste and specific clinical waste incineration

- **Slag** is disposed of by landfill without further treatment, or may be recycled if locally permitted.
- **Fly ash** is similar to that arising from MSWI but because it may contain higher levels of pollutants it is generally been disposed of.

Sewage sludge incineration

- **Fly ash** can be used without further treatment as a filling material for bound applications in civil construction, in countries where this practice is permitted. In Germany, it is also used for backfilling of mines. Unused fly ash is landfilled. The fly ashes of incineration plants exclusively dedicated to the incineration of sewage sludge contain high amounts of P_2O_5 and have been indicated as a potential secondary source of phosphorus.
- **Fluidised bed ash** The quantity produced is relatively small and is often added to the fly ash or landfilled without further treatment.

RDF incineration

- **Fluidised bed ash.** Depending on the specific characteristics of the material, fluidised bed ash amounts may be substantially higher than for sewage sludge incineration. There is little experience of its reuse.
- **Fly ash** resulting from small- and medium-scale incineration of wood waste. The quantity produced is relatively small and is not discussed further.

Some installations operate at particularly high temperatures (e.g. $> 1\,400\text{ }^\circ\text{C}$) with the specific aim of melting the bottom ash to form a slag which has improved use options owing to lower leachability, etc. High-temperature slagging rotary kilns and combined gasification-combustion processes are examples of such systems. The latter is used in Japan, where very strict leachability criteria are applied to MSWI residues, specifically to increase residue reuse and reduce the need for landfill.

Both within and beyond Europe, there are variations in policy and procedures regarding the reuse of residues from incinerators. [74, TWG 2004]

2.7.1.2 Residues arising from the FGC system

FGC residues are a mixture of the pollutants originally present in the flue-gas and the substances that are used to remove those pollutants. FGC residues contain concentrated amounts of pollutants (e.g. hazardous compounds and salts) and therefore are not normally considered suitable for recycling. The main objective is then to find an environmentally safe final disposal option. The following types of flue-gas cleaning residues can be distinguished:

- **Residues from dry and semi-wet flue-gas treatment** are a mixture of calcium and/or sodium salts, mainly as chlorides and sulphites/sulphates. There are also some fluorides and unreacted reagent chemicals (e.g. hydrated lime or sodium carbonate). This mixture also includes some fly ash that has not been removed by any preceding dust removal step. It can, therefore, also include polluting heavy metals and PCDD/F. The normal disposal method is landfilling as hazardous waste, often in big bags or, after cementation, in blocks. The leachability of the residues is an important parameter for landfill disposal. Various treatments can be applied to lower the leachability prior to landfilling and these are described in the WT BREF. The FGC residues coming from the dry sodium bicarbonate process can be purified and recycled. [74, TWG 2004]

- **Sludge** from the physico-chemical treatment of waste water from wet flue-gas treatment is characterised by a very high heavy metals content, but can also include salts of limited solubility, such as gypsum. The normal disposal method is landfilling (as hazardous waste). These residues may contain high levels of PCDD/F and are therefore sometimes pretreated before landfilling.
- **Gypsum** may also be recovered with or without cleaning depending on the process parameters and quality requirements. Recovery is possible when limestone or hydrated lime is used in a two-stage wet scrubber with an efficient droplet separator. [74, TWG 2004] The recovered gypsum can be recycled in some circumstances.
- **Salts** resulting from in-line evaporation of waste water. This residue is comparable with the residue from (semi-)dry flue-gas treatment.
- **Salts** resulting from separate evaporation of waste water. Salt use or disposal depends on the composition of the residue. It is usually purer than where in-line evaporation has been carried out.
- **Residues from dry sorbent injection.** Options for use depend on the sorbent used (activated carbon, cokes, hydrated lime, sodium bicarbonate, zeolite). The residue of (activated) carbon from fixed bed reactors is sometimes incinerated in a waste incineration plant, if the incineration plant is able to destroy and/or retain the pollutants contained. The residue of entrained bed systems can also be incinerated, if the applied adsorbent is activated carbon or oven coke only. If a mixture of other reagents and activated carbon is used, the residue is generally sent for external treatment or disposal, since there might be risks of corrosion.

2.7.2 Treatment and recycling of solid residues arising directly from the incineration process

The high mineral content of incineration residues can make them potentially suitable for use as road or other construction material. Use is possible if the material complies with a set of environmental and technical criteria. This requires an optimisation of the ash quality through primary or secondary measures. The general parameters of concern are:

- burnout;
- mineral reactivity;
- metal leaching;
- salt content;
- particle size and particle size distribution.

After suitable treatment, residues from many modern waste incineration plants fulfil the environmental and technical requirements for these quality parameters. Regulatory and political barriers are sometimes the main barriers to the use of (in particular) bottom ashes from suitably designed/operated installations.

Residue treatment methods generally aim to optimise one or more of these parameters in order to mimic the quality of primary construction materials. Due to its large production volume, lower hazardousness and leachability, treatment for recycling is mainly applied to MSW bottom ash. The use of bottom ashes from the incineration of non-hazardous wastes is promoted in the Netherlands (> 90 % used), Denmark (90 %), Germany (80 %), France (> 80%), Belgium and the UK (21 %). Bottom ashes/slugs resulting from the incineration of hazardous wastes are generally routed to hazardous waste landfilling.

Bottom ash treatment techniques are described in Section 4.7. Bottom ash can be used above ground as a building material. There are strong seasonal and regional variations in the volumes that can be used for different building applications. Bottom ash is also used underground as backfilling material to provide safe long-term support in old mine workings.

[38, Vehlow 2002], [39, Vrancken 2001], [56, UKEnvAgency 2002], [64, TWG 2003], [74, TWG 2004], [82, Germany 2014].

Fly and boiler ash treatment is performed in only a few installations in Europe. In the Netherlands, fly ash from MSWI and SSI plants is applied as filling material for road construction materials (asphalt) without any pre-treatment at the incineration plant. About a third of the total fly ash from MSWI plants and 80 % of the fly ash from SSI plants (approximately 80 000 tonnes yearly in total) has been used in this way in the Netherlands. [74, TWG 2004]. Techniques for the treatment of fly ash and boiler ash are covered in the WT BREF.

Specific processes have also been developed to make synergetic use of the residues produced by wet flue-gas cleaning processes, such as the acidic filter ash leaching process (FLUWA process), which is widely used in Switzerland. In this process, the acid of the scrubber water mobilises and extracts the heavy metals contained in the fly ashes. In a filtration stage, the low-metal filter ash cake is separated from the metalliferous filtrate phase, which is further treated with a hydrometallurgical process to separate and recover the metals contained. In the FLUREC process, cadmium, lead and copper are reductively separated and used as a secondary product in lead or copper production. Zinc, present in economically viable concentrations, is separated from the pre-cleaned filtrate by means of selective liquid-liquid extraction, and is then enriched and electrolytically recovered as high-purity zinc. Bühler and Schlumberger in [65, BAFU 2010]

Primary techniques for controlling residue outputs involve optimising control of the combustion process in order to [38, Vehlow 2002]:

- guarantee an excellent burnout of carbon compounds;
- promote the volatilisation of heavy metals such as mercury and cadmium out of the fuel bed; and
- fix lithophilic elements in the bottom ash, thus reducing their leachability.

Secondary treatment systems involve one or more of the following actions:

- size reduction, to allow metal segregation and improve technical quality;
- segregation of ferrous and non-ferrous metals, which may be recycled in the metal industry;
- separation of unburnt elements for their return to the incinerator;
- washing, in order to remove soluble salts;
- ageing (carbonation), to stabilise the matrix structure and reduce the reactivity/leachability;
- treatment with a hydraulic or hydrocarbon binder, for reuse as road base;
- thermal treatment, to render metals inert in a glassy matrix.

Both primary and secondary techniques are discussed in more detail in Section 4.7.

2.7.3 Treatments applied to flue-gas cleaning residues

The treatments that can be applied to FGC residues are described in the WT BREF.

The thermal treatment of incineration residues takes place extensively in a few countries, mainly to reduce the volume of the residues, but also to reduce their organic and heavy metal content and to improve the leaching behaviour before landfilling. Sometimes FGC residues and bottom ash are mixed together for thermal treatment. [74, TWG 2004]

The three categories of thermal treatment are vitrification, melting and sintering. The differences between these processes are chiefly related to the characteristics and properties of the final product. The flue-gas produced from thermal treatment of solid residues may contain high levels of pollutants such as NO_x , TVOC, SO_x , dust and heavy metals so appropriate flue-gas treatment is required. Sometimes the flue-gas produced is fed into the FGC system of the incinerator if it is located nearby. [74, TWG 2004]

2.8 Safety devices and measures

This section deals with safety in the sense of preventing accidents that could give rise to pollutant emissions.

[64, TWG 2003]

Plant safety is an important aspect in the planning, establishment and operation of waste incineration plants. To ensure a high level of plant safety and operational safety, the safety-relevant parts of the installation are equipped with protective systems. These are to prevent, as far as possible, the occurrence of malfunctions or accidents with the potential to cause negative effects on the environment in the vicinity of the plant, or to reduce such effects if a malfunction or accident occurs.

Safety-relevant parts of waste incineration plants and, therefore, potential sources of danger include, in particular, areas in which certain substances are present or can be formed in quantities high enough to constitute a safety concern.

These are, in particular:

- the waste bunker and other areas for the storage of potentially hazardous waste;
- the combustion and flue-gas purification plants; and
- storage facilities for necessary auxiliaries (e.g. ammonia, activated carbon).

Protective systems used to control risks include:

- systems for controlling the release of pollutants, such as retention systems for used firefighting water, bunding of tanks for substances constituting a hazard to water;
- fire protection systems and devices such as firewalls, fire detectors, fire extinguishing systems;
- systems for protection against explosions, such as pressure relief systems, bypasses, arrangements for avoiding sources of ignition, inert gas systems, earthing systems;
- systems for protection against sabotage (e.g. building security, access control and surveillance measures);
- fire dividing walls to separate the transformers and retention devices;
- fire detection and protection where low-voltage power distribution panels are located;
- pollutant detection (ammonia, gas, etc.) near corresponding storage, distribution, etc.;
- systems for protection against environmental hazards (e.g. flooding, strong winds, lightning strikes and extreme hot and cold weather).

Other plant components required for operational safety are:

- Machines and equipment designed to ensure input and output of energy (e.g. emergency power generator).
- Components for the discharge, removal or retention of hazardous substances or mixtures of hazardous substances, such as holding tanks, emergency relief and emptying systems.
- Warning, alarm and safety systems, which trigger when there is a disruption of normal operations, prevent the disruption of normal operations or restore normal operations. This includes all instrumentation and control systems of a plant. In particular, it includes all instrumentation and control systems for the various process parameters which are essential to secure normal operations, on the one hand, and which, in the event of a disturbance, bring the affected plant components to a safe condition and inform the operating personnel of the disturbance in good time, on the other.

The response of a protective device to a malfunction or an accident may cause a temporary increase in pollutant emissions. The aim of all safety measures must be to keep this time span to a minimum and to restore the safety of the plant.

[64, TWG 2003]

3 CURRENT EMISSION AND CONSUMPTION LEVELS

This chapter provides information on the current ranges of consumption and emission levels from the WI sector covering the scope of processes described in Chapter 2. The information is detailed, where considered relevant and subject to data availability, by the main types of incinerated waste that are taken into consideration. The environmental issues already described in Chapter 2 are further supported by data in this chapter, and key environmental issues are identified.

The main environmental issues for the sector are emissions to air and recovery of energy. Emissions to water are a less prominent issue.

Emission and consumption data in this chapter are mainly derived from the general data collected at individual sites in 15 Member States and in Norway and provided to support this document. Other sources of aggregated data and site-specific data were received from Member States and Industry and are also included in this chapter. Data presented in this chapter are intended to illustrate the current emission levels found in the sector, with the related consumption levels for energy and water, and including data and details on the wastes used as well as the residues produced.

For the purpose of presenting the data in a clear manner and to enable a transparent analysis, a large number of graphs and tables are included in this chapter, where the emission and consumption levels achieved by the waste incineration lines/plants that participated in the 2016 data collection are reported. In doing so, the plants or lines have been classified on the basis of the following:

Furnace type, distinguishing between:

- grate furnaces;
- rotary kilns;
- fluidised bed furnaces;
- furnaces other than the types above (e.g. liquid waste incinerators);
- gasification plants.

Waste type, where plants are classified on the basis of the prevalent type of waste (by weight) burnt in the reference year 2014, distinguishing between:

- municipal solid waste;
- sewage sludge;
- other non-hazardous waste;
- clinical waste;
- hazardous waste (for the purposes of energy recovery, in this waste category a further distinction is made between hazardous wood waste and other types of hazardous waste).

Size, distinguishing between:

- small plants: less than 100 000 tonnes/year for non-hazardous waste, or less than 48 000 tonnes/year for hazardous waste;
- medium plants: between 100 000 tonnes/year and 250 000 tonnes/year for non-hazardous waste, or between 48 000 tonnes/year and 80 000 tonnes/year for hazardous waste;
- large plants: more than 250 000 tonnes/year for non-hazardous waste, or more than 80 000 tonnes/year for hazardous waste.

Age, depending on the year when the plant/line first came into operation, distinguishing between:

- old plants, which came into operation before the year 2000;
- intermediate plants, which came into operation later than the year 2000 but before the year 2006 (publication year of the previous WI BREF); plants that were retrofitted to their current configuration before the year 2006 are also identified;
- recent plants, which came into operation later than the year 2006; plants that were retrofitted to their current configuration later than the year 2006 are also identified.

3.1 Introduction

Emissions and consumption at waste incinerators are mainly influenced by:

- waste composition and content;
- furnace technical measures (design and operation);
- design and operation of flue-gas cleaning equipment.

Emissions to air

Emissions of HCl, HF, SO₂, NO_x and metals depend mainly on the structure of the waste and the flue-gas cleaning quality. CO and VOC emissions are determined primarily by furnace technical parameters and the degree of waste heterogeneity when it reaches the combustion stage. The furnace design and operation also affect NO_x to a large extent. Dust emissions are very dependent upon the flue-gas cleaning performance. PCDD/F emissions to air depend on waste structure, furnace (temperature and residence times) and plant operating conditions (reformation and *de novo* synthesis are possible under certain conditions) and flue-gas cleaning performance.

Municipal waste incineration plants generally produce flue-gas volumes of between 4 500 m³ and 6 000 m³ per tonne of waste (calculated at 11 % oxygen) depending on the LHV of the waste. For hazardous waste incineration plants, this value (calculated at 11 % oxygen) is generally between 6 500 m³ and 10 000 m³, depending mainly on the average LHV of the waste. Plants using pyrolysis, gasification or oxygen-enriched air supply produce lower flue-gas volumes per tonne of waste incinerated.

The levels of emissions to air in this document are reported over specified averaging periods – usually yearly, daily and half-hourly averages. Some plants, particularly those that treat highly heterogeneous wastes, may experience transient conditions that give rise to instantaneous emission concentrations that are outside of the average ranges. [64, TWG 2003]

Emissions to water

Depending on the type of flue-gas cleaning applied, emissions to water may also occur. Wet flue-gas cleaning is the main source of effluents, although in some cases these effluents are also eliminated by evaporation.

Some other waste water streams may arise from storage, boilers, etc. These are described in Sections 3.3.1 and 3.3.2

Solid residues

Solid residues that may arise are:

- bottom ash or slag;
- fly ash; flue-gas cleaning residues ;waste water treatment residues.

(For more detailed descriptions see Section 2.7.1.)

[64, TWG 2003]

The production and content of these solid residues is influenced by:

- waste content and composition, e.g. different ash contents influence the amount of bottom ash arising, and the content of substances such as chlorine or sulphur will have an influence on the flue-gas cleaning residues;
- furnace design and operation, e.g. pyrolysis plants deliberately produce a char in place of the ash, and higher temperature furnaces may sinter or vitrify the ash and volatilise some fractions;
- flue-gas cleaning design and operation, e.g. some systems separate dust from chemical residues, and wet systems produce an effluent from which solids are extracted after treatment.

Energy output from the installation

The major influences on the achieved export levels are:

- availability of an energy user (particularly for heat/steam supply);
- installation design (particularly for electrical output where the steam parameters chosen for electricity generation have a significant influence on electricity generation rates).

The energy output system design adopted is often heavily influenced by the income to be derived from the sales of the energy supplied. Relative and absolute prices of heat, steam and electricity all have an influence on the final design and hence the energy output and efficiency levels achieved.

Energy consumption of the installation itself

The main influences are as follows:

- The waste composition - some wastes require the use of a support fuel (waste or non-waste) to ensure complete combustion while others are auto-thermal, i.e. they generate sufficient heat to support the combustion without additional support fuel input.
- The design of the installation, e.g. varying energy requirements of different flue-gas cleaning equipment designs. In general, the lower the required emissions to air the higher the energy consumption of the FGC system.

Other consumption

The consumption of chemical reagents is mainly associated with the design and operation of flue-gas cleaning equipment – which, to a large degree, is dependent upon the waste type and the desired air emission levels – lower emissions to air generally require higher reagent dosing rates.

3.1.1 Substance partitioning in the waste incineration outlet streams

As a result of their chemical properties, the different elements contained in the waste are distributed differently in the outlet streams of the incineration process. Table 3.1 gives an example of this distribution on the basis of Austrian studies at the waste incineration plant of Spittelau, Vienna. [1, UBA 2001]

This distribution varies from plant to plant, depending on the flue-gas cleaning method used, waste type and other factors, but these figures provide a guide to the percentage distribution of various substances in the outlet streams of a MSWI. The installation concerned uses an ESP as a pre-deduster, before wet FGC, with a WWTP treating the scrubber effluent.

Table 3.1: Distribution of various substances in the outlet streams of an example MSWI installation (in mass %)

Substance	Cleaned flue-gas discharge	ESP dust	Waste water	Sludge from waste water treatment	Bottom ash ⁽¹⁾ ⁽²⁾
Carbon (%)	98 (+/-2)	< 1	< 1	< 1	1.5 (+/-0.2)
Chlorine (%)	< 1	35	54	< 1	11
Fluorine (%)	< 1	15 (+/-1)	<1	< 1	84 (+/-1)
Sulphur (%)	< 1	38 (+/-6)	8 (+/-1)	6 (+/-1)	47 (+/-7)
Phosphorus (%)	< 1	17 (+/-1)	< 1	< 1	83 (+/-1)
Iron ⁽³⁾ (%)	< 1	1 (+/-0.5)	< 1	< 1	18 (+/-2)
Copper (%)	< 1	6 (+/-1)	< 1	< 1	94 (+/-1)
Lead (%)	< 1	28 (+/-5)	< 1	< 1	72 (+/-5)
Zinc (%)	< 1	54 (+/-3)	< 1	< 1	46 (+/-3)
Cadmium (%)	< 1	90 (+/-2)	< 1	< 1	9 (+/-1)
Mercury (%)	< 1	30 (+/-3)	< 1	65 (+/-5)	5 (+/-1)

⁽¹⁾ The bio-availability of materials that remain in the bottom ash depends on leachability in situ during subsequent use/disposal.
⁽²⁾ The risk associated with the reuse of bottom ash is not necessarily indicated by the presence or absence of the substances indicated – the chemical and physical form of the substance as well as the nature of the environment where the material will be used are also important. [64, TWG 2003]
⁽³⁾ The remaining approx. 80 % is sorted out as scrap.
Source: [1, UBA 2001], [64, TWG 2003]

Additional differences result from different contents of waste, especially in the case of hazardous waste incineration facilities.

Table 3.2 gives the percentage distribution of six metals, mercury, cadmium, arsenic, lead, copper and zinc, averaged over a test period in the outlet streams of a HWI. The table also gives the mass fraction of the following solid residues: slag, fly ash and sludge, related to the amount of waste incinerated during the test.

Table 3.2: Percentage (%) distribution of metals in the outlet streams of a hazardous waste incineration process

Heavy metal	Solid residues for disposal				Act. carbon	Release to environment		
	Slag	Fly ash	WWT Sludge	Sum		To air	Water effluent	Sum
% Mass fraction	30	3	4					
Hg	< 0.01	< 0.01	99.88	99.88	0.05	< 0.01	0.07	0.07
Cd	1.3	94.2	4.49	99.99	< 0.01	< 0.01	< 0.01	< 0.01
As	14.6	80.0	5.39	99.99	< 0.01	< 0.01	< 0.01	< 0.01
Pb	41.2	56.0	2.75	99.95	< 0.01	0.03	0.02	0.05
Cu	75.9	22.4	1.69	99.99	< 0.01	< 0.01	0.01	0.01
Zn	41.9	56.9	1.17	99.97	< 0.01	0.01	0.02	0.03

Source: [41, EURITS 2002]

The most important parameters that influence the behaviour of metals are:

- kiln temperature;
- O₂ excess in the kiln;
- the chlorine and sulphur contents of the waste; and
- the mass transfer of fine particles in the flue-gas.

The average conditions during the tests on a HWI that gave rise to the data in Table 3.2 are given below in Table 3.3.

Table 3.3: Average operating conditions during partitioning tests on a HWI installation

Parameter	Test data
Kiln temperature	1 120 ± 40 °C
PCC temperature	1 100 ± 20 °C
Oxygen content (in the kiln)	11.9 ± 1.3 %
Cl content (in the waste)	5.1 ± 1.0 %
S content (in the waste)	1.0 ± 0.2 %
<i>Source: [41, EURITS 2002]</i>	

From Table 3.2, the following observations regarding the metals studied can be made:

- about 99.6 % of the pollutants are concentrated in the solid residues;
- about 70–80 % of the pollutants are concentrated and immobilised in the fly ash and WWT sludge fraction; both residues amount in weight to approximately 5.5 % of the original waste input;
- the removal of mercury from the flue-gas is (in this case) mainly the result of the low pH of the first flue-gas cleaning stage.

Bottom ash and fly ash from mono-incineration of sewage sludge (i.e. incineration of sewage sludge alone, not mixed with wastes containing low levels of phosphorus such as municipal solid waste or industrial sludges) contain 7-11% phosphorus, and recovery is feasible to produce e.g. industrial phosphorus chemicals (such as phosphoric acid) or fertilisers. [139, Kleemann et al. 2017], [140, Biswas et al. 2009], [141, Egle et al. 2016], [142, Amann et al. 2018]

3.1.2 Examples of dioxin balance for MSWI

PCDD/F are contained in the input (municipal waste) as well as the output (outgoing air, waste water and residues) of municipal waste incineration plants. Most of the PCDD/F input is destroyed during the incineration process, but PCDD/F can also be reformed. [1, UBA 2001]

The balance below is for a typical plant in Germany, operating free of process water releases and complying with German emission limit values.

Table 3.4: PCDD/F balance for a municipal waste incineration plant in Germany

Output streams	Amount per kg of waste input	Specific load	Stream-specific load per kg of waste input
Flue-gas	6.0 m ³	0.08 ng/m ³	0.48 ng/kg
Bottom ash	0.25 kg	7.0 ng/kg	1.75 ng/kg
Filter dust and other residues from flue-gas cleaning	0.07 kg	220 ng/kg	15.40 ng/kg
Total output to all media:	17.63 ng TEQ/kg of waste		
NB: Estimated input with the waste: 50 ng TEQ/kg of waste.			
<i>Source: [1, UBA 2001], [64, TWG 2003]</i>			

From Table 3.4 above it can be seen that, for the example given, the estimated output released to air is approximately 1 % of the input (0.48 ng TEQ/kg out of 50 ng TEQ/kg). The estimated output released to all media is 17.63 ng TEQ/kg of incoming waste. This corresponds to 35.3 %

of the estimated input (i.e. a net destruction of 64.7 % of the PCDD/F originally contained in the waste). It can therefore be concluded that, in this case, the installation acts as a net sink for PCDD/F. [64, TWG 2003]

The following data are from an example MSWI (in France) that discharges to water.

Table 3.5: Example PCDD/F load data for an MSWI in France

Output stream	Specific load
Flue-gas	0.1 ng I-TEQ/Nm ³
Bottom ash	7 ng I-TEQ/kg
FGC residues	5 200 ng I-TEQ/kg
Waste water	< 0.3 ng I-TEQ/l
NB: Example for a MSWI fitted with ESP + wet scrubber (2-stage) + SCR. Source: [64, TWG 2003]	

3.1.3 Composition of raw flue-gas in waste incineration plants

The composition of raw flue-gas in waste incineration plants depends on the structure of the waste and on furnace technical parameters.

Table 3.6 provides an overview of the typical raw flue-gas composition after the boiler and before the flue-gas treatment.

Table 3.6: Flue-gas concentrations after the boiler (raw flue-gas) at various waste incineration plants (O₂ reference value 11 %)

Components	Units	Incineration plants for		
		Municipal waste	Hazardous waste	Industrial sewage sludge (fluidised bed)
Dust	mg/Nm ³	1 000–5 000	1 000–10 000	30 000–200 000
Carbon monoxide (CO)	mg/Nm ³	5–50	< 30	5–50
TOC	mg/Nm ³	1–10	1–10	1–10
PCDD/F	ng TEQ/Nm ³	0.5–10	0.5–10	0.1–10
Mercury	mg/Nm ³	0.05–0.5	0.05–3	0.2
Cadmium + thallium	mg/Nm ³	< 3	< 5	2.5
Other heavy metals (Pb, Sb, As, Cr, Co, Cu, Mn, Ni, V, Sn)	mg/Nm ³	< 50	<100	800
Inorganic chlorine compounds (as HCl)	mg/Nm ³	500–2 000	3 000–100 000	NI
Inorganic fluorine compounds (as HF)	mg/Nm ³	5–20	50–1 000	NI
Sulphur compounds, total of SO ₂ /SO ₃ , counted as SO ₂	mg/Nm ³	200–1 000	1 500–50 000	NI
Nitrogen oxides, counted as NO ₂	mg/Nm ³	150–500	100–1500	< 200
Nitrous oxide	mg/Nm ³	< 40	< 20	10–150
CO ₂	%	5–10	5–9	NI
Water steam (H ₂ O)	%	10–20	6–20	NI
NB: Sewage sludge plants are those for the incineration of industrial sewage sludge. This information refers to German plants. The values seen at older plants can be considerably higher, especially in the case of emissions influenced by furnace technical parameters, e.g. CO, TOC. Hazardous waste values refer to mixed HW merchant plants rather than dedicated stream plants. NI = No information provided. Source: [1, UBA 2001], [64, TWG 2003], Austria's and HWE Comments in [7, TWG 2017]				

Municipal waste

In the case of municipal waste, the structure depends, among other things, on the systems used for the collection of different waste fractions and on the use or absence of pre-treatment. For example, the separate collection of different municipal waste fractions can influence the thermal value of municipal waste in the following way:

- glass and metal - reduction of the ash content, resulting in an increase in the calorific value;
- paper - reduction of the calorific value;
- light packaging - reduction of the calorific value;
- clinical/hospital waste - increase of the calorific value;
- organic waste - increase of the calorific value.

Parameters such as the chlorine content and heavy metals content are also affected, but the changes remain within the typical range of variations. However, the separate collection of certain specific items such as some batteries or dental amalgam can significantly reduce mercury inputs to the incineration plant. [64, TWG 2003]

Commercial non-hazardous waste

In the case of non-hazardous waste from commercial enterprises, the ranges of variations can be considerably greater than MSW. When incinerated with other MSW, mixing in the bunker and shredding may be used to limit these variations.

Hazardous waste

The composition of hazardous waste may vary within a considerably greater range. In the case of hazardous waste, fluorine, bromine, iodine and silicon can be significant. Unlike municipal waste, however, the structure of hazardous waste is usually verified at the incineration plants by means of a check analysis of all essential parameters. Due to the possible variations, a hazardous waste incineration plant is designed with regard to an average waste structure (menu), in some cases with considerable additional reserves for flue-gas cleaning.

Such an incineration menu can then be created by intentionally mixing the incoming waste in bulk tanks or the bunker, or by individually feeding the waste to the furnace in separate pipes in hourly amounts corresponding to the design of the plant. This is also to be taken into account if waste is fed in barrels, which can themselves exert sudden shock loads. Incineration plants specifically designed for recovering HCl and SO₂ from waste streams containing chlorine or sulphur, respectively, may have very different raw gas structures.

Sewage sludge

Variations in the raw gas at sewage sludge incineration plants correspond to changes in the waste composition of the incinerated waste. This, in turn, is influenced by the presence or absence of pre-treatment, and the composition of the sludge received. The composition of sewage sludge is strongly dependent upon the nature of the drainage catchment served by the sewage treatment works where the sludge arises and the treatments applied there.

[64, TWG 2003]

Where sewage sludge is incinerated with other wastes, variations in sewage sludge quality may have a less pronounced effect on raw gas quality owing to the buffering effect of the other wastes. The water content of the sewage sludge may indeed provide benefits at some MSWI installations as, when sprayed through special nozzles in selected locations above the waste bed (often in the gas burnout zone), it provides an additional means of controlling temperature and may assist with primary NO_x control.

Clinical waste

Variations in the raw gas at clinical incineration plants correspond mainly to changes in the waste composition of the incinerated waste. Physical pre-treatments that may limit the range of variation of raw gas composition are not often used for clinical wastes because of concerns regarding the infectivity of the waste.

Categorising incoming waste streams according to their source and probable combustion characteristics (mainly relating to CV, moisture content and calorimetric throughput rate), and feeding them to the incineration process so as to comply with an appropriate input *recipe*, may be used to reduce the range of combustion-related raw gas composition variations.

[64, TWG 2003]

3.2 Emissions to air

3.2.1 Substances emitted to air

[1, UBA 2001] [64, TWG 2003]

Carbon monoxide

CO is an odourless toxic gas. Carbon monoxide (CO) in the flue-gas of incineration plants is the product of the incomplete combustion of carbon-based compounds. CO is produced when there is insufficient oxygen locally and/or an insufficiently high temperature of combustion to carry out full oxidation to carbon dioxide. In particular, this can occur if spontaneously evaporating or rapid-burning substances are present, or when combustion gas mixing with the supplied oxygen is poor. Continuous measurement of the CO level can be used to check the efficiency of the incineration process. CO is a measure of the quality of combustion. If the CO emissions are very low then the gas burnout quality is very high and TVOC emissions are also low (and vice versa). [74, TWG 2004]

After its release to the atmosphere, CO is oxidised to CO₂, after some time. Particularly high concentrations of CO (above the lower explosive limit) must be avoided as they can create explosive mixtures in the flue-gas. In particular, at hazardous waste incineration plants, increased CO emissions can occur with some drummed wastes.

CO is measured continuously.

It is reported that NO_x treatment with SCR may increase CO emission levels. [74, TWG 2004]

Total volatile organic carbon (TVOC)

This parameter includes a number of gaseous organic substances, the individual detection of which is generally complex or not possible. During the incineration of organic waste, a large number of chemical reactions take place, some of which are incomplete. This leads to an extremely complex pattern of compounds in trace amounts. A complete account of every substance within the TVOC parameter is not available; however, incineration generally provides high destruction efficiencies for organic substances.

TVOC is measured continuously. Low TVOC levels are key indicators for the quality of combustion in an incineration process.

Hydrogen chloride

Many wastes contain chlorinated organic compounds or chlorides. In municipal waste, typically approximately 50 % of the chlorides come from PVC [64, TWG 2003]. In the incineration process, the organic component of these compounds is destroyed and the chlorine is converted to HCl. Part of the HCl may react further with inorganic compounds which are also contained in the waste to form metal chlorides.

HCl is highly soluble in water and has an impact on plant growth. It is measured continuously.

The formation and emission of Cl₂ is of minor importance under normal incineration conditions. However, it is essential for fouling and corrosion. So it is worth controlling the formation so that the process mentioned takes place in the gas phase and not after deposition on boiler tubes. [74, TWG 2004]

Hydrogen fluoride

The HF formation mechanism in incineration plants is analogous to that of HCl. The main sources of HF emissions in municipal waste incineration plants are probably fluorinated plastic or fluorinated textiles and, in individual cases, the decomposition of CaF₂ in the course of the incineration of sludge.

HF is highly soluble in water and can have an impact on plant growth. It is measured continuously or discontinuously.

Various kinds of fluorinated waste are treated in hazardous waste incineration plants.

Hydrogen iodide and iodine, hydrogen bromide and bromine

Municipal waste usually contains very small quantities of bromine or iodine compounds. Bromine or iodine emissions are, therefore, of minor importance to municipal waste incineration plants.

In hazardous waste incineration plants, organic and inorganic wastes containing bromine or iodine are sometimes treated. For example, bromine compounds are used as flame retardants in plastic and textile applications and can be found in some electric and electronic waste; they are also used in the chemical industry as alkylation reagents. Iodine can be contained in medicines. On the whole, however, the quantity of these compounds is small in relation to chlorinated compounds. Bromine and iodine help to oxidise mercury and decrease the mercury content in the clean gas by improving the retention capacity of wet scrubbers. [74, TWG 2004]

Where present, the chemical properties of elementary iodine and bromine can result in colouration of chimney plumes. Special measures can be taken for the incineration of such waste in order to prevent the formation and release of elemental bromine or iodine. These substances can also have toxic and irritant effects. [64, TWG 2003]

Sulphur oxides

If the waste contains sulphur compounds, mainly SO₂ will be created during the incineration of the waste. Under appropriate reaction conditions, SO₃ can also be created. For MSW, the proportion of SO₃ can be around 5 % at the inlet to the FGC (the SO₃ content is important to determine the acid dew point). Common sources of sulphur in some waste streams are: waste paper, plasterboard (calcium sulphate), and sewage sludges. [64, TWG 2003]

SO₂ causes acidification and is a precursor of secondary aerosols. It is measured continuously.

Nitrogen oxides

Various oxides of nitrogen are emitted from incineration plants and, in many cases, they are measured using continuous emission monitors. Oxides of nitrogen can have toxic and global warming effects, cause acidification and eutrophication, and form secondary aerosols depending on the oxide concerned.

The NO and NO₂ emitted from waste incineration plants originate from the conversion of the nitrogen contained in the waste (so-called fuel NO_x) and from the conversion of atmospheric nitrogen from the combustion air into nitrogen oxides (thermal NO_x). Production of thermal NO_x generally becomes more significant at temperatures above 1 000 °C, so in MSWI the proportion of thermal NO_x is usually very low due to the lower temperatures in the afterburner chamber. In MSWI, the amount of thermal NO_x can also be critically dependent on the quantity, and manner, of injection of secondary air into the afterburner chamber – with higher NO_x seen with higher nozzle temperatures (i.e. above 1 400 °C).

The mechanisms for the formation of NO_x from the nitrogen contained in the waste are very complicated. Amongst other reasons, this is because nitrogen can be contained in the waste in many different forms, which, depending on the chemical environment, can react either to NO_x or to elementary nitrogen. A conversion rate of approximately 10–20 % of the fuel nitrogen is usually assumed depending on the waste type. High chlorine and sulphur concentrations, O₂ content and temperature may have a significant influence. The proportion of NO/NO₂ in the total NO_x stack emissions is usually about 95 % NO and 5 % NO₂.

Nitrous oxide (N₂O) is not usually measured as a part of the NO_x estimation. It can be emitted if the temperature is insufficient for complete combustion (e.g. less than 850 °C) and there is

insufficient oxygen. The N_2O emissions from incineration processes are, therefore, often correlated with CO emissions.

Where SNCR is applied for de- NO_x , the formation of N_2O may increase, dependent upon reagent dose rates and temperature. Values of 20–60 mg/m^3 have been measured where higher SNCR dose rates are used to achieve lower NO_x emission levels, in particular when urea is used as the reagent, rather than ammonia.

For municipal waste incineration, N_2O emissions of 1–12 mg/Nm^3 (for individual measurements) and averages of 1–2 mg/Nm^3 are seen. For the incineration of MSW in fluidised bed plants, the measured N_2O emission values (individual measurements) are usually higher.

Individual measurements in hazardous waste incineration plants have resulted in N_2O emission values of 30–32 mg/Nm^3 . [64, TWG 2003]

Normal N_2O emission levels for fluidised bed sludge incineration can be as low as 10 mg/Nm^3 . Sewage sludge incineration can have higher N_2O emission levels depending on the concentration of nitrogen in the sludge. The level of N_2O can be decreased with a higher incineration temperature, but the highest possible flue-gas temperature depends on the fly ash melting temperature.

Whilst these releases add to the global warming impact, incineration is a minor contributor of anthropogenic emissions of nitrous oxide.

NO_x is measured continuously.

Dust

Dust emissions from waste incineration plants mainly consist of the fine ash from the incineration process that is entrained in the gas flow. Depending on the reaction balance, other elements and compounds are concentrated in this airborne dust. The separation of dust from the flue-gas using flue-gas cleaning devices removes the majority of the dust and entrained inorganic and organic substances (e.g. metal chlorides, PCDD/F).

Flue-gas cleaning equipment greatly reduces emissions of total dust from waste incineration plants. In common with all combustion processes, the type of flue-gas cleaning equipment used affects the particle size distribution of the emitted dust. The filtration equipment is generally more effective on the larger particles, and therefore changes the proportion of finer particulate in the resulting emissions to air, whilst reducing the total particulate emission.

Dust is measured continuously.

Mercury and mercury compounds

Mercury can currently still be found in municipal waste, notably in the form of batteries, thermometers, dental amalgam, fluorescent tubes or mercury switches. Separate collection of these can help reduce overall loads in mixed MSW but collection rates of 100 % are not achieved in practice.

Mercury is a highly toxic metal. Without an adequate flue-gas cleaning system, the incineration of mercury-containing wastes can give rise to significant emissions.

Mercury emissions are measured continuously or periodically (in some cases using also long-term sampling [80, Denmark 2015]).

In hazardous waste incineration, there are several specific streams that may contain increased concentrations of mercury in the received waste:

- tars from coking plants;
- waste from chlor-alkali electrolysis (mercury cell process);
- caustic oil sludge from refineries;
- chemicals containing mercury.

The form of the mercury emissions depends largely on the chemical environment in the flue-gas. A balance between elemental mercury (Hg^0) and HgCl_2 normally develops. Where there is a sufficiently high concentration of HCl in the flue-gas (in relation to the reduction agent SO_2), mercury will mainly be contained in the flue-gas as HgCl_2 . This can be separated from the flue-gas significantly more easily than elemental mercury. If, however, HCl is contained in the flue-gas at lower concentrations (e.g. in sewage sludge incineration plants), mercury exists in the flue-gas mainly in elemental form and is then more difficult to control. The combustion temperature also influences HgCl_2 formation.

In wet scrubbers (only), the HgCl_2 removed can be reduced if SO_2 is also present (the separation of these substances is one reason why distinct wet scrubber stages are operated for the removal of HgCl_2 and SO_2). The Hg_2Cl_2 formed when this happens can in turn undergo disproportionation into HgCl_2 and elemental Hg . These reactions can be prevented by adjusting the pH in wet scrubbers to low values and by removing mercury from the scrubber effluent.

Elemental mercury is virtually insoluble in water ($59 \mu\text{g/l}$ at 25°C). Mercuric (II) chloride is much more soluble at 73 g/l . Mercury (II) chloride can therefore be separated in wet scrubbers, whereas the separation of metallic mercury requires further flue-gas treatment stages (see Section 2.5.6 for further details). [64, TWG 2003]

Cadmium and thallium compounds

Common sources of cadmium in municipal waste incineration plants are electronic devices (including accumulators), batteries, some paints and cadmium-stabilised plastic. Thallium is virtually non-existent in municipal waste.

Hazardous wastes may contain high concentrations of cadmium and thallium compounds. Effluent treatment sludges and drummed wastes from metal plating and treatment may be significant sources.

Cadmium is highly toxic and can accumulate in the soil.

Cadmium and thallium emissions are measured periodically.

Other metal compounds

This comprises the metals antimony, arsenic, lead, chromium, cobalt, copper, manganese, nickel, vanadium, tin and their respective compounds. European and many national regulations thus group them together for emission measurement requirements. This group contains carcinogenic metals and metal compounds such as arsenic and chromium (VI) compounds, as well as metals with toxicity potential.

The retention of these metals depends largely on an effective separation of dust as they are bound in dust due to the vapour pressures of their compounds, as contained in the flue-gas (mainly oxides and chlorides).

Metal emissions are measured periodically.

Polychlorinated biphenyls

Low quantities of polychlorinated biphenyls (PCBs) are found in most municipal waste streams and also in some industrial wastes. Wastes with large proportions of PCBs, however, generally only arise from specific PCB collection and destruction programmes, when concentrations of PCBs in such waste can be very high.

In hazardous waste incineration plants, wastes with a PCB content as high as 60–100 % are combusted. The same applies to special plants for the incineration of highly chlorinated hydrocarbons. PCBs are more efficiently destroyed if higher incineration temperatures are used (e.g. above 1 200 °C). PCBs contained in the crude flue-gas of waste incineration plants can be the result of incomplete destruction.

PCB emissions are classified as potentially toxic by some international organisations (e.g. WHO). A toxicity potential (similar to that of dioxins and furans) is ascribed to some of the PCBs (coplanar PCBs).

Polyaromatic hydrocarbons

Polyaromatic hydrocarbons are well known as products of incomplete combustion. They are toxic and have carcinogenic and mutagenic properties. [74, TWG 2004]

Polychlorinated dibenzo-dioxins and furans (PCDD/F)

Dioxins and furans (PCDD/F) are a group of compounds, some of which are extremely toxic and are considered to be carcinogens. Their production and release is not specific to waste incineration but occurs in all thermal processes under certain process conditions.

Significant advances in PCDD/F emission control have been achieved in the WI sector. Improvements in the design and operation of combustion and flue-gas cleaning systems have resulted in plants that can reliably achieve very low emission limit values.

[64, TWG 2003] In well-designed and -operated incineration plants, material balances have shown that incineration effectively removes PCDD/F from the environment (see Section 3.1.2).

The dioxin balance is made most favourable by ensuring that:

- input dioxins and precursors are effectively destroyed using appropriate combustion conditions;
- the use of conditions that may give rise to PCDD/F formation and reformation including *de novo* synthesis is reduced.

PCDD/F entering the process with the waste are destroyed very efficiently if sufficiently high incineration temperatures and appropriate process conditions are used. The PCDD/F found in the crude flue-gas of waste incineration plants are the result of recombination reactions of carbon, oxygen and chlorine. Suitable precursor substances (e.g. from chlorophenols) can also react to form dioxins and furans. Some transition metal compounds (e.g. copper compounds) can act as catalysts for the reformation of PCDD/F.

PCDD/F can be formed during start-up operations even when waste is not burnt due to poor combustion. In the cold start-up the furnace temperature is raised slowly and when the furnace temperature is low soot can form. The soot adheres to the furnace and the boiler. *De novo* synthesis of PCDD/F occurs especially in the temperature range between 250 °C and 350 °C when sufficient carbon and chlorine in the form of inorganic chloride is available. During a cold start-up, the furnace and boiler surfaces that are in the temperature range that can promote PCDD/F formation through *de novo* synthesis are much bigger than when the incineration plant is working in stable conditions, possibly resulting in PCDD/F emission loads equivalent to several months of normal operation being associated to a single cold start [79, Gass et al. 2002]. Also, due to the possible accumulation of PCDD/F in the flue-gas cleaning devices occurring

during shutdown, some specific studies have highlighted PCDD/F emissions substantially higher than in stable conditions during prolonged periods of time (weeks) after a cold start [79, Gass et al. 2002] [83, Dehoust et al. 2005] [114, Wilken et al. 2003]. Techniques for the prevention or minimisation of PCDD/F emissions at cold start have been developed over the years and are briefly described in Section 4.5.5.2.

PCDD/F emissions are monitored periodically, using short-term and also long-term sampling.

Polybrominated dibenzo-dioxins and furans (PBDD/F)

While bromine is less common than chlorine in waste, it acts in a similar way to chlorine during combustion to form brominated dioxins and furans. The presence of both bromine and chlorine results in the formation of mixed bromo-chloro dioxins and furans. The ratio of bromine and chlorine in the combustion process largely corresponds to the ratio of bromine and chlorine in the dioxin and furan molecules formed. [47, TWG 2018]

One of the most noticeable PBDD/F occurrences is their presence as impurities in commercial mixtures of brominated flame retardants (BFRs), such as polybrominated diphenylethers (PBDE), and their subsequent occurrence in household products and house dust.

During insufficiently controlled combustion processes, significant amounts of PBDD and PBDF may be formed, including those with the most toxic dioxin-like properties. The origin of these PBDF may partly be explained by their presence as contaminants in the commercial PBDE flame-retardant mixtures in household waste, but *de novo* synthesis cannot be excluded. Another source of bromine in incineration processes is the use of techniques for the enhanced oxidation of mercury (thereby enabling efficient mercury removal in the downstream FGC system) by means of high-temperature bromide injection. [116, van den Berg et al. 2013]

Ammonia

Ammonia has a significant impact on eutrophication and acidification of the environment. Ammonia emissions can arise from the overdosing or poor control of NO_x reduction reagents that are used for NO_x control.

Carbon dioxide

For every tonne of municipal waste combusted, approximately 0.7–1.7 tonnes of CO₂ are generated.

Because municipal waste is a heterogeneous mixture of biomass and fossil material, the portion of CO₂ from MSWIs of fossil origin (e.g. plastic) which is considered relevant to climate change is generally in the range of 33 % to 50 %.

Methane

It can be assumed that, if combustion is carried out under oxidative conditions, methane levels in the flue-gas will be almost zero. Methane is measured among the TVOC components. [64, TWG 2003]

Methane can also be created in the waste bunker if there are low oxygen levels and subsequent anaerobic processes in the waste bunker. This is only the case where wastes are stored for long periods and not well agitated. Where the storage area gases are fed to the incineration chamber air supply, they will be incinerated and emissions will be reduced to insignificant levels.

3.2.2 Emissions to air from waste incineration plants

This section presents the range of emissions achieved by the waste incineration plants that participated in the 2016 data collection for the review of the WI BREF.

An exceptional data collection supported this exercise. It covered the emissions measured at 355 individual monitored points of emissions throughout an entire year, in the case of continuously monitored emissions to air with a half-hourly time resolution.

For each monitored point of emissions to air, the entire series of 17 520 half-hourly average concentrations in the year 2014 was collected for each of the pollutants subject to continuous monitoring, along with key operating parameters such as flow rate, furnace temperature, input of waste and of support fuel.

Plant operators also complemented these data by identifying as far as possible the conditions in which the plant was operating during each of the half-hourly periods, such as when no waste was being burnt, when (part of) the abatement system was being bypassed, when a stoppage, breakdown or malfunction occurred, or when the plant was in a start-up or shutdown situation.

These complete series of emission levels reported as half-hourly averages were then used as the basis for the determination of emission levels expressed for different averaging periods (mainly as daily averages). This allowed a detailed analysis of the influence of including or excluding different categories of operating conditions when determining the emission levels representative of the performance of the plant expressed with different averaging periods, in a transparent and traceable manner.

In total, the data set summarised in this chapter comprises close to 100 million individual average values provided by the plant operators.

The collection and analysis of a data set of such a size of course poses considerable challenges. Operators were asked to painstakingly retrieve and identify the operating conditions of the plant throughout an entire year on the basis of the control room logs, and this is naturally prone to limitations and errors.

A further point of attention is associated with the emission levels reported by the plants, which in many cases are very low, and in some cases close to the limits of quantification or detection of the standard reference methods, or in ranges where the uncertainty associated with the calibration of the automated measurement system may be high in relative terms. For these aspects the reader is referred to the JRC Reference Report on Monitoring of Emissions to Air and Water in IED installations [117, COM 2018], in particular to its Section 3.4.4 and to the references therein, including in particular [118, INERIS 2016]. [121, INERIS 2017] is an updated version of the latter report.

In the graphs presented in Annex 8.6, Annex 8.7 and Annex 8.8 (and summarised in this chapter), a single data point refers to a monitored point of release for emissions to air (reference line), and may refer to either one or a group of individual incineration lines. All reference lines, along with some of their key characteristics, are listed in Annex 8.4.

Emission data are presented in graphs alongside the techniques and, where relevant, the type of reagents in use in each of the reference lines, as well as additional complementary information, such as the age and size of each reference line. A separate graph is presented for each pollutant, and the accompanying selection of techniques is adapted to the pollutant addressed (e.g. the use of SCR and SNCR is shown in the graph on NO_x and NH₃ emissions, while the use of ESP and bag filter is shown in the graph on dust emissions).

Emission data are presented as follows:

- Annex 8.6 shows, individually for each of the reference lines that participated in the 2016 data collection and reported continuously measured emissions, the daily emission levels and the relevant techniques in place.
- Annex 8.7 shows, individually for each of the reference lines that participated in the 2016 data collection and reported continuously measured emissions, the half-hourly emission levels and the relevant techniques in place.
- Annex 8.8 shows, individually for each of the reference lines that participated in the 2016 data collection and reported periodically measured emissions, the emission levels and the relevant techniques in place.
- This chapter includes simplified graphs, based on the more detailed graphs of the annexes above, showing the distribution of emission levels achieved as well as an indication of the most relevant techniques or plant characteristics that may have a significant influence on the emission levels.

A more detailed reading key to each of these graph types follows in the remainder of this section.

For continuously monitored data: daily emission levels

The graphs in Annex 8.6 show emissions as yearly averages and as yearly maxima of daily averages calculated on the basis of the reported 17 520 half-hourly averages measured in 2014 and obtained using a 'base' and a 'fine' data filtering option. Data filtering is used to exclude from a daily average the emissions measured during half-hourly periods that are associated with some specific operating conditions. In particular:

- The 'base' data filter excludes the emissions measured when:
 - the furnace temperature is below the minimum incineration temperature required, and/or the measured flow rate is very low;
 - the plant is undergoing maintenance, in breakdown, or in stoppage;
 - the plant is only combusting support fuels (preheating before the first waste is introduced into the furnace or shutdown operation after the last of the waste remaining in the furnace has been incinerated);
 - the automated monitoring system is undergoing maintenance or malfunctioning.
- Additionally, the 'fine' data filter also excludes the emissions measured when:
 - the plant is in start-up while waste is already being incinerated, or in shutdown while waste is still being incinerated;
 - the abatement system is being bypassed;
 - there is a failure, malfunction or leak in the abatement system or in the process;
 - one of the half-hourly ELVs established in the plant's permit is being exceeded;
 - other exceptional conditions reported by the plant operator.

Furthermore, with the 'fine' data filter the daily average is discounted when more than 5 half-hourly periods are filtered out by any of the conditions above.

It should be noted that the data filtering relies on detailed information reported by the plant operators according to a harmonised questionnaire that included a common definition of operating conditions that may differ from the level of detail and form of the information recorded in the log files of the plant operators. The challenges for the operators to report this information accurately and to a high level of detail are fully acknowledged, and, where certain information was missing or inaccurately reported, may result in data that are not fully comparable across plants.

The graphs also report the daily ELV in the permit of each plant and, where relevant, the amount of reagent used per tonne of waste incinerated; in the case of alkaline reagents the amount is normalised to a quicklime-weight equivalent by stoichiometry.

All emission data are corrected for standard pressure and temperature conditions and normalised for a reference oxygen level of 11 %, but otherwise are presented as measured, without adding or subtracting the measurement uncertainty or taking into account the specific rules applied for compliance.

For continuously monitored data: half-hourly emission levels

The graphs in Annex 8.7 show emissions as yearly maxima of the reported 17 520 half-hourly averages measured in 2014 after filtering using either the 'base' or the 'fine' data filtering option, as well as the 97th percentile of half-hourly averages filtered only with the 'base' data filtering option. Data filtering is used to exclude from the data series the emissions measured during half-hourly periods that are associated with some specific operating conditions. In particular:

- The 'base' data filter excludes the emissions measured when:
 - the furnace temperature is below the minimum incineration temperature required, and/or the measured flow rate is very low;
 - the plant is undergoing maintenance, in breakdown, or in stoppage;
 - the plant is only combusting support fuels (preheating before the first waste is introduced into the furnace or shutdown operation after the last of the waste remaining in the furnace has been incinerated);
 - the automated monitoring system is undergoing maintenance or malfunctioning.
- Additionally, the 'fine' data filter also excludes the emissions measured when:
 - the plant is in start-up while waste is already being incinerated, or in shutdown while waste is still being incinerated;
 - the abatement system is being bypassed;
 - there is a failure, malfunction or leak in the abatement system or in the process;
 - other exceptional conditions reported by the plant operator.

Furthermore, with the 'fine' data filter the half-hourly periods corresponding to the 60 highest half-hourly emission levels reported in the year for each pollutant are discounted. The combination of the 'fine' and 'base' data filters thus gives some basic information on the distribution of the measured half-hourly emission levels around the maximum values.

It should be noted that the data filtering relies on detailed information reported by the plant operators according to a harmonised questionnaire that included a common definition of operating conditions that may differ from the level of detail and form of the information recorded in the log files of the plant operators. The challenges for the operators to report this information accurately and to a high level of detail are fully acknowledged, and, where certain information was missing or inaccurately reported, may result in data that are not fully comparable across plants.

The graphs also report the half-hourly ELV in the permit of each plant and, where relevant, the amount of reagent used per tonne of waste incinerated; in the case of alkaline reagents the amount is normalised to a quicklime-weight equivalent by stoichiometry.

All emission data are corrected for standard pressure and temperature conditions and normalised for a reference oxygen level of 11 %, but otherwise are presented as measured, without adding or subtracting the measurement uncertainty or taking into account the specific rules applied for compliance.

For periodically monitored data

The graphs in Annex 8.8 show the following data points for emission levels:

- maximum emission level among all the data reported;
- maximum emission level among the measurements taken with long sampling period;
- maximum emission level among the reported 2014 data that do not exceed the ELV set in the permit;
- average of all the reported emission levels.

The graphs also report the daily ELV in the permit of each plant and, where relevant, the amount of reagent used per tonne of waste incinerated; in the case of alkaline reagents the amount is normalised to a lime-weight equivalent by stoichiometry.

All emission data are corrected for standard pressure and temperature conditions and normalised for a reference oxygen level of 11 %, but otherwise are presented as measured, without adding or subtracting the measurement uncertainty or taking into account the specific rules applied for compliance.

Simplified graphs included in Chapter 3

Due to the large number of reference lines included and the large space needed for their visualisation, the graphs showing emission levels plant by plant are presented in Annex 8.6, Annex 8.7 and Annex 8.8. The graphs shown within Chapter 3 intend to represent the same information in a condensed form, by showing the distribution of emission levels achieved by the set of plants. For each of the graphs shown in Chapter 3 there is a corresponding detailed graph in Annex 8.6 or Annex 8.8; this correspondence is clearly indicated throughout Chapter 3.

Chapter 3's simplified graphs are built as follows:

The horizontal axis shows a series of concentration ranges, for instance, in Figure 3.1, from 0 mg/Nm³ to 2 mg/Nm³, from 2 mg/Nm³ to 4 mg/Nm³, and so on up to the last range that indicates concentrations exceeding 20 mg/Nm³.

The vertical axis indicates the percentage of the reference lines within the scope of each graph (for instance, in Figure 3.1, of all reference lines predominantly incinerating municipal solid waste) that achieve an emission level within the range shown on the horizontal axis.

This percentage changes depending on the averaging period and on the data filter represented. In Figure 3.1, for example, in correspondence of each concentration range three bars are shown, representing the continuously monitored HCl emission levels achieved in terms of yearly average, 'fine' daily average (the yearly maximum of daily averages derived on the basis of the 'fine' data filter), and 'base' daily average (the yearly maximum of daily averages derived on the basis of the 'base' data filter). In the example of Figure 3.1, for instance, an HCl emission level between 0 mg/Nm³ and 2 mg/Nm³ is achieved as a yearly average by 34 % of the reference lines, and as a maximum of the daily averages by 18 % of the reference lines when derived on the basis of the 'fine' data filter and by 14 % of the reference lines when derived on the basis of the 'base' data filter. Likewise, an HCl emission level between 6 mg/Nm³ and 8 mg/Nm³ is achieved as a yearly average by 17 % of the reference lines, and as a maximum of the daily averages by 12 % of the reference lines when derived on the basis of the 'fine' data filter and by 8 % of the reference lines when derived on the basis of the 'base' data filter.

For the case of periodically monitored emissions, the stack charts show two bars in correspondence of each emission concentration range, representing the percentage of reference lines within that concentration range based either on the maximum of the reported emission measurements or on the average of the reported emission measurements.

Underneath the stack chart described above, a series of pie charts gives an indication of the main techniques or other plant characteristics that may be associated with the reference lines

that achieve certain emission levels. In the example of Figure 3.1, the pie charts show the share of reference lines, among those achieving emission levels within the concentration range shown on the horizontal axis of the stack chart, that reported the use of a wet scrubber. For instance, 93 % of the reference lines achieving HCl emission levels between 0 mg/Nm³ and 2 mg/Nm³ are fitted with a wet scrubber (7 % of them only with dry or semi-wet techniques). This share goes down to 35 % for the reference lines achieving HCl emission levels between 6 mg/Nm³ and 8 mg/Nm³ (65 % of those reference lines being fitted only with dry or semi-wet techniques). These shares are generally based on the 'base' data filter for continuously monitored emissions, and on the maximum reported values for periodically monitored emissions.

For certain pollutants, the pie charts show more than two techniques. Three classes of techniques are shown for instance for NO_x (reference lines fitted with: SCR with or without SNCR; SNCR but not SCR; primary techniques only) or for NH₃ (reference lines fitted with: SCR; SNCR and a downstream wet scrubber; SNCR without a wet scrubber). In other cases where no specific secondary techniques are relevant, the pie charts instead indicate the size of the reference lines; this is the case for CO emissions for instance.

The following subsections show this information for plants combusting different types of waste, separately for: municipal solid waste (MSW); other non-hazardous waste (ONHW); hazardous waste (HW); sewage sludge (SS); and clinical waste (CW). Since in reality different types of waste may be processed in the same plant, the allocation of plants to one waste type or another is based on the predominant type of waste, in terms of mass, incinerated by each plant in the reference year 2014.

3.2.2.1 Emissions to air from the incineration of municipal solid waste and other non-hazardous waste

Hydrogen chloride and hydrogen fluoride

Three main types of flue-gas cleaning systems are in use for HCl and HF:

1. Wet systems using different types of scrubbers in which HCl is taken out by water, usually working at a pH < 1.
2. Semi-wet systems (or semi-dry systems) using milk of lime.
3. Dry systems, which use hydrated lime, or sodium bicarbonate (usually in combination with activated carbon), often combined with a bag filter.

[74, TWG 2004]

The emissions will depend, among other factors, on the amount of reagents used and the operational/design set point of the plant.

HCl emission data, based on continuous measurements, are shown in the following figures, in simplified form within this chapter and in detail in Annex 8.6; half-hourly emission levels are shown in Annex 8.7:

- Figure 3.1, for 202 reference lines incinerating predominantly MSW. Due to the large number of data points represented, the corresponding detailed graphs are divided into three figures for readability. These are Figure 8.2, Figure 8.3 and Figure 8.4 for daily and yearly emission levels, and Figure 8.52, Figure 8.53 and Figure 8.54 for half-hourly emission levels.
- Figure 3.2, for 54 reference lines incinerating predominantly ONHW. The corresponding detailed graphs are Figure 8.5 for daily and yearly emission levels, and Figure 8.55 for half-hourly emission levels.

For each emission concentration range represented on the horizontal axis, the pie charts underneath show the shares of reference lines, among those achieving emission levels within the given range, that are fitted with a wet scrubber and with other techniques (such as DSI or semi-wet absorbers).

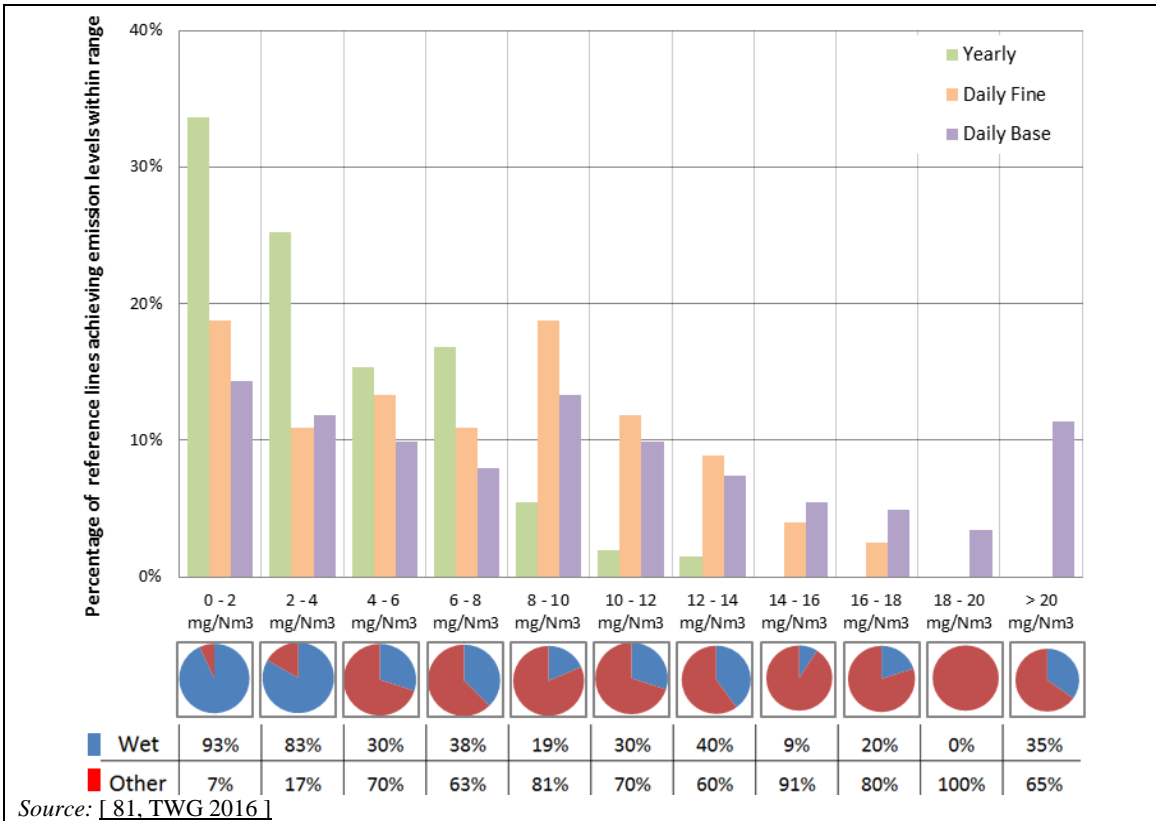

Figure 3.1: Continuously monitored HCl emissions to air from reference lines incinerating predominantly MSW

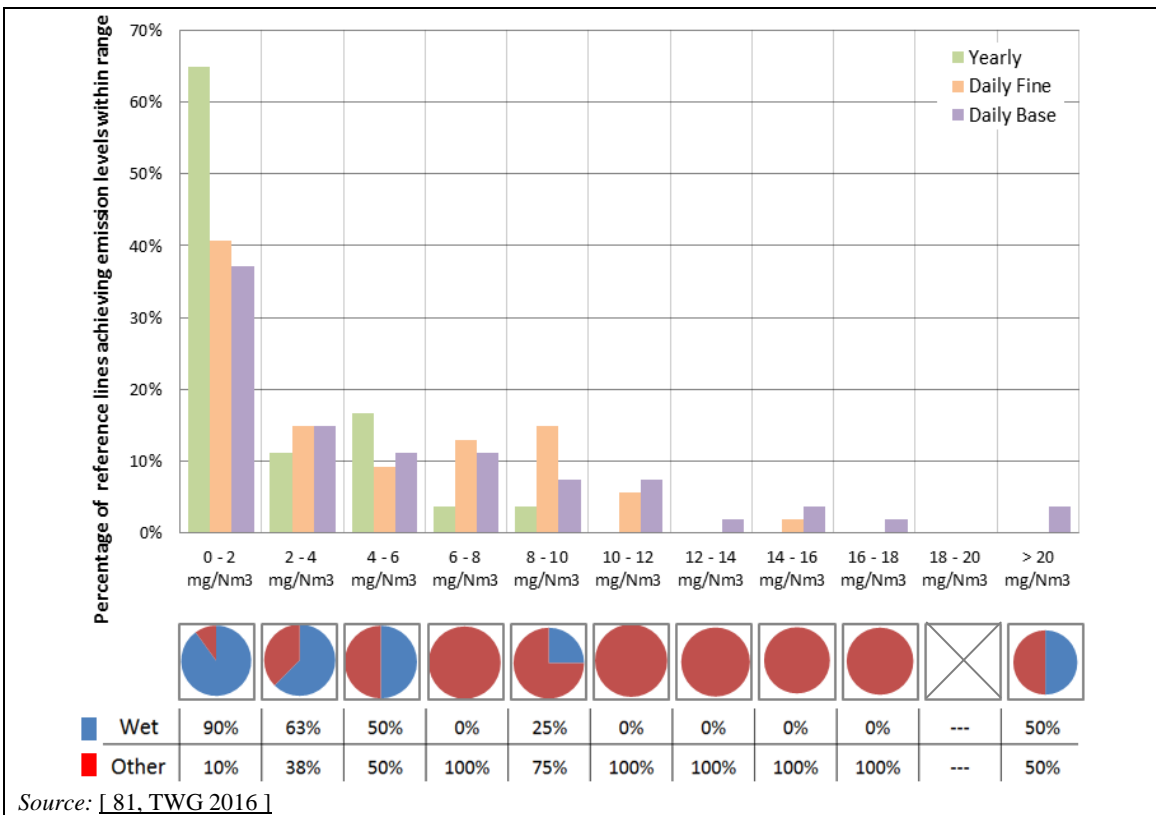

Figure 3.2: Continuously monitored HCl emissions to air from reference lines incinerating predominantly ONHW

The emission levels range between close to the limit of quantification and 13 mg/Nm^3 as a yearly average and 17 mg/Nm^3 as a maximum daily average. In some cases higher emission peaks may be recorded, generally related to OTNOC.

The graphs show that plants fitted with a wet scrubber generally achieve lower emission levels (mostly below 2 mg/Nm^3 as a yearly average and 4 mg/Nm^3 as a maximum daily average) than plants fitted with dry sorbent injection or with semi-wet techniques.

The reported data do not show a clear correlation between the achieved emission levels and the type and amount of reagent used, the age and size of the plant, or the furnace type.

The data on hydrogen fluoride (HF) are mainly based on periodic measurements. HF is reduced by the same techniques as HCl, meaning that an effective flue-gas cleaning system for HCl will also deal with HF. Since the chemical behaviour of HF is not exactly the same as that of HCl, the efficiency of HF removal will differ slightly from system to system.

HF emission data are shown in the following figures, in simplified form within this chapter and in detail in Annex 8.6 and Annex 8.8; half-hourly emission levels are shown Annex 8.7:

- Figure 3.3, for 157 reference lines incinerating predominantly MSW and monitoring HF periodically. Due to the large number of data points represented, the corresponding detailed graphs are divided into two figures for readability. These are Figure 8.106 and Figure 8.107.
- Figure 3.4, for 81 reference lines incinerating predominantly MSW and monitoring HF continuously. The corresponding detailed graphs are Figure 8.6 for daily and yearly emission levels, and Figure 8.56 for half-hourly emission levels.
- Figure 3.5, for 31 reference lines incinerating predominantly ONHW and monitoring HF periodically. The corresponding detailed graph is Figure 8.108.
- Figure 3.6, for 20 reference lines incinerating predominantly ONHW and monitoring HF continuously. The corresponding detailed graphs are Figure 8.7 for daily and yearly emission levels, and Figure 8.57 for half-hourly emission levels.

For each emission concentration range represented on the horizontal axis, the pie charts underneath show the shares of reference lines, among those achieving emission levels within the given range, that are fitted with a wet scrubber and with other techniques (such as DSI or semi-wet absorbers).

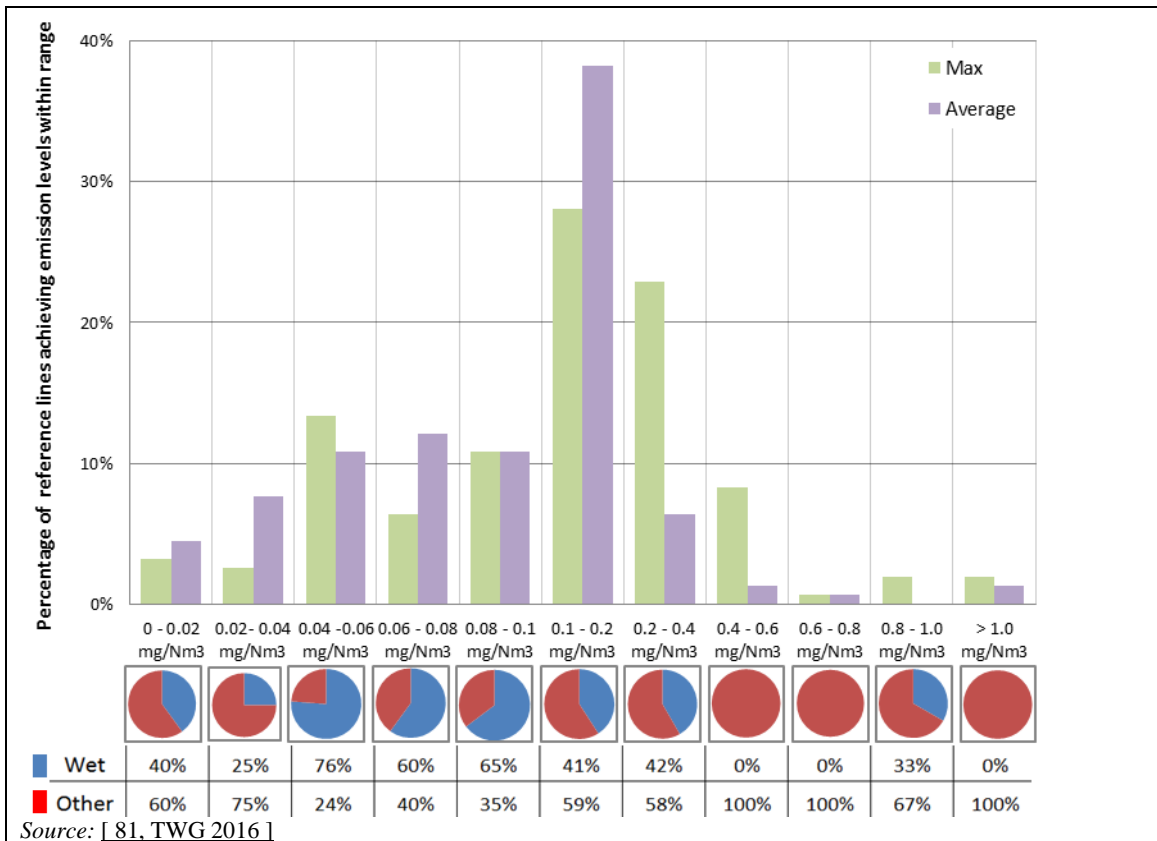

Figure 3.3: Periodically monitored HF emissions to air from reference lines incinerating predominantly MSW

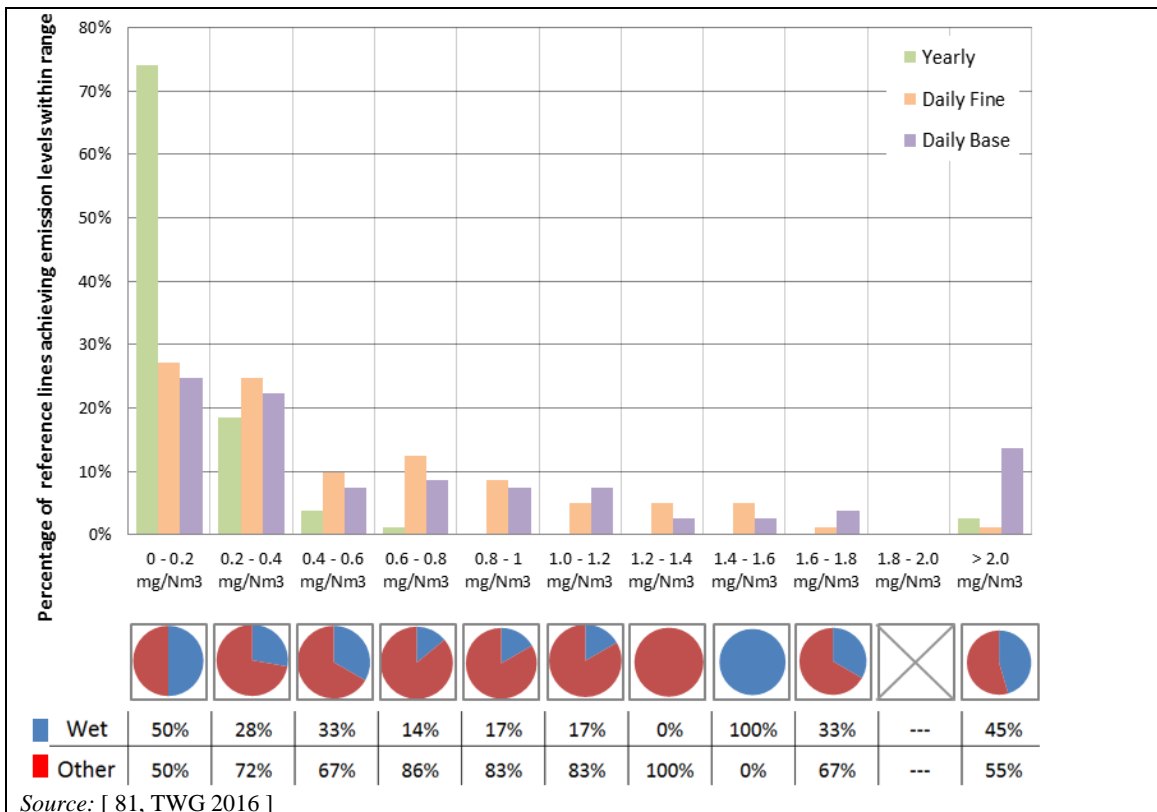

Figure 3.4: Continuously monitored HF emissions to air from reference lines incinerating predominantly MSW

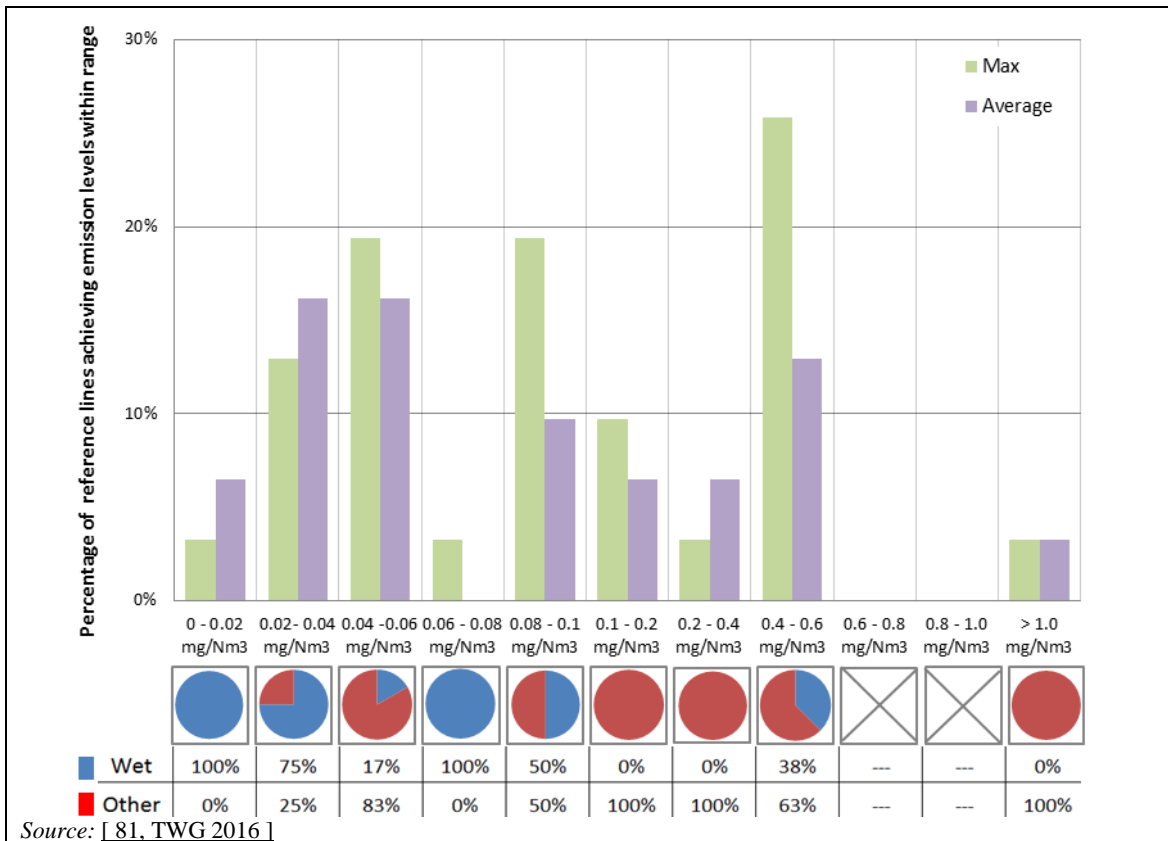

Figure 3.5: Periodically monitored HF emissions to air from reference lines incinerating predominantly ONHW

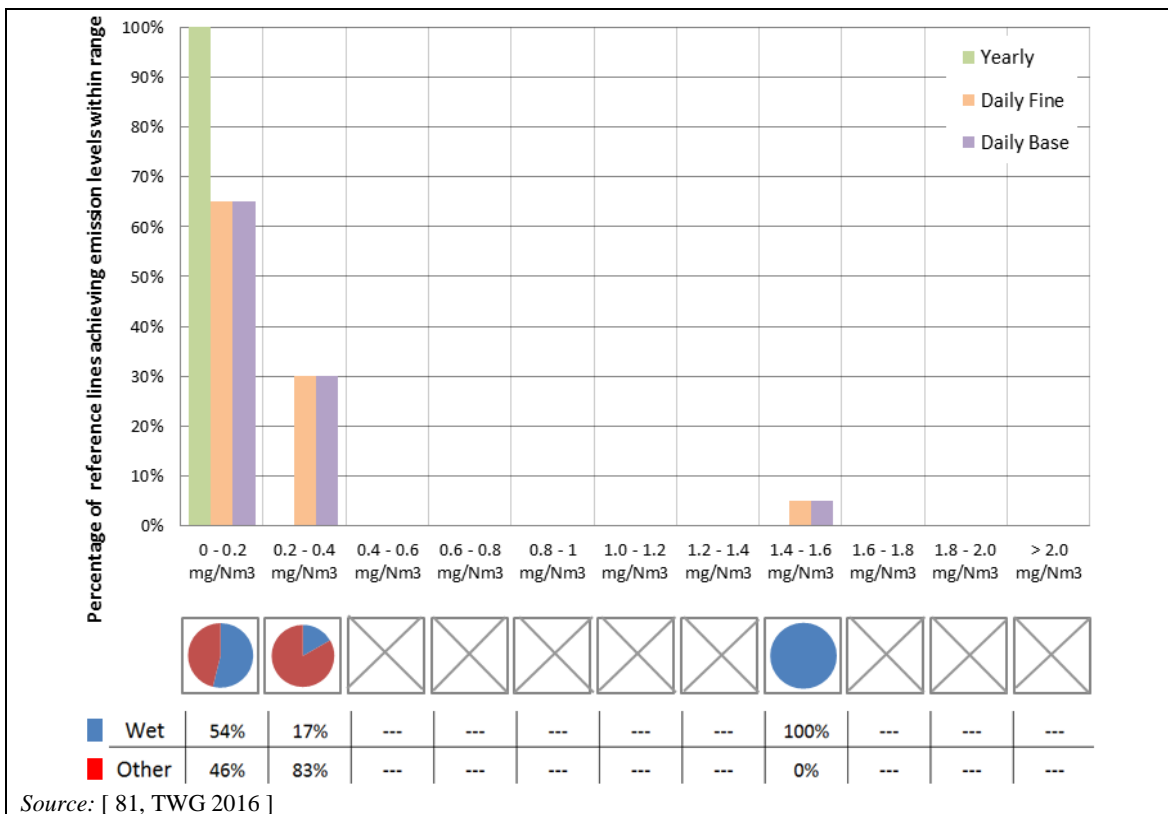

Figure 3.6: Continuously monitored HF emissions to air from reference lines incinerating predominantly ONHW

The emission levels range between close to the limit of quantification and 0.4 mg/Nm^3 as a yearly average and 1.6 mg/Nm^3 as a maximum daily average, with the exception of one plant reaching 0.7 mg/Nm^3 as a yearly average and one exceeding 3 mg/Nm^3 as a maximum daily average. Periodically monitored emissions are between close to the limit of quantification and 0.6 mg/Nm^3 , with the exception of six plants that report emissions between 1 mg/Nm^3 and 4 mg/Nm^3 .

The reported data do not show a clear correlation between the achieved emission levels and the technique installed, the type and amount of reagent used, the age and size of the plant, or the furnace type.

The types of flue-gas cleaning systems in use are the same as those for HCl, with the main difference that wet scrubbers are operated at a slightly basic pH (usually 7–8).

SO₂ emission data, based on continuous measurements, are shown in the following figures, in simplified form within this chapter and in detail in Annex 8.6; half-hourly emission levels are shown Annex 8.7:

- Figure 3.7, for 204 reference lines incinerating predominantly MSW. Due to the large number of data points represented, the corresponding detailed graphs are divided into three figures for readability. These are Figure 8.8, Figure 8.9 and Figure 8.10 for daily and yearly emission levels, and Figure 8.58, Figure 8.59 and Figure 8.60 for half-hourly emission levels.
- Figure 3.8, for 54 reference lines incinerating predominantly ONHW. The corresponding detailed graphs are Figure 8.11 for daily and yearly emission levels, and Figure 8.61 for half-hourly emission levels.

For each emission concentration range represented on the horizontal axis, the pie charts underneath show the shares of reference lines, among those achieving emission levels within the given range, that are fitted with a wet scrubber and with other techniques (such as DSI or semi-wet absorbers).

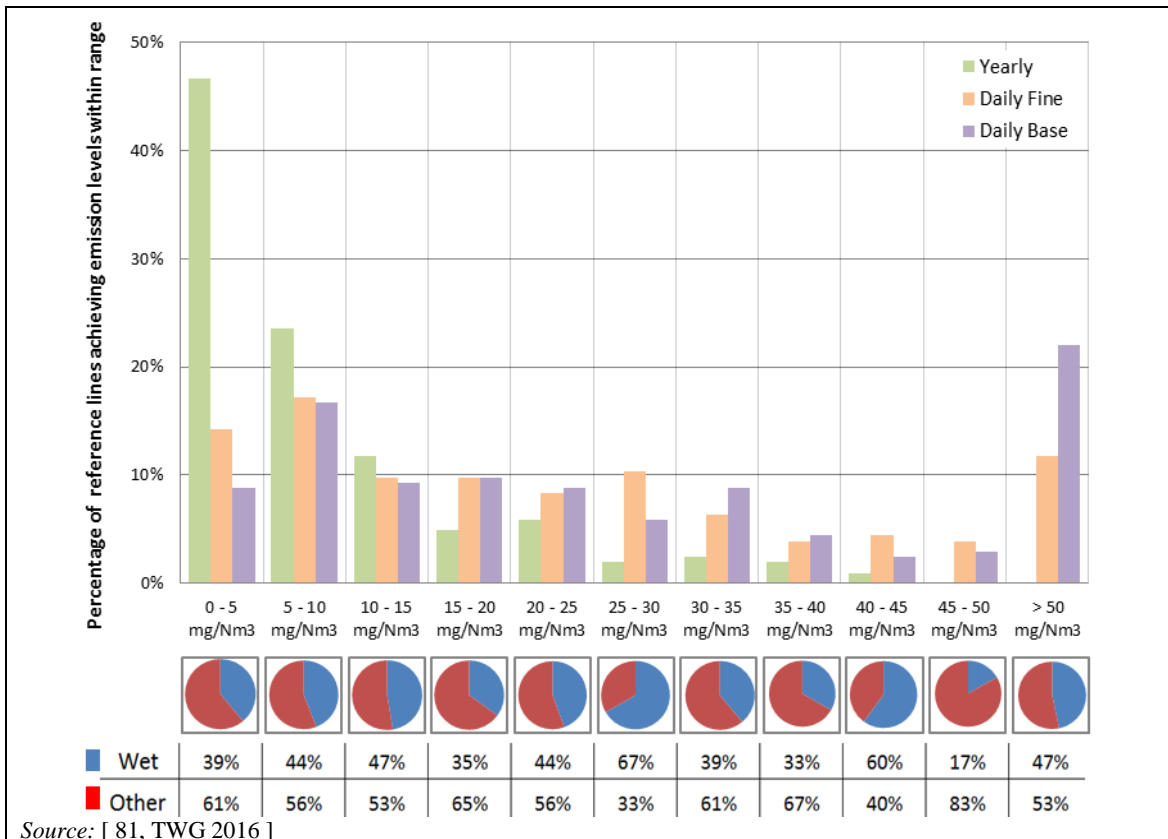

Figure 3.7: Continuously monitored SO₂ emissions to air from reference lines incinerating predominantly MSW

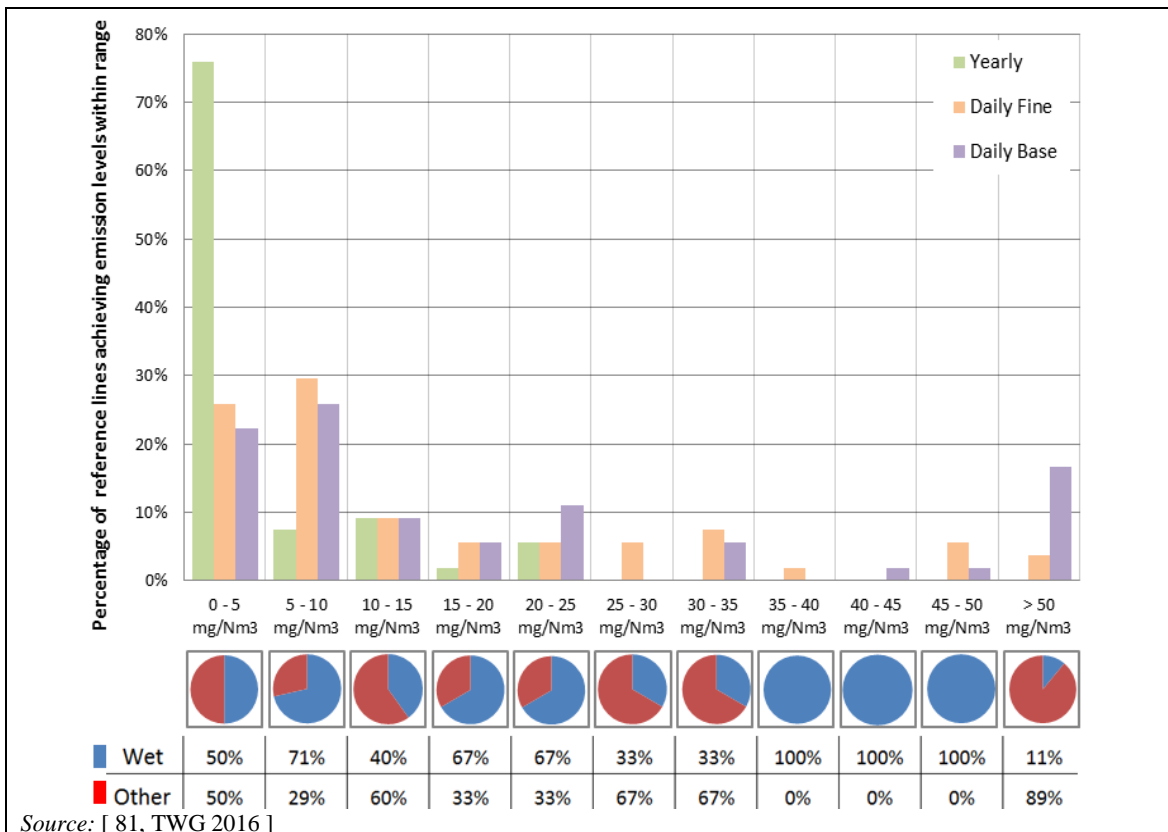

Figure 3.8: Continuously monitored SO₂ emissions to air from reference lines incinerating predominantly ONHW

The emission levels range between close to the limit of quantification and 45 mg/Nm^3 as a yearly average and 90 mg/Nm^3 as a maximum daily average.

The reported data do not show a clear correlation between the achieved emission levels and the technique installed, the type and amount of reagent used, the age and size of the plant, or the furnace type.

Dust

For dust, three main types of flue-gas cleaning systems are in use:

1. Dry electrostatic precipitator (dry ESP).
2. Wet electrostatic precipitator (wet ESP) (note: the wet ESP is not often used in MSWI).
3. Bag filter (BF).

In several cases, two of these techniques have been combined, for example a dry electrostatic precipitator for pre-dedusting after the boiler with a bag filter before the stack. This allows the separation of fly ash from FGC residues and separate recycling/disposal.

Wet scrubbers and fixed adsorption beds can also contribute to dust removal.

Some plants also use cyclones or multi-cyclones for pre-dedusting. Although this is not a common configuration, there are example plants where the flue-gas cleaning system does not include a bag filter or ESP but combines wet scrubbing with a (multi-)cyclone.

Interdependencies between different parts of the system are frequently seen in the overall flue-gas cleaning system design. For instance, in the case of dry and semi-wet systems, bag filters also act as a reactor for acid gas removal. In addition, they can enable the removal of PCDD/F and metals (including mercury and cadmium) if a suitable reagent is used (e.g. activated carbon).

Dust emission data, based on continuous measurements, are shown in the following figures, in simplified form within this chapter and in detail in Annex 8.6; half-hourly emission levels are shown Annex 8.7:

- Figure 3.9, for 203 reference lines incinerating predominantly MSW. Due to the large number of data points represented, the corresponding detailed graphs are divided into three figures for readability. These are Figure 8.12, Figure 8.13 and Figure 8.14 for daily and yearly emission levels, and Figure 8.62, Figure 8.63 and Figure 8.64 for half-hourly emission levels.
- Figure 3.10, for 54 reference lines incinerating predominantly ONHW. The corresponding detailed graphs are Figure 8.15 for daily and yearly emission levels, and Figure 8.65 for half-hourly emission levels.

For each emission concentration range represented on the horizontal axis, the pie charts underneath show the shares of reference lines, among those achieving emission levels within the given range, that are fitted with a bag filter and with other techniques (such as ESPs).

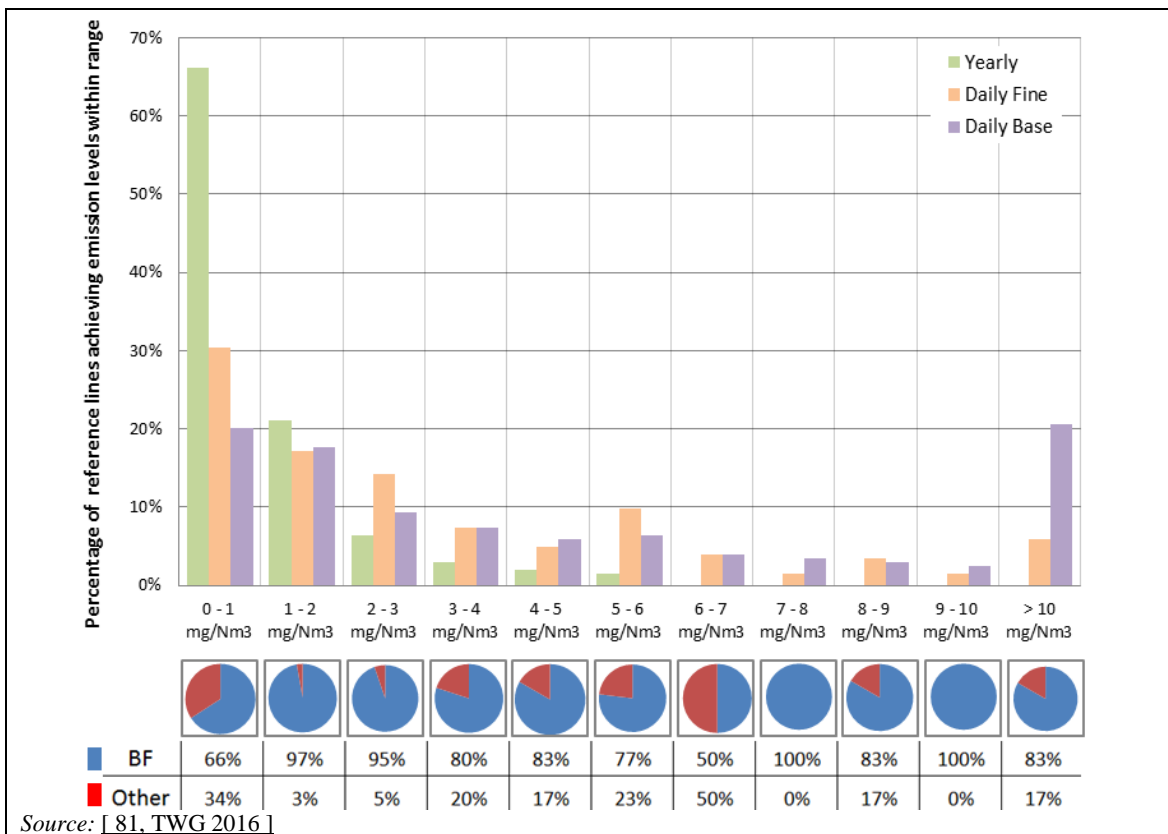

Figure 3.9: Continuously monitored dust emissions to air from reference lines incinerating predominantly MSW

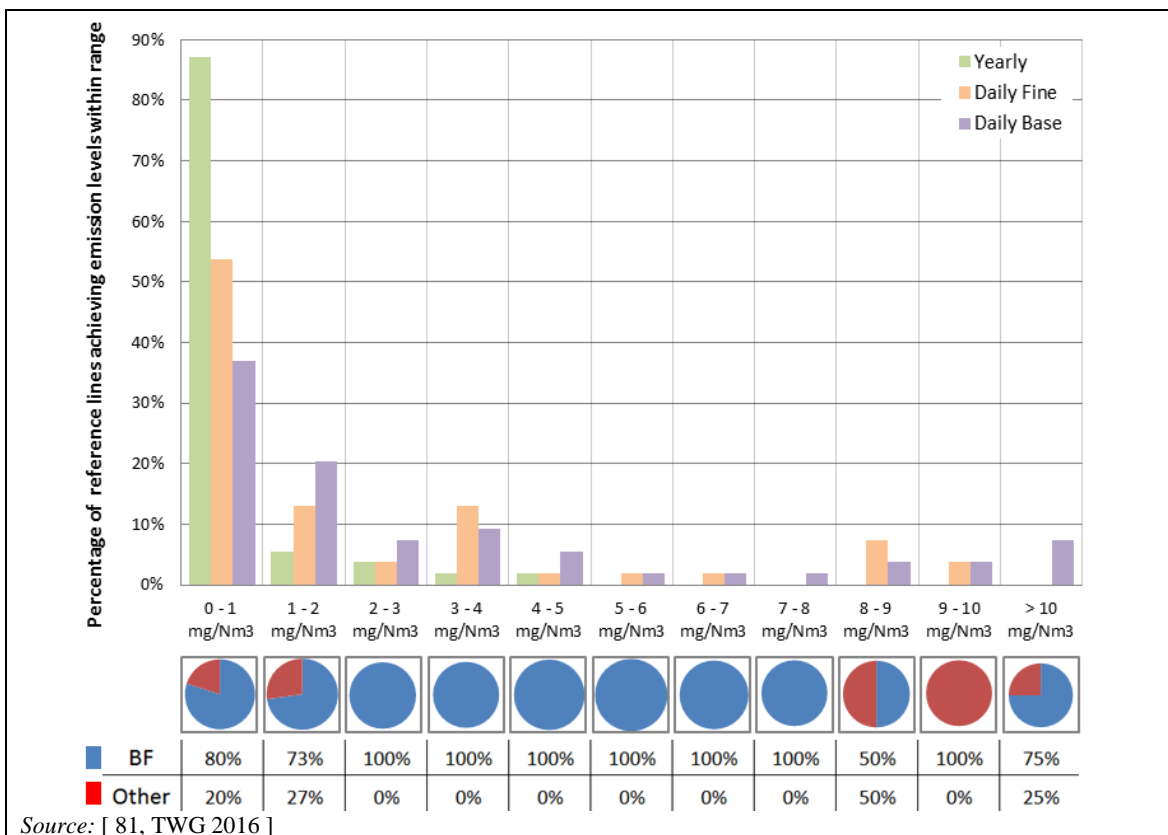

Figure 3.10: Continuously monitored dust emissions to air from reference lines incinerating predominantly ONHW

The emission levels range between close to the limit of quantification and 6 mg/Nm^3 as a yearly average and 17 mg/Nm^3 as a maximum daily average. In some cases higher emission peaks may be recorded, generally related to OTNOC.

The graphs show that the plants fitted with a bag filter generally achieve emission levels below 2.5 mg/Nm^3 as a yearly average; only a few plants report yearly average levels between 3 mg/Nm^3 and 6 mg/Nm^3 , and, with the exception of UK7-1 and UK7-2, they are plants fitted with an ESP. As a maximum daily average, the vast majority of plants achieve levels below 7 mg/Nm^3 , and below 5 mg/Nm^3 for plants fitted with a well-maintained bag filter except in cases where the daily average emission level is substantially affected by occurrences such as filter bag failures or a start-up where the bag filter is being bypassed.

The reported data do not show a clear correlation between the achieved emission levels and the type and amount of reagent used, the age and size of the plant, or the furnace type.

Nitrogen oxides

A variety of combustion control techniques are used to reduce NO_x formation. SCR and SNCR are the main secondary techniques in use for the further abatement of NO_x emissions in MSWIs.

NO_x emission data, based on continuous measurements, are shown in the following figures, in simplified form within this chapter and in detail in Annex 8.6; half-hourly emission levels are shown Annex 8.7:

- Figure 3.11, for 204 reference lines incinerating predominantly MSW. Due to the large number of data points represented, the corresponding detailed graphs are divided into three figures for readability. These are Figure 8.16, Figure 8.17 and Figure 8.18 for daily and yearly emission levels, and Figure 8.66, Figure 8.67 and Figure 8.68 for half-hourly emission levels.
- Figure 3.12, for 53 reference lines incinerating predominantly ONHW. The corresponding detailed graphs are Figure 8.19 for daily and yearly emission levels, and Figure 8.69 for half-hourly emission levels.

For each emission concentration range represented on the horizontal axis, the pie charts underneath show the shares of reference lines, among those achieving emission levels within the given range, that are fitted with SCR, with SNCR but no SCR, and with primary techniques at most.

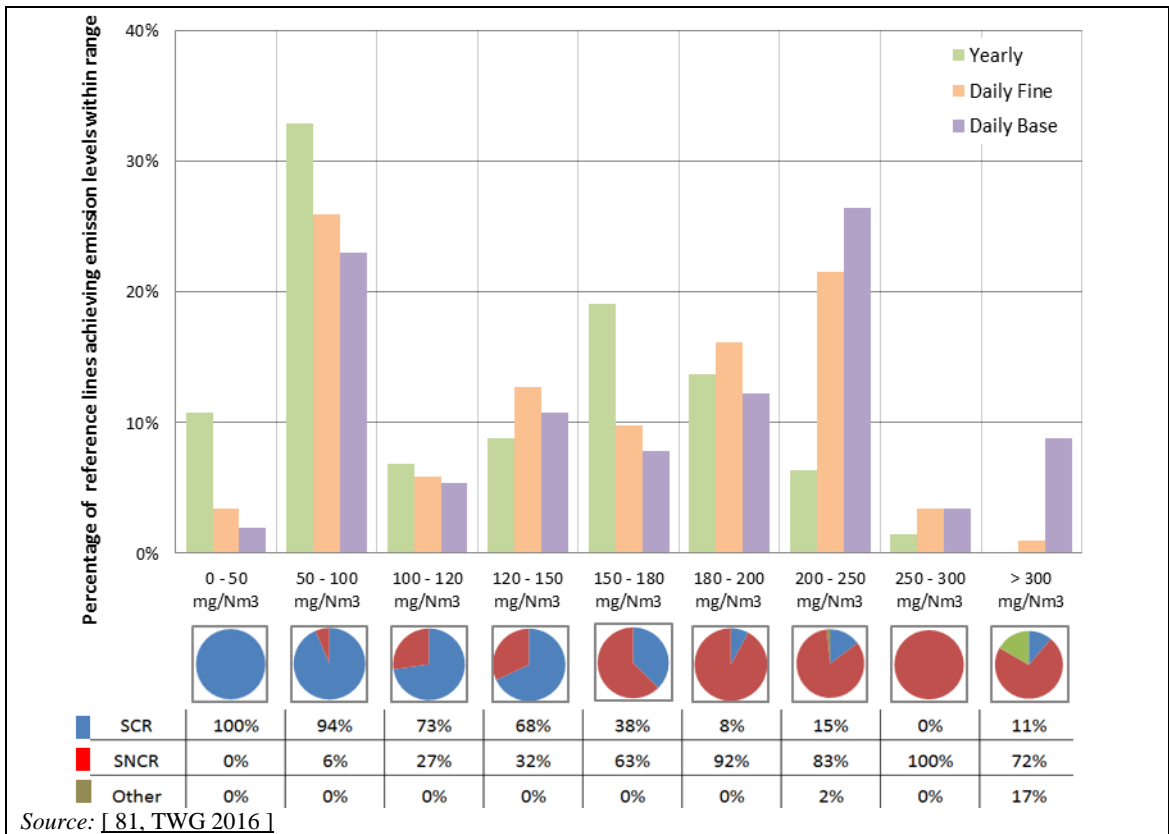

Figure 3.11: Continuously monitored NO_x emissions to air from reference lines incinerating predominantly MSW

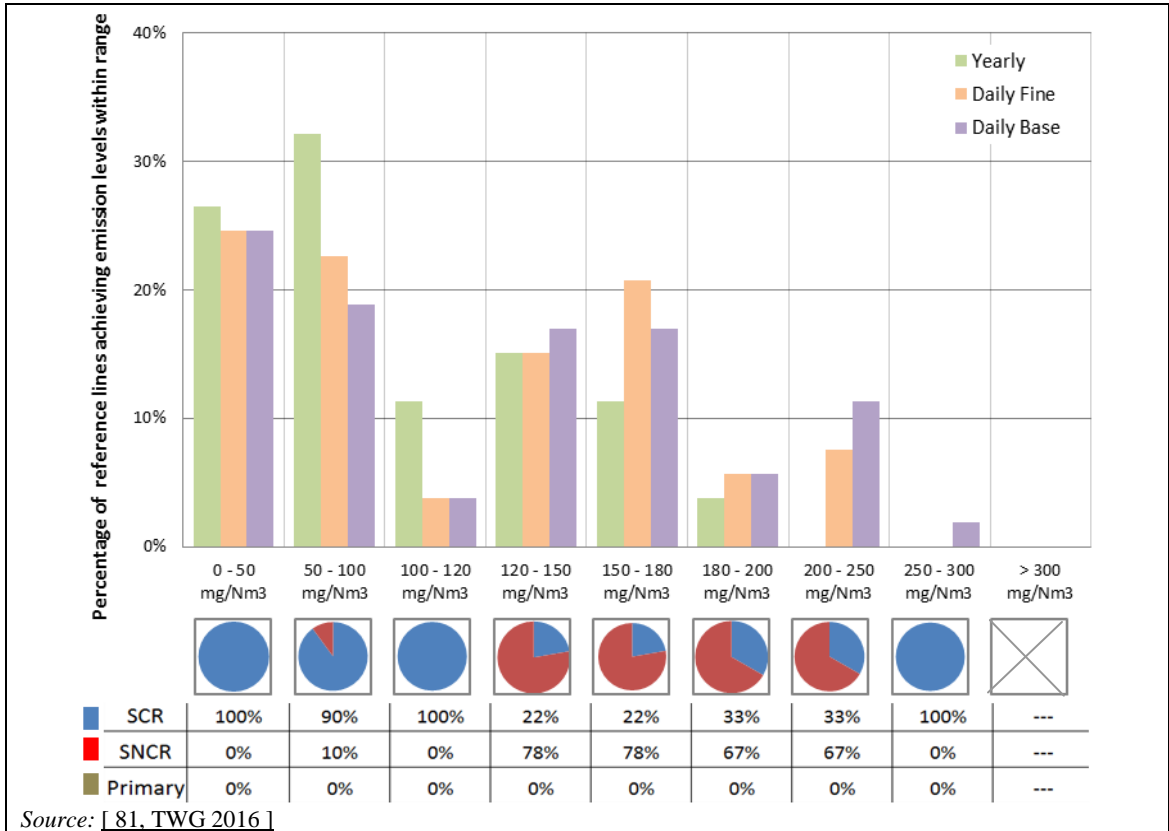

Figure 3.12: Continuously monitored NO_x emissions to air from reference lines incinerating predominantly ONHW

The emission levels range between 18 mg/Nm³ and 275 mg/Nm³ as a yearly average and between 22 mg/Nm³ and 350 mg/Nm³ as a maximum daily average. In some cases higher emission peaks may be recorded in OTNOC, but for the majority of cases little difference is observed between the 'base' and 'fine' data filtering for daily averages, and – especially for plants fitted with SCR – the maximum daily average is in most cases within 125 % of the yearly average.

The graphs show that plants fitted with SCR generally achieve substantially lower emission levels (down to a minimum of 20 mg/Nm³ and generally below 100 mg/Nm³ as a yearly average and 130 mg/Nm³ as a maximum daily average) than plants fitted with SNCR. The best performing plants fitted with SNCR achieve levels down to 54 mg/Nm³ as a yearly average and 76 mg/Nm³ as a maximum daily average.

The reported data do not show a clear correlation between the achieved emission levels and the type and amount of reagent used, the age and size of the plant, or the furnace type.

Ammonia

Ammonia emissions are related to reactant slip from SCR or SNCR. The main technique in use to control such emissions is process optimisation as well as good maintenance of the catalyst in the case of SCR. For SNCR, an efficient removal of ammonia slip can be achieved by a wet scrubber operated at low pH. SCR can also be implemented as slip catalyst to further react the unreacted ammonia after the main reduction has taken place in a SNCR system.

Ammonia emission data, based on either continuous or periodic measurements, are shown in the following figures, in simplified form within this chapter and in detail in Annex 8.6 and Annex 8.8; half-hourly emission levels are shown Annex 8.7:

- Figure 3.13, for 120 reference lines incinerating predominantly MSW and monitoring NH₃ periodically. Due to the large number of data points represented, the corresponding detailed graphs are divided into two figures for readability. These are Figure 8.109 and Figure 8.110.
- Figure 3.14, for 146 reference lines incinerating predominantly MSW and monitoring NH₃ continuously. Due to the large number of data points represented, the corresponding detailed graphs are divided into three figures for readability. These are Figure 8.20, Figure 8.21 and Figure 8.22 for daily and yearly emission levels, and Figure 8.70, Figure 8.71 and Figure 8.72 for half-hourly emission levels.
- Figure 3.15, for 27 reference lines incinerating predominantly ONHW and monitoring NH₃ periodically. The corresponding detailed graph is Figure 8.111.
- Figure 3.16, for 38 reference lines incinerating predominantly ONHW and monitoring NH₃ continuously. The corresponding detailed graphs are Figure 8.23 for daily and yearly emission levels, and Figure 8.73 for half-hourly emission levels.

For each emission concentration range represented on the horizontal axis, the pie charts underneath show the shares of reference lines, among those achieving emission levels within the given range, that are fitted with SCR, with SNCR and a downstream wet scrubber, and with SNCR and downstream dry techniques (emissions from plants not operating secondary de-NO_x techniques are not relevant for ammonia slip).

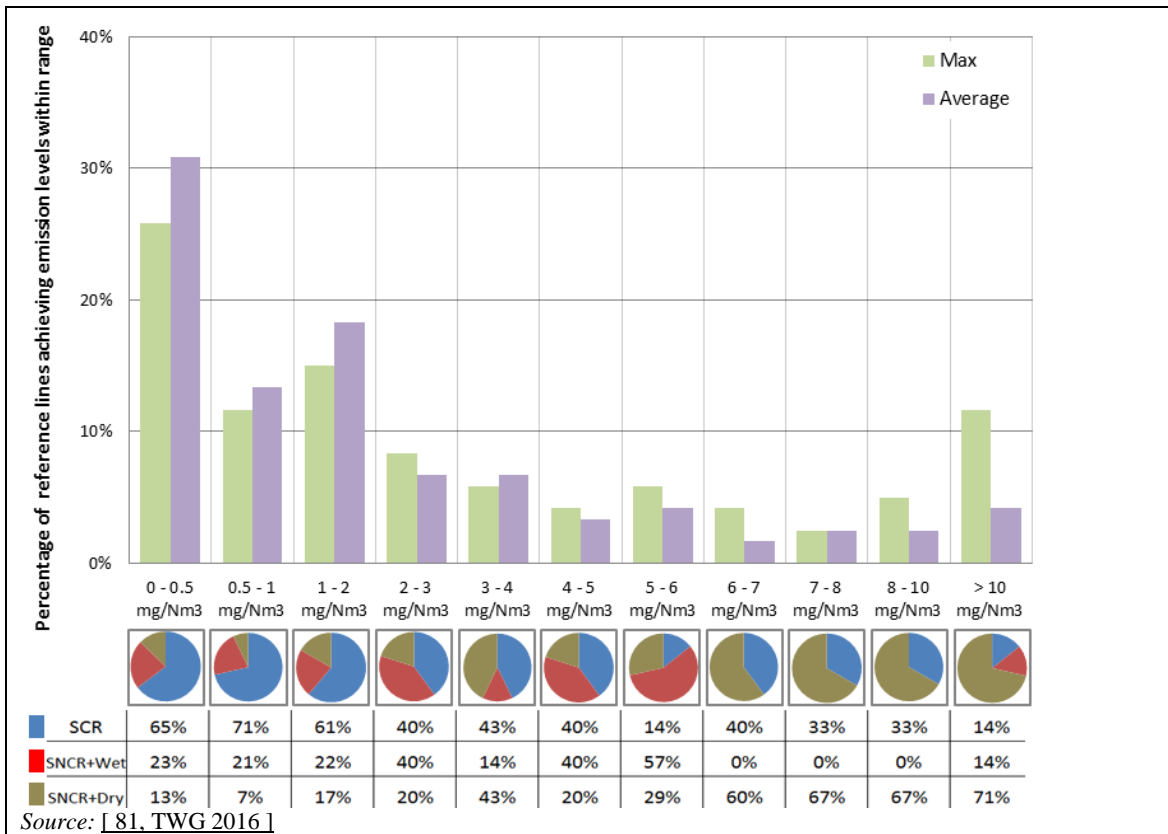

Figure 3.13: Periodically monitored NH₃ emissions to air from reference lines incinerating predominantly MSW

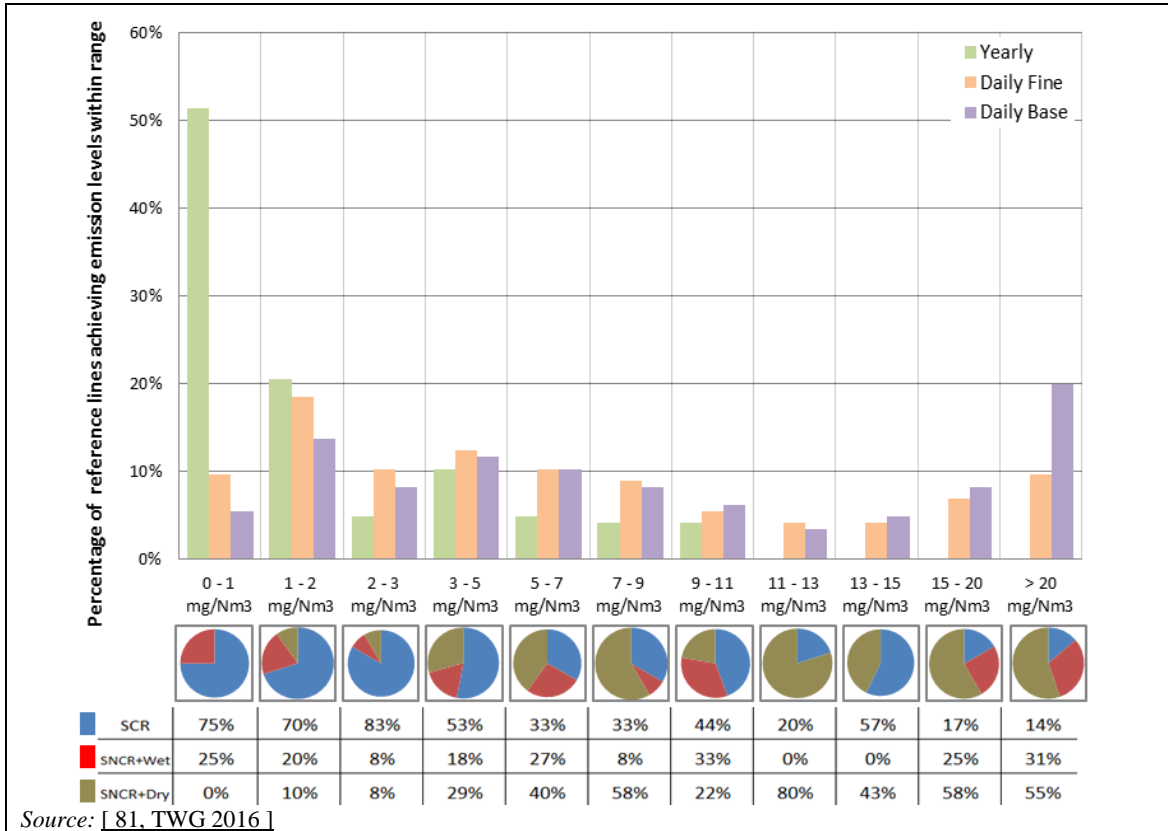

Figure 3.14: Continuously monitored NH₃ emissions to air from reference lines incinerating predominantly MSW

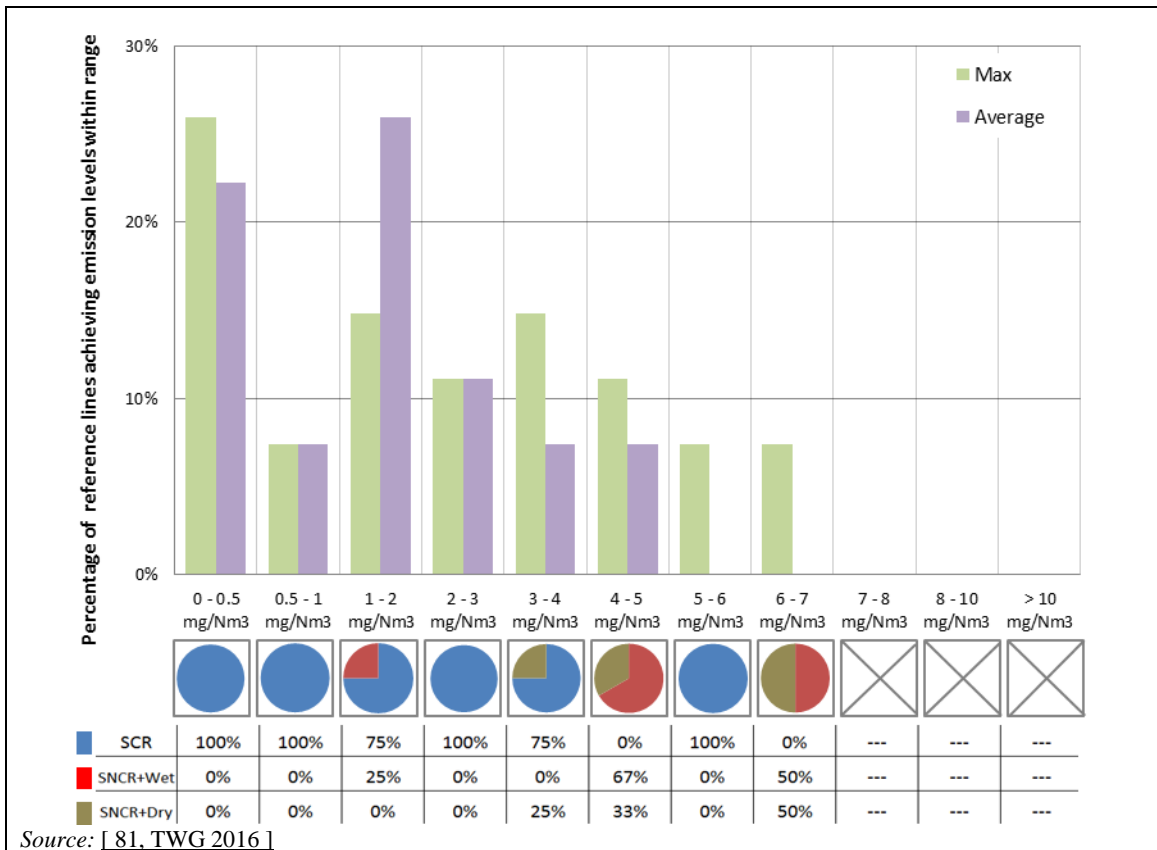

Figure 3.15: Periodically monitored NH₃ emissions to air from reference lines incinerating predominantly ONHW

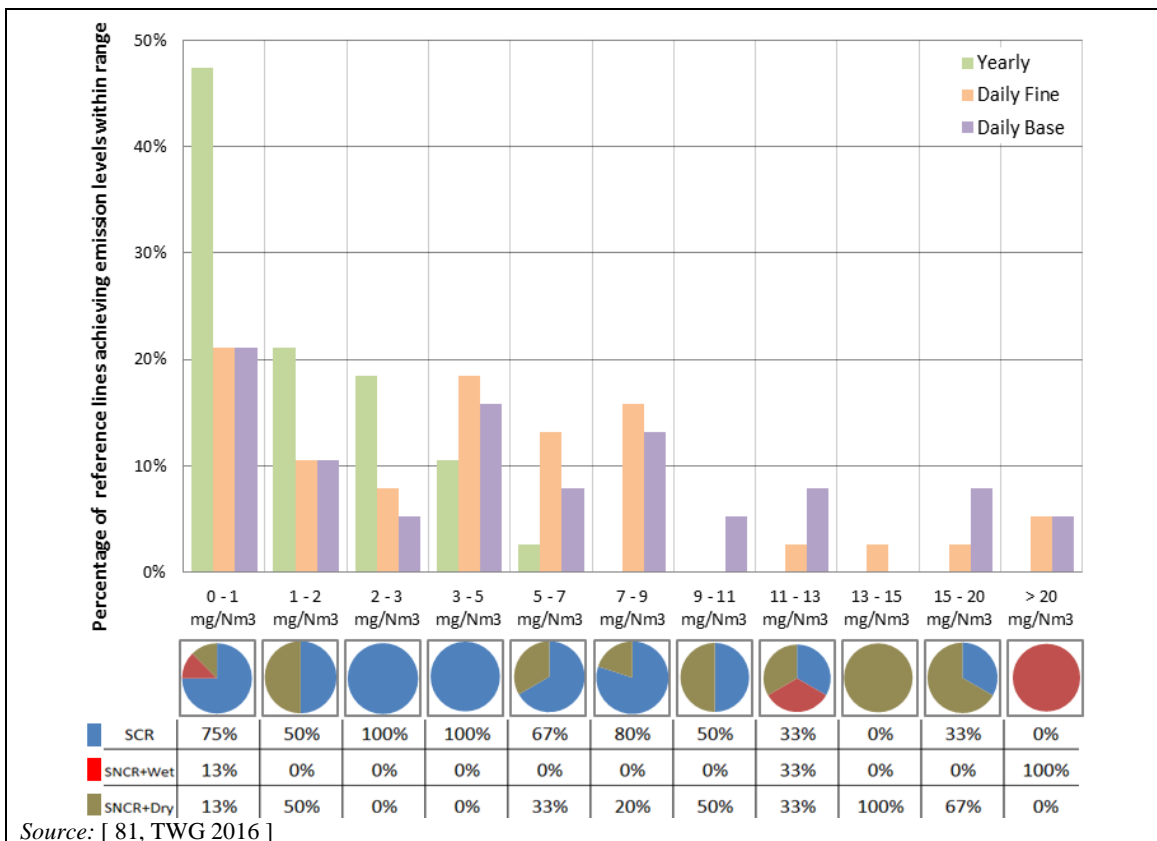

Figure 3.16: Continuously monitored NH₃ emissions to air from reference lines incinerating predominantly ONHW

The emission levels range between close to the limit of quantification and 10 mg/Nm^3 as a yearly average and 37 mg/Nm^3 as a maximum daily average or average over the sampling period. In some cases higher emission peaks are observed, generally related to OTNOC.

The graphs show that plants fitted with SCR generally achieve substantially lower ammonia emission levels (generally well below 5 mg/Nm^3 as a yearly average and 10 mg/Nm^3 as a maximum daily average or average over the sampling period) than plants fitted with SNCR. The best performing plants fitted with SNCR achieve very low levels down to the limit of quantification.

The reported data do not show a clear correlation between the achieved emission levels and the type and amount of reagent used, the age and size of the plant, or the furnace type.

TVOC

TVOC is an important measure of the efficiency of combustion. The achieved TVOC emission levels are mainly a result of the design of the firing system and the afterburning chamber, as the possibilities to decrease those emissions by flue-gas cleaning are limited. The same equipment used for the abatement of dust will also reduce solid organic particles. Some of the organic compounds will be reduced by the use of activated carbon.

TVOC emission data are based on continuous measurements and are shown in the following figures, in simplified form within this chapter and in detail in Annex 8.6; half-hourly emission levels are shown Annex 8.7:

- Figure 3.17, for 198 reference lines incinerating predominantly MSW. Due to the large number of data points represented, the corresponding detailed graphs are divided into three figures for readability. These are Figure 8.24, Figure 8.25 and Figure 8.26 for daily and yearly emission levels, and Figure 8.74, Figure 8.75 and Figure 8.76 for half-hourly emission levels.
- Figure 3.18, for 50 reference lines incinerating predominantly ONHW. The corresponding detailed graphs are Figure 8.27 for daily and yearly emission levels, and Figure 8.77 for half-hourly emission levels.

For each emission concentration range represented on the horizontal axis, the pie charts underneath show the shares of reference lines, among those achieving emission levels within the given range, that fall within the different size classes (the thresholds for small, medium and large plants are described in the introductory text of Chapter 3).

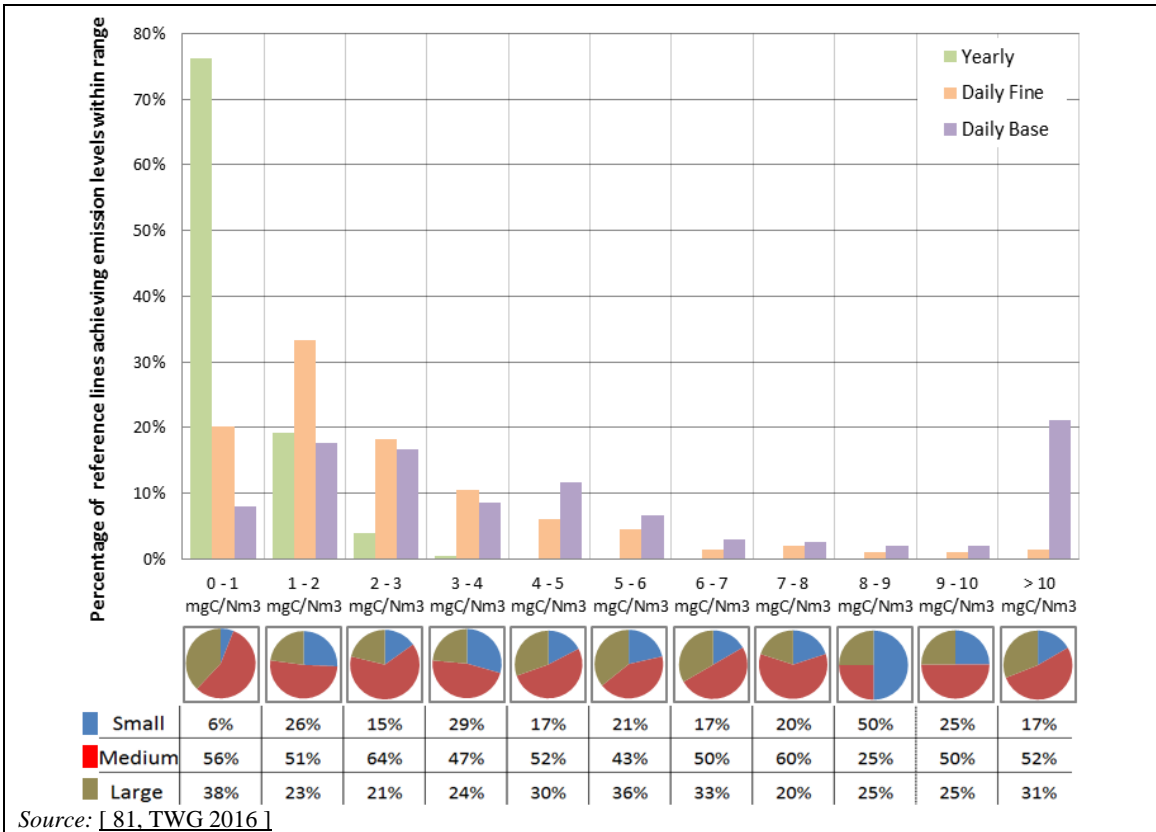

Figure 3.17: Continuously monitored TVOC emissions to air from reference lines incinerating predominantly MSW

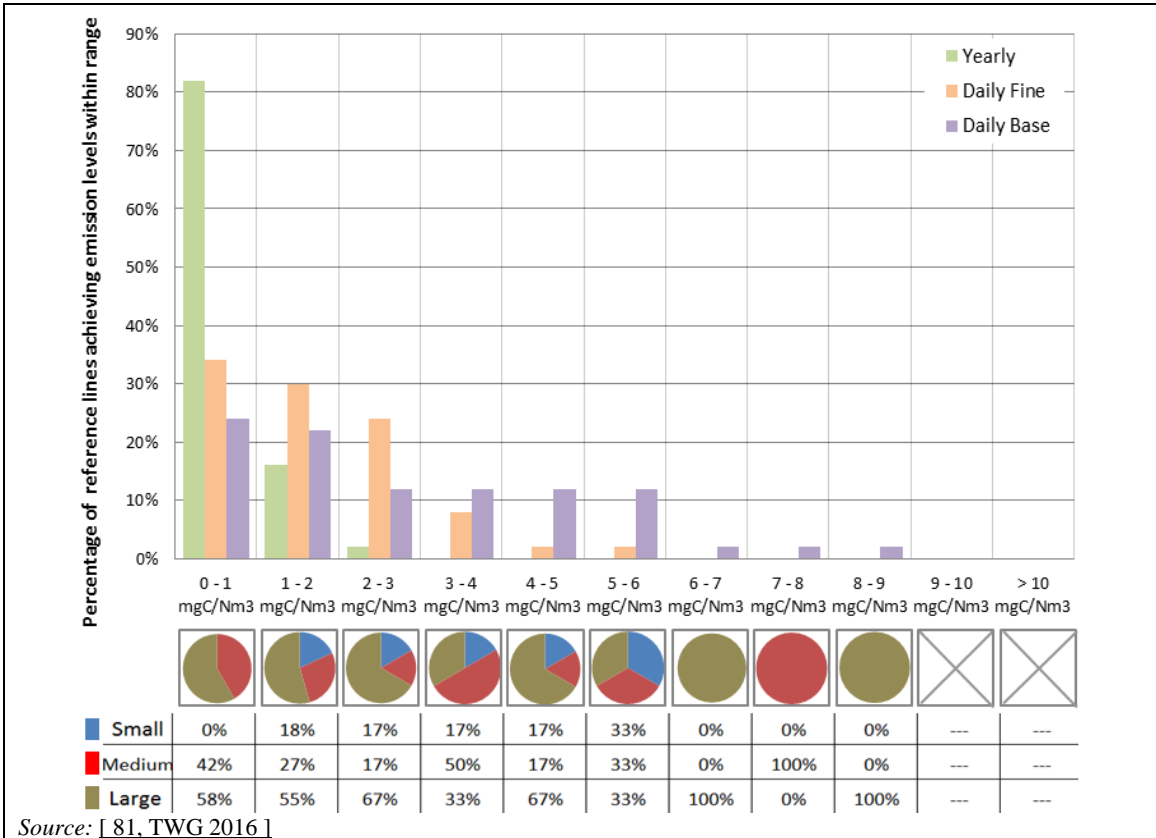

Figure 3.18: Continuously monitored TVOC emissions to air from reference lines incinerating predominantly ONHW

The emission levels range between close to the limit of quantification and 3 mg/Nm^3 as a yearly average and 17 mg/Nm^3 as a maximum daily average, although for the vast majority of plants the maximum daily average is below 6 mg/Nm^3 . While even the maximum daily levels are generally very low, the difference with respect to the yearly average tends to be substantial. This reflects the variability of TVOC emissions, which can show peaks when the combustion conditions in the furnace are not stable, e.g. at start-ups and shutdowns, and is also related to the occasionally large differences between the maxima of daily averages obtained with 'base' and 'fine' data filtering.

The reported data do not show a clear correlation between the achieved emission levels and the technique installed, the type and amount of reagent used, the age and size of the plant, or the furnace type.

Carbon monoxide

Like TVOC, CO also provides a measure of the quality of combustion. Low levels of CO emissions are associated with high-quality gas burnout.

CO emission data are based on continuous measurements and are shown in the following figures, in simplified form within this chapter and in detail in Annex 8.6; half-hourly emission levels are shown Annex 8.7:

- Figure 3.19, for 199 reference lines incinerating predominantly MSW. Due to the large number of data points represented, the corresponding detailed graphs are divided into three figures for readability. These are Figure 8.28, Figure 8.29 and Figure 8.30 for daily and yearly emission levels, and Figure 8.78, Figure 8.79 and Figure 8.80 for half-hourly emission levels.
- Figure 3.20, for 54 reference lines incinerating predominantly ONHW. The corresponding detailed graphs are Figure 8.31 for daily and yearly emission levels, and Figure 8.81 for half-hourly emission levels.

For each emission concentration range represented on the horizontal axis, the pie charts underneath show the shares of reference lines, among those achieving emission levels within the given range, that fall within the different size classes (the thresholds for small, medium and large plants are described in the introductory text of Chapter 3).

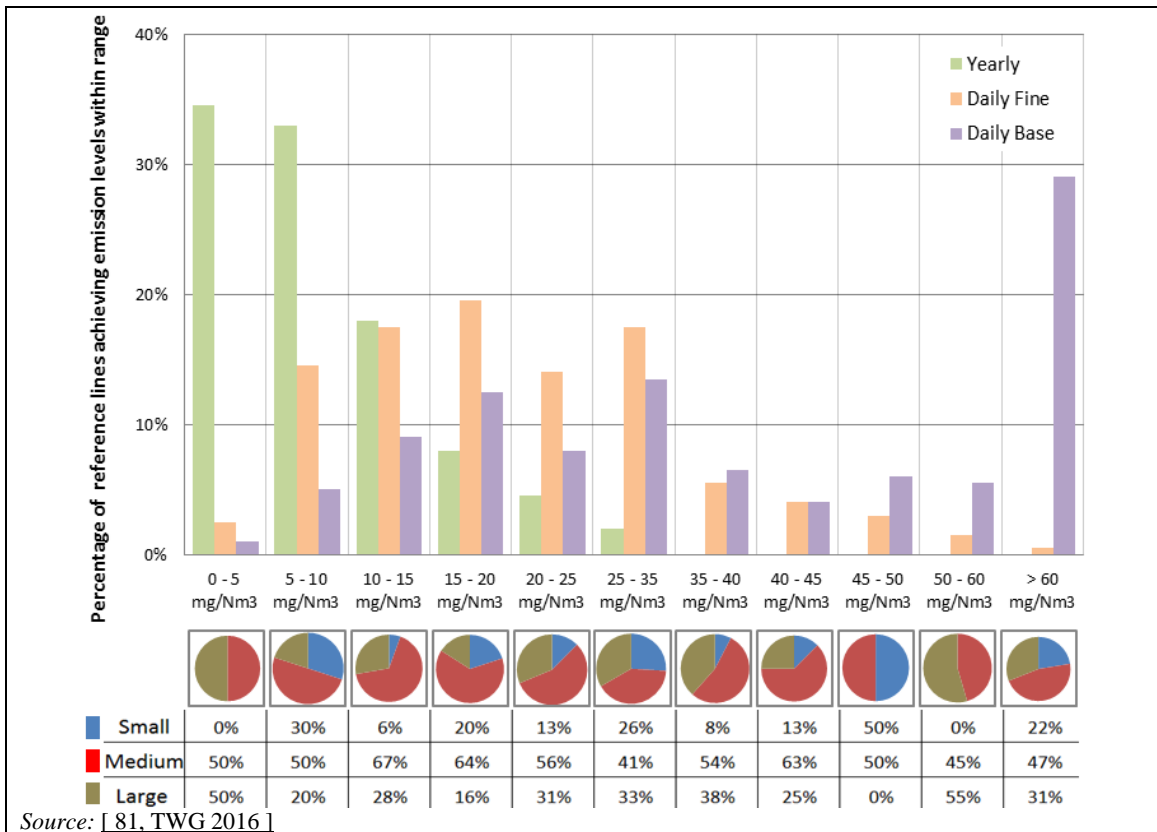

Figure 3.19: Continuously monitored CO emissions to air from reference lines incinerating predominantly MSW

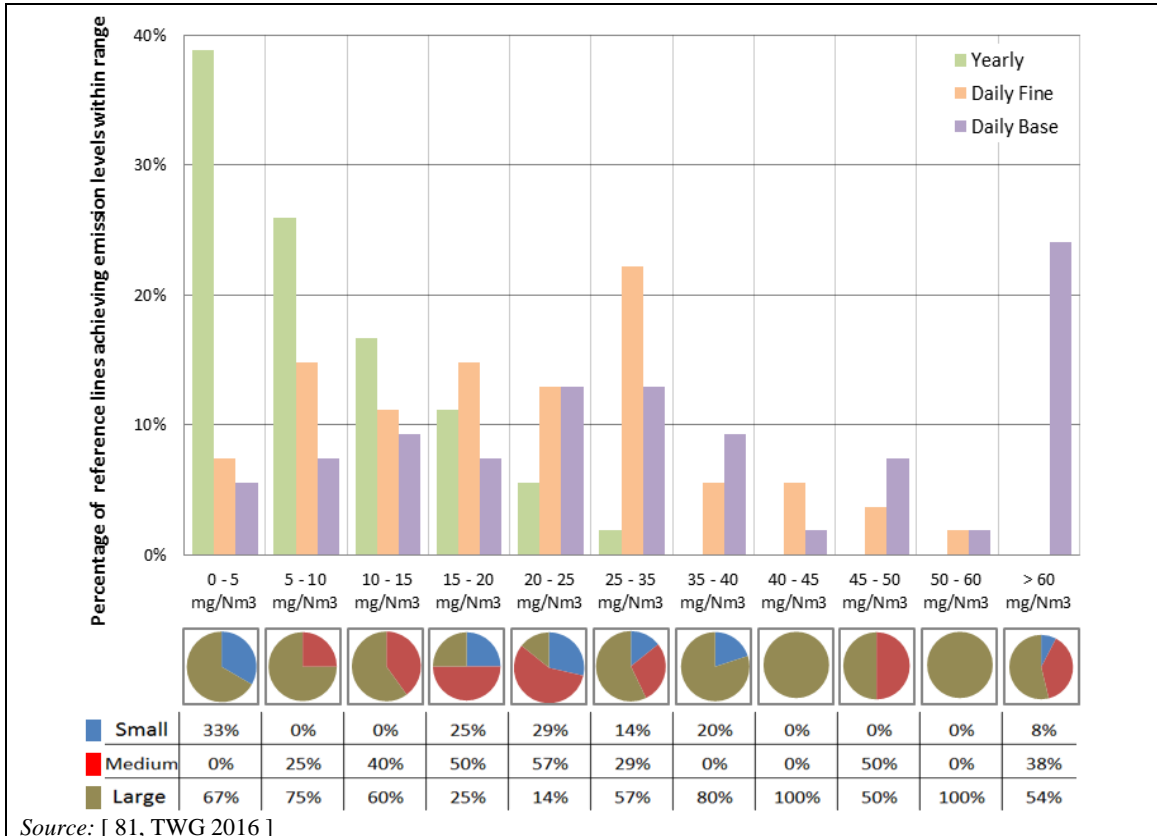

Figure 3.20: Continuously monitored CO emissions to air from reference lines incinerating predominantly ONHW

The emission levels range between 0.5 mg/Nm³ and 31 mg/Nm³ as a yearly average and between 4 mg/Nm³ and 53 mg/Nm³ as a maximum daily average, with the exception of two plants showing negligibly low levels and one plant showing a level of 81 mg/Nm³ as a maximum daily average ('fine' data filtering). Similarly to TVOC emissions, the difference between the maximum daily average and the yearly average tends to be substantial, reflecting the variability of CO emissions when the combustion conditions in the furnace are not stable, e.g. at start-ups and shutdowns. This is also reflected by typically large differences between the maxima of daily averages obtained with 'base' and 'fine' data filtering.

The reported data do not show a clear correlation between the achieved emission levels and the technique installed, the type and amount of reagent used, the age and size of the plant, or the furnace type.

PCDD/F, PCBs and PAHs

For reaching low levels of PCDD/F emissions, primary as well as secondary measures are important. In the firing system, effective mixing of the gases (high turbulence) improves the destruction of PCDD/F and similar compounds already present in the waste. Avoiding the temperature window for the recombination of PCDD/F and similar compounds in the boiler and flue-gas treatment system avoids the *de novo* synthesis of new PCDD/F.

For further reduction, four main types of techniques are in use:

1. Static or moving-bed activated carbon filter.
2. Injection of activated carbon (alone or mixed with other reagents) to be removed in the deduster.
3. Destruction of gaseous PCDD/F on a catalyst, including the case of catalytic filter bags.
4. PCDD/F adsorption in packing elements made of carbon-impregnated polymer material in wet scrubbers or in static beds.

The use of activated carbon has the advantage of also reducing mercury emissions. Catalysts are mainly used to reduce NO_x emissions.

PCDD/F emission data are based on periodic measurements and are shown in the following figures, in simplified form within this chapter and in detail in Annex 8.8:

- Figure 3.21, for 199 reference lines incinerating predominantly MSW and monitoring PCDD/F periodically. Due to the large number of data points represented, the corresponding detailed graphs are divided into three figures for readability. These are Figure 8.112, Figure 8.113 and Figure 8.114.
- Figure 3.22, for 45 reference lines incinerating predominantly ONHW and monitoring PCDD/F periodically. The corresponding detailed graph is Figure 8.115.

For each emission concentration range represented on the horizontal axis, the pie charts underneath show the shares of reference lines, among those achieving emission levels within the given range, that are fitted with a fixed adsorption bed, without a fixed adsorption bed and a wet scrubber, and without a fixed adsorption bed and dry FGC techniques.

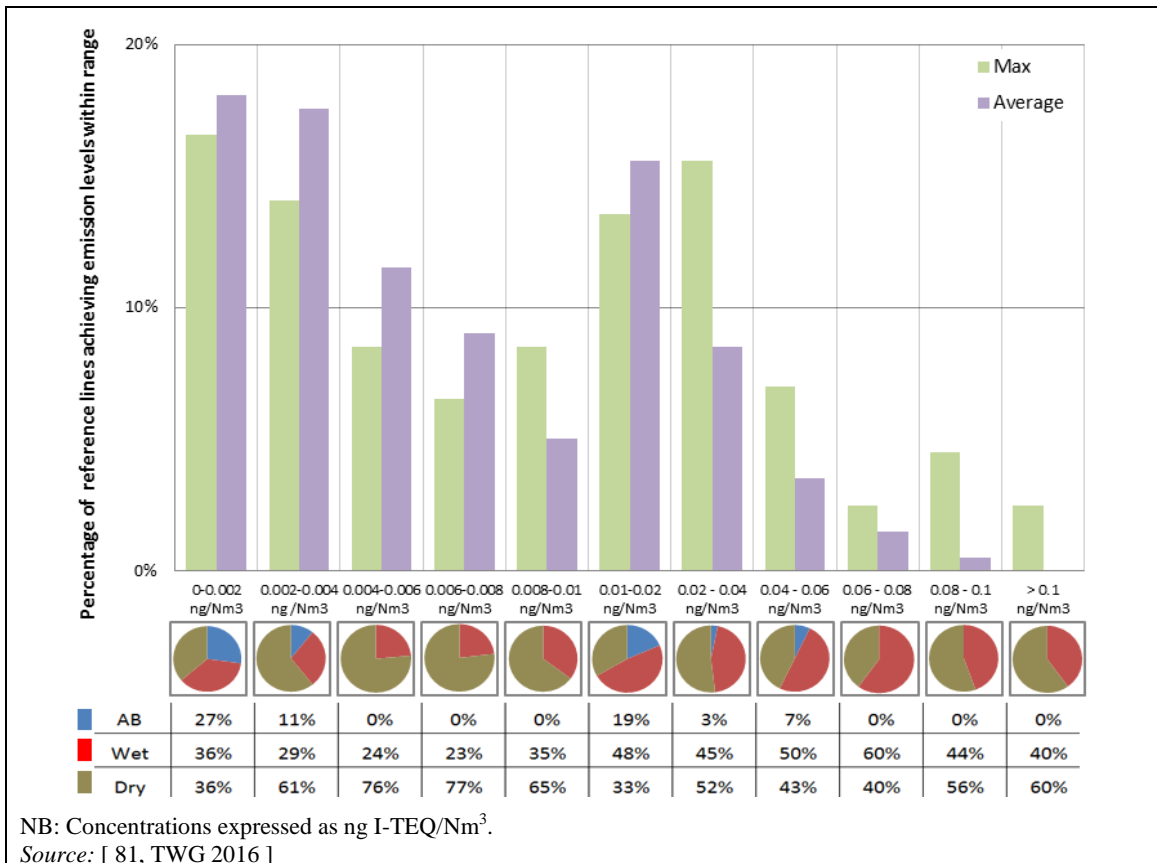

Figure 3.21: Periodically monitored PCDD/F emissions to air from reference lines incinerating predominantly MSW

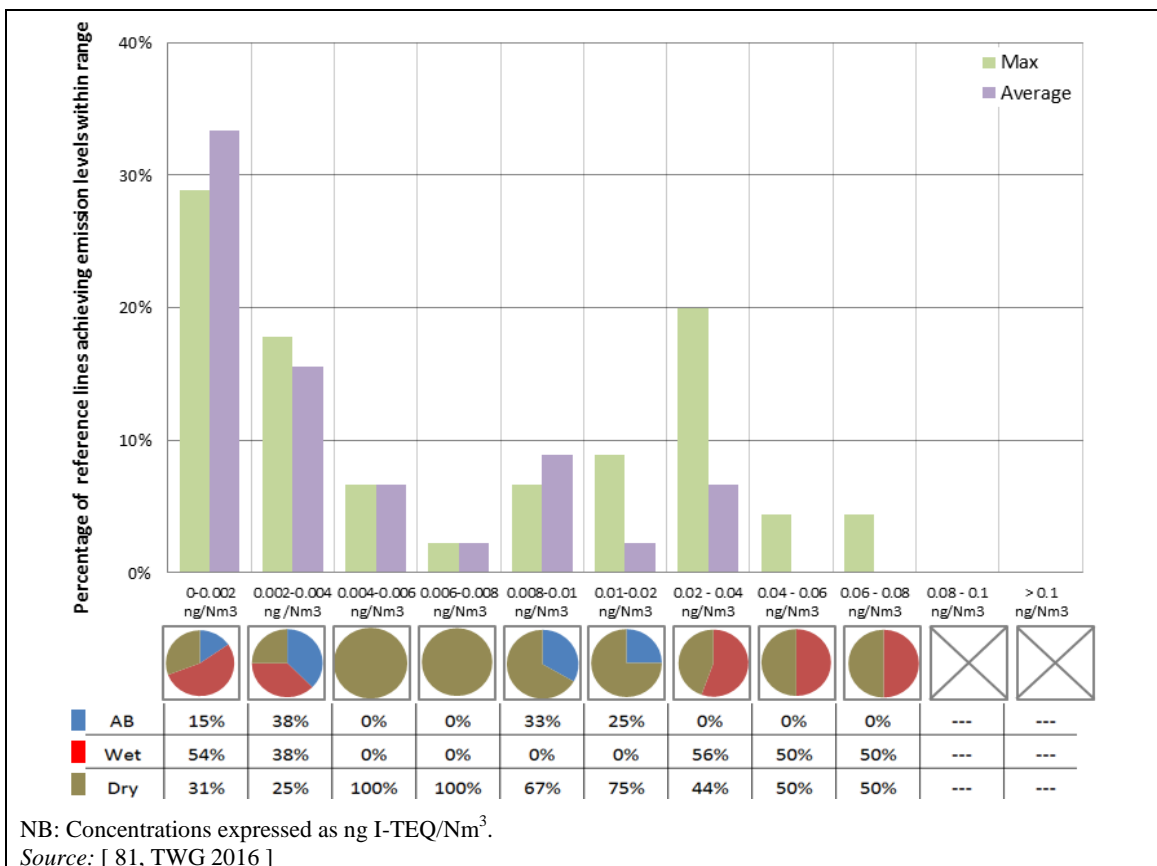

Figure 3.22: Periodically monitored PCDD/F emissions to air from reference lines incinerating predominantly ONHW

The emission levels range between close to the limit of quantification and $0.24 \text{ ng I-TEQ/Nm}^3$, with the vast majority of reference lines showing levels below $0.06 \text{ ng I-TEQ/Nm}^3$. All plants fitted with fixed adsorption bed reported emission levels below $0.05 \text{ ng I-TEQ/Nm}^3$.

The reported data do not show a clear correlation between the achieved emission levels and the type and amount of reagent used, the age and size of the plant, or the furnace type.

The PCDD/F emission data described so far only concern emissions measured periodically with a typical (short-term) sampling time of 6–8 hours. There is however also increasing experience with long-term sampling measurements of PCDD/F emissions sampled during periods of typically 2–4 weeks.

For the purpose of comparing the emission levels measured with short-term and long-term sampling, emission data submitted by 142 reference lines in Belgium and France that performed both long-term and short-term sampling measurements over the same period of time are presented and analysed in Annex 8.9.

Polychlorinated biphenyls (PCBs) and polyaromatic hydrocarbons (PAHs) are removed by the same techniques as PCDD/F, meaning that an effective flue-gas cleaning system for PCDD/F will also deal with PCBs and PAHs.

Dioxin-like PCB emission data, based on periodic measurements, are shown in Annex 8.8 in the following figures:

- Figure 8.116, for 42 reference lines incinerating predominantly MSW;
- Figure 8.117, for 17 reference lines incinerating predominantly ONHW;
- Figure 8.118 shows PCDD/F and dioxin-like PCB emissions together, for the cases where both groups of substances were measured in the same sample, irrespective of the predominant type of waste incinerated.

The emission levels are mostly low and below the levels of PCDD/F. However, there are a substantial number of plants reporting much higher emissions, up to 3 ng WHO-TEQ for MSW and up to 56 ng WHO-TEQ for ONHW. However, these high values are possibly misreported (e.g. not normalised for the TEF).

PAH and BaP emission data are based on periodic measurements and are shown in Annex 8.8 in the following figures:

- Figure 8.119, PAH emissions from 44 reference lines incinerating predominantly MSW;
- Figure 8.120, PAH emissions from 13 reference lines incinerating predominantly ONHW;
- Figure 8.121, BaP emissions from 48 reference lines incinerating predominantly MSW;
- Figure 8.122, BaP emissions from 19 reference lines incinerating predominantly ONHW.

Emission levels range from 0.01 ng/Nm^3 to $50 \text{ } \mu\text{g/Nm}^3$ for PAHs and from 0.004 ng/Nm^3 to $1 \text{ } \mu\text{g/Nm}^3$ for BaP.

Mercury

The vast majority of plants use activated carbon, either as a fixed-bed system or in an entrained flow activated carbon injection system. The consumption rate as well as the quality of activated carbon (e.g. brominated or sulphur-impregnated) directly affect the emission levels. Other less frequently used techniques are the use of zeolites or the capture of mercury in the acidic wet scrubber, which can serve as a sink for mercury if it is present in the Hg(II) chloride form. The

mercury that has been transferred from the gas stream to the scrubber liquor can then be removed by a waste water treatment plant.

If mercury is present in metallic form the use of oxidation agents is needed, such as brominated activated carbon injection or boiler bromine addition (see mercury removal techniques).

[74, TWG 2004]

Under certain conditions (e.g. high input rate of mercury), the removal capacity limits of the FGC systems may be exceeded, leading to temporarily elevated mercury emissions. MSW usually contains low quantities of mercury. However, some short-term high loads may be observed if the buffer capacity or the ability to respond to peak concentrations of the flue-gas cleaning system is exceeded. These are generally associated with the inclusion of batteries, electrical switches, thermometers, laboratory wastes, etc. in the MSW. This may be reflected by cases where the performance levels of a reference line for different averaging periods show large variations.

Mercury emission data are based either on continuous or periodic measurement and are shown in the following figures, in simplified form within this chapter and in detail in Annex 8.6 and Annex 8.8; half-hourly emission levels are shown Annex 8.7:

- Figure 3.23, for the emission levels of 171 reference lines incinerating predominantly MSW and monitoring Hg periodically. Due to the large number of data points represented, the corresponding detailed graphs are divided into three figures for readability. These are Figure 8.123, Figure 8.124 and Figure 8.125.
- Figure 3.24, for the daily and yearly emission levels of 53 reference lines incinerating predominantly MSW and monitoring Hg continuously. The corresponding detailed graph is Figure 8.32.
- Figure 3.25, for the half-hourly emission levels of 53 reference lines incinerating predominantly MSW and monitoring Hg continuously. The corresponding detailed graph is Figure 8.82.
- Figure 3.26, for the monthly emission levels of 53 reference lines incinerating predominantly MSW and monitoring Hg continuously. The corresponding detailed graph is Figure 8.84.
- Figure 3.27, for the emission levels of 35 reference lines incinerating predominantly ONHW and monitoring Hg periodically. The corresponding detailed graph is Figure 8.126.
- Figure 3.28, for the daily and yearly emission levels of 19 reference lines incinerating predominantly ONHW and monitoring Hg continuously. The corresponding detailed graph is Figure 8.83.
- Figure 3.29, for the half-hourly emission levels of 19 reference lines incinerating predominantly ONHW and monitoring Hg continuously. The corresponding detailed graph is Figure 8.85.
- Figure 3.30, for the monthly emission levels of 19 reference lines incinerating predominantly ONHW and monitoring Hg continuously. The corresponding detailed graph is Figure 8.33.

For each emission concentration range represented on the horizontal axis, the pie charts underneath show the shares of reference lines, among those achieving emission levels within the given range, that are fitted with a fixed adsorption bed, without a fixed adsorption bed and a wet scrubber, and a without fixed adsorption bed and dry FGC techniques.

The monthly levels presented in Figure 3.26 and Figure 3.30 are derived based on continuous monitoring data and provide an indication of the emission levels achieved when measuring mercury with an averaging period typical of long-term sampling methods. For monthly levels, which are hardly affected by short-term peaks, only the 'base' filtering mode is presented.

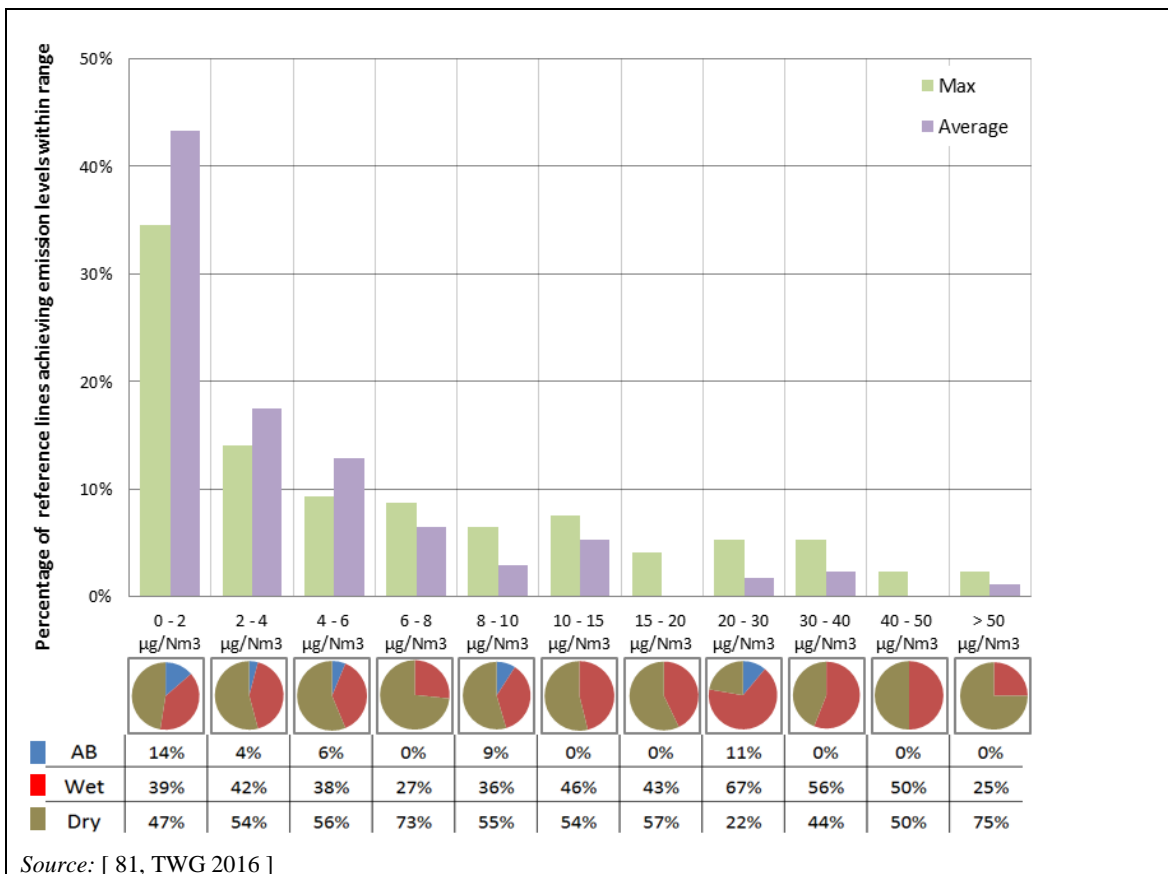

Figure 3.23: Periodically monitored mercury emissions to air from reference lines incinerating predominantly MSW

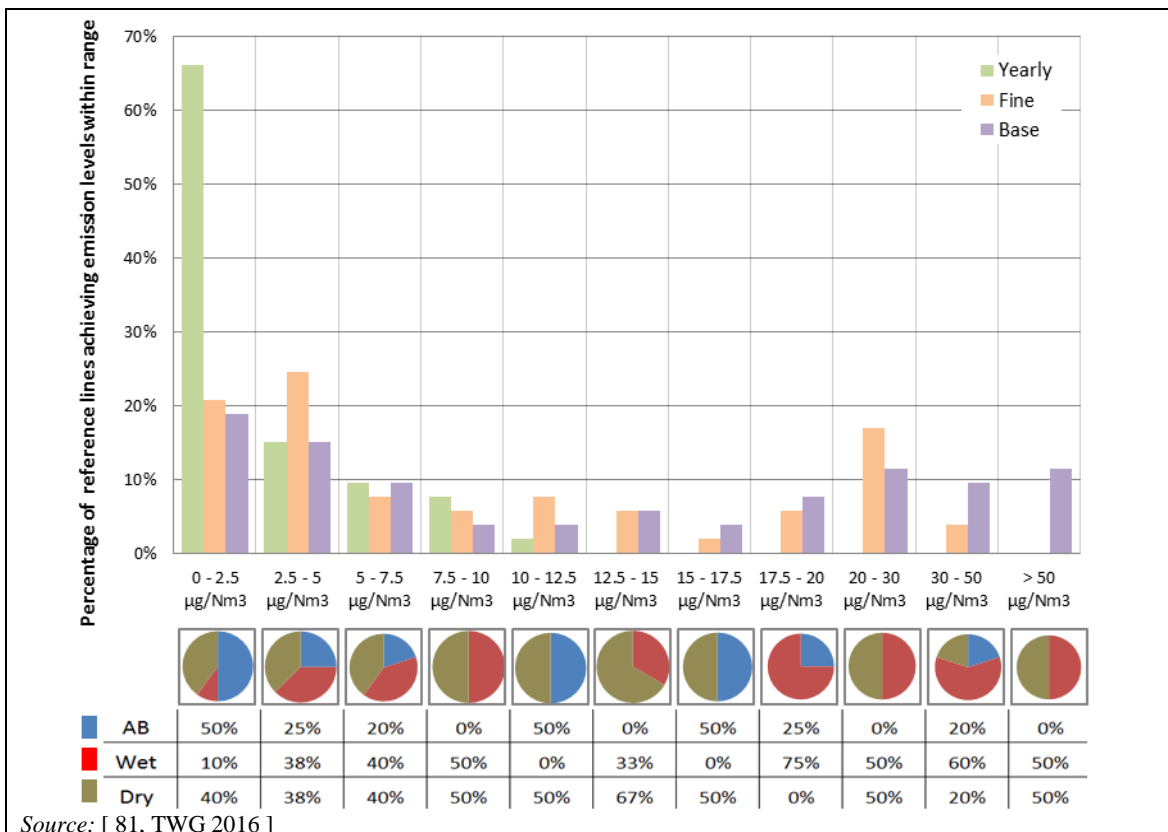
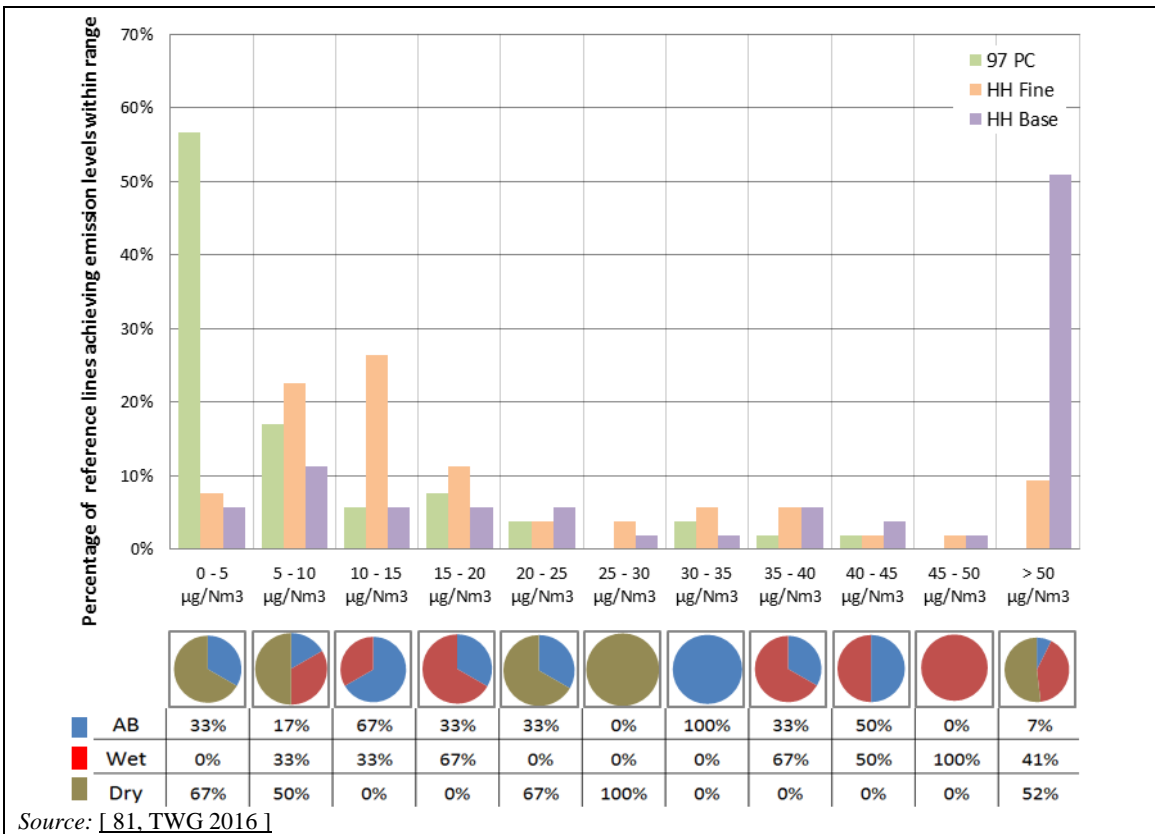
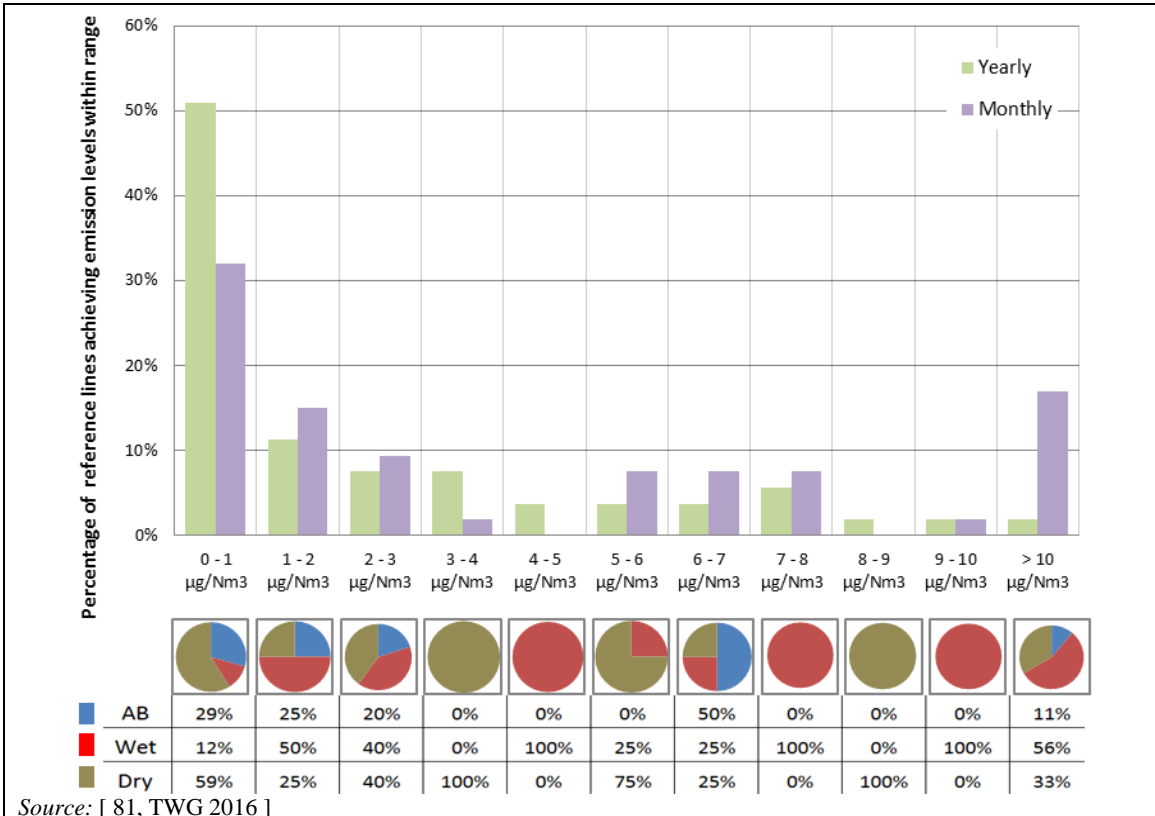

Figure 3.24: Continuously monitored mercury emissions to air from reference lines incinerating predominantly MSW: daily and yearly emission levels



Source: [81, TWG 2016]

Figure 3.25: Continuously monitored mercury emissions to air from reference lines incinerating predominantly MSW: half-hourly emission levels



Source: [81, TWG 2016]

Figure 3.26: Continuously monitored mercury emissions to air from reference lines incinerating predominantly MSW: monthly emission levels

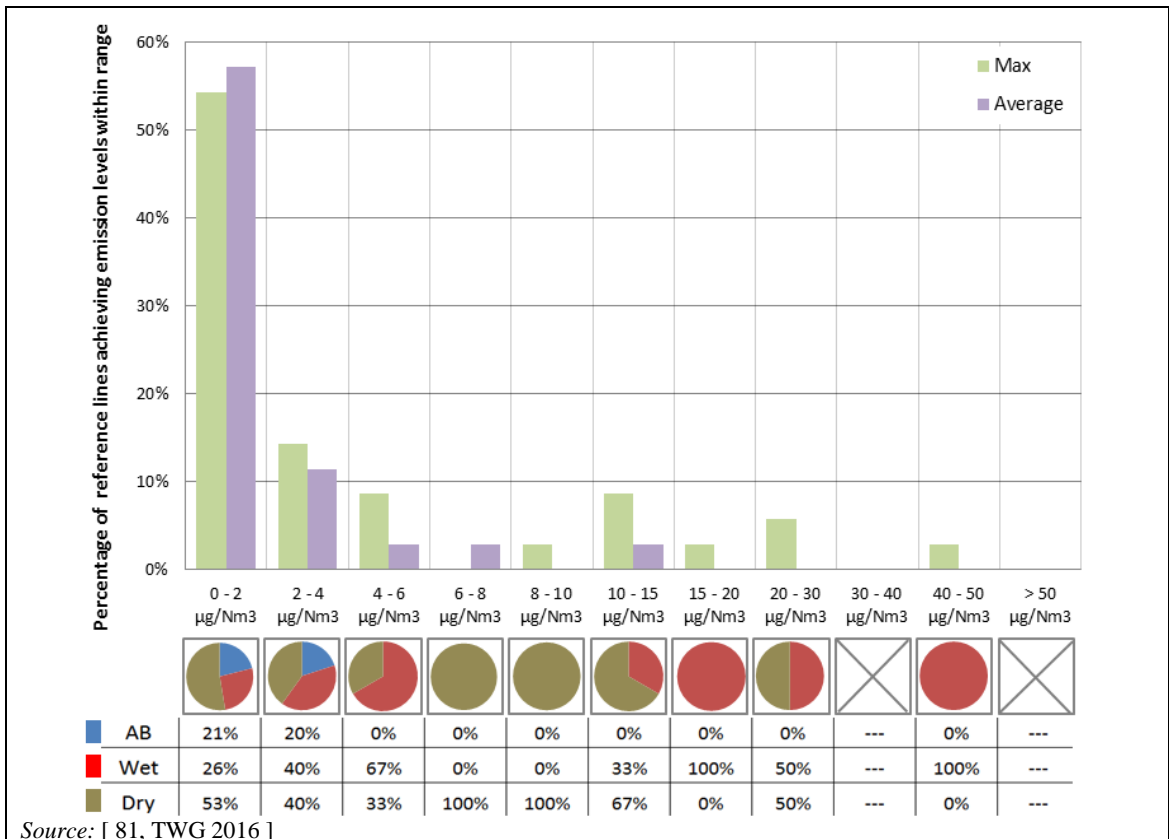

Figure 3.27: Periodically monitored mercury emissions to air from reference lines incinerating predominantly ONHW

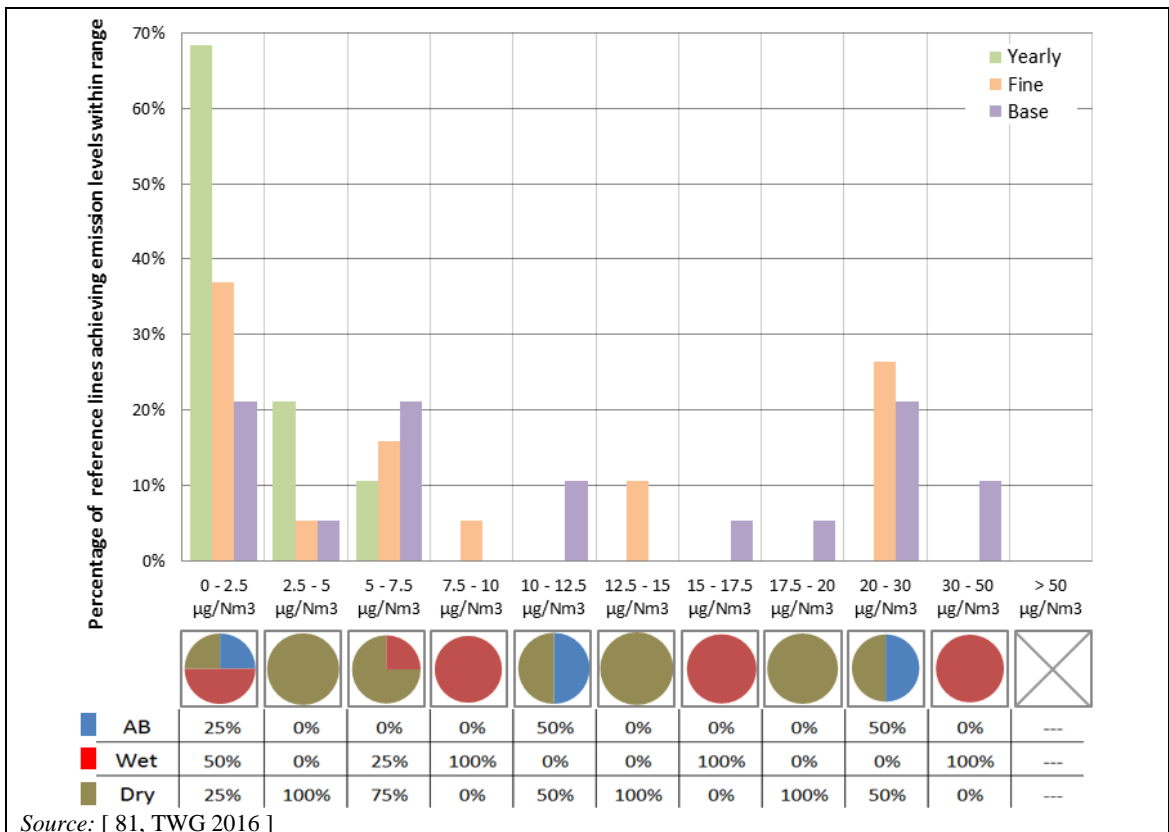
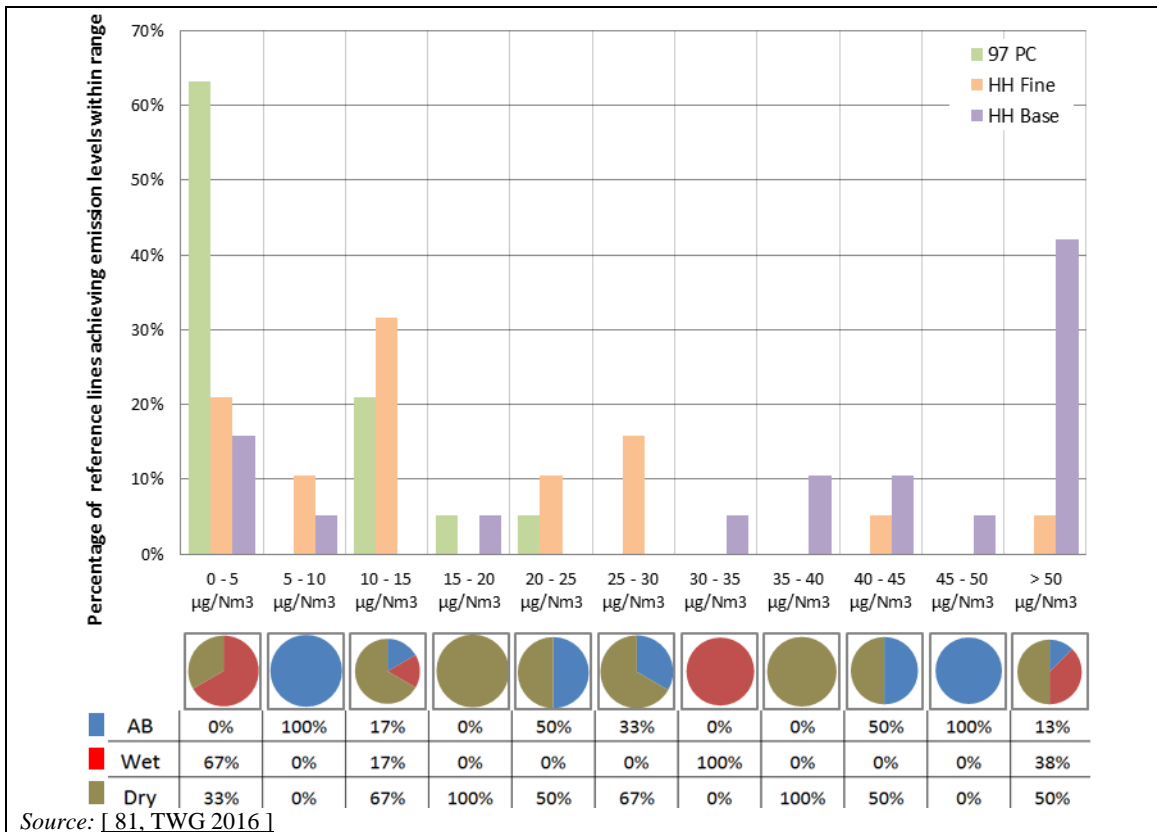
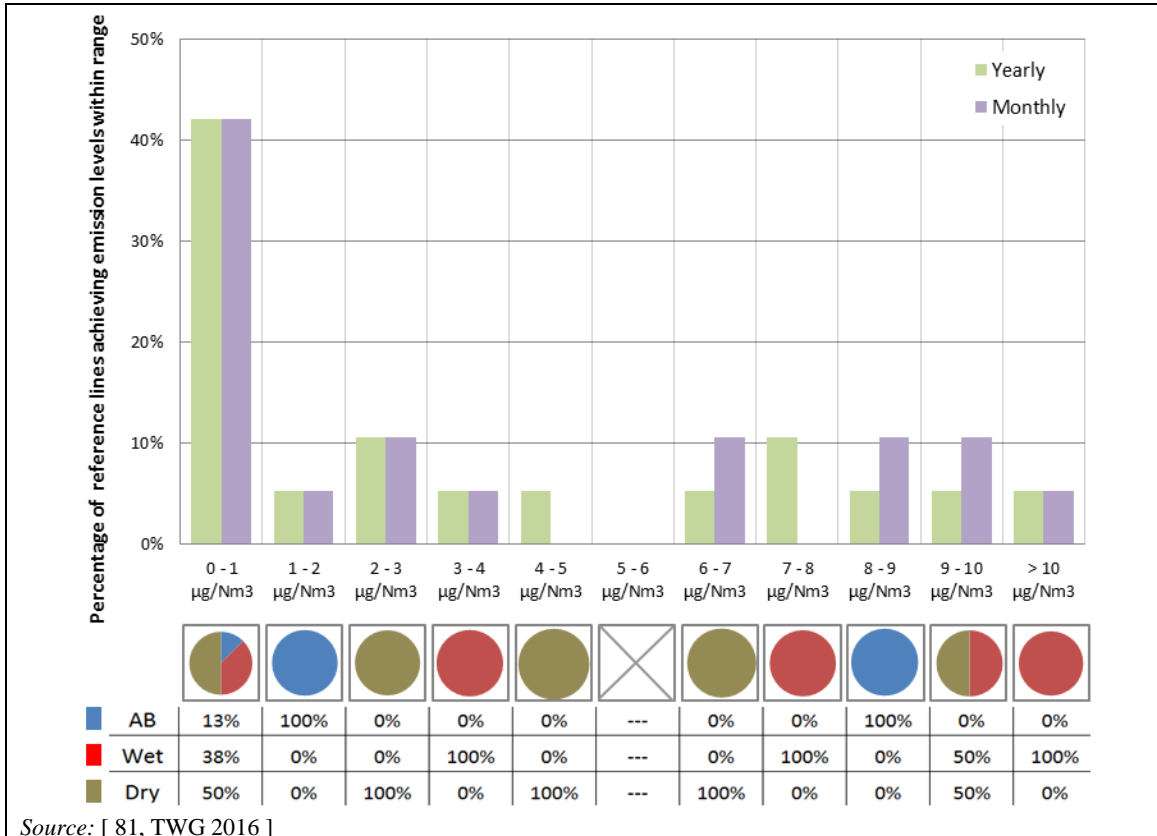

Figure 3.28: Continuously monitored mercury emissions to air from reference lines incinerating predominantly ONHW: daily and yearly emission levels



Source: [81, TWG 2016]

Figure 3.29: Continuously monitored mercury emissions to air from reference lines incinerating predominantly ONHW: half-hourly emission levels



Source: [81, TWG 2016]

Figure 3.30: Continuously monitored mercury emissions to air from reference lines incinerating predominantly ONHW: monthly emission levels

The emission levels range between close to the limit of quantification and 0.01 mg/Nm^3 as a yearly average, 0.018 mg/Nm^3 as a maximum monthly average, and 0.036 mg/Nm^3 as a maximum daily average ('fine' data filtering). In certain cases the maximum daily average obtained with 'base' data filtering may be substantially higher (up to 0.09 mg/Nm^3), which may reflect not only high mercury input episodes, but also OTNOC situations where the daily average typically includes only a few half-hourly periods and where the mercury levels measured are elevated. Plants that measure mercury periodically report averages over the sampling period generally below 0.025 mg/Nm^3 , with a few exceptions that include plants not reporting the use of reagents to control mercury emissions.

The plants fitted with a fixed adsorption bed generally report emission levels that are stable with maximum daily averages relatively insensitive to data filtering, mostly below 0.01 mg/Nm^3 and in all cases below 0.025 mg/Nm^3 . These levels are also maintained as averages over the sampling period reported by plants that measure mercury periodically.

The reported data do not show a clear correlation between the achieved emission levels and the type and amount of reagent used, the age and size of the plant, or the furnace type.

Antimony, arsenic, chromium, cobalt, copper, lead, manganese, nickel and vanadium

The techniques used to remove dust are the main ones also used to reduce the emissions of dust-bound metals. [Sb+As+Cr+Co+Cu+Pb+Mn+Ni+V] emission data are based on periodic measurements and are shown in the following figures, in simplified form within this chapter and in detail in Annex 8.8:

- Figure 3.31, for 205 reference lines incinerating predominantly MSW and monitoring Sb+As+Cr+Co+Cu+Pb+Mn+Ni+V emissions periodically. Due to the large number of data points represented, the corresponding detailed graph is divided into three figures for readability. These are Figure 8.127, Figure 8.128 and Figure 8.129.
- Figure 3.32, for 54 reference lines incinerating predominantly ONHW and monitoring Sb+As+Cr+Co+Cu+Pb+Mn+Ni+V emissions periodically. The corresponding detailed graph is Figure 8.130.

For each emission concentration range represented on the horizontal axis, the pie charts underneath show the shares of reference lines, among those achieving emission levels within the given range, that are fitted with a bag filter and with other techniques (such as ESPs).

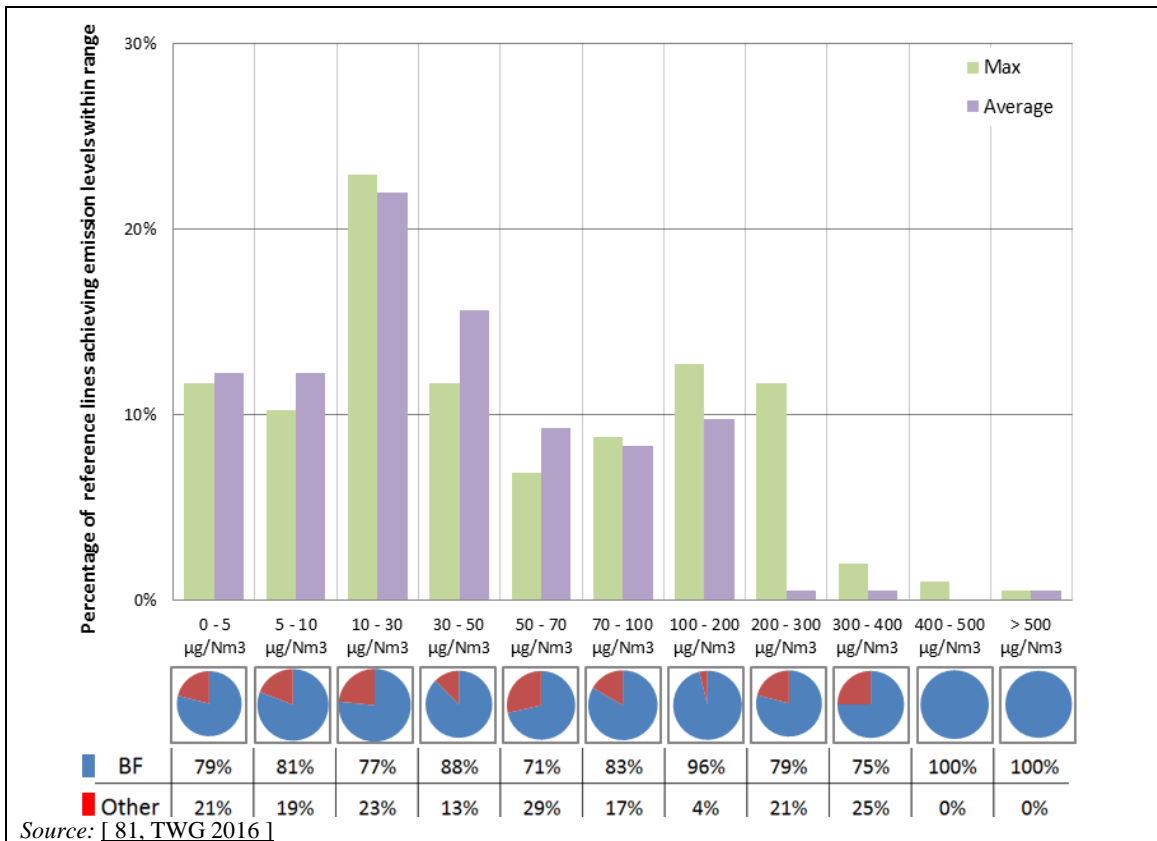

Figure 3.31: Periodically monitored Sb+As+Cr+Co+Cu+Pb+Mn+Ni+V emissions to air from reference lines incinerating predominantly MSW

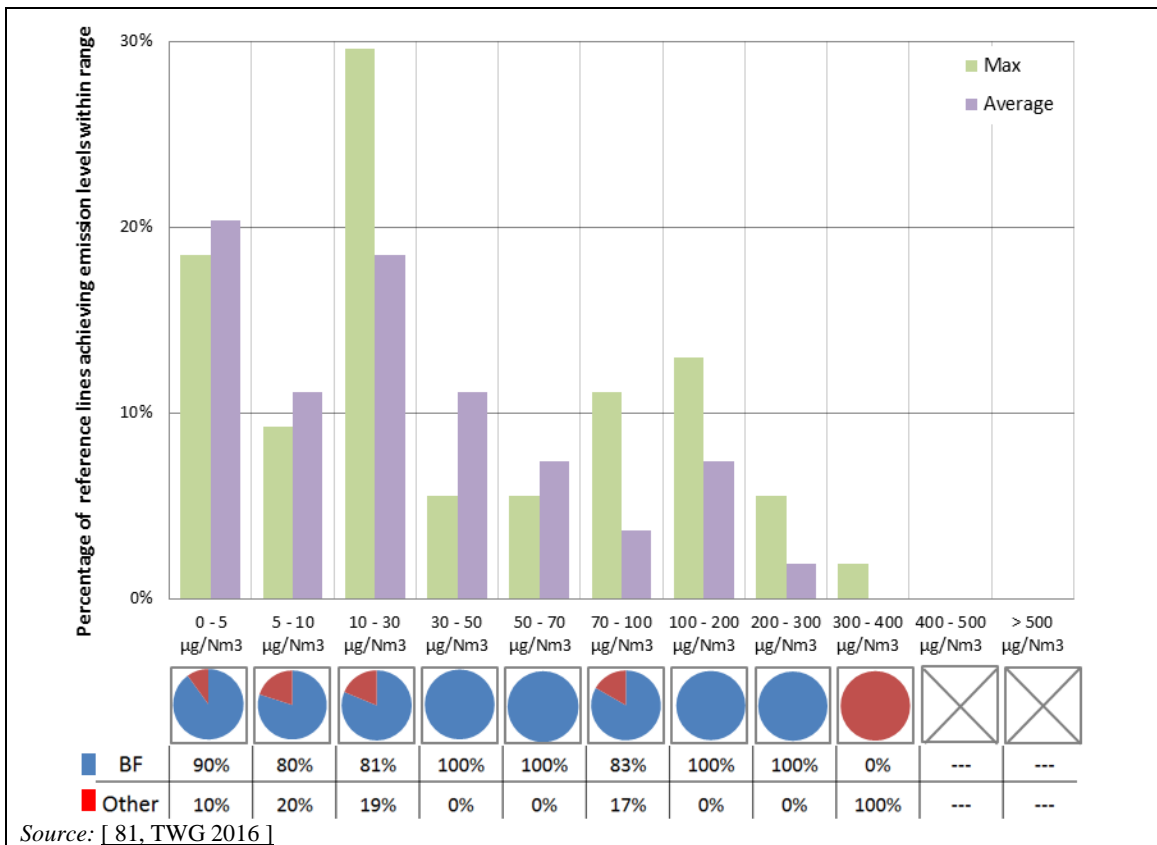

Figure 3.32: Periodically monitored Sb+As+Cr+Co+Cu+Pb+Mn+Ni+V emissions to air from reference lines incinerating predominantly ONHW

The emission levels range between close to the limit of quantification and 0.3 mg/Nm^3 , with the exception of six reference lines showing levels between 0.3 mg/Nm^3 and 0.5 mg/Nm^3 , as a maximum of the averages over the sampling period; one reference line reported a maximum level of around 5 mg/Nm^3 .

The reported data do not show a clear correlation between the achieved emission levels and the technique installed, the age and size of the plant, or the furnace type.

Cadmium and thallium

The techniques used to remove dust are the main ones also used to reduce the emissions of dust-bound metals. [Cd+Tl] emission data are based on periodic measurements and are shown in the following figures, in simplified form within this chapter and in detail in Annex 8.8:

- Figure 3.33, for 197 reference lines incinerating predominantly MSW and monitoring Cd+Tl emissions periodically. Due to the large number of data points represented, the corresponding detailed graph is divided into three figures for readability. These are Figure 8.131, Figure 8.132 and Figure 8.133.
- Figure 3.34, for 45 reference lines incinerating predominantly ONHW and monitoring Cd+Tl emissions periodically. The corresponding detailed graph is Figure 8.134.

For each emission concentration range represented on the horizontal axis, the pie charts underneath show the shares of reference lines, among those achieving emission levels within the given range, that are fitted with a bag filter and with other techniques (such as ESPs).

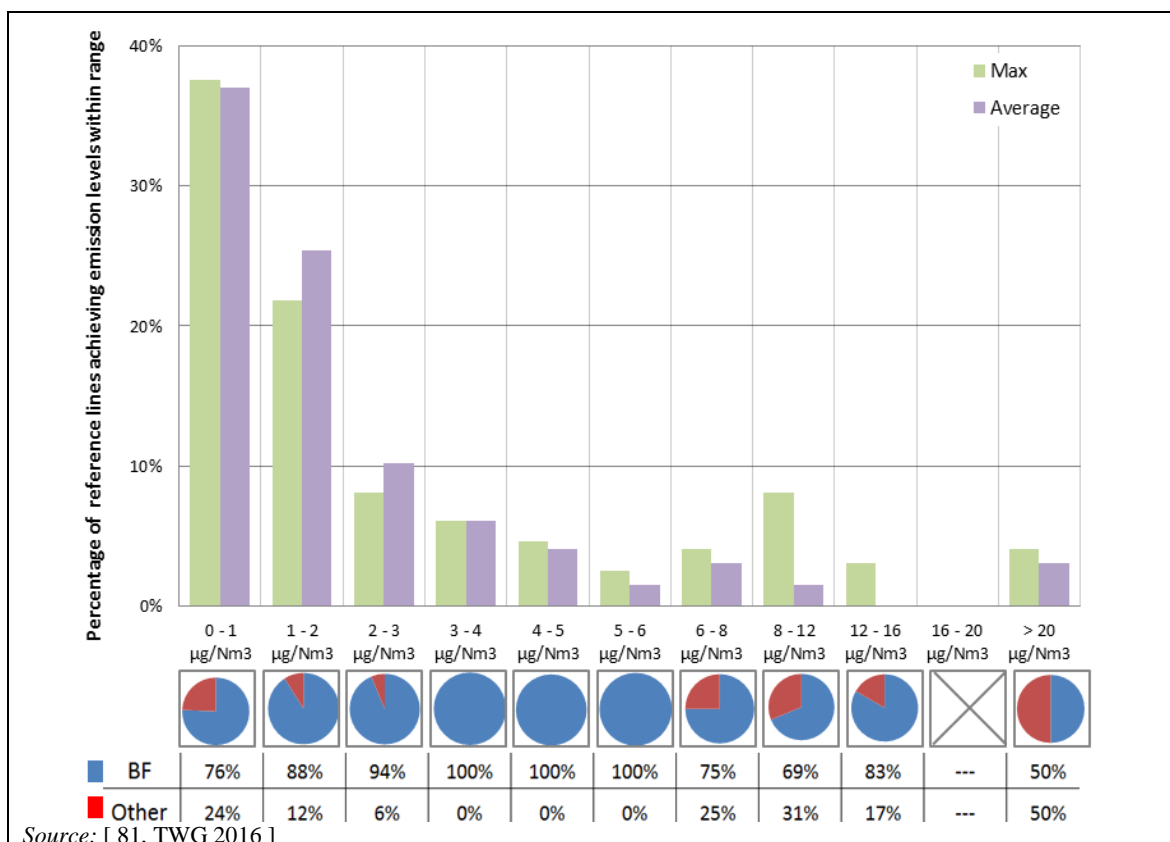

Figure 3.33: Periodically monitored Cd+Tl emissions to air from reference lines incinerating predominantly MSW

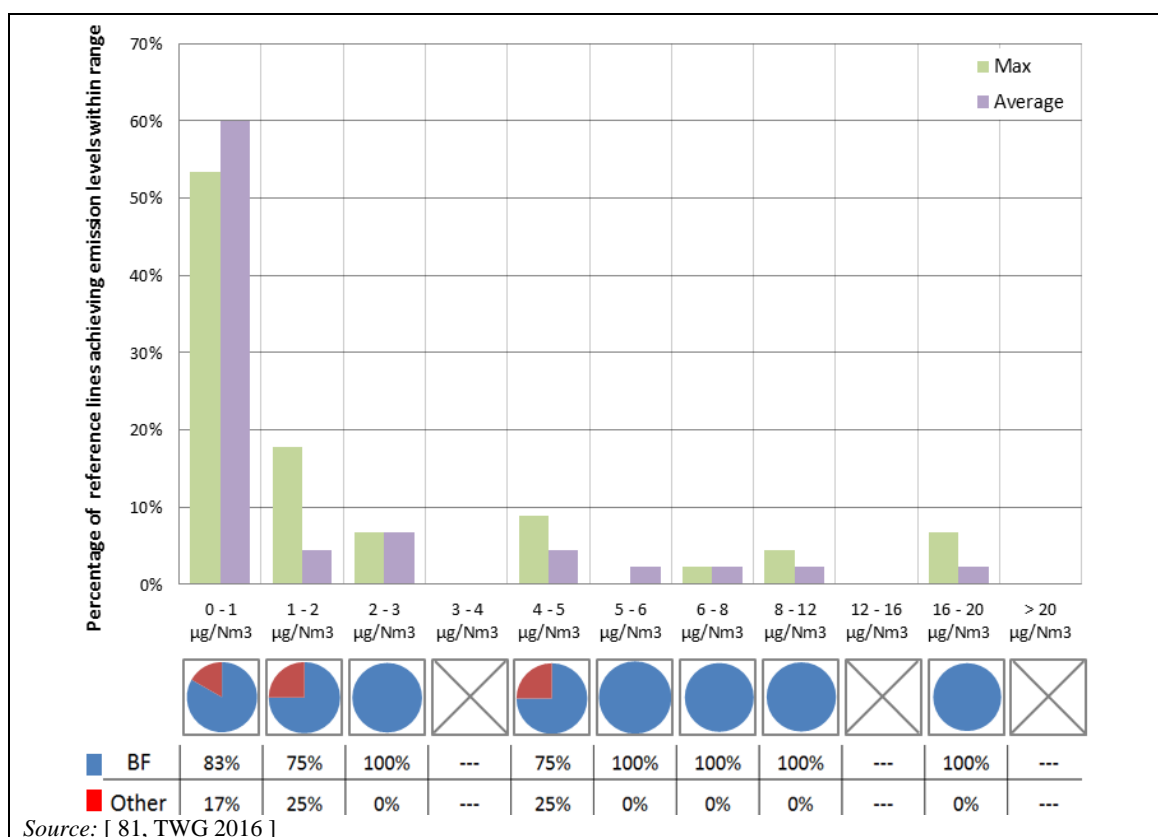

Figure 3.34: Periodically monitored Cd+Tl emissions to air from reference lines incinerating predominantly ONHW

The emission levels are almost always very low and range between close to the limit of quantification and 0.02 mg/Nm^3 , with the exception of six reference lines showing levels between 0.02 mg/Nm^3 and 0.1 mg/Nm^3 , as a maximum of the averages over the sampling period; one reference line reported a maximum level above 1 mg/Nm^3 .

The reported data do not show a clear correlation between the achieved emission levels and the technique installed, the age and size of the plant, or the furnace type.

3.2.2.2 Emissions to air from the incineration of sewage sludge

Hydrogen chloride and hydrogen fluoride

Sewage sludge (SS) incineration plants that participated in the 2016 data collection are fitted either with wet or dry systems; none of the plants reported the use of semi-wet or semi-dry systems.

HCl emission data from 17 reference lines incinerating predominantly SS, based on continuous measurements, are shown in Figure 3.35 in simplified form. The corresponding detailed graphs are Figure 8.34 of Annex 8.6 for daily and yearly emission levels, and Figure 8.86 of Annex 8.7 for half-hourly emission levels.

For each emission concentration range represented on the horizontal axis, the pie charts underneath show the shares of reference lines, among those achieving emission levels within the given range, that are fitted with a wet scrubber and with other techniques (mainly DSI).

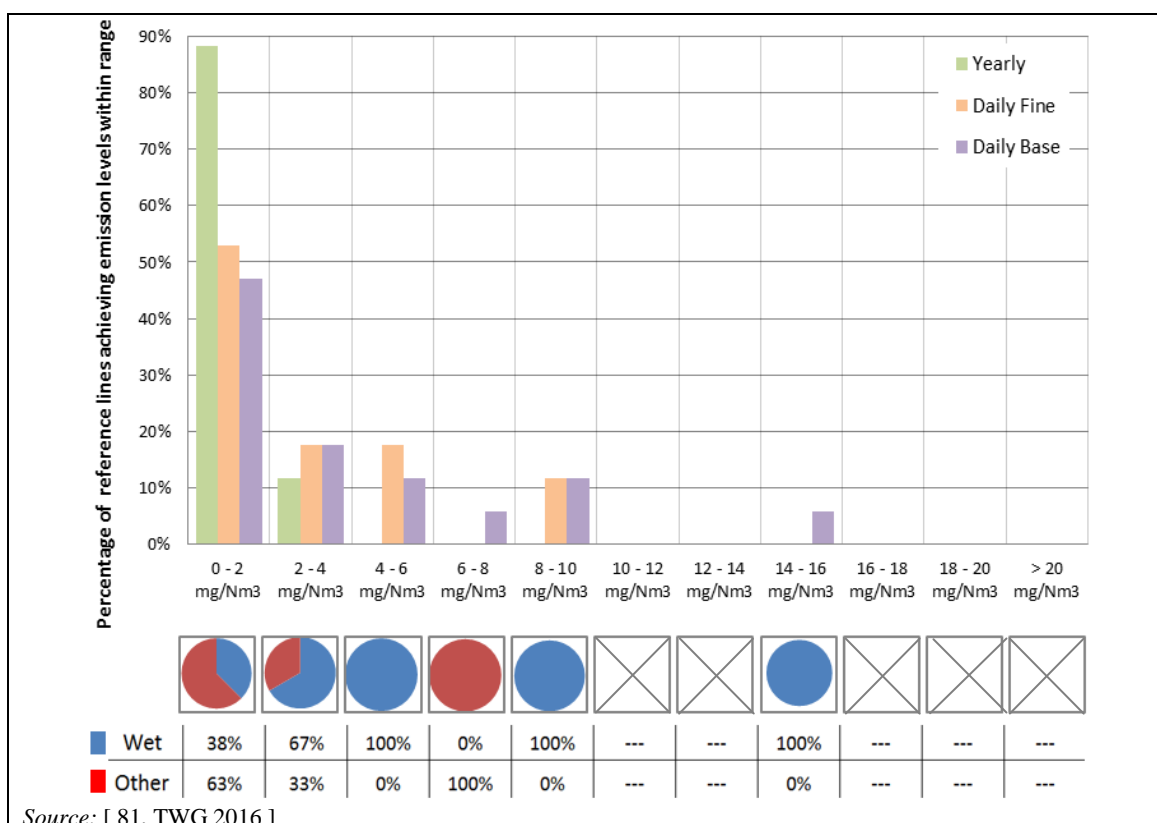

Figure 3.35: Continuously monitored HCl emissions to air from reference lines incinerating predominantly SS

The emission levels range between close to the limit of quantification and 8 mg/Nm^3 as a yearly average and 10 mg/Nm^3 as a maximum daily average ('fine' data filtering). In most cases the maximum daily average obtained with 'base' data filtering does not substantially change from the value obtained with 'fine' data filtering; the most notable exception is plant DE87.2R where the maximum daily average rises from 5.8 mg/Nm^3 to 14.8 mg/Nm^3 on a day where emissions recorded at start-up are substantially higher than usual levels and the daily average includes only a limited number of half-hourly periods.

The reported data do not show a clear correlation between the achieved emission levels and the type and amount of reagent used or the age and size of the plant. All plants are fluidised bed incinerators.

Hydrogen fluoride (HF) emission data, based either on continuous or periodic measurements, are shown in the following figures, in simplified form within this chapter and in detail in Annex 8.6 and Annex 8.8; half-hourly emission levels are shown Annex 8.7:

- Figure 3.36, for 6 reference lines incinerating predominantly SS and monitoring HF periodically. The corresponding detailed graph is Figure 8.135.
- Figure 3.37, for 7 reference lines incinerating predominantly SS and monitoring HF continuously. The corresponding detailed graphs are Figure 8.35 for daily and yearly emission levels, and Figure 8.87 for half-hourly emission levels.

For each emission concentration range represented on the horizontal axis, the pie charts underneath show the shares of reference lines, among those achieving emission levels within the given range, that are fitted with a wet scrubber and with other techniques (mainly DSI).

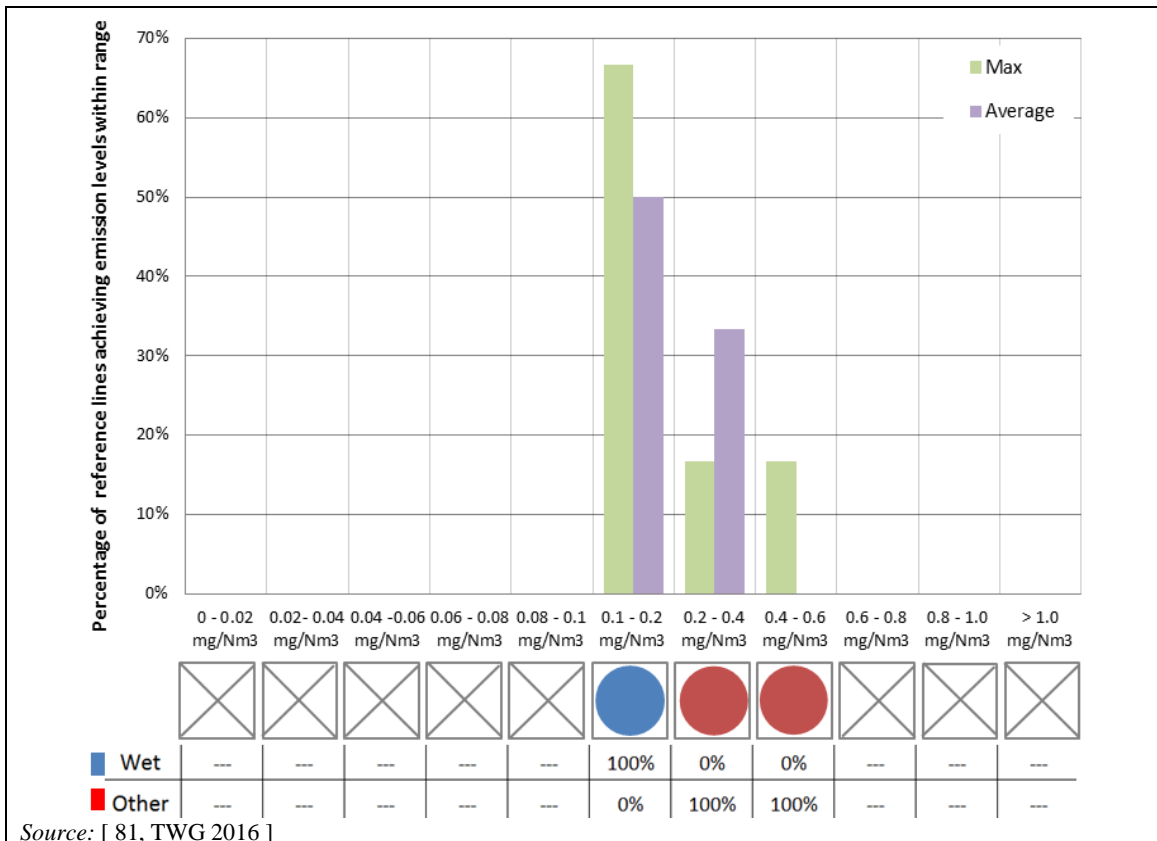

Figure 3.36: Periodically monitored HF emissions to air from reference lines incinerating predominantly SS

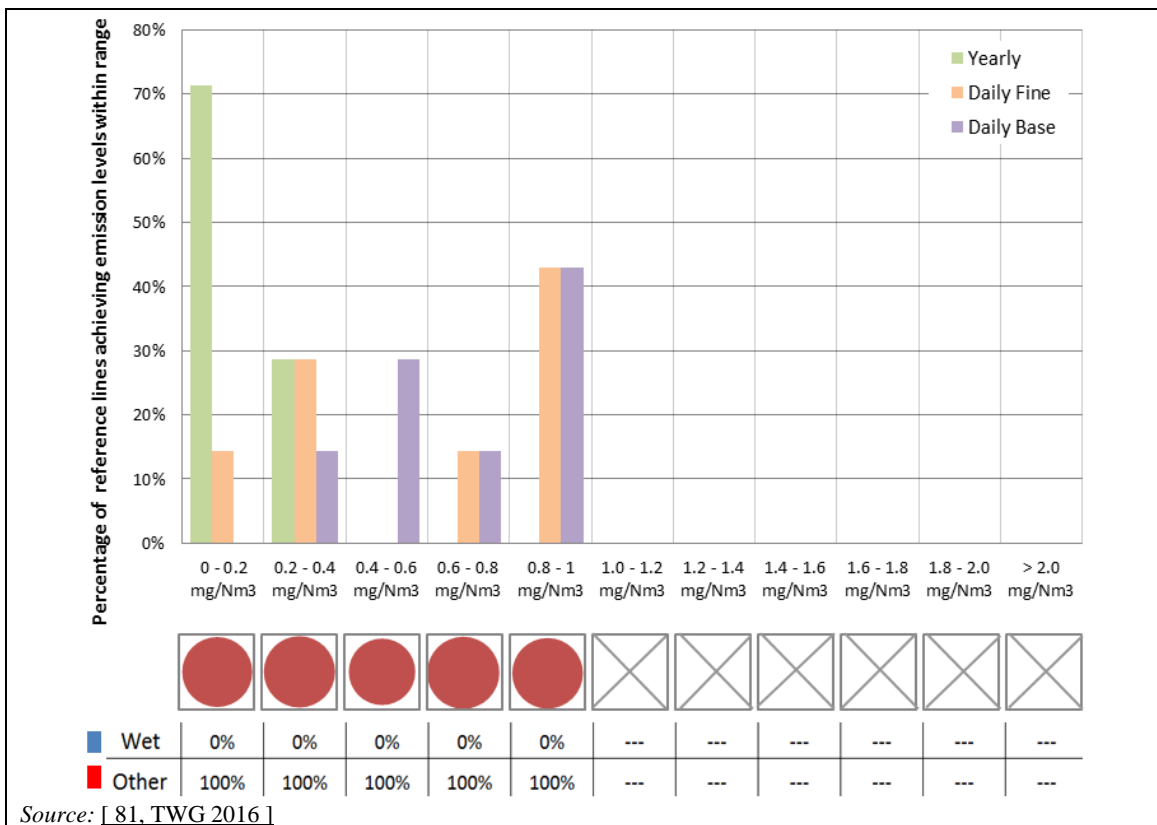

Figure 3.37: Continuously monitored HF emissions to air from reference lines incinerating predominantly SS

The emission levels range between close to the limit of quantification and 0.3 mg/Nm^3 as a yearly average and 1.2 mg/Nm^3 as a maximum daily average or average over the sampling period. The maximum daily average obtained with 'base' data filtering does not substantially change from the value obtained with 'fine' data filtering. One plant shows an emission level above 1 mg/Nm^3 (1.2 mg/Nm^3 as a maximum daily average), whereas the remaining plants have maximum daily averages below 0.9 mg/Nm^3 .

Mostly, plants monitoring HF continuously are fitted with DSI and use NaHCO_3 as a reagent, while plants monitoring HF periodically are commonly fitted with DSI or WS and mostly use NaOH as a reagent.

The reported data do not show a clear correlation between the achieved emission levels and the age and size of the plant. All plants are fluidised bed incinerators.

Sulphur dioxide

The types of flue-gas cleaning systems in use are the same as those for HCl , with the main difference that wet scrubbers are operated at a slightly basic pH (usually 7–8).

SO_2 emission data from 17 reference lines incinerating predominantly SS, based on continuous measurements, are shown in Figure 3.38 in simplified form. The corresponding detailed graphs are Figure 8.36 of Annex 8.6 for daily and yearly emission levels, and Figure 8.88 of Annex 8.7 for half-hourly emission levels.

For each emission concentration range represented on the horizontal axis, the pie charts underneath show the shares of reference lines, among those achieving emission levels within the given range, that are fitted with a wet scrubber and with other techniques (mainly DSI).

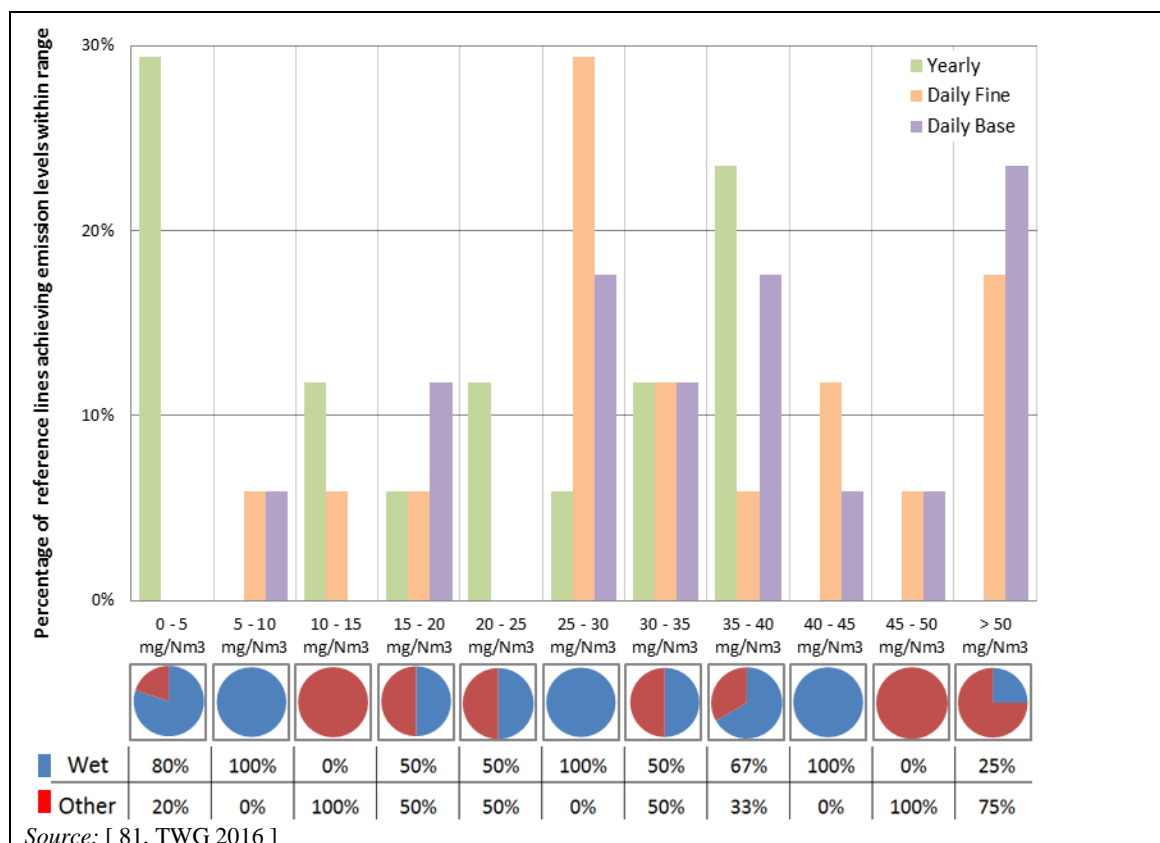

Figure 3.38: Continuously monitored SO_2 emissions to air from reference lines incinerating predominantly SS

The emission levels range between close to the limit of quantification and 40 mg/Nm^3 as a yearly average and 72 mg/Nm^3 as a maximum daily average. The graph shows that the plants fitted with a combination of DSI and WS techniques generally achieve emission levels below 30 mg/Nm^3 as a maximum daily average.

The reported data do not show a clear correlation between the achieved emission levels and the type and amount of reagent used or the age and size of the plant. All plants are fluidised bed incinerators.

Dust

Sewage sludge incineration plants that participated in the 2016 data collection are fitted either with an electrostatic precipitator (ESP) or with a bag filter (BF) for the reduction of dust emissions.

In several cases, both techniques are combined, for example an electrostatic precipitator for pre-dedusting after the boiler with a bag filter before the stack. This allows the separation of fly ash from FGC residues and separate recycling/disposal. Some plants also use cyclones or multi-cyclones for pre-dedusting.

Wet scrubbers and fixed adsorption beds can also contribute to dust removal.

Interdependencies between different parts of the system are frequently seen in the overall flue-gas cleaning system design. For instance, in the case of dry and semi-wet systems, bag filters also act as a reactor for acid gas removal. In addition, they can enable the removal of PCDD/F and metals (including mercury and cadmium) if a suitable reagent is used (e.g. activated carbon).

Dust emission data from 16 reference lines incinerating predominantly SS, based on continuous measurements, are shown in Figure 3.39 in simplified form. The corresponding detailed graphs are Figure 8.37 of Annex 8.6 for daily and yearly emission levels, and Figure 8.89 of Annex 8.7 for half-hourly emission levels.

For each emission concentration range represented on the horizontal axis, the pie charts underneath show the shares of reference lines, among those achieving emission levels within the given range, that are fitted with a bag filter and with other techniques (such as ESPs).

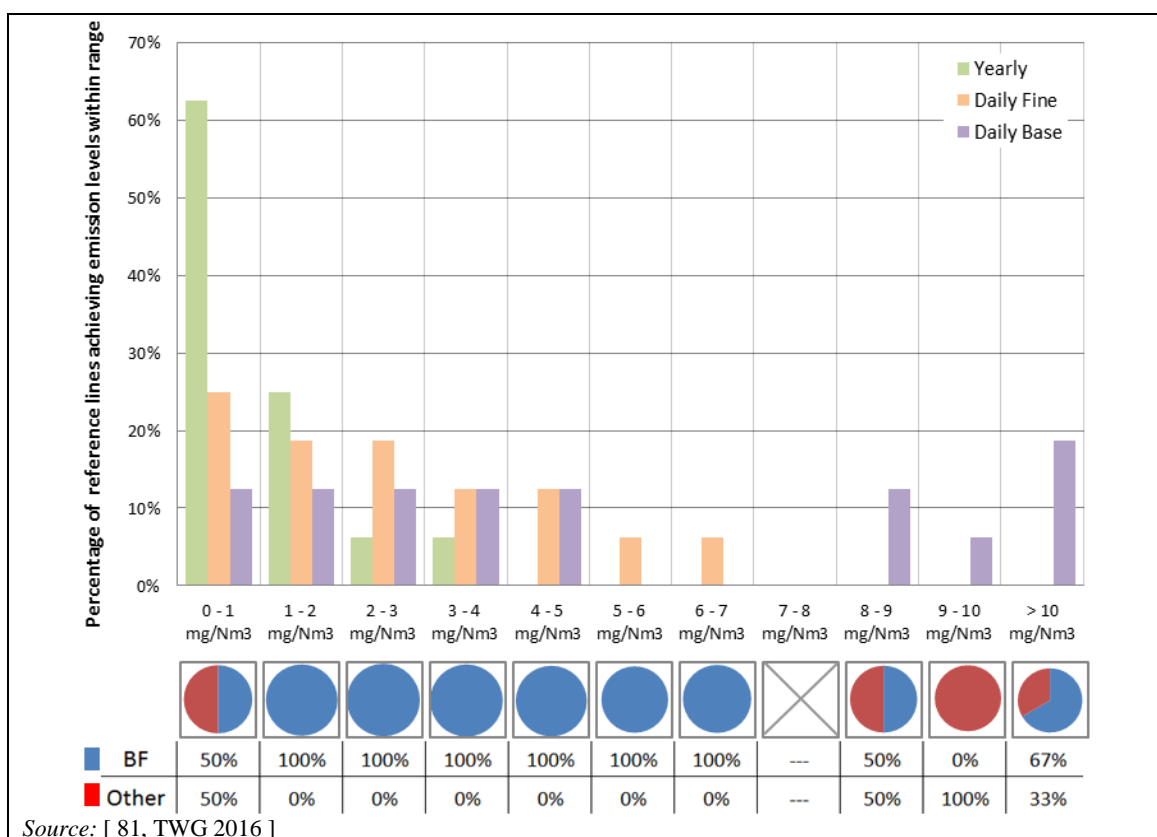

Figure 3.39: Continuously monitored dust emissions to air from reference lines incinerating predominantly SS

The emission levels range between close to the limit of quantification and 3.4 mg/Nm³ as a yearly average and 6.2 mg/Nm³ as a maximum daily average ('fine' data filtering). In some cases the maximum daily average obtained with 'base' data filtering may be substantially higher, generally related to OTNOC situations. The graph shows that all plants with maximum daily average levels above 3.7 mg/Nm³ ('fine' data filtering) are small plants of recent construction, while all plants of a medium and large size achieve lower levels. All plants are fluidised bed incinerators.

Nitrogen oxides

The fluidised bed incineration process used in sewage sludge incinerators provides for lower NO_x levels than other furnace types. Around 60 % of the sewage sludge incinerators that participated in the 2016 data collection use SCR and/or SNCR as secondary techniques for the further reduction of NO_x emissions.

NO_x emission data from 17 reference lines incinerating predominantly SS, based on continuous measurements, are shown in Figure 3.40 in simplified form. The corresponding detailed graphs are Figure 8.38 of Annex 8.6 for daily and yearly emission levels, and Figure 8.90 of Annex 8.7 for half-hourly emission levels.

For each emission concentration range represented on the horizontal axis, the pie charts underneath show the shares of reference lines, among those achieving emission levels within the given range, that are fitted with SCR, with SNCR but no SCR, and with primary techniques at most.

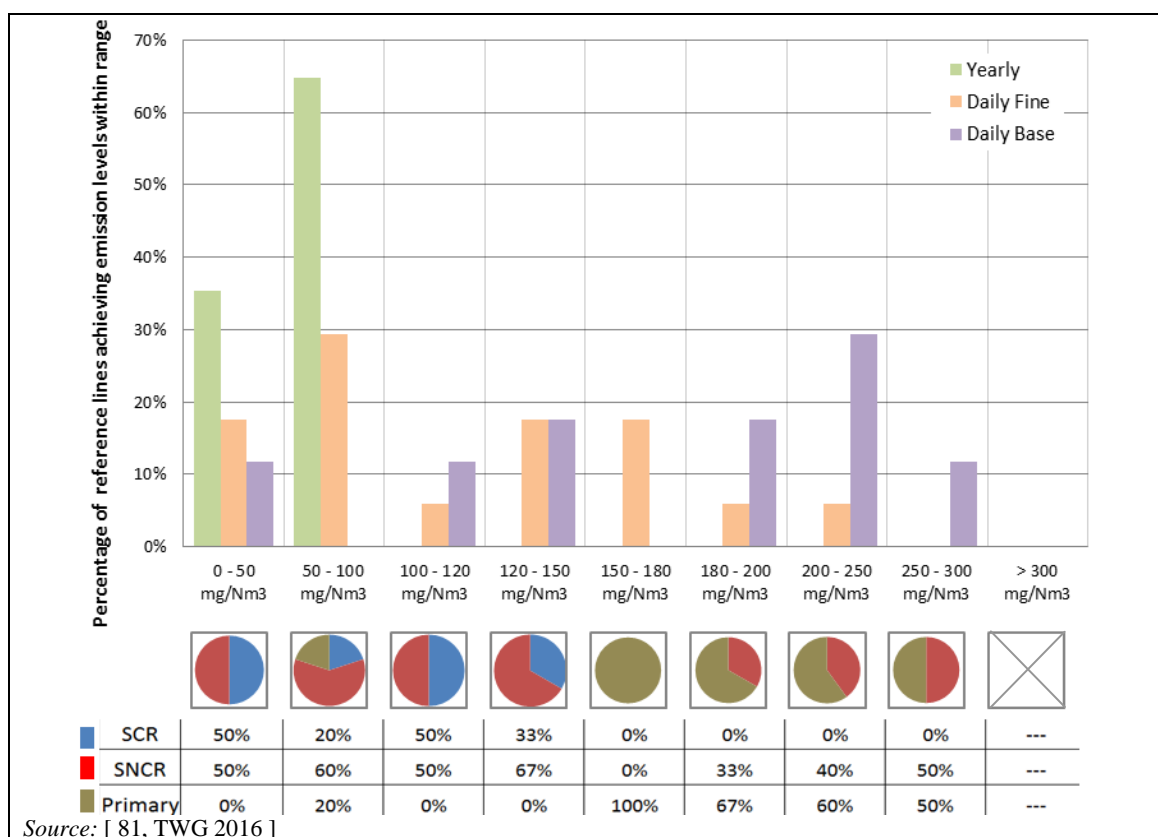

Figure 3.40: Continuously monitored NO_x emissions to air from reference lines incinerating predominantly SS

The emission levels range between 12 mg/Nm³ and 223 mg/Nm³ as a yearly average and between 20 mg/Nm³ and 233 mg/Nm³ as a maximum daily average ('fine' data filtering). Values above 140 mg/Nm³ are observed in plants fitted with SNCR or without any secondary techniques for the reduction of NO_x.

For plants fitted with SCR, no significant difference is observed between the maximum daily average obtained with 'base' and 'fine' data filtering, while for plants fitted with SNCR or with no secondary techniques this difference is generally higher, reflecting the lower intrinsic stability of the process.

The reported data do not show a clear correlation between the achieved emission levels and the type and amount of reagent used or the age and size of the plant. All plants are fluidised bed incinerators.

Ammonia

Ammonia emissions are related to reactant slip from SCR or SNCR. The main technique in use to control such emissions is process optimisation as well as good maintenance of the catalyst in the case of SCR. SCR can also be implemented as slip catalyst to further react the unreacted ammonia after the main reduction has taken place in a SNCR system.

Ammonia emission data from plants incinerating predominantly SS, based on continuous measurements, are shown in Figure 3.41 for 7 reference lines. The corresponding detailed graphs are Figure 8.39 of Annex 8.6 for daily and yearly emission levels, and Figure 8.91 of Annex 8.7 for half-hourly emission levels.

For each emission concentration range represented on the horizontal axis, the pie charts underneath show the shares of reference lines, among those achieving emission levels within the given range, that are fitted with SCR, with SNCR and a downstream wet scrubber, and with SNCR and downstream dry techniques (emissions from plants not operating secondary de-NO_x techniques are not relevant for ammonia slip).

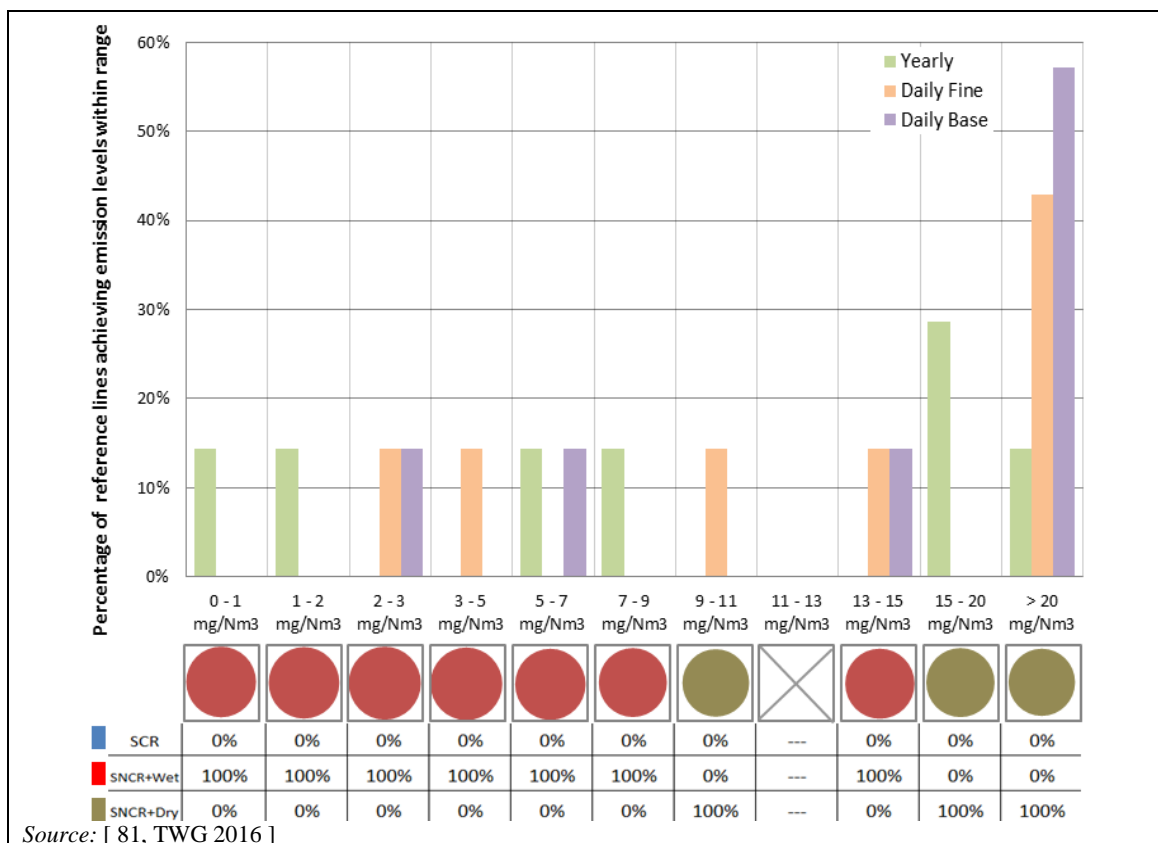

Figure 3.41: Continuously monitored NH₃ emissions to air from reference lines incinerating predominantly SS

With the exception of PL02, which is fitted with SNCR and reports NH₃ emission levels close to 90 mg/Nm³ as a yearly average and 235 mg/Nm³ as a maximum daily average, the emission levels achieved by the plants monitoring ammonia continuously range between close to the limit of quantification and 19 mg/Nm³ as a yearly average and 47 mg/Nm³ as a maximum daily average. Plants fitted with SNCR and a wet scrubber generally achieve emission levels below 13.4 mg/Nm³. None of the plants fitted with SCR monitor ammonia continuously. In addition to PL02, reference lines PL07.1 and PL07.2 are also fitted with SNCR and report elevated NH₃ emission levels (32 mg/Nm³ and 46 mg/Nm³ as a maximum daily average); at the same time, these two reference lines report extremely low NO_x levels (11 mg/Nm³ and 19 mg/Nm³ as a yearly average). Such high NH₃ emission levels are reported to be due not to an excessive ammonia injection rate (ammonia slip) but to the direct ammonia emissions from combusting wet (only mechanically dewatered) sewage sludge at the incineration conditions of these plants. The ammonia load in the air extracted from the sludge dewatering plant and used as combustion air is a further contributor to ammonia emissions.

No significant difference is apparent between the maximum daily averages obtained with the 'base' and 'fine' data filtering modes.

Only two reference lines reported data for periodic monitoring, with reported emission maxima of 0.1 mg/Nm³ (reference line AT08-1 fitted with SCR and a wet scrubber) and 5.7 mg/Nm³ (reference line FR98 fitted with SNCR and DSI).

The data do not show a clear correlation between the achieved emission levels and the type and amount of reagent used or the age and size of the plant. All plants are fluidised bed incinerators.

TVOC

TVOC emission data from 14 reference lines incinerating predominantly SS, based on continuous measurements, are shown in Figure 3.42 in simplified form. The corresponding detailed graphs are Figure 8.40 of Annex 8.6 for daily and yearly emission levels, and Figure 8.92 of Annex 8.7 for half-hourly emission levels.

For each emission concentration range represented on the horizontal axis, the pie charts underneath show the shares of reference lines, among those achieving emission levels within the given range, that fall within different size classes (the thresholds for small, medium and large plants are described in the introductory text of Chapter 3).

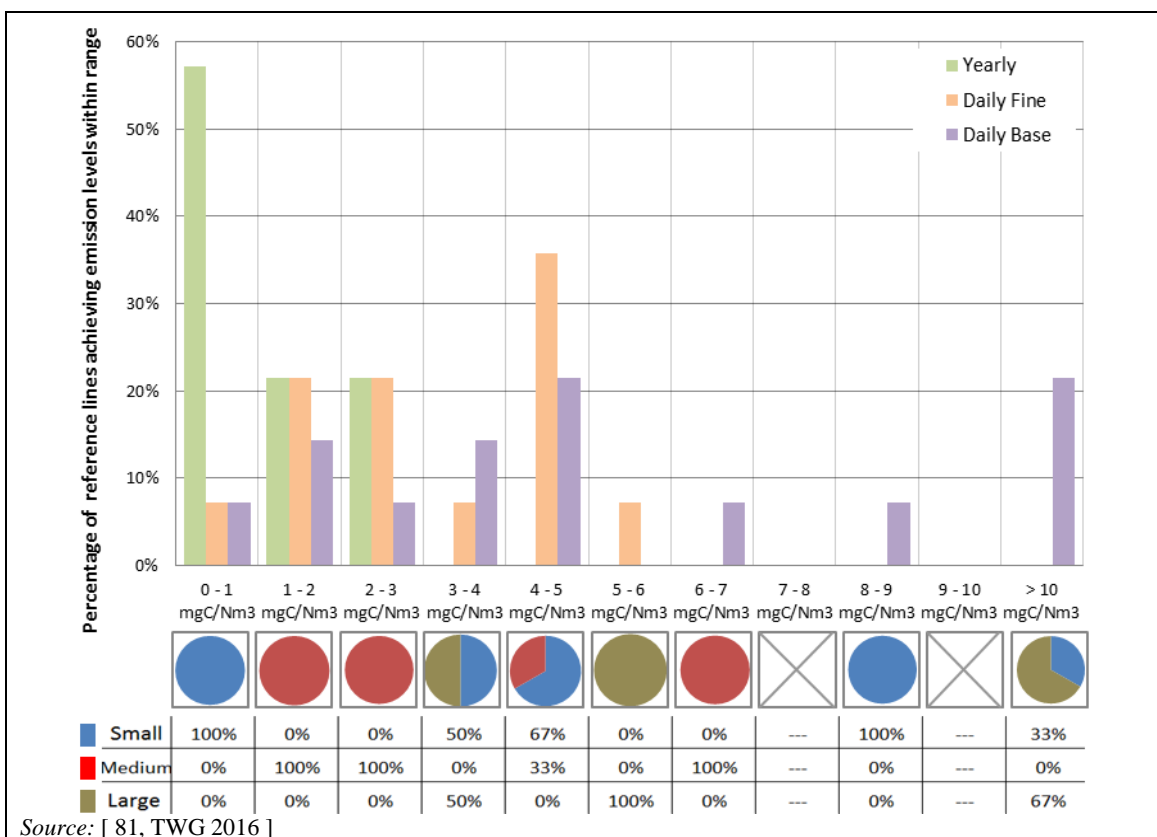

Figure 3.42: Continuously monitored TVOC emissions to air from reference lines incinerating predominantly SS

The emission levels range between close to the limit of quantification and 3 mg/Nm³ as a yearly average and 5.1 mg/Nm³ as a maximum daily average ('fine' data filtering). For three reference lines, the maximum daily average shows higher emission peaks when using the 'base' data filtering, generally related to OTNOC.

The reported data do not show a clear correlation between the achieved emission levels and the technique installed, the type and amount of reagent used or the age and size of the plant. All plants are fluidised bed incinerators.

Carbon monoxide

CO emission data from 17 reference lines incinerating predominantly SS, based on continuous measurements, are shown in Figure 3.43 in simplified form. The corresponding detailed graphs are Figure 8.41 of Annex 8.6 for daily and yearly emission levels, and Figure 8.93 of Annex 8.7 for half-hourly emission levels.

For each emission concentration range represented on the horizontal axis, the pie charts underneath show the shares of reference lines, among those achieving emission levels within the given range, that fall within different size classes (the thresholds for small, medium and large plants are described in the introductory text of Chapter 3).

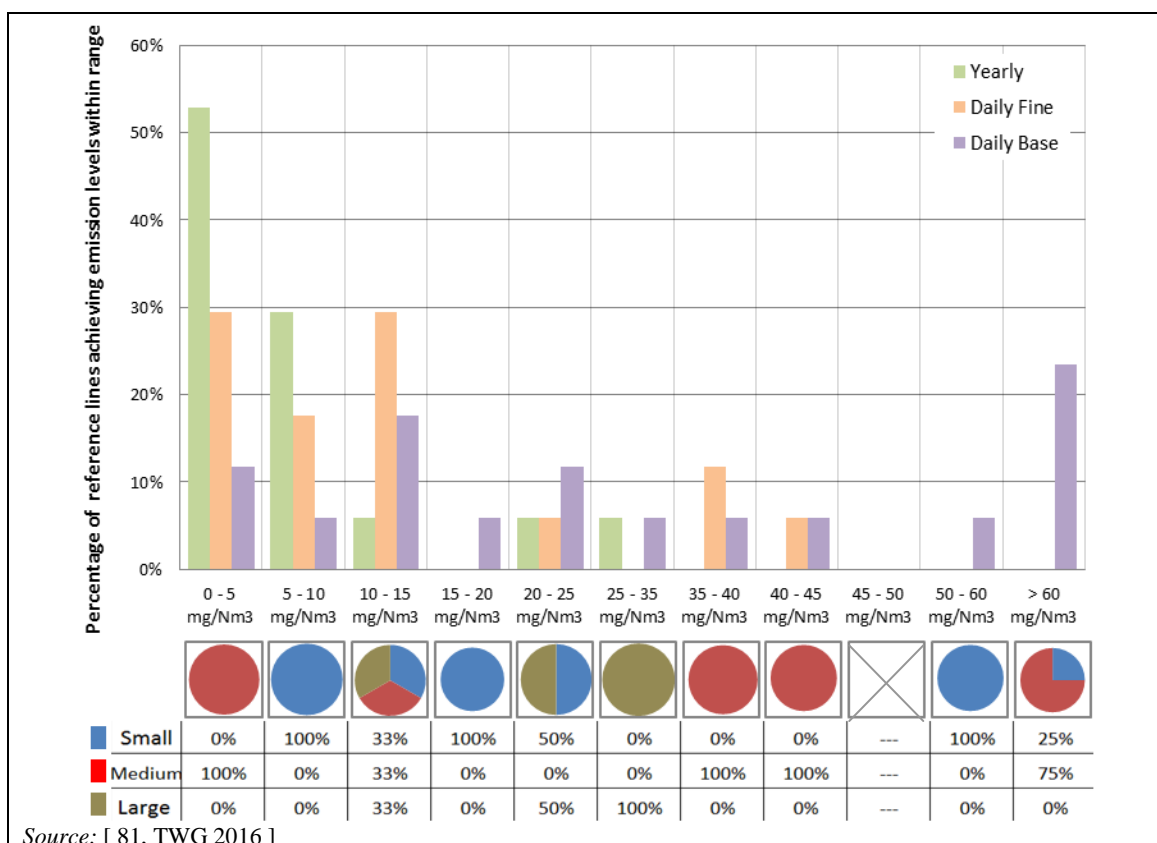

Figure 3.43: Continuously monitored CO emissions to air from reference lines incinerating predominantly SS

The emission levels range between close to the limit of quantification and 29 mg/Nm³ as a yearly average and 42 mg/Nm³ as a maximum daily average ('fine' data filtering). Similar to TVOC emissions, in some cases higher emission peaks are observed in the values obtained under the 'base' data filtering, generally related to OTNOC.

The reported data do not show a clear correlation between the achieved emission levels and the technique installed, the type and amount of reagent used or the age and size of the plant. All plants are fluidised bed incinerators.

PCDD/F, PCBs and PAHs

For reaching low levels of PCDD/F emissions, primary as well as secondary measures are important. In the firing system, effective mixing of the gases (high turbulence) improves the destruction of PCDD/F and similar compounds already present in the waste. Avoiding the temperature window for the recombination of PCDD/F and similar compounds in the boiler and flue-gas treatment system avoids the *de novo* synthesis of new PCDD/F.

For further reduction, three main types of techniques are in use:

1. static or moving-bed activated carbon filter;
2. injection of activated carbon (alone or mixed with other reagents) to be removed in the de-duster;
3. destruction of gaseous PCDD/F on a catalyst, including the case of catalytic filter bags.

The use of activated carbon has the advantage of also reducing mercury emissions. Catalysts are mainly used to reduce NO_x emissions.

PCDD/F emission data from 14 reference lines incinerating predominantly SS, based on periodic measurements, are shown in simplified form in Figure 3.44. The corresponding detailed graph is Figure 8.136 of Annex 8.8.

For each emission concentration range represented on the horizontal axis, the pie charts underneath show the shares of reference lines, among those achieving emission levels within the given range, that are fitted with a fixed adsorption bed, without a fixed adsorption bed and a wet scrubber, and without a fixed adsorption bed and dry FGC techniques.

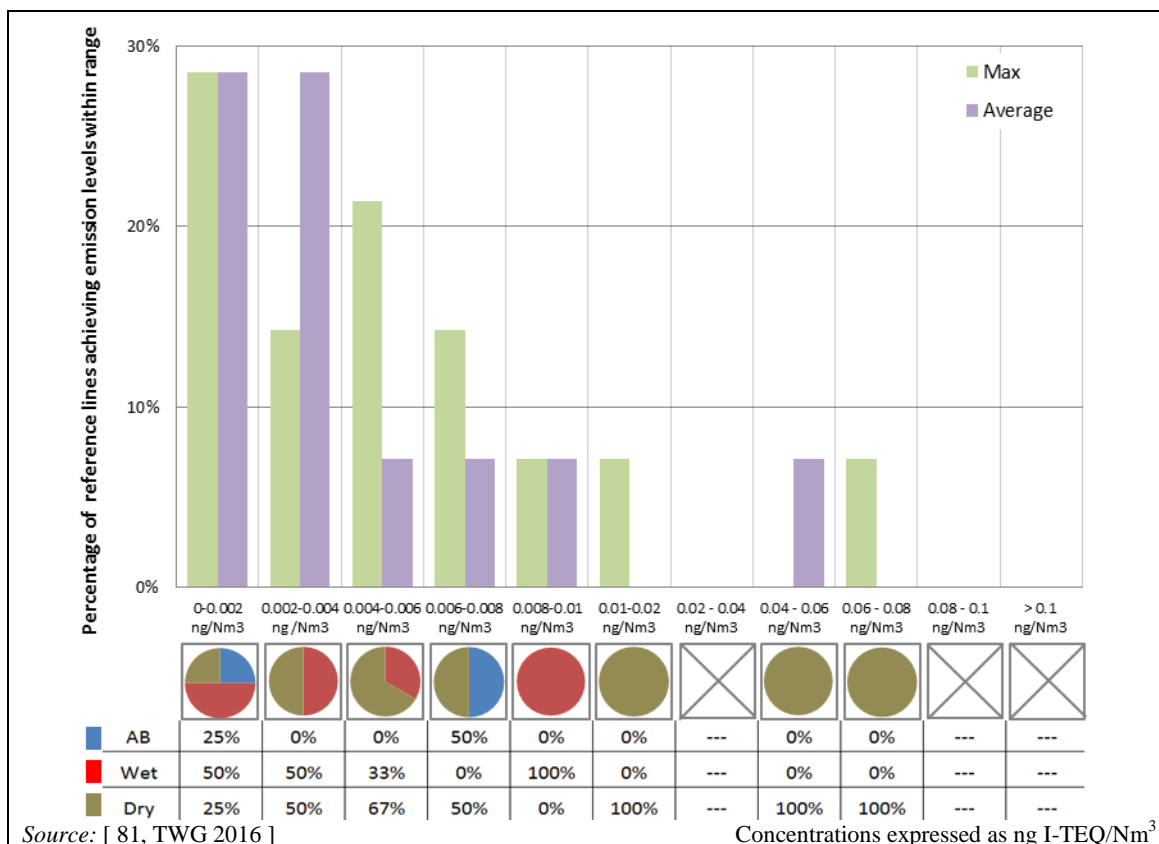

Figure 3.44: Periodically monitored PCDD/F emissions to air from reference lines incinerating predominantly SS

The emission levels range between close to the limit of quantification and $0.011 \text{ ng I-TEQ/Nm}^3$, except for one reference line showing a level of $0.06 \text{ ng I-TEQ/Nm}^3$.

The reported data do not show a clear correlation between the achieved emission levels and the type and amount of reagent used or the age and size of the plant. All plants are fluidised bed incinerators.

Polychlorinated biphenyls (PCBs) and polyaromatic hydrocarbons (PAHs) are removed by the same techniques as PCDD/F, meaning that an effective flue-gas cleaning system for PCDD/F will also deal with PCBs and PAHs.

Among the reference lines incinerating predominantly SS, the following reported emission levels, based on periodic measurements, for dioxin-like PCBs, for PAHs and for BaP:

- Two reference lines (UK15 and FR98) for dioxin-like PCBs. The maximum value reported is below 0.001 ng WHO-TEF .
- Three reference lines (DE15-1, DE15-2 and UK15) for PAHs. They are all fluidised bed incinerators fitted with ESP, wet scrubber and bag filter, and all report the injection of activated carbon. DE15-1 is a recently retrofitted medium-sized plant and reports an emission level of 0.002 g/Nm^3 . UK15 is an older small plant and reports an emission level of 13 g/Nm^3 .
- One reference line for BaP emissions (DE16, a fluidised bed incinerator fitted with ESP, wet scrubber, bag filter and using activated carbon injection) reports a level of 0.1 g/Nm^3 .

Mercury

The vast majority of plants use activated carbon, either as a fixed-bed system or in an entrained flow activated carbon injection system. The consumption rate as well as the quality of activated carbon (e.g. brominated or sulphur-impregnated) directly affect the emission levels. Other less frequently used techniques are the use of zeolites or the capture of mercury in the acidic wet scrubber, which can serve as a sink for mercury if it is present in the Hg(II) chloride form. The mercury that has been transferred from the gas stream to the scrubber liquor can then be removed by a waste water treatment plant.

If mercury is present in metallic form, the use of oxidation agents is needed, such as brominated activated carbon injection or boiler bromine addition (see mercury removal techniques). [74, TWG 2004]

Under certain conditions (e.g. high input rate of mercury), the removal capacity limits of the FGC systems may be exceeded, leading to temporarily elevated mercury emissions. This may be reflected by cases where the performance levels of a reference line for different averaging periods show large variations.

Mercury emission data are based either on continuous or periodic measurement and are shown in the following figures, in simplified form within this chapter and in detail in Annex 8.6 and Annex 8.8; half-hourly emission levels are shown Annex 8.7:

- Figure 3.45, for the emission levels of 14 reference lines incinerating predominantly SS and monitoring Hg periodically. The corresponding detailed graph is Figure 8.137.
- Figure 3.46, for the daily and yearly emission levels of 5 reference lines incinerating predominantly SS and monitoring Hg continuously. The corresponding detailed graph is Figure 8.42.

- Figure 3.47, for the half-hourly emission levels of 5 reference lines incinerating predominantly SS and monitoring Hg continuously. The corresponding detailed graph is Figure 8.94.
- Figure 3.48, for the monthly emission levels of 5 reference lines incinerating predominantly SS and monitoring Hg continuously. The corresponding detailed graph is Figure 8.95.

For each emission concentration range represented on the horizontal axis, the pie charts underneath show the shares of reference lines, among those achieving emission levels within the given range, that are fitted with a fixed adsorption bed, without a fixed adsorption bed and a wet scrubber, and without a fixed adsorption bed and dry FGC techniques.

The monthly levels presented in Figure 3.48 are derived based on continuous monitoring data and provide an indication of the emission levels achieved when measuring mercury with an averaging period typical of long-term sampling methods. For monthly levels, which are hardly affected by short-term peaks, only the 'base' filtering mode is presented.

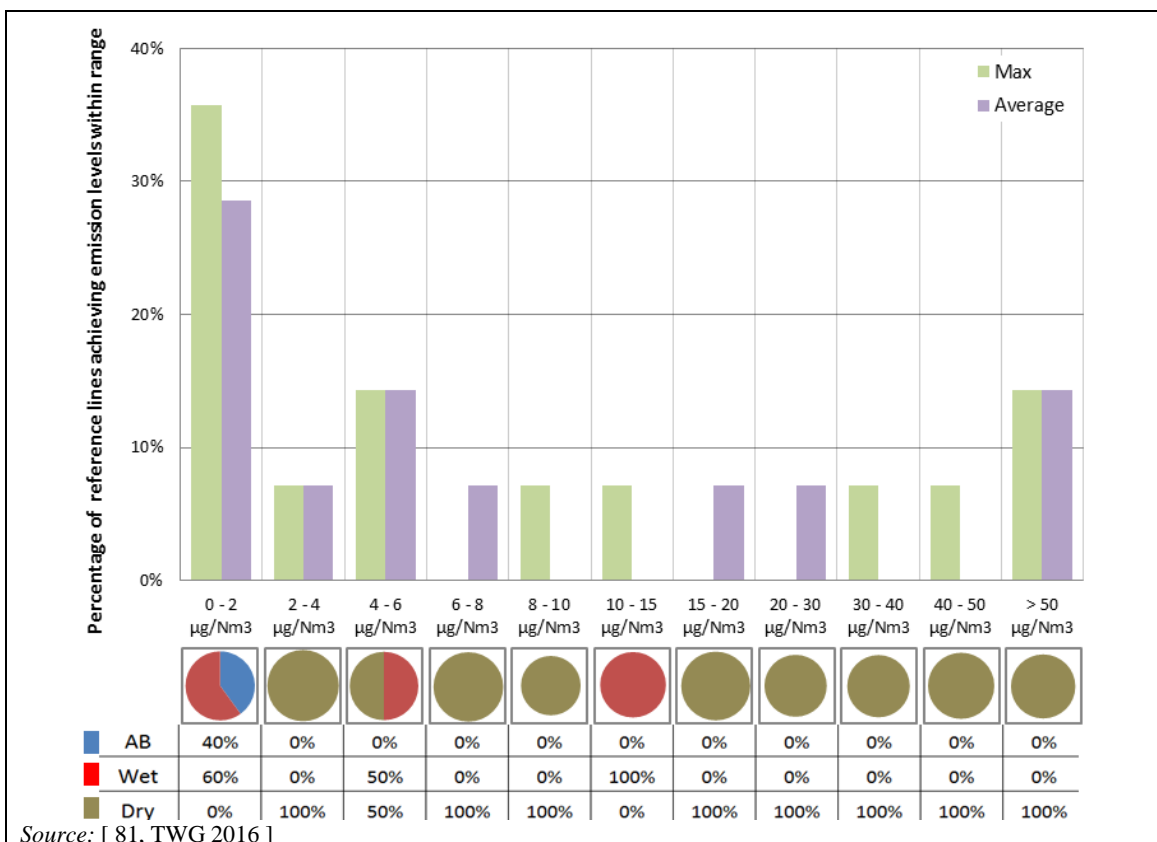

Figure 3.45: Periodically monitored mercury emissions to air from reference lines incinerating predominantly SS

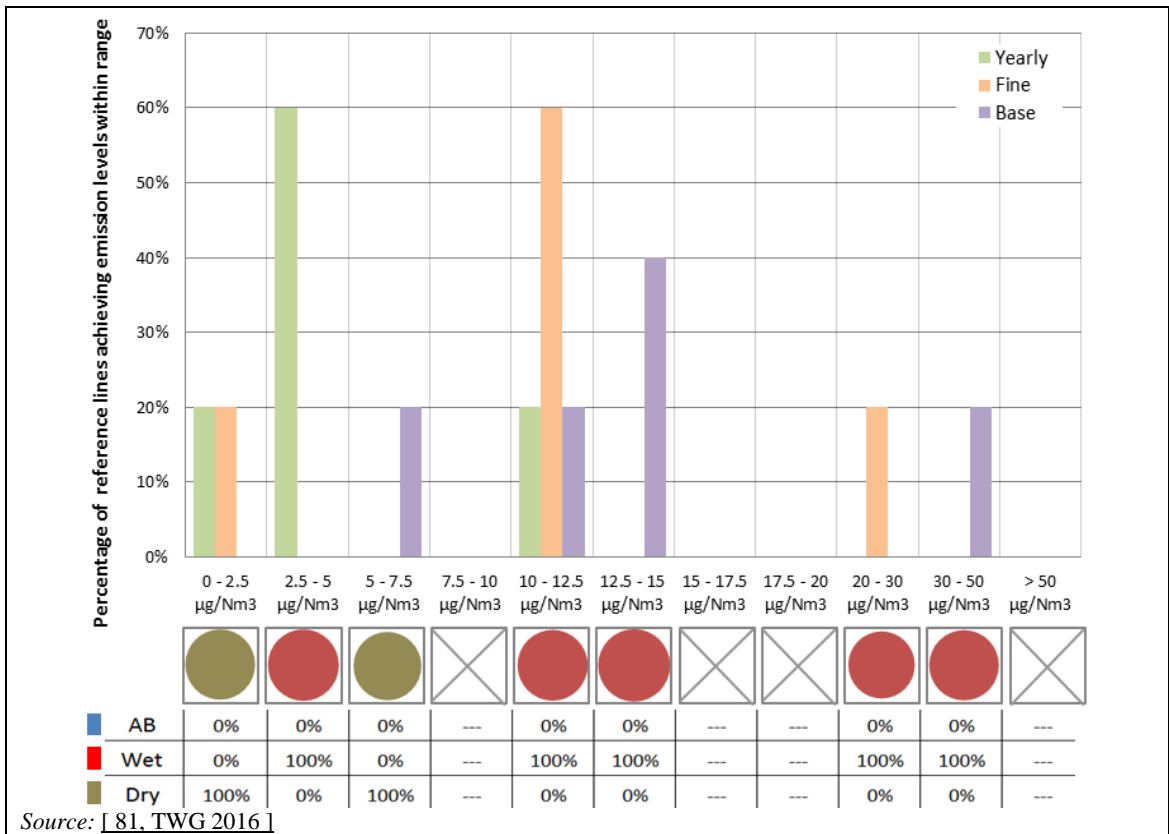

Figure 3.46: Continuously monitored mercury emissions to air from reference lines incinerating predominantly SS: daily and yearly emission levels

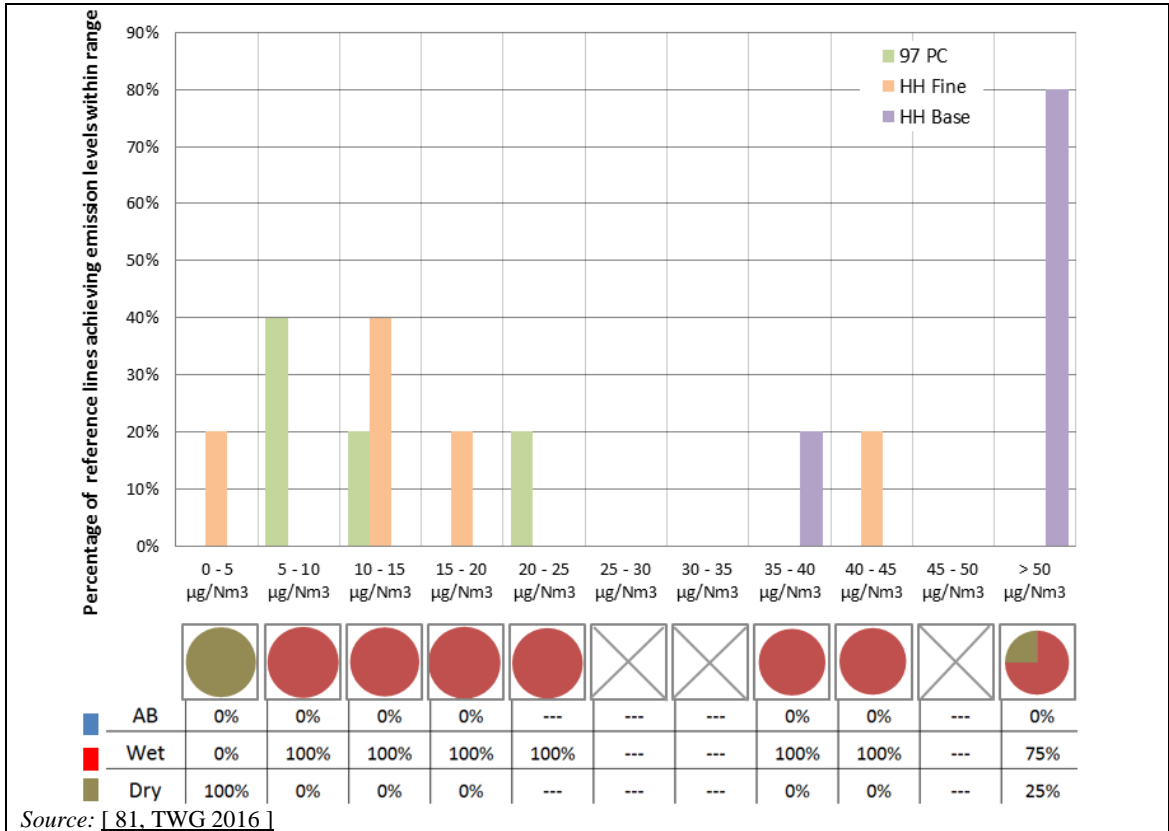

Figure 3.47: Continuously monitored mercury emissions to air from reference lines incinerating predominantly SS: half-hourly emission levels

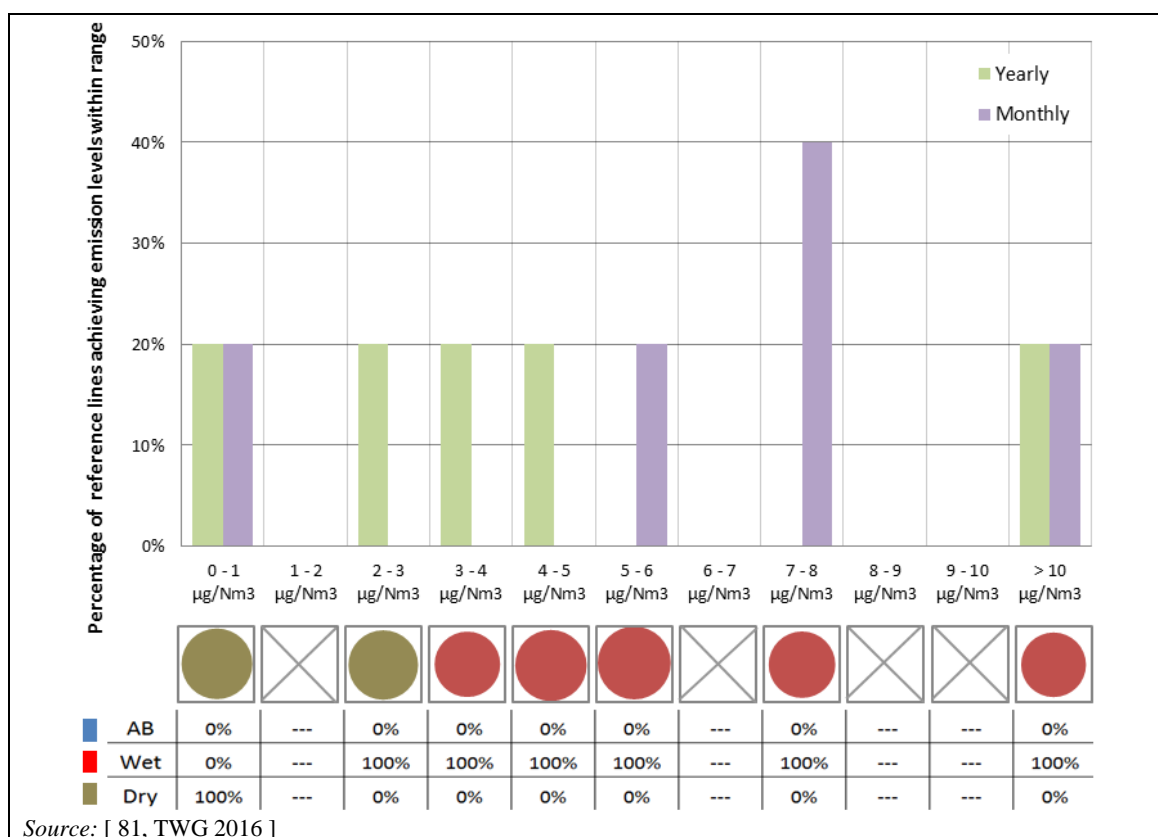

Figure 3.48: Continuously monitored mercury emissions to air from reference lines incinerating predominantly SS: monthly emission levels

The emission levels range between close to the limit of quantification and 0.01 mg/Nm^3 as a yearly and monthly average, and 0.024 mg/Nm^3 as a maximum daily average ('fine' data filtering). In certain cases the maximum daily average obtained with 'base' data filtering may be substantially higher (up to 0.036 mg/Nm^3), which may reflect not only high mercury input episodes, but also OTNOC situations where the daily average typically includes only a few half-hourly periods and where the mercury levels measured are elevated.

Plants that measure mercury periodically report averages over the sampling period generally below 0.01 mg/Nm^3 , with four exceptions (PL02, PL05, PL07-2 and PL07-1) that reported values between 0.04 mg/Nm^3 and 0.13 mg/Nm^3 .

The reported data do not show a clear correlation between the achieved emission levels and the type and amount of reagent used or the age and size of the plant. All plants are fluidised bed incinerators.

Antimony, arsenic, chromium, cobalt, copper, lead, manganese, nickel and vanadium

The techniques used to remove dust reduce the emissions of dust-bound metals.

[Sb+As+Cr+Co+Cu+Pb+Mn+Ni+V] emission data, based on periodic measurements, are shown in simplified form in Figure 3.49, for 17 reference lines incinerating predominantly SS. The corresponding detailed graph is Figure 8.138 of Annex 8.8.

For each emission concentration range represented on the horizontal axis, the pie charts underneath show the shares of reference lines, among those achieving emission levels within the given range, that are fitted with a bag filter and with other techniques (such as ESPs).

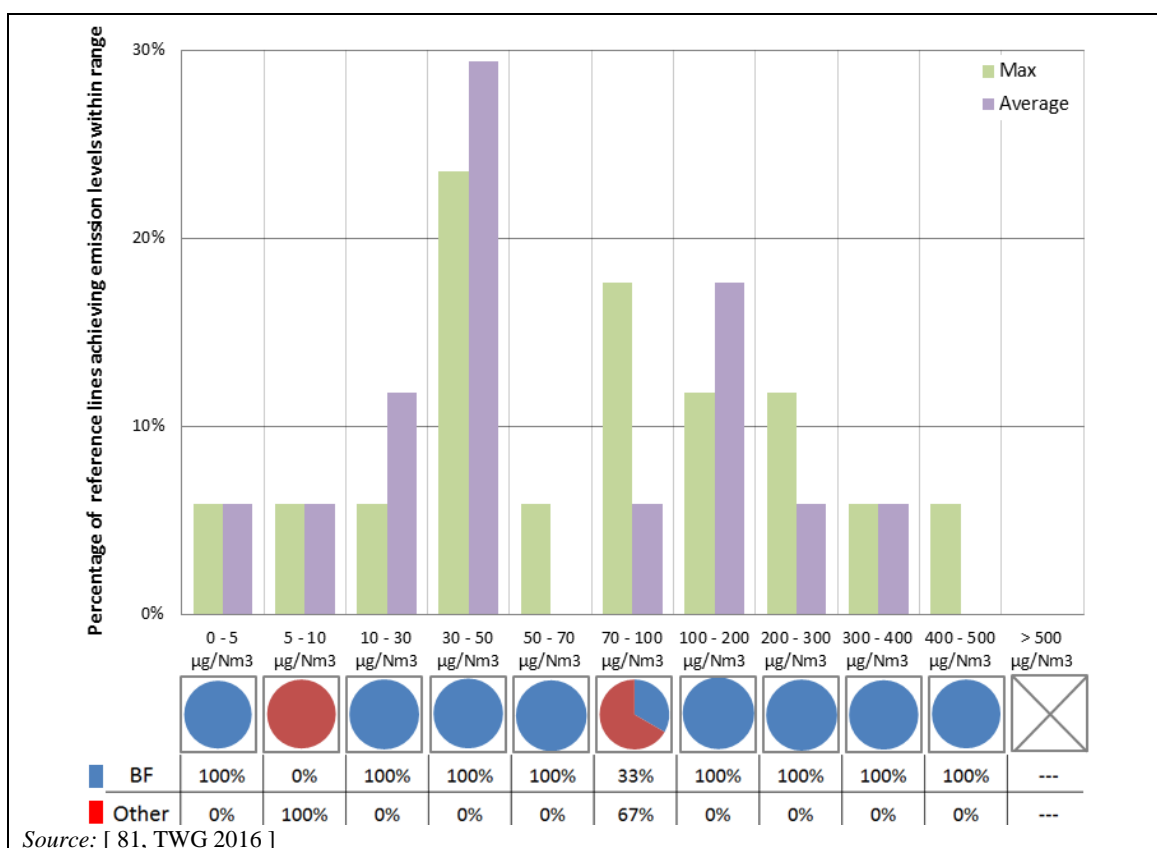

Figure 3.49: Periodically monitored Sb+As+Cr+Co+Cu+Pb+Mn+Ni+V emissions to air from reference lines incinerating predominantly SS

The emission levels range between close to the limit of quantification and 0.3 mg/Nm^3 , with the exception of one reference line showing a level of 0.5 mg/Nm^3 , as a maximum of the averages over the sampling period.

The reported data do not show a clear correlation between the achieved emission levels and the technique installed or the age and size of the plant. All plants are fluidised bed incinerators.

Cadmium and thallium

The techniques used to remove dust also reduce the emissions of dust-bound metals.

[Cd+Tl] emission data, based on periodic measurements, are shown in simplified form in Figure 3.50, for 13 reference lines incinerating predominantly SS. The corresponding detailed graph is Figure 8.139 of Annex 8.8.

For each emission concentration range represented on the horizontal axis, the pie charts underneath show the shares of reference lines, among those achieving emission levels within the given range, that are fitted with a bag filter and with other techniques (such as ESPs).

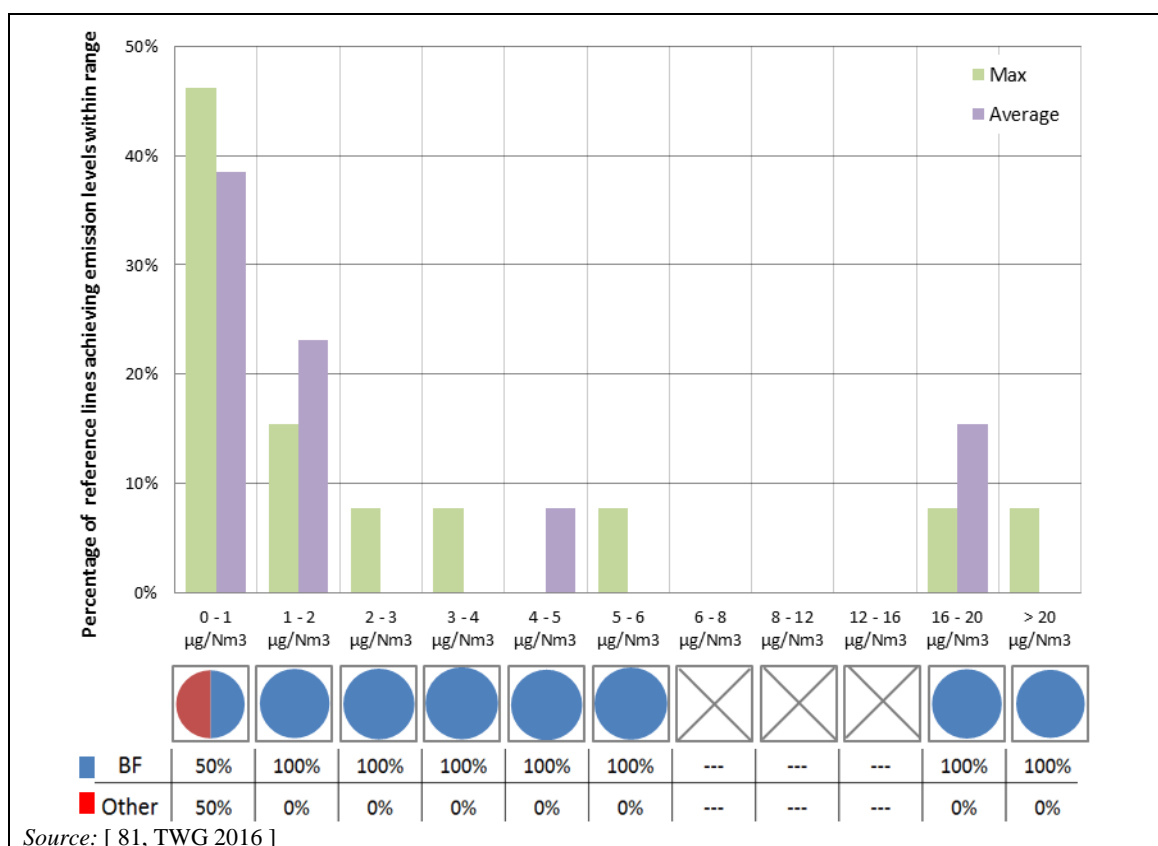

Figure 3.50: Periodically monitored Cd+Tl emissions to air from reference lines incinerating predominantly SS

The emission levels are almost always very low and range between close to the limit of quantification and 0.005 mg/Nm^3 , with the exception of two reference lines (NL06 and PL05) showing levels of 0.02 mg/Nm^3 and 0.036 mg/Nm^3 respectively, as a maximum of the averages over the sampling period.

The reported data do not show a clear correlation between the achieved emission levels and the technique installed or the age and size of the plant. All plants are fluidised bed incinerators.

3.2.2.3 Emissions to air from the incineration of hazardous waste

Hydrogen chloride and hydrogen fluoride

With few exceptions, the plants that participated in the 2016 data collection that predominantly incinerate hazardous waste are rotary kilns fitted with wet abatement systems. The exceptions are mostly liquid waste furnaces incinerating residues from the chemical sector and grate incinerators fitted with dry or semi-wet systems, such as DE31, DE32 and DE33, which incinerate contaminated waste wood.

HCl emission data from 33 reference lines incinerating predominantly HW, based on continuous measurements, are shown in Figure 3.51 in simplified form. The corresponding detailed graphs are Figure 8.43 of Annex 8.6 for daily and yearly emission levels, and Figure 8.96 of Annex 8.7 for half-hourly emission levels.

For each emission concentration range represented on the horizontal axis, the pie charts underneath show the shares of reference lines, among those achieving emission levels within the given range, that are fitted with a wet scrubber and with other techniques (such as semi-wet absorbers or DSI).

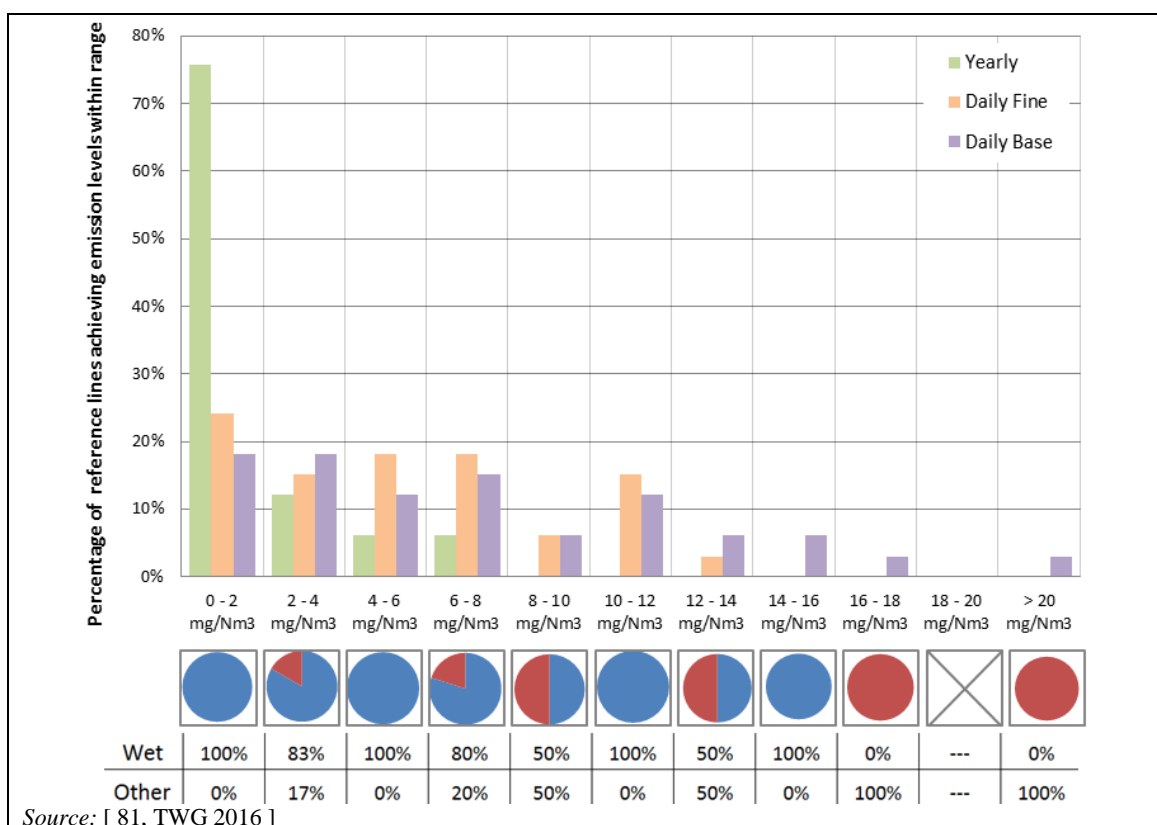

Figure 3.51: Continuously monitored HCl emissions to air from reference lines incinerating predominantly HW

The emission levels range between close to the limit of quantification and 7.5 mg/Nm^3 as a yearly average and 12 mg/Nm^3 as a maximum of the daily average ('fine' data filtering). In most cases the maximum daily average obtained with 'base' data filtering does not substantially change from the value obtained with 'fine' data filtering; some exceptions where these values diverge are related to unreported maintenance periods (e.g. BE09.1 and BE09.3).

The reported data do not show a clear correlation between the achieved emission levels and the type and amount of reagent used or the age and size of the plant. Most plants are rotary kilns.

Hydrogen fluoride (HF) emission data, based either on continuous or periodic measurements, are shown in the following figures, in simplified form within this chapter and in detail in Annex 8.6 and Annex 8.8; half-hourly emission levels are shown Annex 8.7:

- Figure 3.52, for 32 reference lines incinerating predominantly HW and monitoring HF periodically. The corresponding detailed graph is Figure 8.140.
- Figure 3.53, for 9 reference lines incinerating predominantly HW and monitoring HF continuously. The corresponding detailed graphs are Figure 8.44 for daily and yearly emission levels, and Figure 8.97 for half-hourly emission levels.

For each emission concentration range represented on the horizontal axis, the pie charts underneath show the shares of reference lines, among those achieving emission levels within the given range, that are fitted with a wet scrubber and with other techniques (such as semi-wet absorbers or DSI).

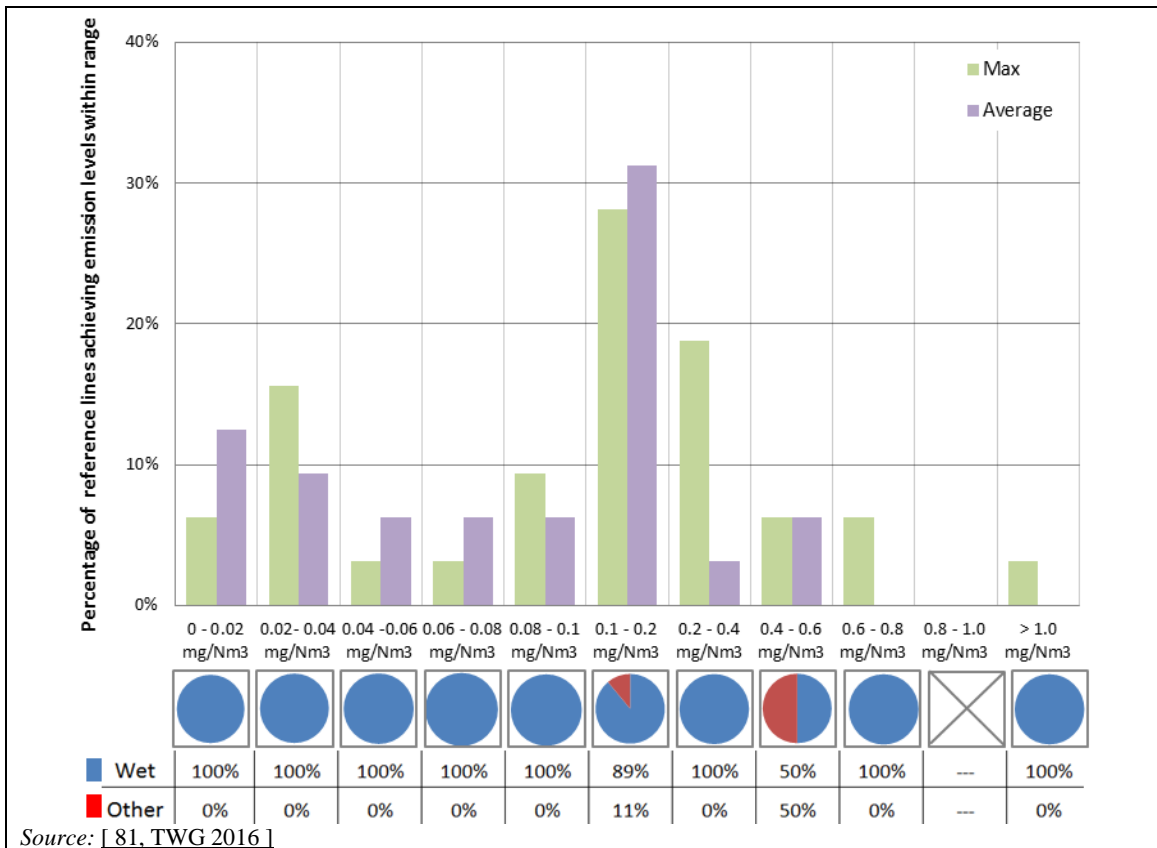

Figure 3.52: Periodically monitored HF emissions to air from reference lines incinerating predominantly HW

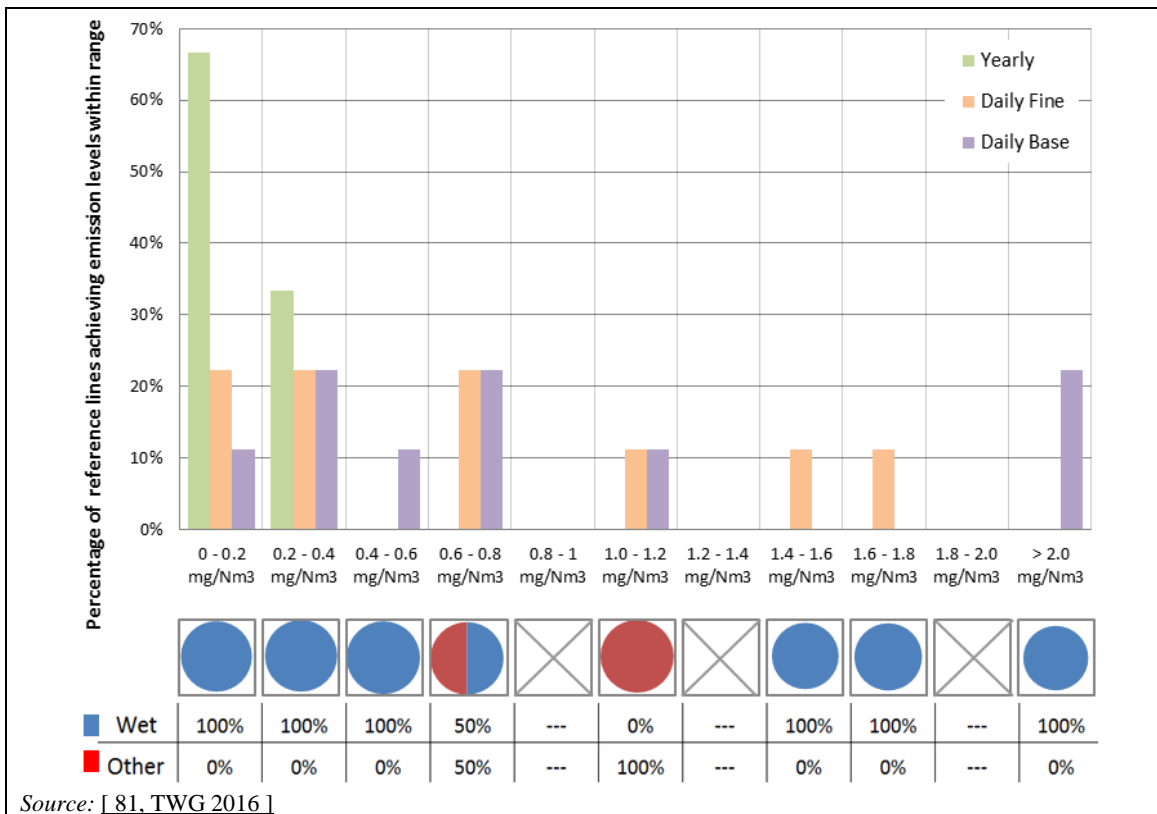

Figure 3.53: Continuously monitored HF emissions to air from reference lines incinerating predominantly HW

The emission levels range between close to the limit of quantification and 0.35 mg/Nm^3 as a yearly average and 1.6 mg/Nm^3 as a maximum daily average; all but one plant measuring HF periodically report maximum levels below 0.66 mg/Nm^3 as an average over the sampling period. The maximum daily average obtained with 'base' data filtering does not substantially vary from the value obtained with 'fine' data filtering.

The reported data do not show a clear correlation between the achieved emission levels and the type and amount of reagent used or the age and size of the plant.

Sulphur dioxide

The types of flue-gas cleaning systems in use are the same as those for HCl, with the main difference that wet scrubbers are operated at a slightly basic pH (usually 7–8).

SO₂ emission data from 34 reference lines incinerating predominantly HW, based on continuous measurements, are shown in Figure 3.54 in simplified form. The corresponding detailed graphs are Figure 8.45 of Annex 8.6 for daily and yearly emission levels, and Figure 8.98 of Annex 8.7 for half-hourly emission levels.

For each emission concentration range represented on the horizontal axis, the pie charts underneath show the shares of reference lines, among those achieving emission levels within the given range, that are fitted with a wet scrubber and with other techniques (such as semi-wet absorbers or DSI).

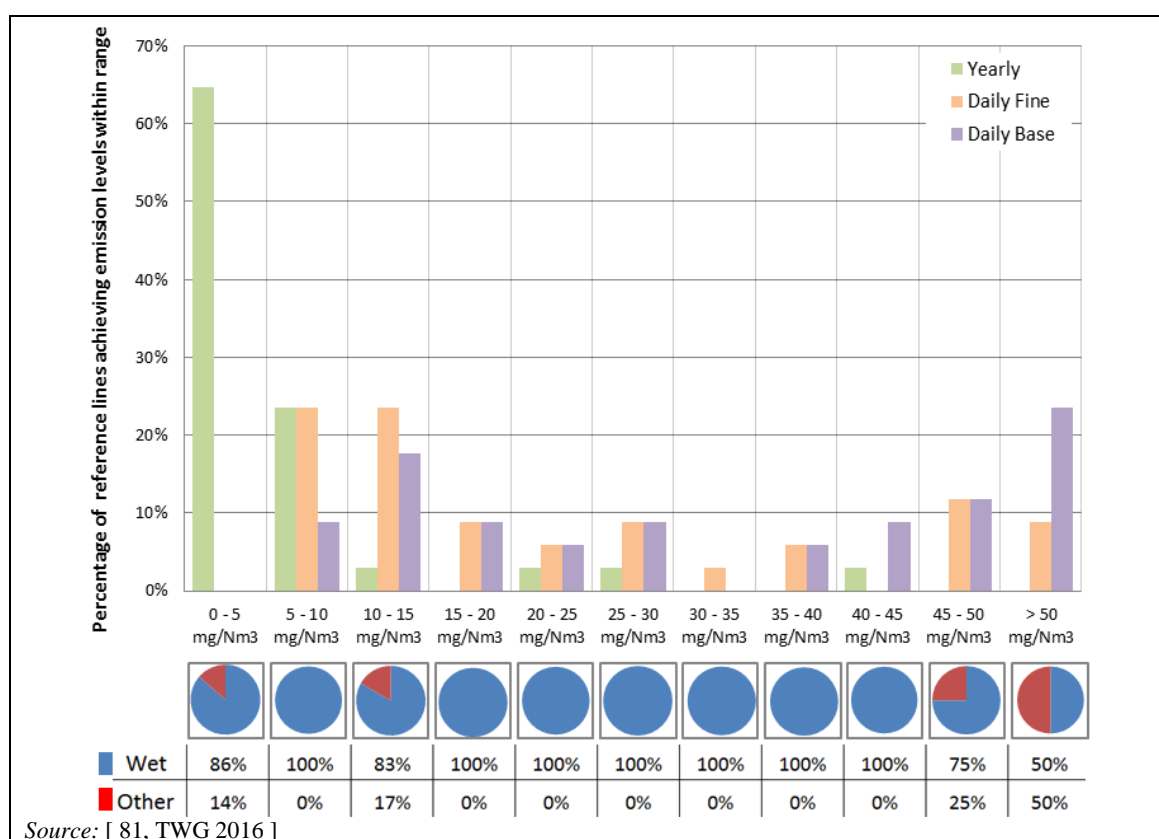

Figure 3.54: Continuously monitored SO₂ emissions to air from reference lines incinerating predominantly HW

The emission levels range between close to the limit of quantification and 43 mg/Nm^3 as a yearly average and between 5 mg/Nm^3 and 78 mg/Nm^3 as a maximum daily average. The graph shows that the vast majority of plants fitted with wet abatement techniques generally achieve emission levels below 40 mg/Nm^3 as a maximum daily average ('fine' data filtering).

The reported data do not show a clear correlation between the achieved emission levels and the type and amount of reagent used or the age and size of the plant. Most plants are rotary kilns.

Dust

Compared to other types of incinerators, hazardous waste incineration plants that participated in the 2016 data collection are seldom fitted with a bag filter (BF) and mostly use an ESP for the reduction of dust emissions, with the wet scrubber acting as a further polishing dedusting stage and in some cases a (multi-)cyclone for pre-dedusting. The use of a fixed adsorption bed, which on the one hand may provide further dust reduction and on the other is associated with substantial pressure drop, is also relatively frequent in hazardous waste incinerators.

Dust emission data from 38 reference lines incinerating predominantly HW, based on continuous measurements, are shown in Figure 3.55 in simplified form. The corresponding detailed graphs are Figure 8.46 of Annex 8.6 for daily and yearly emission levels, and Figure 8.99 of Annex 8.7 for half-hourly emission levels.

For each emission concentration range represented on the horizontal axis, the pie charts underneath show the shares of reference lines, among those achieving emission levels within the given range, that are fitted with a bag filter and with other techniques (such as ESPs).

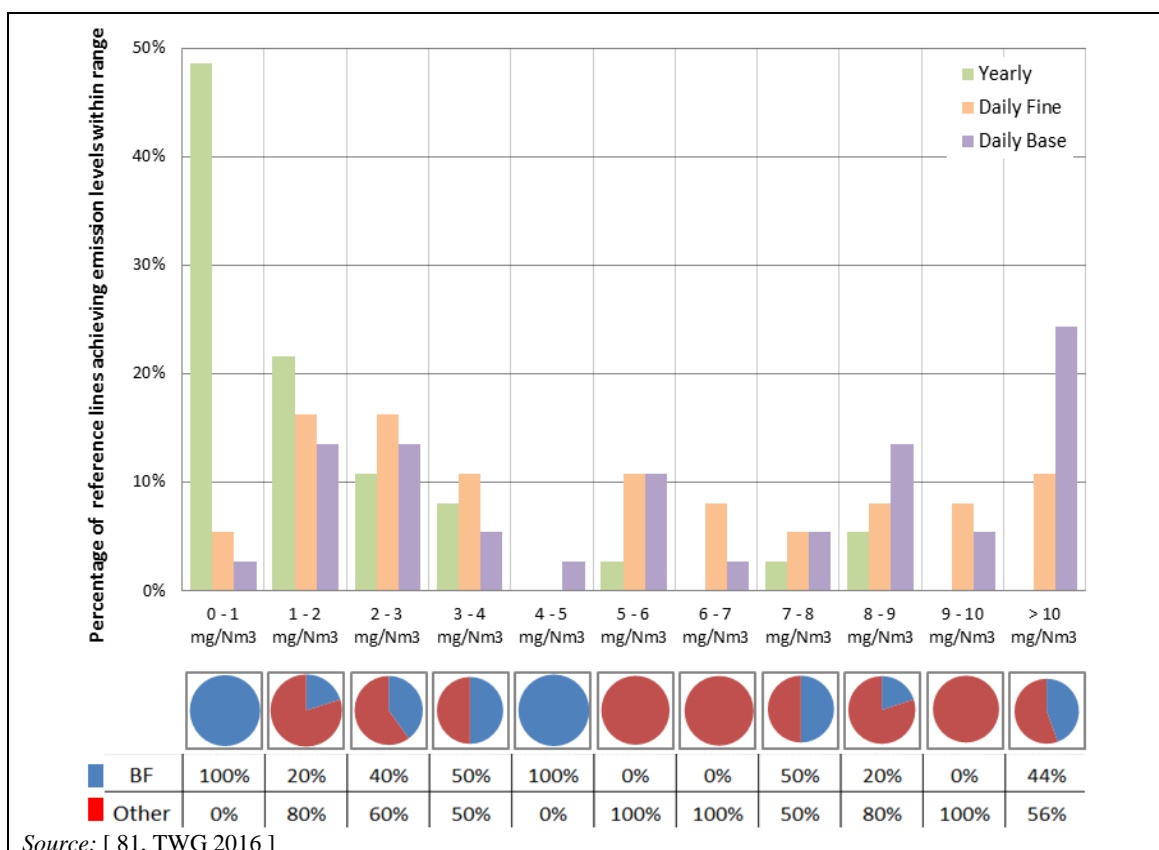

Figure 3.55: Continuously monitored dust emissions to air from reference lines incinerating predominantly HW

The emission levels range between close to the limit of quantification and 8.6 mg/Nm³ as a yearly average and 14.6 mg/Nm³ as a maximum daily average ('fine' data filtering). In some cases the maximum daily average obtained with 'base' data filtering may be substantially higher, generally related to OTNOC situations.

Of the four plants reporting yearly average emission concentrations above 3.2 mg/Nm^3 , only DE32R is fitted with a bag filter. The dust emission pattern reported by this plant indicates probable deterioration of the filter bags.

The reported data do not show a clear correlation between the achieved emission levels and the type and amount of reagents used or the age and size of the plant. Most plants are rotary kilns.

Nitrogen oxides

Around a third of the hazardous waste incinerators that participated in the 2016 data collection report no or only primary techniques for the reduction of NO_x emissions, another third use SNCR and the remaining third SCR.

NO_x emission data from 38 reference lines incinerating predominantly HW, based on continuous measurements, are shown in Figure 3.56 in simplified form. The corresponding detailed graphs are Figure 8.47 of Annex 8.6 for daily and yearly emission levels, and Figure 8.100 of Annex 8.7 for half-hourly emission levels.

For each emission concentration range represented on the horizontal axis, the pie charts underneath show the shares of reference lines, among those achieving emission levels within the given range, that are fitted with SCR, with SNCR but no SCR, and with primary techniques at most.

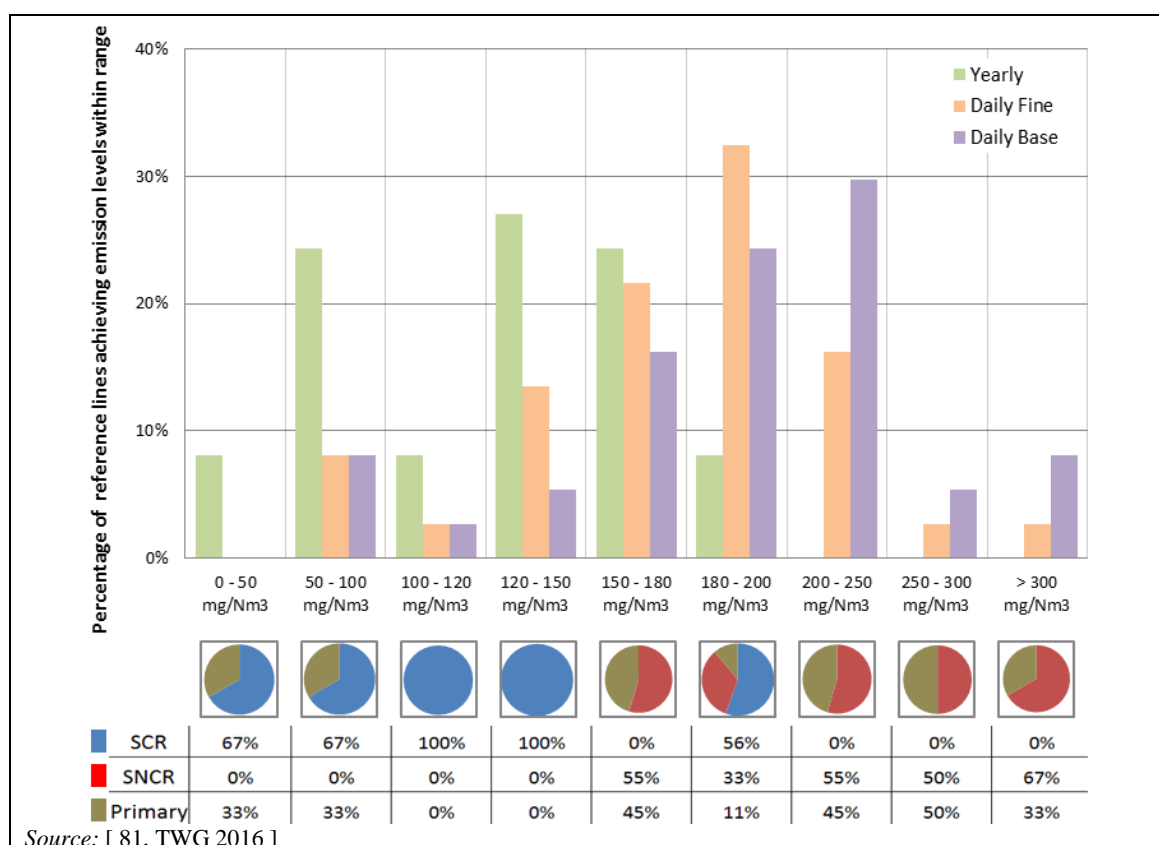

Figure 3.56: Continuously monitored NO_x emissions to air from reference lines incinerating predominantly HW

The emission levels range between 26 mg/Nm^3 and 197 mg/Nm^3 as a yearly average and between 68 mg/Nm^3 and 329 mg/Nm^3 as a maximum daily average ('fine' data filtering). Values significantly above 200 mg/Nm^3 are only observed in plants fitted with SNCR or without secondary techniques for the reduction of NO_x , Plant FR109 being fitted with SNCR but without reporting the use of reagent (neither ammonia nor urea).

For plants fitted with SCR, no significant difference is observed between the maximum daily average obtained with 'base' and 'fine' data filtering, while for plants fitted with SNCR or with no secondary techniques this difference is generally higher, reflecting the lower intrinsic stability of the process.

The reported data do not show a clear correlation between the achieved emission levels and the type and amount of reagent used or the age and size of the plant. Most plants are rotary kilns.

Ammonia

Ammonia emissions are related to reactant slip from SCR or SNCR. The main technique in use to control such emissions is process optimisation as well as good maintenance of the catalyst in the case of SCR. For SNCR, an efficient removal of ammonia can be achieved by a wet scrubber operated at low pH. SCR can also be implemented as slip catalyst to further react the unreacted ammonia after the main reduction has taken place in a SNCR system.

NH₃ emission data, based either on continuous or periodic measurements, are shown in the following figures, in simplified form within this chapter and in detail in Annex 8.6 and Annex 8.8; half-hourly emission levels are shown Annex 8.7:

- Figure 3.57, for 14 reference lines incinerating predominantly HW and monitoring NH₃ periodically. The corresponding detailed graph is Figure 8.141. Figure 3.58, for 7 reference lines incinerating predominantly HW and monitoring NH₃ continuously. The corresponding detailed graphs are Figure 8.48 for daily and yearly emission levels, and Figure 8.101 for half-hourly emission levels.

For each emission concentration range represented on the horizontal axis, the pie charts underneath show the shares of reference lines, among those achieving emission levels within the given range, that are fitted with SCR, with SNCR and a downstream wet scrubber, and with SNCR and downstream dry techniques (emissions from plants not operating secondary de-NO_x techniques are not relevant for ammonia slip).

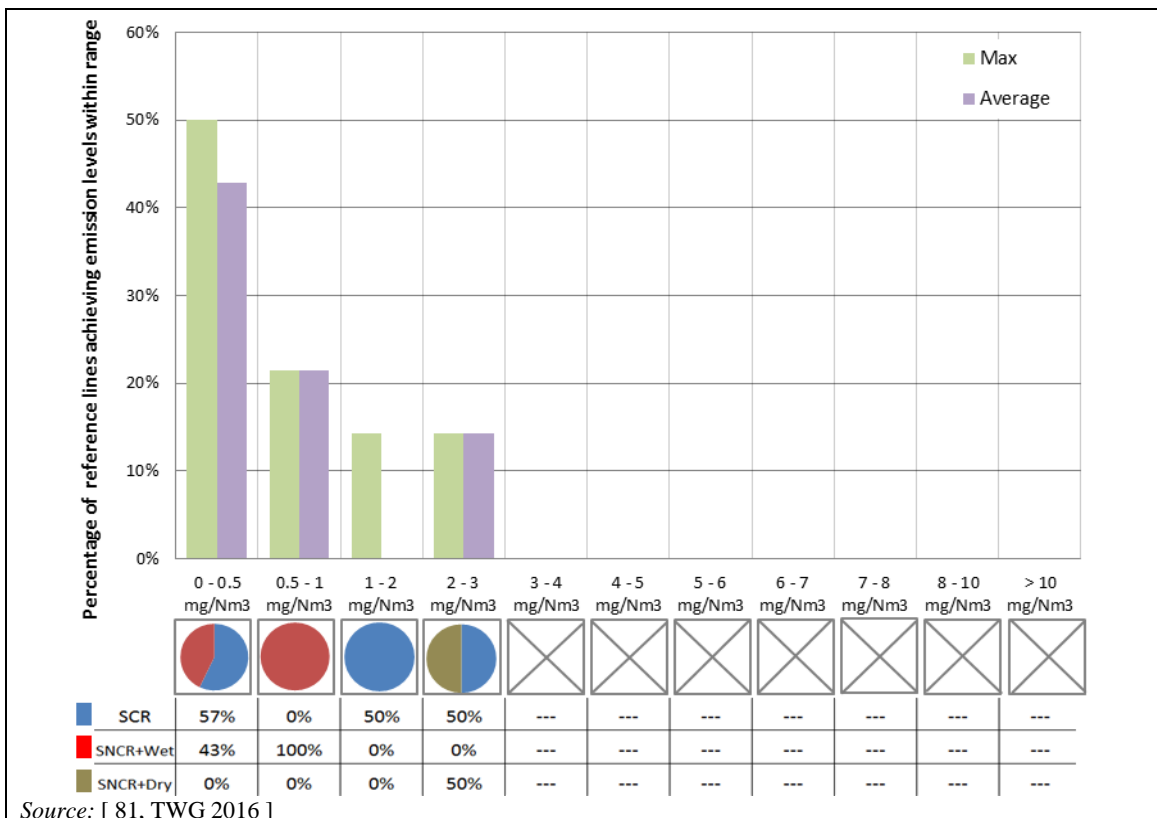

Figure 3.57: Periodically monitored NH₃ emissions to air from reference lines incinerating predominantly HW

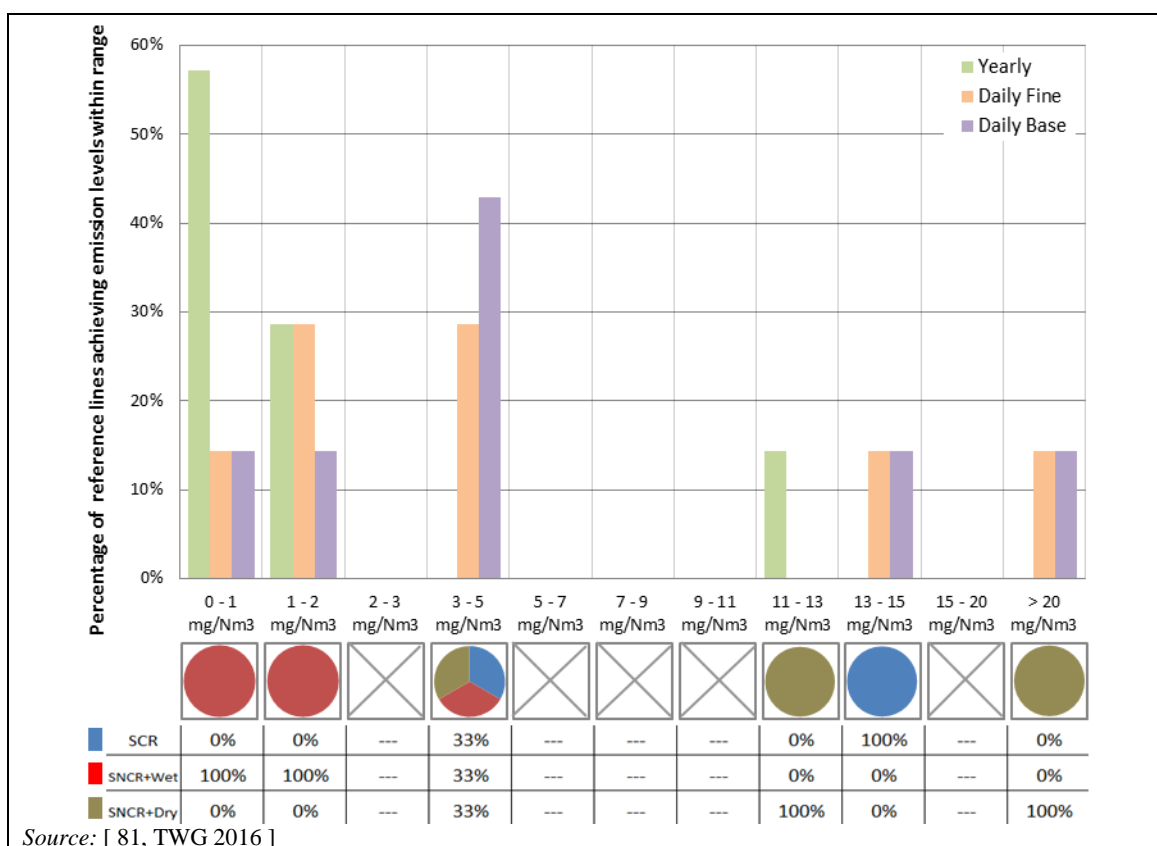

Figure 3.58: Continuously monitored NH₃ emissions to air from reference lines incinerating predominantly HW

With the exception of DE32R, which is fitted with SNCR without a downstream wet abatement system and which reports NH₃ emission levels close to 12 mg/Nm³ as a yearly average and 78 mg/Nm³ as a maximum daily average, the emission levels achieved by the plants monitoring ammonia continuously range between 0.3 mg/Nm³ and 1.8 mg/Nm³ as a yearly average and between 1 mg/Nm³ and 13 mg/Nm³ as a maximum daily average.

All but one of the plants reporting data for periodic monitoring are fitted with a downstream wet abatement system, and all report emissions below 2.3 mg/Nm³.

The data do not show a clear correlation between the achieved emission levels and the type and amount of reagent used or the age and size of the plant. Most plants are rotary kilns.

TVOC

TVOC emission data from 37 reference lines incinerating predominantly HW, based on continuous measurements, are shown in Figure 3.59 in simplified form. The corresponding detailed graphs are Figure 8.49 of Annex 8.6 for daily and yearly emission levels, and Figure 8.102 of Annex 8.7 for half-hourly emission levels.

For each emission concentration range represented on the horizontal axis, the pie charts underneath show the shares of reference lines, among those achieving emission levels within the given range, that fall within different size classes (the thresholds for small, medium and large plants are described in the introductory text of Chapter 3).

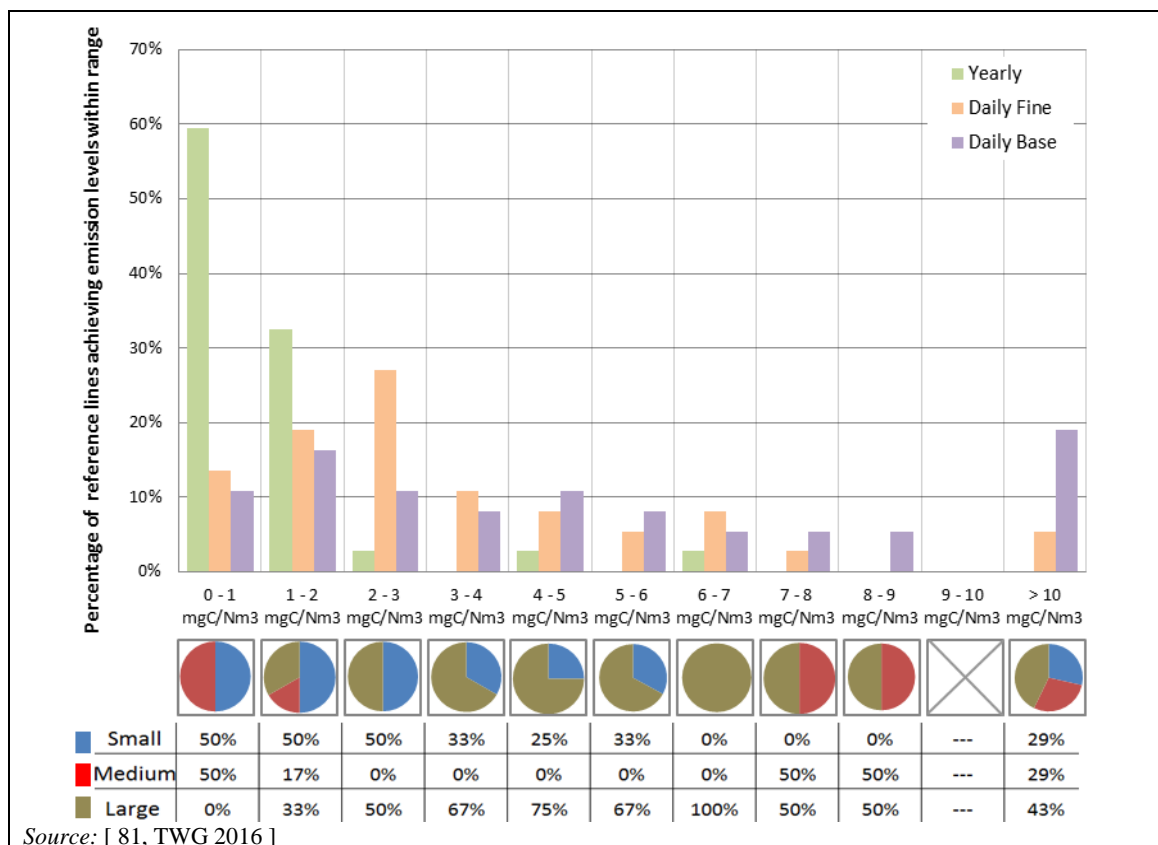

Source: [81, TWG 2016]

Figure 3.59: Continuously monitored TVOC emissions to air from reference lines incinerating predominantly HW

In all but two cases, the emission levels range between close to the limit of quantification and 2 mgC/Nm^3 as a yearly average and 8 mgC/Nm^3 as a maximum daily average ('fine' data filtering). In the case of some reference lines, the maximum daily average shows higher emission peaks when using the 'base' data filtering, generally related to OTNOC.

The reported data do not show a clear correlation between the achieved emission levels and the technique installed, the type and amount of reagent used or the age and size of the plant. Most plants are rotary kilns.

Carbon monoxide

Combustion efficiency is partly described by CO levels, which also indicates formation of other products of incomplete combustion.

CO is a pollutant typically associated with a low baseline emission but periodically showing sharp peak emissions due to sudden variations in local combustion conditions (e.g. variations in temperature in parts of the kiln). The monitoring and control of these peak emissions is an important aspect of the daily operation of an incinerator. With the pre-treatment of drummed waste and feed equalisation, it is possible to decrease CO peaks.

CO emission data from 38 reference lines incinerating predominantly HW, based on continuous measurements, are shown in Figure 3.60 in simplified form. The corresponding detailed graphs are Figure 8.50 of Annex 8.6 for daily and yearly emission levels, and Figure 8.103 of Annex 8.7 for half-hourly emission levels.

For each emission concentration range represented on the horizontal axis, the pie charts underneath show the shares of reference lines, among those achieving emission levels within the given range, that fall within different size classes (the thresholds for small, medium and large plants are described in the introductory text of Chapter 3).

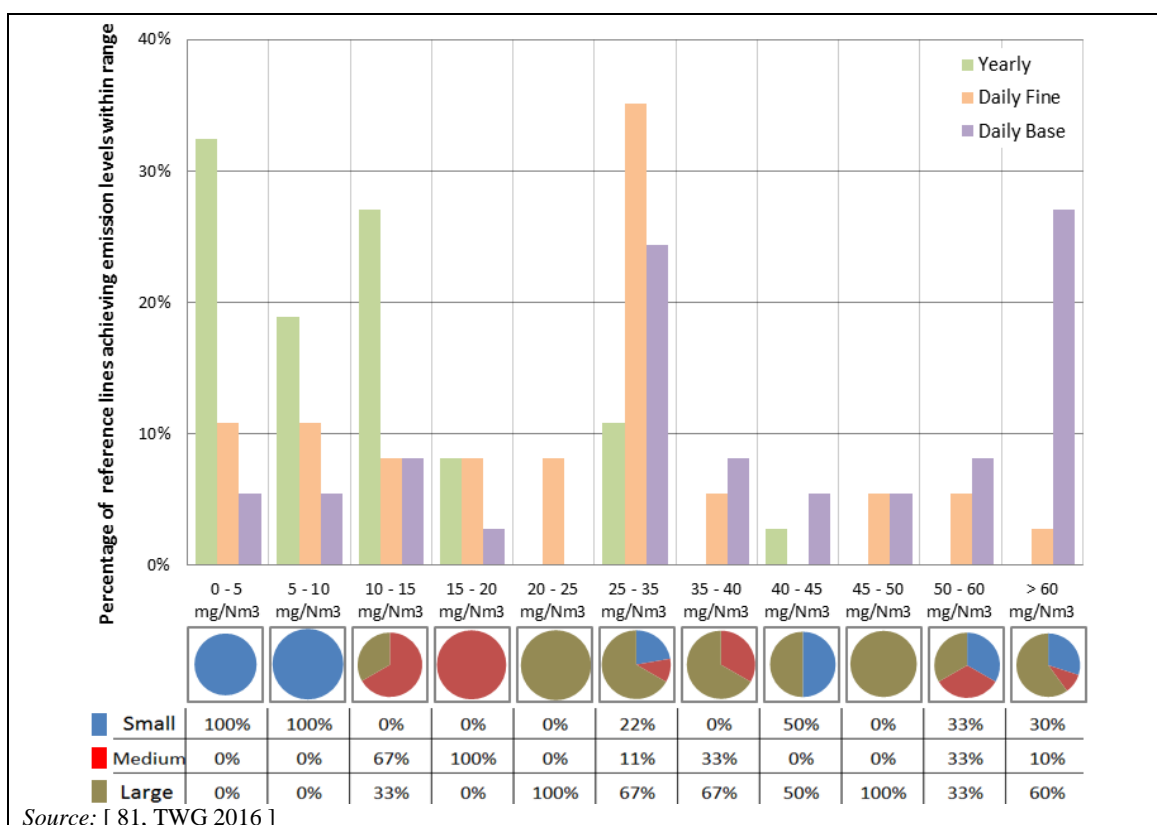

Figure 3.60: Continuously monitored CO emissions to air from reference lines incinerating predominantly HW

The emission levels range between close to the limit of quantification and 42 mg/Nm³ as a yearly average and between 2 mg/Nm³ and 72 mg/Nm³ as a maximum daily average ('fine' data filtering). Similar to TVOC emissions, in some cases higher emission peaks are observed in the values obtained under the 'base' data filtering, generally related to OTNOC.

The reported data do not show a clear correlation between the achieved emission levels and the technique installed, the type and amount of reagent used or the age and size of the plant.

PCDD/F, PCBs and PAHs

For reaching low levels of PCDD/F emissions, primary as well as secondary measures are important. In the firing system, effective mixing of the gases (high turbulence) improves the destruction of PCDD/F and similar compounds already present in the waste. Avoiding the temperature window for the recombination of PCDD/F and similar compounds in the boiler and flue-gas treatment system avoids the *de novo* synthesis of new PCDD/F.

For further reduction, four main types of techniques are in use:

1. static or moving-bed activated carbon filter;
2. bag filter with injection of activated carbon (usually mixed with other reagents);
3. destruction of gaseous PCDD/F on a catalyst;
4. PCDD/F adsorption on packing elements of carbon-impregnated polymer material in wet scrubbers or on static beds.

The use of activated carbon has the advantage of also reducing mercury emissions. Catalysts are mainly used to reduce NO_x emissions.

PCDD/F emission data from 37 reference lines incinerating predominantly HW, based on periodic measurements, are shown in simplified form in Figure 3.61. The corresponding detailed graph is Figure 8.142 of Annex 8.8.

For each emission concentration range represented on the horizontal axis, the pie charts underneath show the shares of reference lines, among those achieving emission levels within the given range, that are fitted with a fixed adsorption bed, without a fixed adsorption bed and a wet scrubber, and without a fixed adsorption bed and dry FGC techniques.

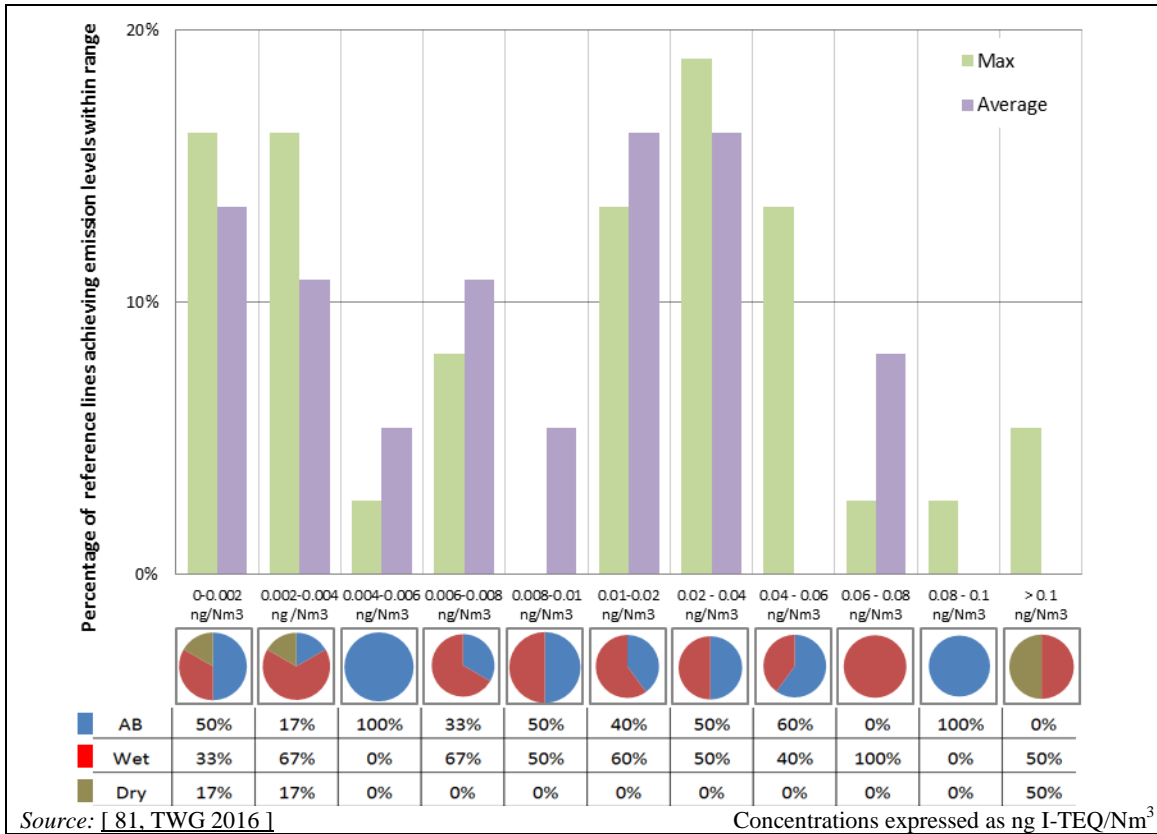

Figure 3.61: Periodically monitored PCDD/F emissions to air from reference lines incinerating predominantly HW

The emission levels range in all but five cases between close to the limit of quantification and 0.06 ng I-TEQ/Nm³, except for one reference line showing a level of 0.06 ng I-TEQ/Nm³, for both the average over the sampling period and the long-term sampling average. In three cases the maximum emission levels are above 0.1 ng I-TEQ/Nm³. All plants fitted with a fixed adsorption bed show emission levels below 0.1 ng I-TEQ/Nm³, and only one exceeds 0.06 ng I-TEQ/Nm³.

The reported data do not show a clear correlation between the achieved emission levels and the amount of reagent used or the age and size of the plant. Most plants are rotary kilns.

The PCDD/F emission data described so far only concern emissions measured periodically with a typical (short-term) sampling time of 6–8 hours. There is however also increasing experience with long-term sampling measurements of PCDD/F emissions sampled during periods of typically 2–4 weeks.

For the purpose of comparing the emission levels measured with short-term and with long-term sampling, emission data submitted by 142 reference lines, including 25 HWI lines, in Belgium and France that performed both long-term and short-term sampling measurements over the same period of time are presented and analysed in Annex 8.9.

Polychlorinated biphenyls (PCBs) and polycyclic aromatic hydrocarbons (PAHs) are removed by the same techniques as PCDD/F, meaning that an effective flue-gas cleaning system for PCDD/F will also deal with PCBs and PAHs.

Dioxin-like PCB emission data for plants incinerating predominantly HW are based on periodic measurements and are shown in Figure 8.143.

Six reference lines reported emission levels for dioxin-like PCBs. The maximum value recorded is 0.18 ng WHO-TEF. It is the only case where the emission level of dioxin-like PCBs is above the emission level of PCDD/F (see Figure 8.118).

PAH and BaP emission data are based on periodic measurements and are shown in Annex 8.8 in the following figures:

- Figure 8.144, PAH emissions from 9 reference lines incinerating predominantly HW;
- Figure 8.145, BaP emissions from 13 reference lines incinerating predominantly HW.

Emission levels range from 0.003 $\mu\text{g}/\text{Nm}^3$ to 21 $\mu\text{g}/\text{Nm}^3$ for PAHs. Reported BaP emissions are mostly below 0.025 $\mu\text{g}/\text{Nm}^3$, with three reference lines reporting levels between 0.2 $\mu\text{g}/\text{Nm}^3$ and 0.3 $\mu\text{g}/\text{Nm}^3$.

Mercury

The vast majority of plants use activated carbon, either as a fixed-bed system or in an entrained flow activated carbon injection system. The consumption rate as well as the quality of activated carbon (e.g. brominated or sulphur-impregnated) directly affect the emission levels. Other less frequently used techniques are the use of zeolites or the capture of mercury in the acidic wet scrubber, which can serve as a sink for mercury if it is present in the Hg(II) chloride form. The mercury that has been transferred from the gas stream to the scrubber liquor can then be removed by a waste water treatment plant.

If mercury is present in metallic form, the use of oxidation agents is needed; such as brominated activated carbon injection or boiler bromine addition. Some HW incineration plants use reagents such as hydrogen peroxide to promote the oxidation of mercury and thus significantly enhance its capture in the wet scrubber (see also mercury removal techniques). [74, TWG 2004]

Under certain conditions (e.g. high input rate of mercury), the removal capacity limits of the FGC systems may be exceeded, leading to temporarily elevated mercury emissions. This may be reflected by cases where the performance levels of a reference line for different averaging periods show large variations.

The mercury in the flue-gases originates from mercury-containing waste. There is a direct linear relationship between the amount of mercury in the raw flue-gases and the amount of mercury in the waste. For one installation equipped with wet gas scrubbing and an activated carbon filter, it is calculated that the total mercury input via the waste amounts to 1 000 kg/yr for an installation with an incineration capacity of 50 000 t/yr. Taking into account a maximum yearly emitted mercury flow via the flue-gases of less than 1.25 kg, this means a total removal efficiency of 99.99 %.

Installations with a continuously or temporarily high mercury input are able to take operational measures such as adding sulphur-containing reagents to the wet scrubbing system or injecting highly active brominated or sulphur-impregnated activated carbon to increase the mercury removal efficiency. The screening of the waste inputs for mercury and/or the continuous monitoring of mercury are therefore important.

Mercury emission data are based either on continuous or periodic measurement and are shown in the following figures, in simplified form within this chapter and in detail in Annex 8.6 and Annex 8.8; half-hourly emission levels are shown Annex 8.7:

- Figure 3.62, for the emission levels of 27 reference lines incinerating predominantly HW and monitoring Hg periodically. The corresponding detailed graph is Figure 8.146.
- Figure 3.63, for the daily and yearly emission levels of 11 reference lines incinerating predominantly HW and monitoring Hg continuously. The corresponding detailed graph is Figure 8.51.
- Figure 3.64, for the half-hourly emission levels of 11 reference lines incinerating predominantly HW and monitoring Hg continuously. The corresponding detailed graph is Figure 8.104.
- Figure 3.65, for the monthly emission levels of 11 reference lines incinerating predominantly HW and monitoring Hg continuously. The corresponding detailed graph is Figure 8.105.

For each emission concentration range represented on the horizontal axis, the pie charts underneath show the shares of reference lines, among those achieving emission levels within the given range, that are fitted with a fixed adsorption bed, without a fixed adsorption bed and a wet scrubber, and without a fixed adsorption bed and dry FGC techniques.

The monthly levels presented in Figure 3.65 are derived based on continuous monitoring data and provide an indication of the emission levels achieved when measuring mercury with an averaging period typical of long-term sampling methods. For monthly levels, which are hardly affected by short-term peaks, only the 'base' filtering mode is presented.

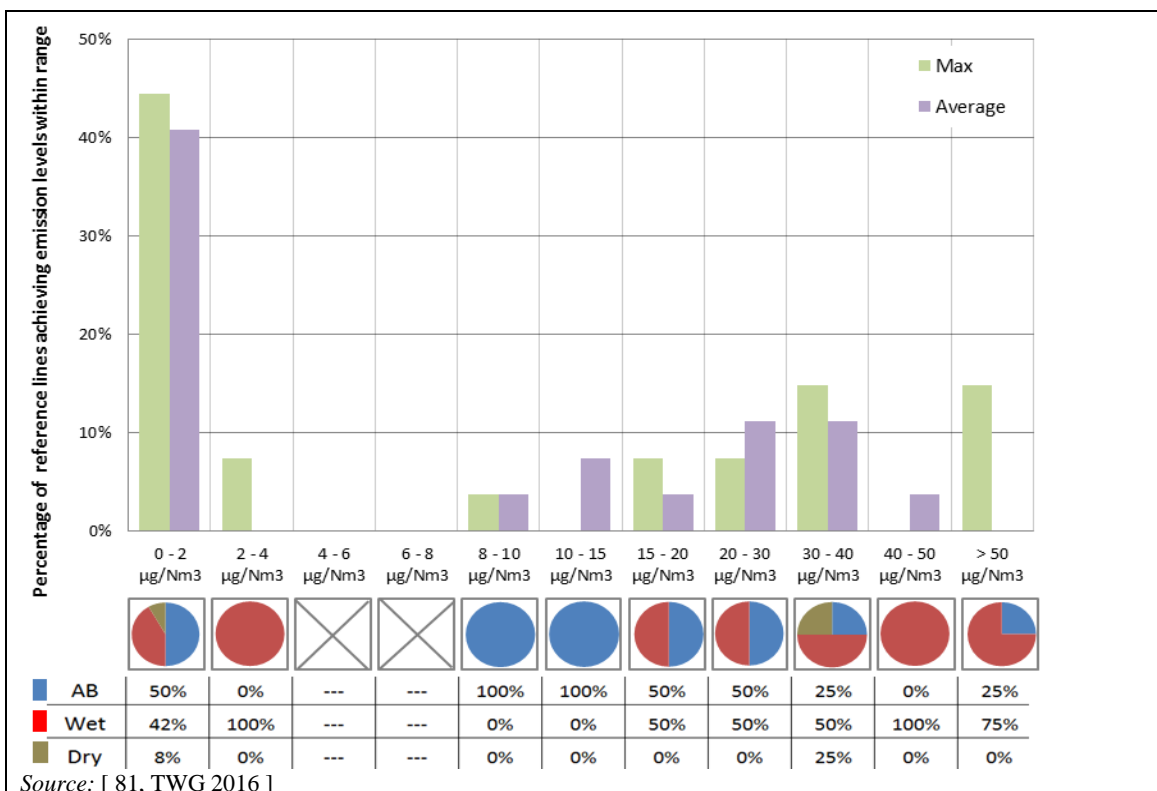

Figure 3.62: Periodically monitored mercury emissions to air from reference lines incinerating predominantly HW

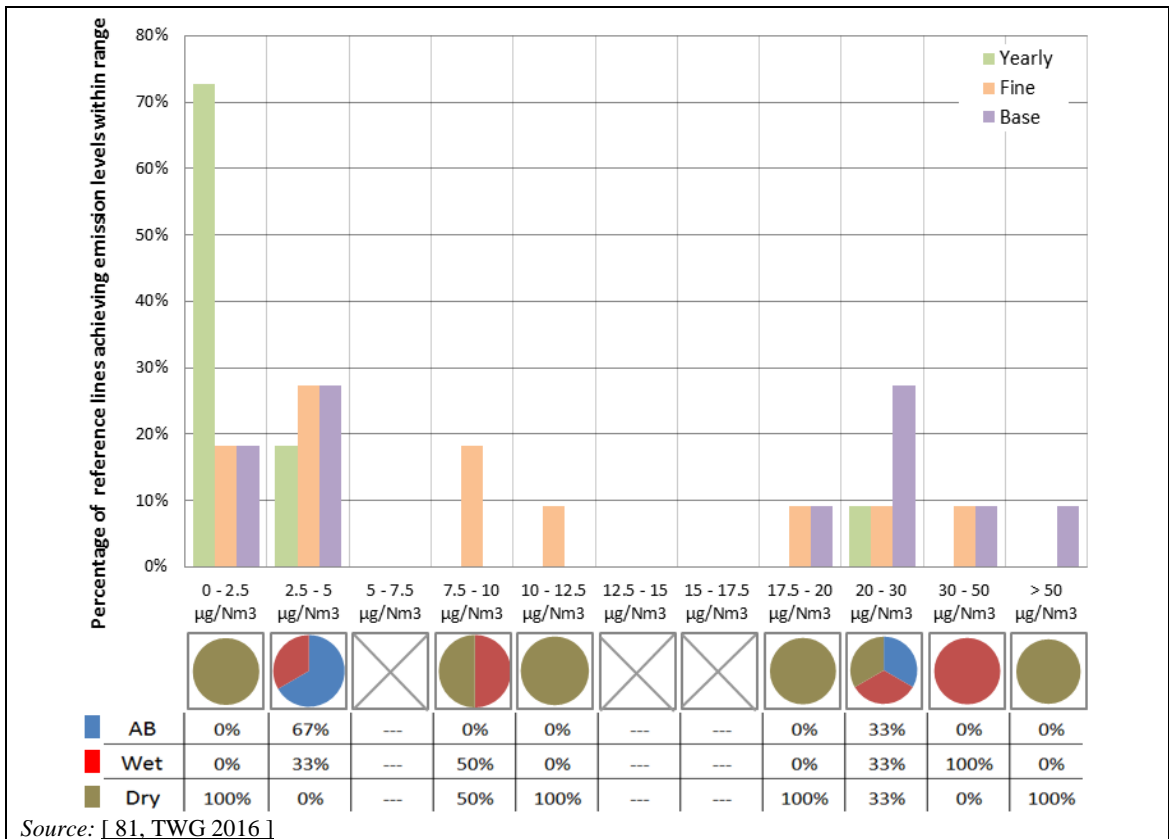

Figure 3.63: Continuously monitored mercury emissions to air from reference lines incinerating predominantly HW: daily and yearly emission levels

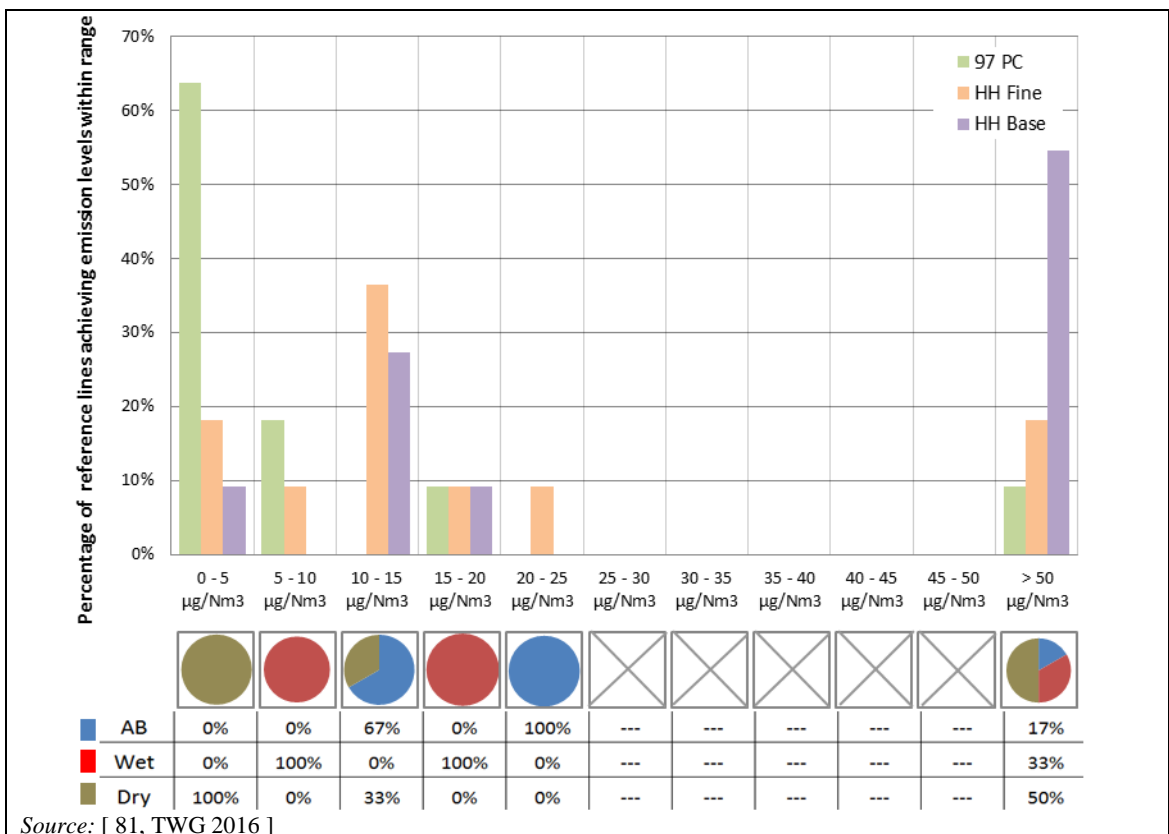

Figure 3.64: Continuously monitored mercury emissions to air from reference lines incinerating predominantly HW: half-hourly emission levels

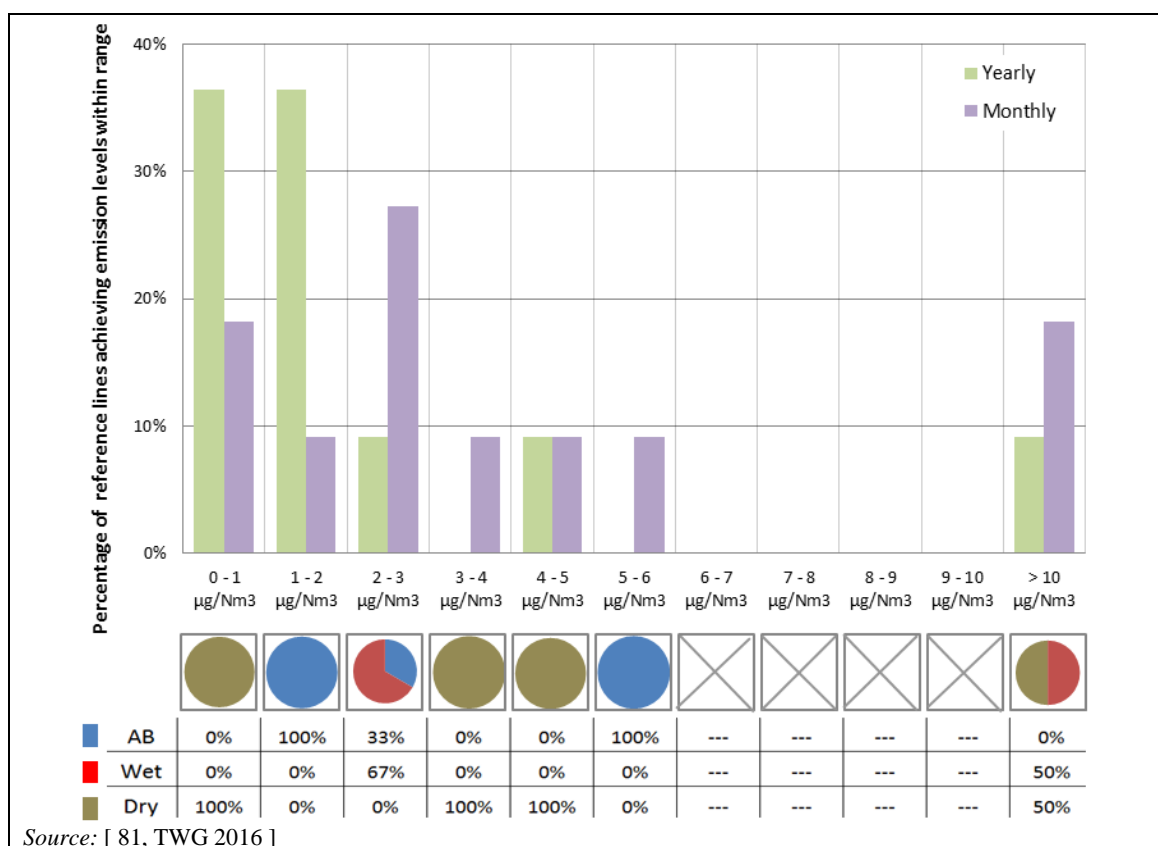

Figure 3.65: Continuously monitored mercury emissions to air from reference lines incinerating predominantly HW: monthly emission levels

With the exception of one plant (FR110), the emission levels range between close to the limit of quantification and 0.004 mg/Nm^3 as a yearly average, 0.01 mg/Nm^3 as a monthly average, and 0.024 mg/Nm^3 as a maximum daily average ('fine' data filtering). In certain cases the maximum daily average obtained with 'base' data filtering may be substantially higher (up to 0.036 mg/Nm^3), which may reflect not only high mercury input episodes, but also OTNOC situations where the daily average typically includes only a few half-hourly periods and where the mercury levels measured are elevated.

Plant FR110 reports 0.021 mg/Nm^3 as a yearly average, 0.04 mg/Nm^3 as a maximum monthly average, and maximum daily averages spanning the range from 0.032 mg/Nm^3 to 0.38 mg/Nm^3 with 'fine' and 'base' data filtering.

More than half of the plants that measure mercury periodically report averages over the sampling period below 0.003 mg/Nm^3 , eight plants report levels between 0.009 mg/Nm^3 and 0.038 mg/Nm^3 , and four plants report values between 0.054 mg/Nm^3 and 0.095 mg/Nm^3 . Most of the best performing plants use a fixed adsorption bed and/or inject hydrogen peroxide into the wet scrubber. One plant reporting the use of a wet scrubber with hydrogen peroxide (SE21R) reported a maximum level exceeding 0.06 mg/Nm^3 , but this was ascertained to relate to a malfunction of the waste water treatment plant, resulting in the re-injection of mercury-contaminated water into the quench system.

The reported data do not show a clear correlation between the achieved emission levels and the amount of activated carbon used or the age and size of the plant. Most plants are rotary kilns.

Antimony, arsenic, chromium, cobalt, copper, lead, manganese, nickel and vanadium

The techniques used to remove dust also reduce the emissions of dust-bound metals.

[Sb+As+Cr+Co+Cu+Pb+Mn+Ni+V] emission data, based on periodic measurements, are shown in simplified form in Figure 3.66, for 34 reference lines incinerating predominantly HW. The corresponding detailed graph is Figure 8.147 of Annex 8.8.

For each emission concentration range represented on the horizontal axis, the pie charts underneath show the shares of reference lines, among those achieving emission levels within the given range, that are fitted with a bag filter and with other techniques (such as ESPs).

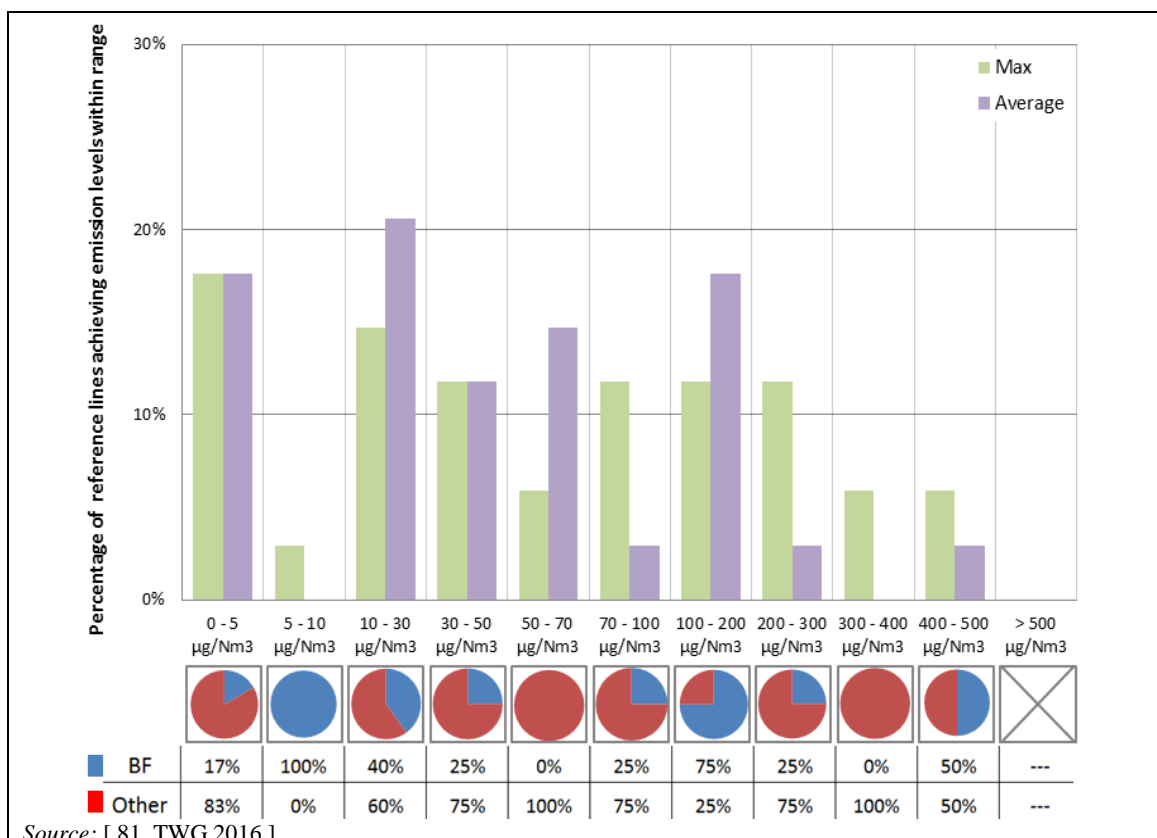

Figure 3.66: Periodically monitored Sb+As+Cr+Co+Cu+Pb+Mn+Ni+V emissions to air from reference lines incinerating predominantly HW

The emission levels range between close to the limit of quantification and 0.33 mg/Nm³, with the exception of two reference lines showing levels of 0.48 mg/Nm³, as a maximum of the averages over the sampling period.

All four plants reporting levels above 0.3 mg/Nm³ are small plants, and two of them are furnaces incinerating liquid residues from the chemical industry.

Cadmium and thallium

The techniques used to remove dust also reduce the emissions of dust-bound metals.

[Cd+Tl] emission data, based on periodic measurements, are shown in simplified form in Figure 3.67, for 32 reference lines incinerating predominantly HW. The corresponding detailed graph is Figure 8.148 of Annex 8.8.

For each emission concentration range represented on the horizontal axis, the pie charts underneath show the shares of reference lines, among those achieving emission levels within the given range, that are fitted with a bag filter and with other techniques (such as ESPs).

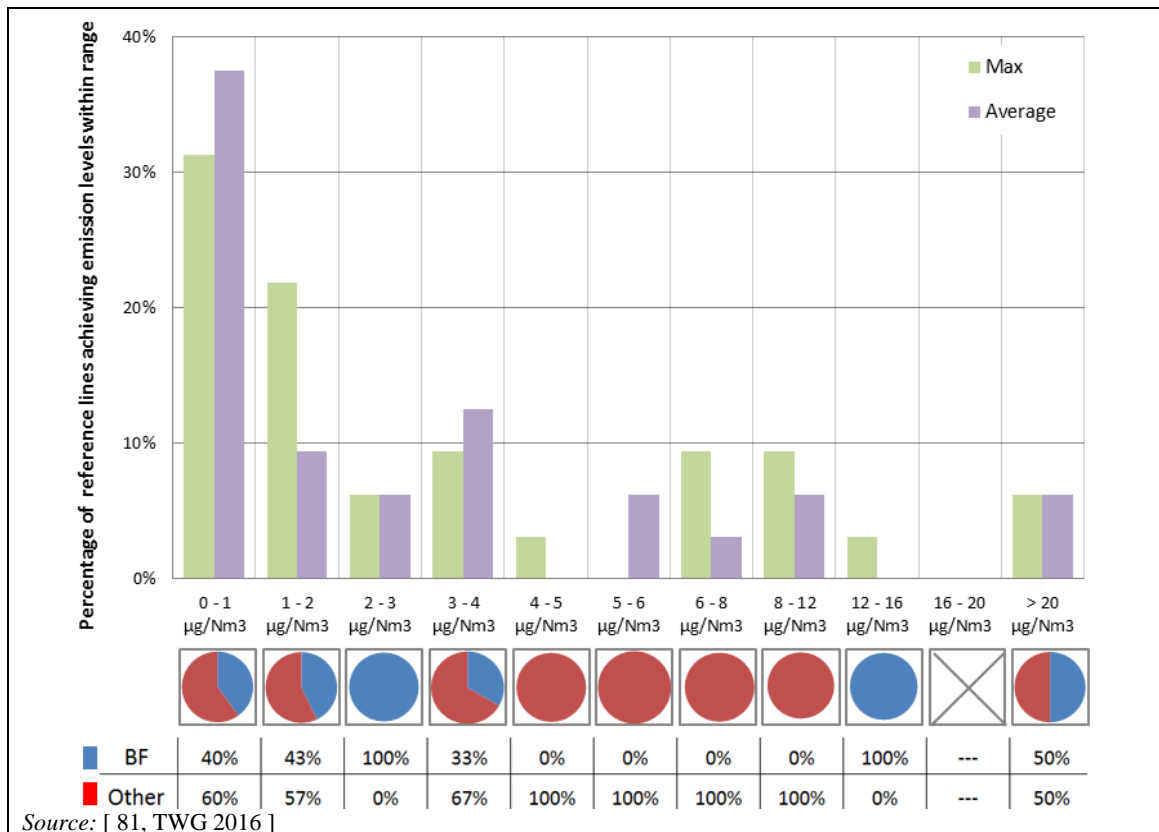

Figure 3.67: Periodically monitored Cd+Tl emissions to air from reference lines incinerating predominantly HW

The emission levels are between close to the limit of quantification and 0.021 mg/Nm³, with the exception of reference line FR107R, a furnace incinerating liquid residues from the chemical industry, reporting a level of 2.83 mg/Nm³, as a maximum of the averages over the sampling period.

The reported data do not show a clear correlation between the achieved emission levels and the technique installed, or the age and size of the plant.

3.2.2.4 Emissions to air from the incineration of clinical waste

The 2016 data collection includes three reference lines incinerating predominantly clinical waste. Only one of them provided sufficiently complete continuous monitoring data.

Table 3.7 summarises the continuously monitored data from a clinical waste incineration plant.

Table 3.7: Continuously monitored emissions from reference lines incinerating predominantly clinical waste

Ref. line	Techniques	NO _x (mg/Nm ³)			CO (mg/Nm ³)			Dust (mg/Nm ³)		
		Max. Daily Base	Max. Daily Fine	Yearly	Max. Daily Base	Max. Daily Fine	Yearly	Max. Daily Base	Max. Daily Fine	Yearly
NL04	BF, WS, DSI, SCR	91.7	91.7	63.9	46.5	23.0	10.5	0.14	0.14	0.09
NB: NL04 is a gasification plant (plant age = old and plant size = small). Techniques installed: BF = bag filter; WS = wet scrubber; DSI = dry sorbent injection; SCR = selective catalytic reduction. Source: [81, TWG 2016]										

The plant is a gasification plant fitted with SCR for the reduction of NO_x, achieving a value under 100 mg/Nm³ as a maximum daily average.

The yearly average CO emission level is 10.5 mg/Nm³ and the maximum daily average is 23 mg/Nm³ obtained with 'fine' data filtering and 46.5 mg/Nm³ with 'base' data filtering.

Reported dust emissions are extremely low and stable, with a minimal difference between the yearly average (0.09 mg/Nm³) and the maximum daily average (0.14 mg/Nm³). The reference line is fitted with a bag filter.

Table 3.8 and Table 3.9 summarise the periodically monitored emission data from the three reference lines incinerating predominantly clinical waste that participated in the 2016 data collection.

Table 3.8: Periodically monitored emissions from reference lines incinerating predominantly clinical waste (1/2)

Ref. line	Techniques	Reagents used	Hg (mg/Nm ³)		Cd+Tl (mg/Nm ³)		Sum metals (mg/Nm ³)	
			Max.	Avg.	Max.	Avg.	Max.	Avg.
UK14.1	BF, DSI	Hyd. lime, Active carbon	0.02	0.0003	0.004	0.001 0.2	0.202	0.160
UK14.2	BF, DSI	Hyd. lime, Active carbon	0.02	NI	0.004	NI	0.202	NI
NB: See notes of Table 3.9.								

Table 3.9: Periodically monitored emissions from reference lines incinerating predominantly clinical waste (2/2)

Ref. line	Techniques	Reagents used	HF (mg/Nm ³)		PCDD/F (ng I-TEQ/Nm ³)		PCBs (ng WHO-TEF/Nm ³)		PAH (µg/Nm ³)	
			Max.	Avg.	Max.	Avg.	Max.	Avg.	Max.	Avg.
UK14.1	BF, DSI	Hyd. lime, Active carbon	1.2	0.4	0.02	0.006	0.011	0.006	3.2	1.9
UK14.2	BF, DSI.	Hyd. lime, Active carbon	1.2	NI	0.02	NI	0.011	NI	3.2	NI
NL04	BF, WS, DSI, SCR	NI	0	NI	0.01	NI	NI	NI	NI	NI

NB:
 NI = No information provided.
 Emission data not provided: NH₃, BaP.
 UK14.1 and UK 14.2 are reference lines with furnace type = other, plant age = old installation / retrofitting to the current configuration after 2006 and size = small.
 NL04 is a gasification plant (plant age = old installation and plant size = small).
 Techniques installed: BF = bag filter; WS = wet scrubber; DSI = dry sorbent injection; SCR = selective catalytic reduction.
 Reagents used: Hyd. lime = High-surface / high-porosity hydrated lime.
 Source: [81, TWG 2016]

3.3 Emissions to water

3.3.1 Volumes of waste water arising from flue-gas cleaning

[1, UBA 2001]

The incineration process only produces a significant amount of waste water from wet FGC systems. Other types of flue-gas cleaning systems (dry and semi-dry) do not usually give rise to any effluent. In some cases the waste water from wet FGC systems is evaporated and in others it is treated and reused and/or discharged.

Table 3.10 shows examples of the typical quantities of scrubbing water arising from the flue-gas cleaning of waste incineration plants.

Table 3.10: Typical values of the amount of scrubbing water arising from FGC at waste incineration plants treating wastes with a low chlorine content

Plant type and waste throughput	Type of flue-gas cleaning	Approx. quantity of waste water (m ³ /tonne of waste)
Municipal waste incineration plant with a throughput of 250 000 t/yr	2 stages, with milk of lime	0.15 (design value)
Municipal waste incineration plant with a throughput of 250 000 t/yr	2 stages, with sodium hydroxide (before condensation facility)	0.3 (operating value)
Hazardous waste incineration plant with a throughput of 60 000 t/yr	2 stages, with milk of lime	0.15 (annual average)
Hazardous waste incineration plant with a throughput of 30 000 t/yr	2 stages, with sodium hydroxide	0.2 (annual average)

Source: [1, UBA 2001]

3.3.2 Other potential sources of waste water from waste incineration plants

[1, UBA 2001]

Besides the waste water from the flue-gas cleaning, waste water can also arise from a number of other sources.

Bottom ash collection, treatment and storage

Waste water from ash handling activities can normally be reused as the water supply for a wet bottom ash discharger, so it will not need to be discharged. It is, however, important to have sufficient storage (and treatment) capacity, to cope with fluctuations in storage levels caused by rainfall. Generally, the treatment options for excess water are: discharge to an available process waste water treatment system; discharge to the local sewerage system; and/or special disposal. This type of waste water can be reused in the FGC system if the quality is suitable, generally after treatment by sedimentation, filtration, etc.

Boiler operations

Waste water from the boilers (resulting from the preparation of boiler feed water and boiler drainage) can normally be reused in the incineration and FGC system so it will not need to be discharged. However, the recycling of waste water to the FGC system is only possible in the case of semi-wet or wet systems if the quality is suitable; otherwise, the waste water is discharged (mainly due to the high salt content).

Sanitary waste water

This originates from toilets, kitchens and cleaning. It is normally discharged to the sewerage system, for treatment in a municipal waste water treatment plant. A septic tank may be used if connection to the local sewage system is not possible. As this category of waste water is not specific to waste incineration, it is not discussed further in this document.

Clean rainwater

This arises from rain falling on unpolluted surfaces, such as roofs, service roads and parking places. Normally this 'clean' water is collected separately from process water and discharged directly to the local surface water or via soakaways. Pre-treatment may be required for rainwater from roads or parking areas.

Polluted rainwater

This arises from rain falling on polluted surfaces, such as unloading areas. It is usually segregated from clean rainwater and may be treated before use or discharge.

Cooling water

By far the largest cooling capacity is required where water condenser cooling is used, i.e. for electricity production with a steam turbine. Depending on the design of the plant, various cooling water streams will need to be disposed of, including:

- water from convection cooling of the condenser, which is connected to the steam turbine;
- water drained off from an evaporation cooling water system;
- water from various other pieces of equipment which require cooling; waste chute, hydraulic systems, strippers, etc.

These cooling water streams are not specific to waste incineration; they are described in the Reference document on the application of Best Available Techniques to Industrial Cooling Systems, published in December 2001.

Condensed waste water from the partial pre-drying of sewage sludge

This type of waste water is specific to sewage sludge incineration, although it does not arise in all cases as the steam generated during drying is sometimes evaporated with the incinerator flue-gas instead of being condensed. It generally has a high chemical oxygen demand (COD) and contains substantial concentrations of nitrogen (mainly NH_3), as well as other pollutants that were originally present in the treated sludge. The high nitrogen content can form a bottleneck for treatment; in this case stripping of nitrogen may be used, although there may be a risk of fouling and additional energy requirements for its operation. A solution in this case may be recycling into the furnace, when the recovered ammonia solution (concentration approximately 10 %) can be used for SNCR de- NO_x feed.

At the NL05 sewage sludge incineration plant, high amounts of volatile fatty acids (VFA) were found in the condensed waste water from the pre-drying of sewage sludge. Since VFA can interfere with the stripping of nitrogen, in this case the condensate is treated in the on-site waste water treatment plant. [7, TWG 2017]

In Table 3.11 the amount of waste water generated from some of the sources described above is presented.

Table 3.11: Other possible waste water sources, and their approximate quantities, from waste incineration plants

Waste water	Approx. amount	Occurrence
Chimney condensates after wet scrubbing	<ul style="list-style-type: none"> • 20 m³/d • 6 600 m³/yr 	Continuous
Wet ash removal/wet discharger	<ul style="list-style-type: none"> • 5 m³/d • 1 650 m³/yr 	
Reversible flow water from ion exchanger	<ul style="list-style-type: none"> • 1 m³/month • 120 m³/yr 	Discontinuous
Boiler water	<ul style="list-style-type: none"> • 500 m³/yr 	
Water from the cleaning of storage containers	<ul style="list-style-type: none"> • 800 m³/yr 	
Other cleaning water	<ul style="list-style-type: none"> • 300 m³/yr 	
Contaminated rainwater	<ul style="list-style-type: none"> • 200 m³/yr (Germany) 	
Laboratory water	<ul style="list-style-type: none"> • 200 m³/yr 	
NB: Data calculated on the basis of 330 operating days per year. Source: [1, UBA 2001]		

3.3.3 Plants free of process water releases

In some incineration plants, waste water arising from wet gas scrubbing is evaporated in the incineration process using a spray dryer. This can eliminate the need for effluent releases from the process.

In such cases, the waste water is generally pretreated in a waste water treatment plant (WWTP), before it is fed to the spray dryer. Treatment in a WWTP can help to prevent the recirculation and accumulation of some substances. Mercury recirculation is of particular concern, and specific reagents are usually added to provide a means of removing mercury from the system.

Salt (NaCl) can be recovered from the treated effluent for possible industrial uses, or may be collected in the FGC residues. [1, UBA 2001]

3.3.4 Plants with waste water discharges

[1, UBA 2001]

The treatment of waste water from the flue-gas cleaning in waste incineration plants is not fundamentally different from the treatment of waste water from other industrial processes.

Waste water from municipal waste incineration plants mainly contains the following substances:

- metals, including mercury;
- inorganic salts (chlorides, sulphates, etc.);
- organic compounds (phenols, PCDD/F).

The following table shows typical contamination levels of waste water from flue-gas cleaning facilities of municipal and hazardous waste incineration plants before the treatment of waste water.

Table 3.12: Typical contamination of waste water from wet FGC of waste incineration plants before treatment

Parameter	Municipal waste incineration			Hazardous waste incineration for common commercial plants		
	Minimum	Maximum	Average	Minimum	Maximum	Average
pH value	< 1	NI	NA	No data	No data	NA
Conductivity (µS)	NI	> 20 000	NI	NI	NI	NI
COD (mg/l)	140	390	260	NI	NI	22
TOC (mg/l)	47	105	73	NI	NI	NI
Sulphate (mg/l)	1 200	20 000	4 547	615	4 056	NI
Chloride (mg/l)	85 000	180 000	115 000	NI	NI	NI
Fluoride (mg/l)	6	170	25	7	48	NI
Hg (µg/l)	1 030	19 025	6 167	0.6	10	NI
Pb (mg/l)	0.05	0.92	0.25	0.01	0.68	NI
Cu (mg/l)	0.05	0.20	0.10	0.002	0.5	NI
Zn (mg/l)	0.39	2.01	0.69	0.03	3.7	NI
Cr (mg/l)	< 0.05	0.73	0.17	0.1	0.5	NI
Ni (mg/l)	0.05	0.54	0.24	0.04	0.5	NI
Cd (mg/l)	< 0.005	0.020	0.008	0.0009	0.5	NI
PCDD/F (ng/l)	NI	NI	NI	NI	NI	NI

NB: NA = not applicable; NI: No information available.
Source: [1, UBA 2001]

This section describes the emissions to water arising from treated flue-gas waste water streams.

Less information available than for emissions to air is available, reflecting the fact that most WI plants have no waste water emissions arising from the flue-gas cleaning system. The graphs show the maximum, the average and the minimum concentrations of the flow-proportional representative samples of the discharge taken over a period of 24 hours in 2014. The pollutant load emitted in 2014 is also shown.

The following contextual information is also shown in the graph: techniques in use relevant for the pollutant represented; prevalent waste burnt; plant size; plant age; number of samples considered for the reported emission values; and whether the waste water is released to a water body (direct discharge) or to a subsequent waste water treatment plant (indirect discharge).

Total suspended solids

Figure 3.68 shows the TSS emissions to water measured in 2014.

For each plant, along with the TSS emission levels and contextual information on the characteristics of the plant, the graph shows the waste water treatment techniques in use for the reduction of suspended solids; the techniques include:

- filtration;
- sedimentation;
- flotation;
- coagulation;
- flocculation.

The residual suspended solids in the discharged effluent may have the following three main origins:

- residual fractions of the precipitated components which are not removed by decantation or filtration;
- when groundwater containing Fe(II) is used in wet flue-gas cleaning, a slow oxidation of Fe(II) to Fe(III) and subsequent precipitation of Fe(OH)₃ can result in suspended solids where the residence time in the waste water treatment plant is shorter than the time the reaction needs to be completed;
- in other cases, the suspended solids can originate from post-precipitation reactions of sulphates and carbonates with Ca²⁺ which is present in the effluent or in other water streams which come into contact with the effluent before discharge and when the residence time is shorter than the time the reaction needs to be completed.

The emission levels range between close to the limit of quantification and 25 mg/l as an average of all the measurements in 2014 and 43 mg/l as a maximum. Of 12 plants that reported higher maximum emissions, the vast majority are related to indirect discharges, in which case the TSS load is expected to be reduced by the downstream waste water treatment plant.

The reported data do not show a clear correlation between the achieved emission levels and the size of the plant, the prevalent type of waste incinerated, or the applied techniques. However, it can be noted that lower emission levels are achieved by plants fitted with filtration (four plants have an average below 3 mg/l).

Mercury

Figure 3.69 shows the mercury emissions to water measured in 2014.

For each plant, along with the mercury emission levels and contextual information on the characteristics of the plant, the graph shows the waste water treatment techniques in use for the reduction of mercury; the techniques are the same that are shown also for all other metals in Figure 3.70 to Figure 3.79, and include:

- chemical precipitation;
- ion exchange;
- adsorption;
- filtration and sand filtration;
- sedimentation;
- flocculation;
- coagulation.

Mercury in the effluent originates from mercury contained in the waste. It is common practice that incinerators apply an input limit for the content of mercury in the waste incinerated.

For one plant incinerating hazardous waste and equipped with wet gas scrubbing, it is calculated that the total mercury input via the waste amounts to 2 000 kg/yr for an incineration capacity of 100 000 t/yr. Taking into account a maximum yearly emitted mercury flow via the waste water of less than 4 kg/yr, a removal efficiency higher than 99.8 % can be reached based on M-trimercaptotriazine precipitation and subsequent efficient removal of the precipitate.

The emission levels generally range between close to the limit of quantification and 0.006 mg/l as an average and 0.027 mg/l as a maximum. Higher emissions have been reported by 10 plants, possibly associated with other than normal operating conditions of the WWT plant and, in some cases, with inconsistent use of the units when reporting the data to express the concentration of this pollutant.

The graph shows that plants fitted with ion exchange and/or adsorption generally achieve lower emission levels (mostly below 0.001 mg/l as an average and 0.004 mg/l as a maximum). In general, plants incinerating predominantly hazardous waste have higher emissions than plants incinerating the other types of waste.

The reported data do not show a clear correlation between the achieved emission levels and the size of the plant.

Other metal and metalloid emissions

Metals and metalloids in the effluent originate from the substances contained in the waste. The waste water treatment technique used to decrease the metal emissions consists of chemical precipitation of metals as hydroxides and/or as metal sulphide components. Flocculation additives are used to optimise the precipitation. Filtration is generally used in addition to coagulation and sedimentation or chemical precipitation. For further reduction of their concentration, adsorption and ion exchange are used.

A total of 16 plants, almost half of which Austrian, reported data on antimony emissions to water. The emission levels generally range between close to the limit of quantification and 0.6 mg/l as an average of all the measurements in 2014 and 0.9 mg/l as a maximum. Four plants reported higher emissions.

According to Austrian operators, the antimony concentrations in the effluents from waste incineration plants have been on the rise in recent years. While the causes have not been fully clarified, possible antimony sources have been identified in catalysts used in PET production, in the antimony content in automotive brake linings, and in the use of antimony compounds as flame inhibitors in textiles.

The reported data do not show a clear correlation between the achieved emission levels and the size of the plant or the applied techniques. However, it can be noted that higher emission levels are reported by plants incinerating hazardous waste (three plants report a maximum between 0.9 mg/l and 20 mg/l).

Figure 3.71 shows arsenic emissions to water measured in 2014.

The emission levels generally range between close to the limit of quantification and 0.01 mg/l as an average of all the measurements in 2014 and 0.1 mg/l as a maximum. Nine plants reported higher emissions, possibly associated with other than normal operating conditions of the WWT plant and, in some cases, with inconsistent use of the units when reporting the data.

The reported data show that larger plants achieve lower emissions than medium or smaller plants. The reported data do not show a clear correlation between the achieved emission levels and the prevalent type of waste incinerated or the size of the plant. It can be noted that, in general, lower emission levels are reported by plants using adsorption.

Figure 3.72 shows cadmium emissions to water measured in 2014.

The emission levels generally range between close to the limit of quantification and 0.025 mg/l as an average of all the measurements in 2014 and 0.05 mg/l as a maximum. A total of 11 plants reported higher maximum emissions, possibly associated with other than normal operating conditions of the WWT plant and, in some cases, with inconsistent use of the units when reporting the data.

The reported data do not show a clear correlation between the achieved emission levels and the size of the plant, the prevalent type of waste incinerated, or the applied techniques.

Figure 3.73 shows chromium emissions to water measured in 2014.

The emission levels range between close to the limit of quantification and 0.16 mg/l as an average of all the measurements in 2014 and 0.3 mg/l as a maximum. Four plants reported higher maximum emissions, possibly associated with other than normal operating conditions of the WWT plant and, in some cases, with inconsistent use of the units when reporting the data.

The reported data do not show a clear correlation between the achieved emission levels and the size of the plant, the prevalent type of waste incinerated, or the applied techniques.

Figure 3.74 shows copper emissions to water measured in 2014.

The emission levels range between close to the limit of quantification and 0.3 mg/l as an average of all the measurements in 2014 and 0.5 mg/l as a maximum. Seven plants reported higher maximum emissions, possibly associated with other than normal operating conditions of the WWT plant and, in some cases, with inconsistent use of the units when reporting the data.

The graph shows that plants using adsorption and/or ion exchange generally achieve emission levels below 0.05 mg/l.

The reported data do not show a clear correlation between the achieved emission levels and the size of the plant or the prevalent type of waste incinerated.

Figure 3.75 shows lead emissions to water measured in 2014.

The emission levels range between close to the limit of quantification and 0.05 mg/l as an average of all the measurements in 2014 and 0.2 mg/l as a maximum. A total of 10 plants reported higher maximum emissions, possibly associated with other than normal operating conditions of the WWT plant and, in some cases, with inconsistent use of the units when reporting the data.

The graph shows that plants using adsorption and ion exchange generally achieve emission levels below 0.05 mg/l.

The reported data do not show a clear correlation between the achieved emission levels and the size of the plant or the prevalent type of waste incinerated.

Figure 3.76 shows molybdenum emissions to water measured in 2014.

Only three plants reported data on direct molybdenum emissions to water, ranging between 0.02 mg/l and 0.04 mg/l as a maximum of all the measurements in 2014. One plant reported indirect molybdenum emissions to water, with a substantially higher maximum of around 7 mg/l.

The reported data do not show a clear correlation between the achieved emission levels and the size of the plant, the applied techniques or the prevalent type of waste incinerated.

Figure 3.77 shows nickel emissions to water measured in 2014.

The emission levels range between close to the limit of quantification and 0.03 mg/l as an average of all the measurements in 2014 and 0.04 mg/l as a maximum. Six plants reported higher maximum emissions, possibly associated with other than normal operating conditions of the WWT plant and, in some cases, with inconsistent use of the units when reporting the data.

The reported data do not show a clear correlation between the achieved emission levels and the applied techniques, the size of the plant or the prevalent type of waste incinerated.

Figure 3.78 shows thallium emissions to water measured in 2014.

The emission levels range between close to the limit of quantification and 0.025 mg/l as an average of all the measurements in 2014 and 0.05 mg/l as a maximum. Five plants reported higher maximum emissions, possibly associated with other than normal operating conditions of the WWT plant.

The reported data do not show a clear correlation between the achieved emission levels and the applied techniques, the size of the plant or the prevalent type of waste incinerated.

Figure 3.79 shows zinc emissions to water measured in 2014.

The emission levels range between close to the limit of quantification and 0.54 mg/l as an average of all the measurements in 2014 and 1.5 mg/l as a maximum. Three plants reported higher maximum emissions, possibly associated with other than normal operating conditions of the WWT plant and, in some cases, with inconsistent use of the units when reporting the data.

The graph shows that plants using adsorption and ion exchange generally achieve emission levels below 0.4 mg/l.

The reported data do not show a clear correlation between the achieved emission levels and the size of the plant or the prevalent type of waste incinerated.

Total organic carbon (TOC)

In order to reduce emissions to water of TOC, primary techniques (e.g. reduction of the emitted load of organic carbon by optimisation of the incineration process) are applied. In addition to these, adsorption with activated carbon and filtration are also used as specific techniques for the abatement of TOC.

Figure 3.80 shows TOC emissions to water measured in 2014.

For each plant, along with the TOC emission levels and contextual information on the characteristics of the plant, the graph shows the waste water treatment techniques in use for the reduction of TOC; the techniques include:

- oxidation;
- adsorption;
- filtration and sand filtration.

In the case of direct discharges, the emission levels range between 1.4 mg/l and 12 mg/l as an average of all the measurements in 2014 and 38 mg/l as a maximum. One plant reported an average of 364 measurements of 6.4 mg/l and a maximum of 86 mg/l. Several plants associated with indirect discharges reported substantially higher TOC levels (up to 1.3 g/l); in these cases the TOC load is expected to be reduced by the downstream waste water treatment plant.

The graph shows that plants using a combination of adsorption and filtration achieve emission levels of around 9 mg/l.

The reported data do not show a clear correlation between the achieved emission levels and the size of the plant or the prevalent type of waste incinerated.

Polychlorinated dibenzo-dioxins and furans (PCDD/F)

In order to reduce the water emissions of PCDD/F, primary techniques such as the optimisation of the incineration process and/or avoidance of the conditions for *de novo* synthesis are applied. In addition to these, adsorption with activated carbon is also used as a specific technique for the abatement of PCDD/F.

Figure 3.81 shows PCDD/F emissions to water measured in 2014.

For each plant, along with the PCDD/F emission levels and contextual information on the characteristics of the plant, the graph shows the waste water treatment techniques in use for the reduction of PCDD/F, or that may have the ancillary benefit of reducing PCDD/F emissions; the techniques include:

- oxidation;
- ion exchange;
- adsorption;
- filtration and sand filtration;
- sedimentation;
- flocculation;
- coagulation.

The emission levels range between close to the limit of quantification and 0.09 ng/l as an average of all the measurements in 2014 and 0.18 ng/l as a maximum, with the exception of one plant reporting 0.35 ng/l as a maximum.

The graph shows that plants using microfiltration achieve emission levels of around 0.009 ng/l.

The reported data do not show a clear correlation between the achieved emission levels and the size of the plant or the prevalent type of waste incinerated.

Chloride and sulphate content

[41, EURITS 2002] The amount of chloride in the effluent shows a linear relationship with the amount of chlorine in the waste in the input to the incinerator.

The sulphate content in the effluent is reduced in most installations by the partial precipitation of gypsum, so that the discharged concentration of SO_4^{2-} is between 1 g/l and 2 g/l. [122, COM 2006]

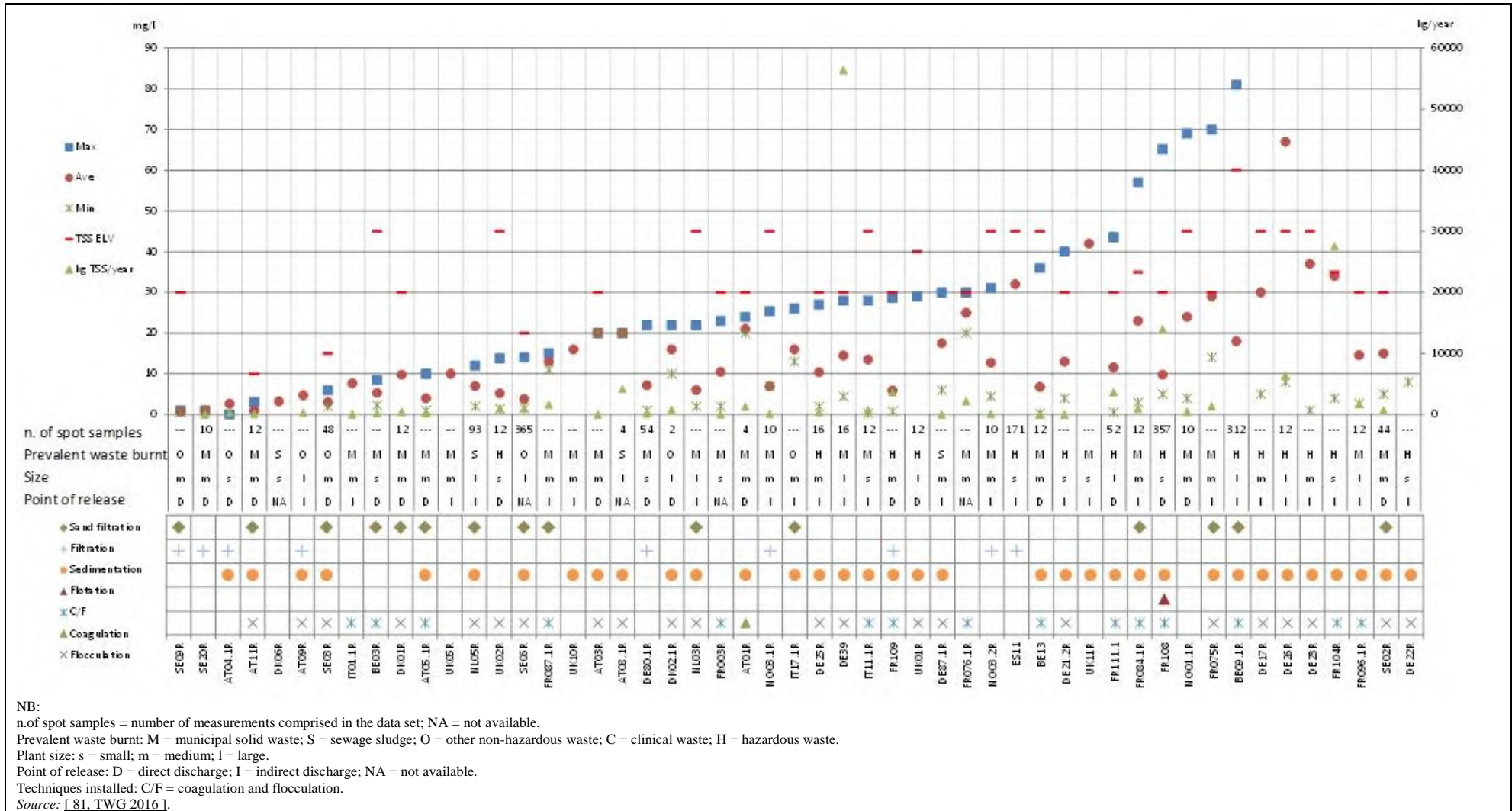

Figure 3.68: Total suspended solid emissions to water and abatement techniques applied

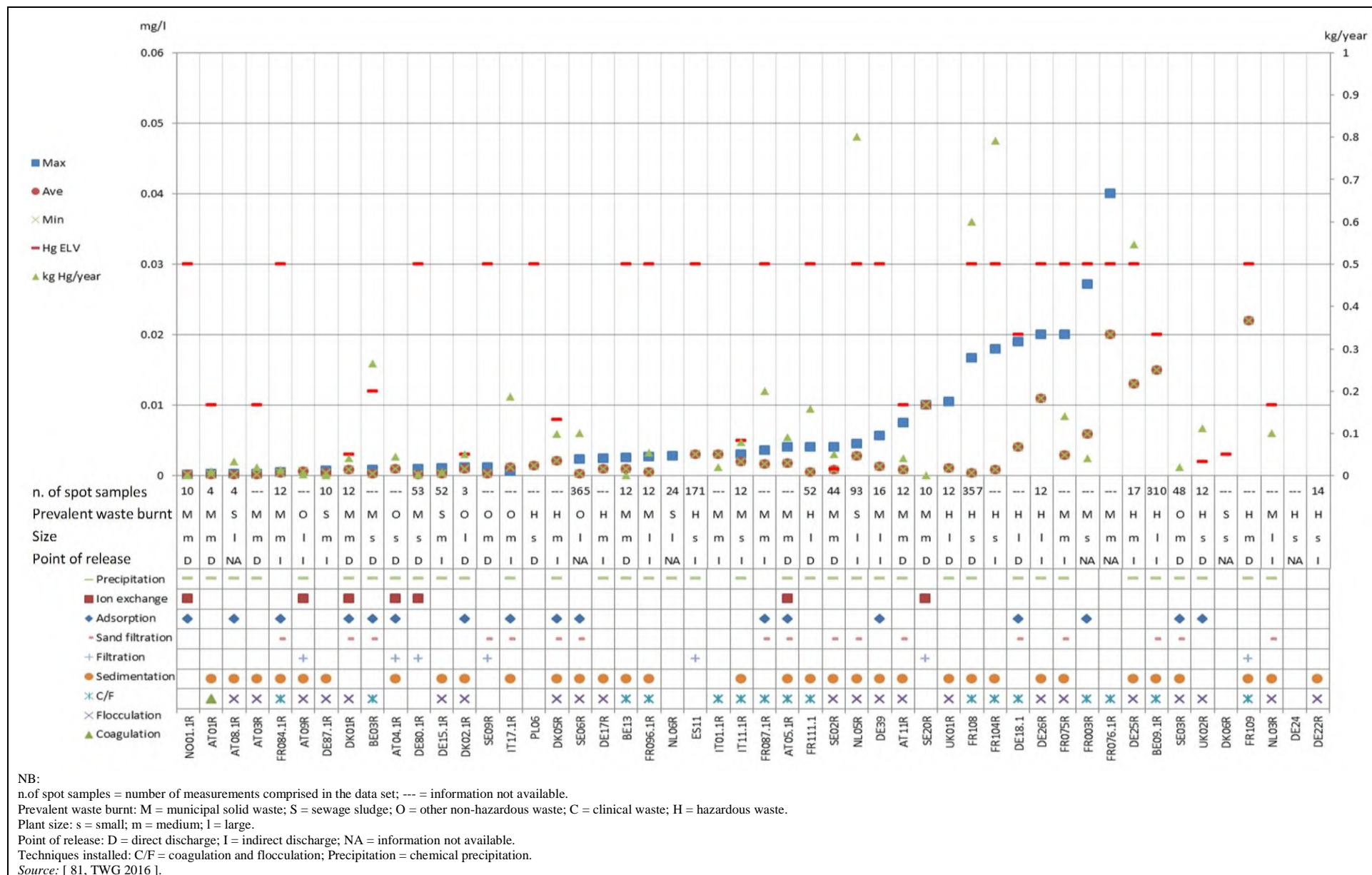

Figure 3.69: Mercury emissions to water and abatement techniques applied

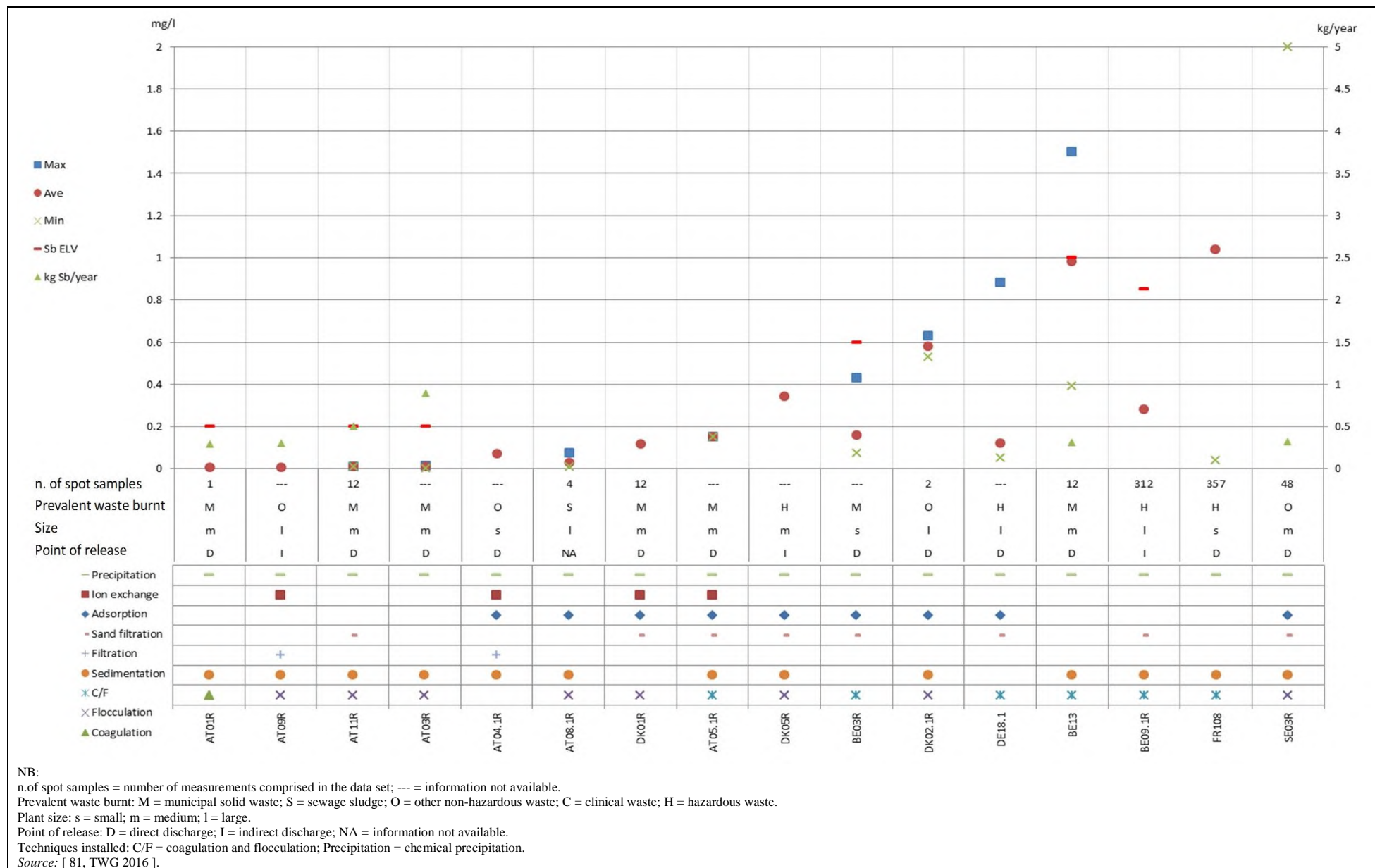

Figure 3.70: Antimony emissions to water and abatement techniques applied

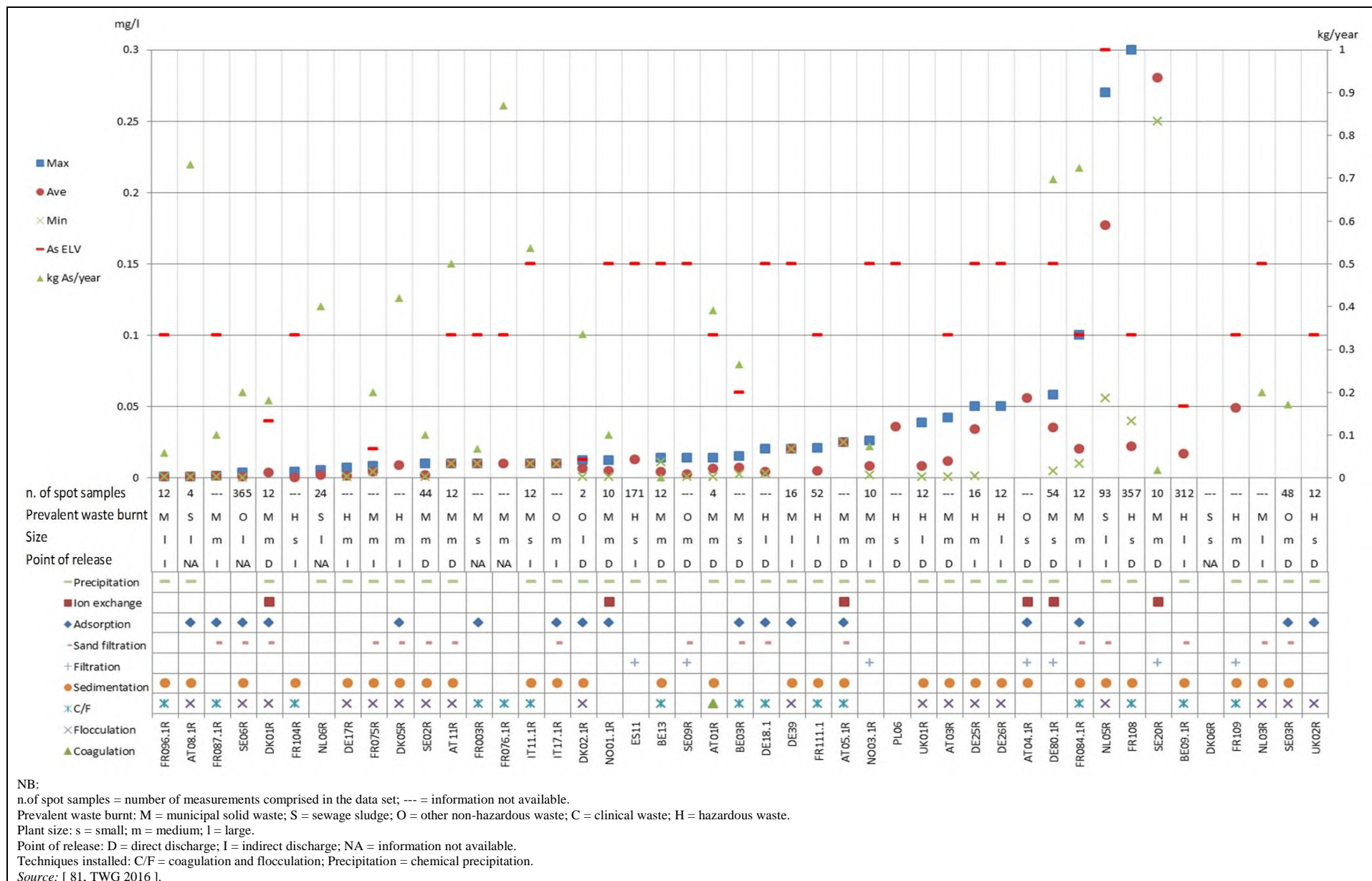

Figure 3.71: Arsenic emissions to water and abatement techniques applied

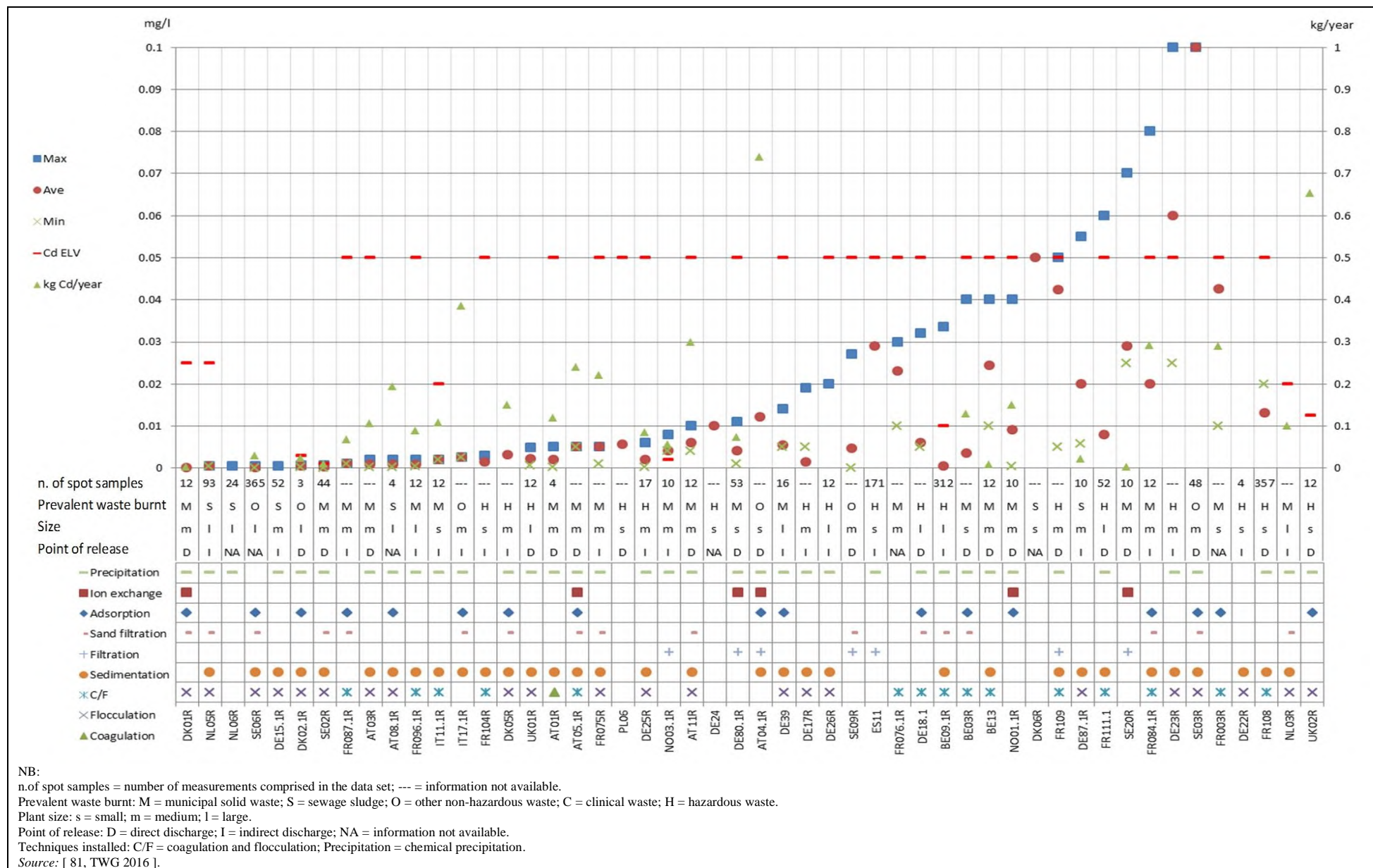

Figure 3.72: Cadmium emissions to water and abatement techniques applied

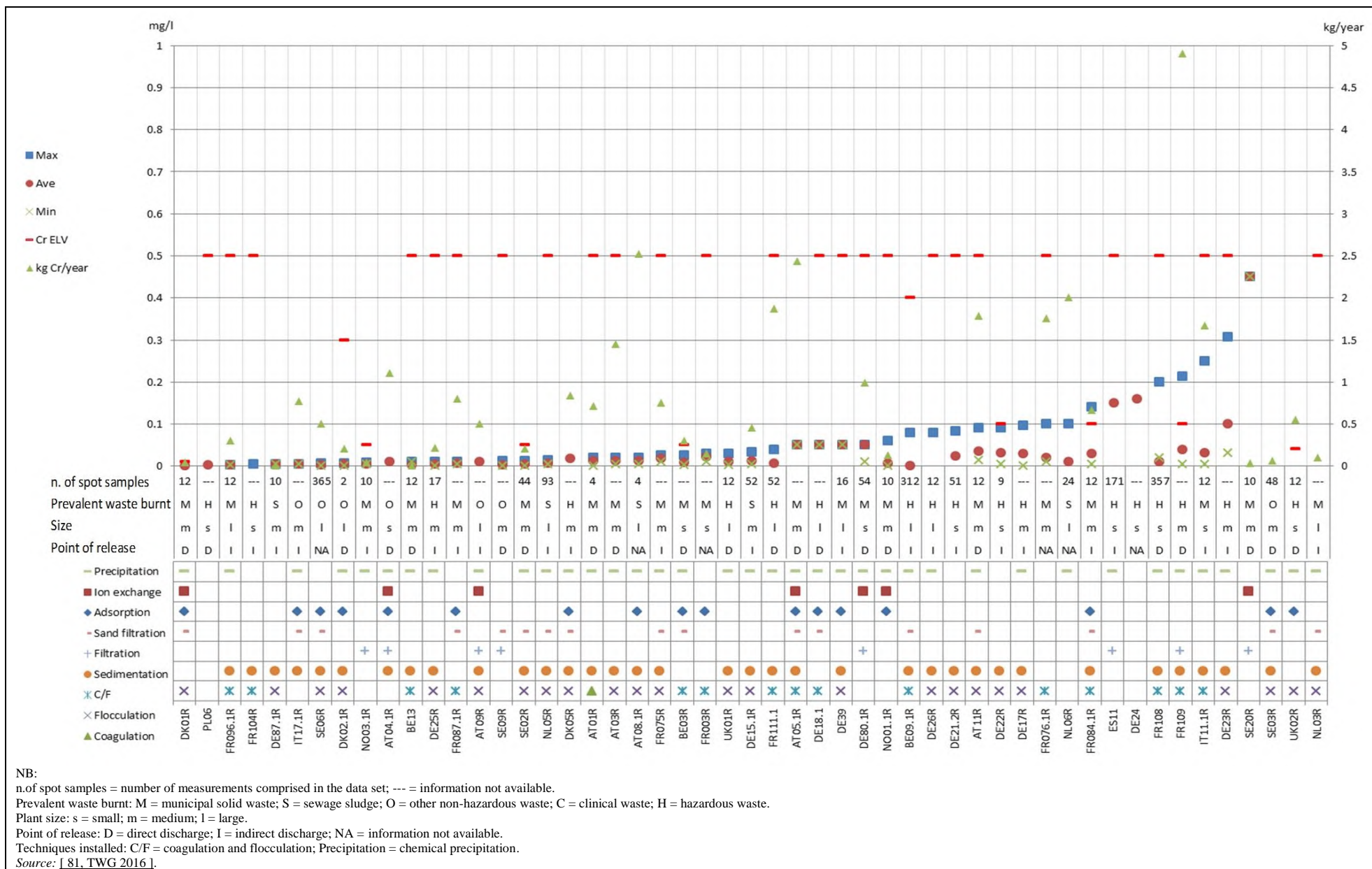

Figure 3.73: Chromium emissions to water and abatement techniques applied

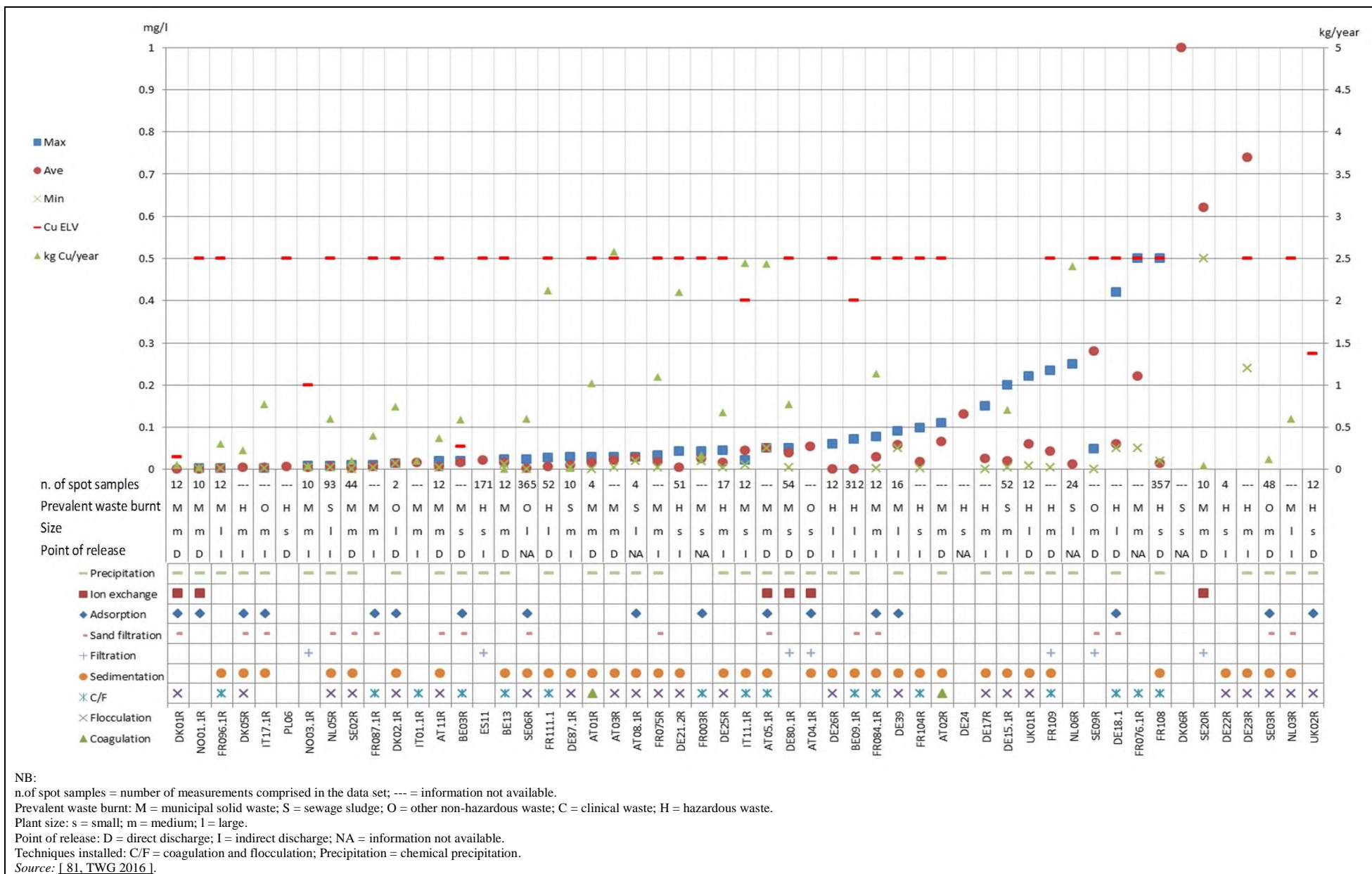
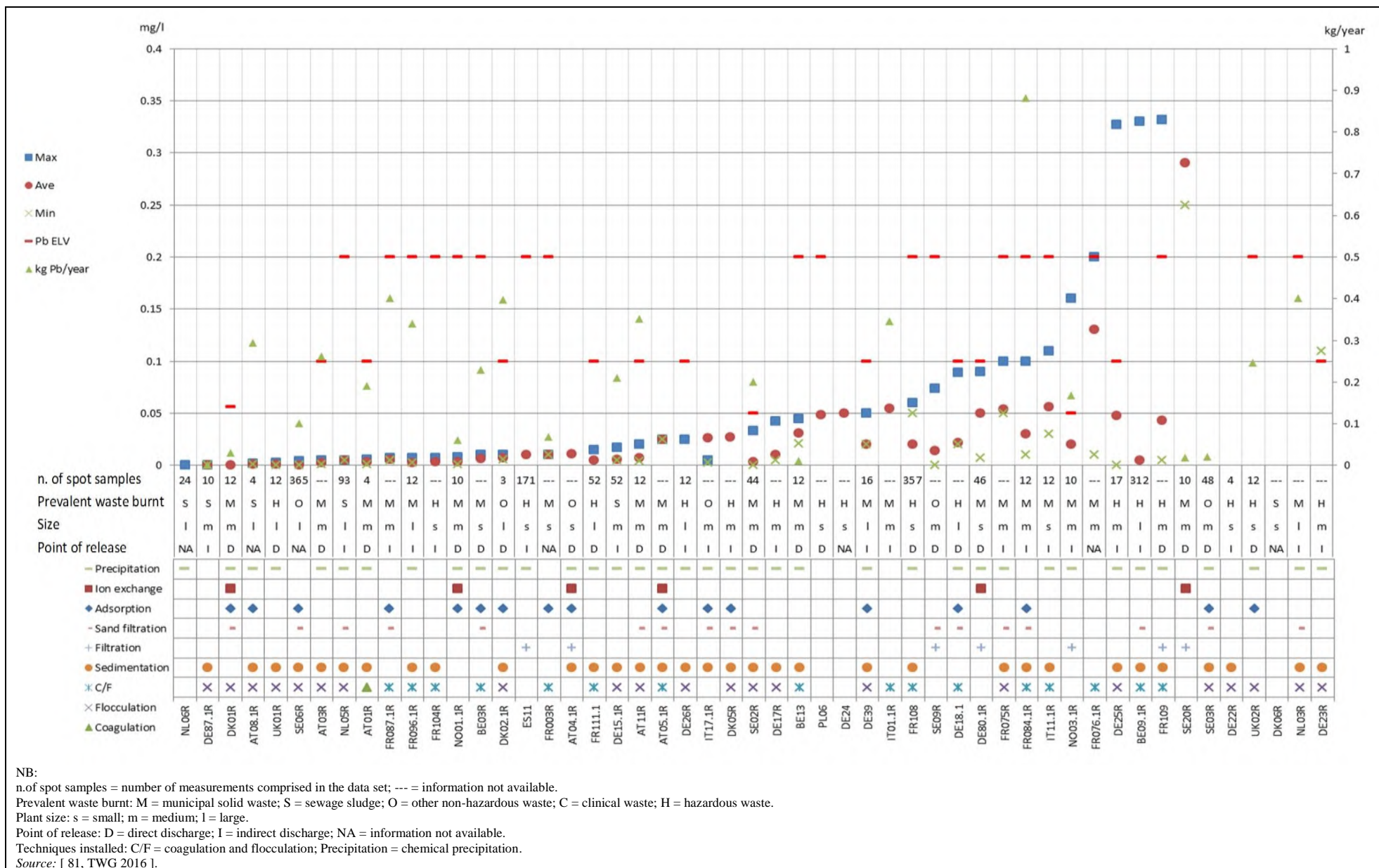

Figure 3.74: Copper emissions to water and abatement techniques applied



NB:
n. of spot samples = number of measurements comprised in the data set; --- = information not available.
Prevalent waste burnt: M = municipal solid waste; S = sewage sludge; O = other non-hazardous waste; C = clinical waste; H = hazardous waste.
Plant size: s = small; m = medium; l = large.
Point of release: D = direct discharge; I = indirect discharge; NA = information not available.
Techniques installed: C/F = coagulation and flocculation; Precipitation = chemical precipitation.
Source: [81, TWG 2016].

Figure 3.75: Lead emissions to water and abatement techniques applied

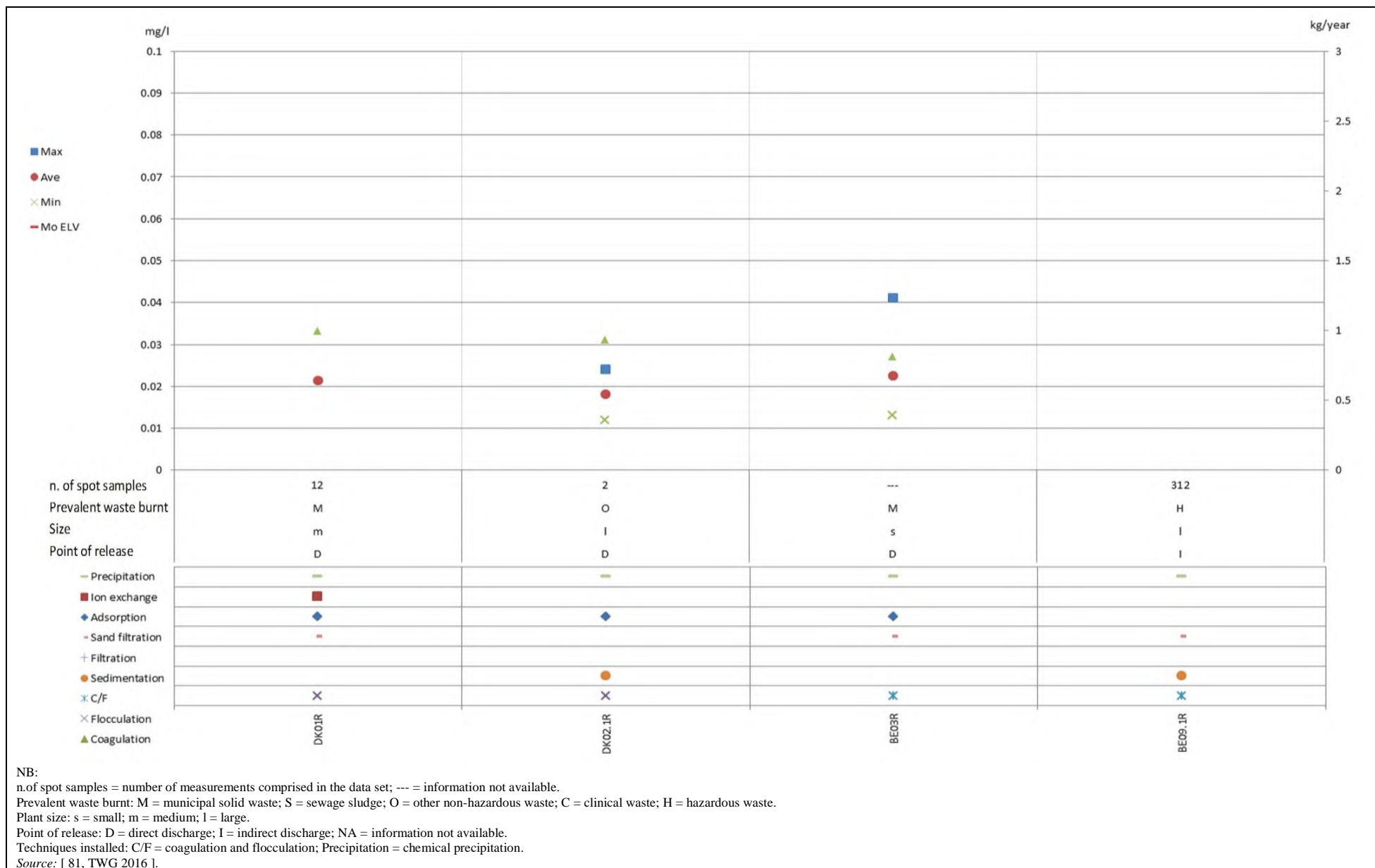

Figure 3.76: Molybdenum emissions to water and abatement techniques applied

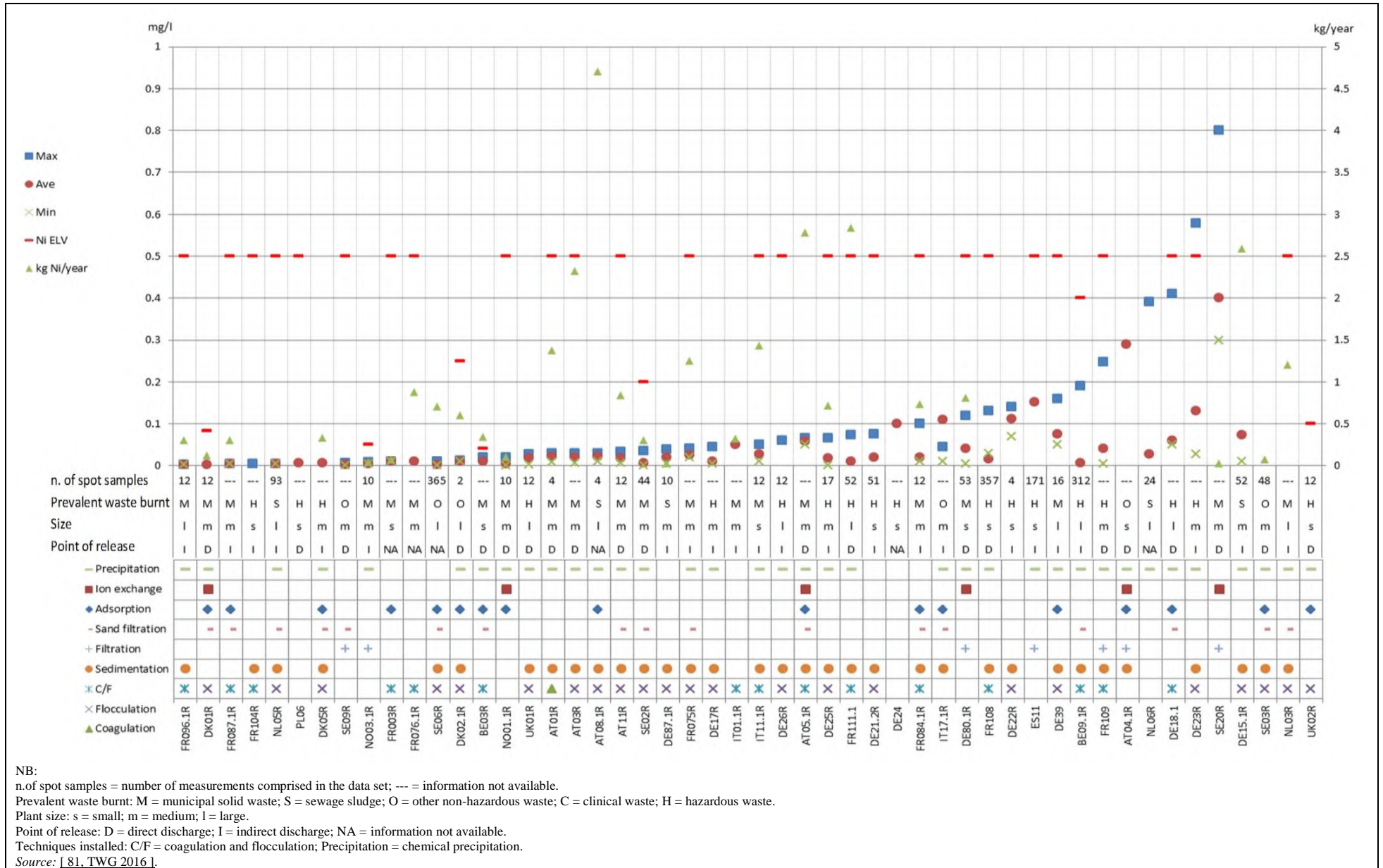

Figure 3.77: Nickel emissions to water and abatement techniques applied

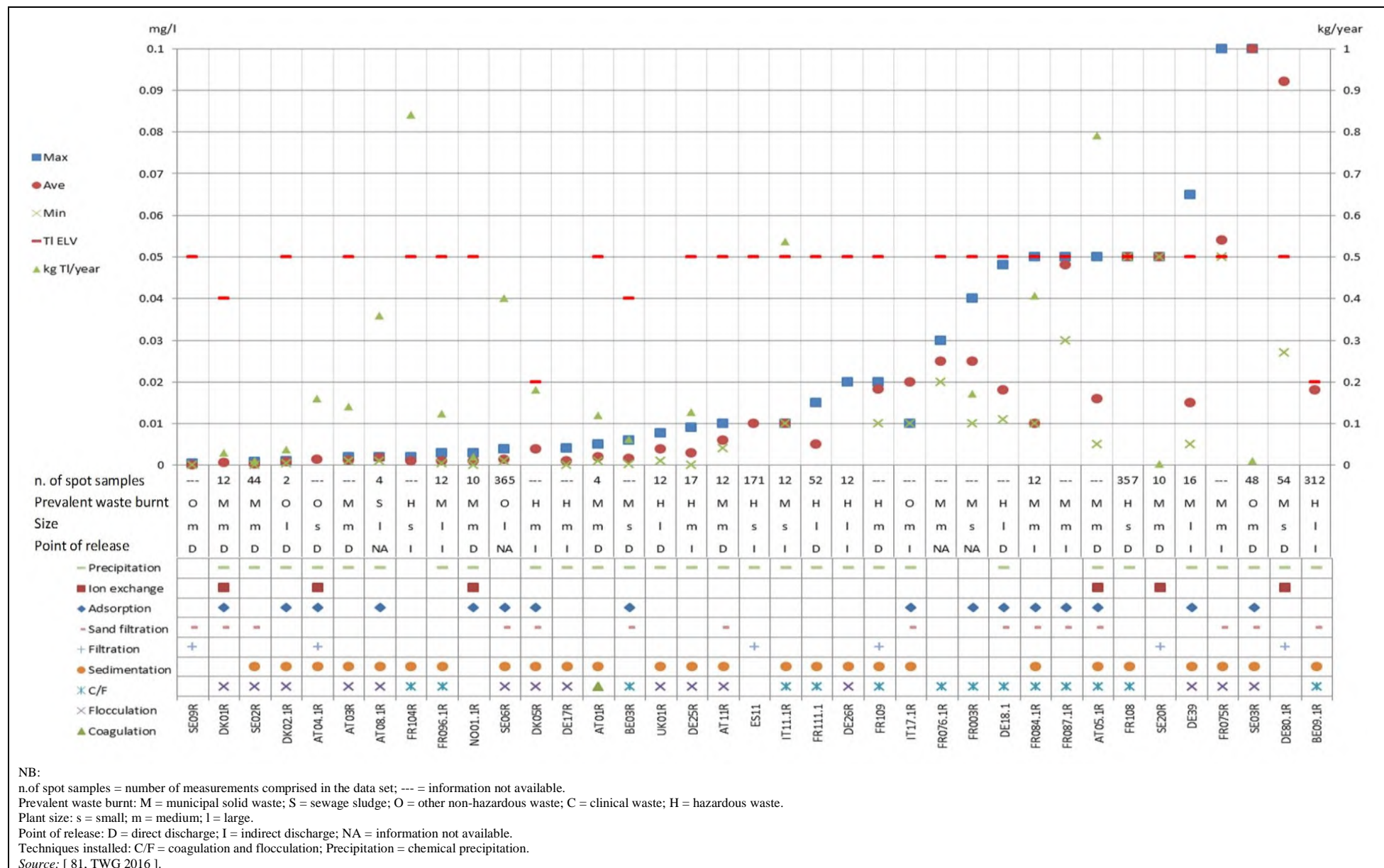

Figure 3.78: Thallium emissions to water and abatement techniques applied

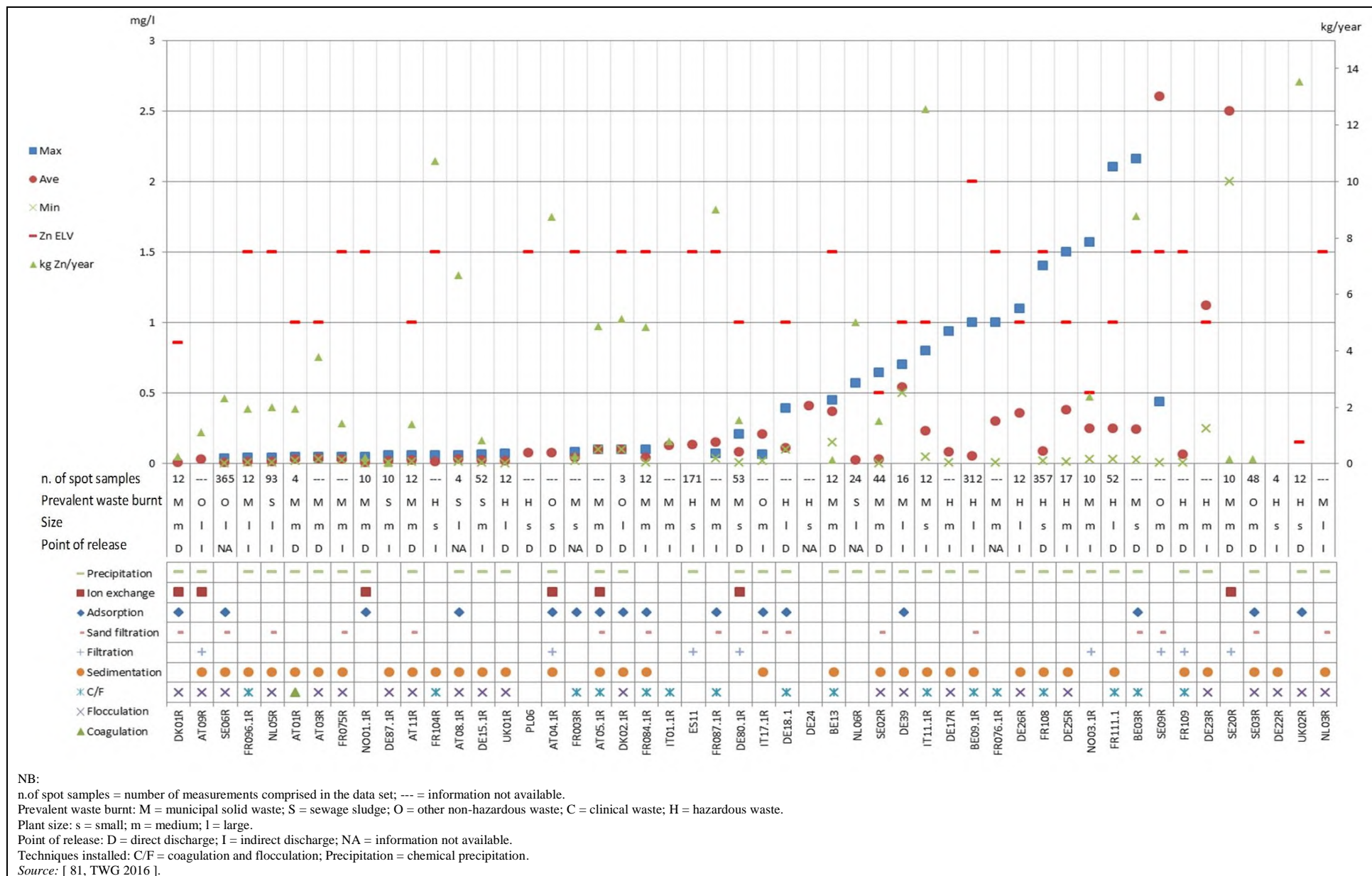

Figure 3.79: Zinc emissions to water and abatement techniques applied

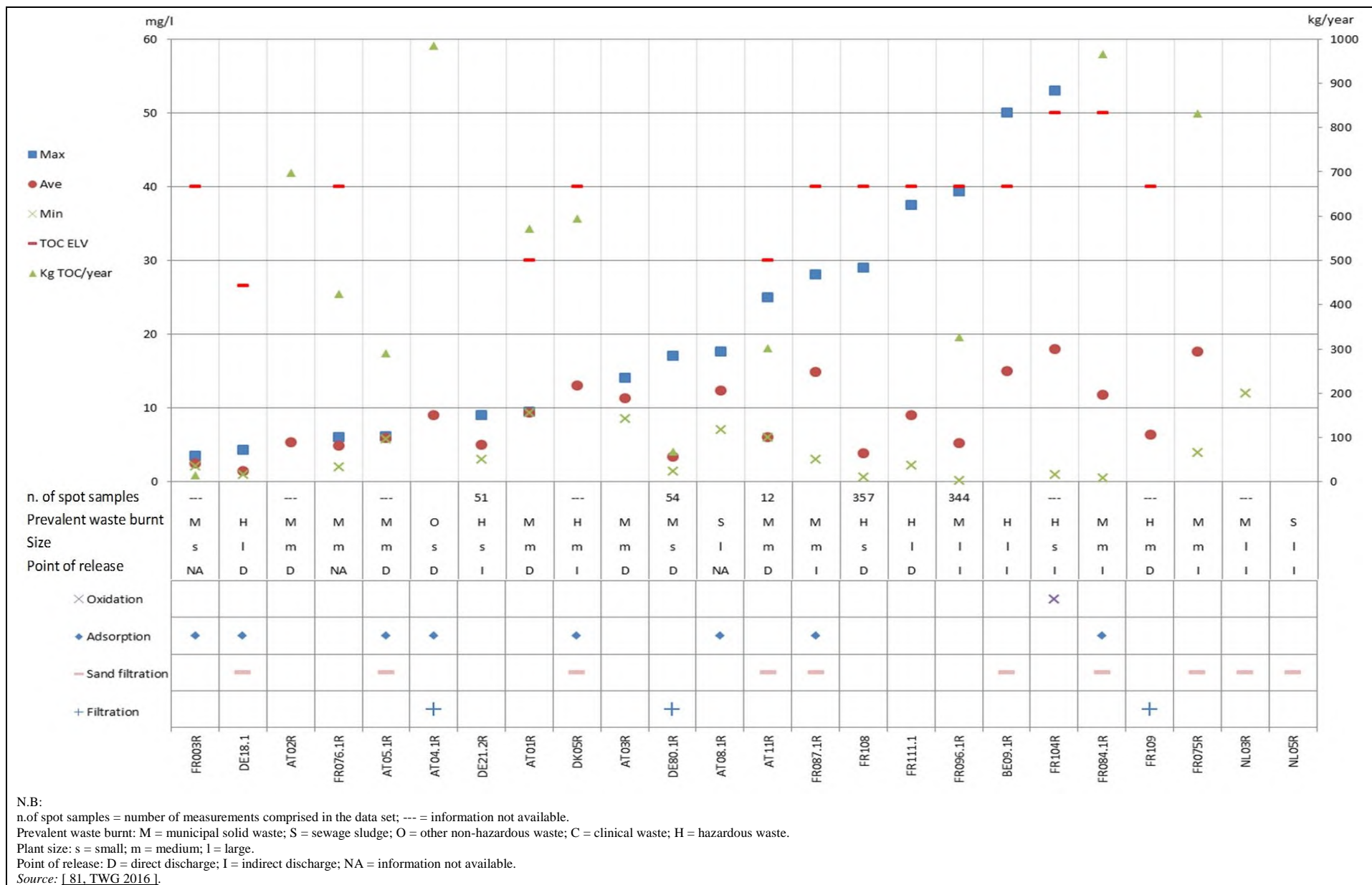

Figure 3.80: Total organic carbon emissions to water and abatement techniques applied

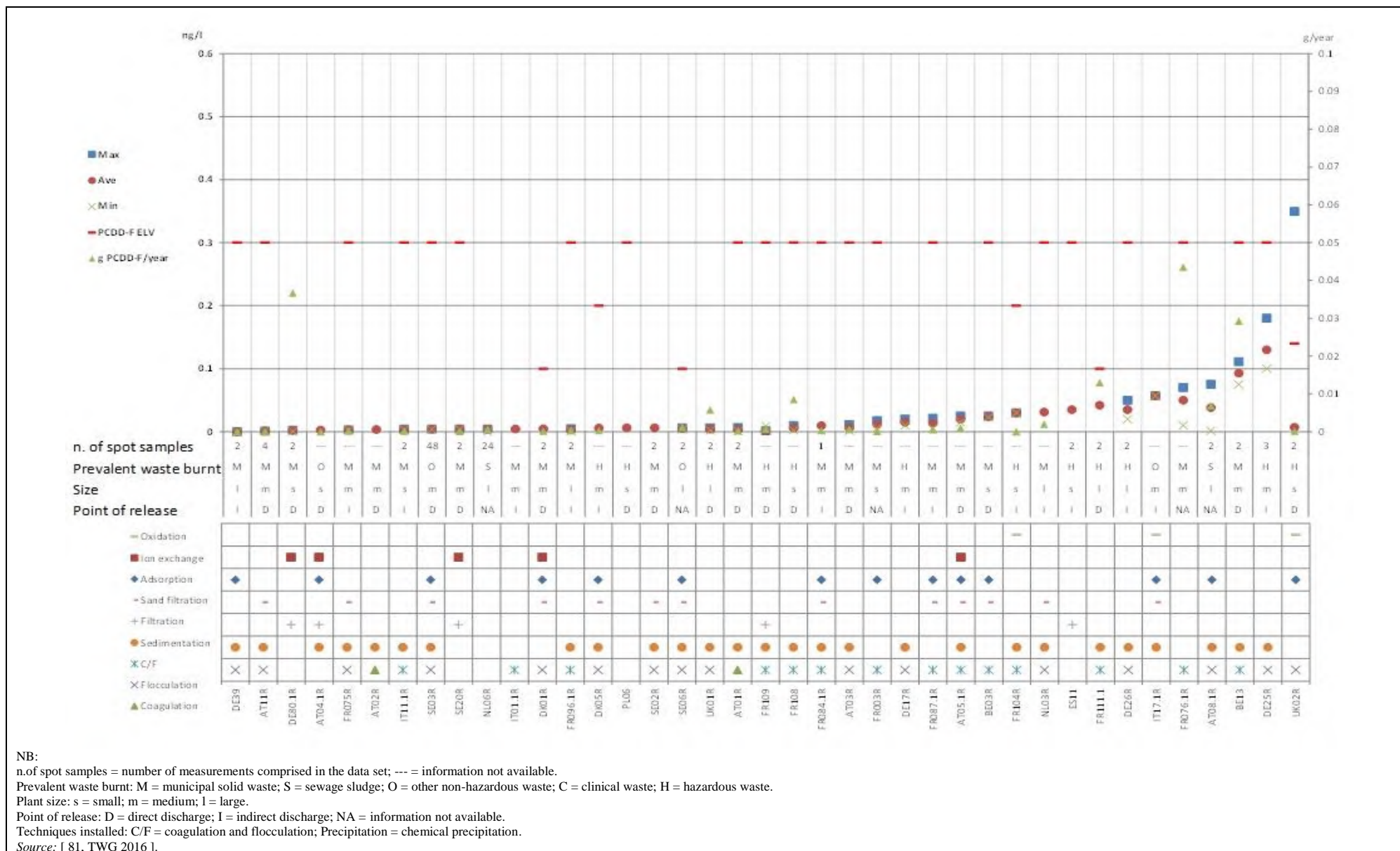

Figure 3.81: PCDD/F emissions to water and abatement techniques applied

3.4 Solid residues

3.4.1 Mass streams of solid residues

In Table 3.13, some typical data on residues from waste incineration plants are summarised.

Table 3.13: Typical data on the quantities of residues arising from waste incineration plants

Types of waste	Specific amount (dry) (kg/t of waste)
Bottom ash/slag	150–350
Boiler ash	20–40 ⁽¹⁾
Fly ash from: Wet FGC Semi-wet FGC Dry FGC	15–40 20–50 15–60
Sludge from waste water treatment	1–15
⁽¹⁾ Fluidised bed furnaces produce a higher amount of boiler ash. Source: [81, TWG 2016]	

MSWI plants generate between 150 kg and 350 kg bottom ashes per tonne of waste treated. This figure includes the grate siftings. The mass flow of siftings depends on the type of grate and its time of operation. The siftings increase the amount of unburned matter in the bottom ashes and can contribute to leaching of copper. Concerning the recovery of materials from the bottom ashes, ferrous and non-ferrous materials (e.g. aluminium) are commonly separated. [74, TWG 2004]

The generation of boiler ash depends on the type of boiler and on the amount of dust originally released from the furnace. Limited data are available on boiler ash production in fluidised bed furnaces, but they show a clear tendency for this type of furnace to produce a higher level of boiler ash.

3.4.2 Solid residues' composition and leachability

Combustion trials have demonstrated that an increase in the heating value of the waste feed and the resulting higher bed temperatures improve the burnout of bottom ash. [38, Vehlow 2002]

Figure 3.82 and Figure 3.83 show data on the maximum percentage of TOC in the bottom ash/slag coming from the incineration of waste measured in 2014, while Figure 3.84 and Figure 3.85 show the maximum percentage of loss on ignition (LOI) measured in 2014. The figures also show the prevalent type of waste burnt, the plant size, the type of furnace used and whether the waste residue has been classified by the operator as slag, bottom ash, or fluidised bed combustion ash.

The information gathered through questionnaires shows that lower values of TOC content and LOI are reported by the majority of fluidised bed incinerators and by rotary kilns when operated in slagging mode.

TOC determination in accordance with the standard EN 13137 also detects elementary carbon as TOC, which does not cause any problems on landfills. The TOC of bottom ashes comprises mainly elementary carbon, but, to a certain extent, organic compounds are also found (e.g. from sifting of plastics). These cover the spectrum from short-chain compounds up to low volatile species such as PAHs or PCDD/F.

Concentrations of organic compounds in the various solid residues are reported in Table 3.14, Table 3.15 and Table 3.16. In Table 3.15, some higher PCDD/F values in bottom ashes/slags

may be due to the mixing of boiler ashes with these residues before landfilling. Typically, PCDD/F levels are below 10 ng/I-TEQ/kg in bottom ashes that are not mixed with other types of incineration residues. [7, TWG 2017]

Table 3.14: Concentration of organic compounds in the solid residues from the flue-gas cleaning system

Plant code	Prevalent waste	Furnace type	FGC system	Residue description	PAHs (mg/kg)	PCBs (mg/kg)	PCDD/F (ng I-TEQ/kg)
AT08.1	S	r fb	Wet	Boiler ash	NA	NA	186
AT08.2	M	fb	Wet	Boiler ash	NA	NA	0.14
DE26	H	r	Wet	Boiler ash	NA	NA	3.4–9.5
DE76	O	g	Dry	Boiler ash	NA	NA	41
DK05	H	r	Wet	Boiler ash	NA	NA	17
FI01	M	g	Wet	Boiler ash	NA	< 0.021	150–180
IT01	M	g	Wet	Boiler ash	NA	NA	22
IT13	O	g	Dry	Boiler ash	0.68	0.011	285.1
IT14	M	g	Dry	Boiler ash	< 0.5	NA	63–190
IT15	M	g	Dry	Boiler ash	< 0.5	NA	0.11–0.17
IT16R	O	fb	Wet	Boiler ash	1.98–327	0.0093–0.01	1 360–41 400
IT17	O	g	Wet	Boiler ash	0.5	0.002–0.0024	0.35–0.4
IT18	M	g	Dry	Boiler ash	< 1	0.00003	1524
IT22	O	g	Dry	Boiler ash	< 0.5	NA	0.377
IT23	M	g	Dry	Boiler ash	NA	0.01	1 200
DE67	M	g	Semi	Catalyst	NA	NA	231
UK08	M	g	Dry	Catalyst	NA	0.022–0.357	176.3–328.5
AT02	M	g	Wet	Fly ash	NA	NA	440
DE25	H	r	Wet	Fly ash	NA	NA	205
DE26	H	r	Wet	Fly ash	NA	NA	50.1–63.4
DE29	H	r	Wet	Fly ash	NA	NA	90
DE39	M	g	Wet	Fly ash	NA	NA	1 037
DE51	O	g	Wet	Fly ash	NA	NA	114
DE56	M	g	Dry	Fly ash	NA	NA	151
DE74	O	g	Wet	Fly ash	NA	NA	2 500
DE76	O	g	Dry	Fly ash	NA	NA	224
DE80	M	g	Wet	Fly ash	0.54	NA	427
DE86	M	g	Wet	Fly ash	< 0.05	NA	487
FI01	M	g	Wet	Fly ash	NA	< 0.021	250–700
IT02	M	g	Dry	Fly ash	0–0.2	0–0.1	0.0004–0.001
IT11	M	g	Wet	Fly ash	< 2	< 5	0.12–0.04
UK09.1	M	g	Semi	Fly ash	NA	NA	21.6–346
UK09.2	M	g	Semi	Fly ash	NA	NA	21.9–57.4
UK09.3	M	g	Semi	Fly ash	NA	NA	20.2–60.4
UK14	C	o	Dry	Fly ash	NA	13.8–51 (ng/kg)	3671–7633

NB: NA: Information not available

Prevalent type of waste incinerated: M = MSW; O = ONHW; S = SS; H = HW; C = CW.

Furnace type: g = grate; fb = fluidised bed; r = rotary kiln; o = other.

Source: [81, TWG 2016]

Table 3.15: Concentration of organic compounds in the bottom ash/slag

Plant code	Prevalent waste	Furnace type	FGC system	PAHs (mg/kg)	PCBs (mg/kg)	PCDD/F (ng I-TEQ/kg)
AT02	M	g	Wet	NA	< 0.93	2.73
AT08.1	S	r fb	Wet	0.52	< 0.64	0.82
AT08.2	M	fb	Wet	NA	NA	21.1
DE15	S	fb	Wet	NA	< 0.01	15–23
DE16	S	fb	Wet	< 0.1	NA	57–55
DE23	H	r	Wet	0.2	< 0.1	< 5
DE25	H	r	Wet	NA	NA	79.3
DE29	H	r	Wet	< 1	< 0.1	0.01–46
DE30	H	r	Wet	0–60	NA	10–1 000
DE31	H	g	Semi	6.2 POPs	NA	< 0.02
DE39	M	g	Wet	2.7–12.5	NA	n/a
DE55	M	g	Wet	NA	NA	478.3
DE56	M	g	Dry	NA	NA	0.6–9.3
DE69	M	g	Dry	NA	> 1	NA
DE74	O	g	Wet	NA	NA	10.7
DE80	M	g	Wet	NA	NA	13.8
DE86	M	g	Wet	0.74	NA	4.71
DK05	H	r	Wet	NA	NA	58
FI01	M	g	Wet	NA	< 0.021	7.6–13
FR108	H	r f	Wet	NA	3519	NA
IT01	M	g	Wet	NA	NA	1.1–54
IT02	M	g	Dry	0.1	0.0000001	5.92– 41.3
IT11	M	g	Wet	< 2	< 5	< 0.02
IT13	O	g	Dry	0.40	1.40	6.0
IT14	M	g	Dry	< 0.5	NA	1.1–8.6
IT15	M	g	Dry	< 0.5	NA	0.0014–0.003
IT16	O	fb	Wet	< 0.5	< 0.01	1.3–6.78
IT17	O	g	Wet	0.5–0.96	0.0096–0.028	0.0035–0.008
IT18	M	g	Dry	< 1	< 1	1–4
IT22	O	g	Dry	< 5	NA	3.6
IT23	M	g	Dry	NA	0.01	9.3
UK07.1	M	fb	Dry	NA	0.000017	443
UK07.1	M	fb	Dry	NA	0.0000001–0.00000086	1.1–6.6
UK07.2	M	fb	Dry	NA	0.000011	340
UK07.3	M	fb	Dry	NA	0.000016	494
UK08	M	g	Dry	1.15–1.39	0.003–0.197	4.14–8.39
UK09.1	M	g	Semi	NA	NA	2.46–6.1
UK09.2	M	g	Semi	NA	NA	1.5–10.6
UK09.3	M	g	Semi	NA	NA	2.39–13.4
UK14	C	o	Dry	NA	0.22–2.5 ng/kg	13.7–53.9

NB: NA: Information not available

Prevalent type of waste incinerated: M = MSW; O = ONHW; S = SS; H = HW; C = CW.

Furnace type: g = grate; fb = fluidised bed; r = rotary kiln; o = other.

Source: [81, TWG 2016]

Table 3.16: Concentration of organic compounds in the solid residues from the waste water treatment plant

Plant code	Prevalent waste	Furnace type	Description	PAHs (mg/kg)	PCBs (mg/kg)	PCDD/F (ng I-TEQ/kg)
DE30	H	r	Gypsum	0–0.6	below LOD	150–170
DE51	O	g	Gypsum	NA	NA	11.2
DE74	O	g	Gypsum	NA	NA	266 550
DE86	M	g	Gypsum	0.82	NA	9.29
DE25	H	r	Sludge	NA	NA	11 971
DE39	M	g	Sludge	NA	NA	592
DE80	M	g	Sludge	NA	NA	14
FR108	H	r f	Sludge	NA	0.186	NA
IT02	M	g	Sludge	0.1	0.000002	6.73E-5 – 4.16E-6
IT11	M	g	Sludge	< 1	< 5	< 0.02–0.1
IT17	O	g	Sludge	0.5	0.0072–0.022	0.098–0.14
NB: NA: Information not available Prevalent type of waste incinerated: M = MSW; O = ONHW; S = SS; H = HW. Furnace type: g = grate; fb = fluidised bed; r = rotary kiln. Source: [81, TWG 2016]						

Bottom ashes from the incineration of MSW

The mineral fraction, scrap metals and the non-incinerated fraction are the main components of bottom ash from MSW incineration. The mineral fraction mainly contains silicates, alkaline earth and salts.

The relative partitioning of elements into bottom ash depends mainly on the composition of the MSW fed to the incinerator, the volatility of the elements it contains, the type of incinerator and grate system applied and the operation of the combustion system. [4, IAWG 1997]

The mass and volume reduction of waste incineration causes an enrichment of the non-volatile metals in the bottom ashes compared to their concentration in the waste feed. Some metals, e.g. arsenic, cadmium or mercury, are, to a great extent, volatilised out of the fuel bed. It is evident that, with the exception of the mainly lithophilic copper, all selected metals are highly enriched in filter dust.

The scrap metal components are ferrous (mainly ferrous scrap and stainless steel) and non-ferrous metals (mainly aluminium, brass and copper) (see Table 3.17).

Table 3.17: Main components of raw bottom ash

Categories	Percentage by weight (mass-%)
Mineral fraction	85–90
Non-incinerated fraction	< 3
Ferrous metal scrap	< 5–10
Non-ferrous metal scrap	0.5–2
Source: [82, Germany 2014]	

As for other materials, when assessing the risks associated with bottom ashes, the important parameter is not only the intrinsic presence or absence of substances and their chemical and physical form, but also their potential release depending on the nature of the environment where the material will be used [7, TWG 2017]. Table 3.18 reports the bottom ash composition.

Table 3.18: Chemical composition of bottom ash from the incineration of MSW

Values in wt.-% Parameter	Bottom ash		
	Min.	Average	Max.
SiO ₂	42.91	49.2	64.84
Fe ₂ O ₃ *	9.74	12	13.71
CaO*	10.45	15.3	21.77
K ₂ O*	0.83	1.05	1.36
TiO ₂ *	0.65	1.03	1.33
MnO*	0.06	0.14	0.22
Al ₂ O ₃ *	6.58	8.5	10.79
P ₂ O ₅ *	0.55	0.91	1.49
MgO*	1.79	2.69	3.4
Na ₂ O*	1.86	4.3	5.81
CO ₂	2.56	5.91	10.96
Sulphates	2.5	15.3	28.3
Chloride	1.3	3.01	7
Cr (ppm)	174	648	1035
Ni (ppm)	55	215	316
Cu (ppm)	935	2 151	640
Zn (ppm)	1 200	2 383	4001
Pb (ppm)	497	1 655	3245
NB: * These values are calculated based on X-ray fluorescence analysis. Source: [82, Germany 2014]			

Usually two different types of bottom ash analysis are performed. The first method analyses the available mobile compounds (eluate analysis (i.e. leachate)) of the bottom ash fraction. The second method analyses the complete compounds of the bottom ash (solids analysis). The use of the methods is determined by the way that the mineral fraction is used. However, the eluate analysis is more important when assessing the possibility of material recovery, [75, FEAD 2014] because almost all regulations for the disposal or utilisation of waste products are based on standardised leaching tests.

Table 3.19 gives the leaching values for untreated bottom ashes as reported in the WI BREF review data collection.

Table 3.19: Leaching properties of untreated bottom ash

Compound	Minimum leaching value (mg/kg)	Maximum leaching value (mg/kg)
(SO ₄) ²⁻	200	10 000
As	0.00045	28
Ba	0.05	38
Br ⁻	7.6	NA
Cd	0.002	6.7
Cl ⁻	5	10 000
CN ⁻ (free)	0.01	NA
CN ⁻ (total)	0.048	NA
Co	0.1	0.2
Cr tot	0.004	1.24
Cu	0.005	20
F ⁻	0.2	1300
Hg	0.0002	0.1
Mo	0.01	3.3
Ni	0.005	0.3
Pb	0.005	21
Sb	0.005	1.2
Se	0.001	0.13
Sn	0.04	NA
V	0.01	0.2
Zn	0.01	6.7
NB: Ratio L/S = 10 l/kg. Source: [81, TWG 2016]		

The following substances may be considered important for MSW bottom ashes: copper, zinc, antimony, molybdenum, chloride and sulphate. Treatment techniques aim to reduce the leachability of these substances.

Residues from the incineration of hazardous waste

Residues from hazardous waste incineration, due to the type and composition of the incinerated waste, differ from those of non-hazardous waste incineration plants because hazardous wastes have a higher concentration of inorganic pollutants (some of which may not be present at all in non-hazardous waste) which are transferred to the residues. However, the following differences can be observed:

- In the case of ash and slag: the incineration of hazardous waste in drums is usually performed at temperatures higher than those used for municipal waste incineration. This can result in different metal partitioning.
- Owing to variations in waste type and content, the specific amount of bottom ash can be subject to variations much greater than those in municipal waste incineration plants. These variations can be seen within the same plant according to the wastes fed, as well as between different plants and technologies.
- In the case of filter dust/FGC residues, as the concentration of metals is normally higher in hazardous waste, the solid residues produced may also contain considerably higher concentrations of metals.

Table 3.20 provides an overview of the parameters measured by some plants incinerating hazardous waste to ensure the effective destruction of the hazardous components of the waste and that can be related to their destruction efficiency.

Table 3.20: Methods and parameters used by waste incineration plants to ensure the efficient destruction of hazardous waste compounds

Plant and furnace type		Tonnes of Waste burnt in 2014	Measured parameters related to the destruction of hazardous compounds in the waste	Method	Other parameters used to measure the quality of the bottom ash/slag generated and the method used
DE15	fb	162 500	CO emission after incineration	Laser method	Not measured
DE18	r	105 000	TOC	Not reported	Not measured
DE20	f	33 700	Water content/dry residue; TOC; LOI	105 °C; DIN EN 13137; DIN EN 15169	Some graphite material is burned. As the 'TOC' value in the slag obtained by the standard method includes the inorganic carbon, TIC is measured as well if the TOC limit is reached. The difference is the 'real' TOC.
DE21	f	12 696	Temperature at the end of the furnace, oxygen in the furnace, minimum combustion air flow, flame detection and the AMS for air emissions	Thermocouples, infrared, flow meters, etc.	Not measured
DE23	r	55 223	None	Not applicable	Eluate with DIN 38404-C5/ DIN 10523
DE25	r	56 478	None	Not applicable	Leaching test

DE26	r	137 966	CO emission after incineration	Laser method	Measurement of metal content from mixed samples 12 times a year
DE28	r	55 006	Ash content	Not reported	Not measured
DE29	r	117 629	None	Not applicable	Extractable lipophilic matter in original substance; method: German LAGA Guideline KW/04 (2009); result: 0.044 % (yearly average; 21 measurements)
DE38	g	580 746	None	Not applicable	Leaching test
DE39	g	302 749	As, Cd, Cr tot, Cu, Hg, Ni, Pb, Zn, PAHs	ISO11885-E22, ISO16772, ISO18287	Not measured
DE44	g	494 815	Not measured	Not applicable	Due to LAGA – rule with catalogue of critical value, LAGA 20 = Z 2
DE52	g	187 311	None	Not applicable	EOX, heavy metals, dioxins
DE55	g	385 951	Ar, Pb, Cd, Cr, Cu, Ni, Hg, Zn, Cl, SO ₄	DIN EN ISO 17294-2/ DIN EN ISO 12846/ DIN 38414-4/ DIN EN ISO 10304-1/ DIN ISO 18287	Not measured
DE56	g	219 329	None	Not applicable	Sorted amount with DIN ISO 11464; dry residue with DIN ISO 11465; LOI with DIN 18128; EOX with DIN 38414-S17; cadmium, arsenic, lead, copper, nickel, chromium and zinc with DIN EN ISO 11885; mercury with DIN EN 1483; PAH with DIN ISO 13877
DE60	g	364 133	None	Not applicable	EOX (DIN 38414 s17); PAH (DIN ISO 13877)
ES11	r	44 516	Continuous/periodic monitoring emissions control	Automatic measurement system	Every 3 months: metals content in bottom ashes. TOC and LOI
FI01	g r	317 095	None	Not applicable	TOC, PCDD/F, PCB, XRF
FR106	f	59 051	None	Not applicable	Ni and Zn
FR108	r f	32 930	Intrinsic PCB content	Not reported	Analysis of key parameters in the slags; TOC and LOI
FR110	r	126 468	TOC	TOC meter	Hourly visual inspection; TOC tested at 870 °C measuring the CO produced; Visual control at the kiln outlet with endoscope; Choice of nozzles positioning (low calorific value/high calorific value) to avoid or make a thermal barrier; Variation of the kiln rotation speed)

FR111	r	196 055	LOI and metals in the solid residues	EN 12457-2	Leaching test
NL05	fb	360 100	None	Not applicable	Phosphorus
NO01	g	185 980	Not reported	Not reported	Not measured
NO02	g	141 896	Flue-gas measuring	Not reported	A basic characterisation is performed every year on bottom ashes that have been sorted (metals sorted out)
PL03	r	28 267	TOC	EN13137	LOI method EN15169
PL05	fb	15 673	None	Not applicable	Measured parameters specified in Annex 1 – 3 of National Law (criteria and procedures for allowing waste to landfilling of waste like in Landfill Directive)
SE03	g	176 487	Metals, TOC, etc.	Tests are carried out when new HW are incinerated but not on a routine basis	Not measured
SE21	g r	153 249	PCBs, PAHs	Gas chromatography	X-ray fluorescence (XRF) scan of the slag and all types of ash
UK02	r	37 344	LOI	BS EN 15169:2007	Not reported
UK08	g	261 257	Not measured	Not applicable	pH, Alkalinity Reserve and metals
NB: g = grate furnace; fb = fluidised bed furnace; r = rotary kiln; f = other furnace. Source: [81, TWG 2016]					

Typical leaching values for bottom ashes from hazardous waste incineration are given in Table 3.21.

Table 3.21: Typical leaching values of bottom ash from the incineration in hazardous waste incineration plants

Compound	Minimum (mg/kg)	Maximum (mg/kg)
As	< 0.01	16
Ba	< 0.01	14.4
Cd	< 0.01	2.1
Co	0.03	< 0.1
Cr ^{tot}	< 0.01	30
Cr ^{VI}	< 0.01	10
Cu	<0.01	2.15
Hg	< 0.002	1
Mn	0.008	0.68
Mo	0.01	21
Ni	<0.01	5
Pb	<0.01	13
Sb	< 0.005	4
Se	< 0.01	1
Tl	< 0.001	< 0.35
V	0.005	0.1
Zn	< 0.02	3.2
Chloride	< 1	4 700
Fluoride	< 0.1	15
Sulphate	2	3 600
Phenol Index	< 0.01	10
DOC	< 1	130
TDS	< 50	18 000
TOC	0.09	55
BTEX	0	< 0.15
PCBs 7	< 0.02	< 0.05
Mineral oil	NA	< 100
PAHs	< 0.05	6.2
NB: Ratio L/S = 10 l/kg. Source: [81, TWG 2016]		

Residues from the incineration of sewage sludge

The chemical structure of sewage sludge ash is influenced considerably by the weather, in particular the amount of rain. In the case of rainy weather, larger amounts of clay and fine sand enter the sewerage system, pass the grit chamber, are precipitated in the preliminary sedimentation basin and reach the sludge incineration with the primary sludge. As a result, the silicate content of the ash is increased considerably, and the contents of other components are diluted in periods of rainy weather.

In addition, the type of catchment and the treatments carried out have a great effect on the sludge quality. Areas with a large number of heavy industrial connections may result in higher concentrations of heavy metals being fed to the incinerator; these substances may then accumulate in bottom and fly ashes. Rural areas, with little industry, may give rise to less polluted sludge and hence a lower contamination of incinerator residues.

Another major influence is the nature of the treatment (and therefore of the reagents: mineral, polymeric, etc.) that is applied in order to purify the waste water.

[74, TWG 2004]

Information on the content of phosphorus and of some hazardous organic substances in the solid residues coming from the incineration of waste is reported in the Table 3.22 below.

Table 3.22: Content of phosphorus, PAHs, PCBs and PCDD/F in the solid residues coming from the incineration of sewage sludge

Plant code	Prevalent waste	Furnace type	FGC type	Residue type	P (mg/kg)	PAHs (mg/kg)	PCBs (mg/kg)	PCDD/F (ng I-TEQ/kg)
DE15	S	fb	Wet	Bottom ash/slag	29 200–38 700	NA	< 0.01	15–23
DE16	S	fb	Wet	Bottom ash/slag	28 000–46 000	< 0.1	Not determined	57–55
DE26	H	r	Wet	Boiler ash	14 800–35 700	NA	NA	3.4–9.5
DE26	H	r	Wet	Bottom ash/slag	2 700–5 500	NA	NA	NA
DE26	H	r	Wet	Fly ash	19 000–29 800	NA	NA	50.1–63.4
DE70	M	g	Dry	Bottom ash/slag	70	NA	NA	NA
DE73	M	g	Semi	Bottom ash/slag	< 0.1–1.1	NA	NA	NA
DE73	M	g	Semi	Fly ash	< 0.1–0.66	NA	NA	NA
DE74	O	g	Wet	Bottom ash/slag	2 300	NA	NA	NA
DE74	O	g	Wet	Fly ash	5 700	NA	NA	NA
DE74	O	g	Wet	Gypsum	230	NA	NA	NA
DE87	S	fb	Wet	Bottom ash/slag	90 000	NA	NA	NA
NL05	S	fb	Wet	Bottom ash/slag	113 000	NA	NA	0
NL05	S	fb	Wet	Fly ash	1 500	NA	NA	3
NL06	S	fb	Wet	Bottom ash/slag	87 000	NA	NA	NA
SE20	M	g	Wet	Boiler ash	2 870	NA	NA	NA

NB: Prevalent type of waste incinerated: M = MSW; O = ONHW; S = SS; H = HW.
Furnace type: g = grate; fb = fluidised bed; r = rotary kiln.
Source: [81, TWG 2016]

Issues with other waste types

Clinical waste issues are that:

- burnout needs to be thorough to ensure the destruction of infective agents;
- hypodermic needles and other sharp materials in the bottom ash may give rise to additional handling risks.

Quality of solid residue from fluidised beds

Because of differences in the process, the waste properties and the combustion temperatures, the quality of ashes is very different to that of ashes of grate incinerators. Generally, the lower (but more even) operating temperatures, the nature of the fuel and the process in fluidised beds mean that:

- a greater proportion of volatile metals remain in the bottom ash – consequently, concentrations of heavy metals in the flue-gas residues are reduced; however, sometimes there are problems with CrVI levels in the soluble part of the bottom ash;
- the degree of vitrification of the ash may be reduced;
- burnout may be improved.

When recovered fuel is produced for fluidised bed boilers, the ash content is usually 1–10 %, and with construction and demolition waste it is normally 1–7 %. [33, Finland 2002]. Household waste burnt in rotating fluidised bed incinerators has an ash content of up to 30 % and up to 15 % in the case of RDF.

The majority of solid residue from fluidised bed incineration is fly ash, which, according to conditions and applied fluidised bed technology, can form up to 90 % of the total ash residue. The bottom ash is also mixed with fluidised bed material (e.g. sand, additives for desulphurisation). When waste or RDF is burnt in a rotating fluidised bed, the ratio of bottom ash to fly ash is about 50:50.

When waste originating from construction and demolition is used, a small increase can be found in the heavy metal content of both types of ash compared to wood combustion. When the recovered fuel is made of household waste, there is a greater increase in heavy metals. The amount of the increase depends on the type of household waste used. If all the household waste is combusted, the increase is high. If source separation is used, and only combustible packaging material is combusted, the increase of heavy metals is less. Recovered fuels made of industrial wastes can be very variable and therefore result in a wide range of ash qualities.

Table 3.23: Leaching values of bottom ash from fluidised bed furnaces

Compound (unit)	Plant code and prevalent waste burned								
	AT08.1	AT08.2	BE08	IT16	PL01	PL05	UK07	UK17	UK18
	S	M	O	O	S	S	M	O	O
As (mg/kg)	< 0.01	< 0.01	0	0.001	1.72	0.042– 6.09	< 0.008	< 0.02– 0.142	< 0.02– < 0.03
Ba (mg/kg)	22	2.1	1.6	0.307– .784	1	0.307– 0.428	1.52	1–10.2	1.49–2.84
Cd (mg/kg)	0.019	0.02	0	0.005	0.13	< 0.005	< 0.001	< 0.01	< 0.003– < 0.01
Co (mg/kg)	< 0.5	< 0.5	0	NA	NA	NA	< 0.006	< 0.1	< 0.1–< 0.2
Cr tot (mg/kg)	< 0.3	< 0.3	1.4	0.042– 0.081	0.1	< 0.030	2.26	0.028– 0.69	0.2–0.69
Cr ^{VI} (mg/kg)	< 0.3	< 0.3	0.6	NA	NA	NA	NA	0.37– 0.6	NA
Cu (mg/kg)	< 0.5	< 0.5	0.47	0.005– 0.097	0.28	0.059– < 0.040	0.13	< 0.1– 0.44	< 0.1–< 0.2
Hg (mg/kg)	< 0.001	< 0.001	0	0.0005	0.005	< 0.005– < 0.005	< 0.000 1	< 0.000 2	< 0.0002– < 0.0003
Mn (mg/kg)	< 0.1	< 0.1	0	NA	NA	NA	< 0.04	< 0.1	< 0.1–< 0.2
Mo (mg/kg)	22.3	0.3	2.19	0.009– 0.019	3.98	< 0.040– 11	0.4	0.028– 0.12	0.32–0.85
Ni (mg/kg)	< 0.3	< 0.3	0	0.005	0.25	< 0.040	< 0.01	< 0.1	< 0.1–< 0.2
Pb (mg/kg)	1.7	< 0.3	71.9	0.005– 0.011	0.31	< 0.100	0.2	0.09– 4.3	0.016–1.27
Sb (mg/kg)	< 0.3	0.4	0	0.024– 0.157	0.099	< 0.010– < 0.50	< 0.17	0.065– 0.25	0.12–0.31
Se (mg/kg)	< 0.1	< 0.1	0	0.001	3.69	0.015– 21.4	< 0.01	< 0.02	< 0.02– < 0.03
Tl (mg/kg)	< 0.5	< 0.5	0	NA	NA	NA	< 0.01	0.024– 0.87	< 1–< 2
V (mg/kg)	0.15	0.2	0	NA	NA	NA	0.24	0.012– 0.19	< 0.1–< 0.2
Zn (mg/kg)	0.6	< 0.1	0.4	0.05	1	< 0.050	0.53	< 0.1– 27.3	< 0.2–0.2
Chloride (mg/kg)	3 240	909	1 915	81–122	6 568	< 50– 26 900	1210	12–29.2	263–707
Fluoride (mg/kg)	19	3	5	NA	2251	< 1.0– 1 269	< 0.96	0.88– 1.16	0.1–1.52
Sulphate (mg/kg)	1 600	13 000	10 024	11232	60 000	186– 296 350	1610	30.4–64	206–853
Phenol Index (mg/kg)	1.1	< 0.1	NA	NA	NA	NA	NA	< 0.1	NA
DOC (mg/kg)	NA	NA	NA	20	1366	28.9–36.2	NA	1.68–9	NA
TDS (mg/kg)	NA	NA	NA	1620– 4270	596 352	1 440– 722 220	3030	760– 3 468	5 700– 7 500
TOC (mg/kg)	302	25	36.9	NA	0.43	NA	NA	NA	5.2–10.6
BTEX (mg/kg)	NA	NA	NA	NA	NA	NA	NA	NA	NA
PCBs 7 (mg/kg)	NA	NA	NA	NA	NA	NA	0.0001	NA	NA
Mineral oil (mg/kg)	1	< 1	NA	NA	NA	NA	NA	NA	NA
PAHs (mg/kg)	NA	NA	NA	NA	NA	NA	< 2.4	NA	NA
PCDD/F (mg/kg)	NA	NA	NA	NA	NA	NA	0.00000 198	NA	NA

NB: Prevalent type of waste incinerated: M = MSW; O = ONHW; S = SS.

Ratio L/S = 10 l/kg.

NA = not available.

Source: [81, TWG 2016]

3.4.3 Incineration bottom ash/slag treatment

According to the data gathered, all plants in Europe treat the incineration bottom ash/slag with ferromagnetic separation to recover iron and most use eddy current separation to recover the non-ferrous metals.

Table 3.24 reports the main features of the incineration slag and/or bottom ash treatment plants that participated in the 2016 data collection.

Table 3.24: Incineration bottom ash treatment plants' characteristics

Plant	Capacity (t/year)	Throughput (t/h)	Within WI plant	Treatment type	Process used
AT.B-01	40 000	90	No	Dry, Wet, Wash	M,F,E,Dw,SS
BE.B-01	100 000	25	Yes	Dry	F,E,A,B,SS
BE.B-02	NA	75	Yes	Wet	M,F,E,S,Dw,SS
CZ.B-01	120 000	50	Yes	Wet	M,F,E,
DE.B-01	180 000	100	No	Dry	M,F,E,A,SS
DE.B-02	400 000	90	NA	Wet, Dry, Wash	M,F,E,A,Dw,SS
DE.B-03	300 000	120	No	Wet	M,F,E,SS
DE.B-04	600 000	130	No	Dry	M,F,E,I,N,O,A,SS
DE.B-05	340 000	120	No	Dry	M,F,E,A,SS
DE.B-06	216 000	100	No	Dry	M,F,E,A,SS
DE.B-07	450 000	120	No	Dry	M,F,E,A,SS
DE.B-08	250 000	80	No	Dry	M,F,E,I,A,SS
DE.B-09	70 000	37	Yes	Dry	M,F,E,SS
DE.B-10	90 000	100	Yes	Dry, Wash	M,F,E,
DE.B-11	90 000	100	Yes	Dry, Wash	M,F,E,A
DE.B-12	79 000	55	Yes	Dry	F,E,A,SS
DE.B-13	140 000	100	Yes	Wet	M,F,E,I,A,B,SS
DE.B-14	NA	NA	Yes	Dry	M,F,E,B,SS
DK.B-01	125 000	100	No	Wet	M,F,E,I,A,SS
DK.B-02	750 000	120	No	Wet	M,F,E,I,A,SS
DK.B-03	180 000	90	No	Wet	M,F,E,A,SS
ES.B-01	200 000	120	Yes	Dry, Wash	M,F,E,A,SS
FR.B-01	5 500	1.2	Yes	Dry	F,E,SS
FR.B-02	12 000	3	Yes	Dry	F,E,SS
FR.B-03	90 000	NA	Yes	Dry	F,E,A,SS
FR.B-04	87 000	100	Yes	Dry	M,F,E,SS
FR.B-05	54 250	80	Yes	Dry	F,E,A,SS
FR.B-06	200 000	100	No	Dry	M,F,E,A,SS
FR.B-07	120 000	92	No	Dry	M,F,E,A,SS
FR.B-08	100 000	40	No	Dry	M,F,E,SS
FR.B-09	7 000	0.84	Yes	Dry	F,SS
FR.B-10	20 000	35	No	Dry	F,E,SS
IT.B-01	250 000	110	No	Dry	M,F,E,A,SS
IT.B-02	620 000	160	No	Wet, Dry, Wash	M,F,E,I,A,S,Dw,Dd,SS
NL.B-01	180 000	100	Yes	Dry	F,E,A,B,SS
NL.B-02	320 000	130	No	Dry	F,E,A,B,SS
NL.B-03	700 000	200	No	Dry	M,F,E,A,B,SS
PT.B-01	200 000	60	No	Dry	M,F,E,A,SS
PT.B-02	NA	NA	Yes	Dry	F
SE.B-01	87 000	1000	Yes	Dry	F,E,SS
SE.B-02	129 905	40	No	Dry	F,E,A,SS
SE.B-03	100 000	100	No	Dry	M,F,E,I,SS
UK.B-01	200 000	120	No	Dry	F,E,A,B,SS

NB: NA = not available; dry = dry treatment system; wash = bottom ash washing; wet = wet treatment system; A = wind sifter / air/aerulic separation; B = ballistic separation; Dd = dry density separation; Dw = wet density separation; E = eddy current separation; F = ferromagnetic separation; I = induction all-metal separation; M = manual sorting; N = near-infrared separation; O = optical separation other than NIS; S = sink-float separation; SS = screening/sieving.
Source: [8], TWG 2016]

3.4.3.1 Mass streams

The quantity of ferrous and non-ferrous metals recovered from the incineration bottom ash/slag depends on the composition of the incinerated waste and on the process applied to extract this component from the IBA. Table 3.25 and Table 3.26 show the quantity of bottom ash/slag treated in 2014 by the bottom ash treatment plants that participated in the 2016 data collection, and the percentage of ferrous and non-ferrous metals recovered.

Table 3.25: Plants treating slag/bottom ash with European waste code 19 01 12: quantities treated in 2014 and percentages of ferrous and non-ferrous metals recovered

Plant	Quantity treated (t)	Ferrous metals (%)	Non-ferrous metals (%)
AT.B-01	32 546	1.15	1.85
BE.B-01	88 655	NA	NA
BE.B-02	87 813	8	3
CZ.B-01R	59 145	6	0.3
DE.B-01	157 600	5.77	1.46
DE.B-02	276 000	NA	NA
DE.B-03	140 180	10	1
DE.B-04	522 874	4–8	0.20–1
DE.B-05	244 931	7.66	2.613
DE.B-06	141 000	4.8	3.34
DE.B-07	304 000	NA	NA
DE.B-08	46 500	NA	NA
DE.B-09	61 172	8	0.8
DE.B-10	56 476	11.47	1.45
DE.B-11	NA	9	2.9
DE.B-12	79 000	5.06	0.68
DE.B-13	104 015	6.2 ⁽¹⁾	1.06 ⁽¹⁾
DE.B-14	64 262	9.3	0.8
DK.B-01	116 161	6	1.2
DK.B-02	750 000	NA	NA
DK.B-03	11 000	3.6 ⁽¹⁾	1.1 ⁽¹⁾
ES.B-01R	114 376	8.3	0.53
FR.B-01	11 432	NA	NA
FR.B-02	11 216	NA	NA
FR.B-03	96 186	NA	NA
FR.B-04	68 838	NA	NA
FR.B-05	45 717	NA	NA
FR.B-06	127 203	1.1	1.9
FR.B-07	104 469	NA	NA
FR.B-08	80 000	NA	NA
FR.B-09	5 837	NA	NA
FR.B-10	4 810	NA	NA
IT.B-01	132 217	8	2
IT.B-02	301 288	10	1.5
NL.B-01	205 131	6.5	2.3
NL.B-02	240 559	6.2	3
NL.B-03	616 072	4.59	1.86
PT.B-01	112 506	NA	NA
PT.B-02	18 179	2.46	NA
SE.B-01	87 000	4.44	1.89
SE.B-02	129 905	4.4 ⁽¹⁾	1.74 ⁽¹⁾
SE.B-03	99 275	5.4	1.5
UK.B-01	171 196	7	2.3

NB: NA = not available.
⁽¹⁾ estimated value based on calculation
The percentage of ferrous and non-ferrous metals separated from the treated waste is net. It does not take into account the impurities.
Source: [81, TWG 2016]

Table 3.26: Plants treating slag/bottom ash with European waste code 19 01 11* in 2014: quantities treated and percentages of ferrous and non-ferrous metals recovered

Plant	Quantity treated (t)	Ferrous metals (%)	Non-ferrous metals (%)
DE.B-03	73 025	10	1
IT.B-01	39 592.81	8	2
IT.B-02	30 779	10	1.5

NB: The percentage of ferrous and non-ferrous metals separated from the treated waste is net. It does not take into account the impurities.
 Source: [81, TWG 2016]

Table 3.27 gives an overview of the treatment results and of the destinations of the treated bottom ash/slag. Most of it is recovered and reused in road construction or earthworks or sent to landfill.

Table 3.27: Input and output of European incineration bottom ash treatment plants in 2014

Plant	Waste		R/D	Grain size (mm)	Destination						
	Input (t)	Output (t)			RC	L	OS	U	RP	AF	OR
AT.B-01	32 546	31 566	D	0–50	No	Yes	No	No	No	No	No
BE.B-01	88 655	80 711	R	0–20	Yes	No	No	No	No	No	Yes
BE.B-02	87 813	71 580	R/D	< 0.67; 0.67–2; 2–6; 6–50	Yes	Yes	Yes	No	No	No	No
CZ.B-01R	59 145	59 145	R	0–16; 16–42; > 42	No	Yes	No	No	No	No	No
DE.B-01	157 600	130 000	R	0–45	Yes	Yes	Yes	No	No	No	No
DE.B-02	276 000	243 500	R/D	0–0.25; 0.25–45	No	Yes	Yes	No	No	No	No
DE.B-03	140 180 73 025	189 540	R	0–80	No	Yes	No	Yes	No	No	No
DE.B-04	522 874	411 546	R/D	0–55	Yes	Yes	No	No	No	No	No
DE.B-05	244 931	206 822	R	0–32	No	Yes	No	No	No	No	No
DE.B-06	141 000	128 116	R	0–32	Yes	Yes	Yes	No	No	No	No
DE.B-07	304 000	280 000	R	0–32	Yes	No	No	No	No	No	No
DE.B-08	46 500	41 300	R	0–2; 2–8; 8–40	Yes	Yes	Yes	No	No	No	Yes
DE.B-09	61 172	55 745	R	0–32	No	Yes	No	Yes	No	No	No
DE.B-10	56 476	47 294	R	0–32	Yes	No	Yes	No	No	No	No
DE.B-11	NA	79 412	R	0–32	Yes	No	Yes	No	No	No	No
DE.B-12	79 000	64 300	R/D	NA	No	Yes	No	No	No	No	No
DE.B-13	104 015	108 855	R/D	NA	No	Yes	No	No	No	No	No
DE.B-14	64 262	57 814	R/D	0–32; < 32	No	Yes	No	No	No	No	Yes
DK.B-01	116 161	104 540	R	0–50	Yes	No	No	No	No	No	No
DK.B-02	750 000	675 000	R	0–50	Yes	No	No	No	No	No	No
DK.B-03	11 000	30 000	R	0–50	Yes	No	No	No	No	No	No
ES.B-01R	114 376	127 998	R	0–10; 10–20; 0–20	Yes	Yes	Yes	No	Yes	No	Yes
FR.B-01	11 432	11 432	R	0–30	Yes	No	No	No	Yes	No	Yes

FR.B-02	11 216	14 339	R	NA	Yes	No	No	No	No	No	No
FR.B-03	96 186	64 969	R	0–31	Yes	No	No	Yes	No	No	No
FR.B-04	68 838	68 258	R/D	0–30	Yes	Yes	No	No	No	No	No
FR.B-05	45 717	36 021	R	NA	Yes	No	No	No	No	No	No
FR.B-06	127 203	110 545	NA	0–20	Yes	No	No	No	No	No	No
FR.B-07	104 469	98 243	R	0–20	Yes	Yes	No	No	No	No	No
FR.B-08	80 000	65 000	R	0–31	Yes	No	No	No	No	No	No
FR.B-09	5 837	4 161	R	0–45	Yes	Yes	No	No	No	No	No
FR.B-10	4 810	3 900	NA	NA	Yes	No	No	No	No	No	No
IT.B-01	132 217 39 592.81	158 900	NA	0–2; 2–4; 0–4; 4–10	No	No	Yes	No	Yes	No	No
IT.B-02	301 288 30 779	290 000	R	0–6; 0–20	Yes	Yes	No	No	No	No	Yes
NL.B-01	205 131	184 151	R	0–22	Yes	No	No	No	No	No	No
NL.B-02	240 559	150 029	R	0–40	Yes	No	No	No	No	No	No
NL.B-03	616 072	568 631	R	0–11; 0–32	Yes	No	No	No	Yes	No	No
PT.B-01	112 506	50 353	R	0–31	Yes	No	No	No			Yes
PT.B-02	18 179	NA	NA	NA	NA	NA	NA	NA	NA	NA	NA
SE.B-01	87 000	87 000	NA	0–4; 4–60; > 60	Yes	No	No	No	No	No	No
SE.B-02	129 905	121 000	NA	0–50	Yes	No	No	No	No	No	No
SE.B-03	99 275	77 534	R/D	0–60; > 60	Yes	Yes	No	No	No	No	No
UK.B-01	171 196	125 806.1	R	0–40;	Yes	No	No	No	No	No	No
NB: NA = not available. R = Recovery; D = Disposal. RC = road construction or earthworks; L = landfill; OS = other structures; U = underground; RP = recovery in product; AF = recovery in agriculture or fertiliser; OR = other recovery. Source: [81, TWG 2016]											

Table 3.54 gives an overview of the bottom ash quality after the treatment. This information can be compared with the information on the leaching values of the raw bottom ash produced by incineration plants given in Table 3.19.

Table 3.28: Leaching values of bottom ash after treatment

Component	Average (mg/kg)	Minimum (mg/kg)	Maximum (mg/kg)
Chloride	1 930	100	5 800
Sulphate	2 118	50	6 410
Lead	1	0.01	11
Copper	5	0.05	80
Nickel	0.17	0.01	1
Arsenic	0.4	0.01	2
Molybdenum	0.6	0.01	5
Antimony	0.2	0.01	1
Cadmium	0.01	0.003	0.05
Zinc	1	0.005	9
Vanadium	0.1	0.03	0.2
Total chromium	0.23	0.01	2
COD	158	1	670

NB: Ratio L/S = 10 l/kg.
The reported values are calculated from information provided by the following plants:
AT.B-01, BE.B-02, DE.B-05, DE.B-12, DE.B-14, ES.B-01R, FR.B-01, FR.B-02, FR.B-03, FR.B-04, FR.B-05,
FR.B-06, FR.B-08, FR.B-09, FR.B-10, IT.B-02, NL.B-01, NL.B-02, NL.B-03, PT.B-01, SE.B-03.
Source: [81, TWG 2016]

3.4.3.2 Emissions to air

Emissions to air from an incineration bottom ash/slag treatment plant are likely to be dust including metal particles. Emissions of dust and metals come mainly from the slag/ash handling, the shredding and the air separation. Table 3.29 shows the achieved dust emission levels of some EU plants with the techniques applied to reduce emissions to air and the emission sources.

Table 3.29: Dust emissions to air from incineration bottom ash treatment – Periodic measurements

Plant	Channelled emission from:	Tech.	Flow rate (Nm ³ /h)			Dust (mg/Nm ³)		
			Max.	Avg.	Min.	Max.	Avg.	Min.
CZ B-01	Shredder; Sieve; Conveyor belt; Hall air suction	B	98 120	68 540	54 040	0.7	0.3	0.2
DE B-05	Air separation	B	30 000	25 750	21 500	0.9	0.5	0.1
DE.B-10	Conveyor belt; Hall air suction	NR	NR	NR	NR	3.8	2.3	0.9
IT.B-01	Shredder; Sieve; Conveyor belt	C, B	NR	52 000	NR	1.9	1.8	1.7
IT.B-02	Shredder; Sieve; Conveyor belt; Hall air suction	C, B	200 000	180 000	160 000	0.2	0.2	0.2

NB: NR = not reported; B = bag filter; C = cyclone.
Source: [81, TWG 2016]

3.4.3.3 Emissions to water

Waste water comes mainly from the wet process and the washing process. Process waste water contains salts and metals as well as suspended solids and organic substances including PCDD/F.

Table 3.30 summarises the levels of emissions to water reported through the 2016 data collection. It also gives an indication of the techniques and the types of process applied.

Table 3.30: Reported emissions to water from the treatment of incineration slags and bottom ashes with the techniques used and points of release

Plant	CZ.B-01R	DE.B-03	DE.B-07	DE.B-08	FR.B-03	FR.B-06	FR.B-07	FR.B-08	FR.B-09	IT.B-01	IT.B-02	NL.B-03	PT.B-01 ⁽¹⁾	UK.B-01	
Bottom ash treatment plant and WIP within same plant?	Yes	No	No	No	Yes	No	No	No	Yes	No	No	No	No	No	
WWT within installation?	No	Yes	Yes	No	Yes	Yes	No	Yes	No	Yes	Yes	Yes	Yes	No	
Type of treatment	Wet	Wet	Dry	Dry	Dry	Dry	Dry	Dry	Dry	Wet/Dry/Wash	Wet/Dry/Wash	Dry	Dry	Dry	
Techniques	Sed/Neut/CP	Sed	Sed/OS	Sed/ OS/Fil	Sed/Fil	Fil	Fil	Sed/Neut/CP/OS/Fil	Neut/CP/OS/Fil	OS	Sed/Neut/CP	Sed/Neut/CP/OS/Fil	Sed/CP/Fil	Sed/Neut/ CP	---
Flow rate (m ³ /h)	Max.	NA	NA	NA	NA	NA	NA	NA	40	NA	NA	7.7	50	25.7	NA
	Avg.	2.1	7	NA	0.16	NA	NA	NA	10	NA	15	7.5	35	1.4	NA
	Min.	NA	NA	NA	NA	NA	NA	NA	NA	NA	NA	7.2	19	0	NA
Conductivity (µS/cm)	Max.	848	42 000	8 900	NA	NA	NA	660	NA	NA	7 120	8 280	NA	16 400	848
	Avg.	707	21 930	8 500	1 915	NA	NA	368.55	NA	NA	4 230	2 020	NA	11 120	707
	Min.	622	8 600	NA	NA	NA	NA	77.1	NA	NA	NA	465	NA	8 600	NA
Sulphate (mg/l)	Max.	NA	1 300	NA	NA	NA	NA	NA	NA	NA	370	348	790	600	664
	Avg.	NA	782	NA	NA	NA	NA	NA	NA	NA	289	155	380	600	647
	Min.	NA	39	NA	NA	NA	NA	NA	NA	NA	NA	20	260	600	630
Ammonium-N (mg/l)	Max.	29.3	2.6	NA	NA	NA	NA	NA	NA	NA	8.4	7	40	33.2	0.18
	Avg.	14.68	1.21	NA	0.16	NA	NA	NA	NA	NA	4.9	1.7	13	18	0.13
	Min.	6.95	0.22	NA	NA	NA	NA	NA	NA	NA	NA	0.1	6	6.2	0.0095
Lead (mg/l)	Max.	0.015	0.48	NA	NA	NA	0.01	0.004	1	0.005	< 0.02	0.01	0.012	< 0.50	0.016
	Avg.	0.015	0.13	0.01	0.0048	NA	0.01	0.003	0.07	0.005	< 0.02	0.01	0.011	< 0.50	0.022
	Min.	0.015	0.01	NA	NA	NA	0.01	0.002	0.01	0.005	NA	0.01	0.01	< 0.50	0.006
Total suspended solids (mg/l)	Max.	104	2	NA	NA	8	NA	5	600	6.5	< 10	22	64	140	NA
	Avg.	50.5	0.85	0.1	NA	7.5	NA	3.7	400	4.75	< 10	11	24	140	65.2
	Min.	28	0.2	NA	NA	6	NA	2.4	10	3	NA	10	4	140	NA
TOC (mg/l)	Max.	NA	NA	NA	NA	NA	NA	NA	NA	9.6	NA	NA	NA	NA	NA
	Avg.	NA	NA	NA	NA	NA	NA	NA	NA	9.5	NA	NA	NA	NA	NA
	Min.	NA	NA	NA	NA	NA	NA	NA	NA	9.4	NA	NA	NA	NA	NA
PCDD/F (ng I-TEQ/l)	Max.	NA	NA	NA	NA	NA	NA	NA	NA	0.03	NA	NA	NA	NA	NA
	Avg.	NA	NA	NA	NA	NA	NA	NA	NA	0.0235	NA	NA	NA	NA	NA
	Min.	NA	NA	NA	NA	NA	NA	NA	NA	0.017	NA	NA	NA	NA	NA
Chloride (mg/l)	Max.	50	10 300	NA	NA	NA	NA	NA	NA	220	850	1 937	3 900	5 350	1 770
	Avg.	40.5	6 130	NA	138	NA	NA	NA	NA	165	NA	702	2 800	3 604	1 640
	Min.	36	1 400	NA	NA	NA	NA	NA	NA	110	757	63	1 800	2 430	1 511
Copper (mg/l)	Max.	NA	0.43	NA	NA	NA	NA	NA	NA	NA	NA	NA	0.045	NA	NA
	Avg.	NA	0.22	NA	NA	NA	NA	NA	NA	NA	NA	NA	0.022	NA	NA
	Min.	NA	0.04	NA	NA	NA	NA	NA	NA	NA	NA	NA	0.011	NA	NA
Receiving water body	Artificial water body (eg. reservoir)	Artificial water body (eg. reservoir)	NA	River/ Stream	NA	River/ Stream	Artificial water body (eg. reservoir)	Artificial water body (eg. reservoir)	River/ Stream	River/ Stream	Lake	NA	NA ⁽¹⁾	Artificial water body (eg. reservoir)	

⁽¹⁾ The waste water composition of PT.B-01 refers to waste water from the bottom ash treatment plant before it enters the waste water pre-treatment within the installation. After the waste water pre-treatment within the installation (which has a biological treatment followed by a physico-chemical treatment), the effluent is discharged into the municipal drainage system and goes to the municipal waste water treatment.

NB: Type of treatment: Wash = Bottom Ash Washing; Sed = Sedimentation; Neut = Neutralisation; CP = Chemical precipitation; OS = Oil separation; Fil = Filtration; NA = not available.

Source: [81. TWG 2016]

3.4.3.4 Energy consumption

The energy input in the form of electrical power depends directly on the plant capacity, types of processes and technologies used. It is thus very specific to each individual case and is only comparable to a limited extent.

Table 3.31 reports the installed power as well as the consumption of electricity, steam, fuels and water by the plants. No data are available on the detailed monitoring/metering by process of the power (electrical and fuel consumption) used to run individual processes.

Table 3.31: Energy and water use reported in 2014 by incineration bottom ash treatment plants

Plant	Treatment capacity (t/yr)	Installed power (kVA)	Energy and water consumption					Rainwater reused (m ³)
			Electricity (kWh)	Liquid fuel(l)	Natural gas (kWh)	Steam (kWh)	Water (m ³)	
AT.B-01	40 000	200	NA	30 587	0	0	848	0
BE.B-01	100 000	174	295 630	0	0	0	NA	NA
BE.B-02	87 813 ⁽¹⁾	439	NA	0	0	0	11 415	14 050
DE.B-01	180 000	350	205 000	110 000	NA	NA	1 400	NA
DE.B-02	400 000	1 200	989 000	0	0	0	18 500	0
DE.B-03	300 000	175	371 000	82 900	0	0	5 896	2 495
DE.B-04	600 000	1 254.1	1 985 861	0	0	0	0	47 000
DE.B-05	340 000	640	638 216	267 132	0	0	0	13 500
DE.B-06	216 000	NA	438 000	60 000	NA	NA	NA	NA
DE.B-07	450 000	630	300 000	0	0	0	0	0
DE.B-08	250 000	400	420 000	40 000	0	0	1 200	0
DE.B-09	70 000	NA	368 000	NA	0	175 000	0	0
DE.B-10	90 000	432	1 110 000	24 000	0	0	0	0
DE.B-11	90 000	200	1 500 000	20 000	0	0	0	0
DE.B-12	79 000	NA	343 900	0	0	0	0	0
DE.B-13	140 000	800	117 023	0	0	0	323	9 270
DE.B-14	64 262 ⁽¹⁾	270	NA	0	0	0	300	300
DK.B-01	125 000	NA	80 000	NA	0	0	0	NA
DK.B-03	180 000	280	10 000	5 000	0	0	0	4 000
ES.B-01	200 000	470	238 996	5 855	0	0	1 484.4	0
FR.B-01	5 500	32	278 400	19 100	0	0	0	0
FR.B-03	90 000	204	221 830	62 068	0	0	380	900
FR.B-04	87 000	260	125 000	42 992	0	0	46	0
FR.B-05	54 250	200	100 000	36 000	0	0	261	NA
FR.B-06	200 000	412	660 000	52 000	0	0		0
FR.B-07	120 000	630	210 360	62 540	0	0	91	0
FR.B-09	7 000	7.5	52 616.25	8 000	0	0	0	0
FR.B-10	20 000	62	NA	7 810	0	0	NA	0
IT.B-01	250 000	1 000	1 217 063	630	45 283	0	21 083	0
IT.B-02	620 000	700	1 680 000	0	0	0	3 000	3 000
NL.B-01	180 000	800	800 000	0	0	0	0	0
NL.B-02	320 000	NA	650 000	0	0	0	0	0
NL.B-03	700 000	1 070	1 115 877	157 440	0	0	20	0
PT.B-01	200 000	100	94 866	67 877	NA	NA	NA	24 304
SE.B-01	87 000	NA	80 000	0	0	0	100	0
SE.B-02	129 905 ⁽¹⁾	NA	NA	0	0	0	5 000	0
UK.B-01	200 000	500	212 138	NA	NA	NA	40 206	NA

NB: NA = not available.
⁽¹⁾ Capacity data not available; value refers to quantity treated in 2014.
Source: [81, TWG 2016]

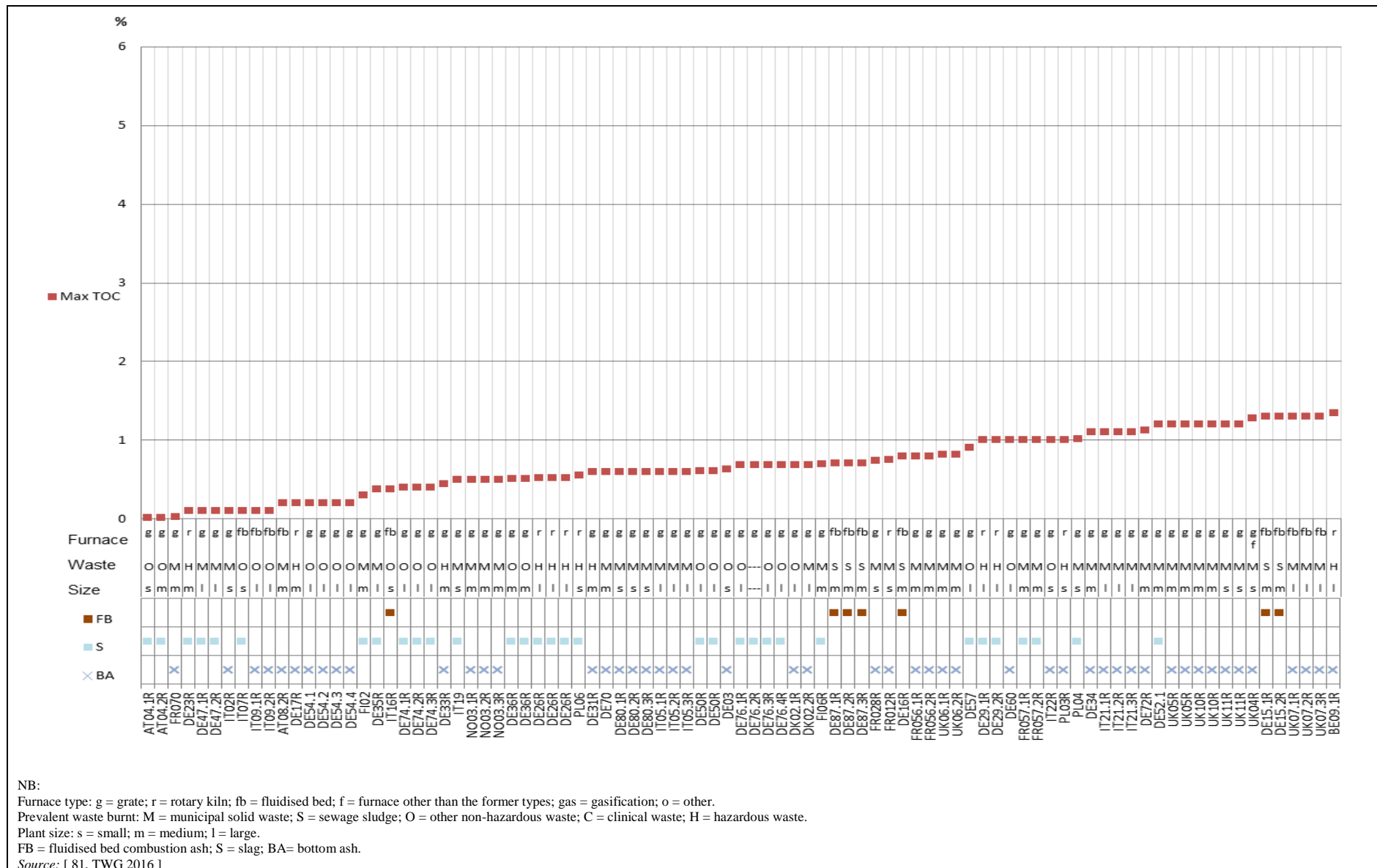

Figure 3.82: TOC content in untreated incineration slags and bottom ashes (1/2)

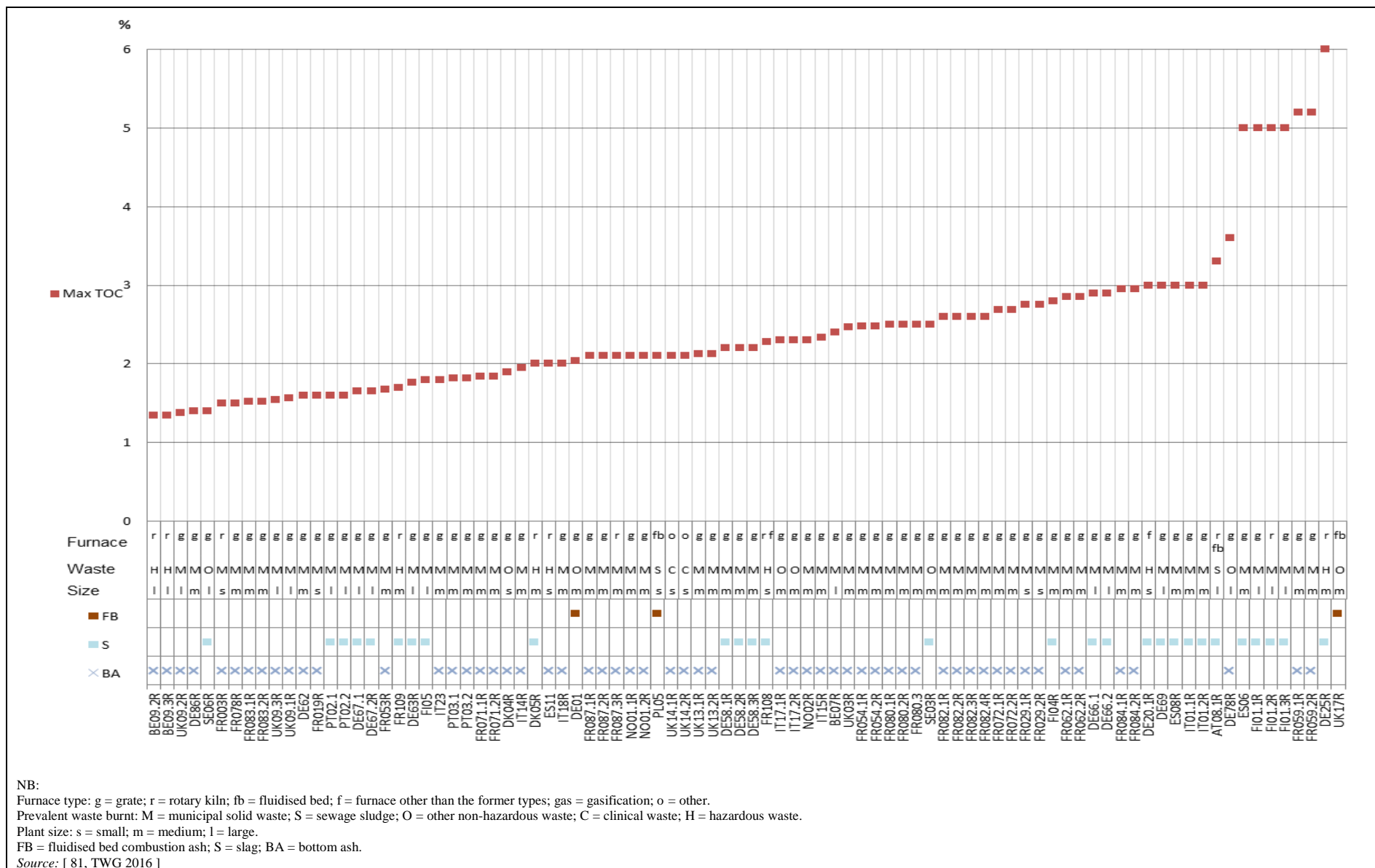

Figure 3.83: TOC content in untreated incineration slags and bottom ashes (2/2)

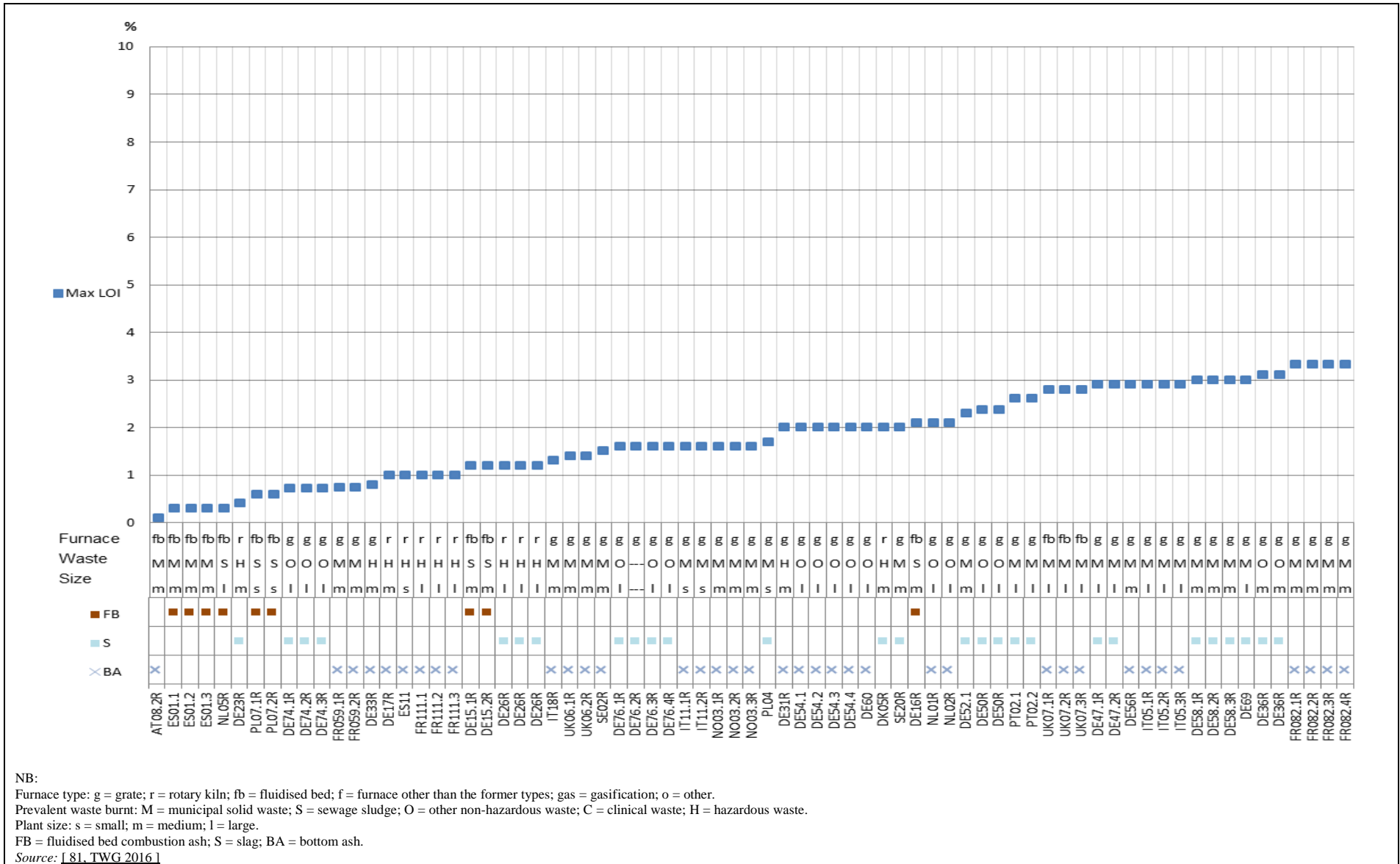

Figure 3.84: LOI of untreated incineration slags and bottom ashes (1/2)

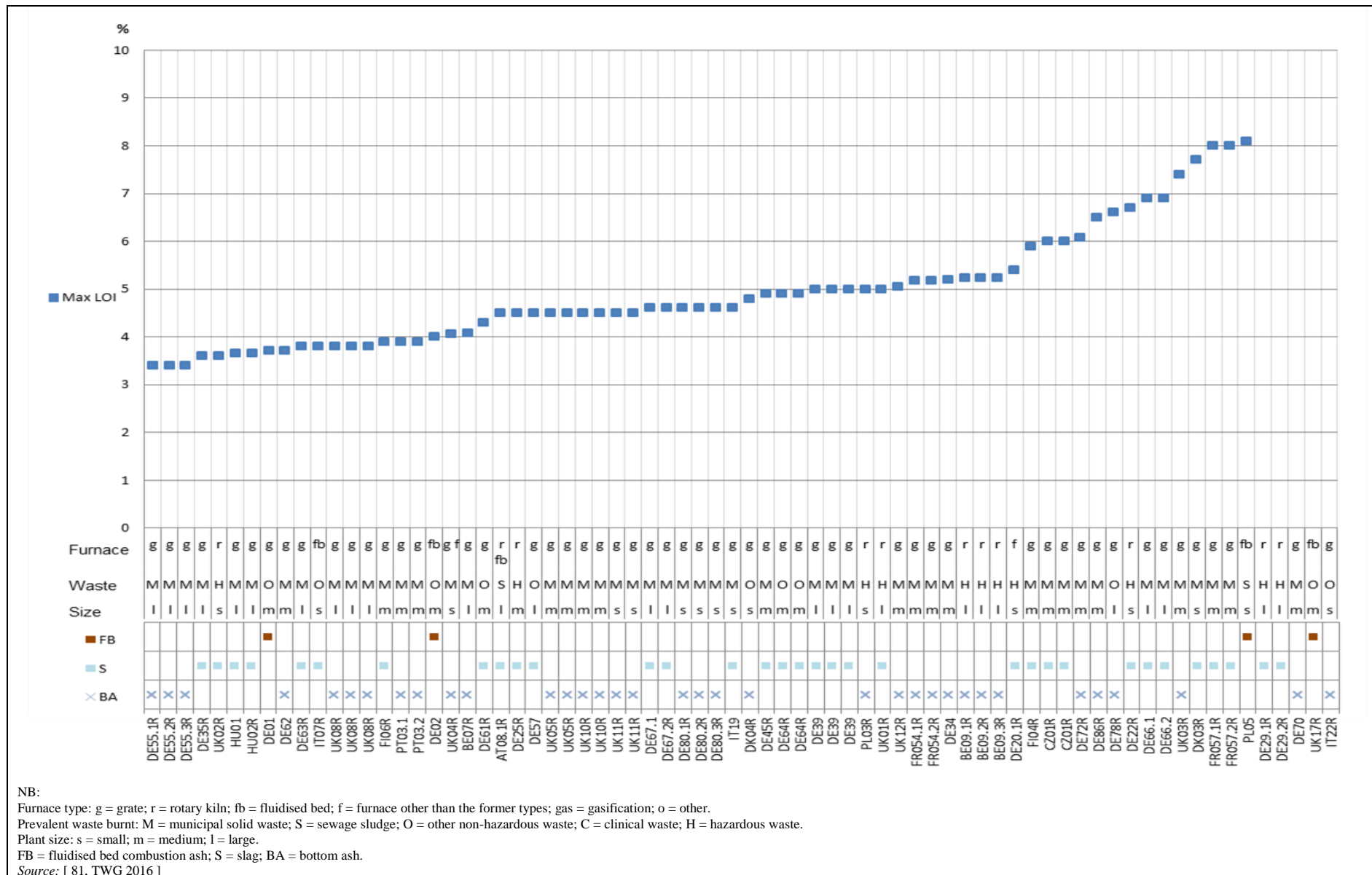

Figure 3.85: LOI of untreated incineration slags and bottom ashes (2/2)

3.5 Energy consumption and production

Energy inputs to the incineration process may include:

- waste (mainly);
- support fuels (usually a very limited amount; support fuel is needed for the incineration of waste with a low LHV such as non-dried sewage sludge);
- imported electricity (if any).

Production and exports may include:

- heat (as steam or hot water);
- electricity.

Pyrolysis and gasification processes may export some of the energetic value of the incoming waste with the substances they export, e.g. syngas, chars, oils. In many cases these products are either directly or subsequently burned as fuels to utilise their energy value, although they may also be used for their chemical value as a raw material, after pre-treatment if required.

Most incineration plants in Europe produce and export electricity, heat or both.

The combination of energy exports depends on a number of factors. Often the existence of local demand for steam or heat drives the supply. The relative prices for the supply of the energy produced and the duration of sales contracts are generally seen as key factors in determining the outcome. This, in turn, is an important driver for the technological decisions regarding the process design. Some of these factors are described in Table 3.32 below.

Table 3.32: Factors influencing energy recovery options

Factor	Influence
High electricity price paid for supply or reliable demand	<ul style="list-style-type: none"> • Encourages investment to produce electricity • Boiler cladding may be purchased to allow higher steam pressures and greater electrical outputs • Less heat will be available for supply • Plant may import electricity to ensure own produced exports can be maximised
Higher electricity price for imported electricity than that produced	<ul style="list-style-type: none"> • Encourages the use of own produced electricity for running the incineration process • Heat-only plants may decide to divert some energy to supply own electricity demands
Higher price paid for heat and higher reliability of demand	<ul style="list-style-type: none"> • Investment in distribution networks becomes more viable • Overall plant efficiency gains possible due to ability to supply more of the recovered energy
Colder climate	<ul style="list-style-type: none"> • Can allow heat supply over more months of the year
Hotter climate	<ul style="list-style-type: none"> • Less reliable heat demand for heating • May increase options to supply heat to drive chillers for air conditioning, to feed seawater thermal desalination plants, etc.
Baseload energy supply contract	<ul style="list-style-type: none"> • Increases reliability of sales contract and encourages investment in techniques to utilise available energy (heat and electricity)
Not permitted to discharge treated waste water from wet scrubbers	<ul style="list-style-type: none"> • Reduction in available heat for export owing to need to supply evaporation energy
Vitrification of ash required	<ul style="list-style-type: none"> • Higher plant energy demand results in increased self-consumption and reduced outputs
Higher incineration temperature required	<ul style="list-style-type: none"> • Possible need for additional fuels to obtain the required temperature
<i>Source: [122, COM 2006]</i>	

3.5.1 Energy efficiency calculation for waste incineration plants

The energy efficiency relates the input chemical energy contained in waste (normally expressed as the LHV) with the useful energy produced (electrical and thermal) that is recovered rather than being dissipated (through the flue-gas, cooling system, radiation, etc.). Where relevant, other energy inputs are taken into account (e.g. support fuels, electrical or steam energy). The energy efficiency of a waste incineration installation is often expressed as a percentage. The energy efficiency can be used to compare the performance of different technical units and systems. For comparability, it is important to ensure that energy efficiency figures are calculated in a consistent manner. This requires taking into account the following, when calculating the energy efficiency:

1. The boundaries of the system/calculation need to be clearly defined

A clear definition of the balance room is the basic requirement to establish any mass, material or energy balance. A reference entity is created to define the scope of the evaluation (e.g. a boiler, a waste incineration line including its flue-gas cleaning system and turbo-generator set, an entire plant).

For the sake of comparability, it is necessary to take into account the type of waste incinerated and not only the waste delivered to the installation. If the incoming waste requires significant pre-treatment (e.g. crushing, shredding, drying), this can result in significant additional energy requirements.

2. All energy inputs need to be accounted for

Some installations use additional fuels to maintain combustion temperatures. The energy recovered at the installation will be partly derived from the waste and partly derived from the additional fuel.

3. Own energy consumption and internal energy flows need to be accounted for in a consistent manner

In some cases, electricity and/or heat that is recovered from the waste is then used within the installation. Accounting for this results in a net reduction of exported energy and in an equivalent reduction of imported energy.

4. All assumptions need to be made clear and consistently adhered to

Simple addition of the electrical and heat outputs can create difficulties when considering the relative efficiencies of installations that produce different quantities of these energy flows. The use of equivalence factors is a possible approach to allow the consideration of the relative value of these commodities.

A different approach is used in this document, based on the identification of different cases that are internally comparable: 1) plants mainly oriented towards the destruction of waste, such as plants dedicated to the incineration of hazardous waste (other than hazardous wood waste) and of sewage sludge; 2) plants mainly oriented towards the production of electricity with a condensing turbine; 3) plants mainly oriented towards the production of heat/steam, possibly in combination with a back-pressure turbine; 4) hybrid plants where different parts of the plant may have a different orientation. Detailed examples of several cases are presented in Annex 8.2.

Furthermore, the relevant time dimension needs to be univocally fixed, either as a short-term status (e.g. at the time of a performance test, typically lasting around 8 hours) or over a certain period of time (e.g. as an annual average). The energy efficiency data presented in this section are in principle derived from the performance test that the plant underwent to check its real

performance when it was first commissioned or after significant changes. However, the performance test data were not available in all cases: while performance tests are generally carried out for furnaces/boilers and for turbo-generator sets, this is not the case for district heating heat exchangers or for direct export systems for steam or hot water. The nominal design values initially provided by the suppliers and/or updated operating data were used as an alternative.

The energy efficiency may be assessed at the level of the waste incineration plant, with the system boundary shown in Figure 3.86, or at the level of a part of the waste incineration plant in cases where the amounts of energy recovered by different parts of the plant cannot be appropriately summed together for example. Detailed examples of such situations are presented in Annex 8.2.

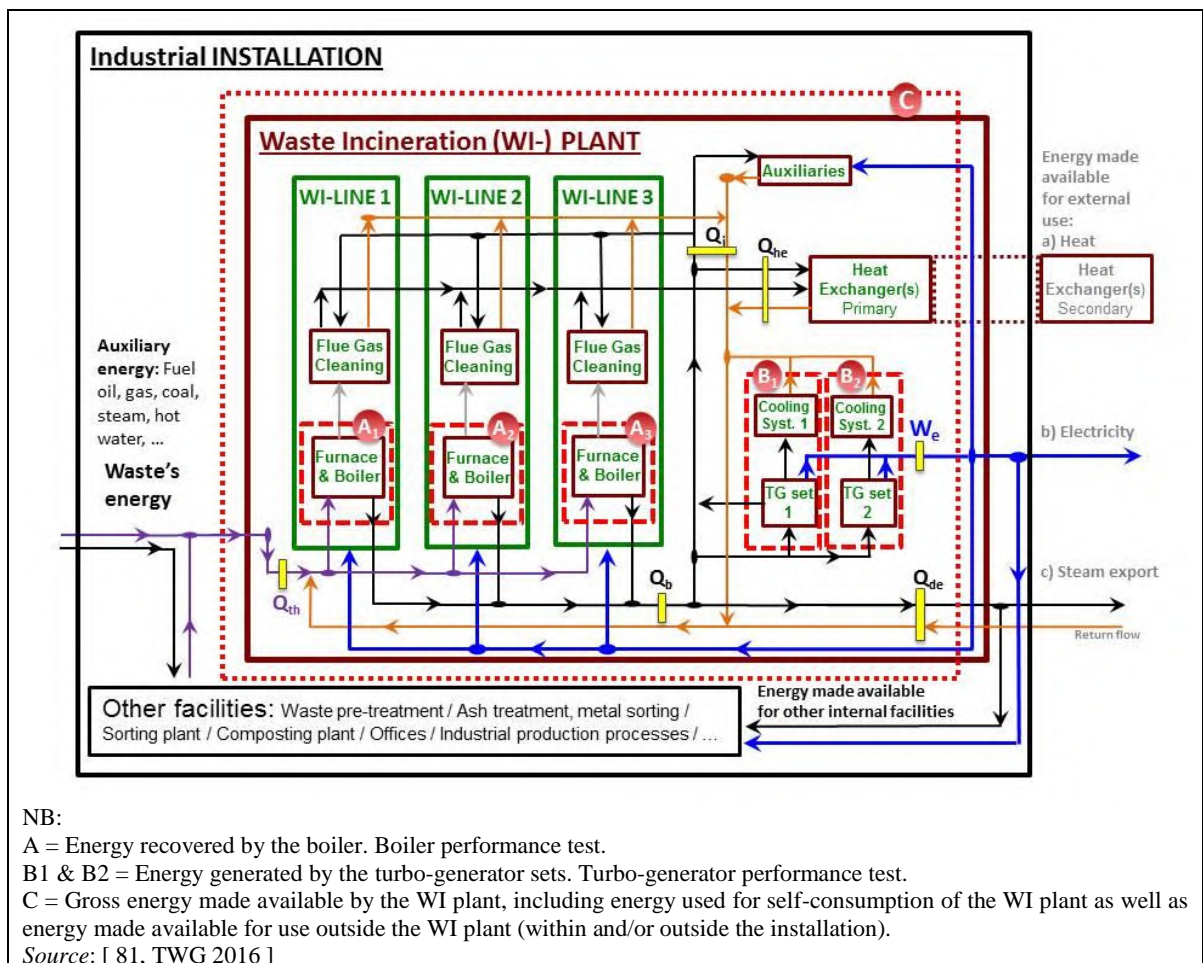

Figure 3.86: System boundary used for the calculation of the energy efficiency

Figure 3.86 shows the energy balance boundaries representative of the energy efficiency concepts that are generally used within this document for the determination of the energy efficiency, which refer to gross, rather than net, energy efficiency. This means determining the energy efficiency in terms of all the energy that is made available by the WI plant, including: the energy used by the plant itself for internal uses (e.g. to run the flue-gas cleaning system); the energy used by the broader installation (e.g. to run a waste pre-treatment plant that may be on site); and the energy available for export.

In Figure 3.86, the energy flows are depicted using the following colour code:

- in purple, the energy input into the furnace(s), as waste as well as auxiliary fuels;
- in grey, the energy contained in the flue-gas at the exit of the boiler;
- in black, the energy contained in the steam and/or hot water generated in the heat recovery boiler(s) as well as recovered in the flue-gas cleaning system (for instance when using flue-gas condensation);
- in orange, the return flows of the steam/hot water system;
- in blue, the electricity that is generated by the turbo-generator sets, used within the plant or the broader installation, or exported.

The red dotted line (C) represents the boundary of the gross energy efficiency calculation used to determine the energy efficiency of the plants that participated in the 2016 data collection for the review of the WI BREF. In this context, the following quantities are identified in Figure 3.86:

- W_e is the electrical power generated, in MW;
- Q_{he} is the thermal power supplied to the heat exchangers on the primary side, in MW;
- Q_{de} is the directly exported thermal power (as steam or hot water) less the thermal power of the return flow, in MW;
- Q_b is the thermal power produced by the boiler, in MW;
- Q_i is the thermal power (as steam or hot water) that is used internally (e.g. for flue-gas reheating), in MW;
- Q_{th} is the thermal input to the thermal treatment units (e.g. furnaces), including the waste and auxiliary fuels that are used continuously (excluding for example for start-up), in MWth expressed as lower heating value.

The energy efficiency levels achieved by plants mainly incinerating non-hazardous waste other than sewage sludge and hazardous wood waste are reported in the following sections:

Section 3.5.2.1 reports the gross electrical efficiency (η_e) of incineration plants (or parts thereof) that produce electricity using a condensing turbine; η_e is expressed as:

$$\eta_e = \frac{W_e}{Q_{th}} \times (Q_b / (Q_b - Q_i))$$

Section 3.5.2.2 reports the gross energy efficiency (sum of heat and electricity, η_h) of incineration plants (or parts thereof) that produce only heat, or produce electricity using a back-pressure turbine and heat with the steam leaving the turbine; η_h is expressed as:

$$\eta_h = \frac{W_e + Q_{he} + Q_{de} + Q_i}{Q_{th}}$$

3.5.2 Data on the recovery of energy from waste

[1, UBA 2001]

The parameters (temperature and pressure) of the steam generated by the heat recovery boiler are limited by:

- the high-temperature corrosion that may occur in the heat conversion area (boiler, economiser, etc.) due to the contents of certain materials, including chlorine, in the waste;
- fouling of the boiler – above approximately 600 °C to 800 °C the ashes are sticky due to the presence of some smelting substances.

The steam parameters (and hence electrical efficiency) of incineration plants are therefore limited. A steam pressure of 90 bar and a temperature of 535 °C can be considered the maximum at present (2014), and only then where special measures are taken to limit corrosion.

For electricity production from MSW, typical superheated steam conditions are 40 bar to 70bar and 400 °C to 450 °C, with the higher ends of these ranges more frequently observed in larger plants. Lower parameters, generally in the range of 30 bar and 350 °C, are applied where electricity is generated from hazardous wastes owing to the increased corrosion risks (leading to operational difficulties and costs) with acidic flue-gases at higher steam parameters.

Where only heat or steam is supplied, operators tend to use lower boiler pressures and temperatures to avoid the need for the additional investment and maintenance and the more complex operating conditions associated with higher parameters. In the case where heat supply is prioritised, high pressure and temperature are not justified. For heat supply, the steam will typically be generated at lower values, e.g. around 25 bar to 30 bar and 250 °C to 350 °C.

The majority of waste incinerators in Europe, and even more so in the case of larger plants, recover energy from the waste. Plants without heat utilisation are generally related to very specific designs, such as those of some plants incinerating halogenated hazardous wastes at temperatures higher than 1 100 °C, where the stickiness of the fly ash may pose additional challenges to the operation of a heat recovery boiler. In such cases, the risk of PCDD/F reformation may be avoided by using flue-gas quenching; some heat may still be recovered from the hot quench water and/or from gas-gas heat exchangers to recover part of the energy of the hot flue-gas at the exit of the post-combustion chamber before the quench.

The steam parameters (pressure and temperature at the turbine entrance) of the plants that participated in the 2016 data collection are shown in graphs in the figures referenced in this section. The size and the age of the plants are also reported, as well as whether they produce only heat (H), electricity (E) or both (C). The age is defined as 'recent' for plants that first came into operation after 2006, as 'intermediate' for plants that first came into operation between 2000 and 2006, and as 'old' for plants that first came into operation before 2000. The size is defined as 'small' for plants with an incineration capacity below 100 000 t/yr (below 48 000 t/yr in the case of plants predominantly incinerating hazardous wastes), as 'medium' for plants with an incineration capacity between 100 000 t/yr and 250 000 t/yr (between 48 000 t/yr and 80 000 t/yr in the case of plants predominantly incinerating hazardous wastes), and as 'large' for plants with an incineration capacity above 250 000 t/yr (above 80 000 t/yr in the case of plants predominantly incinerating hazardous wastes).

The temperature and pressure of the steam produced by plants mainly incinerating municipal solid waste, other non-hazardous waste and hazardous wood waste are shown in graphs in Figure 3.87, Figure 3.88, Figure 3.89 and Figure 3.90 along with the gross electrical efficiency or gross energy efficiency achieved by the plant.

In these graphs, the left-hand axis represents the gross electrical efficiency or the gross energy efficiency, while on the right-hand side of the graph two different axes are represented, associated with the temperature (in red) and pressure (in green) of the steam generated.

In the graphs, the plants are ordered according to the gross electrical or gross energy efficiency (lower to higher from left to right). The graphs confirm that plants generating electricity or combined heat and electricity generally operate with higher steam parameters than heat-only plants.

Table 3.33 shows the temperature and pressure of the steam at the turbine entrance or at the boiler outlet of plants incinerating predominantly hazardous wastes, excluding hazardous wood waste. All these plants are rotary kilns.

Table 3.33: Steam parameters of plants incinerating predominantly hazardous waste

Plant	Size	Steam pressure (bar)	Steam temperature (°C)	Energy production
AT08	l	53	350	CHP
DE18	l	27	270	Electricity
DE26	l	44	325	CHP
DE29	l	26	280	Electricity
ES11	s	41	350	Electricity
FR111	l	40	360	CHP
HU01	l	16	304	CHP
PL03	s	20	270	Electricity
SE21	l	41	400	CHP
NB: Size: l = large; s = small. Source: [81, TWG 2016]				

Table 3.34 shows the temperature and pressure of the steam at the turbine entrance or at the boiler outlet of plants incinerating predominantly sewage sludge. All these plants are fluidised bed incinerators.

Table 3.34: Steam parameters of plants incinerating predominantly sewage sludge

Plant	Size	Steam pressure (bar)	Steam temperature (°C)	Energy production
AT08	l	53	350	CHP
NL06	l	10	180	CHP
PL01	m	49	400	CHP
UK15	s	42	400	Electricity
NB: Size: l = large; m = medium; s = small. Source: [81, TWG 2016]				

The following sections report the energy efficiency levels (electricity and/or heat) achieved by the plants that participated in the 2016 data collection. The reported energy efficiency levels refer to the ratio between the plant's gross energy output(s) and the energy input (expressed as lower heating value) into the thermal treatment unit(s), including waste and other fuels, at actual plant design and for the plant operated at full load during the performance test.

3.5.2.1 Electricity recovery data

[1, UBA 2001]

The amount of electricity that can be generated with one tonne of municipal waste in a municipal waste incineration plant is dependent upon the size of the plant, steam parameters and degrees of steam utilisation and mainly on the calorific value of the waste.

The amount of energy available for export usually depends upon the amount produced and the degree of self-consumption by the installation – which can itself vary significantly. The FGC system's consumption is often significant and varies with the type of system applied (and emission levels required). In some cases, the energy required to run the installation is imported

from an external supply, with all of that generated by the installation being exported – the local balance usually reflects local pricing for the electricity generated compared to general grid prices.

The following graphs and tables show the gross electrical efficiency of the waste incineration plants that participated in the 2016 data collection for the review of the WI BREF. The efficiency is presented in the graphs alongside the steam parameters and the age and size of the plants ; plants are marked with E or C if they produce only electricity or heat and electricity, respectively.

The gross electrical efficiency of plants incinerating predominantly municipal solid waste or other non-hazardous waste are shown in graphs in Figure 3.87, Figure 3.88 and Figure 3.89. These graphs also include five plants dedicated to the incineration of hazardous wood waste, which are more similar to waste-to-energy plants than to hazardous waste incineration plants (e.g. for the processes used (all of these plants being based on grate furnaces) and for their focus on energy recovery). In general, smaller plants achieve lower electrical efficiency levels than medium and large plants. The graphs show the correlation between electrical efficiency and steam parameters, as most plants achieving a gross electrical efficiency below 25 % operate at temperatures below 400 °C and pressures below 40 bar, and all plants achieving a gross electrical efficiency above 30 % operate at temperatures above 420 °C and pressures above 60 bar. The graphs do not show a clear correlation between the achieved gross electrical efficiency and the plant age.

Table 3.35 shows the gross electrical efficiency of plants incinerating predominantly hazardous waste, excluding hazardous wood waste.

Table 3.35: Gross electrical efficiency of plants incinerating predominantly hazardous waste

Plant	Age	Size	Production	Efficiency (%)
DE18	O	Large	Electricity	14
ES11	O	Small	Electricity	15
DK05	I/ab	Medium	CHP	32
NB: Age: O = older; I = intermediate; Retrofitted ab = after 2006. Source: [81, TWG 2016]				

Table 3.36 shows the gross electrical efficiency of plants incinerating predominantly sewage sludge.

Table 3.36: Gross electrical efficiency of plants incinerating predominantly sewage sludge

Plant	Age	Size	Production	Efficiency (%)
NL06	O/ab	Large	Electricity	12
DE16	O/ab	Medium	Electricity	20.5
NB: Age: O = old; Retrofitted ab = after 2006. Source: [81, TWG 2016]				

3.5.2.2 Energy (heat or heat and electrical) recovery data

[1, UBA 2001]

Where energy can be supplied at baseload conditions, the gross degree of utilisation (electricity + heat) can be increased to around 90 % of the energy waste input (calorific value expressed as LHV). Higher values are achieved with the use of flue-gas condensation. [81, TWG 2016]

The gross energy (heat or heat and electrical) efficiency of the waste incineration plants that participated in the 2016 data collection for the review of the WI BREF is presented in this section alongside the steam parameters, and the age and the size of the plants; plants are marked with (H) or C if they produce only heat or heat and electricity, respectively.

The gross energy efficiency of plants incinerating wastes of all types is shown in Figure 3.90. The graph does not show a clear correlation between the gross energy efficiency and the age or size of the plant, or the temperature and pressure parameters of the steam generated. Note that AT08.1 has a combined energy recovery system made up of two hazardous waste incineration lines and three sewage sludge incineration lines. The figure 84 % represent the efficiency of the SS incineration lines only.

3.5.2.3 Boiler efficiency data

Plants incinerating predominantly hazardous waste or sewage sludge, due to their size (usually, especially for hazardous waste incinerators, smaller than waste-to-energy plants), their location (usually closer to where the waste is generated and possibly further from potential users of the recovered energy), and their design (more oriented towards waste destruction than to the exploitation of the waste energy content) may face challenges in optimising the use of the energy recovered.

For these reasons, for the incineration of hazardous waste and of sewage sludge, the efficiency in converting the energy content of the waste into steam or hot water (or boiler efficiency) may be used as a more widely comparable parameter to determine the energy efficiency performance.

The boiler efficiency for plants firing non-waste fuels may be generally determined using the standard BS EN 12952-15:2003 '*Water-tube boilers and auxiliary installations. Acceptance tests*'. This standard is intended as a basis for the thermal performance (acceptance) testing of direct-fired steam boilers and hot water generators. Such tests are designed to demonstrate that the guarantees with respect to efficiency and output or other parameters have been met. To overcome some specific challenges related to the waste firing, the German Fachverband Anlagenbau (FDBR) has developed a guideline for the determination of the boiler efficiency for the incineration of waste where it is difficult (or impossible) to determine the net calorific value of the fuel. According to this guideline, the boiler efficiency is the ratio between the useful heat output and the total heat supplied. The useful heat output is the total heat transferred to the water in the steam generator. [123, FDBR 2013]

The boiler efficiency presented in this section has been estimated taking into account the design data of the plants participating in the 2016 data collection for the review of the WI BREF.

The boiler efficiencies of the hazardous waste incineration lines that participated in the 2016 data collection are presented in Figure 3.91 alongside the age, size and the furnace type of the line as well as an indication of the maximum temperature reached by the flue-gas. Incineration lines generating only electricity, only heat, or heat and electricity are marked with E, H or C, respectively. The graph does not show a clear correlation between the boiler efficiency and the age or size of the plant. The graph shows, however, that lines incinerating waste at higher temperatures are generally limited to boiler efficiencies below 70 %.

The boiler efficiencies of the sewage sludge incineration lines that participated in the 2016 data collection are presented in Figure 3.92 alongside the age, size and the furnace type of the line as well as an indication of the water content of the sludge. Incineration lines generating only electricity, only heat, or heat and electricity are marked with E, H or C, respectively. The graph does not show a clear correlation between the boiler efficiency and the age or size of the plant. The graph shows, however, that lines incinerating sewage sludge with a lower water content generally achieve higher boiler efficiencies.

3.5.3 Data on the consumption of energy by the process

[1, UBA 2001]

The incineration process itself requires energy for its operation, e.g. pumps and fans. The demand varies greatly depending on the construction of the plant [1, UBA 2001]. In particular, the process demand may be increased by:

- mechanical pre-treatment systems (e.g. shredders), pumping devices or other waste preparation;
- incineration air preheating;
- reheating of flue-gas (e.g. for gas treatment devices or plume suppression);
- operation of waste water evaporation plant;
- flue-gas treatment systems with high pressure drops (e.g. filtration systems) which require higher powered forced draught fans;
- decreases in the calorific value of the waste – as this can result in the need to add additional fuels in order to maintain the minimum combustion requirements;
- sludge treatment, e.g. drying.

[64, TWG 2003]

In some cases, these demands can be met partially or entirely through heat exchange with the hot incineration gases.

Older plants with retrofitted flue-gas cleaning systems may consume more electricity compared with modern plants with integrated systems. For industrial hazardous waste incineration plants, a range of 132–476 kWh/t of waste is seen. [1, UBA 2001]

Table 3.37 below shows the specific energy demand of waste incineration plants that participated in the 2016 data collection exercise. The table shows the electricity demand and the heat demand for the entire incineration plant, expressed per tonne of treated waste.

Table 3.37: Electricity and heat demand data per tonne of waste treated

Energy demand type	Waste incinerated	Minimum	Average	Maximum
Electricity (MWh _e /t waste)	MSW&ONHW	0.045	0.107	0.264
	SS	0.033	0.154	0.276
	CW	0.211	0.228	0.244
	HW	0.073	0.202	0.360
Heat (MWh _h /t waste)	MSW&ONHW	0.010	0.505	0.700
	SS	0.121	0.265	0.675
	CW	NI	NI	NI
	HW	0.056	0.373	0.674
NB: NI = no information available. Source: [81, TWG 2016]				

The energy consumption of the plant also varies according to the calorific value of the waste. This is largely due to the increased flue-gas volumes with higher LHV waste – requiring a larger FGC capacity. This may be different in cases where the low LHV may be due to a high moisture content, which increases the flue-gas volume.

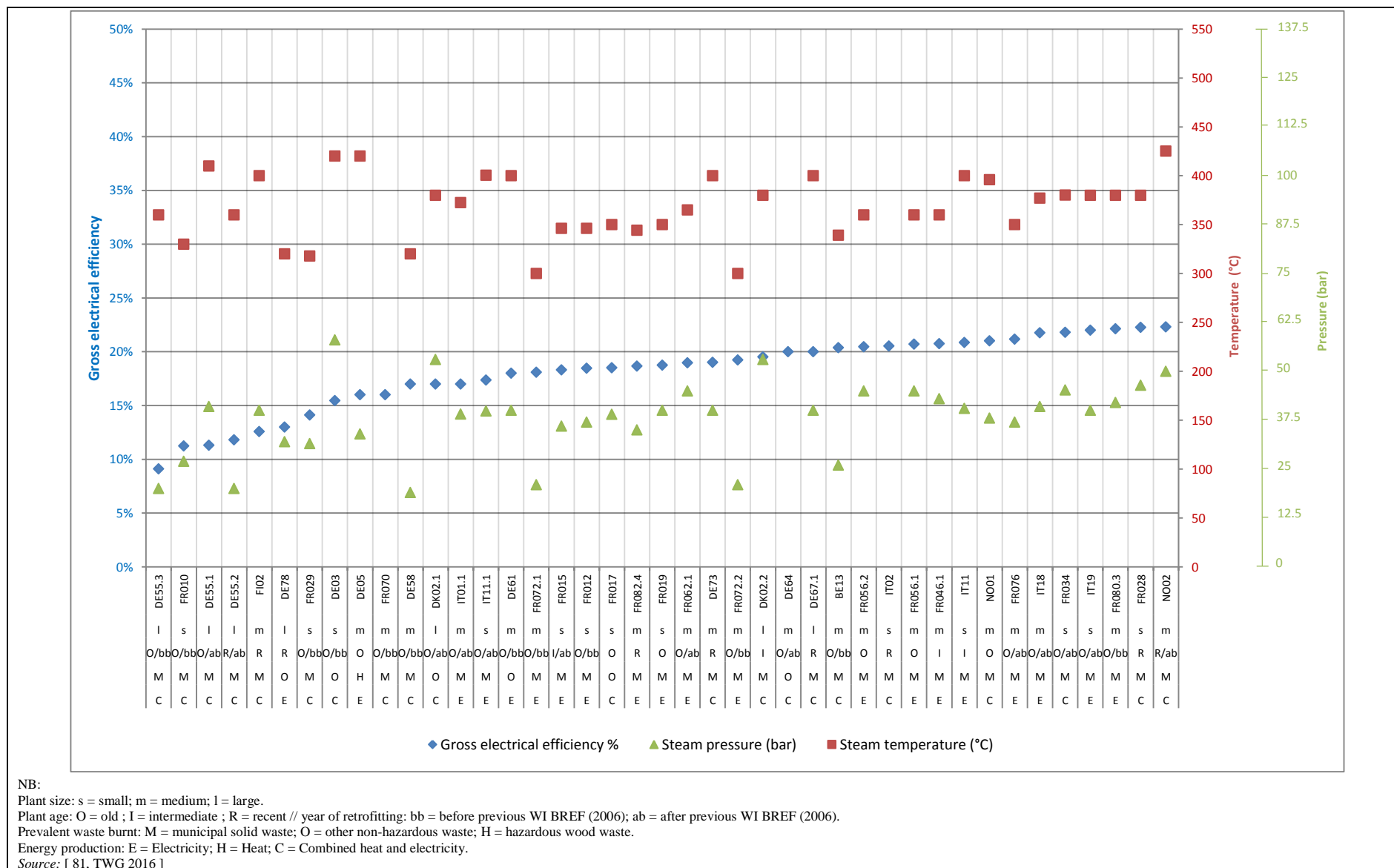

Figure 3.87: Gross electrical efficiency of plants incinerating predominantly municipal solid waste, other non-hazardous waste and hazardous wood waste (1/3)

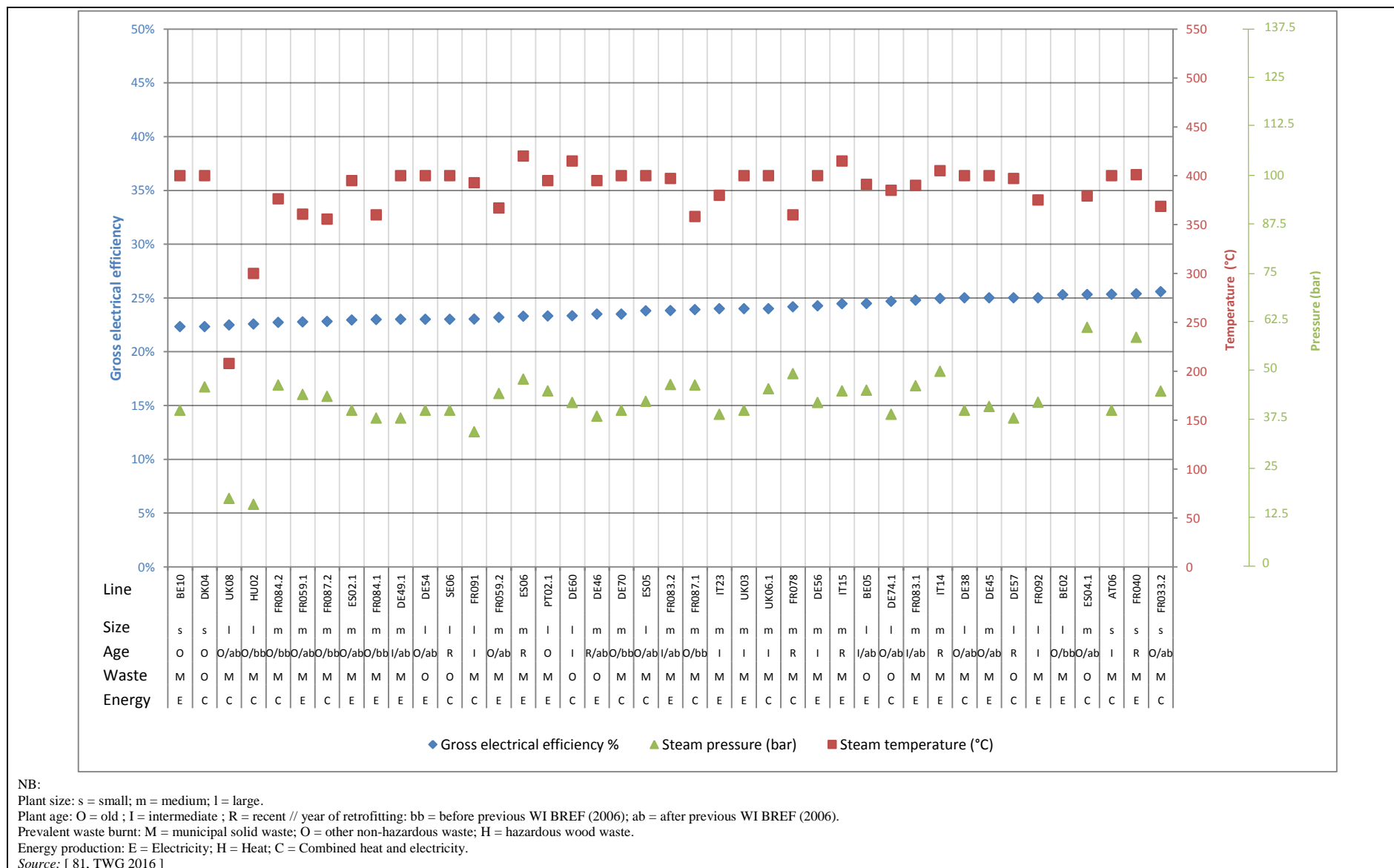

Figure 3.88: Gross electrical efficiency of plants incinerating predominantly municipal solid waste, other non-hazardous waste and hazardous wood waste (2/3)

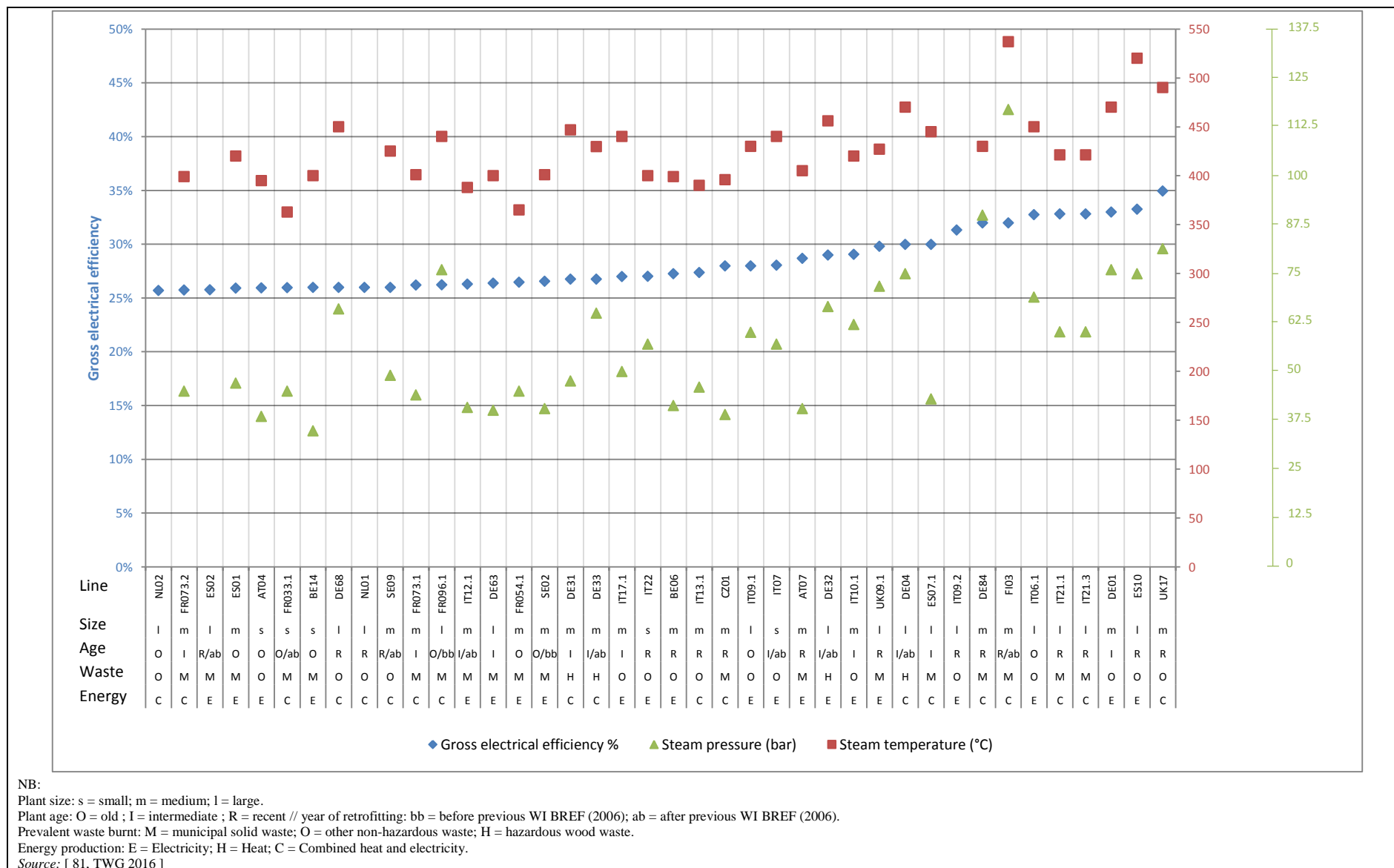
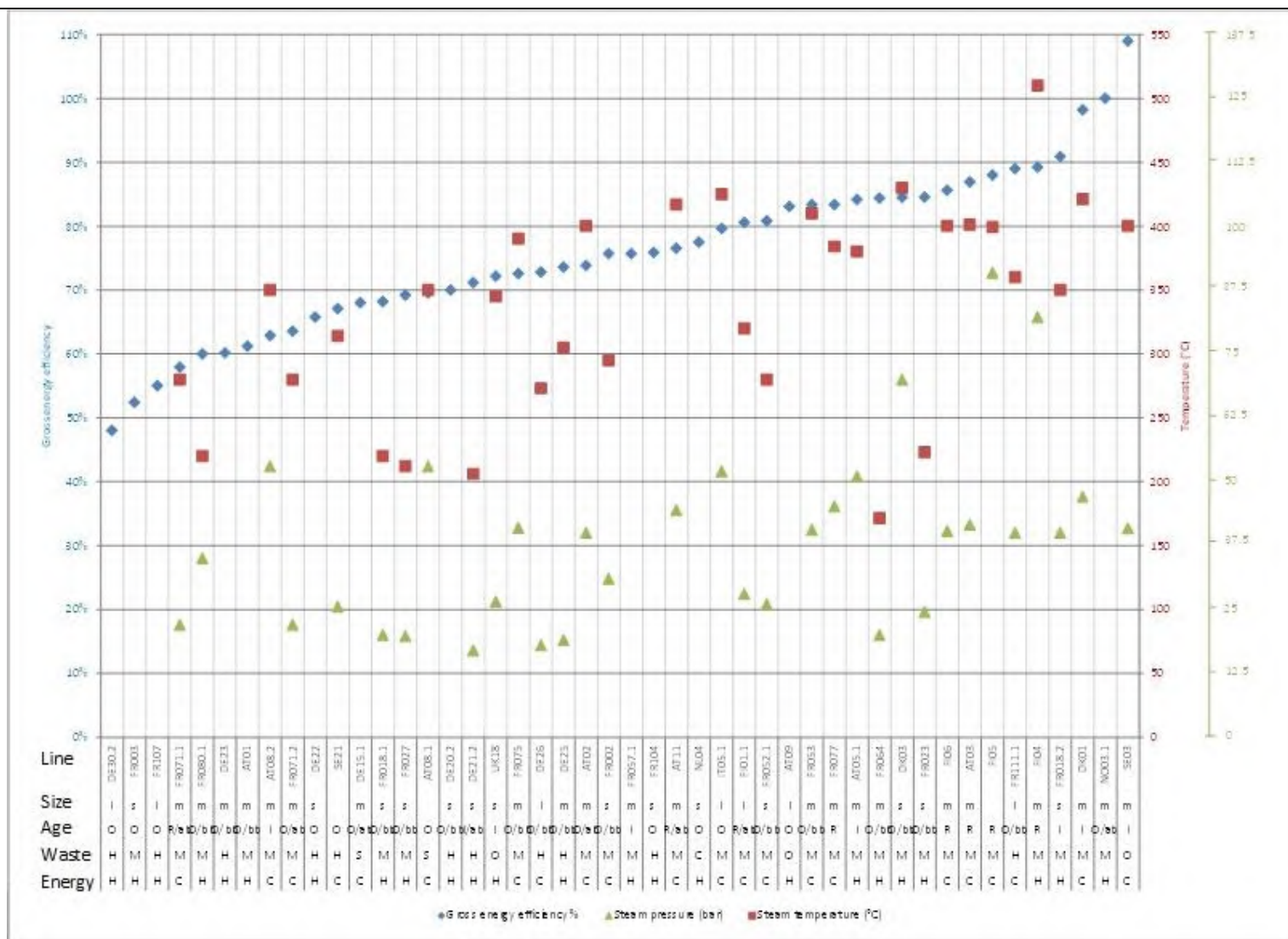

Figure 3.89: Gross electrical efficiency of plants incinerating predominantly municipal solid waste, other non-hazardous waste, and hazardous wood waste (3/3)



NB:
 Plant size: s = small; m = medium; l = large.
 Plant age: O = old; I = intermediate; R = recent // year of retrofitting: bb = before previous WI BREF (2006); ab = after previous WI BREF (2006).
 Prevalent waste burnt: M = municipal solid waste; O = other non-hazardous waste; H = hazardous waste; S = sewage sludge; C = clinical waste.
 Energy production: E = Electricity; H = Heat; C = Combined heat and electricity.
 Source: [81, TWG 2016]

Figure 3.90: Gross energy efficiency of waste incineration plants

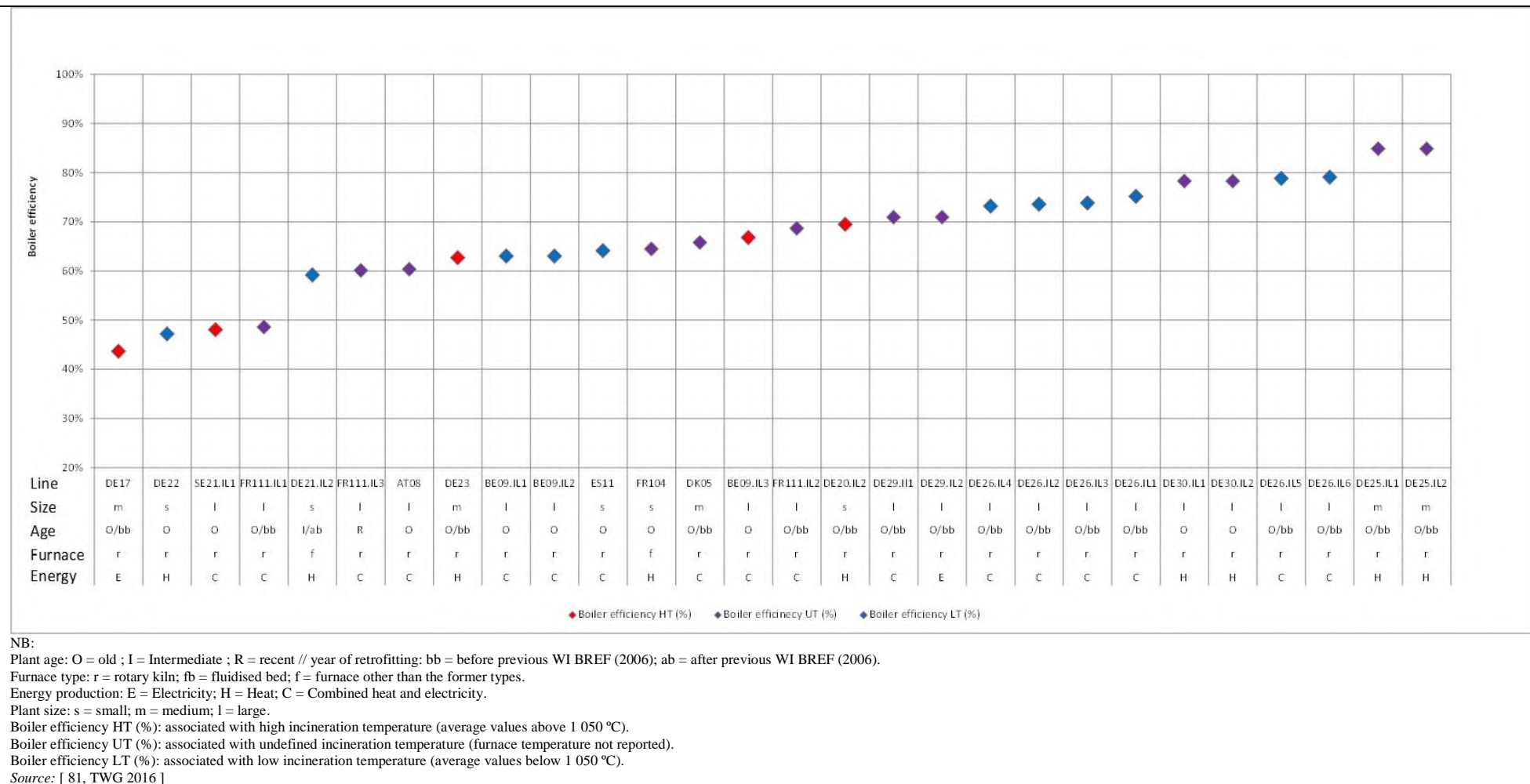

Figure 3.91: Boiler efficiency of plants incinerating predominantly hazardous waste

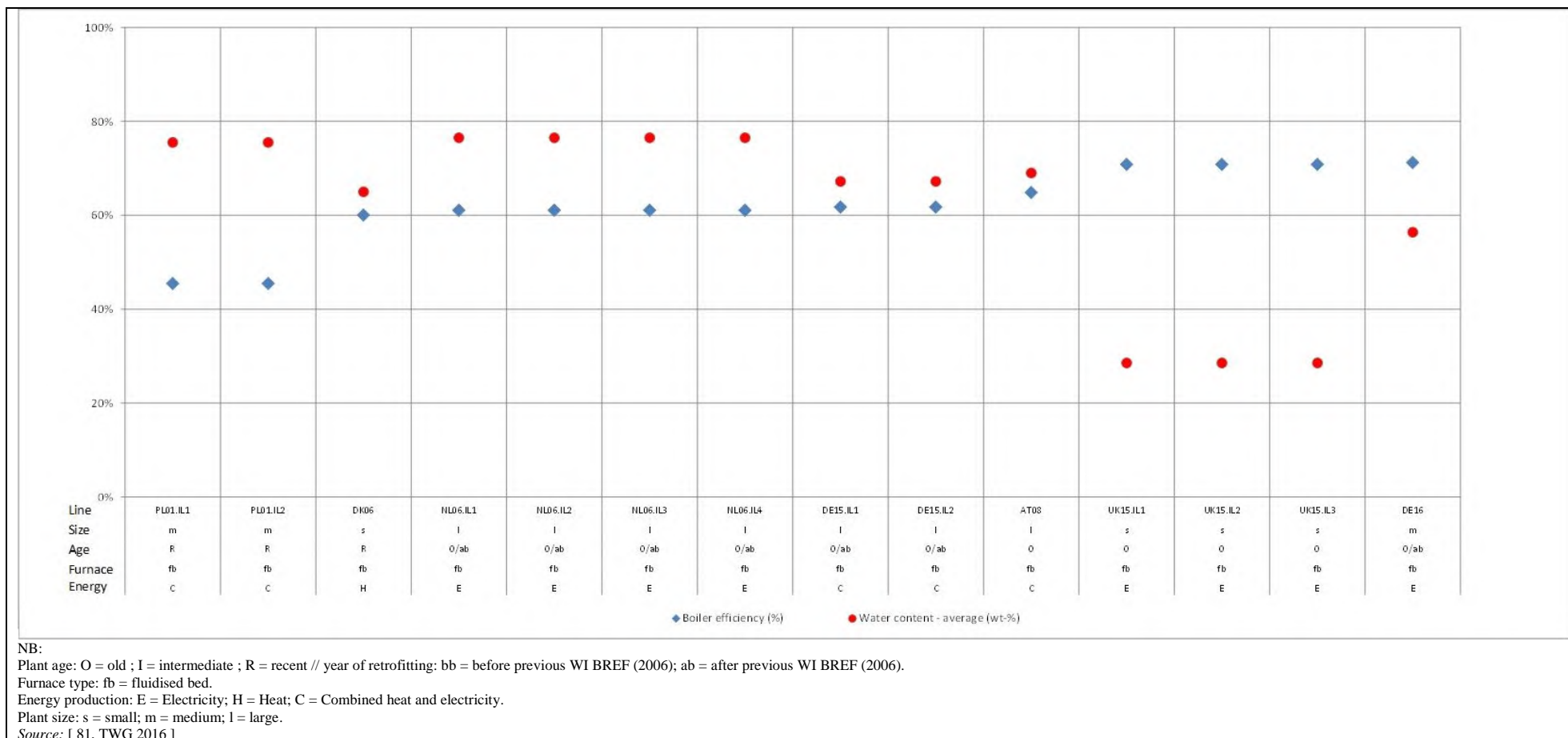

Figure 3.92: Boiler efficiency of plants incinerating predominantly sewage sludge

3.6 Noise

Table 3.38 below describes the sources and levels of noise generated at waste incineration installations, along with some of the reduction measures used.

Table 3.38: Sources of noise at waste incineration plants

Area relevant to noise/ main emitters	Reduction measures	Noise L _{WA} [dB(A)]
Delivery of waste, i.e. noise from lorries, etc.	Tipping hall closed to all sides	104–109
Shredding	Scissors in tipping hall	95–99
Waste bunker	Noise insulation of the building with aerated concrete, tight gates	79–81
Boiler building	Enclosure with multi-shell construction or gas concrete, ventilation channels with connecting link silencers, tight gates	78–91
Machine building	Use of low-noise valves, noise-insulated tubes, noise insulation of the building as described above	82–85
Flue-gas cleaning:		
- ESP	Noise insulation, enclosure of the facility, e.g. with sheets with trapezoidal corrugations, use of blimps for the suction draught and silencer for the chimney	82–85
- Scrubbing		82–85
- Suction draught		82–84
- Chimney		84–85
- Total flue-gas cleaning system		89–95
Disposal of residues:		
- Bottom ash discharge	Enclosure, loading in the bunker	71–72
- Loading		73–78 (day)
- Transportation from the plant		92–96 (day)
- Total waste management residues		92–96 (day) 71–72 (night)
Air cooler	Silencers on the suction and pressure sides (see also ICS BREF for further information)	90–97
Energy transformation facility	Low-noise design, within specially constructed soundproofed building	71–80
Total L_{WA} of the plant		
Day		105–110
Night		93–99

NB: Day/night indicates that the operation is usually carried out during the day or at night.
Source: [1, UBA 2001]

With the noise reduction measures described above, the noise emission limits, given for a specific project based on the local conditions, can be safely met, by day and by night.

Noise is also generated during the construction phase. This may result in considerable noise exposure in neighbouring residential areas, depending mainly on the location. Three main construction stages are all equally relevant as sources of noise:

- digging the excavation;
- laying the foundations (including piledriving); and
- erecting the outer shell of the building.

Appropriate measures, such as restrictions on operating hours, particularly during the night, use of low-noise construction machinery and temporary structural sound insulation measures, may be taken. In some MS, specific legislation also exists for this.

[1, UBA 2001], [2, InfoMil 2002], [64, TWG 2003]

3.7 Other resources used

This section describes some of the substances consumed by the incineration process and gives available data. Table 3.40 at the end of this section provides data regarding the quantities of various substances consumed by hazardous waste incinerators.

3.7.1 Water

The main consumption of water in waste incineration plants is for flue-gas cleaning. Dry systems consume the least water and wet systems generally the most. Semi-wet systems fall in between.

Typical effluent rates at a MSWI are around 250 kg per tonne of waste treated (in the case of wet scrubbing).

It is possible for wet systems to reduce consumption greatly by recirculating treated effluent as a feed for scrubbing water. This can only be performed to a certain degree as salt can build up in the recirculated water. Other uses for the treated effluents are also possible (e.g. cooling of bottom ashes), depending on the water quality requirements of the intended use.

The use of cooled condensing scrubbers provides a further means by which water can be removed from the flue-gas stream, which then, after treatment, can be recirculated to the scrubbers. Salt build-up remains an issue.

Processes without energy recovery boilers may have much higher water consumption. This is because the required flue-gas cooling is carried out using water injection. Consumption rates of up to 3.5 tonnes of water per tonne of waste are seen in such cases. Installations with a rapid quench system (such as those operated in the UK for HWI) may use up to 20 tonnes of water per tonne of waste incinerated.

The water consumption for FGC in HWI is about 1–6 m³ per tonne of waste; and for sewage sludge it is about 15.5 m³ per tonne of waste. However, in dedicated sewage sludge incineration plants using partial pre-drying and incineration in fluidised bed furnaces, around 50 % of the water content of the sludge will evaporate in the furnace; by using a cooling stage after the wet scrubber, it is possible to recover the water from the flue-gases and use it to satisfy the water demand of the scrubber (NL05).

[74, TWG 2004], [7, TWG 2017]

3.7.2 Other consumables and fuels

[1, UBA 2001]

The following consumption (and residual products) rates can be calculated for their **stoichiometric reaction** during flue-gas cleaning.

Table 3.39: Stoichiometric calculation of amounts of various reagents used for absorption during flue-gas cleaning (reactants expressed at 100 % concentration and purity)

Pollutant		Ca(OH) ₂	Residual products	
	kg	kg		kg
HCl	1	1.014	CaCl ₂	1.521
HF	1	1.850	CaF ₂	1.950
SO ₂	1	1.156	CaSO ₄	2.125
Pollutant		NaOH	Residual product	
HCl	1	1.097	NaCl	1.600
HF	1	2.000	NaF	2.100
SO ₂	1	1.249	Na ₂ SO ₄	2.217
Pollutant		Sodium bicarbonate	Residual product	
HCl	1	2.301	NaCl	1.600
HF	1	4.200	NaF	2.100
SO ₂	1	2.625	Na ₂ SO ₄	2.217
Pollutant		Ammonia	Residual product	
NO	1	0.370	Not applicable	
NO ₂	1	0.739		
Pollutant		Urea	Residual product	
NO	1	0.652	Not applicable	
NO ₂	1	1.304		

NB:

- To establish accurate reagent ratios, it is necessary to take into account the initial emission level and the targeted emission level.
- Reactants may be supplied at varying concentrations and this may therefore alter the overall mixed reagent consumption rates.

Source: [1, UBA 2001] [74, TWG 2004]

3.7.2.1 Neutralisers

[1, UBA 2001]

To neutralise the acids contained in the flue-gas, either NaOH, hydrated lime, milk of lime or sodium bicarbonate is used. Its consumption depends on the specific structure of the waste (and hence the raw gas content) as well as the technical equipment used (contact, mixing, etc.).

For hydrated lime, 2 kg to 22 kg are consumed per tonne of waste depending on the type of flue-gas cleaning and other factors. For NaOH, this figure is 7.5–33 kg per tonne of waste.

[74, TWG 2004] [81, TWG 2016]

3.7.2.2 NO_x removal agents

Typical reagents for the removal of NO_x from the flue-gas are ammonia, ammonia water (25 % NH₃) and urea solution. The latter in particular is, depending on the producer, often supplemented by additional ingredients.

If upstream NO_x concentrations are known, this helps achieve a well-controlled process. [74, TWG 2004]

These materials must be used in a targeted manner and well controlled to prevent excessive formation of ammonia or the direct slippage of the excess ammonia.

For ammonia water, a consumption rate of 2 kg to 2.5 kg per tonne of waste is typical. Literature values are in the range of 0.5 kg to 5 kg per tonne of waste.

3.7.2.3 Fuel oil and natural gas

Light fuel oil (diesel), heavy fuel oil (about 1–4 litres per tonne of waste) and natural gas (in Austrian plants between 4.5 m³ and 20 m³ per tonne of waste) are used for process heating and support burners. [74, TWG 2004] [81, TWG 2016]

Waste solvents (typically with a thermal value of > 25 MJ/kg) are also used as support fuels in some plants.

High calorific wastes (e.g. oils and solvents, typically those with a thermal value of > 15 MJ/kg) are routinely used as support fuels in rotary kiln hazardous waste incineration plants.

If the flue-gas is reheated for individual process steps (e.g. SCR), this is mainly done with natural gas.

3.7.2.4 Merchant hazardous waste incinerator plant survey data

[41, EURITS 2002]

An overview is given below of the minimum and the maximum amounts of additives in kilograms per tonne of incinerated waste for surveyed merchant hazardous waste installations.

Table 3.40: Amount of additives used by merchant hazardous waste incineration processes

Additives	kg/t waste		
	Minimum	Maximum	Average
CaO + Ca(OH) ₂ (100 %), as CaO	1.33	97	28.6
NaOH (50 %)	0.40	41.67	15.5
CaCO ₃	11.9	23.76	17.4
HCl (33 %)	0.14	10	1.5
TMT-15 or other sulphide treatment	0.0085	0.98	0.23
Na ₂ S	0.008	0.83	0.44
Na ₂ S ₂ O ₃	0.08	4.2	1.7
FeCl ₃	0.049	0.50	0.27
FeClSO ₄	0.15	0.96	0.55
Fe Al chloride	1.75	1.75	1.75
PE	0.01	1.30	0.3
Activated carbon	0.3	19.31	3.7
Urea (45 %)	3.1	3.1	3.1
NH ₄ OH	0.50	3.33	2.1
CaCl ₂	2.36	2.36	2.36
NB: This table gives only some reference values and may not be representative for a specific installation or technique. Source: [41, EURITS 2002]			

4 TECHNIQUES TO CONSIDER IN THE DETERMINATION OF BAT

This chapter describes techniques (or combinations thereof), and associated monitoring, considered to have the potential for achieving a high level of environmental protection in the activities within the scope of this document. The techniques described will include both the technology used and the way in which the installations are designed, built, maintained, operated and decommissioned.

It covers environmental management systems, as well as process-integrated and end-of-pipe techniques. Waste prevention and management, including waste minimisation and recycling procedures, are also considered, as well as techniques that reduce the consumption of raw materials, water and energy by optimising use and reuse. The techniques described also cover the prevention or limiting of the environmental consequences of accidents and incidents, as well as site remediation. They also cover the prevention or reduction of emissions under other than normal operating conditions (such as start-up and shutdown operations, leaks, malfunctions, momentary stoppages and the definitive cessation of operations).

Annex III to the Directive lists a number of criteria for determining BAT, and the information within this chapter will address these considerations. As far as possible, the standard structure in Table 4.1 is used to outline the information on each technique, to enable a comparison of techniques and the assessment against the definition of BAT in the Directive.

This chapter does not necessarily provide an exhaustive list of techniques that could be applied in the sector. Other techniques may exist, or may be developed, which could be considered in the determination of BAT for an individual installation.

Table 4.1: Information for each technique in this chapter

Headings within the sections
Description
Technical description
Achieved environmental benefits
Environmental performance and operational data
Cross-media effects
Technical considerations relevant to applicability
Economics
Driving force for implementation
Example plants
Reference literature

4.1 Organisational techniques to improve environmental performance

4.1.1 Environmental management systems (EMS)

Description

A formal system to demonstrate compliance with environmental objectives.

Technical description

The Directive defines 'techniques' (under the definition of 'best available techniques') as 'both the technology used and the way in which the installation is designed, built, maintained, operated and decommissioned'.

In this respect, an environmental management system (EMS) is a technique allowing operators of installations to address environmental issues in a systematic and demonstrable way. EMSs are most effective and efficient where they form an inherent part of the overall management and operation of an installation.

An EMS focuses the attention of the operator on the environmental performance of the installation; in particular through the application of clear operating procedures for both normal and other than normal operating conditions, and by setting out the associated lines of responsibility.

All effective EMSs incorporate the concept of continuous improvement, meaning that environmental management is an ongoing process, not a project which eventually comes to an end. There are various process designs, but most EMSs are based on the plan-do-check-act cycle (which is widely used in other company management contexts). The cycle is an iterative dynamic model, where the completion of one cycle flows into the beginning of the next (see Figure 4.1).

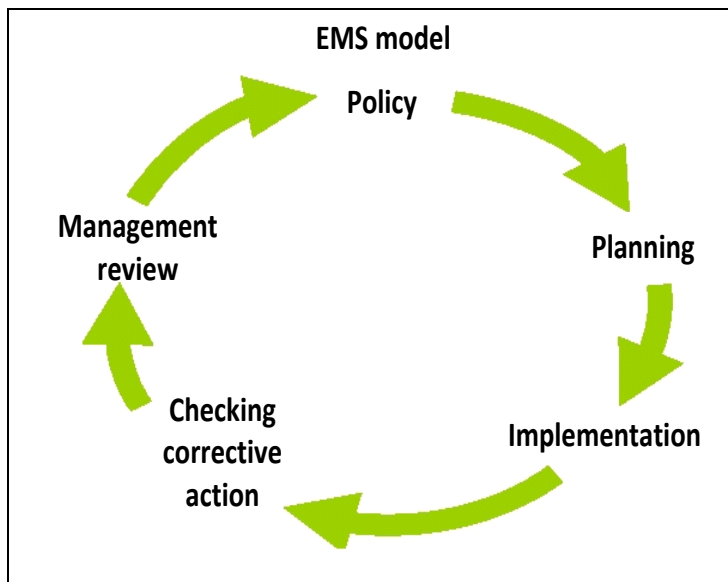

Figure 4.1: Continuous improvement in an EMS model

An EMS can take the form of a standardised or non-standardised ('customised') system. Implementation and adherence to an internationally accepted standardised system, such as EN ISO 14001:2015, can give higher credibility to the EMS especially when subjected to a properly performed external verification. The European Union eco-management and audit scheme (EMAS) according to Regulation (EC) No 1221/2009 provides additional credibility due to the

interaction with the public through the environmental statement and the mechanism to ensure compliance with the applicable environmental legislation. However, non-standardised systems can, in principle, be equally effective provided that they are properly designed and implemented.

While both standardised systems (EN ISO 14001:2015 or EMAS) and non-standardised systems apply in principle to organisations, this document takes a narrower approach, not including all activities of an organisation, e.g. with regard to their products and services, due to the fact that the Directive only regulates installations.

An EMS can contain the following features:

- i. commitment, leadership and accountability of the management, including senior management, for the implementation of an effective EMS;
- ii. an analysis that includes the determination of the organisation's context, the identification of the needs and expectations of interested parties, the identification of characteristics of the installation that are associated with possible risks for the environment (or human health) as well as of the applicable legal requirements relating to the environment;
- iii. development of an environmental policy that includes the continuous improvement of the environmental performance of the installation;
- iv. establishing objectives and performance indicators in relation to significant environmental aspects, including safeguarding compliance with applicable legal requirements;
- v. planning and implementing the necessary procedures and actions (including corrective and preventive actions where needed), to achieve the environmental objectives and avoid environmental risks;
- vi. determination of structures, roles and responsibilities in relation to environmental aspects and objectives and provision of the financial and human resources needed;
- vii. ensuring the necessary competence and awareness of staff whose work may affect the environmental performance of the installation (e.g. by providing information and training);
- viii. internal and external communication;
- ix. fostering employee involvement in good environmental management practices;
- x. establishing and maintaining a management manual and written procedures to control activities with significant environmental impact as well as relevant records;
- xi. effective operational planning and process control;
- xii. implementation of appropriate maintenance programmes;
- xiii. emergency preparedness and response protocols, including the prevention and/or mitigation of the adverse (environmental) impacts of emergency situations;
- xiv. when (re)designing a (new) installation or a part thereof, consideration of its environmental impacts throughout its life, which includes construction, maintenance, operation and decommissioning;
- xv. implementation of a monitoring and measurement programme; if necessary, information can be found in the Reference Report on Monitoring of Emissions to Air and Water from IED Installations;
- xvi. application of sectoral benchmarking on a regular basis;
- xvii. periodic independent (as far as practicable) internal auditing and periodic independent external auditing in order to assess the environmental performance and to determine whether or not the EMS conforms to planned arrangements and has been properly implemented and maintained;
- xviii. evaluation of causes of nonconformities, implementation of corrective actions in response to nonconformities, review of the effectiveness of corrective actions, and determination of whether similar nonconformities exist or could potentially occur;
- xix. periodic review, by senior management, of the EMS and its continuing suitability, adequacy and effectiveness;
- xx. following and taking into account the development of cleaner techniques.

Specifically for incineration plants and IBA treatment plants, the following features can also be incorporated in the EMS:

- xxi. for incineration plants, waste stream management.
- xxii. for bottom ash treatment plants, output quality management.
- xxiii. residues management plan including measures aiming to:
- xxiv. minimise the generation of residues;
 - a) optimise the reuse, regeneration, recycling of, and/or energy recovery from the residues;
 - b) ensure the proper disposal of residues.
- xxv. for incineration plants, OTNOC management plan.
- xxvi. for incineration plants, accident management plan, which identifies hazards posed by the installation and the associated risks and defines measures to address these risks. It considers the inventory of pollutants present or likely to be present which could have environmental consequences if they escape. It can be drawn up using for example FMEA (Failure Mode and Effects Analysis) and/or FMECA (Failure Mode, Effects and Criticality Analysis).

The accident management plan includes the setting up and implementation of a fire prevention, detection and control plan, which is risk-based and includes the use of automatic fire detection and warning systems, and of manual and/or automatic fire intervention and control systems. The fire prevention, detection and control plan is relevant in particular for:

 - o waste storage and pre-treatment areas;
 - o furnace loading areas;
 - o electrical control systems;
 - o bag filters;
 - o fixed adsorption beds.

The accident management plan also includes, in particular in the case of installations where hazardous wastes are received, personnel training programmes regarding:

 - o explosion and fire prevention;
 - o fire extinguishing;
 - o knowledge of chemical risks (labelling, carcinogenic substances, toxicity, corrosion, fire).
- xxvii. for bottom ash treatment plants, diffuse dust emissions management.
- xxviii. odour management plan where odour nuisance at sensitive receptors is expected and/or has been substantiated, including:
 - a) a protocol for conducting odour monitoring in accordance with EN standards (e.g. dynamic olfactometry according to EN 13725 to determine the odour concentration); it may be complemented by measurement/estimation of odour exposure (e.g. according to EN 16841-1 or EN 16841-2) or estimation of odour impact;
 - b) a protocol for response to identified odour incidents, e.g. complaints;
 - c) an odour prevention and reduction programme designed to identify the source(s); to characterise the contributions of the sources; and to implement prevention and/or reduction measures.
- xxix. noise management plan where a noise nuisance at sensitive receptors is expected and/or has been substantiated, including:
 - a) a protocol for conducting noise monitoring;
 - b) a protocol for response to identified noise incidents, e.g. complaints;
 - c) a noise reduction programme designed to identify the source(s), to measure/estimate noise exposure, to characterise the contributions of the source(s) and to implement prevention and/or reduction measures.

Achieved environmental benefits

An EMS promotes and supports the continuous improvement of the environmental performance of the installation. If the installation already has a good overall environmental performance, an EMS helps the operator to maintain the high performance level.

Environmental performance and operational data

No information provided.

Cross-media effects

None reported. The systematic analysis of the initial environmental impacts and scope for improvements in the context of the EMS sets the basis for assessing the best solutions for all environmental media.

Technical considerations relevant to applicability

The components described above can typically be applied to all installations within the scope of this document. The level of detail and the degree of formalisation of the EMS will generally be related to the nature, scale and complexity of the installation, and the range of environmental impacts it may have (determined also by the type and the amount of waste processed).

Economics

It is difficult to accurately determine the costs and economic benefits of introducing and maintaining a good EMS. There are also economic benefits that are the result of using an EMS and these vary widely from sector to sector.

External costs relating to verification of the system can be estimated from guidance issued by the International Accreditation Forum [84, IAF 2010].

Driving force for implementation

The driving forces for the implementation of an EMS include:

- improved environmental performance;
- improved insight into the environmental aspects of the company which can be used to fulfil the environmental requirements of customers, regulatory authorities, banks, insurance companies or other stakeholders (e.g. people living or working in the vicinity of the installation);
- improved basis for decision-making;
- improved motivation of personnel (e.g. managers can have confidence that environmental impacts are controlled and employees can feel that they are working for an environmentally responsible company);
- additional opportunities for operational cost reduction and product quality improvement improved company image;
- reduced liability, insurance and non-compliance costs.

Example plants

EMSs are applied in a number of installations throughout the EU.

Reference literature

[85, COM 2014], [86, EC 2009], [87, COM 2010], [88, CEN 2015], [89, COM 2015]

4.1.2 Ensure continuous operation of the WI plant

Description

The setting up and the implementation of operational procedures (e.g. organisation of the supply chain, continuous rather than batch operation, preventive maintenance) to limit as far as practicable the number of shutdowns and start-ups.

Technical description

Emissions at incineration plants are easier to control during routine operation than during start-up and shutdown operations. Reducing the number of start-ups and shutdowns required is, therefore, an operational strategy that can reduce overall emissions and consumption. Waste collection/delivery regime and seasonal waste generation fluctuations can cause shutdowns through lack of wastes, although they are often avoided by running the plant at partial load in order to deal with such fluctuations. Running at partial load does not normally cause problems for a modern combustor. [74, TWG 2004]

Factors that help to achieve continuous throughput include:

- the process design throughput rate is similar to the rate at which waste is received;
- waste storage (where possible) may cover slow periods;
- organisation of the supply chain to prevent slow periods;
- supplementing waste feed with additional fuels;
- use of online cleaning.

Sizing and maintaining plants to maximise continuous running is, therefore, important.

Good maintenance is important for avoiding/limiting shutdowns. An on-line maintenance programme can be designed for the installation so that availability is maximised.

Achieved environmental benefits

Emissions associated with shutdown and start-up operations are in part avoided. Planning for and achieving a reduced number of shutdowns is likely to reduce the annual mass emission levels of any plant.

Environmental performance and operational data

Predicting and controlling waste flows to the plant is important to ensure the steady operation of the plant.

Cross-media effects

Energy efficiency may be reduced by continuous operation at a lower load, because of the lower turbine efficiency.

Technical considerations relevant to applicability

The technique is generally applicable.

Economics

Avoiding shutdowns can reduce costs at incineration installations by:

- allowing continuous throughput and hence greater installation utilisation;
- decreasing furnace maintenance due to lower thermal stress on the process;
- avoiding the capital costs of an unnecessarily large process.

Where the capacity of the installation is larger than the quantity of the waste received, and the decision is taken to supplement the throughput with other wastes or fuels, there may be costs associated with the purchase of those fuels/wastes.

Driving force for implementation

The main driving forces are operational. Consistent plant operation improves energy efficiency.

Example plants

In general, all waste incineration plants are operated continuously.

Reference literature

[28, FEAD et al. 2002] [64, TWG 2003]

4.2 Operational techniques to improve environmental performance

4.2.1 Quality control of incoming wastes

This section covers those techniques that help the operator to characterise the waste input to be treated. General techniques applied to ensure that the incoming wastes are compatible with the plant characteristics are outlined in the WT BREF and can be referred to for general guidance.

4.2.1.1 Establishment of plant input limitations and identification of key risks

Description

Identification of the types of waste which can be accepted, considering the characteristics of the waste incineration plant, in terms of calorific value, humidity, ash content, physical state, size, etc.

Technical description

Every installation has limitations on the characteristics of the wastes that can be fed to the incinerator itself. With knowledge of the incineration process input limitations, it is possible to derive a waste input specification that highlights the maximum and desirable system input rates. It is then possible to identify the key risks, and the procedural controls required to prevent or reduce operation outside these limitations.

Factors that set such boundaries include:

- design of the waste feed mechanism and the physical suitability of waste received;
- waste flow rate and heat throughput rating of the furnace;
- required environmental performance (i.e. pollutant reduction required expressed as a percentage);
- flue-gas cleaning technology capacity for individual pollutant removal (e.g. limit on flue-gas flow rate, pollutant loading).

Examples of key risks identified can be:

- high mercury input, leading to high raw flue-gas concentrations;
- high iodine or bromine input, leading to high raw flue-gas concentrations;
- high variability in moisture content or CV, leading to combustion irregularities;
- high chlorine loading exceeding FGC capacity;
- high sulphur loading exceeding FGC capacity;
- rapid change in flue-gas chemistry which affects FGC function;
- physically large items blocking feed systems, leading to an interruption of regular operation;
- excessive slagging/fouling of boiler components when certain types of waste are being fed, e.g. high Zn concentration sources (contaminated wood waste) have been reported to cause abnormal slagging in the first boiler pass.

Once the theoretical and actual (i.e. those occurring at plants in operation) risks have been established, the operator can develop a targeted control strategy to reduce those risks, e.g. if experience shows that the HCl emission limit values may be exceeded, then the operator may decide to attempt to control chlorine sources and peak concentrations in the waste fed to the combustion stage and/or to improve the design and operational practice of the acid gas FGC.

Achieved environmental benefits

The use of this technique helps ensure the smooth and stable operation of the incinerator and reduces the requirement for reactive and emergency process intervention.

Environmental performance and operational data

The definition of process input limitations is applied by all waste incineration plants, particularly those that receive wastes from diverse sources and of a wide or difficult-to-control specification (e.g. merchant hazardous waste plants).

Existing plants will have the advantage of experience and knowledge from previous situations encountered during the operational lifetime of the installation. New plants may be able to learn from the operational experience of similar existing plants and then adapt and develop their own procedures according to their specific operational experiences.

Installations with extensive storage and pre-treatment facilities may be able to accept wastes that are initially outside the normal combustor specifications and then treat the waste to meet the combustor requirements.

While merchant HWIs are often built to treat a large variety of hazardous waste, this is not the case for many other installations including MSWIs. However, some types of waste which are similar in nature to MSW are treated in some MSWIs, e.g. commercial waste, some clinical wastes and sewage sludges. The installation may require some adaptation to be suitably equipped to treat wastes that differ in nature from the main type received. This would generally include the provision of adequate reception, storage and handling systems. If the waste is significantly different then more extensive adaptations may also be required, e.g. to the furnace type, FGC, waste water treatment system, specific safety measures and laboratory/testing equipment. [64, TWG 2003]

Cross-media effects

The implementation of process input limitations results in the removal of wastes which fall outside the established specifications. Those wastes are then diverted to other waste treatment options. The type and magnitude of cross-media effects that result are therefore dependent upon the type and performance of the alternative treatment option.

Technical considerations relevant to applicability

The technique is generally applicable.

Economics

Excluding some waste sources/types may reduce income. In addition, specific investment may be required to introduce techniques to identify and manage such wastes, e.g. analysis, pre-treatment.

Driving force for implementation

A good knowledge of process limitations is required in order to assess and select procedures to control input and hence the overall process performance.

Example plants

This is a widely employed practice at hazardous waste incineration plants in particular. The technique is also applied at many European MSWIs in order to identify and possibly exclude undesired waste types.

Reference literature

[55, EIPPCB 2002] [64, TWG 2003]

4.2.1.2 Communication with waste suppliers to improve incoming waste quality control

Description

The quality assurance of the incoming waste

Technical description

Wastes are commonly received from a wide variety of sources over which the operator may have only limited control. Where the operator has identified specific wastes, substances or properties of wastes, or individual sources that can or do cause operational problems, the communication of the operator's concerns to those persons producing and supplying the waste can help to assure quality in the overall chain of waste management. An example is the separate collection of mercury-containing wastes such as batteries or dental amalgam so that the mercury content of the MSW stream is reduced.

The type of techniques used and the degree to which they are employed depend upon the degree of risk and the frequency and nature of any operational difficulties encountered. In general, the greater the variability of the waste types, compositions and sources, the more effort that is required in waste input control.

Achieved environmental benefits

Avoiding the receipt of unsuitable wastes or controlling the delivery of wastes that are difficult to treat or that require special care can reduce operational difficulties and hence avoid additional releases.

Environmental performance and operational data

This technique is of most use at those plants receiving wastes from diverse sources and of a wide, or difficult-to-control, specification (e.g. merchant hazardous waste plants).

Processes that are designed to receive a narrow range of well-defined wastes may need to take particular care to ensure key substances are controlled.

Existing plants will have the advantage of learning from the real situations already encountered. For instance:

- At the SELCHP (South East London, UK) MSWI, sources of gypsum (calcium sulphate) which were disturbing the operation were identified.
- In Caen (France), a successful information campaign to reduce the mercury content in MSW was carried out.

Cross-media effects

Some wastes may need to be diverted from the incinerator to other waste treatment options.

Technical considerations relevant to applicability

The technique is generally applicable.

Economics

Savings may arise from avoiding operational difficulties.

Driving force for implementation

Procedures to control input can reduce the risks of operational upsets and associated releases.

Example plants

This is a widely employed practice at hazardous waste incineration plants in particular.

Reference literature

[64, TWG 2003]

4.2.1.3 Control of waste feed quality on the incinerator site

Description

The control of the waste feed quality on the incineration site.

Technical description

To help control the waste feed quality, and hence stabilise the combustion process within design parameters, a set of quality requirements can be derived for the waste fed to the combustor. The waste quality requirements can be derived from an understanding of the process' operational limitations, such as:

- thermal throughput capacity of the incinerator;
- physical requirements of the feed (particle size);
- controls used for the incineration process (e.g. using LHV, steam production, O₂ content);
- capacity of the flue-gas treatment system and the derived maximum raw gas input concentrations/rates;
- the emission limit values that need to be met;
- bottom ash quality requirements.

Wastes can be stored, mixed or blended (this is restricted by some national legislation) to ensure that the final waste that is fed to the combustor falls within the derived set of quality requirements.

The key substances/properties that will usually require particular procedures to be put in place for their management relate to variations in the concentration and distribution in the waste of the following:

- mercury, alkali metals and heavy metals;
- iodine and bromine;
- chlorine and sulphur;
- variations in heat values / moisture content;
- critical organic pollutants, e.g. PCBs;
- physical consistency of the waste, e.g. sewage sludge;
- mixability of different kinds of waste.

The results of CEN/TC 292 and CEN/TC 343 can be relevant for carrying out the sampling of these substances/properties in the waste (for example, “EN 14899:2005: Characterization of waste - Sampling of waste materials - Framework for the preparation and application of a sampling plan”, or “EN 15002:2015: Characterization of waste - Preparation of test portions from the laboratory sample”).

Achieved environmental benefits

Reduced emissions in the flue-gas through:

- smooth process operation;
- effective combustion;
- improved energy recovery;
- more even raw gas concentrations and hence improved operation of the flue-gas cleaning plant;
- reduced fouling in the boiler by reducing the dust release.

Environmental performance and operational data

All waste incineration plants have their own set of key process input limitations and then adopt suitable receipt restrictions and possible pre-treatment to ensure that these limitations are not exceeded.

This is especially the case where highly variable waste compositions are encountered (e.g. merchant HWIs), and at smaller capacity plants as these have less operational 'buffering' capacity than larger plants.

This technique finds its main application and benefits at hazardous waste incinerators, although in some countries (e.g. Austria) it is performed at every waste incineration plant.

[64, TWG 2003]

Cross-media effects

The preparation and storage of wastes can give rise to fugitive emissions that themselves require management.

Technical considerations relevant to applicability

The technique is generally applicable. Sampling is not applicable to clinical waste due to the risk of infection.

Economics

No information provided.

Driving force for implementation

The driving force is to help ensure that the feedstock material is suited to the processes used, and hence to allow emissions and consumption to be controlled within required parameters.

Example plants

This technique is applied in particular at hazardous waste incineration plants in the EU-28.

Reference literature

[25, Kommunikemi 2002], [64, TWG 2003]

4.2.1.4 Checking, sampling and testing of incoming wastes

Description

The checking, sampling and testing of the incoming wastes.

Technical description

This technique involves the use of a suitable regime for the assessment of incoming waste. The assessments carried out are selected to ensure:

- that the wastes received are within the range suitable for the installation;
- whether the wastes need special handling/storage/treatment/removal for off-site transfer;
- whether the wastes are as described by the supplier (for contractual, operational or legal reasons).

The techniques adopted vary from simple visual assessment to full chemical analysis. The extent of the procedures adopted will depend upon the risk posed by the incoming waste, which in turn will be related to:

- nature and composition of waste;
- heterogeneity of the waste;
- known difficulties with wastes (of a certain type or from a certain source);
- specific sensitivities of the installation concerned (e.g. certain substances known to cause operational difficulties);

- whether the waste is of a known or unknown origin;
- existence or absence of a quality-controlled specification for the waste;
- whether the waste has been dealt with before and experiences with it;
- The main specific techniques applied are listed in Table 4.2.

Table 4.2: Techniques applied for the checking and sampling of various waste types

Waste type	Main techniques applied	Comments
Mixed municipal wastes and other non-hazardous waste	<ul style="list-style-type: none"> • Visual inspection in bunker • Periodic sampling of waste deliveries and analysis of key properties/substances (e.g. calorific value, content of halogens and of metals/metalloids) • For municipal solid waste, spot checking of waste deliveries by separate unloading • Weighing the waste as delivered • Radioactive detection 	Industrial and commercial loads may have elevated risks and require greater attention
Pretreated municipal wastes and RDF	<ul style="list-style-type: none"> • Visual inspection • Periodic sampling and analysis for key properties/substances (e.g. calorific value, content of halogens, POPs and metals/metalloids) 	None
Hazardous wastes other than clinical waste	<ul style="list-style-type: none"> • Visual inspection, as far as technically possible • Control and comparison of data on the declaration list with delivered waste • Sampling/analysis of all bulk tankers and trailers • Risk-based checking of packed waste (e.g. in drums, intermediate bulk containers (IBCs) or smaller packaging) • Unpacking and checking of packaged loads • Assessment of combustion parameters • Blending tests on liquid wastes prior to storage • Control of flashpoint for wastes in the bunker • Screening of waste input for elemental composition 	Extensive and effective procedures are particularly important for this sector. Plants receiving mono-streams may be able to adopt simplified procedures.
Sewage sludges	<ul style="list-style-type: none"> • Weighing of the waste deliveries (or measuring of the flow if the sewage sludge is delivered via pipeline) • Visual inspection, as far as technically possible • Periodic sampling and analysis for key properties/substances (e.g. calorific value, water and mercury content) • Checking for hard materials, e.g. stones/metal/wood/plastics, prior to pumping transportation, dewatering and drying stages • Process control to adapt to sludge variation 	The suitability of the techniques is dependent on the kind of sewage sludge, e.g. raw sludge, digested sludge, oxidised sludge.
Clinical wastes	<ul style="list-style-type: none"> • Control and comparison of data on the declaration list with delivered waste • Screening for radioactivity • Weighing of the waste deliveries • Visual inspection of the packaging integrity 	Infection risk makes sampling inadvisable. Control is required by waste producer.
<i>Source:</i> [1, UBA 2001], [2, InfoMil 2002], [41, EURITS 2002], [64, TWG 2003] [7, TWG 2017]		

Achieved environmental benefits

Advanced identification of unsuitable wastes, substances or properties can reduce operational difficulties and hence avoid additional releases.

Environmental performance and operational data

Examples of tests performed on the incoming waste, depending on the type of waste treated, are shown in Table 4.2.

The most extensive sampling and analysis regimes are used where waste compositions and sources are most variable (e.g. merchant hazardous waste plants) or where there are known difficulties, e.g. a history of problems with a particular waste type or source.

Cross-media effects

No significant cross-media effects.

Technical considerations relevant to applicability

The technique is generally applicable. Sampling is not applicable to clinical waste due to the risk of infection.

Economics

The cost of applying these techniques increases rapidly with the extent and complexity of the procedures adopted.

The costs for the sampling, analysis, storage and additional processing time required can represent a significant proportion of the operational costs at hazardous waste plants in particular, where the most extensive sampling and analysis regimes are applied.

Driving force for implementation

To enable better process control and for plant protection.

Example plants

Widely used throughout the EU-28.

Reference literature

[40, EURITS, 2003] and discussions during site visits. [64, TWG 2003]

4.2.1.5 Detectors for radioactive materials

Description

The use of detectors for radioactive materials.

Technical description

The inclusion of radioactive sources or substances in waste can lead to operational and safety problems. Some wastes are at risk of containing higher levels, particularly those arising from activities that use radioactive materials. Some clinical and industrial wastes may therefore routinely or occasionally contain specific radioactive sources or contamination, although the inclusion of such wastes with municipal waste, and the difficulties of controlling mixed waste collections, can lead to radioactivity in other wastes.

Radioactive materials can often be detected using specific detectors situated at, for example, the entrance to the plant. Tests of waste loads that may have a higher risk of contamination are carried out. Such tests are specifically carried out where loads are accepted on the basis of a maximum level of contamination. Such maximum levels are derived from knowledge of the fate of the isotopes treated, and of the particular process receiving them, and on consideration of the limits set on the contamination levels allowed in releases to land, air and water.

Plastic scintillation detectors are one type of detector used; these measure photons from gamma-emitting radionuclides and to a lesser extent from beta emitters. Radionuclides are regularly detected in clinical waste, laboratory waste and technically enhanced naturally occurring radioactive material. Also important are the controls put in place to prevent the mixing of radioactive waste with regular waste (sometimes done so as to avoid the high treatment cost associated with radioactive waste).

Achieved environmental benefits

Benefits include the prevention of plant contamination and release of radioactive substances. Contamination of the installation can result in lengthy and costly shutdowns for decontamination.

Environmental performance and operational data

Some plants report good experiences of using gate controls for radioactive material, after they recognised that the MSW they receive may occasionally contain radioactive materials.

[64, TWG 2003]

This technique is applied by plants where heterogeneous wastes are received from a wide variety of suppliers. It is applied less when the sources and variability of the waste are well known and controlled, or where the risk of receiving radioactive materials is judged to be low.

Cross-media effects

The main concern is how to manage waste that is identified as radioactive – as neither its transport nor treatment may be permitted. Developing plans and procedures in advance of such situations for managing any radioactive wastes identified is advantageous.

Technical considerations relevant to applicability

The technique is generally applicable.

Economics

In 2006, the investment cost for installing detectors was approximately EUR 25 000–50 000 [122, COM 2006].

Driving force for implementation

Reductions in the tolerable threshold for low-level radioactive contamination encourage the use of the technique. These thresholds may vary from one MS to another according to legislative requirements. [64, TWG 2003]

In some Member States, e.g. France, the regulation on MSWI enforces the implementation of detectors for radioactive materials (with a few exceptions).

Example plants

Hazardous waste and some municipal waste installations.

Reference literature

[40, EURITS, 2003], [64, TWG 2003]

4.2.2 Waste storage

The basic principles of storage outlined in the EFS BREF are applicable to the storage of wastes and can be referred to for general guidance on techniques. General techniques applied in waste storage are also described in the WT BREF. This section concentrates on the specific techniques that are relevant to waste incineration plants, rather than the more general aspects of storage.

4.2.2.1 Sealed surfaces, controlled drainage and weatherproofing

Description

Storage of waste in areas lined with sealed surfaces and fitted with segregated drainage.

Technical description

The storage of wastes in areas that have sealed and resistant surfaces and controlled drainage prevents the release of substances either directly from the waste or by leaching from the waste. The integrity of the impermeable surface is verified periodically.

The techniques employed vary according to the type of waste, its composition and the vulnerability or risk associated with the release of substances from the waste. In general, the following storage techniques are applied.

Table 4.3: Some examples of applied storage techniques for various waste types

Waste type	Storage techniques
All wastes	<ul style="list-style-type: none"> • Odorous materials stored inside with controlled air systems using the discharged air as combustion air (see Section 4.2.2.3) • Designated areas for loading/unloading with controlled drainage • Clearly marked (e.g. colour-coded) areas for drainage from potential areas of contamination (storage/loading/transportation) • Limitation of storage times according to waste type and risks • Adequate storage capacity • Baling or containment of some wastes for temporary storage is possible depending on the waste and location-specific risk factors • Fire protection measures, e.g. fire-resistant wall between the bunker and the furnace hall
Solid municipal and other non-hazardous wastes	<ul style="list-style-type: none"> • Sealed floor bunkers or sealed level storage areas • Covered and walled buildings • Some bulk items with low pollution potential can be stored without special measures
Solid pretreated MSW and RDF	<ul style="list-style-type: none"> • Enclosed hoppers • Sealed floor bunkers or level storage areas • Covered and walled buildings • Wrapped or containerised loads may be suitable for external storage without special measures, depending on the nature of the waste
Bulk liquid wastes and sludges	<ul style="list-style-type: none"> • Attack-resistant banded bulk tanks • Flanges and valves within banded areas • Ducting of tank spaces to the incinerator for volatile substances • Explosion control devices in ducts, etc. • Tank or bunker storage of sewage sludge
Drummed liquid wastes and sludges	<ul style="list-style-type: none"> • Storage under cover • Banded and resistant surfaces
Hazardous waste	<ul style="list-style-type: none"> • Segregated storage according to risk assessment • Special attention to the length of storage times • Automatic handling and loading devices • Cleaning facilities for surfaces and containers
Clinical/Biohazardous wastes	<ul style="list-style-type: none"> • Segregated storage • Refrigerated or freezer storage for biohazardous wastes • Special attention to the reduction of storage times • Automatic handling and loading devices • Incineration of non-reusable waste containers • Disinfection facilities for reusable waste containers • Freezer storage, if the storage period exceeds certain time periods, e.g. 48 hours
<i>Source: [64, TWG 2003]</i>	

Achieved environmental benefits

- Reduction of risk of releases through secure containment.
- Prevention of rainwater penetrating the stored waste (and thus reduction of the LHV and combustion difficulty).
- Prevention of wind scatter.
- Reduction of leachate production (and thus subsequent management requirements).
- Reduction of mobilisation of pollutants.
- Reduction of deterioration of containers (corrosion and sunlight).
- Reduction of temperature-related expansion and contraction of sealed containers.
- Reduction and management of odour releases.
- Management of fugitive releases.

Environmental performance and operational data

The general principle of assessing the waste types received and providing appropriate (i.e. that reduces the spread of contamination and the risk of storage and handling releases) secure storage for them is applied by all installations.

The degree of implementation and precise methods adopted depend upon the wastes received and are outlined above in the Technical description section. In general, liquid wastes and hazardous wastes require the most attention.

Cross-media effects

Increased energy use.

Technical considerations relevant to applicability

The technique is generally applicable.

Economics

No information provided.

Driving force for implementation

- Prevention and reduction of diffuse emissions.
- Optimisation of the incineration process.
- Environmental and health regulation requirements.

Example plants

Widely applied throughout Europe.

Reference literature

[64, TWG 2003]

4.2.2.2 Sufficient storage capacity**Description**

Techniques to consider are a combination of measures to avoid accumulation of waste such as:

- establishing a maximum waste storage capacity taking into account the characteristics of the wastes, e.g. regarding the risk of fire;
- regular monitoring of the quantity of waste stored against the maximum storage capacity;
- establishing a maximum residence time for the wastes that are not mixed during storage.

Technical description

Storage times can be reduced by:

- preventing the volumes of wastes stored from becoming too large;
- controlling and managing deliveries (where possible) by communication with waste suppliers, etc.

Achieved environmental benefits

- Prevention of the deterioration of containers (weathering, ageing, corrosion).
- Prevention of the putrefaction of organic waste (which may otherwise lead to odour releases, processing and handling difficulties, fire and explosion risks).
- Reduction of the risk of labels becoming detached.

Environmental performance and operational data

In general, MSW is stored in enclosed buildings for a period of 4 to 10 days, with the storage periods being strongly influenced by collection/delivery patterns. Because of the desire to run installations on a continuous basis, the storage capacity and hence maximum storage times will often be determined by the maximum amount of time when no waste is likely to be delivered to the plant. Holiday periods in particular can result in several days when no waste is delivered.

[64, TWG 2003]

A limited time for the maturation of municipal waste in the bunker may have a positive effect on the homogeneity of the waste. Feeding fresh waste immediately after it has been delivered may induce fluctuations in the process. [74, TWG 2004]

Where various sources and types of waste are received and added to the furnace to meet a particular feed menu (e.g. hazardous waste installations), longer storage times for particular substances may be beneficial, even of several months in some cases. This allows time for difficult-to-treat wastes to be slowly fed into the system when sufficient compatible materials are also available. Such practices are acceptable where those particular substances are stored in such a manner that the risk of substance and container deterioration is well managed.

Cross-media effects

None reported.

Technical considerations relevant to applicability

The technique is generally applicable.

Economics

No information provided.

Driving force for implementation

Stable plant operation.

Example plants

Widely applied throughout Europe.

Reference literature

[122, COM 2006].

4.2.2.3 Extraction of air from storage areas for odour, dust and diffuse emissions control

Description

Techniques to consider are:

- extraction of the air from waste storage areas and its use as primary and secondary combustion air;
- limiting the amount of waste stored when the incinerator is not available;
- use of an alternative technique to treated the channelled emissions from the storage area when the incinerator is not available.

Technical description

The incinerator air supply (primary or secondary) can be taken from the waste (or chemical) storage areas. By enclosing the waste storage areas and limiting the size of the entrances to the waste storage areas, the whole waste storage area can be maintained under a slight subatmospheric pressure. This reduces the risk of odour releases and ensures that odorous substances are destroyed in the incinerator rather than released.

It is also possible for raw material storage to be ventilated and the air sent to either the combustion chamber or to the flue-gas cleaning equipment, depending on the nature of the air extracted.

The main techniques employed are shown in Table 4.4.

Table 4.4: Main techniques for reducing fugitive diffuse emissions to air, odour releases and GHG emissions

Technique	Application
Solid waste in enclosed buildings from which incineration air is drawn	<ul style="list-style-type: none"> • Municipal wastes • Bulky solid and pasty hazardous wastes • RDF • Sewage sludges • Clinical wastes • Other odorous wastes
Ducting tank vent to incineration air feed	<ul style="list-style-type: none"> • Odorous and volatile hazardous wastes, e.g. solvent wastes • Odorous sludges, e.g. sewage sludge • Other odorous or volatile wastes
<i>Source: [2, InfoMil 2002] p 150, [1, UBA 2001] p 36, [40, EURITS 2003], [7, TWG 2017]</i>	

Achieved environmental benefits

Reduction of diffuse emissions (e.g. odour, dust, CH₄).

Environmental performance and operational data

Typical air requirements for waste incineration processes are 3 000–10 000 m³/tonne of treated waste, depending mainly on the LHV.

If air inlets (e.g. doorways) to waste storage areas are smaller (in terms of their combined total cross-sectional area), the inlet velocity of the air across these inlets will be higher and consequently the risk of diffuse emissions via these routes lower.

Care is required with extraction from hazardous waste (particularly flammable/volatile material) storage areas in order to avoid explosion risks.

In case of fire in the bunker, air channels must be automatically closed to prevent fire jumping from the bunker to the incineration building.

This technique is used where there is a risk of odour or other substances being released from storage areas.

Plants storing volatile solvents can significantly reduce their VOC emissions using the technique.

Cross-media effects

Alternative air handling and treatment (e.g. for odour, VOCs or other substances according to the waste type) measures may be required when the incinerator is not running. Even for multiple line processes where it is usual for at least one line to be running at any particular time, provision of alternative air handling and treatment may be used since it is possible that all lines of a waste incineration plant simultaneously have to stop their operation (e.g. in case of accidents, maintenance of one line and simultaneous breakdown of the other line, end of maintenance when waste is already delivered). [74, TWG 2004]

Technical considerations relevant to applicability

The applicability of limiting the amount of waste when the incinerator is not available may be limited during unplanned shutdowns.

In the case of a risk of explosion, it may be preferable to send the air extracted from the storage area to a separate abatement system instead of using it as incinerator combustion air.

Economics

There are additional ducting costs for retrofits.

The provision of a back-up system for periods when the incinerator is not available entails the additional cost of that system.

Driving force for implementation

- Control of diffuse emissions, including odour.
- Proximity to sensitive odour receptors.

Example plants

The technique is widely used at waste incineration plants throughout Europe. In Germany, up to 60 MSWI plants have long-standing experience with this measure.

Reference literature

[2, InfoMil 2002] p 150, [1, UBA 2001] p 36, [40, EURITS 2003], [64, TWG 2003], [7, TWG 2017]

4.2.2.4 Segregation of waste types for safe processing

Description

Wastes are kept separate depending on their chemical and physical characteristics in order to enable easier and environmentally safer storage and treatment.

Technical description

Waste acceptance procedures and storage depend on the chemical and physical characteristics of the waste. Appropriate waste assessment is an essential element in the selection of storage and input operations.

This technique is strongly related to the checking, sampling and assessment of incoming wastes outlined in Section 4.2.1.4.

The segregation techniques applied vary according to the type of wastes received at the plant, the ability of the plant to treat those wastes, and the availability of specific alternative treatments or incineration pre-treatment. In some cases, particularly for certain reactive mixtures of hazardous wastes, the segregation is required when the materials are packed at the production site, so that they can be packaged, transported, unloaded, stored and handled safely. In these cases, segregation at the incineration installation relates to maintaining the separation of these materials so that hazardous mixtures are avoided. [64, TWG 2003]

Table 4.5: Some segregation techniques applied for various waste types

Waste type	Segregation techniques
Mixed municipal wastes	<ul style="list-style-type: none"> • Segregation is not routinely applied unless various distinct waste streams are received • Bulky items requiring pre-treatment can be segregated • Emergency segregation areas for rejected waste • For fluidised beds, removal of metals may be required to facilitate shredding and prevent blockage
Pretreated municipal wastes and RDF	<ul style="list-style-type: none"> • Segregation not routinely applied • Emergency segregation areas for rejected waste
Hazardous wastes	<ul style="list-style-type: none"> • Extensive procedures required to separate chemically incompatible materials; examples include: <ul style="list-style-type: none"> ○ water from phosphides ○ water from isocyanates ○ water from alkaline metals ○ cyanide from acids ○ flammable materials from oxidising agents • Maintain separation of pre-segregated packed delivered wastes
Sewage sludges	<ul style="list-style-type: none"> • Wastes generally well mixed before delivery to plant • Some industrial streams may be delivered separately and require segregation for blending
Clinical wastes	<ul style="list-style-type: none"> • Moisture content and CV can vary greatly depending on source • Segregate different containers to allow suitable storage and controlled feeding
<i>Source: [2, InfoMil 2002] p 150, [1, UBA 2001] p 36, [40, EURITS 2003], [64, TWG 2003]</i>	

Achieved environmental benefits

Segregating incompatible wastes reduces the risk of emissions by:

- reducing accident risks (that may lead to environmentally and/or health- and safety-relevant releases);
- allowing the balanced feeding of substances, thereby avoiding system overloads and malfunctions and thus preventing plant shutdown.

Environmental performance and operational data

In France, legislation requires the storage of clean containers for clinical waste in a separate room to dirty ones.

Cross-media effects

None identified.

Technical considerations relevant to applicability

The technique is generally applicable.

Economics

No information provided.

Driving force for implementation

The technique is implemented to control the hazards that may arise from the mixing of incompatible materials and to protect the installation by ensuring that the waste fed to the incinerator falls within the range for which the installation is designed.

Example plants

No information provided.

Reference literature

[64, TWG 2003]

4.2.2.5 Use of fire detection and control systems

Description

Techniques to consider are:

- use of an automatic fire detection and warning system;
- use of a manual and/or automatic fire intervention and control system.

Technical description

Automatic fire detection and warning systems are used in waste storage areas as well as for bag and fixed-bed coke filters, electrical and control rooms, and other identified areas of risk.

Continuous automatic measurement of temperature is carried out on the surface of wastes stored in the bunkers. Temperature variations can be used to trigger an acoustic alarm.

Complementary visual control by operators can be an effective fire detection measure.

[74, TWG 2004]

Automatic fire intervention and control systems are applied in some cases, most commonly when storing flammable liquid waste although also in other areas of risk.

Foam and carbon dioxide control systems are used for the storage of flammable liquids. Foam nozzles are commonly used in MSW incineration plants in the waste storage bunker. Water spray systems with monitors, water cannons with the option to use water or foam, and dry powder systems are also used. Nitrogen blanketing may be used in fixed-bed coke filters, bag filters, tank farms, or for the pre-treatment and kiln loading facilities for hazardous wastes.

[74, TWG 2004]

There are also other safety devices, such as:

- nozzles above the waste feed hoppers;
- fire-resistant walls to separate transformers and retention devices under transformers;
- gas detection above the gas distribution module.

When ammonia is used, its storage requires specific safety measures: NH₃ detection and water spray devices to absorb releases. [74, TWG 2004]

The use of nitrogen blanketing requires effective operating procedures and containment to avoid operator exposure. Asphyxiation can occur outside enclosed areas as well as inside.

Achieved environmental benefits

Reduced risk of accidental fugitive releases from fires and explosions.

Environmental performance and operational data

Containment is required to prevent the uncontrolled discharge of polluted firefighting water/chemicals.

Cross-media effects

Consumption of nitrogen for blanketing.

Technical considerations relevant to applicability

The technique is generally applicable.

Economics

Costs are for installation and maintenance and, where used, for nitrogen.

Prevention of damage by fire can result in significant savings. Installation of fire safety measures may reduce insurance premiums.

Driving force for implementation

Safety and safety regulation requirements.

Example plants

Many plants in Europe.

Reference literature

[40, EURITS, 2003], [64, TWG 2003], [74, TWG 2004].

4.2.3 Pre-treatment of incoming waste, waste transfer and loading**4.2.3.1 Pre-treatment, blending and mixing of wastes****Description**

Techniques to consider are:

- mixing of incoming MSW;
- pre-treatment of heterogeneous waste;
- feed equalising control system for solid hazardous waste.

Technical description

Techniques used for waste pre-treatment and mixing are wide-ranging, and may include:

- mixing of liquid or solid hazardous wastes to meet input requirements for the plant;
- shredding, crushing and shearing of packaged wastes and bulky combustible wastes;
- mixing of wastes in a bunker using a grab or other machine;

Mixing of waste may serve the purpose of improving feeding and combustion behaviour. The mixing of hazardous waste with other waste or products, prior to incineration, is done to stabilise the waste feed and process conditions, to increase burnout, to improve safe disposal of residues, and to increase the quality of recovered waste fractions [90 Eurits 2016]. Mixing of hazardous waste can involve risks. Mixing of different waste types may be carried out according to a recipe [74, TWG 2004]

In any case, the mixing of waste prior to incineration should not lead to the dilution of hazardous components which were initially present at a concentration that would not have been acceptable according to the waste incinerator limits [90 Eurits 2016].

Solid heterogeneous wastes (e.g. municipal and packaged hazardous wastes) can benefit from a degree of mixing in the bunker prior to loading into feed mechanisms.

In bunkers, the mixing involves the mixing of wastes using bunker cranes in the storage bunker itself. Crane operators can identify potentially problematic loads (e.g. baled wastes, discrete items that cannot be mixed or will cause loading/feeding problems) and ensure that these are: removed, shredded or directly blended (as appropriate) with other wastes. The technique is commonly applied at municipal plants and other incinerators where batch loads are delivered for pre-incineration storage in a common bunker. Crane capacity must be designed so that it is sufficient to allow mixing and loading at a suitable rate. Usually there are two cranes, each of them sufficient to cope with the blending and feeding of all the incineration lines.

When other wastes are incinerated together with MSW, they may require specific pre-treatment. Clinical waste may be delivered in special packaging, while sewage sludge, when not in a relatively small proportion, may require preliminary partial or total drying, and usually a specific feeding system, e.g. in the feed hopper, in the feed chute, directly in the furnace through a side wall or above the feeder. [74, TWG 2004]

The feed equaliser for solid hazardous waste consists of two screw conveyors capable of crushing and feeding solid waste and a feed hopper for receiving various types of waste. Solid bulk waste is fed to the feed hopper with a grab crane through horizontal feed gates. The feed gates are normally closed to prevent gas leakage into the ambient air.

In the bottom of the feed hopper, there are two hydraulically operated feed screws feeding the waste continuously into the feed chute through fire doors. The fire doors prevent backdraught from starting fires in the feed hopper.

The feed hopper is equipped with a level measurement for the upper and lower fill limits of the hopper. At the upper limit this provides a signal to stop the feed into the hopper while the lower limit signal slows down the operation of the screws so that there will always be some waste left in the buffer zone in the hopper to act as a barrier between the screw and the feed hopper.

The feed hopper thus works as a buffer zone preventing:

- nitrogen from leaking into the kiln; and
- backdraught from causing fire in the feed hoppers.

Drums can be fed through the front wall of the rotary kiln without a feed hopper.

Achieved environmental benefits

The burnability of the waste is improved by making it more homogeneous, thus reducing and stabilising emissions from the furnace, and leading to steadier steam/hot water generation in boilers. Although greater homogeneity generally improves the 'smoothness' of the operation, the degree of treatment suitable for a given waste type depends upon the nature of the waste and the receiving installation's design (i.e. does or will the degree of heterogeneity of the waste lead to particular problems or challenges in the installation, and will the use of additional pre-treatment provide sufficient benefit to outweigh the cross-media effects and costs?).

A homogeneous waste feed results in a more even raw flue-gas composition, which may allow an better optimisation of the flue-gas cleaning process.

Environmental performance and operational data

The safety of waste blending and crushing operations requires consideration when designing such systems and procedures. This is particularly the case for flammable, toxic, odorous and infectious waste packed in drums. Nitrogen blanketing and airlocks for the pre-treatment equipment are effective in reducing risks.

Fires and explosions at mechanical sorting and blending plants are a significant risk. However, blending of MSW in the bunker does not normally cause any particular risk. [74, TWG 2004]

At RMVA Cologne, Germany, the waste is accepted in different fractions and prepared specifically for incineration. The appropriate crushing and removal of valuable materials (primarily metal) and the merging of the individual fractions using conveyors allows the generation of a standardised, homogeneous fuel.

Cross-media effects

Energy consumption and odour, noise and dust emissions from the operation of the pre-treatment equipment can vary widely depending on the nature of the waste, the technique used and the desired feed quality.

Technical considerations relevant to applicability

The technique is generally applicable.

Economics

Costs vary greatly depending on the nature of the waste, the technique used and the desired feed quality.

The cost of separating mixed wastes may be significant. Costs will be reduced where efficient pre-delivery segregation schemes, perhaps coupled with some simple pre-treatment, are already in place, meaning only storage and mixing are carried out at the incineration installation.

The benefits of significant pre-treatment are most likely to be realised at new plants that can design the entire incineration installation for the post-treated waste.

At existing plants that have been specifically constructed to allow for wide feedstock flexibility, and that are already able to achieve good performance levels, the benefits of simple pre-treatment may still be seen. However, the adoption of pre-treatment techniques that effectively require wholesale changes to the waste collection and pre-treatment chain prior to the incineration installation are likely to involve very significant investment in infrastructure and logistics. Such decisions are likely to be beyond the scope of a single installation, and require overall consideration of the entire waste management chain in the region from which wastes are received.

Driving force for implementation

Improved homogeneity of the waste to be incinerated allows better process stability, improved combustion conditions and better process optimisation. Emissions from the incineration installation may therefore be reduced or more closely controlled.

The link to the local waste strategy is important when determining to what extent pre-treatment needs to be carried out.

Example plants

All MSWIs in Europe blend MSW in the bunker. Numerous plants are equipped with a shear, shredder or crusher for bulky objects, e.g. Toulon (FR).

Sewage sludge drying prior to its addition to municipal waste is carried out at a number of plants in Europe, e.g. in Nice-Ariane (FR). It is also carried out without addition, and fed in the feed chute with MSW, e.g. Thiverval (FR), Thumaide (BE), and separately fed into the furnace, e.g. Monaco, Bordeaux Cenon (FR).

[74, TWG 2004]

A feed equalising system is used at Ekokem in Riihimäki (FI), at Sakab in Kumla (SE) and at A.V.R.-Chemie in Rotterdam (NL).

Reference literature

[40, EURITS, 2003], [64, TWG 2003] [90 Eurits 2016], [20, EKOKEM, 2002]

4.2.3.2 Direct injection of liquid and gaseous wastes

Description

The feeding of liquid and gaseous wastes directly to the furnace.

Technical description

To prevent diffuse emissions and to safely handle these wastes, liquid, pasty and gaseous wastes are fed directly to the furnace via several direct feeding lines. In 2002, almost 8.5 % of the total waste incineration in rotary kilns consisted of liquid waste processed through direct injection lines [122 COM 2006]. Each rotary kiln has several direct feeding lines.

In general, the direct injection operation is done by connecting the waste container and the feeding line and pressurising the container with nitrogen or, in the case of sufficiently low viscosity, by emptying the container with pumps. In this way, the liquid waste is fed into the processing line. Depending on the calorific value of the liquid waste, it is injected either into the front of the rotary kiln or into the post-combustion chamber. After processing, the line can be purged with nitrogen, fuel, waste oil or steam.

Multi-purpose and/or dedicated injection lines are used, largely depending on the substances to be incinerated.

Achieved environmental benefits

Prevention of diffuse emissions due to the fact that the waste is fed by a completely closed system.

Environmental performance and operational data

Depending on the characteristics of the liquid wastes, appropriate materials/linings are required for feed lines, with heating required for high-viscosity liquids.

Feed rate capacity ranges depend upon incineration process factors (e.g. thermal capacity and FGC capacity) but can range from 50 kg/h to 1 500 kg/h.

Injection can be via dedicated lance or multi-fuel burner.

Cross-media effects

Use of nitrogen and steam.

Technical considerations relevant to applicability

The technique is generally applicable.

Economics

The average investment price for a dedicated line amounts to EUR 100 000–200 000.

Driving force for implementation

The driving force is the need to feed toxic, odorous, reactive and corrosive liquids and gases safely.

Example plants

Indaver, Antwerp plant (BE), HIM, Biebesheim plant (DE) and GSB, Ebenhausen plant (DE).

Reference literature

[64, TWG 2003]

4.3 Thermal processing

The thermal treatment process used varies depending on the physico-chemical characteristics of the waste burned.

Table 4.6 below provides a comparison of the main applied thermal treatment technologies and factors affecting their applicability and operational suitability. It is important to note that, whilst applied in the sector, the degree of utilisation of the technologies listed varies, as does the nature of the waste to which they have been successfully applied.

Table 4.6: Comparison of combustion and thermal treatment technologies and factors affecting their applicability and operational suitability

Process	Key waste characteristics and suitability	Throughput per line	Operational/Environmental information		Bottom ash quality	Flue-gas volume	Cost information
			Advantages	Disadvantages/limitations of use			
Moving grate – air-cooled	<ul style="list-style-type: none"> Low to medium heat values (LHV 5–16.5 GJ/t) Municipal and other heterogeneous solid wastes Can accept a proportion of sewage sludge and/or medical waste with municipal waste Applied at most modern MSW installations 	1–50 t/h (mostly 5–30 t/h). Most industrial applications not below 2.5 t/h or 3 t/h.	<ul style="list-style-type: none"> Very widely proven on large scales Robust – low maintenance cost Long operational history Can take heterogeneous wastes without special preparation 	Generally not suited to powders, liquids or materials that melt through the grate	TOC 0.5–3 %	4 000–7 000 Nm ³ /t waste input. Depends on the LHV. Typically 5 200 Nm ³ /t.	High capacity reduces specific cost per tonne of waste
Moving grate – liquid-cooled	Same as air-cooled grates except: <ul style="list-style-type: none"> LHV 10–20 GJ/t 	1–50 t/h (mostly 5–30 t/h). Most industrial applications not below 2.5 t/h or 3 t/h	Same as air-cooled grates but: <ul style="list-style-type: none"> higher calorific value waste treatable better combustion control possible 	Same as air-cooled grates but: <ul style="list-style-type: none"> risk of grate-damaging leaks higher complexity 	TOC 0.5–3 %	4 000–7 000 Nm ³ /t waste input. Depends on the LHV. Typically 5 200 Nm ³ /t.	Slightly higher capital cost than air-cooled
Grate plus rotary kiln	Same as other grates except: <ul style="list-style-type: none"> can accept very heterogeneous waste and still achieve effective burnout not widely used 	1–10 t/h	<ul style="list-style-type: none"> Improved burnout of bottom ash possible 	<ul style="list-style-type: none"> Throughput lower than grate only Maintenance of rotary kiln 	TOC 0.5–3 %	4 000–7 000 Nm ³ /t waste input. Depends on the LHV. Typically 5 200 Nm ³ /t.	Higher capital and revenue costs
Static grate with ash/waste transport mechanism	<ul style="list-style-type: none"> Municipal wastes require selection or some shredding Less problems with powders etc. than moving grates 	Generally low < 1 t/h	<ul style="list-style-type: none"> Lower maintenance – no moving parts 	<ul style="list-style-type: none"> Only for selected/pre-treated wastes Lower throughput Some static grates require support fuel 	< 3 % with prepared waste	Slightly lower than other grate systems where staged combustion is used (higher if support fuel used)	Competitive with moving grates on small scales (< 100 kt/yr)
Rotary kiln	<ul style="list-style-type: none"> Can accept liquids and pastes, as well as gases Solid feeds more limited than grate (due to refractory damage) Often applied to hazardous wastes 	< 16 t/h	<ul style="list-style-type: none"> Very well proven Broad range of wastes Good burnout – even of HW 	<ul style="list-style-type: none"> Throughput lower than with grates 	TOC < 3 %	6 000–10 000 m ³ /t waste input	Higher specific cost due to reduced capacity
Rotary kiln (cooled jacket)	Same as rotary kiln but: <ul style="list-style-type: none"> higher CV wastes possible due to greater temperature tolerance 	< 10 t/h	<ul style="list-style-type: none"> Very well proven Can use higher combustion temperatures (if required) Better refractory life than uncooled kiln 	<ul style="list-style-type: none"> Throughput lower than with grates 	Low-leaching vitrified slag	6 000–10 000 m ³ /t waste input	Higher specific cost due to reduced capacity

Process	Key waste characteristics and suitability	Throughput per line	Operational/Environmental information		Bottom ash quality	Flue-gas volume	Cost information
			Advantages	Disadvantages/limitations of use			
Fluidised bed – bubbling	<ul style="list-style-type: none"> Wide range of CV (5–25 MJ/kg) Only finely divided consistent wastes. Limited use for raw MSW Often applied to sludges co-fired with RDF, shredded MSW, sludges, poultry manure 	Up to 25 t/h	<ul style="list-style-type: none"> Good mixing Fly ashes of good leaching quality 	<ul style="list-style-type: none"> Careful operation required to avoid clogging bed Higher fly ash quantities 	TOC < 1 %	Relatively lower than grates	FGC cost may be lower. Costs of waste preparation.
Fluidised bed – rotating	<ul style="list-style-type: none"> Wide range of CV (7–18 MJ/kg) Coarsely shredded MSW may be treated Combined incineration of sludge 	3–22 t/h	<ul style="list-style-type: none"> Good mixing/high turbulence Wide range of LHV High burnout, dry bottom ash 	<ul style="list-style-type: none"> Shredding of MSW required Higher fly ash quantity than grates 	TOC < 3 %, often 0.5–1 %	4 000–6 000 Nm ³ /t	Costs of waste preparation
Fluidised bed – circulating	<ul style="list-style-type: none"> Wide range of CV (6–25 MJ/kg) Only finely divided consistent wastes. Limited use for raw MSW Often applied to sludges co-fired with RDF, coal, wood waste 	Up to 70 t/h	<ul style="list-style-type: none"> Good mixing High steam parameters up to 500 °C easily achievable with heat exchangers in the bed material Greater fuel flexibility than BFB Fly ashes of good leaching quality 	<ul style="list-style-type: none"> Cyclone required to conserve bed material Higher fly ash quantities 	TOC < 1 %	Relatively lower than grates	FGC cost may be lower. Costs of waste preparation.
Static furnace	<ul style="list-style-type: none"> Hazardous liquid and gaseous wastes 	Up to 10 t/h	<ul style="list-style-type: none"> High temperature possible (up to 1 100 °C) Good burnout of liquid and gaseous wastes 	<ul style="list-style-type: none"> Only suitable for liquid and gaseous wastes 	NA	Depending on calorific value and up to 10 000 m ³ /h	NA
Oscillating furnace	<ul style="list-style-type: none"> MSW Heterogeneous wastes 	1–10 t/h	<ul style="list-style-type: none"> Robust – low-maintenance Long history Low NO_x level Low LOI of bottom ash 	<ul style="list-style-type: none"> Higher thermal loss than with grate furnace LHV under 15 GJ/t 	TOC 0.5–3 %	NA	Similar to other technologies
Pulsed hearth	<ul style="list-style-type: none"> Only higher CV waste (LHV > 20 GJ/t) Mainly used for clinical wastes 	< 7 t/h	<ul style="list-style-type: none"> Can deal with liquids and powders 	<ul style="list-style-type: none"> Bed agitation may be lower 	Dependent on waste type	NA	Higher specific cost due to reduced capacity
Stepped and static hearths	<ul style="list-style-type: none"> Only higher CV waste (LHV > 20 GJ/t) Mainly used for clinical wastes 	NA	<ul style="list-style-type: none"> Can deal with liquids and powders 	<ul style="list-style-type: none"> Bed agitation may be lower 	Dependent on waste type	NA	Higher specific cost due to reduced capacity
Spreader-stoker combustor	<ul style="list-style-type: none"> RDF and other particle feeds Poultry manure Wood wastes 	NA	<ul style="list-style-type: none"> Simple grate construction Less sensitive to particle size than FB 	<ul style="list-style-type: none"> Only for well-defined mono-streams 	NA	NA	NA

Process	Key waste characteristics and suitability	Throughput per line	Operational/Environmental information		Bottom ash quality	Flue-gas volume	Cost information
			Advantages	Disadvantages/limitations of use			
Gasification – fixed bed	<ul style="list-style-type: none"> Mixed plastic wastes Other similar consistent streams Gasification less widely used/proven than incineration 	Up to 20 t/h	<ul style="list-style-type: none"> Low leaching residue Good burnout if oxygen blown Syngas available Reduced oxidation of recyclable metals 	<ul style="list-style-type: none"> Limited waste feed Not full combustion High skill level Tar in raw gas Less widely proven 	<ul style="list-style-type: none"> Low-leaching bottom ash Good burnout with oxygen 	Lower than straight combustion	High operating/maintenance costs
Gasification – entrained flow	<ul style="list-style-type: none"> Mixed plastic wastes Other similar consistent streams Not suited to untreated MSW Gasification less widely used/proven than incineration 	Up to 10 t/h	<ul style="list-style-type: none"> Low leaching slag Reduced oxidation of recyclable metals 	<ul style="list-style-type: none"> Limited waste feed Not full combustion High skill level Less widely proven 	Low-leaching slag	Lower than straight combustion	High operating/maintenance costs High pre-treatment costs
Gasification – fluidised bed	<ul style="list-style-type: none"> Mixed plastic wastes Shredded MSW Shredder residues Sludges Metal-rich wastes Other similar consistent streams Gasification less widely used/proven than incineration 	5–20 t/h	<ul style="list-style-type: none"> Can use low reactor temperatures, e.g. for Al recovery Separation of main non-combustibles Can be efficiently combined with ash melting Reduced oxidation of recyclable metals 	<ul style="list-style-type: none"> Limited waste size (< 30 cm) Tar in raw gas Higher UHV raw gas Less widely proven 	<ul style="list-style-type: none"> If combined with ash melting, chamber ash is vitrified Without ash melting chamber: no information available 	Lower than straight combustion	Lower than other gasifiers
Pyrolysis – short drum	<ul style="list-style-type: none"> Pretreated MSW High metal inert streams Shredder residues/plastics Pyrolysis is less widely used/proven than incineration 	~ 5 t/h	<ul style="list-style-type: none"> No oxidation of metals No combustion energy for metals/inert In-reactor acid neutralisation possible Syngas available 	<ul style="list-style-type: none"> Limited wastes Process control and engineering critical High skill level Not widely proven Need market for syngas 	<ul style="list-style-type: none"> Dependent on process temperature Residue produced requires further processing, and sometimes combustion 	Very low due to low excess air required for gas combustion	High pre-treatment, operating and capital costs
Pyrolysis – medium drum		5–10 t/h					

Source: [24, CEFIC, 2002] [2, InfoMil 2002] [10, Juniper 1997] [8, Energos, 2002] [1, UBA 2001] [64, TWG 2003]

4.3.1 Use of flow modelling

Description

The use of flow modelling.

Technical description

Physical and/or computer models can be used to investigate the effects of design features. Various parameters are investigated including gas velocities and temperatures inside the furnace and boiler. The gas flow through FGC systems can also be studied with a view to improving their efficiency, e.g. SCR units.

Computerised Fluid Dynamics (CFD) is an example of a modelling tool that is used to predict gas flows. Using such techniques can assist in the selection of a design that will allow optimisation of the gas flows, so as to encourage effective combustion conditions and avoid long gas residence times in those temperature zones which may otherwise increase the risks of PCDD/F formation. By applying the technique to FGC systems' design, it is used to improve performance, e.g. by ensuring an even flow across the SCR catalyst mesh.

Modelling has been successfully used at both new and existing incineration plants to:

- optimise furnace and boiler geometry;
- optimise the positioning of secondary and/or flue-gas recirculation air (if used);
- optimise the reagent injection points for SNCR NO_x reduction;
- optimise the gas flow through SCR units.

Achieved environmental benefits

The optimisation of the furnace design may enhance the combustion performance and therefore prevent the formation of CO, TOC, PCDD/F and/or NO_x (i.e. combustion-related substances). There is no effect on other pollutants contained in waste. [64, TWG 2003]

Reduction of fouling due to excessive local flue-gas velocities by using CFD modelling can increase the availability of plants and improve the energy recovery over time.

Another benefit is the improved performance of the abatement equipment.

Environmental performance and operational data

The improvement of the flue-gas flow distribution along the boiler helps to reduce erosion and fouling leading to corrosion. The technique is used:

- in new waste incineration projects, to optimise design;
- in existing plants where concerns exist regarding the combustion and boiler design, to allow the operator to investigate and prioritise optimisation possibilities;
- in existing plants undergoing alterations in the furnace/boiler;
- in new and existing plants, to optimise the positioning of secondary/flue-gas recirculation air injection equipment;
- in installations installing or using SCR/SNCR, to optimise the SCR/SNCR unit itself.

Cross-media effects

None reported.

Technical considerations relevant to applicability

The technique is generally applicable to new plants. Only applicable to existing plants during the design of major plant upgrades.

Economics

In 2006, a computer optimisation study cost in the region of EUR 10 000 to EUR 30 000, depending on the scope of the study and the number of modelling runs required.

Savings in investment and operational costs may arise from:

- selection of alternative abatement system technology options;
- smaller/less complex abatement systems;
- lower consumption by the abatement system.

The savings noted above are less likely to be realised where the key design issue for the selection of the abatement system is the presence of heavy metals or halogens, e.g. hazardous waste plants. This is because the driver for FGC system design in these cases is normally the loading of intractable substances rather than combustion-related substances.

Significant costs can be associated with modifying the furnace or boiler design of existing installations.

Driving force for implementation

The driving forces are the optimisation of the combustor design for low raw gas pollutant concentrations and possible reduced emissions and consumption.

Example plants

The technique has been used:

- at the application stage in the UK to demonstrate the effective combustion design of a proposed installation;
- to optimise the combustion-stage design at small municipal plants in Norway;
- when permitting and revising permits in Denmark; recent examples of CFD use from 2017 and 2016 are the Amager Resource Center incinerator in Copenhagen and the Norfors incinerator in Hilleroed;
- for some new and existing municipal plants in Belgium;
- at French plants: Saint-Ouen (1989), Nancy (1995), Toulouse, and St. Germain.

Reference literature

[15, Segers, 2002], [16, Wilts et al. 2017], [17, ONYX, 2000], [64, TWG 2003]

4.3.2 Design to increase turbulence in the secondary combustion area

Description

Design of the secondary combustion chamber to increase the flue-gas turbulence.

Technical description

See also related techniques in Sections 4.3.4 (Primary and secondary air supply and distribution optimisation) and 4.3.6 (Replacement of part of the secondary air with recirculated flue-gas).

This technique relates to design features that increase the turbulence and hence mixing of combustion gases in the area after the primary combustion zone, but before or at the start of the main heat recovery areas when the gas temperatures will generally still exceed approximately 850 °C. After the zone considered here, as the combustion gases may pass onwards through the main heat recovery areas (exchangers), stable and even gas velocity and flow are required to prevent gas counter-flow and circulation that might lead to heat exchange problems and pollutant generation.

In some cases, special configurations of the secondary combustion area can be used to increase turbulence in the secondary combustion chamber. Examples of designs include:

- vortex chambers;
- inclusion of baffles (cooling required);
- several passes and turns in the chamber;
- tangential secondary air input;
- location and position of the secondary air injection systems (nozzles).

The use of additional physical features to increase mixing is currently mainly used for the incineration of hazardous waste.

Achieved environmental benefits

Benefits include improved combustion, leading to lower raw gas concentrations of combustion-related parameters.

This technique can reduce the volume of secondary air required, and hence reduce overall flue-gas volumes and NO_x production. Effective turbulence will also result in improved burnout of combustion gases with reduced VOC and CO levels.

Environmental performance and operational data

No information provided.

Cross-media effects

None identified.

Technical considerations relevant to applicability

The technique is generally applicable.

Economics

No information provided.

Driving force for implementation

No information provided.

Example plants

Hazardous wastes – Cleanaway UK.

Reference literature

[40, EURITS, 2003] [64, TWG 2003]

4.3.3 Selection and use of suitable combustion control systems and parameters

Description

The use of an advanced combustion control system.

Technical description

[2, InfoMil 2002]

The incineration of wastes of variable composition requires a process that can cope with large variations in process conditions. When unfavourable process conditions occur, interventions in operational control are required.

In order to be able to control the incineration process, detailed process information is required, an advanced control system ('philosophy') must be designed, and it is necessary to be able to intervene in the process. The details of the systems used vary from plant to plant. The following provides an overview of process information, control philosophy systems and process interventions that can be used.

Process information may include:

- grate temperatures for various positions;
- thickness of the waste layer on the grate (visual control);
- pressure drop over the grate;
- furnace and flue-gas temperatures at various positions;
- determination of the temperature distribution over the grate surface by optic or infrared measurement systems;
- CO, O₂, CO₂ and/or H₂O measurements (at various positions);
- steam production data (e.g. temperature, pressure);
- openings in the combustion wall for visual observation by individuals or camera;
- length and position of the fire in the furnace;
- emissions data for combustion-related substances (unabated levels).

[74, TWG 2004]

The continuous adaptation of the distribution and amount of incineration air to match the precise incineration reaction requirements in the individual zones of the furnace can improve the incineration process. An infrared camera is an example of a technique that is used to create a thermal image of the burning waste bed. Ultrasound and visual cameras are also used. The temperature distribution on the grate appears on a screen as an isothermal field graduated in coloured areas.

For the subsequent furnace performance control, the characteristic temperatures of the individual grate zones may be determined and passed on to the furnace performance controller as input parameters for furnace variables. Figure 4.2 and Figure 4.3 show, respectively, an example of the components of a furnace control system and of its control parameters. Using fuzzy logic, some variables (e.g. temperature, CO, O₂ content) and a sequence of rules can be determined to maintain the process within these settings. In addition, flue-gas recirculation and tertiary air addition can be controlled.

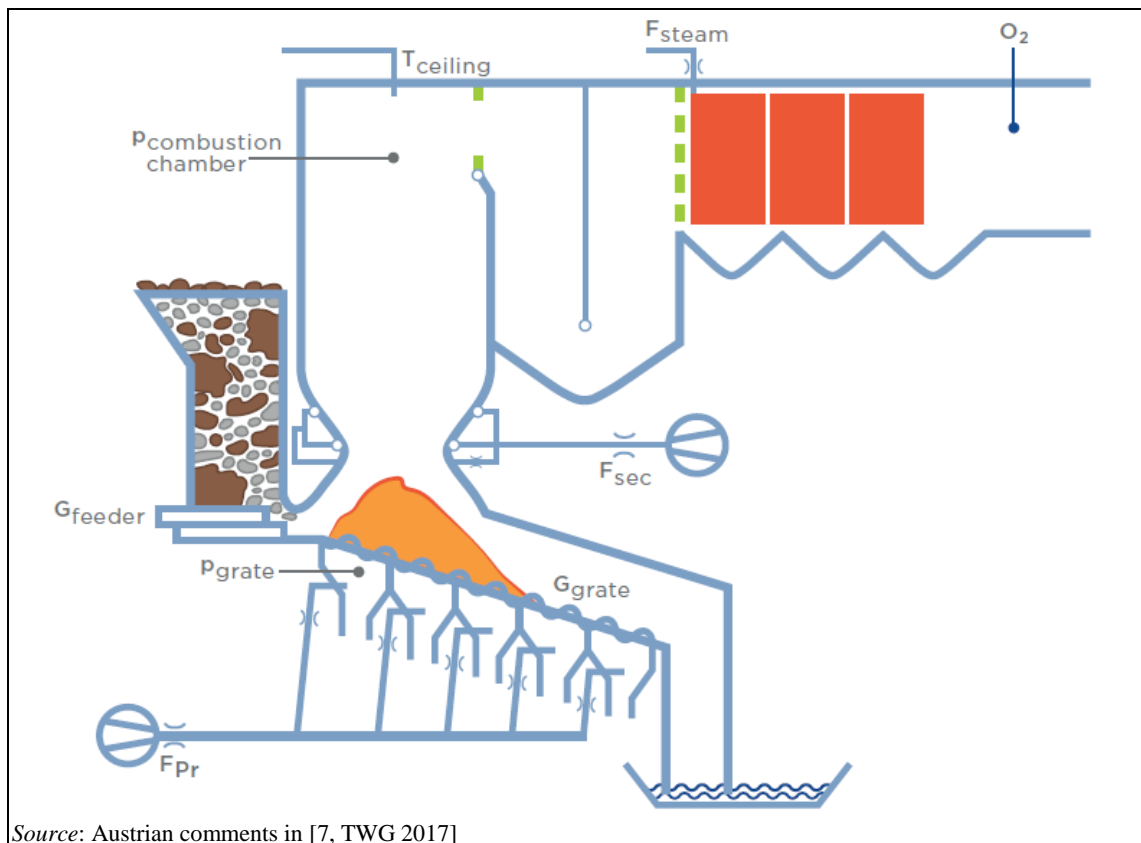

Figure 4.2: Example of the components of a furnace control system

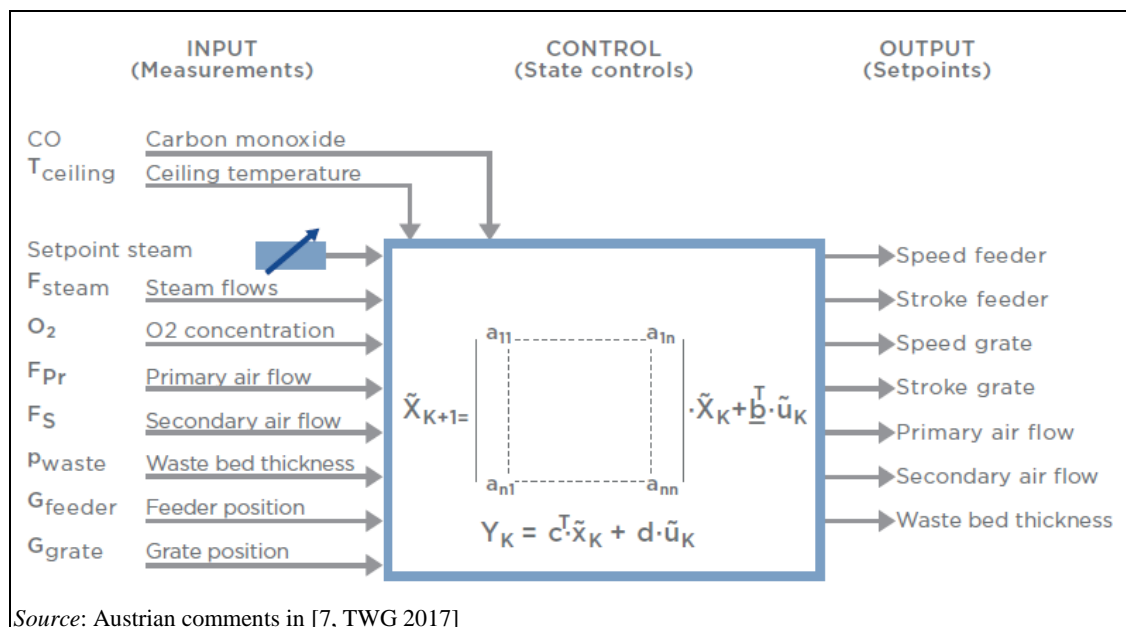

Figure 4.3: Example of the input, control, and output parameters of a furnace control system

By computer-controlled image processing, the video images provided by the IR camera can be transformed into signals which are coupled, in the furnace control system, with parameters such as the oxygen content in the flue-gas and the steam quantity.

The charging of the incineration chamber can then be controlled by recording the average temperature of the waste bed at the front of the grate and evaluation of the O_2 value at the exit of the boiler. With the help of camera-controlled incineration bed temperature recording over the

first three grate zones, primary air can be added according to demand (air quantity and distribution), which helps to even out the incineration process in the main incineration zone. In the grate's ignition zone the air demand is controlled as a function of the incineration bed surface temperature, and a more constant temperature profile may be reached. Adapting the air quantity in the subsequent grate zones, and the temperature of the incineration surface, leads to steady incineration and efficient bottom ash burnout.

The control philosophy can be a classic control system, which may already be included in the process control computer. Additionally, fuzzy control systems are applicable.

Control interventions include adjusting:

- the dosing system for the waste;
- the frequencies and speed of grate movements in various parts of the grate;
- the amount and distribution of primary air;
- the temperature of the primary air (if preheating facilities are available);
- the amount and distribution of secondary air in the furnace (and, if available, of recirculation gas);
- the primary to secondary air ratio.

[74, TWG 2004]

Achieved environmental benefits

The use of advanced control systems can result in an incineration process that has less variations in time (i.e. improved stability) and space (i.e. more homogeneous), thus allowing for an improved overall combustion performance and reduced emissions to all media.

Improved process control has the following specific advantages:

- better bottom ash quality (due to sufficient primary air distribution and a better positioning of the incineration process on the grates);
- less fly ash production (due to less variations in the amount of primary incineration air);
- better fly ash quality (less unburned material, due to more stable process conditions in the furnace);
- less CO and VOC formation (due to more stable process conditions in the furnace, i.e. no 'cold' spots);
- less NO_x formation (due to more stable process conditions in the furnace, i.e. no 'hot' spots);
- less risk of formation of dioxins (and precursors) due to a more stable process in the furnace;
- better utilisation of the capacity (because the loss of thermal capacity due to variations is reduced);
- better energy efficiency (because the average amount of incineration air is reduced);
- better boiler operation (because the temperature is more stable, there are less temperature 'peaks' and thus less risk of corrosion and of clogging fly ash deposits);
- better operation of the flue-gas treatment system (because the amount and the composition of the flue-gases are more stable);
- higher destruction potential, combined with more effective combustion of the waste.

[74, TWG 2004]

The indicated advantages also result in less maintenance and thus better plant availability.

Environmental performance and operational data

In a project, incineration tests were run with oxygen-conditioned primary and secondary air and additions of nitrogen in the secondary air. The use of oxygen-enriched combustion air is discussed in more detail in Section 4.3.7. A decrease of dust, CO and total VOC concentrations in the raw flue-gas was recorded, in particular with oxygenated primary air (O₂ content of supplied enriched air between 25 vol-% and 28 vol-%). Moreover, the NO_x content in the flue-gas could be reduced due to the addition of nitrogen to secondary air.

The results from this investigation have led to the development of a system combining the following process steps:

- fully automatic incineration control through an infrared camera and fuzzy logic;
- flue-gas recirculation to the furnace via a secondary air system; and
- oxygenation of the primary incineration air in the main incineration zones.

Measures introduced at another existing plant with a feed grate included:

- graded addition of incineration air;
- constant dosing of waste through layer height control;
- incineration monitoring by optical sensors (so-called incineration sensors) in different grate zones;
- flue-gas recirculation.

Compared to the plant's conventional operation, the combustion-related pollutants were reduced.

The grate bar temperature may be measured using thermocouples. Flue-gas temperatures are more difficult to measure due to the severe conditions – high level of dust, risk of metal melting, etc. Measurements at the furnace outlet are not easy to implement either due to operational conditions (dust, acid, etc.), in particular for CO and CO₂. For control purposes, quick measurements are required. It is very difficult to measure H₂O accurately. [64, TWG 2003]

The results from the tests with normal operation and with incineration control with the IR camera and with oxygen addition are shown in Table 4.7 below.

Table 4.7: Raw flue-gas measurements at a test plant under normal operation, with IR camera and O₂ conditioning

Flue-gas component (raw flue-gas)	Normal operation	IR camera plus fuzzy logic	O ₂ conditioning
Oxygen content (vol-%)	9.1–9.3	8.9–9.3	6.2–10.9
Carbon monoxide (mg/m ³)	12–32	9–26	20–27
Dust (g/m ³)	0.7–1.7	0.6–1.0	0.5–1.0
Total carbon (mg/m ³)	1.1–2.4	0.9–1.0	1.0–1.2
Dioxins/furans (ng I-TEQ/m ³)	1.5–2.7	1.0–1.3	2.0–3.5
NB: The reported increase in PCDD/F with additional oxygen is not the theoretically expected result. Source: [1, UBA 2001]			

The technique is of particular benefit where the waste fed to the furnace is highly heterogeneous in nature, i.e. of variable composition, or its quality is difficult to predict or assure.

To achieve a stable plant operation, it is also important that the operator of the waste feed systems has a good view of the waste storage and loading areas. This can be achieved by positioning the control room with a view of the combustor loading areas and by the use of video monitors or other imaging systems. [64, TWG 2003]

Cross-media effects

None identified.

Technical considerations relevant to applicability

The technique is generally applicable.

The use of infrared cameras is generally applicable to grate incinerators. This technique is only applicable when the furnace design (in particular the throat) is such that the camera can view the relevant areas of the grate. Moreover, the application is limited, in general, to larger scale furnaces, with several grate lines (e.g. > 10 t/h). [74, TWG 2004]

Economics

The advantages indicated also result in less maintenance and, therefore, better plant availability.

The order of magnitude for one IR camera (not installed and as a stand-alone unit, i.e. not integrated in the control circuit of the plant) was reported in 2004 to be approximately EUR 50 000. However, it is also reported that one supplier quotes EUR 300 000 per line (although it is not clear if this relates to the whole system of IR camera plus O₂ control, etc.) [74, TWG 2004].

The economics of enriching the combustion air with oxygen are discussed in Section 4.3.7.

Driving force for implementation

The improved combustion performance results in overall improvements in environmental performance.

Example plants

Advanced control systems are widely used throughout Europe (e.g. Coburg (DE); Ingolstadt (DE); Fribourg (CH); Brescia (IT); Arnoldstein (AT)). See Section 4.3.7 for examples of oxygen-enriched combustion air use.

Reference literature

[1, UBA 2001], [2, InfoMil 2002], [64, TWG 2003]

4.3.4 Primary and secondary air supply and distribution optimisation

Description

The primary and secondary air flows and distribution are optimised in order to be fed where they are necessary to properly incinerate the waste.

Technical description

Primary air is that which is supplied into, or directly above, the waste bed to provide the oxygen necessary for the combustion. Primary air also helps with the drying and gasifying of waste and with the cooling of some of the combustion equipment.

Secondary air is that which is injected into the flue-gas flows to complete the oxidation of the combustible species in it.

The type of primary air supply is directly related to the incineration technology.

In grate systems, it is supplied through the grate into the waste bed for the following purposes:

- To bring the necessary air to the different zones of the grate where the reactions occur (drying, gasification, volatilisation) and to ensure homogeneous and sufficient distribution inside the waste bed which improves bottom ash burnout.
- To cool down the grate bars to prevent slagging and corrosion. The cooling of fluid-cooled grates is typically achieved by means of a separate water circuit and the effect of the primary air on cooling is therefore irrelevant.

[74, TWG 2004]

In MSWI grates, the primary air flow is determined primarily by the oxygen requirement (a sizing function) and not by the grate cooling requirements. [74, TWG 2004]

Separating the supply of the primary air (using individual wind boxes and, if suitable, multiple or distributed supply fans) to the different zones within a grate incinerator allows the separate control of the air supply to each of the zones. This allows each process that occurs on the grate (drying, pyrolysing, gasification, volatilisation, ashing out) to be optimised by provision of its own optimised air supply.

Insufficient supply of primary air to the final (ashing out) stage can result in poor ash burnout if the residence time in the chamber is not long enough.

In rotary kilns, the primary air is generally introduced above the waste bed.

In fluidised bed systems, the primary air is introduced directly into the fluidisation material and also serves to fluidise the bed itself. The primary air is blown through nozzles from the bottom of the combustion chamber into the bed.

If the combustion air is extracted from waste storage areas, this will help to reduce odour risks from waste storage.

The secondary air flow rate, temperature, number and position of the injection points are optimised to control the flue-gas turbulence, temperature and residence time. Because the mixing of hot gases requires sufficient mixing energy, the secondary air is blown in at a relatively high speed.

The injection point locations, directions and quantities are optimised using computerised flow modelling.

Temperatures at the nozzle heads, where levels of up to 1 300–1 400 °C may be reached, can contribute significantly to NO_x generation. The use of special nozzles and of flue-gas recirculation to replace some of the nitrogen can reduce the nozzle temperatures and nitrogen supply which lead to higher NO_x generation.

The balance of primary and secondary air will depend upon the waste characteristics and upon which of the combustion technologies is utilised. Optimisation of this balance is beneficial for process operation and emissions. In general, higher calorific value wastes allow lower primary air ratios.

Achieved environmental benefits

- Reduction of NO_x, dust, TVOC and CO emissions.
- Reduction of fly ash.
- Improved burnout of bottom ash.
- Reduction in the demand for non-waste fuels to support combustion. [74, TWG 2004]

Environmental performance and operational data

The amount of secondary air used depends on the LHV. [74, TWG 2004]

For grate technology, the amount of secondary air is normally between 20 % and 40 % of the total amount of incineration air, with the remainder being primary air.

There is a risk of rapid corrosion of the water walls of the post-combustion chamber and the boiler, if secondary air is too low, as the CO/CO₂ level could pulse between oxidising and reducing conditions.

Cross-media effects

None reported.

Technical considerations relevant to applicability

The technique is generally applicable.

Economics

Provided the initial design is correct and provides systems and equipment for primary and secondary air control, additional equipment is not normally necessary and therefore no additional costs are incurred. Where intervention is required at an existing plant, additional fans and ducting may be required to control and distribute the air supply.

Reducing the level of NO_x generated can also reduce the operating cost and improve the achievable NO_x abatement level associated with subsequent secondary techniques (SNCR or SCR). The secondary air optimisation might reduce the flue-gas volume and therefore correspondingly reduce the FGC plant size. [64, TWG 2003]

Driving force for implementation

Stable incineration conditions and improved burnout of bottom ash.

Example plants

All the incineration plants.

An example of a retrofit to improve this aspect is Toulon (FR), lines 1 and 2 (2 x 12 t/h), where fans and injection nozzles were changed.

Reference literature

[2, InfoMil 2002], [64, TWG 2003]

4.3.5 Preheating of primary and secondary air

Description

Heat exchangers are used to preheat primary and secondary air, mainly for the incineration of waste with low calorific value. The preheating of primary air is used to dry waste with low calorific value, while the secondary air preheat is beneficial to ensure stable incineration conditions by keeping the temperature of the oxidation zone of the furnace at the design level.

Technical description

Heating the primary air supply can improve the combustion process by drying the waste. This is especially important where low calorific value / high-moisture wastes are burned as they may require additional drying. [2, InfoMil 2002], [64, TWG 2003]

Heating the secondary air supply can improve the efficiency and assist the combustion process in the case of low calorific value wastes by ensuring that temperatures in the gas burnout zone are adequate and evenly distributed.

The preheating of incineration air in grate-type municipal waste incineration plants is normally done with low-pressure steam and not by heat exchange from the flue-gases (due to complicated air ducts and corrosion problems).

The preheating of incineration air for bubbling fluidised bed incineration is normally done with flue-gas by means of heat exchange, but sometimes also with steam or support fuel. [64, TWG 2003]

Incineration air preheating is normally not done in rotary kilns.

In some installations, this heat is taken from the cooling air behind the refractory material.

The heat supplied with the air supply is not lost since it may be recovered later in the boiler. [74, TWG 2004]

Achieved environmental benefits

More stable combustion leads to lower emissions to air.

Upgrading of low-value steam/energy to better quality steam is possible.

Environmental performance and operational data

The heating of primary and, possibly, secondary air is of particular benefit where low calorific value wastes are burned. In the case of primary air, this is because it supports the drying and ignition of the waste; with secondary air, this is because it helps to maintain temperatures in the gas burnout zone.

Primary air is heated to 150 °C by mixing primary air with the cooling air of refractory material in the furnace. [74, TWG 2004]

Cross-media effects

Where heat is taken from the incineration process, the cross-media effects will be minimal. If external fuel sources are used, the consumption of that external energy and the additional emissions (e.g. of NO_x, particulates) are a factor.

Technical considerations relevant to applicability

Plants burning high calorific value waste need the cooling effect of the air supply and will not, therefore, benefit from this technique.

Economics

The design of the system for new plants adds the cost of a heat exchanger plus the steam/condensate circuit. The impact of the additional cost depends on the plant scale.

The capital costs of the heat-exchange equipment can be offset against the savings in support fuels.

Driving force for implementation

Improved combustion performance, especially with low calorific value wastes.

Example plants

Applied at plants throughout Europe.

Reference literature

[2, InfoMil 2002], [64, TWG 2003]

4.3.6 Replacement of part of the secondary air with recirculated flue-gas

Description

The flue-gas is recirculated to optimise the turbulence in the combustion chamber while maintaining the optimal air to waste ratio.

Technical description

One of the purposes of the secondary air addition (apart from oxidising the combustible flue-gas compounds) is to improve the mixing and homogeneity of the flue-gas. However, the use of more secondary air than is necessary results in higher flue-gas quantities. This reduces the energy efficiency of the plant, leading to a need for larger flue-gas treatment units and, therefore, to higher costs.

By replacing part of the secondary air with recirculated flue-gases, the flue-gas volume is reduced downstream of the extraction point and at the point of emission. The reductions in the fresh nitrogen supply (from air) to the furnace may help to reduce NO_x emissions.

In general, the recirculation extraction point is after FGC to reduce corrosion and other operational problems caused by raw flue-gas; this involves some energy losses and the FGC system must be designed for a larger flow.

However, if the flue-gases are recirculated from upstream of the FGC system then the size of the FGC system can be reduced, [64, TWG 2003] although it needs to be set to treat more flue-gases with increased pollutant concentrations and there is a higher risk of erosion, corrosion and fouling. [74, TWG 2004]

See also Section 4.3.4 on secondary air optimisation.

Achieved environmental benefits

- Improved energy efficiency (an increase of approximately 0.75 % was reported at a CHP plant).
- Reduction in NO_x production of 10 % to 30 % (if the raw gas is high in NO_x).
- Reduction in reagent consumption for NO_x control.

Environmental performance and operational data

At high excess air rates, approximately 50 % of the required amount of secondary air can be replaced by recirculating flue-gases. When the recirculated gas is raw flue-gas, this results in a 10–15 % reduction of the total amount of incineration air and flue-gases. The load of the flue-gas treatment system may be reduced proportionally if the concentrated pollutants in the reduced flue-gas quantity can be cleaned in the same way (resulting also in a reduction of emission loads) and the thermal efficiency of the plant may increase by approximately 1–3 %.

Corrosion in the recirculation ducting has been reported. It is also reported that this can be overcome by the elimination of joints, and using effective insulation of ducting to prevent cold spots, where condensation of the flue-gas and corrosion can rapidly occur. Corrosion may also occur in the boiler due to lower oxygen levels in the flue-gas.

[21, FNADE, 2002] The corrosion risk is reduced if the hotter parts of the boiler are covered by special cladding. However, when this cladding is installed, the excess O₂ concentration at the boiler exit can be reduced even without flue-gas recirculation. This, then, reduces the benefit of flue-gas recirculation.

In some German MSWI plants with recirculated flue-gas systems installed, the recirculation is reported to be closed or out of operation for operational reasons. The reduced flue-gas flow is in most cases not considered in the sizing of the FGC plant; many operators choose to size the

FGC plant with the flue-gas recirculation closed, so as to cover all possible operating conditions.

[74, TWG 2004]

Cross-media effects

Depending on the precise furnace design, at high replacement rates the effective reduction of oxygen can result in elevated CO (and other products of incomplete combustion) levels. Care must therefore be taken to ensure that replacement rates are optimised.

There may be a negative cooling effect in the rotary kiln, and in some cases, especially with wastes with lower calorific value, extra fuel is necessary to maintain the rotary kiln temperature.

Technical considerations relevant to applicability

This technique has been applied to new waste incineration plants. Some existing plants have retrofitted this technique, for which space is required for the ducting.

The technique has a limited applicability for HWI. In the case of rotary kiln HWIs, the need for a high O₂ content limits the applicability of flue-gas recirculation. [74, TWG 2004]

Economics

This technique involves additional investments for new plants and significant costs for retrofitting existing plants. [74, TWG 2004]

Driving force for implementation

Reduction of NO_x using primary techniques.

Example plants

Applied at some new and existing plants throughout Europe.

Reference literature

[2, InfoMil 2002], [21, FNADE, 2002], [64, TWG 2003]

4.3.7 Use of oxygen-enriched air

Description

Use of oxygen-enriched air, or technically pure oxygen, as the combustion air.

Technical description

The Arnoldstein municipal waste incinerator, in Austria, operates a process that uses oxygen-enriched air to achieve the integrated sintering of ash in the waste bed of a grate-based waste incinerator. Oxygen enrichment produces higher bed temperatures which melt or sinter 50–80 % of the bottom ash. The unmelted fraction protects the grate from clogging. An infrared camera is used to monitor and control the waste bed temperature by adjusting the under-fire air heating and oxygen enrichment. Reverse-acting grates are used because they maintain a cover of unmelted ash that protects the grate from the higher temperatures employed. The incompletely sintered fraction is separated by a screening and washing process and then recirculated to the combustion process. In addition, 75 % of the fly ashes (boiler ash and first-stage dust removal step ash – not FGC residues from acid gas cleaning) may be recirculated to the combustion stage. The high bed temperatures and wet mechanical treatment of the discharged granulated ash ensure that the fly ash recirculation does not contaminate the granulated product. [91, Austria 2015]

Oxygen-enriched air is also used to burn the gases produced at some gasification and pyrolysis plants. This is often part of systems designed to raise combustion temperatures in order to melt the incinerator ashes. In such cases, the initial pyrolysis or gasification reactor is often a physically separate unit from the subsequent combustion chamber. The fuel-rich syngas passes

into the combustion zone, where the oxygen-enriched air is added at a controlled rate in order to achieve the desired combustion conditions. Depending on the oxygen addition rate and gas quality, temperatures in the combustion chamber are generally between 850 °C and 1 500 °C, although in some specific cases temperatures of up to 2 000 °C (or higher) are used. At temperatures above around 1 250 °C, entrained fly ashes are melted.

Oxygen enrichment has also been applied at small plants that are generally dedicated to the destruction of particular (often hazardous) waste streams. In these smaller plants (e.g. trailer-mountable plants), the process may be applied on a batch basis in a sealed reactor, with elevated pressure (8 bar) and temperatures (e.g. in the range of 2 000 °C to 8 000 °C).

Achieved environmental benefits

The Arnoldstein MWI, Austria, uses oxygen-enriched air to:

- produce a completely sintered, well burned out, low-leaching residue;
- reduce overall plant dioxin discharges (< 5 µg I-TEQ/t of waste input);
- reduce flue-gas volume;
- reduce the volume of fly ashes.

Rapid and efficient combustion can result in very low and controllable CO and other combustion-related emissions.

Environmental performance and operational data

While the replacement of the nitrogen in air with oxygen can reduce the potential for thermal NO_x formation as long as enough nitrogen is substituted, the increased partial oxygen pressure within the reaction zone causes a flame temperature increase that can lead to increased NO_x generation. Care is therefore required to ensure that nitrogen replacement does not result in an overall increase in NO_x.

A lower volume of waste gas is produced compared to air-fed combustion technologies. However, at temperatures above 1 500 °C this benefit may be reduced owing to the thermal expansion of flue-gases. The higher concentration of pollutants that result from the lower flue-gas volume can be treated using smaller FGC equipment. However, such an adaptation would require specific adaptations in the flue-gas treatment at existing plants. Smaller FGC equipment may reduce the raw material consumption to some extent (e.g. NH₃ used in SCR/SNCR for NO_x reduction). However, for pollutants contained in the waste feed, such as Cl₂, the quantity of pollutant produced and hence the consumption of raw materials in the FGC system are proportional to the waste feed rate and increasing the concentration of pollutants in the flue-gas may have little effect on consumption. It is reported that the boiler size may also be reduced using this technique. [74, TWG 2004]

The use of temperatures in excess of 1 500–2 000 °C are reported to have only a limited additional benefit in terms of emissions reduction. [64, TWG 2003]

The MWI at Arnoldstein, Austria has been operating successfully using oxygen-enriched air since 2004. The annual throughput is about 94 000 t/yr, the average oxygen content is about 26 %, and the temperature on the grate is about 1 100–1 200 °C whereas the temperature in the combustion chamber is reduced by means of flue-gas recirculation.

The Arnoldstein incinerator produces a completely sintered, well burned out, low-leaching residue, as shown in Table 4.8.

Table 4.8: Residue quality using enriched combustion air (O₂ at 25–27 %)

	Untreated bottom ash from incineration without O ₂ enrichment	Untreated bottom ash from incineration with O ₂ enrichment	Wet-mechanical treated bottom ash from incineration with O ₂ enrichment
Loss on ignition (%)	2	1	0.1
Leaching of lead (mg/l)	0.2	0.05	0.01
PCDD/F content (ng TEQ/kg)	15	8	0.3
<i>Source: [9], Austria 2015]</i>			

At higher temperatures (above 1 000 °C), furnace and refractory maintenance is generally greatly increased. The higher temperatures used can cause significant material selection and use difficulties. Intensive gas cooling is required to reduce the flue-gas temperature to a suitable level for FGC. Molten fly ash requires systems to ensure its removal (e.g. vortex gas flow) so that it does not come into contact with downstream heat exchangers and cause clogging/erosion.

Additional safety risks result from the production, storage and use of oxygen.

Cross-media effects

- Increased energy consumption for the production of pure oxygen or oxygen-enriched air.
- Reduced resistance of refractory materials and increased corrosion of the boiler.
- Additional crushing required for the separation of metals from the sintered bottom ashes for their subsequent recycling.

Technical considerations relevant to applicability

The technique may not be applicable to existing plants because of the significant design modifications required to the combustion chamber, heat exchange areas, and sizing of FGC systems. At low levels of oxygen addition, the design changes may be more limited, but so too are the potential benefits of the technique.

The technique is applicable to existing plants where:

- combustion-related emissions are high or difficult to control; and
- air supply volumes are already high.

It is also applicable to the incineration of materials that are highly resistant to combustion, e.g. PCBs, because of the high combustion efficiency.

Oxygen enrichment is not widely applied owing to the additional costs and cross-media impacts associated with the generation of oxygen, and the additional operational challenges such as handling molten fly ash.

Economics

Producing pure oxygen is expensive. Oxygen-enriched air is less expensive but still gives rise to additional costs over normal air. The costs may be reduced if the incinerator is on an industrial site where oxygen is already available. Parasitic electrical loads for on-site oxygen generation are significant. This demand varies according to plant size, temperature and oxygen purity requirements but is generally in the order of 0.5–2 MW_e.

At the Arnoldstein MWI, the oxygen enrichment resulted in a 10 % increase in capital costs. This capital cost increase is weighted against a 25% increase of the quantity of waste processed (the flue-gas volume being equal) and a possible reduction in the disposal costs for residues (depending on the legal situation), with income possible from selling the granulated ash residue as an aggregate replacement.

Reductions in the flue-gas volume may reduce the size and cost of the flue-gas treatment devices required.

Driving force for implementation

The technique has been reported to be used for the treatment of some types of hazardous wastes that are otherwise expensive to dispose of.

The technique is reported to have been retrofitted at existing plants that had combustion performance difficulties.

Other driving forces are the reduction in disposal costs for sintered residues because of the low leachability, and the income possible from selling the sintered granulated ash residue as an aggregate replacement.

Example plants

Plant AT06R, a municipal waste incinerator in Arnoldstein (AT), has been successfully operating with oxygen-enriched air since 2004.

Oxygen enrichment is applied in gasification and pyrolysis processes for municipal and industrial wastes in Japan as part of systems that are designed to melt the incinerator ashes (e.g. Asahi Clean Centre, Kawaguchi City, Tokyo).

The first full-scale unit for HW is now operating at SEABO (Municipality of Bologna (IT)). So far it has been used for treating materials such as: hardened paints, halogenated solvents, inks, refinery sludge, plastic packaging, polluted rags, oil containing PCBs, pesticides, and expired medicines, among others.

In Germany, the oxygen enrichment of combustion air is used in Plant DE19R, a liquid and gaseous hazardous waste incinerator operated within a chemical production site at AGV Trostberg.

Reference literature

[18, Italy, 2002], [2, InfoMil 2002], [64, TWG 2003], [91, Austria 2015]

4.3.8 Higher temperature incineration (slagging)

Description

The waste is incinerated at temperatures higher than 1 100 °C to achieve high destruction efficiencies and to produce a vitrified bottom ash.

Technical description

This technique is most commonly applied in Europe to rotary kilns treating hazardous wastes. However, the principle of operating at elevated temperatures can, to some degree, be applied to other furnace types. For example, higher temperatures are sometimes used downstream of fluidised beds receiving non-hazardous wastes (see Section 2.3.4.4).

The incineration temperature rises to 1 100–1 400 °C for a couple of seconds, as all the high calorific value wastes are introduced through the front wall of the kiln. This means that the temperature of the flue-gases remains above 1 050 °C until they pass from the outlet of the secondary combustion chamber. Next, they enter the waste heat boiler and finally flow through the flue-gas cleaning system.

Iron, glass, aluminium and other inorganic solid materials form a molten bottom ash mixture in the rotary kiln. This liquefied ash then flows slowly towards the outlet of the kiln where it falls into a bottom ash quenching basin, positioned under the secondary combustion chamber. Here, the bottom ash is quickly solidified in water. The resulting bottom ash is finely granulated, vitrified and has low leaching characteristics. Due to the granulation effect, the total volume of bottom ash produced is smaller than with conventional incineration.

Achieved environmental benefits

- Organic materials are completely incinerated. The organic matter content in the bottom ash after incineration is typically less than 1 %.
- Lower contents of hydrocarbons and CO in flue-gases.
- Higher destruction of PCBs.

Environmental performance and operational data

Higher temperatures require a good-quality refractory lining. Also, a constant slag layer is needed during the operation. In addition:

- incineration air may require preheating;
- membrane boiler walls have to be protected against the higher temperature with refractory;
- high-temperature corrosion may be a problem;
- molten slag/fly ash may cause operational problems in the furnace and heat-exchange areas.

Low residual hydrocarbons and CO are dependent on the combination of flue-gas mixing (turbulence), residence time and temperature. Homogeneous waste feeding is also considered an important influence. Hence, higher temperature incineration alone is not a guarantee for high gas burnout (i.e. low CO and VOCs). Also, at higher temperatures the gas velocity is higher, thus the residence time is lower. Therefore, to reach the performance level required, the optimisation of all the key parameters is important.

Cross-media effects

- Increased NO_x formation, due to the higher temperatures.
- Increased non-waste fuel consumption where the energy provided by the incineration of waste itself is insufficient to reach the higher incineration temperature.
- Increase of metals in the flue-gas. [40, EURITS, 2003]

Technical considerations relevant to applicability

The technique is mainly applicable to rotary kilns burning hazardous wastes of higher calorific values (overall average typically above 15 MJ/kg), e.g. those that include various solvents and waste oils.

Economics

Additional costs arise from:

- the need to use a water-cooled kiln in order to avoid high maintenance costs;
- the need to use a support fuel to maintain high temperatures;
- the need to modify the furnace to retain heat;
- the need to treat an increased amount of metals in the flue-gas, because their vapour tension increases at higher temperatures.

[74, TWG 2004]

In some cases, the use of higher temperatures has been abandoned on account of the costs associated with refractory maintenance.

Depending on the leaching tests or other local standards applied, the bottom ash produced in high-temperature incineration may be classified as non-hazardous material. This may then reduce the cost of disposal, since the bottom ash may then be transported to a non-hazardous waste landfill (under certain conditions), or even sold for utilisation in road construction. If used for construction, the total content of heavy metals may need to be, and the impact may be judged by comparison with that of other materials used normally for that purpose. [74, TWG 2004]

Driving force for implementation

The technique has been implemented where:

- additional assurance of very high destruction efficiencies is required;
- vitrified bottom ash is required.

Example plants

Ekokem (FI) and Kommunikemi (DK).

Reference literature

[20, EKOKEM, 2002], [64, TWG 2003]

4.3.9 Increase of the waste burnout

Description

Waste burnout is increased using the following techniques:

- turning and agitation of the waste in the furnace;
- use of rotary kilns;
- use of fluidised beds;
- adequate waste residence times in the furnace burnout zone;
- design of the furnace to reflect radiant heat;
- optimisation of primary air distribution and supply;
- addition of other wastes/fuels to support effective combustion;
- size reduction for bigger pieces of waste.

Technical description

Waste fed to the furnace needs to be well mixed and allowed sufficient time to react and ensure that effective burnout is achieved, thereby leaving a residue that is low in organic carbon. In addition, the supply of adequate and well-distributed primary air, which does not result in excessive cooling, will assist this process.

Longer exposure of the waste to elevated temperatures in the combustion chamber, higher bed temperatures and physical agitation of the waste all combine to ensure that ashes produced are low in organic species.

The use of these techniques can result in organic-carbon-in-ash levels of below 1 %.

The level of burnout achievable using any technique will depend upon the characteristics of the waste being incinerated. The waste's physical characteristics will also have a critical influence on the practicality of feeding the waste type to the different designs of combustor, e.g. mixed municipal waste cannot be treated in a fluidised bed without pre-treatment.

Maintaining the process within its thermal throughput capacity also ensures that wastes are properly incinerated and that the residues produced are of a good quality, with possibilities for their use.

Typically, better burnout will be achieved where waste is finely divided and has been homogenised (e.g. by mixing). The pre-treatment of highly heterogeneous wastes can improve burnout.

Achieved environmental benefits

- Effective waste destruction.
- Improved characteristics of the solid residue for possible use.
- Increased energy recovery.

Improving the burnout will lower the residual carbon content and thus the TOC. The TOC is also related to the mobility of metals in the ash. For instance, copper leaches in the form of organo-copper complexes. Improving the burnout will, therefore, also reduce copper leaching.

Environmental performance and operational data

Achieved TOC levels in slags and bottom ashes are in the range of < 1–3 wt-%. In WI plants measuring the loss on ignition, achieved LOI levels are < 1–5 wt-%.

Cross-media effects

Excessive physical agitation of the waste in the furnace can result in higher quantities of unburned material being carried into the secondary combustion chambers. This can result in additional dust and other pollutant loading to the downstream abatement processes. Additionally, excessive agitation can result in more riddlings, i.e. unburnt material passing through the grate. [74, TWG 2004]

An elevation of the combustion temperature, together with the fuel bed temperature, is reported to cause increased formation of CaO in the bottom ash, which increases the pH of the bottom ash. The pH value of fresh bottom ashes often exceeds 12 [38, Vehlow 2002].

This increase in pH may also increase the solubility of amphoteric metals such as lead and zinc, which are present in high quantities in bottom ashes. The pH increase may be critical; in particular, as lead is amphoteric it can be dissolved at pH 11–12 and then be leached. The bottom ash pH may decrease after the incineration phase by ageing.

Technical considerations relevant to applicability

The technique is generally applicable.

Economics

New projects can take account of the need to ensure effective burnout without significant additional costs.

Major reconstruction of combustion chambers at existing plants is expensive. Retrofits may therefore only be possible when a complete refit is planned.

Driving force for implementation

- Environmental legislation requirements.
- Improved waste destruction.
- Improved possibilities for residue use.
- Extraction of the full energetic value from the waste.

Example plants

Applied throughout Europe.

Reference literature

[4, IAWG 1997], [38, Vehlow 2002], [64, TWG 2003]

4.3.10 Reduction of grate riddlings

Description

Grate riddlings are reduced by designing the grate in such a way as to reduce the space between grate bars as much as possible.

Technical description

In grate incinerators, some of the waste may fall through the grate and be partially combusted. These are called 'riddlings'. Attention to grate design, particularly the reduction of spacing between grate bars, can reduce the effect. The quantity and quality of these riddlings depend on the design of the grate, on the interfaces between the moving pieces and with the walls and on the mechanism for keeping them tight. [74, TWG 2004]

Automatic conveyor systems are used to collect these riddlings. The collected material is usually stored for cooling before being reintroduced to the bunker (to avoid fire risk) or sent to the bottom ash extractor.

Achieved environmental benefits

- Improved burnout of the waste.
- Improved ash quality.

Environmental performance and operational data

Storage of the riddlings prior to their reintroduction into the main waste feed is very important to prevent fire risks. Water may be added to ensure that cooling is thorough.

Regular observation is necessary to avoid clogging in the riddlings collection areas under the grates and to avoid safety risks for operators and personnel [74, TWG 2004]

The riddlings of molten, burning drops of some common plastics (found in MSW) like PE and PET can contribute significantly to the total carbon content in ash, to increased COD in the bottom ash and to the significant leaching of copper. All of these parameters are improved by the use of this technique. [64, TWG 2003]

Cross-media effects

Risk of fire when riddlings are in contact with waste.

Technical considerations relevant to applicability

The technique is generally applicable.

Economics

Improving ash burnout quality may reduce disposal costs where the current ash burnout does not meet reuse/disposal requirements without this technique. [74, TWG 2004]

There can be significant investment costs for retrofitting existing plants and extra operational (handling) costs. [74, TWG 2004]

Driving force for implementation

- Improved and thorough waste destruction.
- Improved bottom ash quality.

Example plants

Indaver GF, Beveren (BE).

Reference literature

[64, TWG 2003]

4.3.11 Use of low gas velocities in the furnace and inclusion of empty passes before the boiler convection section**Description**

Techniques to consider are:

- low gas velocity in the furnace;
- empty pass between the furnace and the heat-exchange bundles.

Technical description

The furnaces of waste incinerators are normally designed large enough to provide low gas velocities and long gas residence times. In accordance with the 'three Ts of combustion' principle (sufficiently high time, turbulence and temperature), this allows the combustion gases to be fully burned out, and prevents boiler tube fouling by:

- reducing the fly ash content of the flue-gases;
- allowing the temperature of the flue-gases to be reduced before coming into contact with the heat-exchange bundles.

Heat-exchanger fouling may also be reduced by including empty passes (e.g. water walls without obstructions in the gas path) between the main furnace area and the heat-exchange bundles to allow the gas temperature, and hence fly ash stickiness, to be reduced. Temperatures of below 650 °C before the convective superheater are used to reduce the adhesion of ash to the boiler tubes and thus prevent corrosion. [2, InfoMil 2002], [64, TWG 2003]

Achieved environmental benefits

Benefits include reduced emissions of organic substances from the combustion stage.

Improved heat exchange in boilers owing to a reduction of deposits on boiler tubes can result in improved energy recovery.

Environmental performance and operational data

Reductions in boiler tube deposits results in improved process availability and better heat exchange.

Cross-media effects

No specific effects have been identified, but care may be required to ensure that the secondary air supply or other mechanisms used to support gas mixing are adequate for larger furnaces.

Technical considerations relevant to applicability

The technique is mainly applicable to new plants and where substantial refits of existing furnaces and boilers are being carried out.

Economics

Larger furnaces are more expensive to construct.

Driving force for implementation

- Reduced erosion of the furnace.
- Reduced fly ash production.
- Reduced maintenance.
- Longer boiler lifetime.

Example plants

Commonly applied to MSWIs in Europe.

Reference literature

[2, InfoMil 2002], [64, TWG 2003]

4.3.12 Determination of the calorific value of the waste and its use as a combustion control parameter

Description

The LHV of the waste is determined for the online optimisation of the incineration process. This can be done, for instance, by analysing the process parameters such as the steam production ratio, through a mass balance measuring the flue-gas concentration of CO₂, CO and H₂O.

Technical description

Fluctuations in the characteristics of the waste are more pronounced with some types of wastes (e.g. untreated MSW, some hazardous wastes) meaning that mass and volume are less reliable control parameters. The determination of the LHV on-line may then help to optimise process conditions and improve combustion with such heterogeneous inputs.

Techniques have been developed based upon:

- retrospective analysis of process performance parameters (not a predictive method);
- mass balance calculations based on CO₂, O₂ and H₂O concentrations in the flue-gas (i.e. not a predictive method as based on downstream measurement) and on waste input (averaged values, e.g. using a 'crane' scale) or on other smaller estimated heat flows;
- use of microwave equipment to assess the moisture content of the waste in the feed chute;
- waste colour and dimensions linked to plant output signals by fuzzy logic.

Achieved environmental benefits

Improved combustion control results in reduced emissions from the combustion stage.

Environmental performance and operational data

This technique may be used as a diagnostic tool or (with on-line methods) for process control. Knowledge of the waste's calorific value allows optimisation of the air supply and other critical parameters that control combustion efficiency. With heterogeneous wastes, the mass and volume input rate of the waste can be used as additional control parameters.

Control of the waste features may be part of the delivery contract.

Cross-media effects

None reported.

Technical considerations relevant to applicability

The technique is generally applicable.

Economics

No information provided.

Driving force for implementation

The technique is implemented to improve the combustion and energy recovery performance of the plant.

Example plants

On-line monitoring and assistance systems are used in municipal solid waste incineration plants in the Netherlands and in Germany.

Reference literature

[23, VanKessel, 2002], [64, TWG 2003], [124, Beckmann et al. 2017],
[125, Pohl and Wen 2017]

4.4 Techniques to increase energy recovery

4.4.1 Optimisation of overall energy efficiency and energy recovery

Description

- Optimisation of the installation's energy efficiency and energy recovery.
- Securing of long-term baseload heat/steam supply contracts with large heat/steam users so that a more regular demand for the recovered energy exists and therefore a larger proportion of the energy value of the incinerated waste may be used.
- Location of new installations so that the use of the heat and/or steam generated in the boiler can be maximised through any combination of:
 - a. electricity generation with heat or steam supply (i.e. CHP);
 - b. the supply of heat or steam for use in district heating distribution networks;
 - c. the supply of process steam for various, mainly industrial, uses (see examples in Section 4.3.18).

Technical description

Optimising the efficiency of the plant consists of reducing losses and limiting the process consumption. Increasing the energy output does not, therefore, solely equate to the energy conversion efficiency; it is also necessary to consider the energy required by the process itself and the possibilities for exploitation.

The optimal energy efficiency technique depends, to a certain extent, on the particular location and on operational factors. Examples of factors that need to be taken into account when determining the optimal energy efficiency are as follows:

- Location. The presence of a user/distribution network for the energy provided.
- Demand for the energy recovered. This is a particular issue with heat but generally less of an issue with electricity.
- Variability of demand. Summer/winter heat requirements will vary for example. Plants that export steam as a baseload can achieve a higher annual supply and hence export more of the recovered heat than those with variable output options, which will need to cool away some heat during periods of low demand.
- Climate. In general, heat will be of greater value in colder climates (although the use of heat to drive chilling units can provide options where there is a demand for cooling/air conditioning).
- Local market price for the heat and power produced. A low heat price will result in a shift to electricity generation and vice versa.
- Waste composition. Higher concentrations of corrosive substances (e.g. chlorides) can result in an increased corrosion risk, thus limiting steam parameters (and hence possibilities for electricity generation) if process availability is to be maintained. The composition can also change depending on the season, including for example holiday seasons which cause population changes in some areas.
- Waste variability. Rapid and extensive fluctuations in composition can give rise to fouling and corrosion problems that limit steam pressures and hence electricity generation. Variation in waste composition over the plant life favours the use of a wide spectrum rather than finely optimised design.

[74, TWG 2004]

[28, FEAD, 2002] The optimisation of energy recovery techniques requires the incineration installation to be designed to meet the demand requirements of the energy user. Plants that can supply electricity only will be designed differently to plants than have the opportunity to supply heat or those plants that supply combined heat and power.

Heat only

The energy recovered can be supplied as hot water or steam (at various pressures). The possible consumers are:

- district heating (DH) and cooling (much less common) networks;
- industries, e.g. chemical plants, power plants, desalination plants.

Most of these users require steam, except DH, which can use either steam or hot water. If no steam user is connected to the DH network, hot water can be used as the energy conveyor.

Hot water will often be superheated, typically at a temperature of 200 °C, in order to facilitate the heat transfer in the exchangers.

When the DH uses steam, the steam parameters (pressure and temperature) at the boiler outlet need to be above the highest level required for the DH. In the case of plants supplying heat only, the steam pressure is usually 2 or 3 bar above the DH pressure and the steam is superheated by 2 bar or 30 °C.

Electricity only

Two factors contribute to increasing the TG (turbo-generator) electricity output quantity:

- the high enthalpy of the steam, i.e. its high pressure and high temperature;
- the low enthalpy at the turbine outlet, which results from the steam's low condensation temperature.

This latter temperature depends on the temperature of the cold source (air or water) and on the difference between this and the turbine outlet temperature.

In addition to electricity, hot water can be produced by the use of a heat exchanger after the turbine. [74, TWG 2004]

CHP (Combined heat and power)

CHP generation reduces the loss of energy when the heat demand is low, e.g. in summertime for DH. Efficient electricity generation is enabled by appropriately locating the heat bleed in the thermal cycle, i.e. low-pressure steam is used for the heat supply, leaving higher pressures for electricity generation.

With CHP, when the heat demand is high, the pressure at the outlet of the low-pressure part of the turbine is constant. The pressure depends only on the temperature of the cold DH water (or other return) and variation of the heat demand can be balanced by an accumulator tank or air cooler. [64, TWG 2003]

When the heat demand is not high, the low-pressure section of the turbine must be very flexible because the steam flow inside will vary according to the heat demand. For example:

- from the maximum value: (100 % electricity production, no heat demand) when 100 % of the steam flow is passed to the low-pressure section of the turbine;
- to the minimum value: (maximum heat demand) when only a minimal steam flow is required for turbine protection.

[74, TWG 2004]

In the case of CHP, the bleed on the turbine² is located in such a way that the difference between the saturation temperature at this bleed and the temperature at the DH head will be around 10 °C. This bleed supplying the DH is usually controlled. This means that the pressure is kept constant.

2) In the case of back-pressure turbines (without a low-pressure section), the steam pressure and temperature are those at the outlet of the turbine.

Achieved environmental benefits

Increasing the recovery and effective supply/use of the energy value of the waste replaces the need for the external generation of this energy, resulting both in saved resources and in the avoidance of the emissions and consumption of the avoided external energy generation plant.

Maximisation of the benefit available from the energy value of the waste is often most likely to be achieved in situations where CHP is used, as this can allow *exergy* maximisation. This is because it allows the higher pressure steam to be used for electrical generation while the remaining steam energy (lower pressures) can still be supplied and used as heat. In individual circumstances where CHP supply is not possible, other options may give the optimal solution. [64, TWG 2003]

Environmental performance and operational data

[81, TWG 2016]

In general, about 0.4 MWh to 0.8 MWh of electricity can be generated in a MSW incineration plant from one tonne of MSW, depending on the steam quantity as a function of the waste LHV, the plant size, steam parameters and the steam utilisation efficiency.

For the co-generation of electricity and heat, an additional 1.25 MWh to 1.8 MWh (full-load hours) of heat per tonne of waste can be supplied, depending on the LHV of the waste, but at the cost of reduced electricity generation. Site-dependent heat supply opportunities are very significant in such cases. These depend on a number of factors including:

- geographical location;
- normal (district) heat utilisation periods (e.g. in Germany 1 300–1 500 h/yr, while in Denmark, where the large size of the DH networks enables the year-round supply of the whole heat production, this reaches 4 000–8 760 h/yr; the heat utilisation period may be extended by supplying chilled water or steam/heat for industrial purposes).

Concerning heat, under favourable conditions, energy supplied after the boiler (as hot water or steam) can be increased to about 90 % of the total energy input to the boiler (not including internal consumption requirements) for an incineration plant operated at baseload. Where a high conversion efficiency and baseload demand are available (i.e. special arrangements made to create such circumstances), with specially prepared high calorific value wastes (in excess of 20 MJ/kg) it is possible to recover a total of 4–5.5 MWh of heat per tonne of waste [45, FEAD 2002]. Such output levels are not achievable with lower calorific value wastes, e.g. untreated MSW – which generally has a LHV between 8 MJ/kg and 12 MJ/kg.

Cross-media effects

The recovery of energy should not impede the safe and effective destruction of the waste. For example, high steam conditions may compromise plant availability. Higher energy efficiency leads to higher investment and maintenance costs and may also lead to lower availability. [74, TWG 2004]

Particular attention must be paid to boiler design in the temperature range of 450–200 °C to ensure dioxin reformation is minimised, e.g. prevention of dust retention in such zones (see Section 4.4.14).

Certain pollution control and general techniques have a high energy demand. Some examples of significant energy demand techniques include:

- bag filter: it reduces dust (and other) emissions; multiple filters in series further increase the demand for energy;
- SCR: it reduces NO_x and gaseous PCDD/F emissions but, as a tail-end FGC system, SCR requires energy for flue-gas heating;
- HCl or NaCl regeneration: external evaporation of effluent;
- plume reheat: reduces plume visibility;
- ash melting: improvement of ash quality.

The energy demand of the waste incineration plant itself is in the range of 2–5 % of the thermal output (for grate firing or rotary kilns) and 4–10 % in the case of fluidised beds. [74, TWG 2004]

Technical considerations relevant to applicability

The efficiency range that can be achieved depends significantly on the chemical and physical nature of the waste being burnt (i.e. MSW, HW, SS, etc.) as well as its calorific content. In general, higher electrical efficiencies can be achieved where the waste contains lower and/or less variable concentrations of substances that may enhance corrosion in boilers. As high-temperature corrosion becomes an increasing problem at higher steam parameters, the need for high plant availability can become a limiting factor.

[29, Energy subgroup, 2002] Often, when recovered energy is used as heat, a part of the heat supplied is not actually used. In some cases, the losses from the system which is supplied with the heat may be significant because the demand is not constantly at full load. Typically the recovered heat may be maximised in situations when:

- the consumer is an industry with a demand for all the energy recovered;
- waste can be stored and then burned when heat is required (this avoids wasting fuel energy);
- the needs of the district heating network are greater than the energy supplied by the WI plant.

The last case is most commonly found in cities or other locations with extensive district heating networks.

Where a suitable heat distribution and use network is not available, this will limit the opportunities and rationale for achieving high levels of heat recovery and hence limit the ability of the process to export all of the available energy, thus making the highest levels of efficiency difficult to reach.

The choice of the site where the plant will be built and the European (climate) zone where it is located (e.g. colder climates are advantageous for heat export) are therefore critical in determining the available energy outlets, and hence the attainable efficiency.

Opportunities for increasing the overall energy recovery from new WI plants can therefore be seen to be greatest at the time when the location of new plants is being selected. The decision to locate a plant so that it may be economically connected to a suitable energy distribution network will generally have a much greater influence on overall energy recovery than the technological choices made in the operating plant.

Decreasing the installation's energy demand may involve decisions regarding the type and extent of FGC system used. A balanced approach to such decisions is appropriate, i.e. one that takes account of the general desire to reduce the installation's energy requirements and the degree to which pollutants should be abated.

Economics

The prices paid for supplied electricity and heat have a major influence on the economics of investments made to increase these outputs. In some cases, subsidies are paid that provide very attractive prices for electricity production. In other cases, a high demand for heat can result in favourable prices for heat. In such cases, the income to be derived from these sources can make capital investments to increase output more favourable.

For plants supplying electricity only, increasing electrical efficiencies induces higher revenues from the additional electricity generated/sold but also involves higher investment costs and often higher maintenance costs. Therefore the price of the (sold) kWh will play a key role in the choice of a solution. [74, TWG 2004]

For CHP plants, the larger the quantity of energy exported as heat, the smaller the benefit from the improved efficiency of the electricity generation. [74, TWG 2004]

Driving force for implementation

The main driving forces for increased energy efficiency are favourable economic conditions. These in turn are affected by factors such as:

- climate;
- location;
- prices for heat and power.

Higher income from energy sales can, in particular, allow the following:

- Increases to be made in electrical export efficiency to between 20 % and 30 % (e.g. 0.6–0.9 MWh/tonne for an untreated mixed MSW of 2.9 MWh/t). The higher levels are achieved through the use of waste pre-treatment systems (note that pre-treatment stages often require energy and may even negate the increased efficiency at the incineration stage on an overall system perspective) including RDF production for fluidised bed combustion, and increased steam parameters beyond 40 bar and 400 °C.
- Investment in heat or steam supply networks to increase the ability to use the available energy, to give efficiencies in the order of 80 % to 90 % (e.g. > 2.3 MWh/tonne for an untreated mixed MSW of 2.9 MWh/t) where there is a year-round heat demand.
- Investment in techniques to capture the available heat from low-temperature sources that might otherwise not be economical, e.g. condensing scrubbers and heat pumps (see Sections 4.4.11 and 4.4.12).

In terms of optimising the energy recovery, reducing the technical risk and reducing costs, heat supply is favourable where this is possible. However, this still depends on the local conditions, and significantly on the sale prices of electricity and heat. If a (substantial) part of the heat cannot be used, then CHP may well be the right solution. If no heat can be sold, then good practice is generally to use the available energy to generate electricity.

Heat only

The client demand is the key driving force. Therefore location is of great importance.

An important factor is the duration of the contract to receive heat. Often industrial clients cannot commit themselves for more than one or two years. This does not fit well with incineration plants, where a project can require several years before the plant even starts; and incineration plants' financing and operation is usually long term (15–25 years).

The most favourable situation is when all the recovered heat can be sold for heat use. This may occur with industrial customers or with DH either in colder climates or for very large DH networks with a baseload higher than the plant output³.

Where all the recoverable heat cannot be sold, the aim is then to try to use the remaining energy for generating electricity. The decision depends on the remaining quantity of energy and on the capital investment and income costs to be derived from electricity sales.

Electricity only

If there is no customer for the heat, the only option is to generate electricity. Increasing the electrical output can be achieved by using increased steam parameters (see Section 4.4.5). The

3) Some plants that report 100 % export of the heat that they recover actually supply steam to another company which then turns it into electricity, e.g. Brussels, Belgium; Metz, France; Vancouver, Canada. Among eight German plants selling heat only, all the plants which sell a high quantity of heat per tonne of waste supply their heat directly to a power station and, usually, exclusively as process steam.

choice of the steam parameters (high or low) is most commonly taken on an economics basis. The technological risk is also a factor as this increases where higher steam parameters are used (e.g. above 40 bar and 400 °C for mixed municipal waste), and, if not well managed and maintained, the plant may then experience losses of availability.

CHP

Generally CHP provides a solution for increasing the overall energy output when only part of the heat can be sold. CHP is especially effective if the temperature of the required heat is low.

Example plants

Municipal waste incineration plants:

- Avfallskraftvärmeverket Renova, Gothenburg (SE06) and Umeå Energi AB, Umeå (SE02) – high levels of internal energy integration with a view to maximising heat supply to local networks.
- Kymijärvi II, Lahti (FI03) and Rüdersdorf (DE84) – high steam parameters and electrical output.
- Indaver, Beveren (BE07) – supply of process steam directly to neighbouring industry.
- UVE (unité de valorisation énergétique des déchets), Metz (FR57), receives demineralised water from a nearby industry, converts it to steam and exports it back to the industry for heat or electricity production depending on the industry's need.

Examples of MSWI plants generating hot water for district heating:

Rungis (FR64), La Rochelle (FR23), Laanila WtE Plant, Oulu (FI04), Vantaan Jätevoimala, Vantaa (FI05), Westenergy Oy Ab, Mustasaari (FI06), MVA Pfaffenau, Vienna (AT03).

Examples of plants providing steam for district heating:

Biomasseheizkraftwerk Zolling GmbH, Zolling (DE04), Allington Incinerator, Maidstone (UK07), Waste-to-Energy Plant HVC Dordrecht (NL03).

Examples of plants providing steam to industry:

Nantes-West (FR).

Examples of plants generating electricity only:

London (UK 09.1), MVA Zistersdorf, Zistersdorf (AT07).

Examples of MSWI plants providing steam to electricity generation installations:

Brussels (BE); several examples in Germany; Vancouver (Canada).

Examples of hazardous waste incineration plants:

- BASF Ludwigshafen, Ludwigshafen (DE26), SAV Biebesheim, Biebesheim (DE29), and SEDIBEX, Sandouville (FR111) – electricity generation and heat supply;
- Fos/MER (FR104) – the steam produced is entirely used at the chemical site;
- German chemical industry (19 plants, capacity > 500 000 t/yr) with on-site use of steam for other processes, electricity (4 plants) and additional district heating;
- AGV, Trostberg (DE19) – energy recovery by heating thermal oil for further use in chemical production;
- SAV Hamburg, (DE30) – steam, which is not used internally, is entirely exported to a neighbouring district heating facility.

The sewage sludge incineration plant at Łódź (PL07) uses all the heat recovered from the flue-gases for heating the fluidising air and to produce the steam used to dry the sludge before incineration (no energy export).

The clinical waste incineration plant ZAVIN C.V., Dordrecht (NL04) provides steam to the nearby MSW plant HVC Dordrecht (NL03).

[74, TWG 2004], [81, TWG 2016]

Reference literature

[29, Energy subgroup, 2002], [28, FEAD et al. 2002], [30, UBA, 2002], [5, RVF 2002], [64, TWG 2003]

4.4.2 Reduction of flue-gas volume

Description

Reduction of the flue-gas flow.

Technical description

[28, FEAD et al. 2002]

Flue-gas losses correspond to the heat leaving the plant (usually considered at the boiler level) with the flue-gas. The actual loss depends on the flue-gas flow and on its temperature (enthalpy).

One of the possibilities for reducing these losses is the reduction of the flue-gas flow; to achieve this several options are possible:

- reduction of excess air, e.g. improve primary and/or secondary air distribution;
- flue-gas recirculation, i.e. replace part of the secondary air with flue-gas.

Achieved environmental benefits

Reduction of the energy used by the flue-gas cleaning system.

Environmental performance and operational data

For a municipal waste incineration plant, the energy lost via the flue-gases is typically in the range of 13–16 % of the energy input from the waste, but may be reduced to 5–8 % if the flue-gases are cooled down to the saturation point, and an additional amount of energy of up to 20 % of the waste energy input may be recovered by using low-temperature economisers and/or flue-gas condensers. Fluidised bed boilers have flue-gas losses of 8–9 %.

Cross-media effects

Reducing the gas flow by reducing the excess air and flue-gas recirculation can increase corrosion risks. If levels are reduced too far, this may jeopardise the gas burnout and leave products of incomplete combustion in the flue-gas.

Technical considerations relevant to applicability

The technique is generally applicable. The extent to which the flue-gas flow can be reduced is limited by the need to achieve complete waste burnout and, for instance when using flue-gas recirculation, by the risk of corrosion.

Economics

No information provided.

Driving force for implementation

Reduction of the overall process energy consumption and increase of energy exploitation.

[74, TWG 2004]

Example plants

Many plants in Europe.

Reference literature

[28, FEAD et al. 2002], [64, TWG 2003]

4.4.3 Reduction of overall process energy consumption**Description**

- Use of an integrated approach to target overall installation energy optimisation rather than optimising each separate process unit [74, TWG 2004].
- Placement of high-temperature equipment upstream of lower temperature or high-temperature drop equipment.
- Use of heat exchangers to reduce energy inputs.
- Use of energy generated by the WI plant that would otherwise not be used or supplied, to replace the import of external energy sources.
- Use of frequency-controlled rotating equipment.
- Use of regenerative braking systems.

Technical description

The incineration process itself requires energy for the operation of the plant. This energy can be recovered from the waste. The amount of energy required depends upon the type of waste being burned and the design of the plant.

The reduction of the installation's energy requirements needs to be balanced against the need to ensure effective incineration, to treat the waste and control emissions (particularly to air).

Common sources of significant process energy consumption are:

- waste pre-treatment (shredders, etc.);
- waste transfer/loading equipment (e.g. pumps/cranes and grabs/screw feeders);
- fuels for combustion support and start-up/shutdown (most common for low-CV wastes);
- induced and forced draught fan to overcome pressure drops and for combustion air;
- air-cooled condensers;
- flue-gas heating after wet flue-gas treatments (which cool flue-gases more than semi-wet and dry systems);
- flue-gas reheating before specific air pollution control devices (e.g. bag filters, SCR systems);
- flue-gas reheating before final discharge to reduce plume visibility;
- electricity demand from other devices.

In many cases, particularly where a step change in FGC technology is made, the lower the emission requirements, the more energy is consumed by the FGC system. It is therefore important that the cross-media impact of increased energy consumption is considered when seeking to reduce emission levels.

The following techniques reduce process demand:

- The use of an integrated approach to target overall installation energy optimisation rather than optimising each separate process unit [74, TWG 2004].
- The placement of high-temperature equipment upstream of lower temperature or high-temperature drop equipment.
- The use of heat exchangers to reduce energy inputs, e.g. for SCR systems.

- The use of energy generated by the WI plant that would otherwise not be used or supplied, to replace the import of energy from outside.
- The use of frequency-controlled rotating equipment for those equipment parts that operate at variable speeds, such as fans and pumps, where they are effectively often operated at reduced load. This will reduce their average energy consumption substantially, because pressure variations will be realised by varying speeds and not by valves.
- The use of a regenerative braking system on the waste feed crane.

The regenerative braking system feeds the energy generated during lowering and decelerating back to the supply network. This energy can also be used to power the other motions of the crane. Regenerative network braking eliminates the need for braking resistors [92, Denmark, 2015].

Achieved environmental benefits

Reducing the process demand reduces the need for external energy generation and/or allows the export of greater quantities of energy. The additional energy recovered may be supplied for use.

Environmental performance and operational data

[28, FEAD et al. 2002]

For a municipal incineration plant, the electricity consumption is typically between 60 kWh/t and 190 kWh/t of waste, depending on its LHV.

An average electricity self-consumption value of 75 kWh/t of waste is reported for a MSWI incinerating waste with a LHV of 9 200 kJ/kg, generating electrical power only (not heat), using a semi-wet FGC system and SNCR de-NO_x, and with no depluming device. In a MSWI such as this one, without pre-treatment, flue-gas reheating, or plume visibility reduction reheating, the main electrical consumption levels are roughly:

- induced draught fan: 30 %;
- forced draught fan: 20 %;
- feed pumps and other water pumps: 20 %;
- air-cooled condenser: 10 %;
- others: 20 %.

[74, TWG 2004]

Larger throughput plants may achieve some economies of scale, which result in lower energy consumption per unit of waste treated.

A regenerative network braking system can be used for waste handling and for the handling of residues. This type of system reduces the energy consumption by up to 30 %, and it eliminates the need for maintenance of the resistors. It stabilises the electricity supply to the crane against network disturbances and filters harmonic distortions from the crane to the supply network. It enables higher hoist, trolley traverse and bridge travel speeds, when the supply voltage is less than 500 V. For example, if the supply voltage is 380 V, this technique increases crane speeds by 30 % [92, Denmark, 2015].

Cross-media effects

Reducing energy consumption by FGC equipment design and operation can result in increased emissions to air.

Technical considerations relevant to applicability

Much of the additional energy consumed arises from the application of additional flue-gas treatment techniques that themselves consume energy. Reducing process energy consumption by eliminating these components is not appropriate if it is not counterbalanced by the use of other techniques that ensure the same or a better environmental performance.

Options for optimisation are greatest at new installations. There, it will be possible to examine and select from a variety of overall designs in order to achieve a solution that balances emission reduction against energy consumption.

At existing installations, options may be more limited, owing to the expense (and additional technical risk) associated with a complete redesign. Plants that have been retrofitted to achieve a better environmental performance generally have to fit tail-end gas cleaning equipment and will therefore have higher energy consumption figures.

Economics

Operational cost savings may be made by reducing the external process energy demand. Where the energy saved can be exported, this can result in additional income.

The capital costs of a significant redesign at existing plants may, in some cases, be high in relation to the benefits that can be achieved.

The cost for the installation of a regenerative network braking system depends on the crane size [92, Denmark, 2015].

Driving force for implementation

The driving force is the additional income from energy sales or reductions in operating costs due to the reduced energy use.

Example plants

No information provided.

Reference literature

[28, FEAD et al. 2002], [31, Energy subgroup 2003], [64, TWG 2003], [92, Denmark, 2015].

4.4.4 Selection of turbine

Description

Techniques to consider are:

- back-pressure turbines;
- condensing turbines;
- extraction condensing turbines;
- double stage condensing turbines.

Technical description

Back-pressure turbines are used when a significant and possibly constant amount of heat can be supplied to customers. The back-pressure level is dependent on the required temperature level of the supplied heat. The exhaust pressure of a back-pressure turbine is above atmospheric (e.g. 4 bar absolute) [74, TWG 2004]

Condensing turbines are used when there are few or no possibilities to supply heat to customers or the steam to be supplied is of too high pressure (for a back-pressure turbine) and the recovered energy is to be converted into electricity. The efficiency of the electricity production is influenced by the cooling system (see also Section 4.4.6). The exhaust pressure of a condensation turbine is under vacuum (e.g. 0.2 bar absolute depending on turbine load and ambient temperature). [74, TWG 2004]

Extraction condensing turbines are condensing turbines with a significant extraction of steam at intermediate pressure for a particular purpose. There are nearly always some extraction(s) for process use from a condensing turbine. Extraction condensing turbines are used when a significant and varying amount of heat or steam can be supplied to customers. The required amount of (low-pressure) steam is extracted from the turbine and the remaining steam is condensed.

Double stage condensing turbines heat up the steam between the two stages by using some of the input steam for superheating the steam in the second stage to reach higher energy production at low condensation temperatures, without damaging the turbine. [74, TWG 2004]

Achieved environmental benefits

The type chosen has an influence on electricity production and energy output.

Steam tapping results in optimised energy use. Savings in fossil fuels lower pollutant and greenhouse gas emissions by reduced use of additional power from external generation stations.

Environmental performance and operational data

Turbines in MSWI plants are usually not very big, typically 10 MW_e (range from 1 MW_e to 74 MW_e). The number of bleeds is usually limited to three or four (which is different to power plants where a turbine can have many more bleeds).

The low-pressure section of the turbine needs a minimum steam flow for cooling the blades, avoiding vibrations and preventing condensation.

If the remaining steam flow is too small in some operating conditions, instead of one turbo-generator with a high-pressure section and a low-pressure section, it is also possible to have two turbines (one high-pressure, one low-pressure). The choice is made based on the local conditions and the optimum choice may vary over time. [74, TWG 2004]

In order to improve the electrical generation output with condensation turbines, the steam required by the incineration process (e.g. for the de-aerator, air heater, soot blowers) is normally taken from the turbine after its expansion in the high-pressure part of the turbine. This is made by bleed(s) (also called 'extraction' or 'tapping'). These bleed(s) are said to be 'uncontrolled' because the pressure depends on the turbine load (the pressure can be divided by two at a bleed when the steam flow is reduced by 50 %). The bleed(s) are located in such a manner that the pressure(s) are high enough for the process requirement whatever the load of the turbine.

Cross-media effects

Low condensation temperatures at the end of the turbine may cause blade failure induced by corrosion as well as water hammering wear due to the high moisture content in the steam, which therefore is generally limited to less than around 10 %. [74, TWG 2004]

Technical considerations relevant to applicability

The turbine selection must be made at the same time as the rest of the steam cycle characteristics and depends more on available infrastructures and/or on the energy market than the incineration process. [64, TWG 2003]

Economics

It is reported that double stage condensing turbines require the installation of additional connections in the steam system that, in the case of the relatively small turbines that are typical of WI plants, are relatively expensive compared with the resulting increase in electrical output.

Driving force for implementation

No information provided.

Example plants

1. DE54

By steam tapping from a condensation turbine, various uses are found for the energy and the overall energy use can be optimised. The steam is carried to the turbine at a temperature of 400 °C and at a pressure of 40 bar. Tapping steam at approximately 300 °C and 16 bar for local and remote steam use and at approximately 200 °C and 4.8 bar for purely local use results in optimal energy exploitation.

The steam is used locally for air and water preheating for local systems and buildings and also for flue-gas cleaning. The remote steam is primarily used to support production processes, but also as a remote source for heating. [64, TWG 2003]

2. Rennes plant (FR) – Retrofit

Two lines each of 5 t/h of waste producing steam at 26 bar absolute and 228 °C (saturated) for DH. In 1995, a third line of 8 t/h of waste was added producing steam at the same pressure and 380 °C (150 °C of superheat).

A TG set of 9.5 MVA receives the mixed steam from the three lines with an intermediate superheat. However, the TG set can run with any of the three lines shut down. This means that it can run with the superheat of 150 °C when the two lines of 5 t/h are stopped but also with saturated steam when the 8 t/h line is offline. The turbine uses only saturated steam.

3. Three plants in Paris (FR)

These plants incinerate a total of 1 800 000 t/yr and supply 4 000 000 t/yr of steam (2 900 000 MWh_{th}/yr) to the Paris District Heating network, which corresponds to 45 % of the demand. They also generate 290 000 MWh/yr of electricity, of which 160 000 MWh/yr are supplied to the national grid.

Steam is delivered at a pressure adjusted by valve between 12 bar and 21 bar according to the DH requirements and is delivered directly to the DH network without heat exchangers. A varying part of the steam comes back as condensate. The demineralisation plants are able to produce two thirds of the steam flow rate.

The large size of the DH demand in comparison to the steam generated and the fact that the three plants supply the same DH network, belong to the same owner and are operated by the same company lead to these specific choices for the equipment.

[74, TWG 2004]

Reference literature

[64, TWG 2003]

4.4.5 Increased steam parameters and application of special materials to decrease corrosion in boilers

Description

Techniques to consider are:

- cladding;
- composite boiler tubes;
- ceramic refractory material.

Technical description

Higher steam parameters increase the turbine efficiency and result in higher electricity production per tonne of waste burned. However, because of the corrosive nature of the gases generated by the waste when it is burned, incinerators cannot use the same temperatures and pressures as some primary power generators, e.g. 100–300 bar and 620 °C. For example, a normal maximum temperature is 540 °C in coal power plants.

There is a distinction between:

- the steam pressure which gives the temperature (saturation pressure) in the water walls (which can be protected by cladding) and in the heat exchange bundles; and
- the steam temperature (superheated steam) which gives the temperature in the superheaters.

[64, TWG 2003]

In general, unless special measures are taken to avoid the effects of corrosion (which result in reduced installation availability and increased costs), MSWIs are generally limited to 40–45 bar and 380–400 °C. Above these values there is a trade-off between:

- costs of special measures, e.g. special materials to reduce corrosion;
- costs of lost availability where increased maintenance is required;
- value of any additional electricity produced.

To reduce the effects of corrosion, nickel/chromium (main components) alloy cladding or other special materials can be used for protecting exposed heat-exchange surfaces from the flue-gases. The cladding usually starts after the refractory and covers the first pass and the beginning of the second pass of the boiler, but may also be extended further down to the third pass and even to the final superheater tubes in the fourth pass depending on highly plant-specific protection needs. The refractory wall can also be air-cooled (slight overpressure) to reduce corrosion of the tubes behind the refractory. Ceramic tiles are also used to protect boiler tubes.

High-temperature corrosion of membrane walls and superheaters can be reduced by lowering the flue-gas temperature to under 650 °C before the superheaters and/or protecting heat-exchange surfaces with ceramic tiles or special alloys.

The main advantage of special alloys over a ceramic cover on the furnace walls is the better transfer of heat to the boiler, resulting in a lower temperature of the flue-gases before the first convection bundles.

An alternative to cladding is to install composite boiler tubes. Composite tubes consist of two tubes, inner and outer, metallurgically bonded together. They come in different alloy combinations. Installation of composite boiler tubes in waste incineration boilers has taken place since the 1970s. [64, TWG 2003]

Achieved environmental benefits

- The greater plant availability means that the higher emissions associated with start-up and shutdown are reduced.
- The high heat capacity of the refractory-lined furnace helps to reduce temperature fluctuations that may arise with wastes of variable LHV, thus promoting more stable incineration and reducing emissions from the combustion stage.
- A higher electrical output per tonne of waste burned can be achieved by the increase of steam pressure and/or temperature. This higher efficiency reduces external (e.g. in power plants) use of fossil fuel (resource saving) and the related CO₂ emissions (GHG).[74, TWG 2004]

Environmental performance and operational data

Higher steam parameters involve an increased technological risk and require high skill levels for assessment and maintenance.

Cross-media effects

Increased steam parameters without the application of special anti-corrosion measures increase the risk of corrosion and the associated maintenance costs and availability loss.

Technical considerations relevant to applicability

The use of increased steam parameters is applicable to all incinerators recovering electricity only, or where the heat proportion of CHP is low, to increase electricity outputs.

The technique has limited applicability to processes that have reliable options for the supply of steam or heat, since in such cases there is no need to increase the electrical output and bear the associated additional technical risk and costs.

The use of cladding and other special materials is applied to reduce corrosion when using increased steam parameters and/or highly corrosive waste content.

Existing plants that have experienced rising LHV in the waste supplied may benefit from the use of special materials and cladding because it can reduce the maintenance costs and allow improved electrical outputs.

Economics

The cost of cladding can be discounted against reduced maintenance costs and income from electricity sales and improved plant availability.

The cost of cladding has been reported to be approximately EUR 3000/m².

The range of increase in income depends on the energy price obtained.

Driving force for implementation

Higher electricity prices will encourage adoption of this technique, as it will allow faster payback of the investments required.

Example plants

High steam parameters:

- Odense (DK): 50 bar, 520 °C, with cladding.
- AVI Amsterdam, AVR Botlek, AVR AVIRA and AVI Wijster (all NL).
- AVE-RVL Lenzing (AT): circulating fluidised bed incinerator receiving various waste fractions including approximately 60 % plastics produces steam at 78 bar and 500 °C.
- Riikinvoima (FI): circulating fluidised bed incinerator receiving mechanically pretreated MSW produces steam at 80 bar and 500 °C.
- Ivry (FR): 75 bar, 475 °C.
- Mataró (ES): 60 bar, 380 °C.
- Lasse Sivert Est Anjou (FR): 60 bar, 400 °C.

Retrofit improvement:

- Rennes (FR): 26 bar, 228 °C (saturation state); a third line was added with a boiler rated at 26 bar, 380 °C; the combined steam from both lines is sent to the TG.

Application of special materials:

- Retrofit improvement: Toulon, Thiverval (FR), Mataró (ES), Stoke on Trent (UK).
- New plant: Lasse Est Anjou (FR).

[74, TWG 2004]

Reference literature

[32, Denmark, 2003], [28, FEAD et al. 2002], [2, InfoMil 2002], [3, Austria 2002], [64, TWG 2003]

4.4.6 Reduction of condenser pressure (i.e. improve vacuum)

Description

Techniques to consider are:

- air cooling;
- evaporation water cooling;
- water cooling by convection.

Technical description

After leaving the low-pressure section of the steam turbine, the steam is condensed in condensers and the heat is then passed into a cooling fluid. The condensed water from steam is recirculated and used as boiler feed water. [74, TWG 2004]

The colder the cold source the higher the enthalpy drop and, therefore, the higher the electrical energy generation. For reasons of climate conditions, it is easier to achieve this low pressure in cooler climates. This is one reason why plants in northern countries can achieve better efficiency than in southern countries [64, TWG 2003]. In any event, the final stages of the turbine have to be designed for the corresponding (low) vacuum conditions to avoid wear and tear due to water hammering. The maximum moisture content of the steam is for this reason generally limited to around 10 %.

The lowest temperatures are obtained by condensing the steam, using either air or water as cooling fluid. These temperatures correspond to pressures below the atmospheric pressure (i.e. vacuum).

Where a large DH network uses the full load production of the MSWI all year long, as occurs in Sweden or Denmark, the cold source is the cold water returned by the DH (see also Section 3.2.3.2 of the Reference Document on Best Available Techniques for Large Combustion Plants) which can sometimes be very low (e.g. 40 °C or 60 °C, see Table 4.9 in Section 4.4.11).

As soon as the steam crosses the saturation line of the 'Mollier' diagram, it starts to be wet and the percentage of moisture increases with the expansion of the steam in the turbine. In order to avoid damage to the end stages of the turbine (erosion by water drops), the amount of moisture must be limited (often to around 10 %).

[74, TWG 2004]

Achieved environmental benefits

Increased electrical energy generation is possible by improving the vacuum.

Environmental performance and operational data

The gains in electrical output are greater with the reduction of condenser pressure and the techniques are therefore of greater benefit for condensing turbines. [64, TWG 2003]

Condenser pressure/condenser types

With an ACC (air-cooled condenser) and air at 10 °C, typically a pressure in the condenser of 100 mbar absolute to 85 mbar absolute can be obtained, depending on the condenser surface. When the ambient air temperature is 20 °C, the pressure in the same ACC will be respectively 200 mbar absolute to 120 mbar absolute. The design is a compromise between a reasonable heat-exchange surface and low condensation pressure. [74, TWG 2004]

With a **hydro-condenser** (once-through cooling condenser, open loop) using river water at 10 °C, the pressure in the condenser will be around 40–80 mbar absolute, because the heat exchange is easier with water.

With an **atmospheric cooling tower**⁴, the temperature of water is bound to the temperature of the air and to its hygrometry (temperature of the humid bulb). If the wet bulb temperature is 10 °C, the condenser pressure will be around 60 mbar absolute. The steam plume above the tower can be reduced (but not avoided) by the tower design and there will be a slight increase in the condenser pressure. This type of cooler may involve risk of legionella, due to water evaporation and direct contact. It is mainly applied for small cooling requirements (such as turbine auxiliaries). [74, TWG 2004]

Theoretically, electrical energy generation increases from 24.1 % to 25.8 % (+ 7 %) if the vacuum improves from 100 mbar to 40 mbar. [64, TWG 2003]

Cross-media effects

In an open loop, i.e. a once-through cooling hydro-condenser, assuming a water temperature increase of 10 °C, the water flow needed will be around 180 m³/MWh generated.

In a closed loop with a cooling tower, the water consumption (evaporated water) is approximately 2.5 m³/MWh generated or 3 m³/MWh generated.

Both open- and closed-loop systems may require the addition of chemicals, or other techniques, to reduce fouling in the heat-exchange system and possibly process water treatment. The impacts of discharge are much larger for open systems.

Low condenser pressure increases the humidity in the steam which can increase wear in the turbine [74, TWG 2004]

Air condensers generate noise emissions. Detailed design (e.g. shielding, frequency converter noise level) is therefore important.

Cleaning of the surface of condensers is very important for their efficiency and should be carried out at low temperatures. [74, TWG 2004]

Technical considerations relevant to applicability

Where electrical generation is of lower priority (e.g. where heat supply is possible), the turbine outlet pressure can be above atmospheric. In this case, the turbine is said to be operating with back-pressure and the (remaining) steam is condensed in the condenser itself.

Especially in arid areas, air-cooled condensers are often the only possible type applicable. [74, TWG 2004]

Open-loop hydro-condensers are only suited to locations where there is an abundant water supply that can tolerate the heating effect of the subsequent discharge.

Economics

The use of higher pressure reduction techniques will be most economical where electrical energy has a higher price.

For ACCs, higher pressure drops require equipment with a larger surface area and also better-performing fan motors, which increases costs.

Driving force for implementation

Electricity prices are a key driver.

4) Cooling tower or refrigeration tower. The steam condenser cooling fluid is water. This water is in a closed loop, and is cooled itself by contact with ambient air in a cooling tower. In this tower, part of the water is evaporated. This produces a water vapour plume above the tower.

Another driving force is easier synchronisation of the TG set when the ambient temperature is high. [74, TWG 2004]

Example plants

Most European plants have an ACC installed.

The Issy and Ivry plants, near Paris, and Bellegarde (FR), as well as the Southampton plant (UK) have open-loop hydro-condensers.

The Strasbourg and Rouen plants (FR) have closed-loop hydro-condensers with cooling towers.

Reference literature

[28, FEAD et al. 2002] [64, TWG 2003]

4.4.7 Optimisation of boiler design

Description

Optimisation of boiler design in order to:

- keep the flue-gas temperature as low as possible at the boiler exit;
- avoid fouling;
- guarantee low and homogeneous gas velocities across the whole boiler;
- achieve a good heat exchange.

Technical description

The recovered heat is the energy that is transferred from the flue-gases to the steam (or hot water). The remaining energy of the flue-gas at the boiler exit is most commonly lost (unless heat-exchange systems are used further downstream). So, in order to maximise energy recovery, it is usually favourable for the temperature of the flue-gases at the exit of the boiler to be reduced.

Boiler fouling has two effects on energy recovery. The first one is that it decreases the heat-exchange coefficients and, therefore, leads to a reduction of the heat recovery. The second and most important one is that it leads to the blocking up of the heat-exchange bundles and, therefore, to the shutdown of the plant. Another unwanted effect of boiler fouling is that it increases the risk of corrosion under the deposited layer. In general, the boiler is designed to be manually cleaned at most once a year to limit boiler fouling (see Section 4.4.14).

A good boiler must have a sufficient heat-exchange surface but also well-designed geometry in order to limit fouling. This can be achieved either in vertical, horizontal or combined vertical-horizontal boiler concepts (see Section 2.4.4.2). [74, TWG 2004] Examples of good design practices are reported as follows:

- Gas velocities must be low (to avoid erosion) and homogeneous (to avoid high-velocity areas and to avoid stagnation, which can induce fouling) over the whole diameter (space) of the boiler.
- To maintain low gas velocities, the passes must have a wide cross-section and their geometry must be aerodynamic.
- The first pass(es) of the boiler should not contain heat exchangers and should have sufficient dimensions (especially height) in order to allow flue-gas temperatures below 650–700 °C. However, they can be cooled by water walls (working by convection). (These tube walls, in fact, envelop the whole boiler except the economiser. In steam boilers, they are generally a part of the vaporiser.) Radiating heat exchangers may also be placed in the open passes at higher temperatures.

- The first tube bundles must not be installed at locations where the fly ashes are still sticky, i.e. where temperatures are too high.
- The gaps between the tubes of the bundles must be wide enough to avoid 'build-up' in between them (by fouling).
- Water-steam circulation in the membrane wall and convective exchangers should be optimal in order to prevent hot spots, inefficient flue-gas cooling, etc.
- Horizontal boilers should be designed in order to avoid a flue-gas preferential path, leading to temperature stratification and ineffective heat exchange.
- Suitable devices for cleaning the boiler in situ should be provided.
- Optimisation of the convective exchanger arrangement (counter-flow, co-current flow, etc.) in order to optimise the surface according to the tube wall temperature and prevent corrosion.

[28, FEAD et al. 2002], [74, TWG 2004]

Achieved environmental benefits

Greater plant availability and better heat exchange allow increased overall energy recovery possibilities.

Design of the boiler to reduce fouling also reduces the retention of dust within temperature zones where there may be increased risk of dioxin formation.

Environmental performance and operational data

No information provided.

Cross-media effects

None reported.

Technical considerations relevant to applicability

This technique is applicable at the design stage to all incineration plants with energy recovery boilers, particularly those looking to improve the operating life and efficiency. [74, TWG 2004]

Economics

Operational savings through reduced maintenance and increased energy sales can lead to very short payback periods, and can then justify the adoption of these techniques at new installations.

Existing plants that are going to replace boilers or where lower boiler efficiencies are seen (generally less than 75 % heat transfer efficiency for municipal plants) may also take these factors into account in the design of the new system.

Driving force for implementation

Decreased maintenance, increased energy recovery and possible income from energy sales are all driving forces for implementation.

Example plants

Widely applied throughout Europe.

Reference literature

[28, FEAD et al. 2002], [2, InfoMil 2002], [64, TWG 2003]

4.4.8 Use of an integral furnace-boiler

Description

The use of an integral furnace-boiler.

Technical description

Transporting very hot gases in ducts lined with refractory can be complex. It can result in sticky and sometimes molten deposits. In order to avoid this, the gas temperature is sometimes reduced by increasing the excess air volume, which can result in a loss of efficiency.

In an integral furnace-boiler, the boiler directly covers the furnace without intermediate piping. Therefore, the boiler tubes can cool the furnace sides. The tubes are protected by refractory and cool it (cross-benefit). A suitable design of the tubes and refractory allows fine control of the cooling of the furnace. Effective cooling of the furnace is essential to avoid clogging in the furnace, especially with a higher LHV.

Achieved environmental benefits

This technique improves heat recovery by reducing the heat losses by radiation at the furnace outlet (to complement the effect of the external lagging).

Environmental performance and operational data

This technique avoids clogging in the furnace and, therefore, the need for shutdowns for manual cleaning.

Cross-media effects

None reported.

Technical considerations relevant to applicability

Generally applicable to grate furnaces. Not applicable to rotary and oscillating kilns.

Economics

Integral furnace-boilers are usually less expensive than a separate boiler for plants above very small-capacity furnaces (i.e. 1 t/h or 2 t/h).

Driving force for implementation

This technique is normal practice for designers today.

Example plants

Most plants have an integral boiler-furnace (except rotary and oscillating kilns).

Reference literature

[28, FEAD et al. 2002] [64, TWG 2003]

4.4.9 Use of a platen-type superheater

Description

The use of a platen-type superheater.

Technical description

Platen-type superheaters are flat panels of folded tubes installed in parallel with wide gaps in between and parallel to the gas flow. The inlet is protected by shells made of stainless steel, held in place with special cement.

The heat exchange is carried out by radiation instead of convection; because of this, these superheaters can be installed at hotter locations than the tube bundles (in flue-gases up to 800 °C when incinerating municipal waste), with limited fouling and reduced erosion and corrosion.

On these platen superheaters, the fouling deposits can stabilise when their thickness is around 2 cm, without causing blocking. Manual cleaning and associated shutdowns are therefore greatly reduced.

Due to radiation exchange, the steam temperature can remain constant over a period of one year of operation. Erosion and corrosion are significantly delayed.

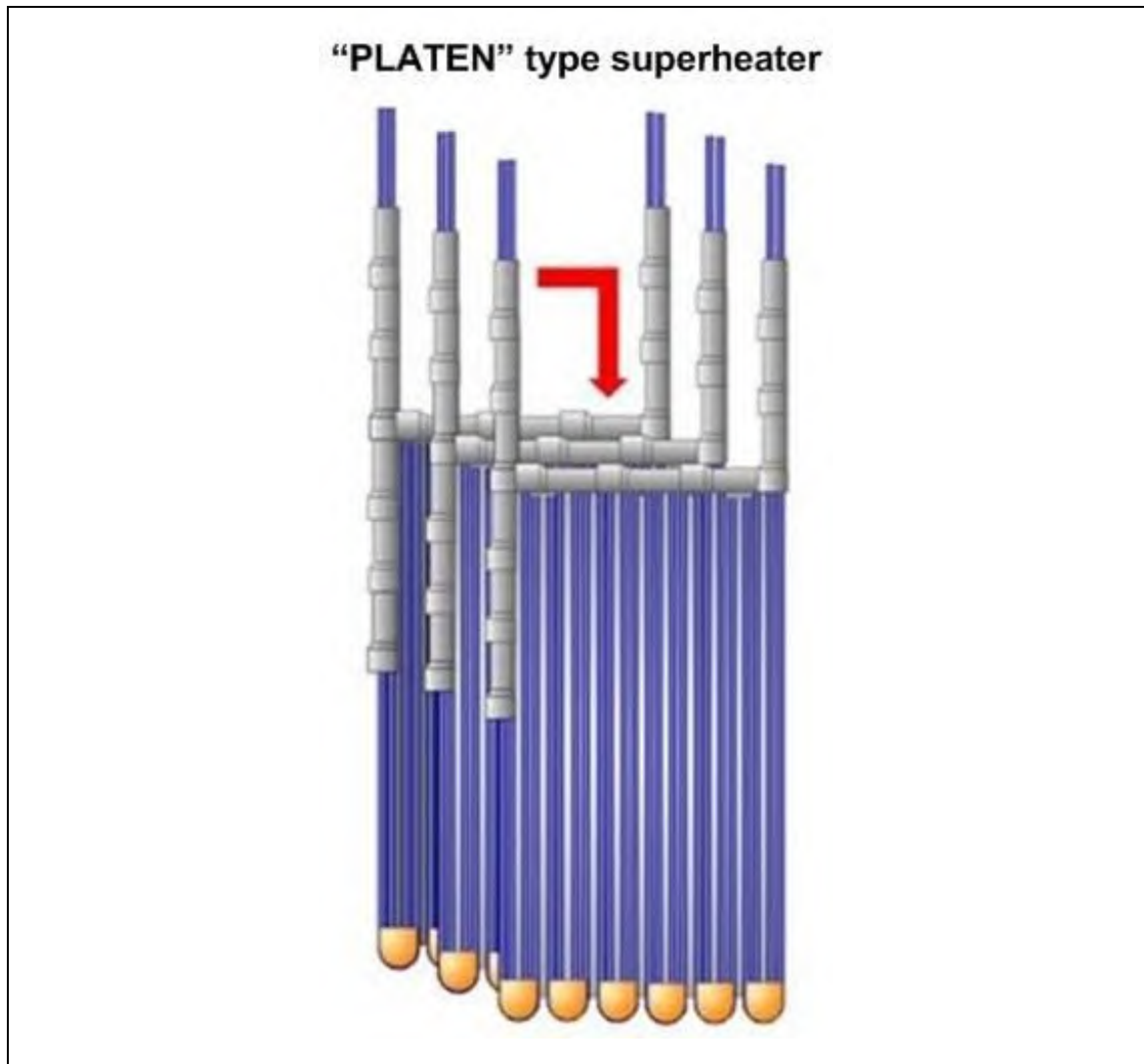

Figure 4.4: Schematic diagram of a platen-type superheater

Achieved environmental benefits

This technique increases energy recovery. Platen-type superheaters allow a high superheated steam temperature with good availability and stability.

Environmental performance and operational data

No information provided.

Cross-media effects

None reported.

Technical considerations relevant to applicability

It can be installed in boilers with two or three open passes.

Economics

This technique is less expensive than bundles for last-stage superheaters (the hotter ones) when installed in areas with hotter flue-gas temperatures (second or third pass).

Driving force for implementation

The driving force is the longer operation period with a high superheated steam temperature.

Example plants

- Toulon 3, Thiverval 3, Lons le Saunier, Cergy Saint-Ouen l'Aumône, Rennes 3, Monthyon, Chaumont, Nice 4, Belfort, Villefranche sur Saône, Toulouse-Mirail 1 and 2, Lasse (Saumur) (FR).
- Thumaide (BE).
- London SELCHP, Stoke-on-Trent, Dudley, Wolverhampton, Chineham, Marchwood (UK).
- Mataró (ES).
- Maia, Loures and Santa Cruz (Madeira) (PT).
- Piacenza (IT).
- Moscow (Russia).

Reference literature

[28, FEAD et al. 2002] [64, TWG 2003]

4.4.10 Low-temperature flue-gas heat exchangers

Description

Techniques to consider are:

- the use of heat exchangers made of corrosion-resistant materials;
- design of the cycle to avoid conditions leading to corrosion.

Technical description

[2, InfoMil 2002]

Additional heat-exchange capacity in the boiler can improve possibilities for use of that heat elsewhere and, hence, can contribute to improved energy efficiency. How much the flue-gas temperature at the end of the boiler can be reduced depends on:

- the fact that at temperature levels below 180 °C there is an increased risk of corrosion of the last bundles of the economiser and of the piping upstream of acid gas scrubbing (as the dew point of the various acids is progressively approached);
- whether the heat in the flue-gases is required for the operation of subsequent flue-gas cleaning equipment;
- whether there is a beneficial use for the additional heat recovered at low temperature.

With MSW flue-gases (and other flue-gases containing these substances), the corrosion risks arise not only from HCl but from the SO_x, which are often the first to attack steel. The dew point depends on the concentrations of the acid gases and on the water content in the flue-gases. In the clean gas it can be around 100 °C, in the raw gas 130 °C or more.

The key temperature to consider in terms of corrosion risk is not the temperature of the flue-gas but the (lower) surface temperature of the (cooled) metal tubes of the exchanger (which is necessarily colder than the flue-gas). [74, TWG 2004]

Heat exchangers made of special materials (e.g. enamel) reduce low temperature corrosion problems. An example is found at AVI Amsterdam, where a heat exchanger is located after the spray absorber system and the related ESP. An additional advantage of this is the related reduction of scrubbing temperature, which improves the efficiency of the scrubbing system.

It is possible to design the cycle in such a manner as to avoid the corrosion conditions. In Sweden, for example, it is quite common to install a separate waste heat boiler after the main boiler or ESP. It is often cooled by a separate hot water circuit and by a heat exchanger connected to the district heating network. The outlet flue-gas temperature is normally about 130–140 °C and the water inlet temperature should not be under 115–120 °C to avoid corrosion. At these temperature levels, normal carbon steel tubes can be used without corrosion problems. [64, TWG 2003]

Achieved environmental benefits

The recovered heat (temperature level 120 °C for example) can be used for heating purposes and/or internally for preheating of the boiler feed water, etc.

Environmental performance and operational data

[28, FEAD et al. 2002]

Lowering the flue-gas temperature at the boiler outlet is limited by the acid dew point, which is a very important limitation in many FGC systems. In addition, the flue-gas cleaning system may require a certain working temperature or a temperature difference, as in the following examples:

- With semi-wet FGC processes, the minimum temperature at the inlet is determined by the fact that the water injection decreases the temperature of the gases. Typically, it will be 190 °C or 200 °C, and can be higher.
- A dry FGC process can generally accept 130–300 °C. With dry sodium bicarbonate, the minimum required temperature is 170 °C to obtain a fast expansion of the sodium bicarbonate's surface area and, subsequently, more efficient sodium carbonate (the so-called popcorn or diatomite effect). The reagent consumption changes with the temperature.
- Wet FGC systems do not have a theoretical minimum inlet temperature – the lower the gas temperature at the scrubber inlet, the lower the water consumption of the scrubber. It is however usual to operate at inlet temperatures no lower than 90–100 °C in order to obtain full saturation of the flue-gas.

[74, TWG 2004]

Cross-media effects

Lower flue-gas temperatures at the stack exit can result in:

- highly visible condensed plumes (less of a problem if condensing scrubbers are used as they reduce the water content of the flue-gases);
- reduced plume buoyancy and, hence, dispersion;
- corrosion in stacks (lining with fibreglass or similar required).

With flue-gas cleaning systems that require the flue-gases to be above a particular operating temperature (e.g. bag filters, SCR), any heat removed will need to be re-added later in the process. Such reheating is likely to result in additional consumption of primary fuels or external power.

Technical considerations relevant to applicability

New plants have the most significant opportunity for including (in the design) techniques to reduce losses through the flue-gases. Plants that have an outlet for the supply of relatively low temperature heat (most common in colder climates) are best placed to make use of the additional heat removed from the flue-gases. Where this heat cannot be supplied to external users or used within the plant, this low-grade heat may be better employed within the flue-gas to aid dispersion, etc.

The optimisation of the boiler outlet temperature is generally applicable, although the extent to which this temperature can be reduced is related to the temperature requirements of the downstream FGC equipment, and in any case needs to take account of the acid dew point of the flue-gas in order to avoid corrosion of the last bundles of the economiser.

Changes to the design exit temperature of the boiler must take account of the requirements of subsequent flue-gas cleaning operations. The removal of heat that must later be re-added from another source is likely to be counterproductive from an energy efficiency point of view, owing to additional losses from the heat exchange process.

Reducing the flue-gas temperature after the boiler is only applicable where:

- the heat extracted can be put to some use (supplied externally or used internally);
- subsequent flue-gas cleaning systems are not adversely affected; this is especially relevant with the use of bag filters, SCR, or other systems that require particular operating temperatures or conditions.

Space requirements may limit the implementation in existing plants.

Economics

The technique is most likely to be economically viable where the value/price paid for the additional heat recovered is high.

Driving force for implementation

Supply of additional heat recovered.

Example plants

- AVI Amsterdam (NL).
- Brescia (IT).
- Many plants in Sweden and Denmark.
- Sheffield (UK).
- Rennes, Nice, Saint-Ouen (FR).
- Monaco.

Reference literature

[2, InfoMil 2002], [64, TWG 2003]

4.4.11 Use of flue-gas condensation scrubbers

Description

The use of a flue-gas condensation scrubber.

Technical description

The technique is described in Section 2.4.4.5.

In a flue-gas condensation scrubber, the flue-gas is cooled by direct contact with circulating cooling/process water. The cooling water, via an intermediate heat exchanger, is also typically in contact with a district heating network. Provided that the temperature of the district heating return flow is low enough, the water vapour in the flue-gas will reach its dew point. At the dew point, the vapour will condense and latent heat will be transferred to the intermediate cooling circuit. District heating water is thus heated by the energy recovered from the flue-gas condensation. Heat pumps can also be used to further increase energy recovery.

The flue-gas condensation scrubber also reduces the concentration of water-soluble pollutants such as HCl and, if NaOH is dosed into the scrubbing water, also of SO₂ and HF.

Removing water from the flue-gas reduces the gas volume. If the flue-gas fan is downstream of the flue-gas condenser, the energy requirement for the fan is also reduced.

Achieved environmental benefits

The use of condensing scrubbers allows the extraction of additional energy from the flue-gases for possible use or supply.

The amount of additional energy recovered is dependent upon the return water temperature in the district heating system. Table 4.9 shows the relationship between the additional energy efficiency and the cooling medium (district heating) return temperature at the conditions typical for a Scandinavian waste incineration plant; note that the water content in the waste (and thereby in flue-gas) will have a major effect on this. The additional energy efficiency in Table 4.9 is expressed as a percentage of the energy content (as the LHV) of the waste incinerated.

Table 4.9: Relationship between the additional energy efficiency and the cooling medium (district heating) return temperature

District heating return temperature (°C)	Additional energy efficiency
40	14 %
50	7 %
60	0 %

Source: [5, RVF 2002]

The drying effect on the flue-gases reduces the plume visibility. Where energy is used to reheat the plume, the amount of energy required to achieve a given reduction in plume visibility will be lower.

Emissions of ammonia to air (e.g. from SNCR) may be reduced. The ammonia is captured in the scrubber water. By using an ammonia stripper at the water treatment plant, it is possible to regenerate ammonia for use as a NO_x reduction reagent.

The condensed water can be used to provide the majority of the scrubber feed water, therefore reducing water consumption.

Environmental performance and operational data

This technique is most applicable where:

- district heating gives a reliable low temperature return (this is essential and generally only available in colder climates);
- plume visibility is a concern;
- prices paid for the additional energy recovered justify the additional capital investment;
- additional flue-gas cleaning, in particular for acid gases, is sought.

Because the technique is applied after the flue-gas cleaning stages, in principle the technique could be applied to any waste type.

The technique is applied at/near the end of the FGC system and could, therefore, be applied to new and existing plants.

At the Högdalen, Stockholm (SE) plant, this system is used with three conventional grate-fired steam boilers and one with a circulating fluidised bed. Flue-gases from the conventional grate-fired boilers are cooled in shot-cleaned waste heat boilers to about 140 °C. Return water from district heating is used as the cooling medium.

FGC starts with a dry cleaning system for each boiler in which dry hydrated lime is injected and mixed with the flue-gas in a reactor. The acid impurities react with the hydrated lime and solid salts are formed which are removed in a fabric filter together with fly ash and the excess of hydrated lime. The fluidised bed boiler has a slightly different reactor as recirculated dust from the fabric filter is slightly humidified before it is mixed with fresh hydrated lime and injected into the flue-gases.

The second cleaning stage includes wet scrubbers, which saturate the flue-gas and remove the rest of the acid gases, particularly hydrogen chloride (HCl) and sulphur dioxide (SO₂). The saturated gas leaving the wet scrubbers has a temperature of about 60 °C. It is sucked to a tube condenser, which is cooled by return water from the district heating network at a temperature of 40–50 °C. One wet system is used for all three grate boilers, although the CFB boiler has its own.

If the return water temperature is 40 °C (the normal case for this plant but very low in comparison with the majority of European climates), 14 % additional energy is recovered in the condenser. On the other hand, if the return water temperature is 50 °C, only about 7 % additional energy is recovered. For extreme cases, when the return water temperature is as high as 60 °C, no extra heat is recovered.

In the Högdalen (Stockholm) case, the flue-gas is reheated before the induced draught fan and stack, requiring the consumption of some low-pressure steam. It is also possible to operate without this reheat but with a wet fan and stack.

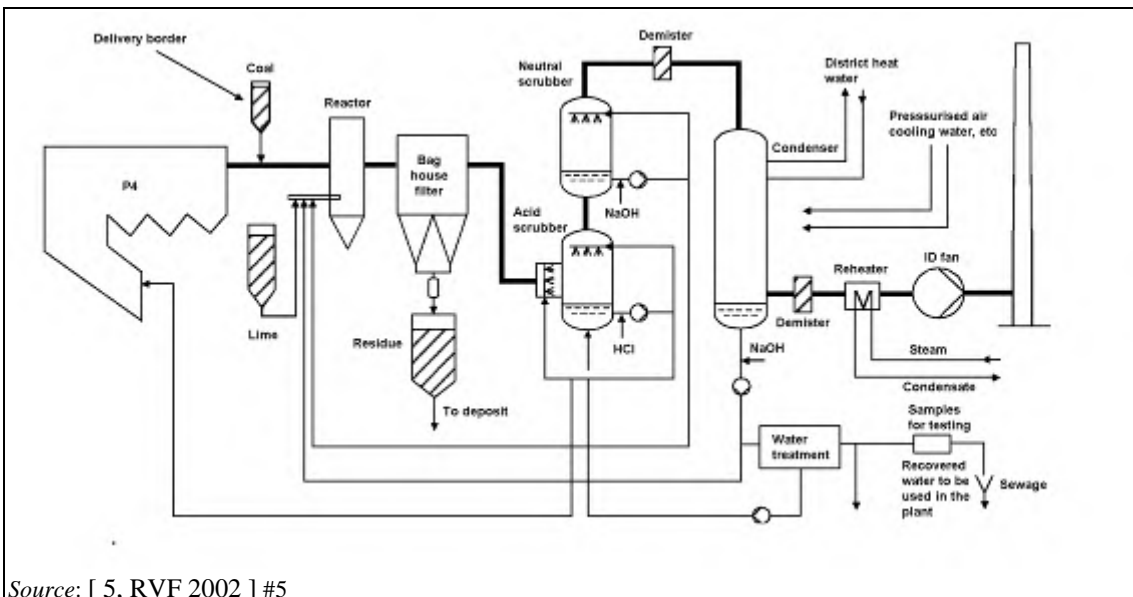

Source: [5, RVF 2002] #5

Figure 4.5: Pollution control and additional heat recovery by condensation of flue-gas water vapour at the Högdalen waste-fired CHP plant

Cross-media effects

The low temperature of the flue-gases can result in condensation and, hence, corrosion in the chimney unless lined or double-tube systems are used.

The condensed water will contain pollutants (removed from the flue-gas) that require treatment in a water treatment facility prior to discharge. Where an upstream wet scrubbing system is applied, the effluent from the condensing scrubber can be treated in the same facility.

The low temperature of the stack discharge will reduce the thermal buoyancy of the plume and, hence, reduce dispersion. This can be overcome by using a stack that is taller and/or has a reduced diameter.

Technical considerations relevant to applicability

The technique is not applicable where:

- there is no user for the additional energy recovered;
- the cooling source (DH cold water return) is less reliable (i.e. warmer climates).

Plant size: The technique is known to have been applied at municipal plants of 37 000 t/yr throughput (DK), 175 000 t/yr throughput (SE) and 400 000 t/yr throughput (SE).

Economics

The total additional investment for the condensation stage is roughly estimated as EUR 3 million for four boilers serving a MSWI CHP plant with a capacity of 400 kt/yr.

Driving force for implementation

- Additional heat sales.
- Water conservation in dry regions.

[74, TWG 2004]

Example plants

There are several examples in Sweden (see examples in Section 2.4.4.5). Possibilities are fewer in warmer climates owing to the reduced availability of cool DH water return.

Reference literature

[5, RVF 2002], [64, TWG 2003]

4.4.12 Use of heat pumps to increase heat recovery**Description**

The use of a heat pump.

Technical description

The technique is described in Section 2.4.4.6, where the three main types of heat pumps are also described.

In summary, heat pumps provide a means of uniting various relatively low temperature heat and cooling sources to upgrade the temperature of a stream. This allows, for example, the operation of condensing scrubbers (see Section 4.4.11) and the supply of the additional heat to users.

Achieved environmental benefits

This technique enables the recovery of additional energy by the use of condensing scrubbers.

An increase in the quantity of energy recovered of 23 % was reported when using absorption heat pumps in combination with condensing scrubbers. [35, Renova, 2002]

Based on the example of the Umea plant in northern Sweden (175 kt waste/yr), the following estimated energy balance is seen:

The power balance including condensation and compressor heat pump:

Thermal power input	65 MW _{th} (approximately)
Electricity output from generator	15.1 MW _e
Internal electricity consumption	5.4 MW _e
Electricity output, net	9.7 MW _e
Hot water generation incl. cond.+ heat pump	54 MW _h
Own consumption for reheat	0.5 MW _h
Hot water to district heating	<u>53.5 MW_h</u>
Total power and heat for sale	<u>63 MW</u>

Without FG condensation and heat pump, the power balance is estimated as:

Thermal power input	65 MW (approximately)
Electricity output, net	13 MW
Hot water to district heating, net	<u>39 MW</u>
Total power and heat for sale	<u>52 MW</u>

Environmental performance and operational data

See detailed information given in Section 2.4.4.6.

The technique is most applicable where:

- district heating gives a reliable low temperature return;
- district heating uses most of the available heat;
- prices paid for the additional energy recovered justify the additional capital investment;
- wet scrubbing is used;
- plume visibility is a concern.

[74, TWG 2004]

Waste types: because the technique is applied after the flue-gas cleaning stages, in principle the technique could be applied to any waste type.

Plant size: the technique is known to have been applied at municipal plants of 175 000 t/yr throughput and 400 000 t/yr throughput.

Retrofittability: the technique is applied at/near the tail end of the FGC system and could therefore be applied to new and existing processes alike.

Cross-media effects

The heat pumps themselves require energy to function.

For compressor-driven heat pumps, the ratio between output heat and compressor power (heat to power ratio) can be about five [5, RVF 2002].

Technical considerations relevant to applicability

The technique is less applicable where there is no user for the additional energy recovered.

Economics

For the example of installing heat pumps at a MSWI in Sweden [35, Renova, 2002], the investment cost was reported as EUR 4.5 million in 1988, as well as EUR 5.5 million in 2002 (12 MW capacity), to be compared with an additional income of EUR 24.5 million between 1998 and 2002.

The additional investment at the Umea plant for the condensation stage and electric motor-driven compressor heat pump and bigger water treatment plant was estimated to be EUR 4 million, giving a simple payback time from the proceeds for heat and power sales of about 2.4 years (without considering increased maintenance and consumables).

Driving force for implementation

Additional heat sales and income are the drivers.

Example plants

Several examples in Sweden – see Section 2.4.4.6.

Reference literature

[5, RVF 2002] [64, TWG 2003]

4.4.13 Special configurations of the water/steam cycle with external power plants

Description

The use of an external combustion plant to increase the steam parameters.

Technical description

[2, InfoMil 2002] Due to the corrosive nature of the flue-gases, the efficiency of electricity production of municipal waste incineration is limited by the maximum acceptable temperature of the boiler tube materials and by the related maximum steam temperature (see Section 4.4.5).

An option that avoids higher temperatures of boiler tube materials is the superheating of the steam using cleaned flue-gases, which contain much less or no chlorine. This is possible if the waste incineration plant can be combined with a combustion plant of a sufficient capacity [94 Finland, 2016].

Achieved environmental benefits

Improved energy efficiency.

Environmental performance and operational data

With these types of configurations, the incineration process does not need to adopt high steam temperatures and therefore avoids corrosion and availability difficulties. However, sometimes the pressure may be increased in order to benefit further from the integration. In such cases, the higher steam temperature in the evaporator may lead to additional maintenance costs. For instance, at 40 bar the saturation temperature is 250 °C and at 100 bar 311 °C, a difference of 61 °C. Note that corrosion increases exponentially with the external temperature of the boiler tube walls when coming into contact with flue-gases.

Example: Municipal waste incineration plant, Laanila, Oulun (Finland)

The Laanila municipal waste incineration plant in Oulun (Finland) is part of a system formed by the WI plant, one external superheater of 6 MW_{th} using lean gas coming from a nearby chemical plant to raise the steam temperature from 420 °C to 515 °C, and three other boilers combusting peat and oil. This plant system incorporates two steam turbine units with a total electrical output of 25 MW_e. The steam generated in the system is used to drive the turbines. For this purpose, the steam flow is conveyed with a pressure of 8.3 MPa and temperature of 515 °C via a common steam pipe to the turbines. From this process, 100 MW_{th} are fed into the local district heating network.

The exhaust gases from the final superheater are introduced into the boiler's furnace area for further use of their heat content.

Table 4.10 provides a theoretical comparison between the achievable efficiency before and after the installation of the external superheater.

Table 4.10: Comparison of the achievable electrical energy efficiency with the external superheater at the Laanila plant

	Unit	Without ESH	With ESH
Steam pressure	MPa	6.2 ⁽¹⁾	8.4
Seam temperature	°C	420	515
Thermal capacity DE	MW _{th}	48.0	48.0
Thermal capacity ESH	MW _{th}	0	4.7
Electrical output	MW _e	13.3	15.8
Efficiency range	%	27.2	29.3
Electrical efficiency range of the ESH	%	0.0	53.2

⁽¹⁾ The steam pressure is defined by the steam moisture in the final turbine stage; with a temperature of 420 °C, a steam pressure of 8.4 MPa cannot be achieved.
 NB: DE = direct export; ESH = external superheater.
 Source: [94 Finland, 2016].

This technique is mainly applicable where the focus of energy recovery is the production of electricity. It is less suited to plants that can supply steam or heat directly to a user.

Cross-media effects

The external superheater increases the use of fossil fuels.

Technical considerations relevant to applicability

The technique is generally applicable to new plants.

Economics

The technique is only applicable where the location allows for a synergistic operation and suitable commercial agreements are in place.

High electricity prices encourage the adoption of techniques that increase electrical efficiency. In this case, this has the impact of increasing the relative value of the steam/heat supplied by the incinerator to the adjacent power plant.

The external superheater is generally applicable to new plants. In existing plants, the retrofitting may not be economically sustainable [94 Finland, 2016].

Driving force for implementation

Integration of the energy supply with an external user increases the options for the use of energy derived from the waste.

Example plants

ES08, FI04, NL06.

Reference literature

[28, FEAD et al. 2002], [2, InfoMil 2002], [64, TWG 2003], [74, TWG 2004], [94 Finland, 2016].

4.4.14 Effective cleaning of the convection bundles

Description

Techniques to consider include techniques for on-line cleaning, for off-line cleaning, and the prevention of higher temperature (above 650 °C) gases coming into contact with convective heat-exchange bundles.

Technical description

[2, InfoMil 2002]

Clean boiler tubes and other heat-exchange surfaces result in better heat exchange. This may also reduce the risk of dioxin formation in the boiler.

Cleaning may be carried out on-line (during boiler operation) and off-line (during boiler shutdowns and maintenance periods). The dimensions of the boiler and heat exchanger design (e.g. tube spacings) influence the cleaning regime.

Techniques for on-line cleaning include the following:

- Mechanical rapping.
- Soot-blowing by steam injection.
- High- or low-pressure water spraying (mainly on the wall in the empty passes of the boiler).
- Ultrasonic/infrasonic cleaning.
- Shot cleaning or mechanical pellet scouring.

- Explosive cleaning. This technique uses the pressure waves generated by the explosion of an oxygen/ethane gas mixture or of explosives such as dynamite, and enables heat exchange values close to the plant's nominal ones to be re-established after cleaning [95, ESWET, 2015].
- High-pressure air injection (from 10 to 12 bar) with movable lances.
[74, TWG 2004]

Off-line techniques include:

- periodic manual cleaning (in general once a year in MSWI);
- chemical cleaning.
[74, TWG 2004]

In addition to these techniques, it can also be beneficial to prevent higher temperature (above 650 °C) gases (when fly ashes are more sticky and hence more likely to adhere to surfaces they come into contact with) coming into contact with convective heat-exchange bundles by:

- including empty passes with water walls only;
- using large furnace dimensions and hence lower gas velocities before the bundles.

Explosive cleaning is used in operation when the flue-gas temperature at the superheater inlet increases, and also before the scheduled shutdown for maintenance. By drastically diminishing the deposits to extract before performing the work, the shutdown duration can be reduced and thus the annual availability of the whole installation increased [95, ESWET, 2015].

Achieved environmental benefits

Improved heat-exchange increases energy recovery.

The PCDD/F reformation risk may be reduced by effective cleaning. This is because it reduces the amount of time that dusts (and other materials that can promote their formation) are present at temperatures of between 450 °C and 250 °C – where reaction rates are at their highest.

By soot-blowing with self-produced steam injection, most of the energy will be recovered by the boiler itself (80–90 %). [74, TWG 2004]

Environmental performance and operational data

Those techniques that allow continuous on-line tube cleaning (normally operated once per 8-hour shift) normally have reduced downtime for boiler maintenance cleaning operations.
[74, TWG 2004]

Usually, manual cleaning is done when fouling has induced a flue-gas temperature increase of 20 °C to 50 °C, i.e. a 1.5 % to 3 % decrease in energy efficiency.

Potential mechanical damage of the boiler structure/tubes can occur, particularly with explosive cleaning and mechanical rapping. While this depends on the initial state, explosive cleaning is generally able to remove more than 80 % of the cumulated deposits and to return the plant to operating conditions close to the nominal values [95, ESWET, 2015].

Tube erosion caused by clogging can lead to decreasing energy efficiency and eventually tubes will require replacement.

Cross-media effects

Consumption of the soot-blowing agent, e.g. high-pressure water, low-pressure water, steam (only partially).

Noise may be an issue with some of the techniques, e.g. explosive cleaning, mechanical rapping.

Technical considerations relevant to applicability

The technique is generally applicable.

Economics

No information provided.

Driving force for implementation

The driving forces are improved availability and heat recovery, and reduced corrosion, emissions and energy consumption. [74, TWG 2004]

Example plants

All waste-to-energy plants. [74, TWG 2004]

Specific cleaning systems exist in several plants in the Netherlands and Denmark, e.g. AVI ARN Beuningen (explosive cleaning with gas), AVI Amsterdam and AVI Wijster (explosive cleaning with dynamite). [74, TWG 2004]

Reference literature

[2, InfoMil 2002], [1, UBA 2001], [64, TWG 2003], [95, ESWET, 2015]

4.5 Flue-gas cleaning and air emission prevention techniques

4.5.1 Factors to consider when selecting flue-gas cleaning systems

4.5.1.1 General factors

[54, dechefdebien, 2003]

The following (non-exhaustive) list of general factors requires consideration when selecting flue-gas cleaning (FGC) systems:

- type of waste, its composition and variation;
- type of combustion process, and its size;
- flue-gas flow and temperature;
- flue-gas content, including magnitude and rate of composition fluctuations;
- target emission limit values;
- restrictions on discharge of aqueous effluents;
- plume visibility requirements;
- land and space availability;
- availability and cost of outlets for residues accumulated/recovered;
- compatibility with any existing process components (existing plants);
- availability and cost of water and other reagents;
- energy supply possibilities (e.g. supply of heat from condensing scrubbers);
- availability of subsidies for exported energy;
- tolerable disposal charge for the incoming waste (both market and political factors exist);
- reduction of emissions by primary methods;
- noise;
- arrangement of different flue-gas cleaning devices if possible with decreasing flue-gas temperatures from boiler to stack.

[74, TWG 2004]

4.5.1.2 Energy optimisation

Some flue-gas treatment techniques can add significantly to the overall energy requirements of the incineration process. It is necessary to consider the additional energy requirements imposed by applying lower ELVs. The following key observations can be made:

- Reducing dust emissions including boiler ash (and metals filtered with dust) generally requires additional filtration and increases energy consumption.
- Reducing NO_x emissions to below 100 mg/Nm³ is most often achieved using SCR – which, due to the catalyst sensitivity to fouling and acid attacks, is generally used as a low-dust system in waste incineration, situated at the clean gas end of the FGC system. It therefore usually requires some additional energy for flue-gas reheating. Very low SOX levels in the raw flue-gas may allow SCR to be used without reheating (see Section 2.5.5.2.2). The energy required for the additional flue-gas cleaning (to achieve very low emission levels) will result in a reduction of the amount of energy generated by the incinerator that is available for export, or in the equivalent consumption of externally supplied energy. Although infrequent, high-dust SCR is used in some waste incineration plants.
- The boiler exit temperature has a major influence on FGC energy requirements – if it is below the acid dew point, additional energy input will be required to heat the flue-gas.

- In general, placing the FGC components so that those requiring the highest operational temperatures precede those that operate at lower temperatures results in a lower overall FGC energy demand (but this cannot be achieved in all cases, e.g. SCR usually requires clean gas and is therefore placed after the lower temperature gas cleaning stages, as implementing high-dust SCR avoids the use of energy to reheat the flue-gas but is challenging to implement).

[64, TWG 2003] [74, TWG 2004]

4.5.1.3 Overall optimisation and the 'whole system' approach

As well as considering the energy aspects (see sections on energy above), there is a benefit to considering the FGC system as a whole unit. This is particularly relevant to the removal of pollutants because the units often interact, providing primary abatement for some pollutants, and having an additional effect on others. Depending on the position in the cleaning sequence, different cleaning efficiency values are obtained. [74, TWG 2004] Multifunctional devices are common, and include the following:

- If a bag filter (BF) is used downstream of reagent injection, in addition to its dedusting effect, it acts as a complementary reactor. The pressure drop through the fabric material distributes the flue-gas on the adhered cake which contains some deposited reagent and, due to the low velocity of the gases, the residence time is long. A BF can, therefore, contribute to the treatment of acid gases, gaseous metals such as mercury and cadmium, and POPs (persistent organic pollutants) such as PAHs, PCBs, dioxins and furans.
- In addition to acid gas treatment, wet scrubbers can help with capturing some dust and, if the pH is low enough and/or with the use of scrubber reagents, mercury.
- SCR de-NO_x has an additional destruction effect on dioxins if designed (sized) accordingly.
- Adsorption by activated carbon and lignite coke has an effect on dioxins as well as on mercury and other substances.

[64, TWG 2003], [54, dechefdebien, 2003]

4.5.1.4 Technique selection for new or existing installations

Overall optimisation and the interface between FGC system components (as well as the rest of the incineration process) is important for both new and existing installations. With existing installations, the number of options may be more severely restricted than with new installations. Information regarding inter-process compatibility may be found in the sections that deal with individual FGC techniques.

4.5.2 Techniques to reduce dust emissions

The application of a system to remove dust from the flue-gas is generally considered essential for all waste incineration plants.

This section considers the locating of a dust removal stage before other subsequent FGC stages (i.e. upstream dedusting or pre-dedusting) or after other FGC systems (i.e. downstream dedusting). Upstream dedusting is used in combination with wet processes in order to protect the scrubbers. Downstream dedusting is generally necessary for dry and semi-wet processes in order to capture at the same time as dust the salts produced by the reaction between acid gases and alkaline reagents. In some cases, double dedusting is applied, in which case the downstream deduster is sometimes called polishing deduster. [7, TWG 2017]

4.5.2.1 Pre-dedusting stage before other flue-gas treatments

Description

This section refers to a dust removal stage located after the pre-dedusting in the boiler, [74, TWG 2004] but generally before other subsequent FGC stages.

Technical description

The following pre-dedusting systems are used for waste incineration:

- cyclones and multi-cyclones (generally in combination with other FGC components for the efficient capture of the finer dust fractions);
- electrostatic precipitators (ESPs);
- bag filters (BFs).

The individual techniques are described in Section 2.5.3.

Wet ESPs are not generally applied to pre-dedusting on account of the flue-gas temperatures in the pre-dedusting area. [64, TWG 2003] In general, they are used for polishing after scrubbing. [74, TWG 2004]

Achieved environmental benefits

Benefits include the reduction of emissions to the flue-gas stream by reducing the particulate load on later FGC processes.

Separation of the fly ash from the FGC residues allows:

- reductions in the quantity of FGC residues produced;
- separate treatment of fly ashes for possible recycling uses.

Pre-dedusting reduces dust loads on subsequent FGC systems. These may then be reduced in capacity and will experience reduced clogging risks, and hence downstream units may be designed smaller and with some degree of reduced costs.

Separate collection of the flue-gas components will not be of any environmental benefit if the separated residues are then remixed afterwards. Consideration of downstream aspects is therefore required to evaluate the possibility of real benefits. [64, TWG 2003]

ESPs and cyclones alone may have problems reaching the required dust emission levels. However, they are useful as pre-dedusters and contribute to meeting the lowest emission levels when applied in combination with other techniques.

Environmental performance and operational data

[2, InfoMil 2002] Cyclone collection efficiency increases directly as a function of the dust load, flue-gas flow rate, particle size and density. As the fly ash particles are fine, the density is low and the dust load and flue-gas flow rate change, so the dust removal efficiency of cyclones is limited. Normally, dust concentration values no lower than 200–300 mg/Nm³ can be reached. Multi-cyclones, which are based on the same removal principle, can reach somewhat lower values, but values below 100–150 mg/Nm³ are very difficult to achieve.

[2, InfoMil 2002] An ESP can reach substantially lower dust concentration values than (multi-) cyclones. Depending on the design and the siting in the flue-gas treatment system (pre- or downstream dedusting), and the number of fields, dust emission concentration values of 15–25 mg/Nm³ can normally be achieved. Achieving values below 5 mg/Nm³ is possible with more fields (two or three) and an increased ESP surface (and hence increased cost and space requirements).

Bag filters are generally very efficient dust removers. Where bag filters are used, most commonly reagents are also injected (although this is not always the case) to build a pre-coat layer over the bags to protect against corrosion and help filtration (especially for deep filtration). [74, TWG 2004] The reagents used are commonly hydrated lime and activated carbon. Activated carbon reduces the dioxin and mercury loads passing on to the subsequent flue-gas cleaning stages. For wet systems, this helps to reduce the memory-effect dioxin build-up in the scrubber materials.

Care should be taken concerning the level of ash in the hopper as well as cinder (especially if bag filters are installed directly after the boiler) to prevent risk of fire.

[2, InfoMil 2002] Cyclones are a relatively simple design without moving parts (except for the transport systems used for the removal of the fly ash from the bottom) and, therefore, can have high availability at relatively low costs. However, the pressure drop of the flue-gas stream is relatively high, resulting in an increased power requirement for the flue-gas fan and therefore in additional energy consumption.

[2, InfoMil 2002] For the proper functioning of an ESP, it is important that the flue-gas stream is evenly distributed over its total surface. The pressure drop of the flue-gas over an ESP is low, reducing energy consumption. However, some pre-dedusting equipment (e.g. ESPs, filters) require electricity for their operation. [74, TWG 2004].

Table 4.11: Operational data associated with the use of pre-dedusting systems

Criteria	Description of factors affecting criteria	Evaluation (high/medium/low)	Comments
Complexity	<ul style="list-style-type: none"> Additional process units required Critical operational aspects 	M	The extra process unit adds complexity, but can simplify later operations
Flexibility	<ul style="list-style-type: none"> Ability of technique to operate under a range of input conditions 	H	Each of the systems can be applied to variable flue-gas flows and compositions
Skill requirements	<ul style="list-style-type: none"> Notable extra training or manning requirements 	H/M	Bag filters require the most attention, and cyclones the least; ESPs are in between
Other requirements	<ul style="list-style-type: none"> Bag filters may require addition of reagents for corrosion and fire protection 		

The table below provides a comparison of dust removal techniques (used at the pre- and post-dedusting stages):

Table 4.12: A comparison of dust removal systems

Dust removal technique	Typical dust emission concentrations	Advantages	Disadvantages
Cyclone and multi-cyclone	Cyclones: 200–300 mg/m ³ Multi-cyclones: 100–150 mg/m ³	- Robust, relatively simple and reliable - Applied in waste incineration	- Only for pre-dedusting - Relatively high energy consumption
Dry ESP	< 5–25 mg/m ³	- Relatively low power requirements - Can use gas temperatures in the range of 150–350 °C - Widely applied in waste incineration	- Risk of formation of PCDD/F if used in the 450–200 °C temperature range
Wet ESP	< 5–20 mg/m ³	- Able to reach low emission concentrations - Sometimes applied in waste incineration	- Little experience in waste incineration - Mainly applied post-dedusting - Generation of process waste water - Increase of plume visibility
Bag filter	< 5 mg/m ³	- Widely applied in waste incineration - The layer of residue acts as an additional filter and as an adsorption reactor	- Relatively high energy consumption (compared to ESP) - Sensitive to condensation of water and to corrosion
<i>Source:</i> [2, InfoMil 2002]			

Cross-media effects

Energy requirements of different pre-dedusting techniques are evaluated in the table below.

Table 4.13: Energy requirements associated with the use of various pre-dedusters

Pre-dedusting technique	Unit	Energy requirements	Comments
Cyclone	kWh/t waste input	Low	Lower efficiency for removal of particles < 5 µm
Multi-cyclone		Low	Common technology
Dry ESP		Higher (electrostatic loading)	
Bag filter		Highest by pressure drop and high-pressure pulse-jet cleaning	Common technology
<i>Source:</i> [74, TWG 2004]			

The most significant cross-media effects associated with this technique are:

- energy consumption due to pressure loss, which is higher with bag filters than for other systems;
- electricity consumption for ESP operation;
- flue-gas PCDD/F concentrations may increase during their residence time in the ESP, particularly when operated at temperatures between 200 °C to 450 °C.

Technical considerations relevant to applicability

Pre-dedusting requires space for the additional process unit, which may be a limiting factor for existing plants.

Economics

The key aspects of this technique are:

- increased capital and investment costs – for additional process units;
- increased energy costs, particularly for bag filtration;
- possible cost reductions for disposal where outlets are available for segregated fly ash;
- possible increased cost of handling additional residue streams (either for recovery or disposal).

Investment costs for a two-line MSWI with a total capacity of 200 000 t/yr are estimated as [12, Achternbosch, 2002]:

- ESP (3-field): EUR 2.2 million;
- ESP (2-field): EUR 1.6 million;
- bag filter: EUR 2.2 million (not clear if this includes an upstream flue-gas cooler).

The unit operational costs of a bag filter for pre-dedusting may be higher due to the higher energy use associated with the pressure drop and the reagent injection. However, the bag filter's greater removal capacity for dust and for other pollutants (particularly when used with reagent injection) can result in reduced costs for subsequent components of the FGC system.

Driving force for implementation

- The FGC residues and fly ash can be separated and treated/recycled separately.
- Smaller capacity downstream FGC equipment is required (dust loads are reduced).
- Improvements in the operation of downstream FGC systems.
- Preference for the removal of PCDD/F before wet scrubbing to reduce the memory effect.

Example plants

Widely applied in many incineration plants.

Reference literature

[2, InfoMil 2002], [55, EIPPCB 2002], [64, TWG 2003]

4.5.2.2 Downstream dedusting

Description

This technique relates to either one of the following cases:

- dedusting associated with dry and semi-wet processes in order to capture at the same time as dust the salts produced by the reaction between acid gases and alkaline reagents.
- the application of an additional flue-gas polishing system for the final reduction of dust emissions after other FGC components, before the final release of stack gases to the atmosphere.

Technical description

The main system used downstream of a dry or semi-wet FGC system is the bag filter.

The main systems used for flue-gas polishing are:

- bag filters;
- wet ESPs;
- electrodynamic Venturi scrubbers;
- aggro-filtering modules;
- ionising wet scrubbers.

[74, TWG 2004]

The individual techniques are described in Section 2.5.3.

The addition of a final wet flue-gas treatment system can also be considered a polishing treatment after other systems that deal with acid gases, etc. This addition is generally made to specifically control HCl and SO₂ emissions where they are highly variable; PCDD/F and mercury can also be removed with the use of carbon-impregnated polymer (plastic) material and with the addition of hydrogen peroxide respectively. These additional techniques are described in Sections 4.5.5.7, and 4.5.6.5. [64, TWG 2003] [7, TWG 2017]

Polishing devices are also implemented to remove droplets (especially fine ones). They are generally implemented to prevent fouling in downstream devices such as an SCR system. [74, TWG 2004]

Achieved environmental benefits

In addition to the further reduction of dust emissions, emissions to air of the following substances can also be reduced:

- metals – as their emission concentrations are usually associated with dust removal efficiency;
- mercury and PCDD/F – where carbon (usually with alkaline reagent) is added as an absorbent on bag filters;
- acid gases – where alkaline reagents are added to protect bag filters.

The benefits of these additional reductions may be small where upstream techniques are already being applied to reduce the concentrations in the flue-gas to a low level.

Furthermore, the use of two different systems for the removal of solids from the flue-gas enables the separation of fly ash from the FGC residues (salts from acid gas neutralisation). This may then allow the recovery of one or other fraction where suitable outlets exist.

Environmental performance and operational data

Generally, similar dust emission levels can be achieved with upstream and downstream dedusting.

In the case of double dedusting, further reductions of emissions to air beyond that already achieved by other FGC components are as shown in the table below.

Table 4.14: Emission levels associated with the use of BF flue-gas polishing systems

Substance	Achieved emission ranges			
	Half-hourly average (mg/Nm ³)	Daily average (mg/Nm ³)	Annual average (mg/Nm ³)	Specific emission (g/t waste input)
Dust	< 15	< 1–5	< 0.4	< 2.5
NB: The precise final emission level achieved will depend on the level at the inlet to the final dust removal stage (itself depending on the performance of the earlier stages applied) and the efficiency of the final dust removal stage used. The figures given here provide a guide to the sort of emission levels that are generally seen where a polishing stage is added. Source: [81, TWG 2016]				

Careful maintenance of bag filters is very important to ensure their effective operation and hence low emissions. The pressure drop across the bags is monitored in order to maintain a cake on the filter. It can also be used as a means to detect bag damage (such as irreversible fouling). Dust emissions can usually be controlled to a very low level, simply by observing the pressure drop more closely and adopting stricter criteria (i.e. less latitude allowed before maintenance action is taken) for bag replacement. Analysis of the filter media may also be used to assess the reagent dose rate required and to assess its condition and its remaining lifetime.

Table 4.15: Operational data associated with the use of flue-gas polishing

Criteria	Description of factors affecting criteria	Evaluation (high/medium/low)	Comments
Complexity	<ul style="list-style-type: none"> Additional process units required Critical operational aspects 	H	Additional process units add complexity
Flexibility	<ul style="list-style-type: none"> Ability of technique to operate under a range of input conditions 	M	As a tail-end technique, the process will be less subject to such variations
Skill requirements	<ul style="list-style-type: none"> Significant extra training or manning requirements 	H	Bag filters require careful maintenance

Cross-media effects

The cross-media effects associated with double dedusting are identified in the following table.

Table 4.16: Cross-media effects associated with the use of additional flue-gas polishing

Criteria	Comments
Energy requirements	Increased due to pressure drop across process unit
Reagent consumption	More reagent used
Water consumption	Wet ESP leads to water discharge, which may be recycled in the process
Residue – type	Fly ashes and/or other substances removed in the polishing filter generally become an additional solid waste stream
Residue – amount	Varies according to input loads and applied upstream FGC techniques but will generally be low
Plume visibility	Non-dry systems can increase plume visibility
<i>Source: [74, TWG 2004]</i>	

For this technique, the most significant cross-media effect is the consumption of energy due to the pressure drop across the bag filters.

In particular, in the case of using two bag filters in series (even if separated), the potential benefits in terms of improved pollutant control need to be contrasted against the significantly higher fan power required to overcome the additional pressure drop caused by the second bag filter, and therefore higher electricity consumption.

Technical considerations relevant to applicability

Flue-gas polishing (double dedusting) requires space for the additional process unit, which may be a limiting factor for existing plants.

Economics

The key cost aspects of double dedusting are:

- increased capital costs due to the additional process unit;
- increased operating costs – mainly due to energy requirements for the pressure drop, provision of compressed air for back pulsing of the bag filter (if used), and additional maintenance costs.

Driving force for implementation

Downstream dedusting is generally necessary when using dry or semi-wet FGC systems.

For the specific case of double dedusting, driving forces for its use may include:

- compliance with legislation/local permit conditions that require additional reductions of dust, metals, dioxin and/or acid gas emissions;
- need for effective dedusting for a subsequent SCR process;
- possibility to recycle the salts arising from the removal of acid gases;
- where double bag filtration is used, recovering additional heat between the two bag filters enables operating the second filter at a lower, optimal temperature (around 140 °C) for activated carbon injection.

Example plants

Downstream dedusting is applied at all plants fitted with dry or semi-wet FGC systems

There are examples of plants using double dedusting in Germany, Austria, France and the Netherlands.

Reference literature

[3, Austria 2002], [2, InfoMil 2002], [64, TWG 2003]

4.5.3 Techniques to reduce acid gas emissions

The sections that follow address:

- description and assessment of the performance generally achieved by the main techniques applied for acid gas reduction – including consideration of applicability to various situations;
- description and assessment of some other technological and procedural options relevant to acid gas removal.

4.5.3.1 Wet scrubbing systems

Description

This technique is described in Section 2.5.4.

Technical description

Wet scrubbers generally have at least two effective stages: the first at low pH removes mainly HCl and HF as well as metals, the second stage is dosed with milk of lime, limestone suspension or sodium hydroxide and operated at a pH of 6–8 primarily for the removal of SO₂. Scrubbers may sometimes be described as three or more stages – the additional stages generally being subdivisions of the first low pH stage for specific purposes.

Achieved environmental benefits

Wet FGC systems provide the highest removal efficiencies (for soluble acid gases) of all FGC systems with the lowest excess stoichiometric factors. [74, TWG 2004]

Whilst single-stage filtration-based FGC systems (e.g. semi-wet, dry) combine and collect residues together, this is not generally the case with wet systems. The wet systems can treat HCl, HF and SO₂ separately from dust, which is usually removed before. That said, wet systems do provide some additional reductions of the following substances:

- Dust - where the scrubber capacity is large enough to prevent clogging (most usually a pre-dedusting stage is used before the wet scrubber to reduce dust loads and prevent operational problems), by up to 50 % of the dust input. [74, TWG 2004]
- PCDD/F - if carbon-impregnated packing materials are used, a typical reduction of 70 % is achieved by a typical scrubbing system. However, multi-stage scrubbing systems packed with a sufficient volume of carbon-impregnated materials are able to guarantee emission levels well below 0.1 ng I-TEQ/ Nm³ in MSWIs and HWIs. Activated carbon or coke may be added to the scrubber for a similar purpose, with similar removal efficiencies. In the absence of carbon additives, the removal rates are negligible. [74, TWG 2004] [7, TWG 2017]
- Hg²⁺ - if a low pH (~1) first stage scrubber is used, and HCl concentrations in the waste provide for acidification of this stage, then mercury is removed as HgCl₂; elemental mercury is in general not affected. [64, TWG 2003]
- Other pollutants - when water-soluble pollutants like bromine and iodine are present in the raw gas, they may be condensed at the low temperatures in the scrubber and in this way enter the scrubber waste water.

Environmental performance and operational data

The air emission levels generally achieved by plants fitted with wet scrubbers are shown in Table 4.17.

Table 4.17: Emission levels associated with the use of wet scrubbers

Substance	Achieved emission ranges				Comments
	Yearly maximum of		Annual average (mg/Nm ³)	Specific emission (g/t waste input)	
	Half-hourly averages (mg/Nm ³)	Daily averages (mg/Nm ³)			
HCl	2–10	< 2–4	< 2	< 12	Very stable outlet concentrations
HF	< 1	< 1	< 0.5	< 3	Very stable outlet concentrations
SO ₂	10–50	5–30	< 10	< 60	Requires reaction stage and absorbent (milk of lime, limestone suspension, or sodium hydroxide)

Source: [81, TWG 2016]

Table 4.18: Operational data associated with the use of wet FGC

Criteria	Description of factors affecting criteria	Evaluation (high/medium/low)	Comments
Complexity	<ul style="list-style-type: none"> • Additional process units required • Critical operational aspects 	H	The number of process units is greater than other systems
Flexibility	<ul style="list-style-type: none"> • Ability of technique to operate under a range of input conditions 	H	Very robust – highest ability of all systems to achieve emission reduction of HCl/HF under fluctuating inlet concentrations
Skill requirements	<ul style="list-style-type: none"> • Notable extra training or manning requirements 	H	The associated effluent treatment plant requires a high skill input

The main operational issues are as follows.

PCDD/F build-up in wet scrubbers can be a problem, in particular from maintenance and start-up periods, and may require specific measures to be taken.

Effluent treatment requires highly skilled operation to achieve low emission levels.

For effective operation, wet scrubbers require flue-gases that have already been dedusted using for example an ESP or BF. [64, TWG 2003]

Wet scrubbing enables flexibility in terms of the variation in the inlet concentrations of HCl, HF and also SO₂ owing to its high buffer capacity. Sometimes additional treatment is required for mercury, for example: the injection of a complex builder in the basic scrubber; injection of activated carbon in the acidic scrubber; injection of oxidising agent or abatement in the gas phase with adsorbent. [64, TWG 2003]

Cross-media effects

Cross-media effects are identified in Table 4.19 below.

Table 4.19: Cross-media effects associated with the use of wet scrubber FGC

Criteria	Units	Range of values	Comments
Energy requirements	kWh/t waste input	19	Pumps increase electricity consumption. Additional energy is needed to evaporate the effluent where there is a need to avoid water discharges.
Reagent consumption	kg/t waste input	Depending on the reagent used: NaOH: 3–5 CaO: 2–4 Ca(OH) ₂ : 2–4 CaCO ₃ : 6–9	Lowest of all systems
Reagent stoichiometry	Ratio	1.0–1.2	Lowest of all systems
Residue – type			Effluent treatment sludge; in some cases HCl or gypsum may be recovered
Residue – amount	kg (wet)/t waste input kg (dry)/t waste input	10–15 3–5	Lowest of all systems. This figure does not include separately removed fly ash: approx. 16 kg/t input.
Water consumption	l/t waste input	100–500	Highest of all systems but can be reduced by treatment and recirculation /condensation and by low temperatures before scrubber inlet.
Effluent production	l/t waste input	0–500	Treatment required before discharge or reuse
Plume visibility	+/-	+	High gas moisture content, but can be reduced by reheat/condensation
NB: The data in this table aim to provide the typical operational range. The precise amounts of residues and effluents produced will depend on many factors including raw gas concentrations (waste-related), flow rates, reagent concentrations, etc. Source: [1, UBA 2001], [2, InfoMil 2002], [12, Achternbosch, 2002], [81, TWG 2016]			

For this technique, the most significant cross-media effects compared to other options are:

- lowest reagent consumption rates;
- lowest solid residue production rates;
- higher water consumption;
- production of an effluent that requires management;
- increased plume visibility;
- PCDD/F build-up (memory effect) on scrubber plastic components requires addressing;
- if the input temperature is too high the material used in the wet scrubber may be destroyed. [74, TWG 2004]

Technical considerations relevant to applicability

The technique is generally applicable as long as there is a sufficient water supply.

Due to the low outlet temperature (approximately 70 °C), the flue-gas may need to be reheated for subsequent FGC systems, e.g. bag filters and SCR.

Economics

Estimated capital costs for the technique are as in the table below.

Table 4.20: Estimated investment costs of selected components of wet FGC systems

FGC component	Estimated investment cost (million EUR)	Comments
Two-stage wet scrubber	5	Including waste water treatment
Three-stage wet scrubber	7	Including waste water treatment
External scrubber effluent evaporation plant	1.5–2	
Spray absorber for internal effluent evaporation	1.5	
NB: Costs estimated relate to a two-line MSWI with a total capacity of 200 kt/yr. Source: [12, Achternbosch, 2002], [74, TWG 2004]		

The key cost aspects of this technique compared to the alternatives are:

- higher capital investment costs than other systems, mainly due to the effluent treatment plant and the higher number of process units required, which may be a limiting factor in particular at smaller non-hazardous waste incineration sites;
- operational costs associated with disposal of residues may be lower, due to the lower specific residue production [74, TWG 2004];
- labour costs are higher due to the increased complexity of the system.

Driving force for implementation

- Achievement of particularly low and stable acid gas emission levels.
- Reduction of disposal costs for flue-gas treatment residues.
- Possibility to recover HCl, salt, gypsum.
- Particularly difficult to predict/control input waste composition.
- Input waste may contain high and variable loads of acid gas precursors or metals (e.g. ionic mercury) [74, TWG 2004].
- Reduction of ammonia emissions.

Example plants

Wet flue-gas scrubbing is widely used throughout Europe for the full range of waste types.

Reference literature

[1, UBA 2001], [2, InfoMil 2002], [12, Achternbosch, 2002], [64, TWG 2003]

4.5.3.2 Semi-wet scrubbing systems**Description**

This technique is described in Section 2.5.4.

Technical description

The diagram below shows a typical semi-wet FGC system, with a reactor on the left and downstream deduster on the right.

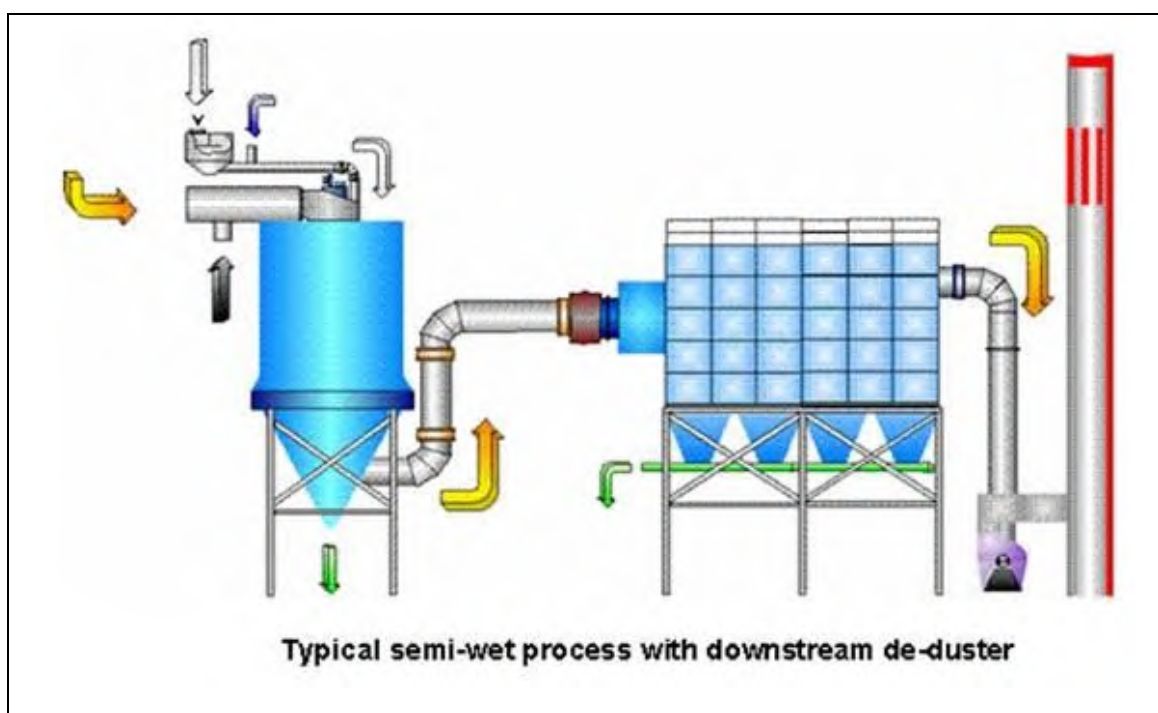

Figure 4.6: Typical design of a semi-wet FGC system

Achieved environmental benefits

There is no effluent discharge from semi-wet scrubbers as the amount of water used is generally lower than with wet scrubbers and it is evaporated with the flue-gases. If of suitable quality, other site waste water (e.g. rainwater) may be sent to the FGC system. [74, TWG 2004]

Semi-wet FGC systems provide high removal efficiencies (for soluble acid gases). Emission levels can be decreased by adjusting the reagent dosing rate and design point of the system, but generally at the cost of increased reagent consumption and residue production rates.

Semi-wet systems are used with fabric filters to remove the reagents added and their reaction products. Reagents, other than alkaline reagents, can also be added to adsorb other flue-gas components (e.g. activated carbon for mercury and PCDD/F).

They are most commonly used as a single-stage reactor/filter for the combined reduction of:

- acid gases - removed by the alkaline reagent;
- dust - filtered by the fabric filter;
- PCDD/F - adsorbed if activated carbon is injected as well as alkaline reagent;
- Hg - adsorbed if activated carbon is injected as well as alkaline reagent.

Environmental performance and operational data

The air emission levels generally achieved by plants fitted with semi-wet scrubbers are as follows.

Table 4.21: Emission levels associated with the use of semi-wet scrubbers

Substance	Achieved emissions				Comments
	Yearly maximum of		Annual average (mg/Nm ³)	Specific emission (g/t waste input)	
	Half-hourly averages (mg/Nm ³)	Daily averages (mg/Nm ³)			
HCl	12–25	2–8	< 6	< 33	Peaks can be dealt with by an upstream HCl analyser. The semi-wet process can capture SO ₂ at the same time as HCl and HF in the same scrubber.
HF	< 2	< 1	< 0.5	< 3	
SO ₂	30–70	< 40	< 25	< 140	

Source: [81, TWG 2016]

Table 4.22: Operational data associated with the use of semi-wet FGC

Criteria	Description of factors affecting criteria	Evaluation (high/medium/low) or data	Comments
Complexity	<ul style="list-style-type: none"> • Additional process units required • Critical operational aspects 	M	<ul style="list-style-type: none"> • The number of process units is lower than wet systems, but greater than dry • Inlet temperature requires control • Pre-dust removal may ease semi-dry operation
Flexibility	<ul style="list-style-type: none"> • Ability of technique to operate under a range of input conditions 	M	<ul style="list-style-type: none"> • Can achieve low emission levels under most conditions • Rapid inlet load changes can be problematic
Skill requirements	<ul style="list-style-type: none"> • Significant extra training or manning requirements 	M	<ul style="list-style-type: none"> • No effluent treatment requirements • Care required to optimise reagent dosing

Most systems consist of only a reagent mixing unit (reagent plus water) and a spray tower, and then a bag filter – complexity is therefore lower than with wet FGC systems.

The reagent handling and dosing require good management to ensure effective and optimised operation, particularly where heterogeneous waste types are treated, e.g. merchant HWIs.

Upstream HCl monitoring (see Section 4.5.3.9) improves optimisation of reagent dosing in these systems and allows management of peak loads of HCl, HF and SO₂ without high reagent dosing rates.

Some installations produce the Ca(OH)₂ for the FGC system on site by slaking of CaO. Effective lime preparation can be critical to good operation, as can be controlling the risk of fouling in the injection device. The injectors have to be located and designed such that they can be easily maintained and/or replaced for cleaning. [74, TWG 2004]

Bag filters require close monitoring and management to address bag damage and consequent releases. Differential pressure monitors are commonly used to indicate bag damage and monitor operation in general.

Temperature requirements are critical. Care is required to ensure dew point corrosion in the bag filter is avoided – inlet gas temperatures of above 130–140 °C are usually used. At temperatures below 130 °C there may be problems due to the hygroscopic nature of the CaCl₂ formed. Reagents usually require a specific temperature for optimal reaction conditions.

It is reported that there may be operational problems when semi-wet FGC systems are used with very highly acidic polluted raw gases as this can lead to an increased risk of filter clogging.

The operational complexity of reactors and bag filters used in semi-dry systems can itself be decreased further by the use of a degree of pre-dedusting, e.g. use of a single-stage ESP, or by using non-sticky bag materials (see also Section 2.5.3.5). This avoids the problems of:

- sticking of some zinc (and similar salts with low melting temperatures); and
- hygroscopic salts forming sticky layers on the surface of the reactor.

[64, TWG 2003]

Cross-media effects

Cross-media effects are identified in the following table.

Table 4.23: Cross-media effects associated with the use of semi-wet acid gas treatment

Criteria	Units	Range of achieved values	Comments
Energy requirements	kWh/t waste input	6–13	Pressure drop across bag filter creates energy demand
Reagent consumption	kg/t waste input	7–10 (quicklime)	Mid-range of system options applied
Reagent stoichiometry	Ratio	1.4–2.5	Lowest values achieved with recirculation / with low pollution load wastes
Residue – amount	kg/t waste input	25–50	Combined FGC and fly ash
Water consumption	l/t waste input	< 300	Lowest where FGC inlet temperature is low; otherwise water for cooling also necessary
Plume visibility	+/-	0	Mid-range of applied systems
NB: The data in this table aim to provide the typical operational range. The precise amounts of residues and effluents produced will depend on many factors including raw gas concentrations (waste-related), flow rates, reagent concentrations, etc. Source: [3, Austria, 2002], [12, Achternbosch, 2002], [64, TWG 2003], [74, TWG 2004], [81, TWG 2016]			

For this technique, the most significant cross-media effect is higher residue production rates than for wet systems.

Separate collection of fly ash is possible if this system is preceded by an ESP. This then increases separation of fly ash and FGC residues, which can be beneficial if separate treatment/recycling options exist for these residues.

The semi-wet FGC system is often applied as a single-stage multi-reactor. Such systems usually have lower energy requirements than more complex multistage FGC systems.

Technical considerations relevant to applicability

The technique is generally applicable.

Due to the outlet temperature (120–170 °C), the flue-gas may need to be reheated for some subsequent FGC systems, e.g. SCR.

Economics

Capital cost information for the technique is shown in the table below.

Table 4.24: Estimated investment costs of selected components of typical semi-wet FGC systems

FGC component(s)	Estimated investment cost (million EUR)
Fabric filter	2
Spray dryer	1–1.5
NB: Costs estimated relate to a two-line MSWI with a total capacity of 200 kt/yr. Source: [12, Achternbosch, 2002]	

Key operational factors of this technique are:

- investment costs are lower than for wet FGC systems, especially for relatively small capacities [2, InfoMil 2002]; possible higher cost of disposal of the higher quantity of residues produced (than wet systems);
- reduced labour cost (compared to wet systems) due to the lower complexity, particularly because it avoids the costs of operating an effluent treatment plant;
- increased alkaline reagent cost due to higher stoichiometric ratios.

Driving force for implementation

- Capability to deal with moderate and moderately variable inlet flue-gas loads.
- No production of effluent.
- Lower investment cost than for a wet scrubber.
- Water consumption lower than for a wet scrubber.
- Lower plume visibility than with wet systems. [64, TWG 2003]

Example plants

Widely used in Europe, e.g. the UK, Germany, France and Denmark.

Reference literature

[1, UBA, 2001] [2, InfoMil 2002] [3, Austria, 2002] [12, Achternbosch, 2002] [26, RSP 1999], [54, dechefdebien, 2003] [64, TWG 2003]

4.5.3.3 Dry FGC systems

Description

This technique is described in Section 2.5.4.

Technical description

Lime (e.g. hydrated lime, high specific surface area lime) and sodium bicarbonate are commonly used as the alkaline reagents. The addition of activated carbon provides for the reduction by adsorption of mercury and PCDD/F emissions.

Finely ground sodium bicarbonate, when injected into hot gases (above 160 °C), is converted to sodium carbonate of high porosity and hence is effective for acid gas absorption. [59, CEFIC 2002], [7, TWG 2017]

Achieved environmental benefits

With this technique, it is generally not possible to reach the same very low emission levels as with other FGC systems without increasing reagent dosing rates and consequent residue generation. Reagent recycling can reduce these cross-media effects to some degree, but can lead to operational difficulties related to reagent dosing systems.

Environmental performance and operational data

Technical developments have enabled significant improvements over the last decade in the performance of dry systems.

The air emission levels generally achieved by plants fitted with dry FGC are as follows.

Table 4.25: Emission levels associated with the use of hydrated lime in dry FGC processes

Substance	Achieved emission ranges			
	Yearly maximum of		Annual average (mg/Nm ³)	Specific emission (g/t waste input)
	Half-hourly averages (mg/Nm ³)	Daily averages (mg/Nm ³)		
HCl	10–30	5–8	< 6	< 33
HF	< 0.6	< 0.3	< 0.2	< 1.2
SO ₂	20–70	10–40	< 15	< 85

Source: [81, TWG 2016]

Table 4.26: Emission levels associated with the use of sodium bicarbonate in dry FGC processes

Substance	Achieved emission ranges			
	Yearly maximum of		Annual average (mg/Nm ³)	Specific emission (g/t waste input)
	Half-hourly averages (mg/Nm ³)	Daily averages (mg/Nm ³)		
HCl	6–30	< 2–8	< 6	< 33
HF	< 1.2	< 1	< 0.5	< 3
SO ₂	30–50	5–25	< 15	< 85

Source: [81, TWG 2016]

Table 4.27: Operational data associated with the use of dry FGC

Criteria	Description of factors affecting criteria	Evaluation (high/medium/low) or data	Comments
Complexity	<ul style="list-style-type: none"> Additional process units required Critical operational aspects 	L	<ul style="list-style-type: none"> Simple process of few components
Flexibility	<ul style="list-style-type: none"> Ability of technique to operate under a range of input conditions 	M/L	<ul style="list-style-type: none"> Wide operational temperature range
Skill requirements	<ul style="list-style-type: none"> Notable extra training or manning requirements 	M/L	<ul style="list-style-type: none"> Simple system Bag filter requires effective management

Source: [59, CEFIC 2002]

Dry reagents need to be handled in such a manner as to prevent dust emissions, e.g. emissions from loading silo breather vents.

Some installations produce the $\text{Ca}(\text{OH})_2$ for the FGC system on site by slaking of CaO . Effective lime preparation can be critical to good operation, as can be controlling the risk of fouling in the injection device. The injectors have to be located and designed such that they can be easily maintained and/or replaced for cleaning. [74, TWG 2004], [7, TWG 2017]

It is reported that the use of operating temperatures above approximately 210 °C may give rise to a deterioration in the PCDD/F and mercury adsorption performance of injected carbon reagents. [7, TWG 2017]

Cross-media effects

Cross-media effects are identified in the table below.

Table 4.28: Cross-media effects associated with the use of dry FGC

Criteria	Units	Range of achieved values	Comments
Energy requirements	kWh/t waste input		Mainly from pressure drop across bag filter. Higher operational temperature can lead to savings for FG reheat.
Reagent consumption	kg/t waste input	10–20 (CaO) 6–12 (NaHCO ₃)	Mid-range of system options applied
Reagent stoichiometry	Ratio	1.05–1.2 (NaHCO ₃) 1.5–2.5 (Ca(OH) ₂)	Optimisation of the technique over the last decade has allowed the reduction of the excess to 5–20 % with sodium bicarbonate. Lower values with hydrated lime achieved with recirculation.
Residue	kg/t waste input	7–25	From 1 tonne MSW (does not include boiler ash)
Plume visibility	+/-	-	Lowest of all systems

NB: *In situ* operational values will vary depending upon local variations in waste type, etc.
Source: [64, TWG 2003]

The most significant cross-media effect of this technique is the production of solid residues, which, all other parameters being equal, is generally greater than with wet systems. The excess may be reduced somewhat by residue recirculation.

With sodium bicarbonate, the solid residues are more soluble than with hydrated lime, but significantly lower in quantity. Residues from bicarbonate systems, if separated from the fly ashes, may be treated and recycled in the chemical industry (established practice in France and Italy). [74, TWG 2004], [7, TWG 2017]

Technical considerations relevant to applicability

The technique is generally applicable.

Economics

Capital cost and system design considerations:

- lower capital costs than for semi-wet systems;
- higher possible operating temperatures can lead to savings for flue-gas reheating, e.g. for SCR;
- reagent slurry handling/mixing unit not required with dry systems.

Operating cost considerations relative to other techniques:

- increased reagent consumption rates, compared to wet FGC;
- increased disposal costs for residues, compared to other FGC systems;
- savings for treatment/disposal because of lack of effluent.

Driving force for implementation

The simplicity of such systems is the main reason for their use.

The lower energy consumption compared to other FGC options, and the lower possible boiler outlet temperatures allowed by the absence of a temperature drop in dry FGC, also make these systems attractive from the point of view of energy recovery.

Restrictions on water supply and outlets make the use of dry FGC systems favourable. When water discharges are forbidden, dry (and semi-dry) systems are favoured.

Dry systems provide further advantages where a visible plume has to be avoided.

Example plants

The technique is widely used throughout Europe. Over 240 plants are operating in more than 10 European countries, and Japan and the US.

There are examples of merchant HWIs using dry systems in France and Germany.

Reference literature

[59, CEFIC 2002], [2, InfoMil 2002], [64, TWG 2003]

4.5.3.4 Addition of wet scrubbing as a flue-gas polishing system after other FGC techniques

Description

It is possible to consider that the addition of a final wet flue-gas treatment system, or flue-gas condensation, is a polishing treatment after other systems that deal with acid gases, etc. This addition is generally made to control HCl and SO₂ emissions where they are high or variable. [74, TWG 2004]

Technical description

Flue-gas polishing is typically performed in packed bed wet scrubbers. A usual feature of wet scrubbing in the polishing position is that HCl, SO₂, HF and possibly mercury can be removed

in one common stage rather than in two separate stages. NaOH can be added to improve the removal of SO₂ and HF. The process water may be injected into the furnace or into the upstream dry flue-gas cleaning system for waste-water-free operation. Energy recovery by condensation can be integrated into the system, and the occurrence of wet plume can be avoided by reheating the flue-gas by the addition of a steam heater or by a gas-gas heat exchanger without the need for an additional energy supply.

Achieved environmental benefits

Increased reliability in acid gas (HCl, HF, SO₂) emission reductions down to levels at the lower end of the ranges achievable with wet scrubbing (see Section 4.5.3.1).

The consumption of sorbent and the related production of residues in the upstream dry system may be decreased due to the high efficiency and low stoichiometric factor of the polishing scrubber.

Environmental performance and operational data

See Section 4.5.3.1.

Cross-media effects

See Section 4.5.3.1.

Technical considerations relevant to applicability

See Section 4.5.3.1.

Economics

The typical investment cost reported for a scrubber sized for treating a 100 000 Nm³/h gas flow is EUR 2 million including circulation pumps. An additional investment of around EUR 100 000 may also be required for a reheater or fiberglass-reinforced plastic stack pipe.

Operating costs have been reported as EUR 10–15/h for electricity (additional fan pressure drop of typically 1 200 Pa) and circulation pump operation. The NaOH cost depends on the design.

See also Section 4.5.3.1.

Driving force for implementation

See Section 4.5.3.1 for the driving forces for the use of wet FGC in general.

Where emissions of acid gases are high or variable, the addition of a polishing stage may be driven by legislation requiring improved flue-gas cleaning related to peak concentrations of pollutants. The technique is thus most suited to wastes that have high and variable concentrations of chlorine or other acid-forming components (e.g. hazardous wastes or MW that includes industrial wastes).

The addition of a polishing stage may also be driven by savings in reagent costs in the upstream dry flue-gas cleaning system.

Example plants

Many plants in Scandinavia and WTE ACCAM Busto Arsizio (IT) (IT01); Usine de Fort-De-France (FR) (FR46); Halluin (FR) (FR92).

Reference literature

[64, TWG 2003], [97, Denmark et al. 2015]

4.5.3.5 Recirculation of FGC residues in the FGC system

Description

Residues collected in the bag filters used for dry, semi-wet and similar (but not wet) FGC systems (see also Sections 4.5.3.2, 4.5.3.3 and 4.5.3.8) usually contain a significant proportion of unreacted flue-gas treatment reagents, as well as the fly ash and other pollutants removed from the gas stream. A proportion of the accumulated residues can be reactivated and recirculated within the FGC system.

Technical description

Because of the recirculation, the size of the FGC is generally increased to accommodate the additional volume of recirculating material.

The technique is particularly beneficial in the case of techniques that operate with a higher stoichiometric excess, and less relevant for the more efficient once-through system in which little unreacted reagent remains without recirculation. Analyses of the FGC residues may be carried out to determine the proportions of reacted and unreacted reagent.

The reactivation of unreacted reagents before reuse in the FGC process may take place by:

- water addition and high residue recirculation rates;
- low-pressure steam addition and medium residue recirculation rates;
- maturation of unreacted reagents and fly ash before recirculation into the FGC process.

Achieved environmental benefits

The recirculation of reagents within the system, combined with water/low-pressure steam addition or maturation, has the following advantages:

- reduced reagent consumption (compared to dry and semi-wet systems);
- reduced solid residue production (contains less unreacted reagent);
- improved control of acid gas peaks (the recirculation results in a higher reagent buffer).

These techniques are reported to be able to cope with the inlet concentrations associated with most waste types, including variable inlet concentrations that may arise for instance when incinerating merchant hazardous wastes.

Environmental performance and operational data

Table 4.29: Operational data associated with the use of residue recirculation

Criteria	Description of factors affecting criteria	Evaluation (high/medium/low)	Comments
Complexity	<ul style="list-style-type: none"> • Additional process units required • Critical operational aspects 	M	<ul style="list-style-type: none"> • Little additional equipment necessary • Care required to ensure effective circulation of reagent and humidity control
Flexibility	<ul style="list-style-type: none"> • Ability of technique to operate under a range of input conditions 	H/M	<ul style="list-style-type: none"> • Large buffer volume of circulating reagent increases flexibility • Not as flexible in respect of inlet variations as wet systems, but significantly more than dry systems without recirculation
Skills required	<ul style="list-style-type: none"> • Notable extra training or manning requirements 	M/L	<ul style="list-style-type: none"> • Simple systems

Source: [57, Alstom 2003], [64, TWG 2003]

Reagent injection and residue bleed rates require optimisation to prevent adsorbent loading and eventual substance breakthrough (e.g. mercury and PCDD/F adsorbed on carbon).

Moisture levels require monitoring and control to maintain the acid gas adsorption efficiency. Upstream HCl and SO₂ monitoring is used to optimise alkaline reagent/water/low-pressure steam dose rates.

Some parts of the FGC system volume must be larger to incorporate the additionally recirculated material.

The reduction of emissions to air and emission levels achieved with these processes in combination with a bag filter and addition of reagent, are as follows.

Table 4.30: Emission levels associated with the use of intermediate systems

Substance	Reduction efficiency range (%)	Achieved emission ranges				Comments
		Yearly maximum of		Annual average (mg/Nm ³)	Specific emission (g/t waste input)	
		Half-hourly averages (mg/Nm ³)	Daily averages (mg/Nm ³)			
HCl	> 99	< 10	< 6	2.9	10–30	Stable due to high circulation rate
HF	> 99.5	< 2	< 1	< 0.5	1–5	Stable due to high circulation rate
SO ₂	> 99	< 50	< 5	< 1	5–50	Stable due to high circulation rate

Source: [57, Alstom 2003], [64, TWG 2003] [74, TWG 2004]

Cross-media effects

This technique enables the reduction of the amount of solid residues produced, as it is lower than without recirculation.

The reported reagent stoichiometry is in the range 1.5–2.5 depending on the implemented technology. A lower stoichiometric excess is achieved with low-pressure steam than with water addition or maturation.

Water/low-pressure steam consumption depends on the inlet flue-gas temperature.

Plume visibility is very low due to the minimal amount of water/low-pressure steam used for conditioning.

In some cases, increases in mercury releases have been reported. Consideration of the mercury input rates and the provision of sufficient mercury removal may therefore be required to control this.

Technical considerations relevant to applicability

The technique is generally applicable in combination with FGC systems other than wet systems.

The recirculation of FGC residues requires a larger bag filter and additional space to accommodate the recirculation/reactivation/maturation equipment.

Economics

Capital costs are reported to be somewhat lower than for wet and semi-wet systems due to the reduced number of process components and consequently the smaller footprint, but slightly higher than for dry FGC without recirculation.

Operating costs, compared with dry FGC without recirculation, are reduced by the lower reagent consumption (improved stoichiometric ratio compared with dry systems) and the reduced residue disposal costs.

Driving force for implementation

- Reduction of reagent consumption.
- Reduction of residue production.
- Limited space requirements.
- Limited process complexity.

Example plants

Existing plants incinerating MSW, RDF and wood wastes in France, the UK, Italy, Sweden, Norway, Germany, Denmark and Spain.

Reference literature

[57, Alstom 2003], [64, TWG 2003], [7, TWG 2017]

4.5.3.6 Direct addition of alkaline reagents to the waste (direct desulphurisation)**Description**

This technique is described in Section 2.5.4.4. It is generally only applied to fluidised bed furnaces.

The alkaline reagent reacts in the furnace with acid gases to reduce the acid loads in the raw flue-gas passing to subsequent flue-gas cleaning stages.

Technical description

Adsorption within the furnace at high temperatures is much more effective for SO₂ than for HCl; the main applications are therefore processes with a relatively high SO₂ content, e.g. sludge incineration.

[74, TWG 2004]

Achieved environmental benefits

Benefits include some reduction of raw gas loads and the reduction of emissions and reagent consumption associated with the downstream FGC system.

Environmental performance and operational data

The main advantage of this technique is that it may reduce corrosion problems in the boiler. As the stoichiometric ratio is relatively high, it does not improve the overall FGC performance.

[64, TWG 2003]

Cross-media effects

For this technique, the most significant cross-media effects are:

- consumption of reagents in the furnace (but reduced consumption downstream);
- effects on the bottom ash quality since salts and the excess reagent are mixed with it;
- changing the composition of the flue-gas (SO₂ to HCl ratio) can affect the performance of downstream FGC systems, can alter the PCDD/F profile and can cause corrosion problems in the FGC.

The addition of hydrated lime will not only affect the bottom ash quality, but also the composition and resistivity of the fly ash (i.e. there will be more Ca and more sulphurous compounds and higher dilution of pollutants with an increasing amount of FGC residues). [64, TWG 2003]

Technical considerations relevant to applicability

The technique is generally applicable to fluidised bed systems.

Economics

The reduced flue-gas treatment costs need to be considered against the costs of adding the reagent at the earlier stage.

There are additional capital costs for the provision of reagent injection into the furnace/waste.

Driving force for implementation

The technique is implemented as a retrofit at existing plants where there is only a limited possibility to increase the acid gas cleaning capacity of the FGC systems.

Example plants

SOGAMA, Cerceda (ES) (ES07.1/ES07.2); Area Impianti Bergamo (IT) (IT07); SNB, Moerdijk (NL) (NL06).

Reference literature

[1, UBA 2001], [64, TWG 2003]

4.5.3.7 Boiler injection of alkaline reagents (high-temperature injection)

Description

Direct injection of dedicated reagents into the boiler at high temperature, in the boiler post-combustion area, to achieve partial abatement of the acid gases. Hydrated lime and dolime have been used as reagents.

Technical description

In this technique, the hydrated lime reagent is injected and reacts with the acid gases directly in the furnace, at optimal temperatures of 800–1 200 °C, to reduce the raw gas acid loads passing to subsequent flue-gas cleaning stages. Since adsorption at high temperatures is highly efficient for SO_x and HF removal, this reaction consumes significantly less reagent compared to achieving an equal removal rate at a lower temperature at the stage of the bag filter. The technique also flattens pollutant peaks, allowing the further reduction of reagent use in the downstream flue-gas cleaning unit.

Achieved environmental benefits

Benefits are reduction of raw gas loads and reduction of acid gas peaks, and reduction of emissions and reagent consumption in the downstream flue-gas cleaning unit.

Environmental performance and operational data

The reduction of SO₂, SO₃ and HF by 80–96 % and of HCl by 25–30 % (at the exit of the boiler) is reported with an injection rate of 3–8 kg hydrated lime per tonne of waste.

Cross-media effects

Since an overall reduction in the use of reagents in the combined in-boiler and downstream flue-gas cleaning systems is reported, no cross-media effects are expected.

Technical considerations relevant to applicability

The technique is generally applicable to grate and rotary kiln plants.

Economics

Investment costs are reported to be in the range of EUR 100 000–300 000.

Operating costs, including maintenance and energy costs for the conveying system and reagent costs for boiler injection, are EUR 0.4–2.20 per tonne of waste.

Avoided operating costs in the case of downstream NaHCO₃ sorbent injection are EUR 0.72–2.04 per tonne of waste.

Driving force for implementation

- Allowance of increased input loads of acidic pollutants in the waste.
- Reduction of boiler maintenance downtime.
- Reduction of the occurrence of acid gas emission peaks.
- Increase of the reliability of the FGC system by adding an additional step.
- As a retrofit, the technique can provide a simple upgrade of the existing FGC unit to increase the removal rate of acidic pollutants while keeping the reagent dosage rate moderate.

Example plants

ACSM S.p.A., Como (IT) (IT02); AMSA S.p.A. Milano (IT); REA Dalmine (IT) (IT10.1/IT10.2); Silea S.p.A, Valmadrera (IT) (IT11); Tecnoborgo S.p.A., Piacenza (IT) (IT12); Ambiente 2000 Trezzo Adda (IT); Brianza Energia Ambiente-Desio (IT) (IT03); AEM Gestioni Cremona (IT); ACCAM S.p.A., Busto Arsizio (IT) (IT01); Ecolombardia 4 Filago (IT); Schwandorf MWI (DE); Heringen RDF plant (DE) (DE50).

Reference literature

[99, EuLA 2015]

4.5.3.8 Combination of semi-wet absorber and dry injection system

Description

Combination of a semi-wet process (generally SDA) and of dry sorbent injection (DSI). The technique is also known as the three-quarters dry system.

Technical description

The technique consists of the injection of a dry reagent (DSI) upstream or downstream of the semi-wet reactor.

The reagent of the DSI can be hydrated lime, high-surface hydrated lime, high-porosity hydrated lime or a blend of hydrated lime and carbonaceous or mineral materials.

The basic principle of operation is to keep the injection of milk of lime in the reactor constant at the optimal design rate to capture most of the pollutant load, while the DSI is used to remove the residual acidic gas load including peaks by means of direct regulation control.

Achieved environmental benefits

- Reduction of the overall pollutant load released into air compared to a typical semi-wet process.
- Reduction of the quantity of residues generated thanks to improved stoichiometry compared to reaching the same removal rate with a semi-wet process alone.

Environmental performance and operational data

Reported removal efficiencies are > 98 % for SO₂ and > 99 % for HCl.

Reported advantages are:

- constant operation of the milk of lime preparation;
- fast and accurate response of the DSI to peak pollutant loads;

- redundancy of equipment for maintenance purposes;
- reduction of total reagent consumption (at equal acid gas removal rate) compared to the semi-wet process alone.

Cross-media effects

Since an overall reduction in the use of reagents compared to the use of SDA alone is reported at the same pollutant removal rate, no cross-media effects are expected.

Technical considerations relevant to applicability

The technique is applicable to new plants and to existing plants using SDA as the FGC process.

Economics

Investment costs are EUR 100 000–200 000 for a DSI system.

Operating costs, including maintenance and energy costs for the conveying system and reagent costs (1 kg hydrated lime per tonne of waste) for DSI, are EUR 0.17–0.29 per tonne of waste.

Avoided operating costs by reducing reagent consumption in the SDA unit are EUR 0.33–0.38 per tonne of waste, based on reducing lime consumption from 10 kg to 7.5 kg per tonne of waste.

Driving force for implementation

- As a retrofit, to enable a plant fitted with SDA to further reduce emission levels.
- Allowance of increased input loads of acidic pollutants in the waste.
- Savings in operating costs.

Example plants

Intradel Uvelia-Herstal (BE) (BE04); SNVE, Rouen (FR); BSR, Berlin (DE); IPALLE, Thumaide (BE); Vattenfall IKW, Ruedersdorf (DE) (DE84); SWB MHKW, Bremen (DE) (DE39); SERTRID Usine de Bourgogne (FR); IBW, Virginal (BE); Amagerforbraending, Copenhagen (DK); Slagelse Forbrændings Anlæg, Slagelse (DK) (DK03).

Reference literature

[100, EuLA 2015]

4.5.3.9 Use of acid gas monitoring for FGC process optimisation

Description

By using fast-response HCl, SO₂, and possibly also HF monitoring upstream and/or downstream of dry and semi-wet FGC systems, it is possible to adjust the operation of the FGC system so that the quantity of alkaline reagent used is optimised for the emission set point of the operation.

Technical description

The technique is generally applied as an additional method to control peak concentrations, with the build-up of a layer of reagent on the bag filters also providing an important buffering effect for reagent fluctuations.

This technique is not relevant to wet scrubbers as the scrubbing medium is water and the supply of water to a wet scrubber is controlled by the evaporation and bleed rates, not by the raw HCl concentration. [64, TWG 2003]

Just preventing HCl breakthrough is not always sufficient to ensure for all FGC systems that enough reagent is available to also provide for SO₂ and/or HF control and, therefore, reduce peak emissions. [7, TWG 2017]

Achieved environmental benefits

Benefits of the technique are that:

- peak raw gas loads are anticipated and therefore do not result in elevated emissions to air;
- neutralisation reagent consumption can be reduced by matching the demand;
- the amount of unused reagent in residues is reduced.

These environmental benefits are highest where waste quality control at the input to the furnace is limited, and lower where wastes are homogenised and subjected to good-quality control by means of selection, mixing or pre-treatment operations.

Smaller plants may benefit the most as rogue waste inputs can exert a larger influence on smaller throughput systems.

Environmental performance and operational data

The response time of the monitor needs to be fast to pass the control signal to the reagent dosing equipment in time to provide an effective response.

Where the monitors are located upstream of the FGC system, their resistance to corrosion is essential because of the extremely aggressive environment. Fouling can also be a problem.

The variation in the absorption capacity in the FGC system can be achieved by:

- changing the flow rate using variable speed pumps or variable speed dosing screws;
- changing the reagent concentration in semi-wet systems – where the mixing tank volume is small enough to ensure an adequate concentration change rate;
- adjusting the ratio of the reagents in FGC systems where multiple reagents or multiple FGC steps are used.

Cross-media effects

None reported.

Technical considerations relevant to applicability

The technique is generally applicable.

Economics

No information provided.

Driving force for implementation

- As a retrofit at existing plants, to avoid exceeding short-term emission limits.
- In the design of new plants, to optimise reagent consumption while ensuring compliance with short-term emission requirements.

Example plants

Applied at incinerators across the EU, e.g. Vitre (FR) (FR002); Cergy, Saint-Ouen L'Aumône (FR) (FR075); MHKW Bremerhaven, Breme (DE) (DE39); MKVA Krefeld (DE) (DE55.2R); UTE-TEM, Mataró (ES) (ES04); Allington Incinerator (UK) (UK07); Lincoln (UK) (UK12).

Reference literature

[17, ONYX 2000], [64, TWG 2003]

4.5.4 Techniques to reduce nitrogen oxide emissions

Primary techniques are generally of great importance for reducing the formation of NO_x at the combustion stage. The more general ones are described in Sections 4.1 and 4.3 and relate mainly to the management and preparation of wastes, and particularly to the thermal treatment techniques applied. This section of the BREF deals with the techniques that are applied for the reduction of NO_x emissions by the application of more NO_x-specific primary techniques, in Sections 4.5.4.1 and 4.5.4.2, and of secondary (abatement) techniques, in Sections 4.5.4.3, 4.5.4.4 and 4.5.4.5. In general, combinations of primary and secondary techniques are applied.

4.5.4.1 Low-NO_x burners for liquid wastes

Description

The technique is based on the principles of reducing peak flame temperatures. These burners are designed to delay but improve the combustion and increase the heat transfer (increased emissivity of the flame). The air/fuel mixing reduces the availability of oxygen and reduces the peak flame temperature, thus retarding the conversion of fuel-bound nitrogen to NO_x and the formation of thermal NO_x, while maintaining a high combustion efficiency.

[110, COM 2016].

Technical description

Descriptions of low-NO_x burners used for conventional fuels are given in the LCP BREF (note: these may require specific modifications for use with wastes).

Achieved environmental benefits

Reduced NO_x emissions to air.

Environmental performance and operational data

There are relatively few examples where low-NO_x burners are successfully used with wastes. Particular attention is required to ensure an adequate combustion efficiency (with waste). The technique is only applicable to specific liquid waste streams. It may be suited to some liquid hazardous wastes.

Cross-media effects

The use of low-NO_x burners may increase the risk of emissions of products of incomplete combustion (CO and organic substances).

Technical considerations relevant to applicability

Only applicable to the incineration of liquid waste.

Economics

The installation of low-NO_x burners during plant construction helps reduce the production of NO_x while adding little to the capital cost. The cost of retrofitting such burners to existing plants, however, can be higher. [64, TWG 2003]

Driving force for implementation

Reduction of NO_x emissions.

Example plants

Drehrohrofenanlage Schkopau (DE) (DE22); Reststoffverwertungsanlage, Stade (DE) (DE23); Sonderabfallverbrennungsanlage, Brunsbüttel (DE) (DE28); Vantaan Jätevoimala, Vantaa (FI) (FI05); CIE, Creteil (FR) (FR087.3); Four d'incinération John Zink, Chalampé (FR) (FR106); WIP Sarpi Dabrowa Gornicza, Dąbrowa Górnicza (PL) (PL03); Veolia High Temperature Incineration Plant, Ellesmere Port (UK) (UK01).

Reference literature

[110, COM 2016]

4.5.4.2 Replacement of secondary air with recirculated flue-gas

See Section 4.3.6.

4.5.4.3 Selective non-catalytic reduction (SNCR)

Description

See description in Section 2.5.5.2.1.

Technical description

[2, InfoMil 2002] In the SNCR process, ammonia (NH_3) or urea ($\text{CO}(\text{NH}_2)_2$) is injected into the furnace to reduce NO_x emissions. The NH_3 reacts most effectively with NO_x between 850 °C and 950 °C, although temperatures of up to 1 050 °C are effective when urea is used. If the temperature is too high, a competing oxidation reaction generates unwanted NO_x . If the temperature is too low, or the residence time for the reaction between NH_3 and NO_x is insufficient, the efficiency of NO_x reduction decreases, and the emission of residual ammonia can increase. Some ammonia slip will always occur because of reaction chemistry. Additional ammonia slip can be caused by excess or poorly optimised reagent injection. [74, TWG 2004]

In advanced SNCR designs the reaction temperature is optimised by a computer-controlled injection system with multiple lances distributed at different levels in the boiler. The temperature profile is measured by an acoustic or IR pyrometer and divided into sections that can be assigned to individual lances or groups of lances depending on the gas temperature measured. This ensures that the reagent is always injected at the most effective position in the boiler even with a rapidly varying and asymmetric temperature profile, resulting in lower NO_x levels with optimised reagent consumption and minimised ammonia slip [106, HWE 2015], [108, Sweden 2016].

Achieved environmental benefits

Benefits include the reduction of NO_x emissions at a substantially lower cost than SCR.

Environmental performance and operational data

Emission reductions and the levels of emissions to air generally achieved by plants fitted with SNCR are as follows.

Table 4.31: Emission levels associated with the use of SNCR

Substance	Achieved emission ranges				Comments
	Yearly maximum of		Annual average (mg/Nm^3)	Specific emission (g/t waste input)	
	Half-hourly averages (mg/Nm^3)	Daily averages (mg/Nm^3)			
NO_x	155–300	80–180	70–180	390–1 000	Varies with dosing rate, waste and combustor type
NH_3	5–60	3–15	1–6	6–33	Lowest where wet scrubbers are used.

Source: [1, UBA 2001], [2, InfoMil 2002], [12, Achternbosch 2002], [60, Reimann 2002], [81, TWG 2016]

The main source of N_2O emissions in SNCR is the use of urea instead of ammonia (leading to 2–2.5 times higher N_2O emissions than in the case of reduction by ammonia). To reduce N_2O formation, it is therefore important to optimise the reactant choice (ammonia or urea) and to control the process conditions (especially gas mixing, temperature and ammonia slip) [64, TWG 2003].

Table 4.32: Operational data associated with the use of SNCR

Criteria	Description of factors affecting criteria	Evaluation (high/medium/low)	Comments
Complexity	<ul style="list-style-type: none"> Additional process units required Critical operational aspects 	M	<ul style="list-style-type: none"> Reagent injection equipment required but not separate reactors (compared to SCR) Temperature and reagent injection optimisation important
Flexibility	<ul style="list-style-type: none"> Ability of technique to operate under a range of input conditions 	M	<ul style="list-style-type: none"> Good NO_x reduction across a range of inlet concentrations Temperature critical
Skill requirements	<ul style="list-style-type: none"> Notable extra training or manning requirements 	M	<ul style="list-style-type: none"> Care required to control and optimise injection rates
<i>Source: [64, TWG 2003]</i>			

The main factors influencing performance are:

- the mixing of the reactants with the exhaust gases;
- the temperature; and
- the residence time in the appropriate temperature window.

Increasing the reagent dose rates generally results in decreased NO_x emissions. However, this can increase ammonia slip and N₂O emissions (particularly with urea). When using urea, the process optimisation may pose additional challenges to ensure low ammonia slip.

The ammonia slip is absorbed if wet scrubbers are used. It can also be removed from the effluent stream using an ammonia stripper – although this adds complexity to the operation, and increases capital and operating costs [74, TWG 2004]. The regenerated ammonia can then be used as feedstock for the SNCR process (see also comment under Cross-media effects regarding effluent discharges if made).

Generally, N₂O concentrations increase as NO_x concentrations decrease. Under unfavourable conditions, levels of over 50 mg/m³ can be reached, whereas, under favourable conditions, emission concentration levels are below 10 mg/m³. To reduce N₂O formation, it is therefore important to optimise and control process conditions.

The amount of injected NH₃ depends on the NO_x concentration in the raw flue-gas, as well as on the required NO_x reduction. NH₃ is introduced into the flue-gas by injection of an aqueous solution. In some specific cases, the incineration of high-moisture sewage sludge has been reported to lead to significant NH₃ concentrations in the raw flue-gas, negating the need to inject NH₃. The most commonly used solutions are (concentrated or diluted) caustic ammonia (NH₄OH) or urea (CO(NH₂)₂). The use of urea is effective for relatively small units, as urea can be stored as a solid (in bags) and the operational and safety requirements related to the storage of ammonia are avoided. For larger units, the use of ammonia is generally more effective.

Effective mixing of reagents and NO_x in the flue-gas at the optimum temperature is essential to reach a high NO_x removal efficiency. In order to achieve the optimum temperature and to compensate for fluctuations in temperature, several sets of injector nozzles can be installed at different levels in the furnace, commonly in the first pass.

In principle, SNCR can be applied where a temperature window is available in the range of 850–1 050 °C. In most waste incineration plants, this window occurs in the upper part of the furnace.

SNCR systems perform best under steady operating conditions (equal ammonia distribution and NO_x concentration). When operating conditions are not steady, ammonia slip (excessive ammonia emission), inadequate NO_x treatment, or N₂O formation can occur.

Cross-media effects

Consumption levels associated with SNCR are identified in the table below.

Table 4.33: Consumption levels associated with the use of SNCR

Criteria	Units	Range of achieved values	Comments
Energy requirements	kWh/t waste input	45–50 thermal	Cooling effect of in-furnace injection
Reagent consumption	kg/t waste input	1–4	Ammonia, urea or ammonia water
Reagent stoichiometry	Ratio	2–3	

Source: [60, Reimann 2002]

For this technique, the most significant cross-media aspects are:

- energy consumption (lower than with SCR);
- possible production of N₂O (high global warming potential) and ammonia slip if the SNCR process is not well controlled;
- consumption of reagent (higher than with SCR);
- ammonia slip can contaminate residues and waste water; recovery of ammonia is possible.

In hydrated lime-based semi-dry, intermediate and dry FGC systems, the NH₃ slip is absorbed by the CaCl₂ formed by the removal of HCl. If this residue is subsequently exposed to water, the NH₃ will be liberated. This can have consequences for downstream residue treatment or cement stabilisation.

An ammonia stripper may be needed with wet systems to comply with local effluent discharge standards or in order to ensure adequate precipitation, e.g. of cadmium and nickel, from the process waste water. The addition of such a process adds operational complexity and cost.

Technical considerations relevant to applicability

The technique is generally applicable.

Higher dose rates may be used (hence resulting in lower NO_x emissions) while keeping ammonia slip levels low with downstream wet scrubbing. In such cases, an ammonia stripper may be required to reduce NH₃ levels in the effluent and reutilise the stripped NH₃ in the SNCR.

The normal maximum reduction efficiency of the technique is approximately 75 %. It is therefore not common for SNCR to be used where higher percentage reductions are required; typically this may align with NO_x emission levels below 100 mg/Nm³ (daily average). The higher reagent dose rates required to achieve reduction rates above 75 % means that achieving ammonia slip of < 10 mg/Nm³ may require the use of additional measures such as downstream wet scrubbing, and then techniques to control ammonia levels in the effluent may also be required, e.g. stripping. [74, TWG 2004]

Economics

The key aspects of this technique are:

- capital costs are significantly lower than with SCR;
- if an ammonia stripper is added the capital costs are still 10–30 % lower than with SCR;
- reagent consumption costs are higher than with SCR;
- operating costs are lower than with SCR, mainly due to the reduced energy requirements for flue-gas reheating.

Investment costs for SNCR for a two-line 200 000 t/yr MSWI are estimated as EUR 1 million. This compares with around EUR 4 million for SCR. [12, Achternbosch 2002]

Driving force for implementation

- Compliance with legislative NO_x emission requirements.
- Cost advantage compared with SCR.
- Lack of space for SCR.

If a discharge of ammonia-rich effluent is permissible, the use of this technique with a wet FGC system will be more economical as there will be no requirement for an ammonia stripper. This does not apply to other FGC systems that do not produce effluents.

Example plants

Widely applied throughout Europe.

Laanila WtE Plant-Oulu (FI) (FI4-1), Westenergy Oy Ab-Mustasaari (FI) (FI6-1), and Gärstadverket-Linköping (SE) (SE3) are example plants using advanced SNCR with acoustic or IR temperature profile measurement systems.

Reference literature

[1, UBA 2001], [2, InfoMil 2002], [3, Austria 2002], [12, Achternbosch 2002], [60, Reimann 2002], [64, TWG 2003]

4.5.4.4 Selective catalytic reduction (SCR)

Description

This technique is described in Section 2.5.5.

Technical description

The most common SCR reactions, which are catalysed, are:

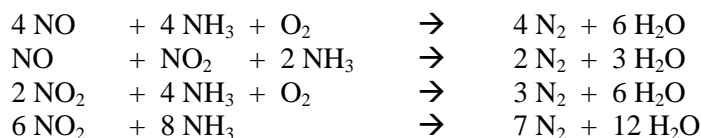

In waste incineration, SCR is generally applied after dedusting and acid gas cleaning (examples of the high dust/dirty gas use of this technique are rare). This being the case, flue-gases usually require reheating after the earlier FGC stages (usually the FGC exit temperature is 70 °C for wet systems and 120–180 °C for most bag filters) to reach the operational temperature for the SCR system (see below). The location of the SCR directly after a hot dedusting system is not common but is used at some plants across Europe and can avoid the disadvantages of any reheating of the flue-gases along the whole FGC line. [74, TWG 2004]

Operational temperature ranges for SCR systems are reported [64, TWG 2003] to range from 150 °C to 320 °C. However, it is most common for systems to operate in the range 180 °C to 240 °C. The lowest operational temperatures generally require cleaner flue-gases at the SCR inlet. The SO₂ concentration in the flue-gases may be critical and can result in poisoning of the catalyst. The catalyst material generally consists of the carrier (TiO₂) with added active substances (V₂O₅ and WO₃).

Achieved environmental benefits

The application of SCR generally results in lower NO_x emissions than other techniques. The main disadvantages are its higher capital cost, and the consumption of energy (usually natural gas, light oil or high-pressure steam) that is required to support the reheating of flue-gases to the catalyst reaction temperature. The selection of systems that operate effectively at the lower end of this temperature range and the use of heat exchange reduces the additional energy requirement.

Environmental performance and operational data

Emission reductions and the levels of emissions to air generally achieved by plants fitted with SCR are as follows.

Table 4.34: Emission levels associated with the use of SCR

Substance	Achieved emission ranges			
	Yearly maximum of		Annual average (mg/Nm ³)	Specific emission (g/t waste input)
	Half-hourly averages (mg/Nm ³)	Daily averages (mg/Nm ³)		
NO _x	50–200	40–150	40–120	220–660
NH ₃	3–30	3–10	< 3	< 17

Source: [81, TWG 2016]

In addition, if specifically designed (extra catalyst layer, higher operating temperature), SCR can also catalytically destroy PCDD/F (see Section 4.5.5.3). Destruction efficiencies of 98–99.9 % are seen, giving PCDD/F emissions in the range of 0.05–0.002 ng/Nm³ TEQ.

Table 4.35: Operational data associated with the use of SCR

Criteria	Description of factors affecting criteria	Evaluation (high/medium/low) or data	Comments
Complexity	<ul style="list-style-type: none"> Additional process units required Critical operational aspects 	H	
Flexibility	<ul style="list-style-type: none"> Ability of technique to operate under a range of input conditions 	H	High reduction rates generally achieved. Sensitive to SO ₂ , SO ₃ and P inlet concentrations. Multifunctional NO _x and PCDD/F reduction.
Skill requirements	<ul style="list-style-type: none"> Notable extra training or manning requirements 	H/M	

The temperature of the catalyst has an important effect on the (relative speed of) reactions. The optimum temperature range for catalytic reduction depends upon the type of catalyst used, but is commonly between 180 °C and 240 °C. [7, TWG 2017]

Generally, a lower operational catalyst temperature results in a slower reaction rate (NO reduction rates are slowed relatively more by lower temperatures than NO₂ rates) and possible ammonia slippage. A higher temperature results in a shortened catalyst lifetime and can lead to the oxidation of NH₃ and the production of additional NO_x [2, InfoMil 2002].

Lower temperature SCR systems are generally less effective for PCDD/F destruction and additional catalyst layers may be required. Lower temperature systems generally require cleaner inlet flue-gases – with low SO₂ values in particular. [64, TWG 2003]

Low operating temperature SCR requires an automatic cleaning device (e.g. soot blower).

Regular regeneration is required to remove ammonia salts. The frequency of regeneration with lower temperature systems may be as high as every 1 000 hours. At such a frequency this may become operationally critical as it could lead to NH₃ and SO₂ emission peaks if the flue-gas is not recirculated (see Section 4.3.6). The regeneration frequency can be greatly reduced by keeping low levels of SO_x at the catalyst entrance [74, TWG 2004], [7, TWG 2017]

The achieved environmental benefits may depend on the positioning in the overall FGC system. Where the SCR is before the scrubber, the NO_x reduction efficiency may be reduced, leading to emission values for NO_x above those presented in Table 4.26. [74, TWG 2004]

Catalysts:

[2, InfoMil 2002] Criteria for determining the type of catalyst to be used are:

- flue-gas temperature;
- NO_x reduction required;
- permissible ammonia slip;
- permissible oxidation of sulphur dioxide;
- concentration of pollutants;
- lifetime of the catalyst;
- requirement for additional gaseous PCDD/F destruction;
- dust concentration in the flue-gas.

[74, TWG 2004]

The following types of degradation limit the lifetime of catalysts:

- poisoning: where the active site of the catalyst is blocked by a strongly bound compound;
- deposition: where pores are blocked by small particles or condensed salts, such as ammonium bisulphate (NH₄HSO₄) – this can be reduced by SO_x reduction at the inlet and may be partially reversible by reheating the catalyst;
- sintering: where at excessively high temperatures the microstructure of the catalyst is destroyed;
- erosion: due to physical damage caused by solids and particles.

Typical catalyst lifetimes of 3 to 5 years are reported, although longer lifetimes, even exceeding 10 years, have been shown in some cases.

Droplets at the outlet of the scrubbing system which cause salt deposition are considered a critical factor that increases the catalyst degradation rate.

Note: The *catalyst lifetime* is the number of hours until the catalyst can no longer provide the required NO_x reduction without exceeding an agreed maximum NH₃ slip.

Cross-media effects

For this technique, the most significant cross-media effect is the energy requirement for flue-gas heating. This can be minimised with a low operating temperature of the catalyst. However, in such cases, catalyst regeneration (this is usually on site) then requires additional energy to regenerate the catalyst by sublimation of the salts deposited. [74, TWG 2004]

The energy demand (and cost) for reheating is generally greatly reduced by the use of a heat exchanger that uses the heat from the SCR exhaust to heat the SCR inlet. Energy losses, and hence additional demand, are then reduced to heat exchange and radiant losses. In cases where a demand exists for medium hot water, further economies may be made by installing an additional heat exchanger for the recovery of the SCR outlet energy for supply. Such a system has been used at SYSAV, Malmö, Sweden. [64, TWG 2003]

The two diagrams below show the application of SCR downstream of non-wet (i.e. dry or semi-dry) FGC and wet FGC systems. The temperature profiles are given. It can be seen that the second system (with the wet FGC) in this case includes an additional heat exchange step. Such a set-up reduces the requirement for additional energy input, but results in a colder final flue-gas discharge. Colder final stack discharge may require special measures to prevent stack corrosion and is likely to increase plume visibility.

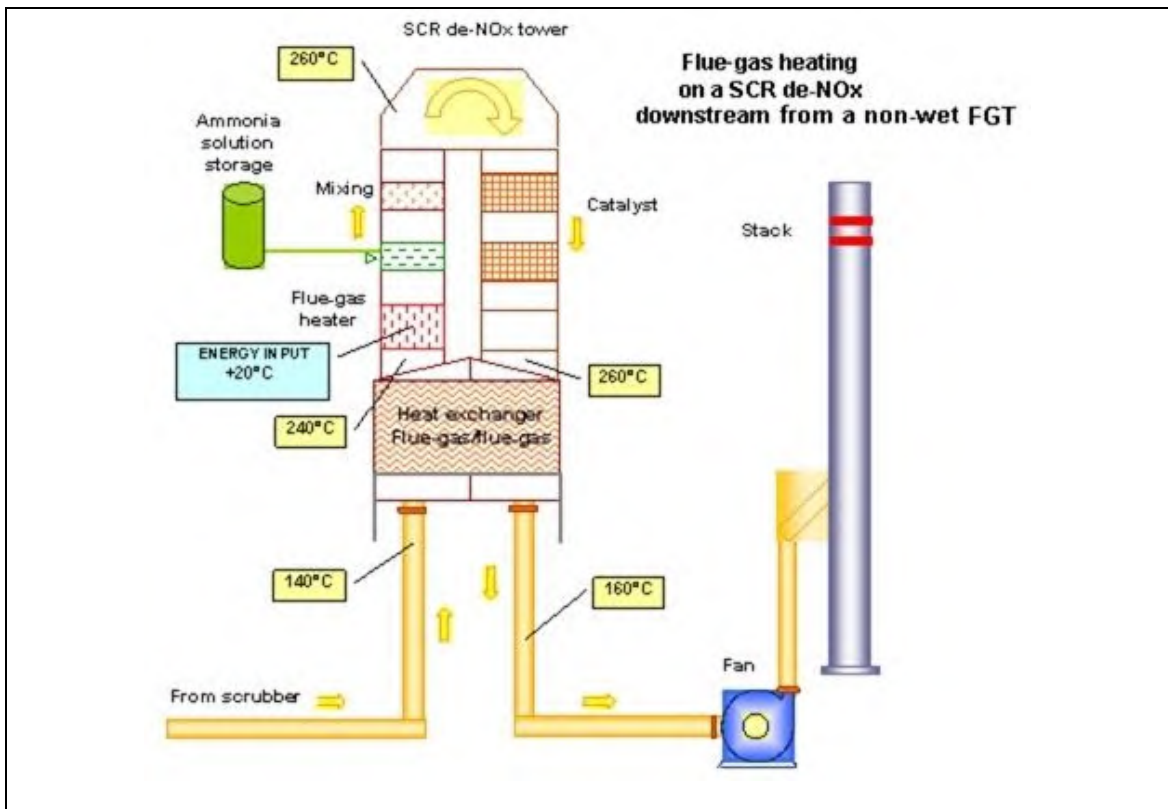

Figure 4.7: Diagram of a SCR system downstream of a non-wet FGC system showing typical heat exchange and temperature profiles

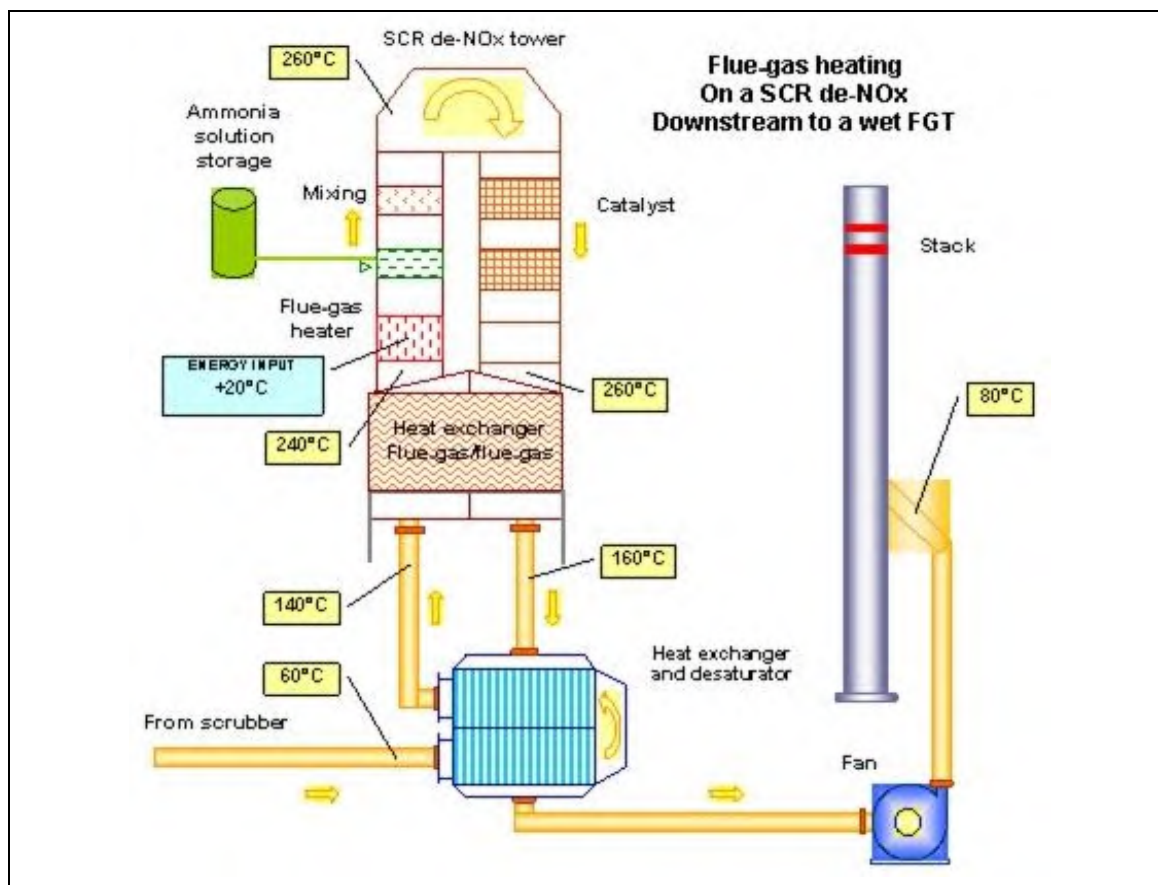

Figure 4.8: Diagram of a SCR system downstream of a wet FGC system showing additional heat exchange and temperature profiles

At equal NO_x reduction levels, reagent (usually ammonia solution) consumption rates are lower with SCR than with SNCR because of the lower level of unreacted ammonia (ammonia slip).

Cross-media effects are identified in the table below.

Table 4.36: Cross-media effects associated with the use of SCR

Criteria	Units	Range of values	Comments
Energy requirements	kWh/t waste input	65–100 thermal for high-temperature SCR, down to 3–5 for low-temperature SCR 10–15 electrical	Thermal relates to reheating, electrical to the additional pressure drop across the catalyst
Reagent consumption	kg/t waste input	1–3	25 % ammonia solution
Reagent stoichiometry	Ratio	1–1.1	Figure relates to input pollutant concentration
Residue – type			Spent catalyst when changed
Residue – amount	kg/t waste input	0.01	
Water consumption	l/t waste input		Not significant
Plume visibility impact	+/-	-	Reduced due to reheating applied with SCR

NB: The data in this table aim to provide the typical operational range. The precise amounts of residues and effluents produced will depend on many factors including raw gas concentrations (waste-related), flow rates, reagent concentrations, etc.

Source: [1, UBA 2001], [2, InfoMil 2002], [13, JRC(IoE) 2001], [60, Reimann 2002], [74, TWG 2004], [81, TWG 2016]

Technical considerations relevant to applicability

The technique is generally applicable as long as sufficient space is available (which may be a constraining factor for existing plants).

The SCR process unit is usually installed at the tail-end position because the flue-gas usually needs to be pre-dedusted and may also require the removal of SO₂/SO₃, and sometimes of HCl. Meeting the minimum inlet temperature needed for SCR may thus require reheating of the flue-gas.

Economics

Investment costs for SCR for a two-line 200 000 t/yr MSWI were estimated at EUR 4 million. This compares with around EUR 1 million for SNCR. [12, Achternbosch 2002].

Another de-NO_x study reported a capital cost for a SCR unit for a 100 000 t/yr plant in the range of EUR 7.5 million to EUR 9.5 million. [74, TWG 2004]

Operating costs are in general 25–40 % lower for SNCR than for SCR (depending on reagent for SNCR, temperature for SCR, preheating, etc.). [13, JRC(IoE) 2001], [74, TWG 2004]

Large plants with higher gas flow rates and economies of scale are more able to support the additional cost burden of SCR.

High-pressure steam can be used for the SCR reheating, which entails an economic impact proportional to the price that can be charged for exported energy (either as heat or when converted into electricity).

Driving force for implementation

- Reaching NO_x levels below 100 mg/Nm³.
- NO_x taxes set at a level that makes the technique economically favourable.
- Availability of high-pressure steam for the flue-gas reheating (this reduces operational costs when low revenues are received for the energy produced).

Example plants

SCR is widely used in the incineration industry. There are examples in Germany, Austria, the Netherlands, Belgium, France, Japan and elsewhere.

Around 150 of approximately 350 incineration lines operating in the installations that participated in the 2016 data collection use SCR. They include non-hazardous incineration plants as well as merchant and industrial HWIs.

Reference literature

[1, UBA 2001], [2, InfoMil 2002], [13, JRC(IoE) 2001], [60, Reimann 2002], [61, SYSAV 2002], [64, TWG 2003]

4.5.4.5 SCR by catalytic filter bags**Description**

This technique is described in Section 2.5.8.3. De-NO_x catalytic filters are filter bags which are installed in a bag filter for the reduction of dust, but also have a catalyst layer that performs the SCR function.

Technical description

The technique can be implemented as slip catalyst in combination with SNCR, with an additional NH₃ injection step immediately before the bag filter.

Achieved environmental benefits

For WI plants equipped with a bag filter but not with SCR, the replacement of filter bags with de-NO_x catalytic bags can reduce NO_x emissions to those characteristic of SCR at a low investment cost, and with minimal change to the existing plant configuration. NO_x emission levels in the 50–75 mg/Nm³ range are reported.

Environmental performance and operational data

The following levels have been reported for plants retrofitted with this technique.

Table 4.37: Emission levels associated with the use of SCR by catalytic filter bags

	Prior to retrofit	With catalytic filter bags
NO _x (daily average, 11 % O ₂)	135–200 mg/Nm ³	50–120 mg/Nm ³
NH ₃ (daily average, 11 % O ₂)	1–10 mg/Nm ³	1–5 mg/Nm ³

The operating temperature is between 190 °C and 210 °C with PTFE-based filter bags, and may be extended to up to 260 °C with fibreglass-based filter bags.

Compared with a SNCR system, operational consequences associated with this technique may include:

- some increase of ammonia water or urea solution consumption for the further reduction of NO_x emissions;
- a potential increase in alkaline reagent consumption to ensure SO₂ levels below 5 mg/ Nm³ as required by the technique (similar to other tail-end SCR systems).

Cross-media effects

No major cross-media effects are reported.

NH₃ slip is reduced compared to the SNCR technique.

The energy consumption from the pressure drop across the filter is similar to conventional bag filters.

Technical considerations relevant to applicability

The technique is applicable to new plants and to existing plants fitted with a bag filter, with or without pre-existing SNCR.

Economics

The total investment cost to install the technique on an existing line was reported as EUR 273 000 for plant modification and EUR 416 000 for the special filter bags.

Driving force for implementation

- Reaching NO_x emissions below 100 mg/ Nm³ while keeping low levels of NH₃ slip.
- Lack of space for SCR.
- Reduced investment costs compared with a conventional SCR unit.

Example plants

Acegas in Padua (IT) (IT18), since September 2011; CEDLM Limoges (FR) (FR052), since January 2014; Villefranche (FR), since September 2013.

Reference literature

[102, CEFIC 2015]

4.5.5 Techniques to reduce organic compounds including PCDD/F and PCB emissions

4.5.5.1 Primary techniques for prevention or reduction of organic compounds including PCDD/F and PCBs

A well-controlled combustion process, preventing the formation of precursors, is key for the prevention of PCDD/F formation in waste incinerators. The techniques that are applicable for improving the combustion-related aspects that will lead to generally improved incineration performance, including a reduction in the risk of PCDD/F production, are addressed in the following sections of this document:

Operational techniques to improve environmental performance

Techniques for the control and preparation of the waste before it is incinerated result in improved combustion characteristics and knowledge of the waste, allowing for better combustion control and, hence, a reduced risk of PCDD/F formation.

Thermal processing

Well-controlled combustion aids the destruction of PCDD/F and its precursors which may already be in the waste and prevents the formation of precursors.

Techniques to increase energy recovery

In the energy recovery zones of the incineration installation, the most important concern from a PCDD/F perspective is the prevention of reformation. The presence of precursor substances and detailed design in the temperature zones that may increase the risk of PCDD/F formation are of particular importance. The descriptions of techniques to increase energy recovery include consideration of the PCDD/F aspects.

4.5.5.2 Prevention of reformation of PCDD/F in the FGC system

Description

Reducing the residence time of dust-laden gas in the 450 °C to 200 °C temperature zone reduces the risk of formation of PCDD/F and similar compounds.

Technical description

If dust removal stages are used in this temperature range the residence time of the fly ash in this range is prolonged, increasing the risk of PCDD/F formation. Dust removal devices in the high dust zones (commonly electrostatic precipitators and some bag filters) operated at temperatures above 200 °C increase the risk of PCDD/F formation. Temperatures at the inlet to the dust removal stage should, therefore, be controlled to below 200 °C. This can be achieved by:

- additional cooling in the boiler (the boiler design in the 450–200 °C range should itself limit dust residence to avoid simply transferring the problem upstream);
- addition of a spray tower to reduce the temperature at the boiler exit to below 200 °C for the subsequent dust cleaning stages;
- full quench from combustion temperatures to approximately 70 °C - this is carried out at plants where there is no boiler cooling and usually only where there is an increased dioxin risk owing to the nature of the waste incinerated (e.g. high PCB inputs); quenching down to 70 °C is common in HWIs operated by the chemical industry;
- gas-gas heat exchange may also be implemented (gas from inlet scrubber - gas from outlet scrubber).

[74, TWG 2004]

De novo synthesis may potentially also cause high PCDD/F emission loads during cold start-ups. This may be minimised by avoiding the use of a bypass upstream of the bag filter at start-up. The preheating of the bag filter before start-up, or the preheating of the flue-gas at start-up are techniques to prevent the low-temperature clogging of the bag filter.

Achieved environmental benefits

The risk of PCDD/F production in the process and, hence, subsequent emissions are reduced.

Where solid wastes and flue-gas already go for subsequent treatment that effectively destroys the dioxins produced (e.g. SCR for gas, plus heat treatment for fly ash), the benefit achievable by adopting the technique is reduced.

Environmental performance and operational data

Quench systems employed at some HWIs are reported to effectively eliminate PCDD/F formation. [46, Cleanaway 2002]

Where heat recovery boilers are used, but dust removal is avoided in the 450–200 °C range, raw gas concentrations in the range of 1–30 ng TEQ/Nm³ are seen before dioxin removal/destruction. Where dust removal is carried out in the 450–200 °C range, downstream gas can contain from 10 ng TEQ/Nm³ to > 100 ng TEQ/Nm³ PCDD/F.

Cross-media effects

Existing plants with high-temperature dust removal stages may utilise such systems in order to retain heat in the flue-gases so that this heat can subsequently be used for some other purpose, e.g. transfer by heat exchange to later flue-gas treatment systems. If the gases are cooled to below 200 °C, this may lead to a need for additional heat input to the flue-gas to maintain the required temperature profile for those downstream systems. It may be possible for losses to be reduced by, instead, using the heat removed prior to the dust removal stage for reheating using heat-exchange systems.

Full quench systems generally result in limited opportunities for energy recovery (boilers are not usually found where full quench is employed). They also create a very moist plume that increases visibility and condensation, and require large water injection rates to provide sufficient cooling of the hot flue-gases. The waste water produced may be recirculated to some degree, but discharge and water treatment are usually required. Recirculated water may require cooling to prevent losses to the stack and to maintain FGC operation.

Technical considerations relevant to applicability

The technique is generally applicable to new plants.

Retrofitting existing plants will require a detailed reappraisal of the flue-gas treatment process, with particular attention paid to heat distribution and use.

Economics

There are no significant cost implications for new processes.

Very significant capital investments may be required at some existing processes for the replacement of boiler and flue-gas treatment systems. Investments in the order of EUR 10–20 million may be required for such changes.

Operational cost reductions may be seen from:

- sales of additional energy (heat) recovered in boilers;
- where adsorption is used, reduced cost of disposal of solid residues due to their lower PCDD/F contamination;
- reduced dioxin content may have a positive impact on FGC downstream: lower activated carbon rate and/or lower catalyst volume.

[74, TWG 2004]

Driving force for implementation

- Concerns regarding the possible production of PCDD/F by the process.
- Concerns regarding the PCDD/F concentrations in FGC absorbents requiring disposal.
- Waste types with a high risk of PCDD/F formation.

Example plants

Quench systems are widely used in Europe, e.g. Belgium, Germany, France, the Netherlands, Norway, Sweden and the UK.

Low boiler exit temperatures and post-boiler gas cooling is widely used in Europe.

Reference literature

[46, Cleanaway 2002], [64, TWG 2003], [74, TWG 2004]

4.5.5.3 Destruction of PCDD/F using SCR**Description**

PCDD/F destruction by catalytic oxidation over the SCR catalyst.

Technical description

While SCR systems are primarily used for NO_x reduction (see description in Sections 2.5.5.2.2 and 4.5.4.1), if large enough they can also destroy gas-phase PCDD/F through catalytic oxidation. Typically two to three SCR catalyst layers are required to provide combined NO_x and PCDD/F reduction.

It is important to note that in waste incineration the majority of airborne PCDD/F is adhered to dust, with the rest being the gas-phase PCDD/F. Techniques that remove dust will, therefore, remove the dustborne PCDD/F, whereas SCR (and other catalytic methods) only destroy the smaller proportion in the gas phase. A combination of dust removal plus destruction generally gives the lowest overall emissions of PCDD/F to air.

Achieved environmental benefits

Where these FG polishing residues would normally be sent off site, this results in an overall reduction in the dioxin outputs to all media from the installation. Where the dioxin residues are collected separately (e.g. using carbon) from other FGC residues and reburned, if allowed, in the installation then the reduction in overall outputs that may be gained by using SCR as an additional destruction method is less significant.

NO_x is treated by SCR at the same time as PCDD/F to give very low NO_x releases (see Section 4.5.4.1).

In the few cases where SCR is applied before other FGC components, it must be noted that the non-gas-phase (dust-bound) PCDD/F may not be treated in the SCR unit and may therefore require subsequent dust removal to reduce it.

Environmental performance and operational data

Operational data are given in Section 4.5.4.1.

Destruction efficiencies for gas-phase PCDD/F of 98 % to 99.9 % are seen, giving PCDD/F emissions (in combination with other FGC techniques) often in the range of 0.005–0.05 ng/Nm³ TEQ.

In general, SCR is applied after initial dedusting. The dust that is removed at the pre-dedusting stage will carry with it the adsorbed PCDD/F (this may be the majority). The residues from the pre-dedusting stage will, therefore, be contaminated with PCDD/F to the same degree whether SCR is applied or not. SCR, therefore, reduces PCDD/F contamination of FGC residues only where further downstream dust polishing is also applied.

Because it is normal for the majority of PCDD/F to be associated with dust, for overall PCDD/F reduction, it is usually important that dust removal techniques are applied as well as SCR. This is to ensure that dust-bound PCDD/F, which would not be destroyed in the SCR unit, is removed from the flue-gases.

While a single catalyst layer may have a dramatic impact on NO_x, a greater size is required to ensure effective PCDD/F destruction as well. The higher the number of layers of catalyst, the greater the impact will be on PCDD/F reduction.

Cross-media effects

Cross-media effects are detailed in Section 4.5.4.1.

The most significant cross-media aspects are:

- consumption of energy for flue-gas reheating to reach the SCR system reaction temperature;
- as a destruction technique, the PCDD/F are not transferred to solid residues (as with some adsorption processes).

In general, destruction is preferable to transfer to another media. However, the magnitude of the benefit associated with the destruction rather than adsorption of PCDD/F will depend on the avoided risk that is associated with the subsequent downstream management of the PCDD/F-laden residues.

Technical considerations relevant to applicability

The applicability of this technique is assessed in Section 4.5.4.1.

Economics

The costs of the technique are shown in Section 4.5.4.1.

Driving force for implementation

The implementation of this technique is favoured where the combination of high NO_x reduction and the additional PCDD/F reduction given by SCR is required.

Example plants

SCR is widely used in the incineration industry. There are examples in Austria, Belgium, Germany, France, the Netherlands, Japan and elsewhere.

SCR is also applied to merchant HWIs, particularly in Germany, at ES11 and PL03.

Reference literature

[1, UBA 2001], [2, InfoMil 2002], [3, Austria 2002], [13, JRC(IoE) 2001], [27, Belgium 2002], [61, SYSAV 2002], [64, TWG 2003]

4.5.5.4 Destruction of PCDD/F using catalytic filter bags

Description

This technique is described in Section 2.5.8.3.

Technical description

See Section 2.5.8.3.

Achieved environmental benefits

Destruction efficiencies of PCDD/F entering the catalytic filter bags of above 99 % are reported at a MSWI. Emission concentrations of PCDD/F of below 0.02 ng/Nm³ TEQ resulted from inlet concentrations of 1.9 ng/Nm³. [27, Belgium 2002]

The filters also remove dust. In the example given here, the MSWI used an ESP for pre-dedusting and with the addition of the filters gave dust emission levels in the range of 0.2–0.6 mg/Nm³. NO_x reduction is also reported using these filters. [64, TWG 2003]

The total release of dioxins from the installation (to all media) is also reported to be reduced by destruction, rather than adsorption (with activated carbon). At the same time as reducing emissions to air as described above, samples of bag filter hopper dust showed average concentrations dropped from 3 659 ng I-TEQ/kg of dust (when using activated carbon) to 283 ng I-TEQ/kg of dust (using catalytic filter bags).

Environmental performance and operational data

Operational matters are similar to those of other bag filters.

The temperature range necessary for the catalytic reaction to occur is between 180 °C and 260 °C. [27, Belgium 2002], [74, TWG 2004]

Tests carried out over 21 months on inlet and outlet PCDD/F concentrations at a MSWI (without upstream acid gas removal, but with a pre-dedusting ESP) showed the following results.

Table 4.38: Destruction efficiency data for catalytic filter bags over 21 months of operation

Number of months of operation	0.25	1.5	3	4.8	8	13	18	21
Inlet PCDD/F (ng TEQ/Nm ³)	3.4	7	11	10.5	11.9	11.8	8.1	5.9
Outlet PCDD/F (ng TEQ/Nm ³)	0.01	0.0035	0.005	0.004	0.01	0.011	0.002	0.023
Calculated efficiency	99.7 %	99.9 %	99.9 %	99.9 %	99.9 %	99.9 %	99.9 %	99.6 %
<i>Source: [27, Belgium 2002]</i>								

The catalytic media do not treat mercury so an additional technique is required such as injection of active carbon or similar.

Cross-media effects

The most significant cross-media effect associated with catalytic filter bags is the energy consumption from the pressure drop, but this is similar to any bag filter.

Catalytic filter bags are generally used as a replacement for other filter bags. These may already adsorb dioxins by the injection of activated carbon. Where, in the replaced system, it is the injection of activated carbon that also provides for the main absorption of metallic mercury, the removal of the activated carbon may then result in an increase in mercury emissions to air unless alternative techniques for mercury are used.

Technical considerations relevant to applicability

The technique is generally applicable to new plants and to existing plants fitted with a bag filter.

Economics

For a MSWI of two lines with a capacity of 27 500 t/yr each, the additional cost of the use of catalytic filter bags was reported as between EUR 2 and EUR 3 per tonne of waste treated. [27, Belgium 2002]

The key cost aspects of this technique are:

- increased investment cost of the bags compared with non-catalytic bags;
- lower investment costs than SCR but with similar destruction efficiencies;
- the need to make additional provision for mercury removal.

[74, TWG 2004]

Driving force for implementation

- Reduction of PCDD/F emissions to well below 0.1 ng/ Nm³ TEQ.
- Lack of space for SCR.

Example plants

Several installations in Belgium and France.

Reference literature

[27, Belgium 2002], [64, TWG 2003]

4.5.5.5 Adsorption of PCDD/F by injection of activated carbon or of other adsorbents

Description

This technique is described in Section 2.5.8.1.

Technical description

In summary, activated carbon is injected into the gas stream where it mixes with flue-gases. Activated carbon is injected on its own or is combined with an alkaline reagent such as (usually) hydrated lime or sodium bicarbonate. The injected alkaline reagent, their reaction products and the carbon adsorbent are then collected in a deduster, usually a bag filter. The adsorption of the PCDD/F occurs in the gas stream and on the reagent layer formed when barrier filters are used (e.g. filter bags).

The adsorbed PCDD/F are discharged with other solid wastes from the bag filter, ESP or other dust collection apparatus used downstream.

It is reported that mineral adsorbents (e.g. mordenite, zeolite, mixtures of clay minerals, phyllosilicate and dolomite) may also be used for PCDD/F adsorption, at temperatures of up to 260 °C without risk of fire in the baghouse. Lignite coke is also reported to be used. [64, TWG 2003] [74, TWG 2004]

The effect of catalytic destruction of PCDD/F on the surface of the activated coke has been reported [74, TWG 2004].

Achieved environmental benefits

The benefit is the reduction of PCDD/F emissions.
Metallic mercury is also adsorbed (see Section 4.5.6.2).

Environmental performance and operational data

Carbon consumption rates of 0.5–3 kg/t of waste are reported as typical for MSWIs. Higher injection rates may provide additional reductions in PCDD/F. [64, TWG 2003]

Usually the dose rate of activated carbon is between 0.5 kg/t and 2 kg/t to achieve an emission level below 0.06 ng I-TEQ/Nm³.

Different types of carbon have different adsorption efficiencies.

Cross-media effects

The cross-media effects of the use of bag filters or other dust abatement systems associated with the use of this technique are described in Section 4.5.2.

Solid residue containing the adsorbed pollutants is produced.

Technical considerations relevant to applicability

The technique is generally applicable and is most often used in combination with a bag filter.

Economics

Lignite coke is reported to be more economical than activated carbon. [64, TWG 2003] It is also reported that, in general, the consumption of lignite coke is higher than that of activated carbon (up to double the ratio). [74, TWG 2004]

Driving force for implementation

The driving force is compliance with legislative requirements for PCDD/F emission levels.

Example plants

Widely applied technique in many countries.

Reference literature

[64, TWG 2003]

4.5.5.6 Fixed-bed adsorption of PCDD/F**Description**

This technique is described in Section 2.5.8.6.

Technical description

Wet and dry fixed coke/coal beds are used. Wet systems include countercurrent washing with water.

Achieved environmental benefits

Benefits include the reduction of emissions to air of PCDD/F and of mercury with a high level of efficiency. The technique, where the adsorption capacity of the bed is sufficiently high, is also able to effectively prevent the occurrence of emission peaks.

Environmental performance and operational data

PCDD/F are adsorbed to give clean gas emissions below 0.03 ng I-TEQ/Nm³.

The temperature at the inlet to a dry fixed coke bed is typically 80–150 °C, and 60–70 °C in the case of wet fixed beds. If followed by a SCR system, the reheat required would therefore be greater for a wet system.

With dry systems, particular care is required to ensure that the flue-gas is evenly distributed as this reduces the risk of fire. The temperature across the bed requires close monitoring and control to reduce the fire risk, e.g. several CO measurements over the whole filter body to measure hot spots. [74, TWG 2004] The use of inert gases may be required.

Wet fixed beds have a significantly lower fire risk. Neither firefighting nor inert blanketing is required. The addition of a partially recirculated water feed also provides a means for removal of the accumulated dust, which can lead to bed clogging.

The bed saturation rate is assessed to determine the required reagent replenishment rate. [74, TWG 2004]

The lack of moving parts ensures high reliability.

A summary evaluation of the operational implications associated with the use of fixed-bed adsorption is presented in Table 4.39.

Table 4.39: Operational data associated with the use of the fixed-bed adsorption static coke filters

Criterion	Description of factors affecting the criterion	Evaluation (high/medium/low)	Comments
Complexity	<ul style="list-style-type: none"> Additional process units required Critical operational aspects 	M	<ul style="list-style-type: none"> Fire risks require careful control (dry systems)
Flexibility	<ul style="list-style-type: none"> Ability of technique to operate under a range of input conditions 	H	<ul style="list-style-type: none"> Very high adsorption capacity
Skill requirements	<ul style="list-style-type: none"> Significant extra training or manning requirements 	H/M	<ul style="list-style-type: none"> Robust, but care required regarding fire risk (dry systems) and if reburning carried out

Cross-media effects

Cross-media effects are identified in the table below.

Table 4.40: Cross-media effects associated with the use of the fixed-bed adsorption static filters

Criteria	Units	Value	Comments
Energy requirements	kWh/t waste input	30–35	Pressure drop across filter
Reagent consumption	kg/t waste input	1	Coke
Residue	kg/t waste input	0–1	Zero if coke can be burned in the incinerator
Plume visibility	+0/-	+0	Wet system will add to plume visibility
<i>Source: [12, Achternbosch 2002]</i>			

For this technique, the most significant cross-media effect is the energy required to overcome the filter pressure drop.

For one rotary kiln HWI line treating 50 000 t/yr, together with the installation of a fixed-bed filter, a new 550 kW ID fan was installed to replace a 355 kW fan (ΔP of the fixed bed of between 25 mbar and 40 mbar) [64, TWG 2003].

The fire risk might be increased with dry fixed beds depending on the design of the whole FGC line [74, TWG 2004].

When saturated, the used activated carbon is often landfilled as a toxic residue. If permitted, it can be reburnt in the incinerator to destroy the adsorbed PCDD/F. As the carbon adsorber will adsorb mercury as well as PCDD/F, if the spent coke is to be reburned, mercury circulation requires careful consideration. The practice of reburning will result in an accumulation of mercury in the process unless there are additional techniques that provide a mercury outlet, e.g. low pH wet acid scrubbing.

[74, TWG 2004]

The following cross-media effects data were reported for the use of a wet fixed coke bed at a HWI treating around 11 000 tonnes of waste per year [64, TWG 2003]:

- use of lignite coke: 0.5 kg/t of waste input;
- exhausted lignite is burned in the installation – in this case, the accumulation of mercury is prevented by a low pH wet acid scrubbing system;
- water is used for periodically flushing the lignite bed; this generates acid waste water which is sent to an on-site physico-chemical treatment process;
- the wet system adds to flue-gas humidity and plume visibility.

Technical considerations relevant to applicability

The technique is generally applicable to new plants.

The availability of space for the additional process unit is required for the retrofit of existing plants.

Especially at plants already fitted with a bag filter, the cumulated pressure drop caused by the flue-gas cleaning system may be a constraining factor.

Economics

The investment cost of a fixed-bed coke filter for a 100 000 t/yr MSWI was estimated as EUR 1.2 million in 2002 [12, Achternbosch 2002].

The investments cost for one fixed-bed wet filter (empty) (incineration line of 50 000 t/yr) is approximately EUR 1 million (equipment and civil work).

The cost of lignite coke is a factor three to four times lower than activated coal.

The consumption of lignite cokes is low enough that refilling can be carried out during planned shutdowns.

Driving force for implementation

The driving force for implementation is compliance with legislation in relation to emission limits for PCDD/F and mercury, especially in the case of highly heterogeneous and hazardous wastes where PCDD/F may be high due to difficult combustion conditions.

Example plants

Hazardous waste incinerators in Austria, Belgium, Germany and the Netherlands.

Municipal waste incinerators in Austria and Germany.

Reference literature

[1, UBA 2001], [3, Austria 2002], [12, Achternbosch 2002], [64, TWG 2003]

4.5.5.7 Use of carbon-impregnated materials for PCDD/F adsorption in wet scrubbers

Description

The addition in the scrubber of tower packing containing plastics embedded with carbon sorbent.

Technical description

This technique is described in Section 2.5.8.5.

Achieved environmental benefits

PCDD/F are strongly adsorbed on the carbon particles in the material. Therefore the emissions are reduced and the memory-effect release of PCDD/F is prevented. [74, TWG 2004] Start-up releases may be reduced. The benefits can be summarised as:

- prevention of memory-effect in wet scrubbers and the associated risk of breakthrough and desorption releases;
- reduction of PCDD/F loads on subsequent FGC operations (especially during start-up);
- if the used reagent is returned in the furnace, there will be an overall reduction in the dioxin mass balance due to the destruction of the PCDD/F in the furnace (which is facilitated by the separation of the mercury absorption step) rather than their transfer to solid residues.

Environmental performance and operational data

With inlet concentrations of 1–5 ng TEQ/Nm³, gas-phase removal efficiencies in the range of 99–99.8 % are reported across a wet scrubber. Additional operational aspects are summarised in Table 4.41.

Table 4.41: Operational aspects data associated with the use of carbon-impregnated materials in wet scrubbers

Criteria	Description of factors affecting criteria	Evaluation (high/medium/low)	Comments
Complexity	<ul style="list-style-type: none"> • Additional process units required • Critical operational aspects 	L/M	Adjustment to existing technique (wet scrubbing)
Flexibility	<ul style="list-style-type: none"> • Ability of technique to operate under a range of input conditions 	M	
Skill requirements	<ul style="list-style-type: none"> • Notable extra training or manning requirements 	L	No significant additional requirements

When used as the main technique to reduce PCDD/F in combination with an electrostatic precipitator, the technique requires a more extensive tower packing installation. [74, TWG 2004]

Cross-media effects

The used packing is in some cases landfilled as a toxic residue. In some cases, it is returned in the incinerator (although local regulations sometimes do not permit reburning). [74, TWG 2004]

Technical considerations relevant to applicability

The technique is generally applicable to plants fitted with a wet scrubber. Implementation is straightforward in packed tower scrubbers.

The technique has also been demonstrated in dry and semi-wet (saturated gas) systems. [109, Sweden 2016]

Economics

The approximate investment cost for the initial installation of tower packing in two wet scrubber stages is between EUR 30 000 and EUR 150 000 in total for incineration plants of 5–20 t/h.

The cost for replacement material is estimated as EUR 0.1–0.2 per tonne of incinerated waste. No additional energy consumption is anticipated, except the additional pressure drop. [74, TWG 2004]

Driving force for implementation

- Reduction of dioxin build-up in the wet scrubber and of PCDD/F emissions at start-up especially where there is no subsequent FGC stage to control PCDD/F desorbed from the wet scrubber.
- As a pre-dioxin filter before a subsequent dioxin reduction system, to reduce the PCDD/F load on the main dioxin reduction system.

Example plants

The technique has been implemented at around 120 municipal and hazardous waste incineration plants worldwide, the majority in Europe.

Reference literature

[58, Andersson 2002], [64, TWG 2003]

4.5.5.8 Use of carbon slurries in wet scrubbers**Description**

The use of a slurry of activated carbon in a wet scrubber can both reduce the level of dioxin emissions to the flue-gas stream and prevent the accumulation of dioxins in the scrubber material ('memory effect').

Technical description

At a pH near neutral, activated carbon at a concentration varying between a few g/l to 50 g/l is added into the system, using a decanter to bleed the liquids, while retaining the carbon.

Because the activated carbon has active sites, the PCDD/F molecules are transferred to the liquids sprayed in the scrubber and the dioxins are subsequently adsorbed on the carbon, where a catalytic reaction takes place.

Achieved environmental benefits

In addition to the reduction of PCDD/F, the activated carbon also adsorbs mercury.

The activated carbon that is purged from the system is not contaminated by PCDD/F.

As activated carbon converts SO₂ to sulphuric acid, this process is also a polishing step for SO₂ removal.

The reported PCDD/F concentration in the waste water evacuated is below 0.1 ng TEQ/l. [74, TWG 2004]

Environmental performance and operational data

Emissions of PCDD/F at the stack are below 0.06 ng TEQ/Nm³.

Emissions of mercury are usually well below 50 µg/Nm³ for municipal waste incineration.

NaOH must be used to control the pH in the unit where the activated carbon slurry is used.

Cross-media effects

Use of carbon.

Technical considerations relevant to applicability

Applicable to wet scrubbers operated with caustic soda to control the pH at near neutral level.

Economics

Costs are limited to the reagent costs if used for polishing or to treat memory effect. Only minor modifications to the scrubbing system are required to allow the use of the technique.

For efficient PCDD/F removal this technique may require a specific packing tower scrubber, to ensure effective contact between the flue-gas and the washing water. [74, TWG 2004]

Driving force for implementation

The driving force for implementation is compliance with legislation in relation to emission limits for PCDD/F.

Example plants

Around 100 waste incineration plants are reported to be fitted with the technique.

Reference literature

[64, TWG 2003]

4.5.6 Techniques to reduce mercury emissions

4.5.6.1 Low pH wet scrubbing and additives injection

Description

The wet scrubbing technique is described in Section 2.5.4.

Technical description

[63, Langenkamp 1999] The use of wet scrubbers for acid gas removal causes the reduction of pH of the scrubber. Most wet scrubbers have at least two stages. The first removes mainly HCl, HF and some SO₂. A second stage, maintained at a pH of 6–8, serves to remove SO₂.

The mercury removal capacity can be increased with the use of additives in the scrubbing liquor, such as sulphur compounds, activated carbon and/or oxidants, to either bind mercury into the stable and insoluble species HgS or adsorb it to activated carbon.

The injection of additives may be automatically controlled by the signal of the mercury emission monitor or by a dedicated monitor for the mercury concentration in the raw flue-gas, thereby providing effective peak control capability. The use of a raw flue-gas monitor provides the additional advantage of peak detection with the shortest time lag, as once the mercury reaches the stack it will have exhausted the buffer capacity of the FGC equipment, possibly resulting in the contamination of certain components of it.

Achieved environmental benefits

The environmental benefit is the reduction of mercury emissions to air by transfer to the aqueous phase and subsequent capture at the waste water treatment stage.

Environmental performance and operational data

If the first stage of the wet scrubber is kept at a pH of below 1, the removal efficiency of ionic mercury as HgCl₂, which is generally the main compound of mercury after waste combustion, is over 95 %. However, the removal rates of metallic mercury are only in the order of 0–10 %, mainly as a result of condensation at the scrubber operating temperature of around 60–70 °C.

Metallic mercury adsorption can be improved up to a maximum of 20–30 % by the following:

- Addition of sulphur compounds to the scrubber liquor.
- Addition of activated carbon to the scrubber liquor.
- Addition of oxidants, e.g. hydrogen peroxide, to the scrubber liquor. This technique converts metallic mercury to the ionic form as HgCl₂ to facilitate its precipitation, and has the most significant effect. See also Section 4.5.6.5.

The overall mercury removal (both metallic and ionic) efficiency is around 85 %.

It is reported that a removal efficiency higher than 90 % can also be achieved by adding bromine-containing wastes or by injection of bromine-containing chemicals into the combustion chamber. [74, TWG 2004]

The concentration of mercury in the incinerated waste and the content of chloride are decisive in the determination of the final emission levels achieved.

In any case, the addition of further mercury abatement capacity may be required, depending on the inlet concentration, such as:

- carbon injection before a bag filter system;
- static coke bed filter.

(See Sections 4.5.6.2 and 4.5.6.7.) [74, TWG 2004]

The variation of mercury input to MSW can be very large and, therefore, can result in significant variations in emission levels. Values measured at an Austrian MWI gave values between 0.6 mg/kg and 4 mg/kg. This variation can be much greater in other waste types, e.g. some hazardous wastes.

The use of wet acid scrubbers for mercury emission reduction may be sufficient to achieve the required emission levels where:

- the pH is well controlled below 1;
- chloride concentrations are high enough for the crude flue-gas mercury content to be almost entirely ionic (and hence removable as chloride).

Where additives are added to the low pH scrubber, in the case of mercury input levels that are typically low but subject to occasional peaks, e.g. in municipal waste incineration, the additive dosage is kept low (e.g. 0.5–2 l/h), and raised in the case of mercury breakthrough (e.g. up to 10–20 l/h). Typical mercury emission reduction efficiencies between 90 % and more than 99 % are reported when using additives, allowing for outlet mercury concentrations below 30 µg/Nm³ as a short-term average. [111, Germany 2016]

Cross-media effects

Cross-media effects of the use of wet scrubbing are given in Section 4.5.3.1.

Consumption of any reagents added is also to be taken into consideration.

Technical considerations relevant to applicability

Where a wet scrubber is installed, the technique is generally applicable as a pre-treatment step to control mercury emissions to air in combination with other techniques, or applicable alone where input mercury concentrations in the waste are low enough (e.g. below 4 mg/kg). See Section 4.5.3.1 for the applicability of wet scrubbing systems.

Economics

No information provided.

Driving force for implementation

Reduction of mercury emissions.

Example plants

Several plants use wet scrubbing enhanced with additives, e.g. DE29 is an example of a plant using sulphides.

Reference literature

[1, UBA 2001], [2, InfoMil 2002], [3, Austria 2002], [12, Achternbosch 2002], [55, EIPPCB 2002], [63, Langenkamp 1999], [64, TWG 2003], [111, Germany 2016]

4.5.6.2 Activated carbon injection for mercury adsorption

Description

This technique involves the injection of activated carbon upstream of a bag filter (see also Section 4.5.5.5, bag filters are described in Section 2.5.3.5) or another dedusting device. Mercury is adsorbed in the stream and where barrier filters such as bag filters are used, and also on the reagent that is retained on the bag surface.

Technical description

Activated carbon acts as an adsorbent to capture mercury. At the typical temperatures of the flue-gas, the adsorption rate of elemental mercury onto untreated activated carbon is much lower than that of oxidised mercury. Techniques to oxidise elemental mercury are therefore used to enhance total mercury removal. Brominated activated carbon oxidises the elemental mercury to its ionic form which is then adsorbed onto the activated carbon. Ionic mercury is removed by chemical adsorption enhanced by the sulphur contained in the flue-gases or impregnated in some types of sulphur-doped activated carbon. [74, TWG 2004], [7, TWG 2017]

A further development of this technique involves the separate injection of highly effective activated carbon (e.g. carbon impregnated with 25 % sulphur) when mercury peaks occur, controlled by continuous mercury monitoring in the raw flue-gas. This system has been reported to be very effective as it combines effective mercury abatement with decreased operating costs due to the reduced use of sorbents.

Achieved environmental benefits

Benefits include the reduction of mercury emissions to air by adsorption on activated carbon. The carbon also adsorbs dioxins (see Section 4.5.5.5). Bag filters provide a means of dust and metals removal too. Bag filters are described in Section 2.5.3.5. It is normal for alkaline reagents to be added with the carbon; this then also allows the reduction of acid gases in the same process step as a multifunctional device. [74, TWG 2004]

Environmental performance and operational data

Operational aspects are similar to other situations where bag filters are used (see Section 4.5.2.2).

Effective bag filter and reagent injection system maintenance is particularly critical for achieving low emission levels.

Mercury is adsorbed (usually at about 95 % removal efficiency) to result in emissions to air of below 30 $\mu\text{g}/\text{Nm}^3$. [74, TWG 2004]

Mercury emissions in the range between 3 $\mu\text{g}/\text{m}^3$ and 5 $\mu\text{g}/\text{m}^3$ (yearly average) are reported for the use of separately injected sulphur-impregnated activated carbon controlled by upstream continuous mercury monitoring in the raw flue-gas. [112, EEB 2015]

In some systems where removal of mercury is carried out in wet acid scrubbers ($\text{pH} < 1$) to reduce the inlet concentration, final emission levels below 1 $\mu\text{g}/\text{Nm}^3$ are seen.

Different types of activated carbon have different adsorption capacities. Another possibility to improve mercury removal is the doping of the adsorbent (e.g. with sulphur or bromine). [74, TWG 2004]

In experiments carried out at a HWI, various types of activated carbon were used, and the consumption rate per hour required to obtain a particular mercury emission level was as follows:

- coke from coconut shells: 8–9 kg/h;
- coke from peat: 5.5–6 kg/h;
- brown coal: 8–8.5 kg/h;
- peat coal: 4–4.5 kg/h.

[64, TWG 2003]

The carbon consumption rate is similar to that mentioned for PCDD/F, as the adsorbent is generally used for both mercury and PCDD/F removal. Carbon consumption rates of 0.5 kg/t to 3 kg/t of waste are typical for MSWIs. Levels from 0.3 kg/t to 20 kg/t of hazardous waste have been reported [41, EURITS 2002]. The adsorption capacity of the reagent, the mercury inlet concentrations and the required emission level determine the required reagent dosing rate.

The fire risk is significant with activated carbon. The adsorbent may be mixed with other reagents to reduce the fire risk; 90 % hydrated lime and 10 % carbon is used in some cases. The proportion of carbon is generally higher where there are additional process stages that perform acid gas removal (e.g. wet scrubbers).

Cross-media effects

The cross-media effects are similar to those for other situations where bag filters are used (see Section 4.5.2.2). The energy consumption of bag filters is a significant aspect.

In addition, for this technique the most significant cross-media effect is the production of residues contaminated with the removed pollutant (mercury).

In cases where the solid reagent is returned (for PCDD/F destruction) in the incinerator, it is important that:

- the installation has an outlet for mercury that prevents internal pollutant build-up (and eventual breakthrough release);
- the alternative outlet removes the pollutant at a sufficient rate;
- where wet scrubbers are used, the mercury can pass into the effluent stream, from where it can then be precipitated to the solid residue using treatment techniques.

Technical considerations relevant to applicability

The applicability of bag filters is assessed in Section 4.5.2.2.

Activated carbon injection is generally applicable to new and existing plants.

Economics

The additional capital costs of the technique in processes that already use reagent injection and bag filters are minimal. See also Section 4.5.5.5.

Additional operating costs are from:

- reagent consumption;
- disposal of residues.

The cost of operations (carbon cost) is approximately EUR 125 000/yr for a facility treating 65 000 tonnes of hazardous waste per year.

The separate injection of sulphur-impregnated carbon controlled by continuous mercury monitoring in the raw flue-gas is reported to allow for operating cost savings due to the reduced overall sorbent consumption.

Driving force for implementation

Cost-effective reduction of mercury emissions to air.

Example plants

Widely used throughout Europe.

The separate injection of sulphur-impregnated carbon controlled by continuous mercury monitoring is in use at several plants in Germany, including the Hahn MWI since 2012 and the Rugenberger Damm (Hamburg) MWI (DE46).

Reference literature

[1, UBA 2001], [2, InfoMil 2002], [3, Austria 2002], [12, Achternbosch 2002], [55, EIPPCB 2002], [63, Langenkamp 1999], [41, EURITS 2002], [64, TWG 2003], [112, EEB 2015], [126, EIPPCB 2017]

4.5.6.3 Use of flue-gas condenser for flue-gas polishing

Description

This technique is described in Sections 2.4.4.5 and 4.4.11, primarily from the energy recovery point of view.

Technical description

In addition to the potential benefits of the use of such systems for energy recovery, the condensing effect of the use of a cold scrubber can condense some pollutants. This may reduce releases of pollutants to air, but only to a significant degree where the scrubber is operated at a particularly low temperature, e.g. 40 °C.

Achieved environmental benefits

The condensation of pollutants from the flue-gas provides an additional reduction of emissions to air.

The condensation of the water from the flue-gas can, when used with downstream flue-gas heating, greatly reduce plume visibility and reduce scrubber water consumption.

Environmental performance and operational data

For mercury, this technique alone cannot guarantee emission levels below 50 µg/Nm³. It is therefore only considered as an additional polishing stage.

The temperature of the scrubber effluent is critical for some pollutants, e.g. to ensure mercury is condensed and does not pass through the scrubber to be released to air. The supply of a sufficiently cold cooling medium is, therefore, critical. To be effective for metallic mercury removal, scrubber outlet temperatures of below 40 °C may be required (even lower temperatures are reported in some cases - see below).

Cooling the gas using a gas cooler (i.e. no liquid injection) down to a temperature as low as 5 °C has been reported not to give sufficiently good results for mercury abatement (DE17).

The low temperature of the flue-gases can result in condensation and, hence, corrosion in the chimney unless it is lined.

Cross-media effects

The condensed water will contain pollutants that require treatment in a water treatment facility prior to discharge. Where an upstream wet scrubbing system is applied, the effluent from the condensing scrubber can be treated in the same facility.

The technique is generally only applied where there is a readily available cooling source, for example a particularly cold (40 °C) district heating water return, which is generally only encountered in colder climates. The application of this technique in other circumstances (which is not reported) would lead to high energy costs for the cooling required.

The low temperature of the stack discharge will reduce the thermal buoyancy of the plume and hence reduce dispersion. This can be overcome by using a taller stack or one with a reduced diameter.

Technical considerations relevant to applicability

The technique is applied primarily as an energy recovery technique and where additional pollutant removal steps have already been incorporated in the installation (e.g. carbon absorption, low pH wet scrubbing).

The technique is not generally applied on its own as a means for pollution control but can be effective as a polishing stage in combination with other systems.

The table below details specific aspects relating to the use of condensing scrubbers.

Table 4.42: Assessment of the applicability of condensing scrubbers for mercury removal

Criteria	Evaluation/comments
Waste type	Because the technique is applied after the flue-gas cleaning stages, in principle the technique could be applied to any waste type
Plant size range	The technique has been applied at MSWI plants with capacities between 175 000 t and 400 000 t per year
New/existing	The technique is applied at/near the end of the FGC system and could therefore be applied to both new and existing processes
Inter-process compatibility	No specific issues
Key location factors	Only likely to be applicable where energy is not required for additional scrubber cooling, i.e. in colder northern climates, where colder district heating returns provide the energetic driving force

Economics

The total additional investment for a condensation scrubber is roughly estimated as EUR 3 million. [5, RVF 2002]

Driving force for implementation

Additional heat sales are the main driver for using the technique. The additional pollutant removal is a secondary benefit.

Example plants

Several examples of MWIs in Sweden, and a SSI in the Netherlands (NL06).

Reference literature

[5, RVF 2002], [64, TWG 2003]

4.5.6.4 Chlorite injection for elemental mercury control

Description

Addition of chlorite as an oxidising agent to convert elemental mercury to water-soluble oxidised mercury at the inlet of a wet scrubber.

Technical description

The injection of a strong oxidising agent will convert the elemental mercury into oxidised mercury and make its scrubbing possible in the wet scrubber. To avoid this agent being used up by reaction with other compounds (e.g. sulphur dioxide), it is introduced just before the spray nozzles of the first acidic scrubber. The pH of the scrubber is kept between 0.5 and 2.

When the sprayed liquid comes into contact with the acidic fumes containing hydrogen chloride, chlorite is transformed into chlorine dioxide, which is the actual active species. It should be noted that, unlike other oxidants such as hypochlorite (bleach), the chlorite or chlorine dioxide lacks the ability to introduce a chlorine atom into an aromatic ring, and therefore cannot alter the dioxin balance.

Achieved environmental benefits

The technique's benefits include reduced mercury emissions.

As a side benefit, the use of oxidants favours the removal of NO in the scrubber by oxidising it to the more soluble NO₂. This results in a reduction of NO_x emissions to air.

Environmental performance and operational data

No information provided.

Cross-media effects

Since the use of oxidants favours the oxidation of NO to a more soluble species (NO₂) in the wet scrubber, this can lead to problems related to a high nitrogen content in the waste water. [74, TWG 2004]

Technical considerations relevant to applicability

The technique is only applicable where the hydrogen chloride concentration in the raw flue-gas is at least 400 mg/Nm³.

The technique is only compatible with wet scrubbing systems.

Economics

The cost of the reagent is the limiting factor.

Driving force for implementation

No information provided.

Example plants

Bottrop and Ludwigshafen waste incineration plants (DE).

Reference literature

[64, TWG 2003]

4.5.6.5 Addition of hydrogen peroxide to wet scrubbers

Description

The main purpose of the wet scrubbing system is to separate Hg, HCl and SO₂ from the flue-gas. In the process, by adding hydrogen peroxide as an oxidising agent, SO₂ is oxidised to H₂SO₄ and absorbed by the scrubber, and most elemental mercury is oxidised to water-soluble Hg²⁺.

Technical description

The first step is a quench situated downstream of a bag filter (with carbon injection – which will absorb much of the mercury). In the quench, the flue-gas is cooled so that it is saturated. After the quench, the flue-gas comes into contact with the scrubber fluid which contains hydrogen peroxide and an additive. The scrubber fluid reacts with the flue-gas and an acidic waste water is transferred for neutralisation and precipitation of mercury.

Achieved environmental benefits

The benefits is the increased reduction of the concentration of all types of mercury in the flue-gas.

The wet scrubber also reduces HCl, HF and SO₂.

Environmental performance and operational data

Operational issues are similar to those described for other wet scrubbers (see Table 4.18).

The peak removal efficiency for mercury is typically around 99.9 %. During extended periods of high inlet concentrations, the mercury concentration in the scrubber liquid and clean gas will gradually increase. The mean removal efficiency depends on the number of stages and on the liquid discharge rate. In an installation with a low discharge rate, the mean removal efficiency will typically be in the range of 90–95 %.

Mercury emission levels below 10 µg/Nm³ can be consistently achieved, in principle regardless of the inlet concentration thanks to the very high buffer capacity.

In series with an upstream activated carbon process, the mercury removal efficiency is usually about 99.5 %.

The technique is also very efficient as a polishing stage for SO₂, HCl and HF.

Waste-water-free operation is possible by recycling the waste water into the FGC system.

Cross-media effects

The consumption rate of reagent H₂O₂ (35 wt-%) is 4–5 kg/t of hazardous waste. The consumption can increase as H₂O₂ reacts not only with mercury but also with all other oxidisable compounds like iron or heavy metals. [74, TWG 2004]

Mercury absorbed in the scrubbing liquid is precipitated in the waste water treatment stage, producing small amounts of stabilised mercury-containing sludge that requires disposal.

Energy consumption will vary depending on design parameters. A pressure drop between 1 200 Pa and 2 400 Pa can be expected for the wet scrubber, depending on the design and independent of the addition of H₂O₂.

Technical considerations relevant to applicability

This method is applicable to all types of waste incinerators using wet scrubbing. The best effect is achieved if the scrubber is situated downstream of a bag filter with carbon injection.

Economics

Investment costs can vary over a broad range, from very low costs if a suitable scrubber stage already forms part of the design up to around EUR 3 million if an entirely new scrubbing system is required (based on a 100 000 Nm³/h gas flow).

Operating costs include the cost of chemicals and, if an additional scrubber stage is required, electricity consumption to compensate for the extra pressure drop. These have been estimated to be in the range of EUR 20–35/h at a 130 000 Nm³/h plant.

Driving force for implementation

The technique can be used at both new and existing facilities that need to:

- achieve low Hg, HCl and SO₂ emission levels;
- reduce high mercury peaks.

Example plants

The Sakab Ekokem plant in Kumla (SE) (SE21) implements a MercOx system as a polishing scrubber.

Reference literature

[64, TWG 2003], [113, Sweden 2015], [128, Löthgren et al. 2007], [129, Andersson and Paur 2005]

4.5.6.6 Boiler bromine addition**Description**

Injection of bromide into the furnace or addition to the waste to enhance the oxidation of mercury during the passage of the flue-gas through the boiler, thereby promoting the transformation of the insoluble elemental gaseous mercury into water-soluble and adsorbable HgBr₂. Mercury removal is thus enhanced in downstream control devices such as wet scrubbers or dry activated carbon injection systems.

Technical description

An aqueous bromide solution such as CaBr₂ is added to the waste or injected into the furnace during combustion when the occurrence of a mercury peak is detected. At high temperatures, the bromide is oxidised to dimolecular bromine (Br₂) or atomic bromine radicals and hydrolysed bromine, which oxidise the mercury in the flue-gas. It has been shown that bromide salts are far more effective at mercury oxidation than chloride salts, because, while chlorine is scavenged by the conversion of SO₂ to SO₃, the same reaction is not enthalpically favourable with bromine. This results in a much smaller amount of bromine being sufficient for the complete oxidation of mercury than the amount of halogen reagent needed when using chlorine.

Achieved environmental benefits

The benefits are the reduction of mercury emissions to air and the efficient control of mercury emission peaks associated with occasionally high input levels in the waste.

Environmental performance and operational data

The technique improves the mercury removal efficiency of the techniques that are implemented downstream, allowing for an overall abatement efficiency of > 90 % and up to 99.8 % in combination with multistage wet scrubbers. An abatement efficiency of > 99.5 % is reported to be achievable with dry activated carbon injection systems too.

A bromine-to-mercury mass ratio of > 300 is required for the complete oxidation of the mercury contained in the flue-gas.

For the control of occasional mercury input peaks, the volume flow rate of bromide as CaBr_2 (52 wt-%) for example can be set at between 15 l and 75 l CaBr_2 (52 %) per hour depending on plant size and the magnitude of the mercury peaks. The bromide injection rate can be automatically dosed in response to the mercury levels measured in the flue-gas.

Cross-media effects

Consumption of aqueous bromide solution is a cross-media effect.

The use of bromine in the process may lead to the formation of polybrominated dioxins and/or polyhalogenated dioxins and furans.

Bromine can also cause damage to the bag filter.

The extent of these cross-media effects is limited by using the technique only in response to detected mercury peaks rather than by injecting bromide at all times as a general technique to reduce mercury.

Technical considerations relevant to applicability

The technique is not applicable to plants operating with an oxygen level near zero, such as pyrolysis plants or low-pressure gasification plants, but may be applied in downstream plant sections (e.g. at afterburning chambers where the O_2 content is sufficient).

The technique is not relevant for plants burning waste with a high chlorine content.

Economics

Investment costs are reported to be low, ranging from EUR 10 000 to around EUR 250 000 depending on local standards for the installation, and covering an adequate storage tank for the bromide solution, dosing pumps and injection lances.

Operating costs are essentially related to the consumption of bromide as an oxidiser and depend on the overall mercury content in the waste and are therefore variable. They are reported as ranging between less than EUR 20 000/yr and EUR 120 000/yr.

For a site operating two hazardous waste incinerators and one multiple-hearth kiln for sewage sludge combustion, the reported consumption over a period of 13 years is between 25 m³ and 125 m³ bromide solution per year.

Driving force for implementation

- Compliance with emission legislation.
- Suppression of mercury peaks.
- Potential cost savings compared with the use of other oxidisers.

Example plants

The technique has been in use in Germany since 2002 at four rotary kiln incinerators for the combustion of hazardous wastes at Currenta GmbH&Co OHG; since 2004 at two stationary fluidised bed incinerators for communal sewage sludge at Emschergenossenschaft-Lippeverband in Bottrop; and since 2008 at another two stationary fluidised bed incinerators for communal sewage sludge at WWTP Karlsruhe-Neureuth in Karlsruhe.

It has also recently been implemented at three rotary kiln incinerators for the combustion of hazardous wastes of SARPI-VEOLIA in France, which are fitted with three different flue-gas cleaning systems: a dry FGC system based on activated carbon and hydrated lime, a similar semi-dry FGC system as the first stage with an additional tail-end scrubber, and a multistage wet FGC system.

Reference literature

[115, Vosteen et al. 2015], [127, EIPPCB 2017]

4.5.6.7 Fixed-bed adsorption of mercury

The use of this technique, and its benefits for mercury reduction, cross-media effects and other issues are described in Section 4.5.5.6.

Mercury is adsorbed to give emissions to air typically below 20 µg/Nm³.

4.5.6.8 Fixed Sorbent Polymer Catalyst (SPC) systems

Description

Fixed sorbent system utilising a Sorbent Polymer Catalyst (SPC) that captures both elemental and oxidised mercury and removes SO₂. It can be used in a wet scrubber, or as a standalone unit.

Technical description

Open-channel modules with a low associated pressure drop are installed downstream of a dust collector, where they continuously remove mercury from the flue-gas. The mercury is chemisorbed into the structure, forming a stable species which will not desorb or leach.

The modules are replaced after several years of use once they are loaded with chemisorbed mercury. No sorbents or chemicals are injected into the gas stream, resulting in very little solid waste compared with a typical carbon injection system. SO₂ is also removed as a co-benefit by oxidation to sulphuric acid, which is typically processed in the wet scrubber.

The modules may be installed inside an existing wet scrubber above the mist eliminators at the outlet of the scrubber. As a self-standing tailpipe solution, they can typically be installed immediately before the stack, either in the outlet of a wet scrubber or immediately following a wet scrubber or a wet ESP.

Achieved environmental benefits

- Reduction of mercury emissions to air, thus avoiding contamination of process dust or process waste water.
- Minimal solid waste generation (modules replaced every several years of operation).
- Low energy penalty since the low pressure drop obviates the need for an additional ID fan.
- SO₂ emissions to air are also reduced as a co-benefit.

Environmental performance and operational data

The technique is implemented as a modular design, with each module removing approximately the same percentage of mercury in the flue-gas, which depends on the flue-gas velocity. The overall removal percentage is determined by the number of modules stacked in series. For a flue-gas velocity of 4 m/s, a 60 cm high stack is reported to remove 40–50 % of the mercury in the flue-gas, meaning that 80–90 % mercury is removed by a 180 cm high stack.

The technique thus provides for a fixed percentage removal of inlet mercury in the flue-gas, but no significant operational flexibility or buffer capacity. As such, it may be sufficient as a sole mercury control technique in plants where the mercury load and its variability are relatively low, e.g. in sewage sludge incinerators, but not for example in the case of merchant hazardous waste incinerators.

A maximum operating temperature of 80 °C is reported. If necessary, a cooling device such as an evaporative cooler may be used upstream. Pre-dedusting is required, although the technique is tolerant to moderate particulate loadings such as after an ESP. The open-channel modules can be washed in use, and process dust is rinsed off of the surfaces with water.

The technique does not involve any moving parts or require the injection of chemicals or sorbents. Minimal washing with process water is required.

At six sewage sludge incineration lines in the US operated by the Northeast Ohio Regional Sewer District and by the Metropolitan Sewer District of Greater Cincinnati, mercury emission reductions ranging between 60 % and 97 %, resulting in emission concentrations between $< 1 \mu\text{g}/\text{Nm}^3$ and $9 \mu\text{g}/\text{Nm}^3$ (converted to 11 % O_2), were reported. SO_2 reductions ranging between 78 % and 98 % were also reported at the same sites.

A pressure drop of 0.25–0.5 kPa is reported.

Cross-media effects

The main cross-media effect is the generation, after a few years of use, of mercury-laden spent polymer catalyst. Considering that a 20 kg module may capture around 1 kg mercury before replacement is needed, the amount of waste generated is much lower than with activated carbon injection systems.

Technical considerations relevant to applicability

The technique is generally applicable to new plants.

Adaptability to existing plants may be constrained by the space requirements for an additional process unit and, in plants fitted only with dry FGC techniques, by additional flue-gas cooling requirements.

Economics

Investment costs are reported to be highly site-specific, but in general substantially lower than for fixed-bed adsorption. In the cases of two sewage sludge incinerators already fitted with a wet scrubber in the US, investment costs between USD 225 000 and USD 450 000 were reported, which included the costs for a separate vessel constructed to hold the modules, placed after the scrubber (either on top, or downstream).

Operating costs are typically reported to be low.

Driving force for implementation

Reducing mercury emissions while limiting cross-media effects.

Example plants

In the US, 16 sewage sludge incinerator sites use the Gore Mercury Control System technique.

Reference literature

[119, EEB 2015], [120, Smith et al. 2017]

4.5.7 Techniques to reduce emissions of other substances

4.5.7.1 Use of specific reagents for iodine and bromine reduction

Description

This technique is briefly described in Section 2.5.4.1.

Special reagents, e.g. sodium thiosulphate or sodium bisulphite, can either be added as required to an existing wet scrubbing system for the treatment of particular batches of waste (when knowledge of the waste content is critical) or added routinely to an additional stage of the wet scrubbing system (when consumption of reagent may be higher).

Technical description

In the halogen scrubber, any free halogens are reduced to halogen hydrides by reaction with an alkaline $\text{Na}_2\text{S}_2\text{O}_3$ solution. Together with the remaining SO_2 , the halogen hydrides are then removed from the flue-gas by dissolution.

The halogens in question are bromine and iodine, mainly originating from flame-retardants and medical waste. As fluorine and chlorine are stronger oxidising agents, both are totally reduced to hydrides.

It is also possible to reduce iodine and bromine emissions to air by injecting sulphur-containing wastes or SO₂ in the furnace. [64, TWG 2003]

Achieved environmental benefits

A yellow/brown or purple flue-gas can be seen in some cases when appreciable concentrations of bromine or iodine (respectively) pass through the FGC system. This is prevented by targeted or regular Na₂S₂O₃ addition.

Environmental performance and operational data

It has not been possible to control the process by on-line redox measurement, due to a mixture of several interfering redox processes in the scrubber water. The addition is, therefore, controlled by the SO₂ concentration in the raw gas. If the waste contains enough sulphur, no additional reduction of halogens is required – this reflects the alternative option of metered burning of higher sulphur waste or SO₂ injection mentioned above.

Cross-media effects

The consumption of Na₂S₂O₃ depends on the sulphur content of the waste, with its addition being controlled according to the SO₂ concentration in the raw gas. If the waste contains enough sulphur, no additional reduction of halogens is required.

The removed pollutants are transferred to the effluent; subsequent treatment may therefore be required.

Where SO₂ or higher sulphur wastes are added, this will require a change in the operational set-up of subsequent FGC stages to allow for the altered standard waste chemistry. Changes in the sulphur/chlorine balance can also affect PCDD/F reformation rates.

Technical considerations relevant to applicability

The technique is generally applicable to any plant fitted with a wet scrubber.

It is mainly relevant for HWIs or other installations where concentrations of iodine and bromine in the waste incinerated are highly variable and/or difficult to predict/control, e.g. wastes from laboratories or chemical/pharmaceutical wastes. In general, these are HW installations.

Economics

The yearly consumption of Na₂S₂O₃ for each of the three incineration lines, as an average, is approximately 50 tonnes. At a price of EUR 0.5/tonne, the total costs for running this third step (excluding power) for the scrubber pumps etc. are EUR 25 000/yr per line.

Costs for targeted addition of reagent are likely to be lower, but additional resources may be required for control and management of incoming wastes.

Costs for addition of reagent to an existing wet scrubbing system are limited mainly to the reagent costs and are, therefore, significantly less than the cost of adding a separate scrubbing stage.

Costs of SO₂ injection are the gas costs. The addition of higher sulphur waste will depend on the availability of such waste.

At a HWI in Denmark, a third scrubber stage was added at a cost of approximately EUR 600 000 (in the year 2000).

Driving force for implementation

- Control of iodine and bromine emissions is required.
- Cases where the concentrations of iodine and bromine in the waste incinerated are highly variable and/or difficult to predict/control.

Example plants

Targeted dosing is used at many European HWIs. An additional scrubber stage was installed at a HWI in Denmark.

Reference literature

[25, Kommunikemi 2002], [64, TWG 2003]

4.6 Waste water treatment and control

The general principles to be applied in respect of the selection and operation of waste water treatment systems are outlined in the BREF on Common Waste Water and Waste Gas Treatment/Management Systems in the Chemical Sector (CWW). This section of this document therefore only addresses issues that have been identified as important for, or specific to, the WI sector.

An optimal incineration process is an important condition for the effective control of emissions to water. Incomplete incineration has a negative effect on flue-gas and fly ash composition, by the increased presence of organic compounds with a polluting and/or toxic character. These in turn can impact on the content of the scrubber effluent.

The techniques to be considered in respect of reducing the pollutant content of the flue-gases (and hence reducing the potential risk of transfer to scrubber effluents) are outlined in Sections 4.1 and 4.3.

4.6.1 Application of waste-water-free flue-gas cleaning techniques

Description

Techniques to consider are:

- use of dry sorbent injection or a semi-wet absorber;
- use of a wet scrubber followed by evaporation of the produced effluent;
- recycling of waste water from the wet flue-gas cleaning system.

Technical description

Waste-water-free flue-gas cleaning can be achieved by:

- use of dry and semi-wet processes: these do not give rise to waste water;
- wet processes that use evaporation: wet FGC gives rise to waste water; however, under certain conditions this waste water can be recirculated into the process and evaporated.

These processes are described in Section 4.5.3.

Achieved environmental benefits

- No discharge of waste water.
- Avoidance of resource consumption associated with waste water treatment.
- Recovery of salts by evaporation.

Environmental performance and operational data

Dry and semi-dry FGC systems do not generate waste water. Other waste water from other on-site processes or rainwater may be recycled in semi-wet or wet systems.

Wet processes generate waste water that, instead of being discharged after treatment, can be recycled or evaporated either on-line or in a specific evaporation unit. The amount of waste water from a wet process is typically 0.2 m³/t of waste. Wet scrubber effluent is neutralised (e.g. with hydrated lime or milk of lime). Complexing agents are also injected to treat heavy metal compounds. Then the treated waste water is sprayed into an evaporative cooling tower and vaporises using the energy of the flue-gas at the boiler outlet.

Evaporation of effluent may cause risk of fouling in the evaporative cooling tower. [74, TWG 2004]

Cross-media effects

- Increase in energy consumption. The energy consumption of the evaporation unit may not be significant if supplied from otherwise wasted heat.
- Increase in residues production.

Technical considerations relevant to applicability

The technique is generally applicable.

Economics

Where a discharge of effluent is acceptable, there is reduced incentive to adopt systems that eliminate this discharge. Possible examples include marine environments that can absorb post-treatment salty waste waters.

Energy costs for a separate evaporation plant may be high.

Where solid waste disposal costs are high, there may be benefits in adopting wet flue-gas treatment with (or without where a discharge is possible) evaporation owing to the reduced solid waste arising.

An outlet for recovered salt arising in separate evaporation systems will avoid the need to pay disposal charges for this fraction. Impurities have proven to complicate this in some cases. [74, TWG 2004]

Driving force for implementation

The lack of availability of a water discharge outlet is a key driver.

Example plants

Evaporation is carried out at a number of installations in Germany and gives rise to wet FGC installations that do not discharge an effluent.

Zero-effluent production FGC (i.e. non-wet FGC) systems are widely used throughout Europe.

FR56 (wet process + evapocondensation of the waste water) and FR33 (semi-wet + wet processes). [74, TWG 2004]

Reference literature

[2, InfoMil 2002], [64, TWG 2003], [74, TWG 2004]

4.6.2 Dry bottom ash handling

Description

Dry, hot bottom ash falls from the grate onto a transport system and is cooled down by ambient air. No water is used in the process. Useful energy is recovered by using the cooling air for combustion.

Technical description

The discharger is operated without water and the bottom ash is discharged in dry form from the combustion system. The ram-type bottom ash discharger is used in unchanged form but with an air separator and a dedusting system (e.g. cyclone separator).

The air sealing to the combustion chamber is achieved by piling up the bottom ash in the ash pit. The dry discharged bottom ash is conveyed directly to an air separator.

The fine fraction and bottom ash dust are extracted in a predefined manner. Depending on the extraction speed, the fine fraction and dust particle size is set to values ≤ 1 mm to ≤ 5 mm.

The air separation area is enclosed by a housing, constantly maintained under subatmospheric pressure, thereby also preventing false air from entering the furnace or dust from entering the boiler house.

The surface temperature of the discharger is the same range (40–60 °C) as in a wet-type discharger.

Typically, the following three material flows are separated from the dry-discharged bottom ash by means of air separation and dust extraction:

- coarse fraction (> 1 mm), enriched with recoverable metals;
- fine fraction (≤ 1 mm), nearly metal-free;
- bottom ash dust (≤ 100 μm).

The latter two fractions are discharged out of the air separator with the air flow and conveyed to a dust extraction system, which ensures that they are separated from the air flow. The unburdened air, containing a minimal residual load of bottom ash dust, is conveyed to the combustion air system or further dedusted before release.

Figure 4.9 shows the general scheme of a dry bottom ash discharge system.

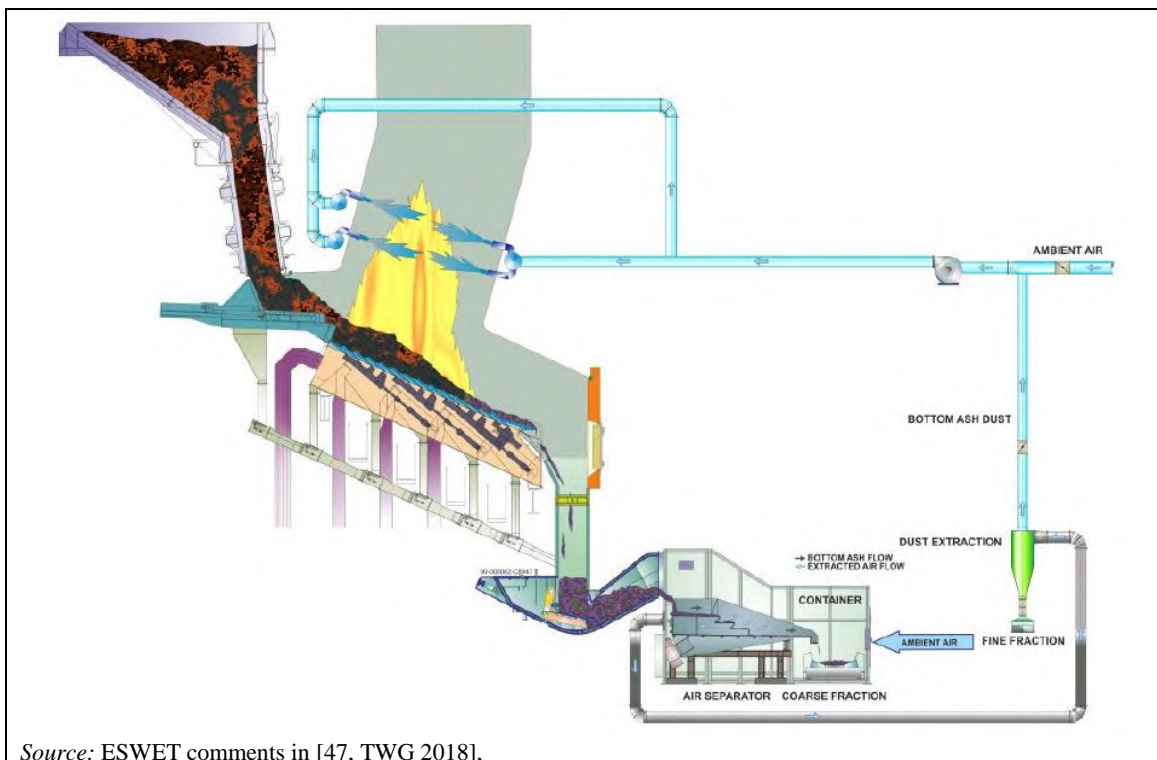

Figure 4.9: Scheme of a dry bottom ash discharge system

See also the LCP BREF.

Achieved environmental benefits

- Reduced water consumption.
- Improved energy efficiency.
- Improved recovery of metals, as they are easier to separate from dry-discharged bottom ashes than from wet-discharged bottom ashes.

Environmental performance and operational data

No water is used. Useful energy is recovered by using the cooling air for combustion. The amount of heat recovered depends mainly on the following operating parameters:

- bottom ash production rate;
- bottom ash temperatures at grate discharge (generally ranging from 350 °C to 500 °C) and at final discharge (generally < 100 °C).

If necessary (e.g. for fire safety), the bottom ash discharger may be flooded with water at any time.

Cross-media effects

The dry bottom ash discharge produces a high amount of dust and requires proper housing and dedusting facilities.

Technical considerations relevant to applicability

Only applicable to grate furnaces.

There may be technical restrictions that prevent retrofitting to existing grate furnaces.

Economics

The dry bottom ash discharge enables a more effective metal separation combined with a better quality of the recovered metals, resulting in increases in the achievable metal price and revenues. An additional benefit is the reduction of transport costs due to the weight reduction of around 20 wt-% due to the absence of water.

The internal rate of return of the investment associated with the increased amount of non-ferrous metals recovered is in the range of 15–26 % for a plant with a throughput of 100 000 t/yr, and of 35–50 % for a plant with a throughput of 160 000 t/yr. [\[130, Martin and Hanenkamp 2017\]](#).

Driving force for implementation

- Improvement in ash quality.
- Increased non-ferrous metals recovery from incinerator bottom ash treatment.

Example plants

ACEA San Vittore del Lazio (IT), GESPI Augusta (IT), KEBAG AG Zuchwil (CH), KVA Horgen (CH), ERZ Zurich (CH), KEZO Hinwil (CH), SATOM Monthey (CH).

Reference literature

[\[130, Martin and Hanenkamp 2017\]](#). [\[131, Magaldi 2017\]](#)

4.6.3 Use of boiler drain water

Description

Techniques to consider are:

- feeding of the boiler water drainage into a semi-wet or wet scrubber, or a quench system;
- treating the boiler water drainage to recycle it in the incineration process itself.

Technical description

Boiler water requires regular draining in order to reduce the levels of the dissolved solids. This waste water stream can be fed directly to the scrubbers (semi-dry and wet) or to a quench, instead of separate treatment/discharge.

Another option is to treat it and send it back to the boiler. The water coming from the boiler is cooled down in a heat exchanger where the heat is exchanged with cold demineralised water going to the deaerator (in this way the waste heat is also recovered) to a level which allows further treatment. The cooled water goes to a buffer tank for temporary storage. The water, at temperatures below 40 °C, is sent from the tank to an activated carbon filter (to remove the ammonia content), then sent to an ion exchange column (with anionic and cationic resins) to reach a targeted silicon content. Then the water is ready to be sent to the deaerator and recycled. [96, Italy 2016]

Achieved environmental benefits

Reduction in water consumption by replacement of scrubber feed water.

Environmental performance and operational data

No information provided on the feeding of boiler waste water to scrubbers.

It is important to check if the quality of the effluent is suitable for the process, in particular to prevent the risk of fouling due to salt precipitation (e.g. calcium phosphate). [74, TWG 2004]

At IT10, a water tank receives the water from the boilers. When the tank is full, the treatment starts. The operating range for the flow is between 0.7 m³/h and 2 m³/h. The system uses a 1.1 kW pump; 20 l/min of compressed air are used to control the valves. The consumption of HCl and of NaOH for the regeneration of resins in the ion exchange bed are both of 30 l/month.

The residues produced are:

- activated carbon filter: 50 kg (substitution every 8 years);
- quartz: 50 kg every 8 years;
- anionic and cationic resins: 100 kg every 8 years;
- waste water produced during regeneration (every 2 weeks): 4 m³/month.

All the water from continuous blowdown of boilers is recovered.

The temperature of the water at the inlet of the activated carbon filter has to be lower than 40 °C.

The equipment used for this technique has a very long lifetime (substitution of filters and resins every 8 years).

The water conductivity and silica concentration are checked downstream of the ion exchange bed.

The energy that the treatment requires is compensated by the reduced energy needed for the supply of fresh water. [96, Italy 2016]

Cross-media effects

Slight increase in energy use and in raw materials consumption.

Technical considerations relevant to applicability

The feeding of boiler waste water to the scrubbers is only applicable to gas cleaning systems that require a water feed (i.e. not dry systems unless conditioning feed water is added).

The treatment of boiler waste water is generally applicable.

Economics

No information was provided on the feeding of boiler waste water to scrubbers.

The investment cost for the treatment of boiler waste water is around EUR 40 000 (2006), while the operating cost, including the maintenance, is EUR 1 600 per year.

The savings are:

- approximately EUR 294 000 per year due to the avoided cost for waste water disposal;
 - approximately EUR 650 per year due to the energy saved for the groundwater suction;
- [96, Italy 2016]

Driving force for implementation

Cost savings.

Example plants

MHKW Bamberg (DE), Rea Dalmine (IT) and many other MWIs in Europe.

Reference literature

[2, InfoMil 2002], [96, Italy 2016]

4.6.4 Recirculation of effluents to the process instead of discharge**Description**

Because the incineration process itself provides a means of concentration and removal of pollutants from waste streams, it is possible to feed low- or medium-volume waste water effluents into the incineration process, or into the flue-gas cleaning process, at appropriate points. The correct implementation of this technique does not negatively affect the operation of the incineration plant or its environmental performance.

These practices may include:

- the use of boiler drain water as water supply for wet scrubbers (see Section 4.6.3);
- the use of some laboratory waste water streams containing low levels of contamination as make-up water for scrubber feeds;
- sending the leachate from open-air bottom ash or other storage areas to the wet bottom ash discharger;
- the use of collected rainwater as a scrubbing medium;
- the recirculation of condensates;
- the reuse of cooling water from electricity production;
- the injection of the permeated water from boiler water preparation.

[74, TWG 2004]

Achieved environmental benefits

If well designed and operated, such a system can allow the waste incinerator to:

- concentrate inorganic pollutants into solid wastes (e.g. with FGC residues or WWT residues);
- reduce water consumption;
- eliminate, or limit, the need for effluent discharges.

Cross-media effects

Where it is necessary to treat the effluent stream to improve its quality in order to allow recirculation, this will result in additional energy and materials consumption (and costs) that could be sufficiently large to negate the benefits of the eventual recirculation. Such an assessment will depend greatly upon the details of local circumstances.

It is essential that the recirculation of materials within the installation is accompanied by outlets for those materials that may accumulate. Accumulation of some substances (notably Hg) can lead to build-up and eventual breakthrough and release. To avoid this, a correct assessment and provision of sinks for such substances is required.

In particular, these techniques tend to cause a concentration of pollutants in the solid waste stream.

Operational data

It is possible to identify opportunities for recirculating partially contaminated waste streams for other uses within the installation by assessing overall flows and exchanges of mass. Such assessments are sometimes called Pinch Assessments or Materials Exchange Networks. Such tools, when applied to effluent systems, provide a means of assessing the possibility of effluent recirculation, taking into account the quality requirements of the inputs to the process units themselves and the overall objective of the system to reduce emissions.

Applicability

The technique is generally applicable.

Economics

Costs will increase if interim effluent treatment is required.

Savings may be made by reducing water consumption and discharge costs.

Driving force for implementation

- the lack of availability of a water discharge outlet;
- the water supply being limited by dry climate.

Example plants

MSWI with zero discharge: Azalys, Ouarville [74, TWG 2004].

Reference literature

[64, TWG 2003], [72, El-Halwagi 1997], [74, TWG 2004]

4.6.5 Segregation of waste water streams and separate treatment, depending on the pollutant content

Description

Waste water streams (e.g. surface run-off water, cooling water, waste water from flue-gas treatment and from IBA treatment) are segregated to be treated separately based on their pollutant content and on the combination of treatment techniques required. Uncontaminated waste water streams (e.g. clean rainwater, cooling water) are segregated from waste water streams that require treatment.

Technical description

This technique involves the separation of the drainage of clean rainwater so that it does not mix with streams that are potentially or actually contaminated.

Achieved environmental benefits

- Reduction in the volume of waste water requiring treatment.
- The remaining polluted fraction has a higher concentration and can therefore be treated more effectively.

Environmental performance and operational data

If the incinerator is located in a community with only one sewer for both polluted waste water and rainwater the separate collection of unpolluted streams is of limited benefit, unless it can be suitably treated for direct discharge to the environment. [74, TWG 2004]

Cross-media effects

None reported.

Technical considerations relevant to applicability

The technique is generally applicable to new plants.

It is applicable to existing plants within the constraints associated with the configuration of the water collection systems.

Economics

Retrofit costs can be significant at existing sites, but the technique can be installed efficiently at new sites.

Savings may be made from the reduction of the water-holding capacity needed on the site.

Driving force for implementation

In some countries, the mixing of uncontaminated rainwater with other effluents is not permitted.

Example plants

Applied throughout Europe.

Reference literature

[64, TWG 2003], [74, TWG 2004]

4.6.6 Application of physico-chemical treatment to the effluent from the wet flue-gas cleaning system and other contaminated streams

Description

The conversion of dissolved pollutants into insoluble compounds by adding chemical precipitants. The precipitates are subsequently separated by sedimentation, flotation or filtration. If necessary, this may be followed by microfiltration or ultrafiltration. Typical chemicals used for metal precipitation are lime, dolomite, sodium hydroxide, sodium carbonate, sodium sulphide and organosulphides. Calcium salts (other than lime) are used to precipitate sulphate or fluoride.

Technical description

A description of the technique is provided in Section 2.6.3.1 (physico-chemical treatment in general) and Section 2.6.3.2 (use of sulphides).

In general, the provision of a waste water treatment system for wet scrubber effluents, as well as for waste water collected in the plant, is considered essential. [64, TWG 2003]. [74, TWG 2004]

Achieved environmental benefits

Reduction of water emissions.

Environmental performance and operational data

With the application of sulphides to increase heavy metal precipitation from wet scrubber effluents, a 99.9 % reduction of mercury levels can be achieved in treated effluents. Emissions to water of mercury below 0.003 mg/l can be achieved. Other substances are also reduced.

Problems with encrustation and clogging of pipes by sedimentation may occur. [74, TWG 2004]

Cross-media effects

Consumption of energy and raw materials in the WWTP.

Technical considerations relevant to applicability

This technique is applicable to all incineration installations with wet scrubbing. It may also be applicable to other waste water streams that require such treatment prior to their discharge. [74, TWG 2004]

Economics

Additives and reagents can be costly. [74, TWG 2004]

Driving force for implementation

Environmental legislation requirements.

Example plants

Widely applied throughout Europe in installations with wet scrubbing.

Reference literature

[2, InfoMil 2002], [1, UBA 2001], [64, TWG 2003], [74, TWG 2004], [101, Sweden 2016]

4.6.7 Stripping of wet scrubber waste water containing ammonia

Description

Techniques to consider are as follows:

- Stripping: The removal of ammonia from waste water by contact with a flow of a steam current in order to transfer it to the gas phase. The ammonia is removed from the stripping gas in a downstream treatment and may potentially be reused.
- Reverse osmosis: A membrane process in which a pressure difference applied between the compartments separated by the membrane causes water to flow from the more concentrated solution to the less concentrated one.

Technical description

The technique is described in Section 2.6.3.4.

Ammonia slip can result from the use of ammoniacal reagents for NO_x reduction. Slip is higher when reagent dosing is high or poorly optimised, and is generally higher with SNCR than SCR systems. The ammonia is highly soluble in water and will accumulate in the effluent from downstream wet scrubbers. Using stripping or reverse osmosis, it is possible to remove ammonia from wet scrubber effluents. The ammonia collected in this way is returned to the furnace to avoid the transfer of this pollutant from water to air and to enable its reuse as a NO_x reduction reagent.

[74, TWG 2004]

Achieved environmental benefits

- Reduction of ammonia in the discharged scrubber effluent.
- Reduction in ammonia consumption where recirculated to be reused as the NO_x reduction reagent.

Environmental performance and operational data

The technique is applied at WI installations with wet scrubbers downstream of the ammonia/urea reagent injection for NO_x reduction. The abatement efficiency of the stripping under normal operating conditions is about 99 %. [101, Sweden 2016]

The technique is of particular benefit where ammonia slip levels downstream of the boiler are higher. This tends to occur where:

- there are particular technical difficulties for the optimisation of the SNCR reagent injection/mixing/temperature;
- reagent injection levels are relatively high (e.g. where high NO_x abatement is required).

[74, TWG 2004]

The handling of ammonia solutions requires care to reduce exposure risks.

Cross-media effects

Ammonia stripping requires significant additional energy consumption for its operation and there is a risk of fouling. [74, TWG 2004], [101, Sweden 2016]

Technical considerations relevant to applicability

The technique is generally applicable.

Economics

Operating and capital costs for the ammonia stripper may be partially offset by the reduction in reagent costs when the recovered ammonia is recirculated to the SNCR reagent injection.

Driving force for implementation

The main driving force for the technique is the restriction of ammonia levels in the effluent discharged from the site.

Example plants

SE02, SE03.

Reference literature

[55, EIPPCB 2002], [64, TWG 2003], [74, TWG 2004], [101, Sweden 2016]

4.6.8 Separation of mercury using ion exchange**Description**

The removal of ionic pollutants from waste water and their replacement by non-polluting ions by transferring them to an ion exchange resin. The pollutants are temporarily retained and afterwards released into a regeneration or backwashing liquid.

Technical description

The raw acids and the ionically bound metals in the waste water from the first acidic stage of the wet scrubber are passed through a mercury ion exchanger. Mercury is separated off in a resin filter. Then the acid is neutralised using milk of lime.

Achieved environmental benefits

Highly reliable abatement of mercury.

Environmental performance and operational data

In Table 4.43, the environmental performance of plants incinerating non-hazardous waste and using ion exchange for the reduction of mercury emissions is shown.

Table 4.43: Mercury emissions to water from plants using ion exchange

Plant	Techniques	Emissions				
		Max. (mg/l)	Avg. (mg/l)	Min. (mg/l)	Flow (kg/yr)	Direct/ Indirect
AT04	A, CPs, IE Se, Fi, FI	NA	0.001	NA	0.044	Direct
AT05	A, CPh, CPs, IE, C, Se, Fi FI	0.004	0.00175	0.001	0.318	Direct
AT09	A, CPs, IE, Se, Fi, FI	NA	0.0006	NA	0.003	Indirect
DE44	IE	NE	NE	NE	NE	No emission
DE54	IE	NE	NE	NE	NE	No emission
DE58	A, CPh, CPs, IE, Se, Fi	NE	NE	NE	NE	No emission
DE80	CPh, IE, Fi	0.001	0.0002	0.0001	0.009	Direct
DK01	A, CPs, IE, Fi, FI	NA	0.00082	NA	0.04	Direct
NO01	A, CPh, CPs, IE	0.0002	0.0001	0.00001	0.001	Direct

NB:
 NA = Not available; NE = No emission to water; A = Adsorption on activated carbon; C = Coagulation; CPh = Chemical precipitation with hydroxide; CPs = Chemical precipitation with sulphides; Fi = Filtration; FI = Flocculation; IE = Ion exchange; RO = Reverse osmosis; Se = Sedimentation.
 Source: [81, TWG 2016]

Cross-media effects

The resin filter will require regeneration which results in the transfer of the abated mercury.

Technical considerations relevant to applicability

The technique is generally applicable.

Economics

The technique is reported to be expensive in relation to alternatives.

Driving force for implementation

No information provided.

Example plants

AT04, AT05, AT09, DE44, DE 54; DE58, DE80, DK01, NO01, SE20.

Reference literature

[64, TWG 2003], [81, TWG 2016]

4.6.9 Separate treatment of effluents arising from different wet scrubbing stages

Description

The technique involves the separation and separate treatment of the acid and alkaline wet scrubber streams in order to allow improved optimisation of the effluent and increased options for the recovery of components of the effluent streams.

Technical description

The technique is described in Section 2.6.3.5.

Achieved environmental benefits

- Emissions to water can be reduced further than with combined treatment.
- Optimisation of separate streams reduces reagent consumption and allows targeted treatment.
- Gypsum can be recovered from sulphur scrubbers (see Section 4.6.11); this reduces sulphur discharges with the waste water and the sulphur content of solid residues from the WWTP.
- HCl may be regenerated from first-stage acid scrubbers (see Section 4.6.10).

Environmental performance and operational data

There is additional complexity due to the operation of two WWTP lines. More complexity means higher investment and operating costs and that more space is required.

An outlet for the recovered materials is required. This may be complicated due to impurities. [74, TWG 2004]. For instance, there may be problems recovering HCl as HF may give rise to impurities.

Cross-media effects

Energy consumption.

Technical considerations relevant to applicability

The technique is generally applicable to new plants. It is applicable to existing plants within the constraints associated with the configuration of the drainage system.

Economics

The cost of replacing existing combined treatment systems is likely to be very high.

Operating and capital costs for the second WWTP may be partially offset by reduced disposal costs when gypsum and salts like NaCl or CaCl are recovered. [74, TWG 2004]

Driving force for implementation

The existence of markets for the recovered materials may drive the adoption of this system.

The main reason is generally the application of particularly low effluent discharge emission limits, possibly to protect a sensitive water body.

Example plants

AT03, AT04, AT08, AT09, DE30, DE40, DE43, DE51, DE58, DE62, DE74, DE78, DK01, DK02.

Reference literature

[64, TWG 2003]

4.6.10 Recovery of hydrochloric acid from wet scrubber effluents

Description

Hydrochloric acid is recovered from the waste water coming from the first-stage scrubber by stripping.

Technical description

See Section 2.6.3.8 for a description of this process.

Achieved environmental benefits

- Recovery of HCl.
- Reduction of solid residues.

Environmental performance and operational data

This technique is most suited to those plants which incinerate high amounts of chlorinated waste. [74, TWG 2004]

In the recovery of HCl, a product with a concentration of about 30 % hydrochloric acid is produced from untreated acid with a concentration of about 10 %.

Data from two plants in Germany are shown in the table below.

Table 4.44: Quantity of HCl (30 %) recovered per tonne of waste

Year	kg of HCl recovered per tonne of waste	
	DE47	DE48
2000	10	10
2001		12.5
2002	10.6	13

Source: [64, TWG 2003] [74, TWG 2004]

It is vital that systems and materials are suitable to avoid/limit corrosion in the recovery system.

Recovering HCl reduces the amount of solid salt residues arising from the installation by approximately 50 % [73, Rijpkema 2000].

The use of one plant was reported to have been discontinued following difficulties with HF contamination of the recovered HCl.

The recovered hydrochloric acid may be used, e.g. for pH control.

Cross-media effects

- Energy requirements.
- Use of chemicals in the recovery process.

Technical considerations relevant to applicability

The technique is generally applicable.

Economics

Significant investment is necessary; therefore these procedures are only applicable where sufficient flue-gas loading with chlorine is available. Maintenance and operating costs can also be high owing largely to the highly corrosive nature of the material being recovered. [74, TWG 2004]

The benefits of the products may not be that significant (there are market fluctuations) but waste disposal costs are reduced. Eco-efficiency analyses have shown that this technique is economical in some circumstances compared to other procedures.

Driving force for implementation

- Raw material recovery.
- Savings in neutralisation costs.

Example plants

Hazardous waste incinerators using rotary kilns (DE22, DE23) and the municipal solid waste incinerator DE30.

Reference literature

[64, TWG 2003], [132, Stultz et al. 1992]

4.6.11 Recovery of gypsum from wet scrubber effluent**Description**

Optimisation of the quality of the calcium-based reaction residues generated by the wet scrubber so that they can be used as a substitute for mined gypsum.

Technical description

This technique involves the separate treatment of the effluent from the high pH (6–8), sulphur dioxide removal stage in wet scrubbers; this can allow the production of saleable gypsum.

In a multistage wet scrubber, at the earlier stages the dust and the HCl are removed from the flue-gas. Then the flue-gas is passed to the SO₂ cleaner, where the SO₂ is absorbed by oxidation to sulphate by the addition of milk of lime or of a limestone suspension.

The gypsum suspension formed is removed and thickened in a hydrocyclone and passed to a container. The gypsum suspension is then dehydrated in a centrifuge. The gypsum is then cleaned with condensate to remove the remaining soluble contaminants. Further centrifuging is carried out to a remaining humidity of less than 10 wt-% and, if needed, until it is possible to achieve the whiteness required for marketing of this gypsum. [74, TWG 2004]

Achieved environmental benefits

- Recovery of gypsum.
- Reduction of the sulphate content of the discharged effluent by its removal from the waste water.
- Where reuse outlets can be found this reduces gypsum disposal, either on its own or with other residues.
- Reduction of solid residues.
- When mixing together with hydroxide and sludge from the first waste water cleaning stage, which is very difficult to dewater, the dewatering effect of this mixture is greatly improved up to 70 % dry matter.

[74, TWG 2004]

Environmental performance and operational data

Data from two plants Germany (DE47 and DE48) are shown in the table below.

Table 4.45: Quantity of gypsum recovered per tonne of waste treated

Year	kg of gypsum recovered per tonne of waste	
	DE47	DE48
2000	3.5	1.7
2001		3.9
2002	3.5	3.3
<i>Source: [64, TWG 2003]</i>		

Cross-media effects

Consumption of energy and materials in the treatment/recovery plant.

Technical considerations relevant to applicability

The technique is generally applicable within the constraints associated with the required gypsum quality.

Economics

Significant investment is necessary; therefore these procedures are only applicable where sufficient flue-gas loading with sulphur is available.

The economic income benefits of the products may be limited (due to market fluctuations) but waste disposal costs are reduced. Eco-efficiency analyses have shown that these plants are economical compared to other procedures. [64, TWG 2003]

Driving force for implementation

Availability of outlets for the recovered material.

Example plants

AT03, AT04, AT08, AT09, DE30, DE40, DE43, DE51, DE58, DE62, DE74, DE78, DK01, DK02.

Reference literature

[1, UBA 2001], [64, TWG 2003]

4.6.12 Crystallisation

Description

The removal of ionic pollutants from waste water by crystallising them on a seed material such as sand or minerals, working in a fluidised bed process.

Technical description

The crystallisation device consists mainly of:

- the cylindrical reactor with bottom influent and top effluent;
- seed material, i.e. pellets of filter sand or minerals, kept in a fluidised bed condition;
- the circulation system with a recirculation pump.

The principle of the circulation system is to mix the influent waste water with the circulation stream with the lower anion or metal concentration. Because of the circulation system, the reactor can work more flexibly, e.g.:

- fluctuations in the influent flow and composition are easily eliminated;
- all kinds of waste water with concentrations in the range of 10–100 000 ppm can be treated by simply adapting the circulation ratio (more highly concentrated waste water requires a larger circulation ratio);
- fluidisation of pellets is also maintained if no waste water is fed into the reactor.

Achieved environmental benefits

Reduction of metals and metalloids, sulphate (SO_4^{2-}) and fluoride (F^-) in the waste water discharge.

Environmental performance and operational data

Crystallisation has been tested by three incineration plants in Denmark (Karanoveren, full-scale plant, 2006 (full-scale temporary plant, 2004); Esbjerg, full-scale, 2010; RenoNord, full-scale pilot test, 2008) to further reduce the concentration of metals after the chemical precipitation stage. [103, Denmark 2016]

The water to be treated is introduced into the reactor through a nozzle at the bottom. The chemicals are also injected at the bottom of the reactor. Inside the reactor, the granulated product is kept fluidised by the upflow stream of water to be treated and the recirculated water (see Figure 4.10). Iron or manganese is adsorbed on the granulate surface and, with oxidation agents, transformed into a granulate building material (FeOOH or MnO_2). At the same time, soluble metals are removed from the water and incorporated into the surface layer of FeOOH or MnO_2 . The process described has been tested for the removal of the cations Al, Ba, Cd, Co, Cr(III), Cu, Hg, Ni, Pb, Ra and Zn, as well as the anion-forming metalloids As, Cr^{VI} , Mo, Sb, Se(IV), U and V. The anion-forming metalloids in particular are often difficult to remove by conventional precipitation without producing a huge amount of sludge. [103, Denmark 2016]

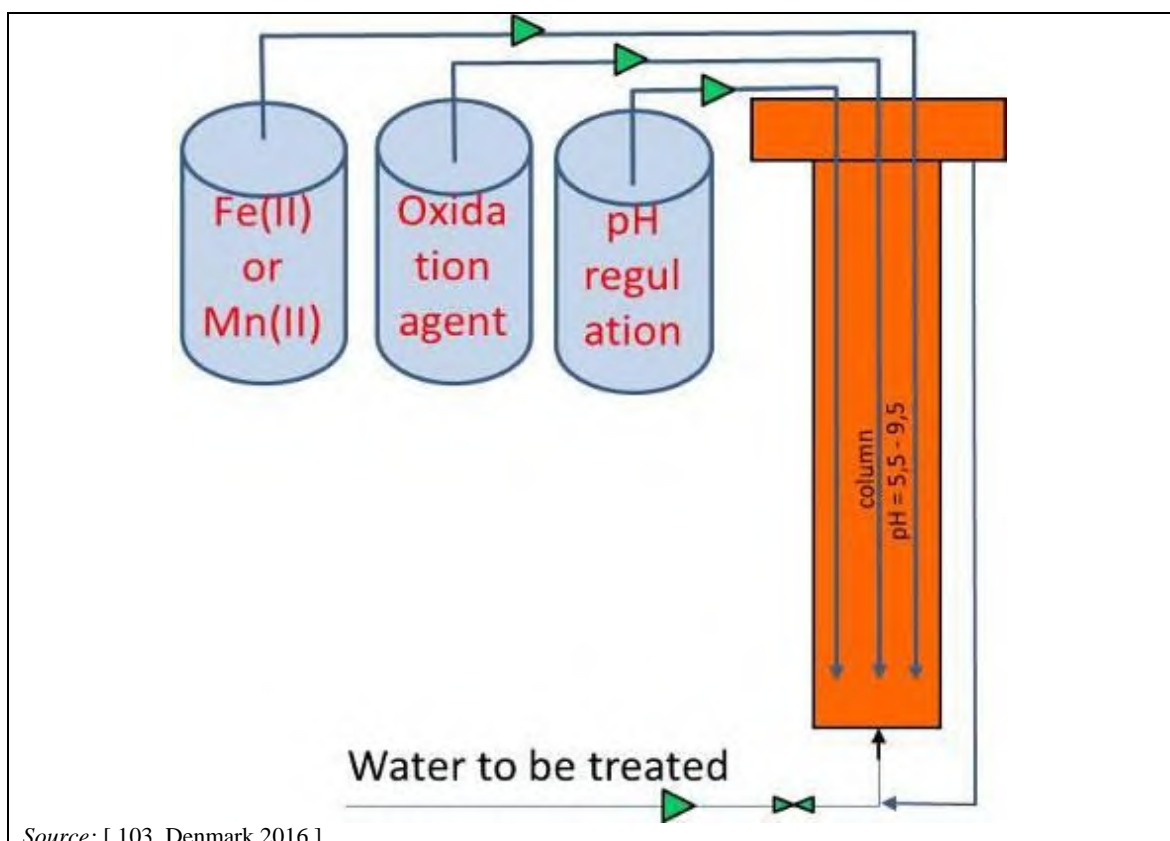

Figure 4.10: Flowsheet of crystallisation applied at three waste incineration plants in Denmark

Table 4.46 below shows the results of a testing period (April to August 2013) at the Esbjerg waste incineration plant in Denmark (L90 union of municipalities in Jutland) carried out to remove antimony and molybdenum that could not be removed in the chemical precipitation stage.

Table 4.46: Results of a testing period carried out to remove Mo and Sb at the Esbjerg incineration plant in Denmark

Sample date	Flow (m ³ /h)	Untreated water		Reagents used		Treated waste water			Capture rate	
		Mo	Sb	FeSO ₄	H ₂ O ₂	pH	Mo	Sb	Mo	Sb
		(µg/l)	(µg/l)	mg/l	mg/l		(µg/l)	(µg/l)	%	%
24/04/13	2.38	230.00	170.00	236	484	6.29	7.40	7.60	96.78	95.53
29/04/13	2.09	78.00	160.00	234	484	6.31	7.70	12.00	90.13	92.50
01/05/13	2.02	74.00	230.00	230	508	6.30	6.00	12.00	91.89	94.78
17/06/13	3.10	77.00	100.00	170	491	6.33	19.00	37.00	75.32	63.00
19/06/13	2.58	90.00	110.00	185	497	6.30	7.00	23.00	92.22	79.09
24/06/13	2.57	110.00	88.00	179	461	6.31	8.30	15.00	92.45	82.95
26/06/13	2.80	110.00	77.00	180	461	6.31	14.00	15.00	87.27	80.52
15/08/13	2.77	160.00	220.00	102	1185	6.46	25.00	16.00	84.38	92.73

Source: [103, Denmark 2016]

The crystallisation produces a solid residue in the form of a sandy granulate. The surface of this granulate consists of either FeOOH or MnO₂ plus the metals removed from the water. The content of metals is normally between 1 % and 8 % of the total weight of the dry granulate. The granulate is tapped from the bottom of the reactor while the plant is in operation, approximately a fiftieth of the total fluidised bed volume or approximately 10–20 l/week per 1 m³/h capacity. The granulate is easily drained. Tests conducted on this solid residue showed that it can be classified as non-hazardous waste. [103, Denmark 2016]

Cross-media effects

- Energy consumption.
- Residue handling and disposal.

Technical considerations relevant to applicability

The technique is generally applicable.

Economics

The investment cost is EUR 0.2 million to EUR 2 million depending on the size/capacity. The operating cost depends on the concentration and type of metals to be removed. It varies from EUR 0.01 to EUR 2 per m³ of treated waste water [103, Denmark 2016].

Driving force for implementation

Environmental legislation requirements.

Example plants

DE63, DE66, DK02, FR017.

Reference literature

[85, COM 2014], [103, Denmark 2016]

4.7 Treatment techniques for solid residues

The options for recovery and reuse of solid residues depend on:

- the content of organic compounds;
- the total content of heavy metals; the leachability of metals, salts and heavy metals;
- physical characteristics, e.g. particle size and strength.

In addition, market factors, regulations and policies concerning their use, and specific local environmental issues also impact greatly on the extent to which residues can be recovered.

Considerable efforts have been made to improve the environmental quality of residues and to recycle or reuse at least part of specific residue flows. Both in-process and downstream treatment techniques are applied. In-process measures involve changing the incineration parameters to improve burnout or to shift the metal distribution over the various residues. Downstream treatment techniques include: ageing, mechanical treatment, washing, thermal treatment and stabilisation. The various techniques are discussed below.

There are a number of principles which have to be considered when assessing the benefits but also the obstacles of a given treatment process:

- Does the process result in a significant quality improvement?
- Does the process cause any significant health, safety or environmental impacts?
- Are there secondary residues and where do they end up?
- Is there a final product of a high quality?
- Is there a long-term market for that product?
- What is the cost of the process?

Where legislation requires certain residues to be sent for disposal, there is less incentive for adopting techniques which would improve the quality and recyclability of the residues. [64, TWG 2003]

Figure 4.11 presents some mechanical treatment options for bottom ash. The combination of options that is used depends on the composition of the waste feed material and the end uses of the treated ash.

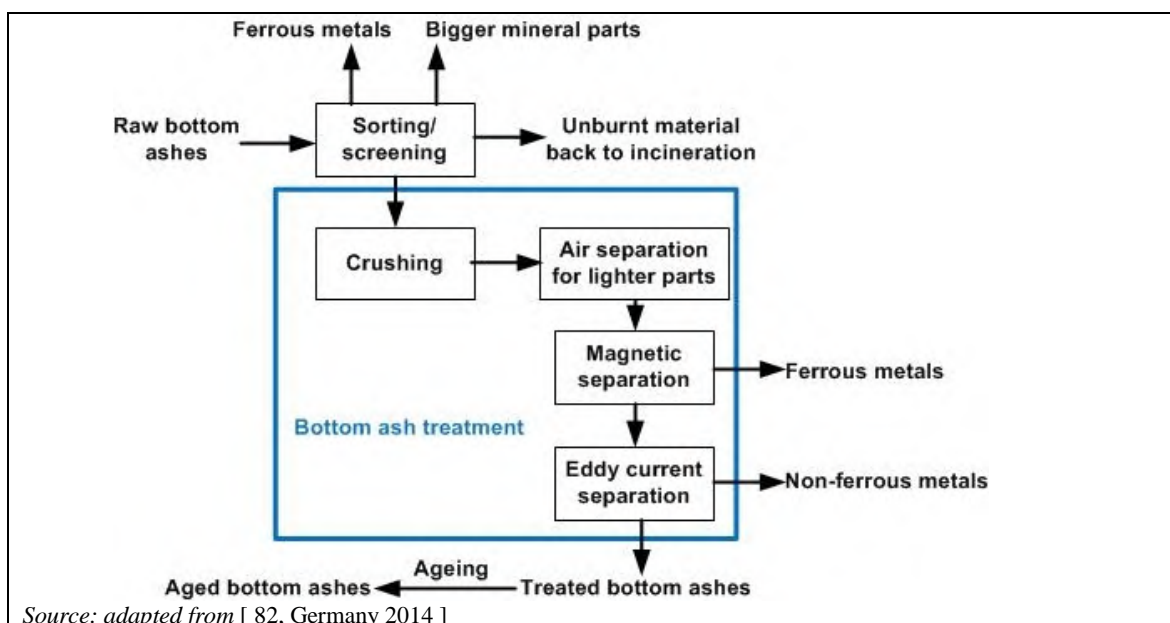

Figure 4.11: Flowsheet of an example IBA treatment process with some mechanical separation stages used for the treatment of bottom ash

4.7.1 Segregation of the bottom ash from flue-gas cleaning residues

Description

Bottom ash is handled and treated separately from the other residues produced from the incineration of waste.

Technical description

The physical and chemical properties of bottom ash mean that it is more suitable for beneficial use than FGC residues. Mixing FGC residues with bottom ash will limit the options for the subsequent use of the bottom ash and therefore should be avoided.

FGC residues have a higher metal content, metal leachability and organic content than bottom ash. Mixing FGC residues with bottom ash will reduce the environmental quality of the bottom ash and so should be avoided.

Segregation of the FGC residue from the bottom ash enables further treatment of the bottom ash (e.g. by dry treatment or by washing out the water-soluble salts, heavy metals in the ash extractor) to yield a material suitable for the intended use.

Segregation of bottom ash and FGC residues requires the separate collection, storage and transportation of both residue streams. This involves dedicated storage silos and containers, and specific handling systems for the fine and dusty FGC residue.

A mixed stream of bottom ash and FGC residue cannot be processed into a material suitable for recovery and leaves no other option for the whole residue stream but landfilling [74, TWG 2004], or use in underground applications such as mine backfilling.

Achieved environmental benefits

Reduced use of natural raw materials such as sand and gravel when the bottom ash, once treated, is recovered to be used as a replacement material. [74, TWG 2004]

Environmental performance and operational data

Separate transportation, storage and handling systems are required.

Cross-media effects

None reported.

Technical considerations relevant to applicability

This technique is generally applicable.

Economics

Cost reductions may be seen where bottom ash markets exist.

Bottom ash is typically 20–30 % by dry mass of the waste input and FGC residues are approximately 2–3 %. Mixing the two streams means sending all this material to landfill, whereas keeping them separate may allow the reuse of most of the bottom ashes (metals and mineral fraction) thus providing additional revenue streams and reducing landfill costs.

Driving force for implementation

- Increased possibilities for bottom ash recycling and possible cost reductions.
- Environmental legislation requirements.

Example plants

Widely adopted practice at incineration plants throughout Europe.

Reference literature

[64, TWG 2003]

4.7.2 Bottom ash screening/sieving and crushing

Description

Mechanical treatment operations intended to prepare materials for subsequent use, e.g. construction as a foundation material or road construction as a fill material.

Technical description

Mechanical treatment operations for bottom ash are intended to prepare materials for road and earthworks construction that possess satisfactory geotechnical characteristics and do not cause damage to the roadworks. The treatment operations that can be applied are:

- manual sorting;
- granulometric separation by screening/sieving;
- size reduction by crushing;
- removal of low-density unburned fractions by air separation.

Manual sorting is used to remove large components (e.g. non-ferrous metals, stainless steel and unburned items) from bottom ash before any subsequent treatment.

Manual sorting typically entails workers standing along a slow-moving conveyer belt holding the material to be sorted. [82, Germany 2014]

Several types of screen are encountered:

- rotary (or drum) screens;
- flat screens (vibrating or not);
- finger screens;
- star screens: screening is achieved by movement over a series of rollers equipped with star-shaped arms on each axis.

Primary screens used to prepare bottom ash aggregate typically have a mesh of 40 mm in diameter and produce an aggregate material of 0–40 mm size.

Half of the installations are equipped with a crusher to break up large chunks, which is usually located after the first screen. The benefits of using a crusher are:

- it reduces the amount of heavy rejects;
- it increases the proportion of rough crushed material in the material which give backbone to the aggregate; and
- it improves its geotechnical qualities.

Air separation is achieved by blowing or by aspiration. Air separation uses differences in density, particle size and particle shape to sort commingled materials. These characteristics often overlap and imply that the feedstock has to be prepared in such a way that a parameter for separating it is sufficiently clear. In addition, a narrow range of particle sizes is needed for effective separation. Using air separation also helps to improve the mineral fraction. [82, Germany 2014]

Achieved environmental benefits

The main environmental benefit of installing a mechanical treatment process is the reduction of the volume of rejects, and therefore a higher overall recovery rate in the preparation of materials for their recovery and subsequent use.

Environmental performance and operational data

No information provided.

Cross-media effects

- Energy consumption.
- Noise and dust emissions.

Technical considerations relevant to applicability

The technique is generally applicable, provided that there is a market for the treated bottom ash.

Economics

The cost-effectiveness of installing a system for breaking up heavy rejects depends on the quantities involved and the disposal costs that are avoided.

Driving force for implementation

The reasons for implementation are economic and regulatory.

Example plants

See Table 3.24.

Reference literature

[133, ADEME 2002]. [64, TWG 2003]

4.7.3 Separation of metals from bottom ash

Description

Ferrous metals are removed using magnetic separation and non-ferrous metals are removed using eddy current separation.

All-metal induction separation is sometimes also used.

Technical description

Both ferrous and non-ferrous metals may be extracted from bottom ash.

Ferrous metal separation is performed using a magnet. The ash is spread out on a moving belt or vibrating conveyor and all magnetic particles are attracted by a suspended magnet. This ferrous metals separation may be performed on the raw ash after it leaves the ash extractor. Efficient ferrous metals separation requires a multi-step treatment with intermediate size reduction and screening.

Non-ferrous metal separation is performed using an eddy current separator. A rapidly rotating coil induces a magnetic field in non-ferrous particles, which causes them to be ejected from the material flow. The technique requires the material to be well spread on the moving belt and is generally effective for particle sizes of 4–30 mm, although this range can be extended down to < 1 mm for special applications. The separation is performed after ferrous metal segregation, particle size reduction and screening.

All-metal separators usually detect metal particles by the perturbation they induce in the alternating magnetic field of a detection coil. The metal particles are then separated by one or more air jets located close to the detection coils. For further details see the BREF for Waste Treatment.

Larger fragments of both ferrous and non-ferrous metals may be removed by manual sorting before further treatment.

Achieved environmental benefits

The separation of metals is a necessary step to allow recycling of the various ash compounds. The ferrous fraction can be recycled, generally after separation of impurities (e.g. dust), as steel scrap for electric arc furnaces. The non-ferrous metals are processed externally by further separation according to metal type, and may then be melted down for reuse. After metal separation, the resulting ash fraction has a lower metal content and is more suitable for processing to yield an inert secondary construction material.

Environmental performance and operational data

The amount of recovered metals depends on the composition of the waste input. For ferrous metals, a recovery rate of approximately 80 % (mass of metal recovered/mass of metal input) is possible. [134, EdDE 2015]

For non-ferrous metals, using eddy current separation after size reduction and screening allows a 50 % recovery rate (mass recovered/mass input). The actual value is dependent on the metal and the operational conditions of the furnace. Non-ferrous metals, such as lead and zinc, are found in the boiler ash and the flue-gas cleaning residue. Aluminium, copper, chromium and nickel preferentially stay in the bottom ash. Oxidation of these metals (e.g. Al to Al_2O_3) during combustion will hamper the effective separation by eddy current separators. The separated non-ferrous fraction shows the following composition: 60 % Al, 25 % other metals, 15 % residue. The other metals are mainly copper, brass, zinc and stainless steel. [39, Vrancken 2001]

Specifications for the bottom ash to be recycled may include the total metals content. The most problematic metals from the point of view of leaching from the bottom ash are copper, molybdenum, zinc, and hexavalent chromium.

Cross-media effects

Increase in energy consumption.

Technical considerations relevant to applicability

Magnetic separation of ferrous metals is generally applicable.

The applicability of non-ferrous metal separation may be restricted by a lack of space or low throughput. The technique may be carried out off site at a dedicated bottom ash processing installation.

The applicability of the technique is strongly related to the metal content of the waste fed to the furnace. This, in turn, is highly influenced by the collection regime and pre-treatment that the waste has undergone before being fed to the furnace. For example, areas with extensive and well-performing segregation schemes for municipal wastes may remove significant quantities of metals from the furnace feed, making metal recovery from bottom ash less financially viable. Pre-treatment of MSW to create RDF will have a similar effect.

At some hazardous waste plants, shredded drums are removed using magnets prior to combustion.

Economics

The metal fractions can be sold to scrap dealers. Prices depend on the purity (ferrous) and composition (non-ferrous) of the material.

The market price for ferrous scrap is generally in the range of EUR 0.01–0.05 per kg.

Non-ferrous scrap needs further processing into pre-metal fractions. Prices for non-ferrous scrap depend on the amount of impurities (i.e. amount of processing needed) and the composition (i.e. price for final products). The content of copper and aluminium and the market price of secondary copper and aluminium are the main determining factors. The price of the non-ferrous fraction from MSW bottom ash treatment is in the range of EUR 0.10–1.00 per kg. [39, Vrancken 2001], [7, TWG 2017]

Driving force for implementation

The driving forces for implementation are economic:

- The revenue for the various fractions produced.
- After metal separation, the resulting ash fraction has a lower metal content and is more suitable for processing to yield a suitably inert secondary construction material. For example, residual non-ferrous metals may cause damage when bottom ash is reused in roadworks, due to swelling.

Example plants

Ferrous metal separation is performed in most European incinerators, either on site or at external bottom ash treatment plants. [74, TWG 2004]

Non-ferrous metal separation is performed at various bottom ash treatment plants in the Netherlands, Germany, France and Belgium.

Reference literature

[39, Vrancken 2001], [4, IAWG 1997], [64, TWG 2003], [74, TWG 2004]

4.7.4 Bottom ash treatment using ageing

Description

After metal separation, bottom ash from the incineration of non-hazardous waste is stored in the open air or in specific buildings to reduce both the residual reactivity and the leachability of the metals. Stockpiles are wetted and turned regularly to favour the leaching of salts and carbonation. CO₂ from the air and water from humidity, rain or water spraying are the main reactants.

Technical description

Carbonation (the reaction between CO₂ and hydroxides in the alkaline bottom ash) is one of the key reactions in the ageing of bottom ash. The purpose of the ageing therefore is to reduce the remaining reactivity and to improve the technical properties. The leaching of bottom ash reduces after ageing, especially the leaching of metals such as Cu, Cr, Pb and Zn. [89, COM 2015]

The storage is generally performed in stockpiles on a concrete or other impermeable floor. The stockpiles may be wetted, if required, using a sprinkler or hose system in order to prevent dust formation and emissions and to favour the leaching of salts and carbonation if the bottom ashes are not sufficiently wet. The leaching and drain water is collected and sent to a waste water treatment plant or used to humidify the stockpiles if the leachate quality is suitable.

The stockpiles may be turned regularly to ensure the homogeneity of the processes that occur during the ageing process (uptake of CO₂ from the air due to the moisture, draining of excess water, oxidation, etc.) and to reduce the residence time of every batch of bottom ash in the dedicated facilities.

In practice, an ageing period of 6 to 20 weeks is commonly observed (or prescribed) for treated bottom ash before utilisation as a construction material or in some cases before landfilling [74, TWG 2004]. The time necessary for the ageing process varies depending on factors such as stockpile size, ambient temperature, initial moisture content and infiltration of rainwater.

In some cases, the entire process is performed inside a closed building. This assists with dust, odour, noise (from machinery and vehicles) and leachate control. In other cases, the process is totally or partially performed outdoors. This generally allows more space to easily handle bottom ash, and can give more air circulation for bottom ash to mature, [64, TWG 2003] and

may avoid the release of explosive hydrogen in combination with aluminium during the ageing process. [74, TWG 2004] Aluminium in the bottom ash will react with $\text{Ca}(\text{OH})_2$ and water to form aluminium hydroxide and hydrogen gas, causing a volume increase and swelling of the material, which would cause technical problems if fresh bottom ash were used in construction without ageing.

Achieved environmental benefits

Increased resource efficiency where bottom ash substitutes raw materials.

Environmental performance and operational data

The impact of ageing on leaching can be classified as:

- lowering of the pH due to uptake of CO_2 from the air or the biological activity;
- establishing of anoxic, reducing conditions due to the biodegradation of residual organic matter or to hydrogen evolution;
- particle cohesion and other changes in mineral phases due to the hydration.

[4, IAWG 1997]

All these effects reduce the leachability of metals and cause the stabilisation of the bottom ash. This makes the bottom ash more suited for recovery or disposal (landfilling). [74, TWG 2004]

Data from a test programme in a full-scale German waste incineration plant illustrate the effect of 12 weeks of ageing on the pH of bottom ashes and on the test results obtained by the DEV S4 method. The left-hand side of Figure 4.12 shows that the pH of the fresh bottom ashes in the DEV S4 test typically exceeds 12 and drops by about two units during the ageing process.

As can be seen on the right of Figure 4.12, this pH change has no effect on the leaching properties of molybdenum, which is present mainly as molybdate. The leaching stability of copper and zinc is moderately improved in the aged material whereas the leaching of lead is reduced by almost two orders of magnitude.

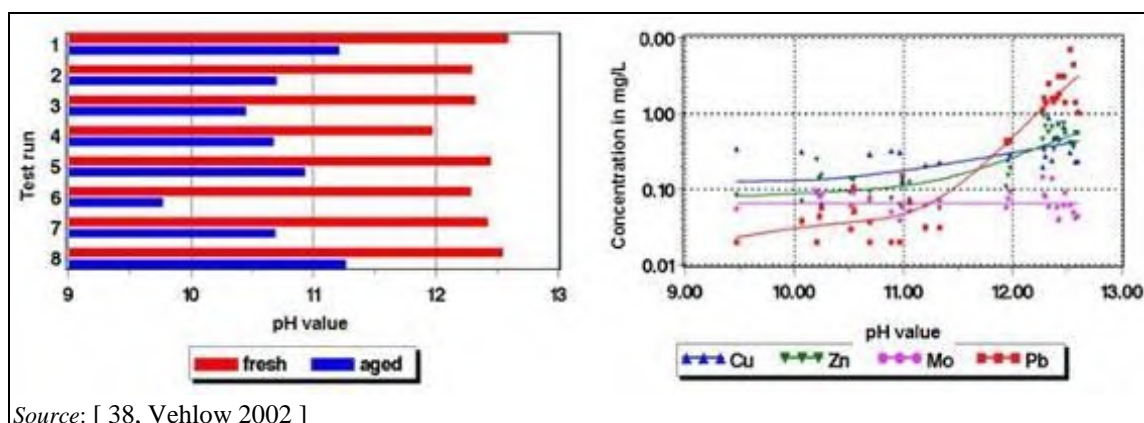

Source: [38, Vehlow 2002]

Figure 4.12: Effect of ageing on the leachability of selected metals: (left) effect on pH; (right) leaching as a function of pH

The French Bureau of Mines conducted a study over 18 months on the ageing (and its effect on leaching) of a 400-tonne stockpile of bottom ashes and reached similar conclusions to this German study. [64, TWG 2003]

If longer ageing periods (e.g. > 20 weeks) are used for ferrous-metal-free bottom ash without turning, the aged bottom ash will become increasingly solidified. [74, TWG 2004]

Cross-media effects

- Run-off water from rain or sprinkling may contain salts or metals and need treatment. The water can be recirculated or used in the incinerator as process water.
- Odour and dust controls may be required.
- Vehicle and machinery noise may be an issue in some locations.
- Anti-explosive devices at indoor ageing facilities may be required. [74, TWG 2004]

Technical considerations relevant to applicability

The technique is generally applicable.

Economics

The cost of ageing is low compared to the rest of the treatment installation. [74, TWG 2004]

Savings are made in disposal costs by recycling. [74, TWG 2004]

Driving force for implementation

Legislation providing leaching limit values for recycling of bottom ash as a secondary raw material or for landfilling. [74, TWG 2004]

Example plants

Various bottom ash treatment plants in the Netherlands, Germany, France and Belgium.

Reference literature

[38, Vehlow 2002], [4, IAWG 1997], [64, TWG 2003]

4.7.5 Bottom ash treatment using dry treatment systems

Description

Dry bottom ash treatment combines the techniques of metal separation, size reduction and screening, and may be combined with ageing of the treated bottom ash. The product is a dry aggregate with a controlled grain size (e.g. 0–4 mm, 0–10 mm, 4–10 mm), which may be used as a secondary construction material.

Technical description

The process consists of:

- crushing of the coarse fraction;
- sieving;
- ferrous metal separation;
- non-ferrous metal separation;
- ageing.

[74, TWG 2004]

Achieved environmental benefits

The technique produces a dry aggregate that may be used as a secondary construction material and scrap metal fractions that can be sold for recycling, thus reducing the amount of residue sent for disposal.

Environmental performance and operational data

Post-treatment bottom ash quality data are shown in the tables below, for an installation using the following process steps :

- raw bottom ash kept in dry storage for 4–6 weeks;
- preliminary sieving of particles > 150 mm;
- removal of ferrous metals from < 150 mm fraction;
- further sieve separation (< 22 mm, 22–32 mm, > 32 mm);
- < 22 mm fraction marketed as sand substitute;
- > 32 mm fraction sent to hand picking and separators to remove non-incinerable and ferrous fractions, crushing and recirculation;
- 22–32 mm fraction undergoes air separation of light fractions and ferrous metal removal;
- separated metal fractions undergo sieving, cleaning and storage before completely passing through the process again separately from the slag.

Table 4.47: Bottom ash output concentration data reported for an example bottom ash treatment facility

	Output bottom ash content (mg/kg)
As	150
Cd	10
Cr	600
Cu	600
Pb	1 000
Ni	600
Zn	1
Hg	0.01
<i>Source: [64, TWG 2003]</i>	

Table 4.48: Bottom ash output eluate data reported for an example bottom ash treatment

	Output bottom ash eluate data (µg/l)
As	
Cd	5
Cr	200
Cu	300
Pb	50
Ni	40
Zn	300
Hg	1
<i>Source: [64, TWG 2003]</i>	

Another example of an IBA treatment process is the following (carried out by a Danish plant):

- screening of IBA to produce two size fractions: above and below 50 mm;
- removal of ferrous metal using a magnet;
- removal of non-ferrous metal using an eddy current separator;
- the > 50 mm residue is hand-sorted and crushed;
- combustible material is returned to the incinerator as feedstock.

The plant capacity is 80 tonnes of bottom ashes per hour (equivalent to 350 tonnes of waste incinerated per hour). The plant uses diesel as an energy source, consuming 0.3 l per tonne of bottom ashes processed (equivalent to 0.05 l per tonne of waste incinerated). The plant recovers 90 wt-% of the metals present in the bottom ashes, which represent 8 wt-% of the treated bottom ashes. [104, Denmark 2015]

Cross-media effects

Dust and noise emissions.

Technical considerations relevant to applicability

The technique is generally applicable.

Economics

In order to be economically viable, a minimum throughput is needed. For small waste incineration plants, an external (centralised) bottom ash treatment may be used.

The main benefit is derived from avoiding disposal costs; apart from that, the economy of the bottom ash treatment operation depends on the market price of the fractions produced. Treated bottom ash will generally be sold, transportation included, at zero cost. Revenue is created by the quality of the non-ferrous and ferrous metal fractions. Non-ferrous metals such as copper and aluminium are the products with the highest market value. The amount and purity of the non-ferrous metals produced are important factors in the overall economics of the installation.

Data from a MSWI plant in Sweden using various dry ash treatment stages and ageing

- The tax for landfilling the ash is approximately EUR 40/t.
- The stone and gravel which is separated at the earlier stages of the treatment process has a commercial value of around EUR 6/t.
- The commercial value of the treated bottom ash residue as a construction material is around EUR 2.5/t.

Driving force for implementation

Legislation on recycling of residues as secondary raw materials.

Example plants

Several sites in Denmark, the Netherlands, Germany, Belgium and France.

Reference literature

[4, IAWG 1997], [39, Vrancken 2001], [64, TWG 2003], [104, Denmark 2015]

4.7.6 Bottom ash treatment using wet treatment systems

Description

The use of a wet bottom ash treatment system allows the production of a material for recycling with substantially reduced leachability of metals and anions (e.g. salts). The incineration ashes are treated by size reduction, sieving, washing and metal separation. The main feature of the treatment is the wet separation of a 0–2 mm fraction.

Technical description

Wet bottom ash treatment aims to remove metals, in order to reduce both the metal content and metal leaching. Other constituents of concern are soluble salts, mainly alkali and earth-alkali chlorides and sulphates. Approximately 50 % of the chloride content can be reduced by washing the ashes.

Usually the wet treatment system is made up of a dry step where the bottom ashes generated by the incineration of waste are treated to remove the large ferrous metals and dry crushed to reach the size required by the wet process.

After this first step, the IBA is washed and separated into different fractions with water using a rotating drum or a jigger. The separated lightweight part mainly formed of unburned materials, plastic and paper is usually returned to the incineration.

A granulated fraction is treated to remove the ferrous and non-ferrous metals and the remaining washed mineral part can be recovered.

The fine fraction contains most of the contaminants and is disposed of.

An example of a bottom ash wet treatment process is shown in Figure 4.13.

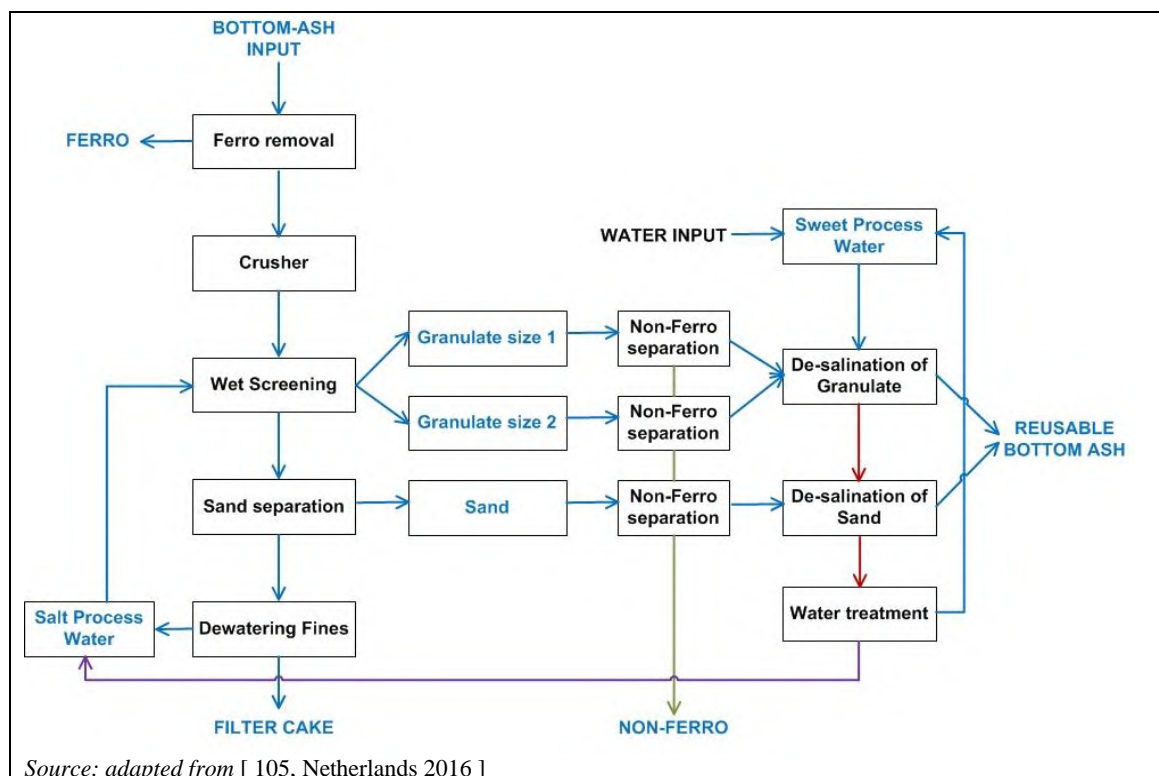

Figure 4.13: Flow diagram of a bottom ash wet treatment system

Achieved environmental benefits

The technique produces a material that is suitable for use and reduces the amount of residue for disposal.

Environmental performance and operational data

The relative yield of the various fractions depends on the waste input composition. Operational data from a working installation are given in Table 4.49.

Table 4.49: Relative yield of various output fractions of wet bottom ash treatment

Residue type	Mass % (output/bottom ash input)
Residue for disposal (0–2 mm)	47
Product for reuse (2–60 mm)	34
Ferrous metals	12
Non-ferrous metals	2
Unburnt output returned to incinerator	5

Source: [39, Vrancken 2001]

Table 4.50 below shows an example of the leaching results of the produced granulates.

Table 4.50: Example of leaching results of the produced granulates

	Leaching value (mg/kg)	
	2–6 mm granulates	6–50 mm granulates
As	0–0.1	< 0.05
Cd	0–0.025	< 0.01
Cr	0.005–0.053	< 0.053
Cu	0.19–0.85	0.24–0.55
Pb	0.04–0.12	< 0.10
Ni	0.0007–0.005	< 0.057
Zn	0.61–1.27	< 0.16
NB: Data from column leaching test NEN7343 Ratio L/S=10 (cumulative) Source: [64, TWG 2003], [74, TWG 2004]		

Other post-treatment bottom ash quality data are shown in Table 4.51 and Table 4.52 below for an installation using the following techniques:

- water washing of bottom ash in the bottom ash discharger at the furnace exit (water reduces the salt levels in the bottom ash);
- removal of ferrous and large particles by sieving and manual separation;
- storage for > 1 day for CO₂ reaction (ageing);
- further sieving, breaking, separation (e.g. > 32 mm fraction separate milling);
- ferrous and non-ferrous metals removal;
- > 10 mm fraction is recirculated after air separation of the light (e.g. plastic) fraction;
- storage of the product for 3 months.

Table 4.51: Bottom ash output concentration (mg/kg) data reported for an example bottom ash treatment facility

	Output bottom ash content (mg/kg)	
	Range	Average
As	25–187	74
Cd	1.1–16.7	3.7
Cr	84–726	172
Cu	1 676–29 781	6 826
Pb	404–4 063	1 222
Ni	61–661	165
Zn	788–14 356	2 970
Hg	0.01–0.37	0.7
Source: [64, TWG 2003]		

Table 4.52: Bottom ash eluate ($\mu\text{g/l}$) data reported for an example bottom ash treatment facility

	Output bottom ash eluate data ($\mu\text{g/l}$)	
	Range	Average
As	< 6.0–16.1	5.3
Cd	< 0.5–2.5	0.8
Cr	1–113	15.2
Cu	14–262	60.7
Pb	8–59	11.4
Ni	< 4.0–11.6	2.9
Zn	< 5.0–230	19.4
Hg	< 0.2–< 0.2	< 0.2
<i>Source:</i> [64, TWG 2003]		

A plant in the Netherlands uses the following wet treatment process:

- Dry removal of large ferrous metal objects using magnets, screening of IBA to remove large pieces, crushing of large pieces to smaller than 20 mm, removal of small ferrous metal objects using magnets.
- Separation into different fractions with water using a rotating drum sieve. After this separation, the main fractions are IBA sand (0–4 mm) and IBA granulate (4–20 mm).
- The IBA sand fraction is pumped into hydrocyclones to separate the fine fraction (< 0.063 mm). After this separation by weight, the next treatment step is separation by density. The sand is processed in a rising water column, where fines and organic parts are separated, and collected in the same tank with the fines from the hydrocyclone separation. The IBA sand is dewatered on a screen then passed over an eddy current separator to remove the non-ferrous metals. It is then quenched in a dewatering screw to remove the final adherent salt water and small fines. The quench tank is fed with fresh water, with a liquid to solid ratio of at least 1 m³ per tonne to remove all the remaining contaminants. The IBA sand is then dewatered with a dewatering screen and can be stored ready for use or combined with the IBA granulate.
- The IBA granulate fraction is treated in a log washer, where the scrubbing treatment removes the organic fraction and all the fines that stick to the surface of the mineral fraction. The fines and organic fraction are collected together with the fine fraction from the IBA sand treatment.
The IBA granulate is dewatered to separate it from the salt water, then passed over an eddy current separator to remove the non-ferrous metals. It is then washed with fresh water in a dewatering screen to remove the last adherent salts and fines. The liquid to solid ratio of the fresh water is at least 1 m³ per tonne. The IBA granulate is then dewatered with a dewatering screen and can be stored ready for use or combined with the IBA sand.
- The fine fraction (0–0.063 mm) (IBA sludge) consists of both organic material and very fine mineral particles and contains a high concentration of contaminants. The fine fraction is treated with flocculants and separated from the water stream in a pre-thickener. The sludge is dewatered in a belt press or a chamber filter press and sent for disposal to landfill.

Another example of a wet process, in an Austrian plant, is given below:

The initial treatment steps are: screening of IBA and/or FBA to remove large pieces (> 55 mm) and long pieces such as pipes and cables; removal of large ferrous metal objects from both fractions (> 55 mm and < 55 mm) using overhead conveyor magnets; crushing of the < 55 mm fraction is an option that can be used to increase the metal recovery rate in the subsequent wet treatment stage.

The wet treatment process uses a jigger to separate the < 55 mm IBA/FBA into four fractions of different densities:

- **Floating materials (paper, plastics and lightweight minerals):** this fraction is dewatered and either transported back to the incinerator as feedstock or landfilled.
- **Heavy fraction (metals and minerals with a density > 4 kg/dm³):** this fraction is a mixture of different metals (copper, brass, stainless steel, zinc, tin, precious metals) and minerals. This fraction is washed, concentrated and transported to a copper smelter.
- **Light fraction (metals and minerals with a density < 4 kg/dm³):** this fraction is a mixture of minerals (ash, stones and concrete), aluminium and traces of some other metals. This fraction is fed into a drum magnet to separate ferrous metals then an eddy current separator to remove non-ferrous metals such as aluminium and stainless steel. The aluminium concentrate can be used in an aluminium smelter or scrap treatment plant. The remaining mineral fraction can be landfilled, used as a building material in road construction or as an aggregate in concrete provided it meets the relevant product standards and regulation.
- **Sludge:** The sludge from the jigger is dewatered using a centrifuge and mixed with the mineral fraction. The further use of the dewatered material in road construction is possible.

Cross-media effects

The wet treatment can result in the production of a fine fraction (0–2 mm) for disposal. Additionally, a waste water fraction is produced. This waste water may be fed back into the incinerator as process water, if the quality is compatible with the process. [74, TWG 2004]

Technical considerations relevant to applicability

The technique is generally applicable.

The applicability may be limited when ambient temperatures are below 5 °C unless precautions are taken to prevent the water from freezing. [107, Austria 2015]

Economics

In order to be economically viable, a certain minimum throughput is needed. For small waste incineration plants, an external (centralised) bottom ash treatment is often used. The economics of the bottom ash treatment operation depend on the market price of the fractions produced. Treated bottom ash will generally be sold at zero cost. Revenue is created by the quality of the non-ferrous and ferrous metal fractions. Non-ferrous metals such as copper and aluminium are the products with the highest market value. The amount and purity of the non-ferrous metals produced are important factors in the overall economics of the installation.

For an Austrian plant treating 40 t/day of bottom ash:

- the capital cost is EUR 2 million, which is equivalent to a capital cost of EUR 5–10 per tonne of ash processed;
- the operating cost is EUR 5–10 per tonne;
- the total cost is EUR 10–20 per tonne of ash processed.

Driving force for implementation

Legislation for recycling of residues as secondary raw materials.

Example plants

AT.B-01, BE.B-02, HVC Groep, Dordrecht MWI line 5 (NL).

Reference literature

[38, Vehlow 2002], [39, Vrancken 2001], [4, IAWG 1997], [64, TWG 2003], [105, Netherlands 2016], [107, Austria 2015]

4.7.7 Techniques to reduce emissions to air from the treatment of incineration slags and bottom ashes

Description

The techniques to consider are:

- humidify the stockpiles and the main sources of diffuse dust emissions;
- limit the height of discharge;
- protect the stockpiles against prevailing winds;
- operate in closed building;
- enclose equipment such as the shredder, sieve, conveyor belts, wind sifter, air-aeraulic separator;
- keep such equipment under subatmospheric pressure;
- treat the extracted air with a bag filter.

Technical description

Emissions to air from bottom ash treatment plants are mainly dust and metals coming from bottom ash handling, shredding, sieving, and air separation.

Using techniques that keep the bottom ashes' water content around 20 % reduces the diffuse emissions of dust. This involves maintaining an optimal moisture content, which on the one hand allows the efficient recovery of metals and mineral materials and on the other hand keeps the dust releases low.

Water spray systems can be installed at the main sources of diffuse dust emissions. Diffuse dust emissions at stockpiles are reduced by ensuring appropriate humidification of the charging and discharging points, or of the stockpiles themselves.

Dust releases are also minimised by matching the discharge height to the varying height of the bottom ash heap (e.g. through conveyor belts with adjustable heights), and by protecting bulk storage areas and stockpiles with covers or wind barriers such as screening, walling or vertical greenery.

In order to avoid the release of diffuse emissions into the environment, the storage and treatment of bottom ashes can also be performed in closed buildings.

Enclosed equipment working under subatmospheric pressure is used in order to prevent emissions to air. The extracted air is sent to a bag filter. In order to reduce the bag filter dust load, in some cases a cyclone is used as a first dedusting step.

Achieved environmental benefits

- Reduction of diffuse emissions.
- Reduction of dust emissions.

Environmental performance and operational data

Table 3.29 shows the dust emission levels of some EU plants with the techniques applied to reduce emissions to air and the emission sources.

Cross-media effects

Increase in water and energy use.

Technical considerations relevant to applicability

Operation under subatmospheric pressure with filtration of the extracted air is only applicable to dry-discharged and other low-moisture bottom ashes.

The other techniques described are generally applicable.

Economics

No information provided.

Driving force for implementation

Environmental and health regulation requirements.

Example plants

CZ B-01, DE B-05, DE.B-10, DE.B-11, IT.B-01, IT.B-02

Reference literature

[81, TWG 2016], [126, EIPPCB 2017]

4.7.8 Waste water treatment

Waste water comes mainly from the wet process, washing processes, storage areas, and contaminated rainwater where slags and bottom ashes are stored outside.

Process waste water contains salts and metals as well as suspended solids and organic substances including PCDD/F.

Techniques to consider for the treatment of waste water from the IBA treatment plants are:

- oil separation;
- neutralisation;
- sedimentation;
- chemical precipitation;
- filtration.

These techniques are described in Section 3.3.2.3 of the CWW BREF.

Table 3.30 summarises the levels of emissions to water reported through the 2016 data collection.

4.8 Noise

The noise aspects of waste incineration are comparable with other industries and with power generation plants. It is common for municipal waste incineration plants to be installed in completely closed buildings. This normally includes reception and unloading of waste, mechanical pre-treatment, flue-gas treatment, treatment of residues, etc. The only activities that are normally located outside the building are the cooling facilities and the long-term storage of bottom ash. Bottom ash treatment may take place in closed buildings or in the open air.

The most important sources of external noise are:

- trucks for the transport of waste, chemicals and residues;
- crane operations in the bunker;
- mechanical pre-treatment of waste;
- exhaust fans, extracting flue-gases from the incineration process and resulting in noise from the outlet of the stack;
- noise related to the cooling system (for evaporation cooling and especially for air cooling);
- noise related to transport and treatment of bottom ash;
- noise from the turbo-generator set.

[74, TWG 2004]

The other activities do not usually produce significant external noise but may contribute to the general external noise produced by the installation.

The main sources of noise, the noise levels they give rise to and some specific noise abatement techniques are given in Table 3.38.

The degree of noise protection and measures taken are often very specific to the location and risk of impacts.

5 BEST AVAILABLE TECHNIQUES (BAT) CONCLUSIONS FOR WASTE INCINERATION

Scope

These BAT conclusions concern the following activities specified in Annex I to Directive 2010/75/EU:

- 5.2 Disposal or recovery of waste in waste incineration plants:
 - (a) for non-hazardous waste with a capacity exceeding 3 tonnes per hour;
 - (b) for hazardous waste with a capacity exceeding 10 tonnes per day.
- 5.2 Disposal or recovery of waste in waste co-incineration plants:
 - (a) for non-hazardous waste with a capacity exceeding 3 tonnes per hour;
 - (b) for hazardous waste with a capacity exceeding 10 tonnes per day;
 whose main purpose is not the production of material products and where at least one of the following conditions is fulfilled:
 - only waste, other than waste defined in Article 3(31)(b) of Directive 2010/75/EU is combusted;
 - more than 40 % of the resulting heat release comes from hazardous waste;
 - mixed municipal waste is combusted.
- 5.3 (a) Disposal of non-hazardous waste with a capacity exceeding 50 tonnes per day involving the treatment of slags and/or bottom ashes from the incineration of waste.
- 5.3 (b) Recovery, or a mix of recovery and disposal, of non-hazardous waste with a capacity exceeding 75 tonnes per day involving the treatment of slags and/or bottom ashes from the incineration of waste.
- 5.1 Disposal or recovery of hazardous waste with a capacity exceeding 10 tonnes per day involving the treatment of slags and/or bottom ashes from the incineration of waste.

These BAT conclusions do not address the following:

- Pre-treatment of waste prior to incineration. This may be covered by the BAT conclusions for Waste Treatment (WT).
- Treatment of incineration fly ashes and other residues resulting from flue-gas cleaning (FGC). This may be covered by the BAT conclusions for Waste Treatment (WT).
- Incineration or co-incineration of exclusively gaseous waste other than that resulting from the thermal treatment of waste.
- Treatment of waste in plants covered by Article 42(2) of Directive 2010/75/EU.

Other BAT conclusions and reference documents which could be relevant for the activities covered by these BAT conclusions are the following:

- Waste Treatment (WT);
- Economics and Cross-Media Effects (ECM);
- Emissions from Storage (EFS);
- Energy Efficiency (ENE);
- Industrial Cooling Systems (ICS);
- Monitoring of Emissions to Air and Water from IED Installations (ROM);
- Large Combustion Plants (LCP);
- Common Waste Water and Waste Gas Treatment/Management Systems in the Chemical Sector (CWW).

Definitions

For the purposes of these BAT conclusions, the following general **definitions** apply:

Term	Definition
General terms	
Boiler efficiency	Ratio between the energy produced at the boiler output (e.g. steam, hot water) and the waste's and auxiliary fuel's energy input to the furnace (as lower heating values).
Bottom ash treatment plant	Plant treating slags and/or bottom ashes from the incineration of waste in order to separate and recover the valuable fraction and to allow the beneficial use of the remaining fraction. This does not include the sole separation of coarse metals at the incineration plant.
Clinical waste	Infectious or otherwise hazardous waste arising from healthcare institutions (e.g. hospitals).
Channelled emissions	Emissions of pollutants into the environment through any kind of duct, pipe, stack, chimney, funnel, flue, etc.
Continuous measurement	Measurement using an automated measuring system permanently installed on site.
Diffuse emissions	Non-channelled emissions (e.g. of dust, volatile compounds, odour) into the environment, which can result from 'area' sources (e.g. tankers) or 'point' sources (e.g. pipe flanges).
Existing plant	A plant that is not a new plant.
Fly ashes	Particles from the combustion chamber or formed within the flue-gas stream that are transported in the flue-gas.
Hazardous waste	Hazardous waste as defined in Article 3(2) of Directive 2008/98/EC.
Incineration of waste	The combustion of waste, either alone or in combination with fuels, in an incineration plant.
Incineration plant	Either a waste incineration plant as defined in Article 3(40) of Directive 2010/75/EU or a waste co-incineration plant as defined in Article 3(41) of Directive 2010/75/EU, covered by the scope of these BAT conclusions.
Major plant upgrade	A major change in the design or technology of a plant with major adjustments or replacements of the process and/or abatement technique(s) and associated equipment.
Municipal solid waste	Solid waste from households (mixed or separately collected) as well as solid waste from other sources that is comparable to household waste in nature and composition.
New plant	A plant first permitted following the publication of these BAT conclusions or a complete replacement of a plant following the publication of these BAT conclusions.
Other non-hazardous waste	Non-hazardous waste that is neither municipal solid waste nor sewage sludge.
Part of an incineration plant	For the purposes of determining the gross electrical efficiency or the gross energy efficiency of an incineration plant, a part of it may refer for example to: <ul style="list-style-type: none"> • an incineration line and its steam system in isolation; • a part of the steam system, connected to one or more boilers, routed to a condensing turbine; • the rest of the same steam system that is used for a different purpose, e.g. the steam is directly exported.
Periodic measurement	Measurement at specified time intervals using manual or automated methods.
Residues	Any liquid or solid waste which is generated by an incineration plant or by a bottom ash treatment plant.
Sensitive receptor	Area which needs special protection, such as: <ul style="list-style-type: none"> • residential areas; • areas where human activities are carried out (e.g. neighbouring workplaces, schools, daycare centres, recreational areas, hospitals or nursing homes).

Sewage sludge	Residual sludge from the storage, handling and treatment of domestic, urban or industrial waste water. For the purposes of these BAT conclusions, residual sludges constituting hazardous waste are excluded.
Slags and/or bottom ashes	Solid residues removed from the furnace once wastes have been incinerated.
Valid half-hourly average	A half-hourly average is considered valid when there is no maintenance or malfunction of the automated measuring system.

Term	Definition
Pollutants and parameters	
As	The sum of arsenic and its compounds, expressed as As.
Cd	The sum of cadmium and its compounds, expressed as Cd.
Cd+Tl	The sum of cadmium, thallium and their compounds, expressed as Cd+Tl.
CO	Carbon monoxide.
Cr	The sum of chromium and its compounds, expressed as Cr.
Cu	The sum of copper and its compounds, expressed as Cu.
Dioxin-like PCBs	PCBs showing a similar toxicity to the 2,3,7,8-substituted PCDD/PCDF according to the World Health Organization (WHO).
Dust	Total particulate matter (in air).
HCl	Hydrogen chloride.
HF	Hydrogen fluoride.
Hg	The sum of mercury and its compounds, expressed as Hg.
Loss on ignition	Change in mass as a result of heating a sample under specified conditions.
N ₂ O	Dinitrogen monoxide (nitrous oxide).
NH ₃	Ammonia.
NH ₄ -N	Ammonium nitrogen, expressed as N, includes free ammonia (NH ₃) and ammonium (NH ₄ ⁺).
Ni	The sum of nickel and its compounds, expressed as Ni.
NO _x	The sum of nitrogen monoxide (NO) and nitrogen dioxide (NO ₂), expressed as NO ₂ .
Pb	The sum of lead and its compounds, expressed as Pb.
PBDD/F	Polybrominated dibenzo- <i>p</i> -dioxins and -furans.
PCBs	Polychlorinated biphenyls.
PCDD/F	Polychlorinated dibenzo- <i>p</i> -dioxins and -furans.
POPs	Persistent Organic Pollutants as listed in Annex IV to Regulation (EC) No 850/2004 of the European Parliament and of the Council and its amendments.
Sb	The sum of antimony and its compounds, expressed as Sb.
Sb+As+Pb+Cr+Co+Cu+Mn+Ni+V	The sum of antimony, arsenic, lead, chromium, cobalt, copper, manganese, nickel, vanadium and their compounds, expressed as Sb+As+Pb+Cr+Co+Cu+Mn+Ni+V.
SO ₂	Sulphur dioxide.
Sulphate (SO ₄ ²⁻)	Dissolved sulphate, expressed as SO ₄ ²⁻ .
TOC	Total organic carbon, expressed as C (in water); includes all organic compounds.
TOC content (in solid residues)	Total organic carbon content. The quantity of carbon that is converted into carbon dioxide by combustion and which is not liberated as carbon dioxide by acid treatment.
TSS	Total suspended solids. Mass concentration of all suspended solids (in water), measured via filtration through glass fibre filters and gravimetry.
Tl	The sum of thallium and its compounds, expressed as Tl.
TVOC	Total volatile organic carbon, expressed as C (in air).
Zn	The sum of zinc and its compounds, expressed as Zn.

Acronyms

For the purposes of these BAT conclusions, the following **acronyms** apply:

Acronym	Definition
EMS	Environmental management system
FDBR	Fachverband Anlagenbau (from the previous name of the organisation: Fachverband Dampfkessel-, Behälter- und Rohrleitungsbau)
FGC	Flue-gas cleaning
OTNOC	Other than normal operating conditions
SCR	Selective catalytic reduction
SNCR	Selective non-catalytic reduction
I-TEQ	International toxic equivalent according to the North Atlantic Treaty Organization (NATO) schemes
WHO-TEQ	Toxic equivalent according to the World Health Organization (WHO) schemes

General considerations

Best Available Techniques

The techniques listed and described in these BAT conclusions are neither prescriptive nor exhaustive. Other techniques may be used that ensure at least an equivalent level of environmental protection.

Unless otherwise stated, these BAT conclusions are generally applicable.

Emission levels associated with the best available techniques (BAT-AELs) for emissions to air

Emission levels associated with the best available techniques (BAT-AELs) for emissions to air given in these BAT conclusions refer to concentrations, expressed as mass of emitted substances per volume of flue-gas or of extracted air under the following standard conditions: dry gas at a temperature of 273.15 K and a pressure of 101.3 kPa, and expressed in mg/Nm³, µg/Nm³, ng I-TEQ/Nm³ or ng WHO-TEQ/Nm³.

The reference oxygen levels used to express BAT-AELs in this document are shown in the table below.

Activity	Reference oxygen level (OR)
Incineration of waste	11 dry vol-%
Bottom ash treatment	No correction for the oxygen level

The equation for calculating the emission concentration at the reference oxygen level is:

$$E_R = \frac{21 - O_R}{21 - O_M} \times E_M$$

Where:

- E_R : emission concentration at the reference oxygen level O_R ;
- O_R : reference oxygen level in vol-%;
- E_M : measured emission concentration;
- O_M : measured oxygen level in vol-%.

For averaging periods, the following **definitions** apply:

Type of measurement	Averaging period	Definition
Continuous	Half-hourly average	Average value over a period of 30 minutes
	Daily average	Average over a period of one day based on valid half-hourly averages
Periodic	Average over the sampling period	Average value of three consecutive measurements of at least 30 minutes each ⁽¹⁾
	Long-term sampling period	Value over a sampling period of 2 to 4 weeks

⁽¹⁾ For any parameter where, due to sampling or analytical limitations, 30-minute sampling/measurement and/or an average of three consecutive measurements is inappropriate, a more suitable procedure may be employed. For PCDD/F and dioxin-like PCBs, one sampling period of 6 to 8 hours is used in the case of short-term sampling.

When waste is co-incinerated together with non-waste fuels, the BAT-AELs for emissions to air given in these BAT conclusions apply to the entire flue-gas volume generated.

Emission levels associated with the best available techniques (BAT-AELs) for emissions to water

Emission levels associated with the best available techniques (BAT-AELs) for emissions to water given in these BAT conclusions refer to concentrations (mass of emitted substances per volume of waste water), expressed in mg/l or ng I-TEQ/l.

For waste water from FGC, the BAT-AELs refer either to spot sampling (for TSS only) or to daily averages, i.e. 24-hour flow-proportional composite samples. Time-proportional composite sampling can be used provided that sufficient flow stability is demonstrated.

For waste water from bottom ash treatment, the BAT-AELs refer to either of the following two cases:

- in the case of continuous discharges, daily average values, i.e. 24-hour flow-proportional composite samples;
- in the case of batch discharges, average values over the release duration taken as flow-proportional composite samples, or, provided that the effluent is appropriately mixed and homogeneous, a spot sample taken before discharge.

The BAT-AELs for emissions to water apply at the point where the emission leaves the installation.

Energy efficiency levels associated with the best available techniques (BAT-AEELs)

The BAT-AEELs given in these BAT conclusions for the incineration of non-hazardous waste other than sewage sludge and of hazardous wood waste are expressed as:

- gross electrical efficiency in the case of an incineration plant or part of an incineration plant that produces electricity using a condensing turbine;
- gross energy efficiency in the case of an incineration plant or part of an incineration plant that:
 - produces only heat, or
 - produces electricity using a back-pressure turbine and heat with the steam leaving the turbine.

This is expressed as follows:

Gross electrical efficiency	$\eta_e = \frac{W_e}{Q_{th}} \times (Q_b / (Q_b - Q_i))$
Gross energy efficiency	$\eta_h = \frac{W_e + Q_{he} + Q_{de} + Q_i}{Q_{th}}$

Where:

- W_e : electrical power generated, in MW;
- Q_{he} : thermal power supplied to the heat exchangers on the primary side, in MW;
- Q_{de} : directly exported thermal power (as steam or hot water) less the thermal power of the return flow, in MW;
- Q_b : thermal power produced by the boiler, in MW;
- Q_i : thermal power (as steam or hot water) that is used internally (e.g. for flue-gas reheating), in MW;
- Q_{th} : thermal input to the thermal treatment units (e.g. furnaces), including the waste and auxiliary fuels that are used continuously (excluding for example for start-up), in MW_{th} expressed as the lower heating value.

The BAT-AEELs given in these BAT conclusions for the incineration of sewage sludge and of hazardous waste other than hazardous wood waste are expressed as boiler efficiency.

BAT-AEELs are expressed as a percentage.

The monitoring associated with the BAT-AEELs is given in BAT 2.

Content of unburnt substances in bottom ashes/slugs

The content of unburnt substances in the slags and/or bottom ashes is expressed as a percentage of the dry weight, either as the loss on ignition or as the TOC mass fraction.

5.1 BAT conclusions

5.1.1 Environmental management systems

BAT 1. In order to improve the overall environmental performance, BAT is to elaborate and implement an environmental management system (EMS) that incorporates all of the following features:

- i. commitment, leadership and accountability of the management, including senior management, for the implementation of an effective EMS;
- ii. an analysis that includes the determination of the organisation's context, the identification of the needs and expectations of interested parties, the identification of characteristics of the installation that are associated with possible risks for the environment (or human health) as well as of the applicable legal requirements relating to the environment;
- iii. development of an environmental policy that includes the continuous improvement of the environmental performance of the installation;
- iv. establishing objectives and performance indicators in relation to significant environmental aspects, including safeguarding compliance with applicable legal requirements;
- v. planning and implementing the necessary procedures and actions (including corrective and preventive actions where needed), to achieve the environmental objectives and avoid environmental risks;
- vi. determination of structures, roles and responsibilities in relation to environmental aspects and objectives and provision of the financial and human resources needed;
- vii. ensuring the necessary competence and awareness of staff whose work may affect the environmental performance of the installation (e.g. by providing information and training);
- viii. internal and external communication;
- ix. fostering employee involvement in good environmental management practices;
- x. establishing and maintaining a management manual and written procedures to control activities with significant environmental impact as well as relevant records;
- xi. effective operational planning and process control;
- xii. implementation of appropriate maintenance programmes;
- xiii. emergency preparedness and response protocols, including the prevention and/or mitigation of the adverse (environmental) impacts of emergency situations;
- xiv. when (re)designing a (new) installation or a part thereof, consideration of its environmental impacts throughout its life, which includes construction, maintenance, operation and decommissioning;
- xv. implementation of a monitoring and measurement programme; if necessary, information can be found in the Reference Report on Monitoring of Emissions to Air and Water from IED Installations;
- xvi. application of sectoral benchmarking on a regular basis;
- xvii. periodic independent (as far as practicable) internal auditing and periodic independent external auditing in order to assess the environmental performance and to determine whether or not the EMS conforms to planned arrangements and has been properly implemented and maintained;
- xviii. evaluation of causes of nonconformities, implementation of corrective actions in response to nonconformities, review of the effectiveness of corrective actions, and determination of whether similar nonconformities exist or could potentially occur;
- xix. periodic review, by senior management, of the EMS and its continuing suitability, adequacy and effectiveness;
- xx. following and taking into account the development of cleaner techniques.

Specifically for incineration plants and, where relevant, bottom ash treatment plants, BAT is also to incorporate the following features in the EMS:

- xxi. for incineration plants, waste stream management (see BAT 9);
- xxii. for bottom ash treatment plants, output quality management (see BAT 10);
- xxiii. a residues management plan including measures aiming to:
 - a. minimise the generation of residues;
 - b. optimise the reuse, regeneration, recycling of, and/or energy recovery from the residues;
 - c. ensure the proper disposal of residues;
- xxiv. for incineration plants, an OTNOC management plan (see BAT 18);
- xxv. for incineration plants, an accident management plan (see Section 5.2.4);
- xxvi. for bottom ash treatment plants, diffuse dust emissions management (see BAT 23);
- xxvii. an odour management plan where an odour nuisance at sensitive receptors is expected and/or has been substantiated (see Section 5.2.4);
- xxviii. a noise management plan (see also BAT 37) where a noise nuisance at sensitive receptors is expected and/or has been substantiated (see Section 5.2.4).

Note

Regulation (EC) No 1221/2009 establishes the European Union eco-management and audit scheme (EMAS), which is an example of an EMS consistent with this BAT.

Applicability

The level of detail and the degree of formalisation of the EMS will generally be related to the nature, scale and complexity of the installation, and the range of environmental impacts it may have (determined also by the type and the amount of waste processed).

5.1.2 Monitoring

BAT 2. BAT is to determine either the gross electrical efficiency, the gross energy efficiency, or the boiler efficiency of the incineration plant as a whole or of all the relevant parts of the incineration plant.

Description

In the case of a new incineration plant or after each modification of an existing incineration plant that could significantly affect the energy efficiency, the gross electrical efficiency, the gross energy efficiency, or the boiler efficiency is determined by carrying out a performance test at full load.

In the case of an existing incineration plant that has not carried out a performance test, or where a performance test at full load cannot be carried out for technical reasons, the gross electrical efficiency, the gross energy efficiency, or the boiler efficiency can be determined taking into account the design values at performance test conditions.

For the performance test, no EN standard is available for the determination of the boiler efficiency of incineration plants. For grate-fired incineration plants, the FDBR guideline RL 7 may be used.

BAT 3. BAT is to monitor key process parameters relevant for emissions to air and water including those given below.

Stream/Location	Parameter(s)	Monitoring
Flue-gas from the incineration of waste	Flow, oxygen content, temperature, pressure, water vapour content	Continuous measurement
Combustion chamber	Temperature	
Waste water from wet FGC	Flow, pH, temperature	
Waste water from bottom ash treatment plants	Flow, pH, conductivity	

BAT 4. BAT is to monitor channelled emissions to air with at least the frequency given below and in accordance with EN standards. If EN standards are not available, BAT is to use ISO, national or other international standards that ensure the provision of data of an equivalent scientific quality.

Substance/Parameter	Process	Standard(s) ⁽¹⁾	Minimum monitoring frequency ⁽²⁾	Monitoring associated with
NO _x	Incineration of waste	Generic EN standards	Continuous	BAT 29
NH ₃	Incineration of waste when SNCR and/or SCR is used	Generic EN standards	Continuous	BAT 29
N ₂ O	<ul style="list-style-type: none"> Incineration of waste in fluidised bed furnace Incineration of waste when SNCR is operated with urea 	EN 21258 ⁽³⁾	Once every year	BAT 29
CO	Incineration of waste	Generic EN standards	Continuous	BAT 29
SO ₂	Incineration of waste	Generic EN standards	Continuous	BAT 27
HCl	Incineration of waste	Generic EN standards	Continuous	BAT 27
HF	Incineration of waste	Generic EN standards	Continuous ⁽⁴⁾	BAT 27
Dust	Bottom ash treatment	EN 13284-1	Once every year	BAT 26
	Incineration of waste	Generic EN standards and EN 13284-2	Continuous	BAT 25
Metals and metalloids except mercury (As, Cd, Co, Cr, Cu, Mn, Ni, Pb, Sb, Tl, V)	Incineration of waste	EN 14385	Once every six months	BAT 25
Hg	Incineration of waste	Generic EN standards and EN 14884	Continuous ⁽⁵⁾	BAT 31
TVOC	Incineration of waste	Generic EN standards	Continuous	BAT 30
PBDD/F	Incineration of waste ⁽⁶⁾	No EN standard available	Once every six months	BAT 30

PCDD/F	Incineration of waste	EN 1948-1, EN 1948-2, EN 1948-3	Once every six months for short-term sampling	BAT 30
		No EN standard available for long-term sampling, EN 1948-2, EN 1948-3	Once every month for long-term sampling ⁽⁷⁾	BAT 30
Dioxin-like PCBs	Incineration of waste	EN 1948-1, EN 1948-2, EN 1948-4	Once every six months for short-term sampling ⁽⁸⁾	BAT 30
		No EN standard available for long-term sampling, EN 1948-2, EN 1948-4	Once every month for long-term sampling ⁽⁷⁾⁽⁸⁾	BAT 30
Benzo[a]pyrene	Incineration of waste	No EN standard available	Once every year	BAT 30

⁽¹⁾ Generic EN standards for continuous measurements are EN 15267-1, EN 15267-2, EN 15267-3 and EN 14181. EN standards for periodic measurements are given in the table or in the footnotes.

⁽²⁾ For periodic monitoring, the monitoring frequency does not apply where plant operation would be for the sole purpose of performing an emission measurement.

⁽³⁾ If continuous monitoring of N₂O is applied, the generic EN standards for continuous measurements apply.

⁽⁴⁾ The continuous measurement of HF may be replaced by periodic measurements with a minimum frequency of once every six months if the HCl emission levels are proven to be sufficiently stable. No EN standard is available for the periodic measurement of HF.

⁽⁵⁾ For plants incinerating wastes with a proven low and stable mercury content (e.g. mono-streams of waste of a controlled composition), the continuous monitoring of emissions may be replaced by long-term sampling (no EN standard is available for long-term sampling of Hg or periodic measurements with a minimum frequency of once every six months. In the latter case the relevant standard is EN 13211.

⁽⁶⁾ The monitoring only applies to the incineration of waste containing brominated flame retardants or to plants using BAT 31 d with continuous injection of bromine.

⁽⁷⁾ The monitoring does not apply if the emission levels are proven to be sufficiently stable.

⁽⁸⁾ The monitoring does not apply where the emissions of dioxin-like PCBs are proven to be less than 0.01 ng WHO-TEQ/Nm³.

BAT 5. BAT is to appropriately monitor channelled emissions to air from the incineration plant during OTNOC.

Description

The monitoring can be carried out by direct emission measurements (e.g. for the pollutants that are monitored continuously) or by monitoring of surrogate parameters if this proves to be of equivalent or better scientific quality than direct emission measurements. Emissions during start-up and shutdown while no waste is being incinerated, including emissions of PCDD/F, are estimated based on measurement campaigns, e.g. every three years, carried out during planned start-up/shutdown operations.

BAT 6. BAT is to monitor emissions to water from FGC and/or bottom ash treatment with at least the frequency given below and in accordance with EN standards. If EN standards are not available, BAT is to use ISO, national or other international standards that ensure the provision of data of an equivalent scientific quality.

Substance/Parameter	Process	Standard(s)	Minimum monitoring frequency	Monitoring associated with
Total organic carbon (TOC)	FGC	EN 1484	Once every month	BAT 34
	Bottom ash treatment		Once every month ⁽¹⁾	
Total suspended solids (TSS)	FGC	EN 872	Once every day ⁽²⁾	
	Bottom ash treatment		Once every month ⁽¹⁾	
As	FGC	Various EN standards available (e.g. EN ISO 11885, EN ISO 15586 or EN ISO 17294-2)	Once every month	
Cd	FGC			
Cr	FGC			
Cu	FGC			
Mo	FGC			
Ni	FGC			
Pb	FGC		Once every month	
	Bottom ash treatment		Once every month ⁽¹⁾	
Sb	FGC		Once every month	
Tl	FGC			
Zn	FGC			
Hg	FGC	Various EN standards available (e.g. EN ISO 12846 or EN ISO 17852)	Once every month	
Ammonium-nitrogen (NH ₄ -N)	Bottom ash treatment	Various EN standards available (e.g. EN ISO 11732, EN ISO 14911)	Once every month ⁽¹⁾	
Chloride (Cl ⁻)	Bottom ash treatment	Various EN standards available (e.g. EN ISO 10304-1, EN ISO 15682)		
Sulphate (SO ₄ ²⁻)	Bottom ash treatment	EN ISO 10304-1		
PCDD/F	FGC	No EN standard available	Once every month ⁽¹⁾	
	Bottom ash treatment		Once every six months	

⁽¹⁾ The monitoring frequency may be at least once every six months if the emissions are proven to be sufficiently stable.

⁽²⁾ The daily 24-hour flow-proportional composite sampling measurements may be substituted by daily spot sample measurements.

BAT 7. BAT is to monitor the content of unburnt substances in slags and bottom ashes at the incineration plant with at least the frequency given below and in accordance with EN standards.

Parameter	Standard(s)	Minimum monitoring frequency	Monitoring associated with
Loss on ignition ⁽¹⁾	EN 14899 and either EN 15169 or EN 15935	Once every three months	BAT 14
Total organic carbon ⁽¹⁾ ⁽²⁾	EN 14899 and either EN 13137 or EN 15936		
⁽¹⁾ Either the loss on ignition or the total organic carbon is monitored.			
⁽²⁾ Elemental carbon (e.g. determined according to DIN 19539) may be subtracted from the measurement result.			

BAT 8. For the incineration of hazardous waste containing POPs, BAT is to determine the POP content in the output streams (e.g. slags and bottom ashes, flue-gas, waste water) after the commissioning of the incineration plant and after each change that may significantly affect the POP content in the output streams.

Description

The POP content in the output streams is determined by direct measurements or by indirect methods (e.g. the cumulated quantity of POPs in the fly ashes, dry FGC residues, waste water from FGC and related waste water treatment sludge may be determined by monitoring the POP contents in the flue-gas before and after the FGC system) or based on studies representative of the plant.

Applicability

Only applicable for plants that:

- incinerate hazardous waste with POP levels prior to incineration exceeding the concentration limits defined in Annex IV to Regulation (EC) No 850/2004 and amendments; and
- do not meet the process description specifications of Chapter IV.G.2 point (g) of the UNEP technical guidelines UNEP/CHW.13/6/Add.1/Rev.1.

5.1.3 General environmental and combustion performance

BAT 9. In order to improve the overall environmental performance of the incineration plant by waste stream management (see BAT 1), BAT is to use all of the techniques (a) to (c) given below, and, where relevant, also techniques (d), (e) and (f).

	Technique	Description
a.	Determination of the types of waste that can be incinerated	Based on the characteristics of the incineration plant, identification of the types of waste which can be incinerated in terms of, for example, the physical state, the chemical characteristics, the hazardous properties, and the acceptable ranges of calorific value, humidity, ash content and size.
b.	Set-up and implementation of waste characterisation and pre-acceptance procedures	These procedures aim to ensure the technical (and legal) suitability of waste treatment operations for a particular waste prior to the arrival of the waste at the plant. They include procedures to collect information about the waste input and may include waste sampling and characterisation to achieve sufficient knowledge of the waste composition. Waste pre-acceptance procedures are risk-based considering, for example, the hazardous properties of the waste, the risks posed by the waste in terms of process safety, occupational safety and environmental impact, as well as the information provided by the previous waste holder(s).
c.	Set-up and implementation of waste acceptance procedures	Acceptance procedures aim to confirm the characteristics of the waste, as identified at the pre-acceptance stage. These procedures define the elements to be verified upon the delivery of the waste at the plant as well as the waste acceptance and rejection criteria. They may include waste sampling, inspection and analysis. Waste acceptance procedures are risk-based considering, for example, the hazardous properties of the waste, the risks posed by the waste in terms of process safety, occupational safety and environmental impact, as well as the information provided by the previous waste holder(s). The elements to be monitored for each type of waste are detailed in BAT 11.
d.	Set-up and implementation of a waste tracking system and inventory	A waste tracking system and inventory aims to track the location and quantity of waste in the plant. It holds all the information generated during waste pre-acceptance procedures (e.g. date of arrival at the plant and unique reference number of the waste, information on the previous waste holder(s), pre-acceptance and acceptance analysis results, nature and quantity of waste held on site including all identified hazards), acceptance, storage, treatment and/or transfer off site. The waste tracking system is risk-based considering, for example, the hazardous properties of the waste, the risks posed by the waste in terms of process safety, occupational safety and environmental impact, as well as the information provided by the previous waste holder(s). The waste tracking system includes clear labelling of wastes that are stored in places other than the waste bunker or sludge storage tank (e.g. in containers, drums, bales or other forms of packaging) such that they can be identified at all times.
e.	Waste segregation	Wastes are kept separated depending on their properties in order to enable easier and environmentally safer storage and incineration. Waste segregation relies on the physical separation of different wastes and on procedures that identify when and where wastes are stored.
f.	Verification of waste compatibility prior to the mixing or blending of hazardous wastes	Compatibility is ensured by a set of verification measures and tests in order to detect any unwanted and/or potentially dangerous chemical reactions between wastes (e.g. polymerisation, gas evolution, exothermal reaction, decomposition) upon mixing or blending. The compatibility tests are risk-based considering, for example, the hazardous properties of the waste, the risks posed by the waste in terms of process safety, occupational safety and environmental impact, as well as the information provided by the previous waste holder(s).

BAT 10. In order to improve the overall environmental performance of the bottom ash treatment plant, BAT is to include output quality management features in the EMS (see BAT 1).

Description

Output quality management features are included in the EMS, so as to ensure that the output of the bottom ash treatment is in line with expectations, using existing EN standards where available. This also allows the performance of the bottom ash treatment to be monitored and optimised.

BAT 11. In order to improve the overall environmental performance of the incineration plant, BAT is to monitor the waste deliveries as part of the waste acceptance procedures (see BAT 9 c) including, depending on the risk posed by the incoming waste, the elements given below.

Waste type	Waste delivery monitoring
Municipal solid waste and other non-hazardous waste	<ul style="list-style-type: none"> • Radioactivity detection • Weighing of the waste deliveries • Visual inspection • Periodic sampling of waste deliveries and analysis of key properties/substances (e.g. calorific value, content of halogens and metals/metalloids). For municipal solid waste, this involves separate unloading.
Sewage sludge	<ul style="list-style-type: none"> • Weighing of the waste deliveries (or measuring the flow if the sewage sludge is delivered via pipeline) • Visual inspection, as far as technically possible • Periodic sampling and analysis of key properties/substances (e.g. calorific value, content of water, ash and mercury)
Hazardous waste other than clinical waste	<ul style="list-style-type: none"> • Radioactivity detection • Weighing of the waste deliveries • Visual inspection, as far as technically possible • Control and comparison of individual waste deliveries with the declaration of the waste producer • Sampling of the content of: <ul style="list-style-type: none"> ○ all bulk tankers and trailers ○ packed waste (e.g. in drums, intermediate bulk containers (IBCs) or smaller packaging) and analysis of: <ul style="list-style-type: none"> ○ combustion parameters (including calorific value and flashpoint) ○ waste compatibility, to detect possible hazardous reactions upon blending or mixing wastes, prior to storage (BAT 9 f) ○ key substances including POPs, halogens and sulphur, metals/metalloids
Clinical waste	<ul style="list-style-type: none"> • Radioactivity detection • Weighing of the waste deliveries • Visual inspection of the packaging integrity

BAT 12. In order to reduce the environmental risks associated with the reception, handling and storage of waste, BAT is to use both of the techniques given below.

	Technique	Description
a.	Impermeable surfaces with an adequate drainage infrastructure	Depending on the risks posed by the waste in terms of soil or water contamination, the surface of the waste reception, handling and storage areas is made impermeable to the liquids concerned and fitted with an adequate drainage infrastructure (see BAT 32). The integrity of this surface is periodically verified, as far as technically possible.
b.	Adequate waste storage capacity	Measures are taken to avoid accumulation of waste, such as: <ul style="list-style-type: none"> • the maximum waste storage capacity is clearly established and not exceeded, taking into account the characteristics of the wastes (e.g. regarding the risk of fire) and the treatment capacity; • the quantity of waste stored is regularly monitored against the maximum allowed storage capacity; • for wastes that are not mixed during storage (e.g. clinical waste, packed waste), the maximum residence time is clearly established.

BAT 13. In order to reduce the environmental risk associated with the storage and handling of clinical waste, BAT is to use a combination of the techniques given below.

	Technique	Description
a.	Automated or semi-automated waste handling	Clinical wastes are unloaded from the truck to the storage area using an automated or manual system depending on the risk posed by this operation. From the storage area the clinical wastes are fed into the furnace by an automated feeding system.
b.	Incineration of non-reusable sealed containers, if used	Clinical waste is delivered in sealed and robust combustible containers that are never opened throughout storage and handling operations. If needles and sharps are disposed of in them, the containers are puncture-proof as well.
c.	Cleaning and disinfection of reusable containers, if used	Reusable waste containers are cleaned in a designated cleaning area and disinfected in a facility specifically designed for disinfection. Any leftovers from the cleaning operations are incinerated.

BAT 14. In order to improve the overall environmental performance of the incineration of waste, to reduce the content of unburnt substances in slags and bottom ashes, and to reduce emissions to air from the incineration of waste, BAT is to use an appropriate combination of the techniques given below.

	Technique	Description	Applicability
a.	Waste blending and mixing	Waste blending and mixing prior to incineration includes for example the following operations: <ul style="list-style-type: none"> • bunker crane mixing; • using a feed equalisation system; • blending of compatible liquid and pasty wastes. In some cases, solid wastes are shredded prior to mixing.	Not applicable where direct furnace feeding is required due to safety considerations or waste characteristics (e.g. infectious clinical waste, odorous wastes, or wastes that are prone to releasing volatile substances). Not applicable where undesired reactions may occur between different types of waste (see BAT 9 f).
b.	Advanced control system	See Section 5.2.1	Generally applicable.
c.	Optimisation of the incineration process	See Section 5.2.1	Optimisation of the design is not applicable to existing furnaces.

Table 5.1: BAT-associated environmental performance levels for unburnt substances in slags and bottom ashes from the incineration of waste

Parameter	Unit	BAT-AEPL
TOC content in slags and bottom ashes ⁽¹⁾	Dry wt-%	1–3 ⁽²⁾
Loss on ignition of slags and bottom ashes ⁽¹⁾	Dry wt-%	1–5 ⁽²⁾
⁽¹⁾ Either the BAT-AEPL for TOC content or the BAT-AEPL for the loss on ignition applies.		
⁽²⁾ The lower end of the BAT-AEPL range can be achieved when using fluidised bed furnaces or rotary kilns operated in slagging mode.		

The associated monitoring is in BAT 7.

BAT 15. In order to improve the overall environmental performance of the incineration plant and to reduce emissions to air, BAT is to set up and implement procedures for the adjustment of the plant's settings, e.g. through the advanced control system (see description in Section 5.2.1), as and when needed and practicable, based on the characterisation and control of the waste (see BAT 11).

BAT 16. In order to improve the overall environmental performance of the incineration plant and to reduce emissions to air, BAT is to set up and implement operational procedures (e.g. organisation of the supply chain, continuous rather than batch operation) to limit as far as practicable shutdown and start-up operations.

BAT 17. In order to reduce emissions to air and, where relevant, to water from the incineration plant, BAT is to ensure that the FGC system and the waste water treatment plant are appropriately designed (e.g. considering the maximum flow rate and pollutant concentrations), operated within their design range, and maintained so as to ensure optimal availability.

BAT 18. In order to reduce the frequency of the occurrence of OTNOC and to reduce emissions to air and, where relevant, to water from the incineration plant during OTNOC, BAT is to set up and implement a risk-based OTNOC management plan as part of the environmental management system (see BAT 1) that includes all of the following elements:

- identification of potential OTNOC (e.g. failure of equipment critical to the protection of the environment ('critical equipment')), of their root causes and of their potential consequences, and regular review and update of the list of identified OTNOC following the periodic assessment below;
- appropriate design of critical equipment (e.g. compartmentalisation of the bag filter, techniques to heat up the flue-gas and obviate the need to bypass the bag filter during start-up and shutdown, etc.);
- set-up and implementation of a preventive maintenance plan for critical equipment (see BAT 1 xii);
- monitoring and recording of emissions during OTNOC and associated circumstances (see BAT 5);
- periodic assessment of the emissions occurring during OTNOC (e.g. frequency of events, duration, amount of pollutants emitted) and implementation of corrective actions if necessary.

5.1.4 Energy efficiency

BAT 19. In order to increase the resource efficiency of the incineration plant, BAT is to use a heat recovery boiler.

Description

The energy contained in the flue-gas is recovered in a heat recovery boiler producing hot water and/or steam, which may be exported, used internally, and/or used to produce electricity.

Applicability

In the case of plants dedicated to the incineration of hazardous waste, the applicability may be limited by:

- the stickiness of the fly ashes;
- the corrosiveness of the flue-gas.

BAT 20. In order to increase the energy efficiency of the incineration plant, BAT is to use an appropriate combination of the techniques given below.

	Technique	Description	Applicability
a.	Drying of sewage sludge	After mechanical dewatering, sewage sludge is further dried, using for example low-grade heat, before it is fed to the furnace. The extent to which sludge can be dried depends on the furnace feeding system.	Applicable within the constraints associated with the availability of low-grade heat.
b.	Reduction of the flue-gas flow	The flue-gas flow is reduced through, e.g.: <ul style="list-style-type: none"> improving the primary and secondary combustion air distribution; flue-gas recirculation (see Section 5.2.2) A smaller flue-gas flow reduces the energy demand of the plant (e.g. for induced draught fans).	For existing plants, the applicability of flue-gas recirculation may be limited due to technical constraints (e.g. pollutant load in the flue-gas, incineration conditions).
c.	Minimisation of heat losses	Heat losses are minimised through, e.g.: <ul style="list-style-type: none"> use of integral furnace-boilers, allowing for heat to also be recovered from the furnace sides; thermal insulation of furnaces and boilers; flue-gas recirculation (see Section 5.2.2); recovery of heat from the cooling of slags and bottom ashes (see BAT 20 i). 	Integral furnace-boilers are not applicable to rotary kilns or to other furnaces dedicated to the high-temperature incineration of hazardous waste.
d.	Optimisation of the boiler design	The heat transfer in the boiler is improved by optimising, for example, the: <ul style="list-style-type: none"> flue-gas velocity and distribution; water/steam circulation; convection bundles; on-line and off-line boiler cleaning systems in order to minimise the fouling of the convection bundles. 	Applicable to new plants and to major retrofits of existing plants.
e.	Low-temperature flue-gas heat exchangers	Special corrosion-resistant heat exchangers are used to recover additional energy from the flue-gas at the boiler exit, after an ESP, or after a dry sorbent injection system	Applicable within the constraints of the operating temperature profile of the FGC system. In the case of existing plants, the applicability may be limited by a lack of space.

f.	High steam conditions	<p>The higher the steam conditions (temperature and pressure), the higher the electricity conversion efficiency allowed by the steam cycle.</p> <p>Working at high steam conditions (e.g. above 45 bar, 400 °C) requires the use of special steel alloys or refractory cladding to protect the boiler sections that are exposed to the highest temperatures.</p>	<p>Applicable to new plants and to major retrofits of existing plants, where the plant is mainly oriented towards the generation of electricity.</p> <p>The applicability may be limited by:</p> <ul style="list-style-type: none"> • the stickiness of the fly ashes; • the corrosiveness of the flue-gas.
g.	Cogeneration	<p>Cogeneration of heat and electricity where the heat (mainly from the steam that leaves the turbine) is used for producing hot water/steam to be used in industrial processes/activities or in a district heating/cooling network.</p>	<p>Applicable within the constraints associated with the local heat and power demand and/or availability of networks.</p>
h.	Flue-gas condenser	<p>A heat exchanger or a scrubber with a heat exchanger, where the water vapour contained in the flue-gas condenses, transferring the latent heat to water at a sufficiently low temperature (e.g. return flow of a district heating network).</p> <p>The flue-gas condenser also provides co-benefits by reducing emissions to air (e.g. of dust and acid gases).</p> <p>The use of heat pumps can increase the amount of energy recovered from flue-gas condensation.</p>	<p>Applicable within the constraints associated with the demand for low-temperature heat, e.g. by the availability of a district heating network with a sufficiently low return temperature.</p>
i.	Dry bottom ash handling	<p>Dry, hot bottom ash falls from the grate onto a transport system and is cooled down by ambient air. Useful energy is recovered by using the cooling air for combustion</p>	<p>Only applicable to grate furnaces.</p> <p>There may be technical restrictions that prevent retrofitting to existing furnaces.</p>

Table 5.2: BAT-associated energy efficiency levels (BAT-AEELs) for the incineration of waste

BAT-AEEL (%)				
Plant	Municipal solid waste, other non-hazardous waste and hazardous wood waste		Hazardous waste other than hazardous wood waste ⁽¹⁾	Sewage sludge
	Gross electrical efficiency ⁽²⁾ ⁽³⁾	Gross energy efficiency ⁽⁴⁾	Boiler efficiency	
New plant	25–35	72–91 ⁽⁵⁾	60–80	60–70 ⁽⁶⁾
Existing plant	20–35			

⁽¹⁾ The BAT-AEEL only applies where a heat recovery boiler is applicable.

⁽²⁾ The BAT-AEELs for gross electrical efficiency only apply to plants or parts of plants producing electricity using a condensing turbine.

⁽³⁾ The higher end of the BAT-AEEL range can be achieved when using BAT 20 f.

⁽⁴⁾ The BAT-AEELs for gross energy efficiency only apply to plants or parts of plants producing only heat or producing electricity using a back-pressure turbine and heat with the steam leaving the turbine.

⁽⁵⁾ A gross energy efficiency exceeding the higher end of the BAT-AEEL range (even above 100 %) can be achieved where a flue-gas condenser is used.

⁽⁶⁾ For the incineration of sewage sludge, the boiler efficiency is highly dependent on the water content of the sewage sludge as fed into the furnace.

The associated monitoring is in BAT 2.

5.1.5 Emissions to air

5.1.5.1 Diffuse emissions

BAT 21. In order to prevent or reduce diffuse emissions from the incineration plant, including odour emissions, BAT is to:

- store solid and bulk pasty wastes that are odorous and/or prone to releasing volatile substances in enclosed buildings under controlled subatmospheric pressure and use the extracted air as combustion air for incineration or send it to another suitable abatement system in the case of a risk of explosion;
- store liquid wastes in tanks under appropriate controlled pressure and duct the tank vents to the combustion air feed or to another suitable abatement system;
- control the risk of odour during complete shutdown periods when no incineration capacity is available, e.g. by:
 - sending the vented or extracted air to an alternative abatement system, e.g. a wet scrubber, a fixed adsorption bed;
 - minimising the amount of waste in storage, e.g. by interrupting, reducing or transferring waste deliveries, as a part of waste stream management (see BAT 9);
 - storing waste in properly sealed bales.

BAT 22. In order to prevent diffuse emissions of volatile compounds from the handling of gaseous and liquid wastes that are odorous and/or prone to releasing volatile substances at incineration plants, BAT is to feed them to the furnace by direct feeding.

Description

For gaseous and liquid wastes delivered in bulk waste containers (e.g. tankers), direct feeding is carried out by connecting the waste container to the furnace feeding line. The container is then emptied by pressurising it with nitrogen or, if the viscosity is low enough, by pumping the liquid.

For gaseous and liquid wastes delivered in waste containers suitable for incineration (e.g. drums), direct feeding is carried out by introducing the containers directly in the furnace.

Applicability

May not be applicable to the incineration of sewage sludge depending, for example, on the water content and on the need for pre-drying or mixing with other wastes.

BAT 23. In order to prevent or reduce diffuse dust emissions to air from the treatment of slags and bottom ashes, BAT is to include in the environmental management system (see BAT 1) the following diffuse dust emissions management features:

- identification of the most relevant diffuse dust emission sources (e.g. using EN 15445);
- definition and implementation of appropriate actions and techniques to prevent or reduce diffuse emissions over a given time frame.

BAT 24. In order to prevent or reduce diffuse dust emissions to air from the treatment of slags and bottom ashes, BAT is to use an appropriate combination of the techniques given below.

	Technique	Description	Applicability
a.	Enclose and cover equipment	Enclose/encapsulate potentially dusty operations (such as grinding, screening) and/or cover conveyors and elevators. Enclosure can also be accomplished by installing all of the equipment in a closed building.	Installing the equipment in a closed building may not be applicable to mobile treatment devices.
b.	Limit height of discharge	Match the discharge height to the varying height of the heap, automatically if possible (e.g. conveyor belts with adjustable heights).	Generally applicable.
c.	Protect stockpiles against prevailing winds	Protect bulk storage areas or stockpiles with covers or wind barriers such as screening, walling or vertical greenery, as well as correctly orienting the stockpiles in relation to the prevailing wind.	Generally applicable.
d.	Use water sprays	Install water spray systems at the main sources of diffuse dust emissions. The humidification of dust particles aids dust agglomeration and settling. Diffuse dust emissions at stockpiles are reduced by ensuring appropriate humidification of the charging and discharging points, or of the stockpiles themselves.	Generally applicable.
e.	Optimise moisture content	Optimise the moisture content of the slags/bottom ashes to the level required for efficient recovery of metals and mineral materials while minimising the dust release.	Generally applicable.
f.	Operate under subatmospheric pressure	Carry out the treatment of slags and bottom ashes in enclosed equipment or buildings (see technique a) under subatmospheric pressure to enable treatment of the extracted air with an abatement technique (see BAT 26) as channelled emissions.	Only applicable to dry-discharged and other low-moisture bottom ashes.

5.1.5.2 Channelled emissions

5.1.5.2.1 Emissions of dust, metals and metalloids

BAT 25. In order to reduce channelled emissions to air of dust, metals and metalloids from the incineration of waste, BAT is to use one or a combination of the techniques given below.

	Technique	Description	Applicability
a.	Bag filter	See Section 5.2.2	Generally applicable to new plants. Applicable to existing plants within the constraints associated with the operating temperature profile of the FGC system.
b.	Electrostatic precipitator	See Section 5.2.2	Generally applicable.
c.	Dry sorbent injection	See Section 5.2.2. Not relevant for the reduction of dust emissions. Adsorption of metals by injection of activated carbon or other reagents in combination with a dry sorbent injection system or a semi-wet absorber that is used to reduce acid gas emissions.	Generally applicable.
d.	Wet scrubber	See Section 5.2.2. Wet scrubbing systems are not used to remove the main dust load but, installed after other abatement techniques, to further reduce the concentrations of dust, metals and metalloids in the flue-gas.	There may be applicability restrictions due to low water availability, e.g. in arid areas
e.	Fixed- or moving-bed adsorption	See Section 5.2.2. The system is used mainly to adsorb mercury and other metals and metalloids as well as organic compounds including PCDD/F, but also acts as an effective polishing filter for dust.	The applicability may be limited by the overall pressure drop associated with the FGC system configuration. In the case of existing plants, the applicability may be limited by a lack of space.

Table 5.3: BAT-associated emission levels (BAT-AELs) for channelled emissions to air of dust, metals and metalloids from the incineration of waste

Parameter	BAT-AEL (mg/Nm ³)	Averaging period
Dust	< 2–5 ⁽¹⁾	Daily average
Cd+Tl	0.005–0.02	Average over the sampling period
Sb+As+Pb+Cr+Co+Cu+Mn+Ni+V	0.01–0.3	Average over the sampling period

⁽¹⁾ For existing plants dedicated to the incineration of hazardous waste and for which a bag filter is not applicable, the higher end of the BAT-AEL range is 7 mg/Nm³.

The associated monitoring is in BAT 4.

BAT 26. In order to reduce channelled dust emissions to air from the enclosed treatment of slags and bottom ashes with extraction of air (see BAT 24 f), BAT is to treat the extracted air with a bag filter (see Section 5.2.2).

Table 5.4: BAT-associated emission levels (BAT-AELs) for channelled dust emissions to air from the enclosed treatment of slags and bottom ashes with extraction of air

Parameter	BAT-AEL (mg/Nm ³)	Averaging period
Dust	2–5	Average over the sampling period

The associated monitoring is in BAT 4.

5.1.5.2.2 Emissions of HCl, HF and SO₂

BAT 27. In order to reduce channelled emissions of HCl, HF and SO₂ to air from the incineration of waste, BAT is to use one or a combination of the techniques given below.

	Technique	Description	Applicability
a.	Wet scrubber	See Section 5.2.2	There may be applicability restrictions due to low water availability, e.g. in arid areas.
b.	Semi-wet absorber	See Section 5.2.2	Generally applicable.
c.	Dry sorbent injection	See Section 5.2.2	Generally applicable.
d.	Direct desulphurisation	See Section 5.2.2. Used for partial abatement of acid gas emissions upstream of other techniques.	Only applicable to fluidised bed furnaces.
e.	Boiler sorbent injection	See Section 5.2.2. Used for partial abatement of acid gas emissions upstream of other techniques.	Generally applicable.

BAT 28. In order to reduce channelled peak emissions of HCl, HF and SO₂ to air from the incineration of waste while limiting the consumption of reagents and the amount of residues generated from dry sorbent injection and semi-wet absorbers, BAT is to use technique (a) or both of the techniques given below.

	Technique	Description	Applicability
a.	Optimised and automated reagent dosage	The use of continuous HCl and/or SO ₂ measurements (and/or of other parameters that may prove useful for this purpose) upstream and/or downstream of the FGC system for the optimisation of the automated reagent dosage.	Generally applicable
b.	Recirculation of reagents	The recirculation of a proportion of the collected FGC solids to reduce the amount of unreacted reagent(s) in the residues. The technique is particularly relevant in the case of FGC techniques operating with a high stoichiometric excess.	Generally applicable to new plants. Applicable to existing plants within the constraints of the size of the bag filter.

Table 5.5: BAT-associated emission levels (BAT-AELs) for channelled emissions to air of HCl, HF and SO₂ from the incineration of waste

Parameter	BAT-AEL (mg/Nm ³)		Averaging period
	New plant	Existing plant	
HCl	< 2–6 ⁽¹⁾	< 2–8 ⁽¹⁾	Daily average
HF	< 1	< 1	Daily average or average over the sampling period
SO ₂	5–30	5–40	Daily average

⁽¹⁾ The lower end of the BAT-AEL range can be achieved when using a wet scrubber; the higher end of the range may be associated with the use of dry sorbent injection.

The associated monitoring is in BAT 4.

5.1.5.2.3 Emissions of NO_x, N₂O, CO and NH₃

BAT 29. In order to reduce channelled NO_x emissions to air while limiting the emissions of CO and N₂O from the incineration of waste and the emissions of NH₃ from the use of SNCR and/or SCR, BAT is to use an appropriate combination of the techniques given below.

	Technique	Description	Applicability
a.	Optimisation of the incineration process	See Section 5.2.1	Generally applicable.
b.	Flue-gas recirculation	See Section 5.2.2	For existing plants, the applicability may be limited due to technical constraints (e.g. pollutant load in the flue-gas, incineration conditions).
c.	Selective non-catalytic reduction (SNCR)	See Section 5.2.2	Generally applicable.
d.	Selective catalytic reduction (SCR)	See Section 5.2.2	In the case of existing plants, the applicability may be limited by a lack of space.
e.	Catalytic filter bags	See Section 5.2.2	Only applicable to plants fitted with a bag filter.
f.	Optimisation of the SNCR/SCR design and operation	Optimisation of the reagent to NO _x ratio over the cross-section of the furnace or duct, of the size of the reagent drops and of the temperature window in which the reagent is injected.	Only applicable where SNCR and/or SCR is used for the reduction of NO _x emissions.
g.	Wet scrubber	See Section 5.2.2. Where a wet scrubber is used for acid gas abatement, and in particular with SNCR, unreacted ammonia is absorbed by the scrubbing liquor and, once stripped, can be recycled as SNCR or SCR reagent.	There may be applicability restrictions due to low water availability, e.g. in arid areas.

Table 5.6: BAT-associated emission levels (BAT-AELs) for channelled NO_x and CO emissions to air from the incineration of waste and for channelled NH₃ emissions to air from the use of SNCR and/or SCR

Parameter	BAT-AEL (mg/Nm ³)		Averaging period
	New plant	Existing plant	
NO _x	50–120 ⁽¹⁾	50–150 ⁽¹⁾ ⁽²⁾	Daily average
CO	10–50	10–50	
NH ₃	2–10 ⁽¹⁾	2–10 ⁽¹⁾ ⁽³⁾	

⁽¹⁾ The lower end of the BAT-AEL range can be achieved when using SCR. The lower end of the BAT-AEL range may not be achievable when incinerating waste with a high nitrogen content (e.g. residues from the production of organic nitrogen compounds).

⁽²⁾ The higher end of the BAT-AEL range is 180 mg/Nm³ where SCR is not applicable.

⁽³⁾ For existing plants fitted with SNCR without wet abatement techniques, the higher end of the BAT-AEL range is 15 mg/Nm³.

The associated monitoring is in BAT 4.

5.1.5.2.4 Emissions of organic compounds

BAT 30. In order to reduce channelled emissions to air of organic compounds including PCDD/F and PCBs from the incineration of waste, BAT is to use techniques (a), (b), (c), (d), and one or a combination of techniques (e) to (i) given below.

	Technique	Description	Applicability
a.	Optimisation of the incineration process	See Section 5.2.1. Optimisation of incineration parameters to promote the oxidation of organic compounds including PCDD/F and PCBs present in the waste, and to prevent their and their precursors' (re)formation.	Generally applicable.
b.	Control of the waste feed	Knowledge and control of the combustion characteristics of the waste being fed into the furnace, to ensure optimal and, as far as possible, homogeneous and stable incineration conditions.	Not applicable to clinical waste or to municipal solid waste.
c.	On-line and off-line boiler cleaning	Efficient cleaning of the boiler bundles to reduce the dust residence time and accumulation in the boiler, thus reducing PCDD/F formation in the boiler. A combination of on-line and off-line boiler cleaning techniques is used.	Generally applicable.
d.	Rapid flue-gas cooling	Rapid cooling of the flue-gas from temperatures above 400 °C to below 250 °C before dust abatement to prevent the <i>de novo</i> synthesis of PCDD/F. This is achieved by appropriate design of the boiler and/or with the use of a quench system. The latter option limits the amount of energy that can be recovered from the flue-gas and is used in particular in the case of incinerating hazardous wastes with a high halogen content.	Generally applicable
e.	Dry sorbent injection	See Section 5.2.2. Adsorption by injection of activated carbon or other reagents, generally combined with a bag filter where a reaction layer is created in the filter cake and the solids generated are removed.	Generally applicable.

f.	Fixed- or moving-bed adsorption	See Section 5.2.2.	The applicability may be limited by the overall pressure drop associated with the FGC system. In the case of existing plants, the applicability may be limited by a lack of space.
g.	SCR	See Section 5.2.2. Where SCR is used for NO _x abatement, the adequate catalyst surface of the SCR system also provides for the partial reduction of the emissions of PCDD/F and PCBs. The technique is generally used in combination with technique (e), (f) or (i).	In the case of existing plants, the applicability may be limited by a lack of space.
h.	Catalytic filter bags	See Section 5.2.2	Only applicable to plants fitted with a bag filter.
i.	Carbon sorbent in a wet scrubber	PCDD/F and PCBs are adsorbed by carbon sorbent added to the wet scrubber, either in the scrubbing liquor or in the form of impregnated packing elements. The technique is used for the removal of PCDD/F in general, and also to prevent and/or reduce the re-emission of PCDD/F accumulated in the scrubber (the so-called memory effect) occurring especially during shutdown and start-up periods	Only applicable to plants fitted with a wet scrubber.

Table 5.7: BAT-associated emission levels (BAT-AELs) for channelled emissions to air of TVOC, PCDD/F and dioxin-like PCBs from the incineration of waste

Parameter	Unit	BAT-AEL		Averaging period
		New plant	Existing plant	
TVOC	mg/Nm ³	< 3–10	< 3–10	Daily average
PCDD/F ⁽¹⁾	ng I-TEQ/Nm ³	< 0.01–0.04	< 0.01–0.06	Average over the sampling period
		< 0.01–0.06	< 0.01–0.08	Long-term sampling period ⁽²⁾
PCDD/F + dioxin-like PCBs ⁽¹⁾	ng WHO-TEQ/Nm ³	< 0.01–0.06	< 0.01–0.08	Average over the sampling period
		< 0.01–0.08	< 0.01–0.1	Long-term sampling period ⁽²⁾

⁽¹⁾ Either the BAT-AEL for PCDD/F or the BAT-AEL for PCDD/F + dioxin-like PCBs applies.
⁽²⁾ The BAT-AEL does not apply if the emission levels are proven to be sufficiently stable.

The associated monitoring is in BAT 4.

5.1.5.2.5 Emissions of mercury

BAT 31. In order to reduce channelled mercury emissions to air (including mercury emission peaks) from the incineration of waste, BAT is to use one or a combination of the techniques given below.

	Technique	Description	Applicability
a.	Wet scrubber (low pH)	<p>See Section 5.2.2.</p> <p>A wet scrubber operated at a pH value around 1.</p> <p>The mercury removal rate of the technique can be enhanced by adding reagents and/or adsorbents to the scrubbing liquor, e.g.:</p> <ul style="list-style-type: none"> oxidants such as hydrogen peroxide to transform elemental mercury to a water-soluble oxidised form; sulphur compounds to form stable complexes or salts with mercury; carbon sorbent to adsorb mercury, including elemental mercury. <p>When designed for a sufficiently high buffer capacity for mercury capture, the technique effectively prevents the occurrence of mercury emission peaks.</p>	There may be applicability restrictions due to low water availability, e.g. in arid areas.
b.	Dry sorbent injection	<p>See Section 5.2.2.</p> <p>Adsorption by injection of activated carbon or other reagents, generally combined with a bag filter where a reaction layer is created in the filter cake and the solids generated are removed.</p>	Generally applicable.
c.	Injection of special, highly reactive activated carbon	<p>Injection of highly reactive activated carbon doped with sulphur or other reagents to enhance the reactivity with mercury.</p> <p>Usually, the injection of this special activated carbon is not continuous but only takes place when a mercury peak is detected. For this purpose, the technique can be used in combination with the continuous monitoring of mercury in the raw flue-gas.</p>	May not be applicable to plants dedicated to the incineration of sewage sludge.
d.	Boiler bromine addition	<p>Bromide added to the waste or injected into the furnace is converted at high temperatures to elemental bromine, which oxidises elemental mercury to the water-soluble and highly adsorbable HgBr_2.</p> <p>The technique is used in combination with a downstream abatement technique such as a wet scrubber or an activated carbon injection system.</p> <p>Usually, the injection of bromide is not continuous but only takes place when a mercury peak is detected. For this purpose, the technique can be used in combination with the continuous monitoring of mercury in the raw flue-gas.</p>	Generally applicable.
e.	Fixed- or moving-bed adsorption	<p>See Section 5.2.2.</p> <p>When designed for a sufficiently high adsorption capacity, the technique effectively prevents the occurrence of mercury emission peaks.</p>	The applicability may be limited by the overall pressure drop associated with the FGC system. In the case of existing plants, the applicability may be limited by a lack of space.

Table 5.8: BAT-associated emission levels (BAT-AELs) for channelled mercury emissions to air from the incineration of waste

Parameter	BAT-AEL ($\mu\text{g}/\text{Nm}^3$) ⁽¹⁾		Averaging period
	New plant	Existing plant	
Hg	< 5–20 ⁽²⁾	< 5–20 ⁽²⁾	Daily average or average over the sampling period
	1–10	1–10	Long-term sampling period

⁽¹⁾ Either the BAT-AEL for daily average or average over the sampling period or the BAT-AEL for long-term sampling period applies. The BAT-AEL for long-term sampling may apply in the case of plants incinerating waste with a proven low and stable mercury content (e.g. mono-streams of waste of a controlled composition).

⁽²⁾ The lower end of the BAT-AEL ranges may be achieved when:

- incinerating wastes with a proven low and stable mercury content (e.g. mono-streams of waste of a controlled composition), or
- using specific techniques to prevent or reduce the occurrence of mercury peak emissions while incinerating non-hazardous waste.

The higher end of the BAT-AEL ranges may be associated with the use of dry sorbent injection.

As an indication, the half-hourly average mercury emission levels will generally be:

- < 15–40 $\mu\text{g}/\text{Nm}^3$ for existing plants;
- < 15–35 $\mu\text{g}/\text{Nm}^3$ for new plants.

The associated monitoring is in BAT 4.

5.1.6 Emissions to water

BAT 32. In order to prevent the contamination of uncontaminated water, to reduce emissions to water, and to increase resource efficiency, BAT is to segregate waste water streams and to treat them separately, depending on their characteristics.

Description

Waste water streams (e.g. surface run-off water, cooling water, waste water from flue-gas treatment and from bottom ash treatment, drainage water collected from the waste reception, handling and storage areas (see BAT 12 (a)) are segregated to be treated separately based on their characteristics and on the combination of treatment techniques required. Uncontaminated water streams are segregated from waste water streams that require treatment.

When recovering hydrochloric acid and/or gypsum from the scrubber's effluent, the waste waters arising from the different stages (acidic and alkaline) of the wet scrubbing system are treated separately.

Applicability

Generally applicable to new plants.

Applicable to existing plants within the constraints associated with the configuration of the water collection system.

BAT 33. In order to reduce water usage and to prevent or reduce the generation of waste water from the incineration plant, BAT is to use one or a combination of the techniques given below.

	Technique	Description	Applicability
a.	Waste-water-free FGC techniques	Use of FGC techniques that do not generate waste water (e.g. dry sorbent injection or semi-wet absorber, see Section 5.2.2).	May not be applicable to the incineration of hazardous waste with a high halogen content.
b.	Injection of waste water from FGC	Waste water from FGC is injected into the hotter parts of the FGC system.	Only applicable to the incineration of municipal solid waste.
c.	Water reuse/recycling	Residual aqueous streams are reused or recycled. The degree of reuse/recycling is limited by the quality requirements of the process to which the water is directed.	Generally applicable.
d.	Dry bottom ash handling	Dry, hot bottom ash falls from the grate onto a transport system and is cooled down by ambient air. No water is used in the process.	Only applicable to grate furnaces. There may be technical restrictions that prevent retrofitting to existing incineration plants.

BAT 34. In order to reduce emissions to water from FGC and/or from the storage and treatment of slags and bottom ashes, BAT is to use an appropriate combination of the techniques given below, and to use secondary techniques as close as possible to the source in order to avoid dilution.

	Technique	Typical pollutants targeted
Primary techniques		
a.	Optimisation of the incineration process (see BAT 14) and/or of the FGC system (e.g. SNCR/SCR, see BAT 29 (f))	Organic compounds including PCDD/F, ammonia/ammonium
Secondary techniques ⁽¹⁾		
Preliminary and primary treatment		
b.	Equalisation	All pollutants
c.	Neutralisation	Acids, alkalis
d.	Physical separation, e.g. screens, sieves, grit separators, primary settlement tanks	Gross solids, suspended solids
Physico-chemical treatment		
e.	Adsorption on activated carbon	Organic compounds including PCDD/F, mercury
f.	Precipitation	Dissolved metals/metalloids, sulphate
g.	Oxidation	Sulphide, sulphite, organic compounds
h.	Ion exchange	Dissolved metals/metalloids
i.	Stripping	Purgeable pollutants (e.g. ammonia/ammonium)
j.	Reverse osmosis	Ammonia/ammonium, metals/metalloids, sulphate, chloride, organic compounds
Final solids removal		
k.	Coagulation and flocculation	Suspended solids, particulate-bound metals/metalloids
l.	Sedimentation	
m.	Filtration	
n.	Flotation	
⁽¹⁾ The descriptions of the techniques are given in Section 5.2.3.		

Table 5.9: BAT-AELs for direct emissions to a receiving water body

Parameter		Process	Unit	BAT-AEL ⁽¹⁾
Total suspended solids (TSS)		FGC Bottom ash treatment	mg/l	10–30
Total organic carbon (TOC)		FGC Bottom ash treatment		15–40
Metals and metalloids	As	FGC		0.01–0.05
	Cd	FGC		0.005–0.03
	Cr	FGC		0.01–0.1
	Cu	FGC		0.03–0.15
	Hg	FGC		0.001–0.01
	Ni	FGC		0.03–0.15
	Pb	FGC Bottom ash treatment		0.02–0.06
	Sb	FGC		0.02–0.9
	Tl	FGC		0.005–0.03
Zn	FGC	0.01–0.5		
Ammonium-nitrogen (NH ₄ -N)		Bottom ash treatment		10–30
Sulphate (SO ₄ ²⁻)		Bottom ash treatment		400–1 000
PCDD/F		FGC	ng I-TEQ/l	0.01–0.05

⁽¹⁾ The averaging periods are defined in the General considerations.

The associated monitoring is in BAT 6.

Table 5.10: BAT-AELs for indirect emissions to a receiving water body

Parameter		Process	Unit	BAT-AEL ⁽¹⁾ ⁽²⁾
Metals and metalloids	As	FGC	mg/l	0.01–0.05
	Cd	FGC		0.005–0.03
	Cr	FGC		0.01–0.1
	Cu	FGC		0.03–0.15
	Hg	FGC		0.001–0.01
	Ni	FGC		0.03–0.15
	Pb	FGC Bottom ash treatment		0.02–0.06
	Sb	FGC		0.02–0.9
	Tl	FGC		0.005–0.03
Zn	FGC	0.01–0.5		
PCDD/F		FGC	ng I-TEQ/l	0.01–0.05

⁽¹⁾ The averaging periods are defined in the General considerations.
⁽²⁾ The BAT-AELs may not apply if the downstream waste water treatment plant is designed and equipped appropriately to abate the pollutants concerned, provided this does not lead to a higher level of pollution in the environment.

The associated monitoring is in BAT 6.

5.1.7 Material efficiency

BAT 35. In order to increase resource efficiency, BAT is to handle and treat bottom ashes separately from FGC residues.

BAT 36. In order to increase resource efficiency for the treatment of slags and bottom ashes, BAT is to use an appropriate combination of the techniques given below based on a risk assessment depending on the hazardous properties of the slags and bottom ashes.

	Technique	Description	Applicability
a.	Screening and sieving	Oscillating screens, vibrating screens and rotary screens are used for an initial classification of the bottom ashes by size before further treatment.	Generally applicable.
b.	Crushing	Mechanical treatment operations intended to prepare materials for the recovery of metals or for the subsequent use of those materials, e.g. in road and earthworks construction	Generally applicable.
c.	Aeraulic separation	Aeraulic separation is used to sort the light, unburnt fractions commingled in the bottom ashes by blowing off light fragments. A vibrating table is used to transport the bottom ashes to a chute, where the material falls through an air stream that blows uncombusted light materials, such as wood, paper or plastic, onto a removal belt or into a container, so that they can be returned to incineration.	Generally applicable.
d.	Recovery of ferrous and non-ferrous metals	Different techniques are used, including: <ul style="list-style-type: none"> • magnetic separation for ferrous metals; • eddy current separation for non-ferrous metals; • induction all-metal separation. 	Generally applicable.
e.	Ageing	The ageing process stabilises the mineral fraction of the bottom ashes by uptake of atmospheric CO ₂ (carbonation), draining of excess water and oxidation. Bottom ashes, after the recovery of metals, are stored in the open air or in covered buildings for several weeks, generally on an impermeable floor allowing for drainage and run-off water to be collected for treatment. The stockpiles may be wetted to optimise the moisture content to favour the leaching of salts and the carbonation process. The wetting of bottom ashes also helps prevent dust emissions.	Generally applicable.
f.	Washing	The washing of bottom ashes enables the production of a material for recycling with minimal leachability of soluble substances (e.g. salts).	Generally applicable.

5.1.8 Noise

BAT 37. In order to prevent or, where that is not practicable, to reduce noise emissions, BAT is to use one or a combination of the techniques given below.

Technique		Description	Applicability
a.	Appropriate location of equipment and buildings	Noise levels can be reduced by increasing the distance between the emitter and the receiver and by using buildings as noise screens.	In the case of existing plants, the relocation of equipment may be restricted by a lack of space or by excessive costs.
b.	Operational measures	These include: <ul style="list-style-type: none"> • improved inspection and maintenance of equipment; • closing of doors and windows of enclosed areas, if possible; • operation of equipment by experienced staff; • avoidance of noisy activities at night, if possible; • provisions for noise control during maintenance activities. 	Generally applicable.
c.	Low-noise equipment	This includes low-noise compressors, pumps and fans.	Generally applicable when existing equipment is replaced or new equipment is installed.
d.	Noise attenuation	Noise propagation can be reduced by inserting obstacles between the emitter and the receiver. Appropriate obstacles include protection walls, embankments and buildings.	In the case of existing plants, the insertion of obstacles may be restricted by a lack of space.
e.	Noise-control equipment/ infrastructure	This includes: <ul style="list-style-type: none"> • noise-reducers; • equipment insulation; • enclosure of noisy equipment; • soundproofing of buildings. 	In the case of existing plants, the applicability may be limited by a lack of space.

5.2 Descriptions of techniques

5.2.1 General techniques

Technique	Description
Advanced control system	The use of a computer-based automatic system to control the combustion efficiency and support the prevention and/or reduction of emissions. This also includes the use of high-performance monitoring of operating parameters and of emissions.
Optimisation of the incineration process	Optimisation of the waste feed rate and composition, of the temperature, and of the flow rates and points of injection of the primary and secondary combustion air to effectively oxidise the organic compounds while reducing the generation of NO _x . Optimisation of the design and operation of the furnace (e.g. flue-gas temperature and turbulence, flue-gas and waste residence time, oxygen level, waste agitation).

5.2.2 Techniques to reduce emissions to air

Technique	Description
Bag filter	Bag or fabric filters are constructed from porous woven or felted fabric through which gases are passed to remove particles. The use of a bag filter requires the selection of a fabric suitable for the characteristics of the flue-gas and the maximum operating temperature.
Boiler sorbent injection	The injection of magnesium- or calcium-based absorbents at a high temperature in the boiler post-combustion area, to achieve partial abatement of acid gases. The technique is highly effective for the removal of SO _x and HF, and provides additional benefits in terms of flattening emission peaks.
Catalytic filter bags	Filter bags are either impregnated with a catalyst or the catalyst is directly mixed with organic material in the production of the fibres used for the filter medium. Such filters can be used to reduce PCDD/F emissions as well as, in combination with a source of NH ₃ , to reduce NO _x emissions.
Direct desulphurisation	The addition of magnesium- or calcium-based absorbents to the bed of a fluidised bed furnace.
Dry sorbent injection	The injection and dispersion of sorbent in the form of a dry powder in the flue-gas stream. Alkaline sorbents (e.g. sodium bicarbonate, hydrated lime) are injected to react with acid gases (HCl, HF and SO _x). Activated carbon is injected or co-injected to adsorb in particular PCDD/F and mercury. The resulting solids are removed, most often with a bag filter. The excess reactive agents may be recirculated to decrease their consumption, possibly after reactivation by maturation or steam injection (see BAT 28 b).
Electrostatic precipitator	Electrostatic precipitators (ESPs) operate such that particles are charged and separated under the influence of an electrical field. Electrostatic precipitators are capable of operating under a wide range of conditions. The abatement efficiency may depend on the number of fields, residence time (size), and upstream particle removal devices. They generally include between two and five fields. Electrostatic precipitators can be of the dry or of the wet type depending on the technique used to collect the dust from the electrodes. Wet ESPs are typically used at the polishing stage to remove residual dust and droplets after wet scrubbing.
Fixed- or moving-bed adsorption	The flue-gas is passed through a fixed- or a moving-bed filter where an adsorbent (e.g. activated coke, activated lignite or a carbon-impregnated polymer) is used to adsorb pollutants.
Flue-gas recirculation	Recirculation of a part of the flue-gas to the furnace to replace a part of the fresh combustion air, with the dual effect of cooling the temperature and limiting the O ₂ content for nitrogen oxidation, thus limiting the NO _x generation. It implies the supply of flue-gas from the furnace into the flame to reduce the oxygen content and therefore the temperature of the flame.

Technique	Description
	This technique also reduces the flue-gas energy losses. Energy savings are also achieved when the recirculated flue-gas is extracted before FGC, by reducing the gas flow through the FGC system and the size of the required FGC system.
Selective catalytic reduction (SCR)	Selective reduction of nitrogen oxides with ammonia or urea in the presence of a catalyst. The technique is based on the reduction of NO _x to nitrogen in a catalytic bed by reaction with ammonia at an optimum operating temperature that is typically around 200–450 °C for the high-dust type and 170–250 °C for the tail-end type. In general, ammonia is injected as an aqueous solution; the ammonia source can also be anhydrous ammonia or a urea solution. Several layers of catalyst may be applied. A higher NO _x reduction is achieved with the use of a larger catalyst surface, installed as one or more layers. 'In-duct' or 'slip' SCR combines SNCR with downstream SCR which reduces the ammonia slip from SNCR.
Selective non-catalytic reduction (SNCR)	Selective reduction of nitrogen oxides to nitrogen with ammonia or urea at high temperatures and without catalyst. The operating temperature window is maintained between 800 °C and 1 000 °C for optimal reaction. The performance of the SNCR system can be increased by controlling the injection of the reagent from multiple lances with the support of a (fast-reacting) acoustic or infrared temperature measurement system so as to ensure that the reagent is injected in the optimum temperature zone at all times.
Semi-wet absorber	Also called semi-dry absorber. An alkaline aqueous solution or suspension (e.g. milk of lime) is added to the flue-gas stream to capture the acid gases. The water evaporates and the reaction products are dry. The resulting solids may be recirculated to reduce reagent consumption (see BAT 28 b). This technique includes a range of different designs, including <i>flash-dry</i> processes which consist of injecting water (providing for fast gas cooling) and reagent at the filter inlet.
Wet scrubber	Use of a liquid, typically water or an aqueous solution/suspension, to capture pollutants from the flue-gas by absorption, in particular acid gases, as well as other soluble compounds and solids. To adsorb mercury and/or PCDD/F, carbon sorbent (as a slurry or as carbon-impregnated plastic packing) can be added to the wet scrubber. Different types of scrubber designs are used, e.g. jet scrubbers, rotation scrubbers, Venturi scrubbers, spray scrubbers and packed tower scrubbers.

5.2.3 Techniques to reduce emissions to water

Technique	Description
Adsorption on activated carbon	The removal of soluble substances (solutes) from the waste water by transferring them to the surface of solid, highly porous particles (the adsorbent). Activated carbon is typically used for the adsorption of organic compounds and mercury.
Precipitation	The conversion of dissolved pollutants into insoluble compounds by adding precipitants. The solid precipitates formed are subsequently separated by sedimentation, flotation or filtration. Typical chemicals used for metal precipitation are lime, dolomite, sodium hydroxide, sodium carbonate, sodium sulphide and organosulphides. Calcium salts (other than lime) are used to precipitate sulphate or fluoride.
Coagulation and flocculation	Coagulation and flocculation are used to separate suspended solids from waste water and are often carried out in successive steps. Coagulation is carried out by adding coagulants (e.g. ferric chloride) with charges opposite to those of the suspended solids. Flocculation is carried out by adding polymers, so that collisions of microfloc particles cause them to bond thereby producing larger flocs. The flocs formed are subsequently separated by sedimentation, air flotation or filtration.
Equalisation	Balancing of flows and pollutant loads by using tanks or other management techniques.
Filtration	The separation of solids from waste water by passing it through a porous medium. It includes different types of techniques, e.g. sand filtration, microfiltration and ultrafiltration.
Flotation	The separation of solid or liquid particles from waste water by attaching them to fine gas bubbles, usually air. The buoyant particles accumulate at the water surface and are collected with skimmers.
Ion exchange	The retention of ionic pollutants from waste water and their replacement by more acceptable ions using an ion exchange resin. The pollutants are temporarily retained and afterwards released into a regeneration or backwashing liquid.
Neutralisation	The adjustment of the pH of the waste water to a neutral value (approximately 7) by the addition of chemicals. Sodium hydroxide (NaOH) or calcium hydroxide (Ca(OH) ₂) is generally used to increase the pH whereas sulphuric acid (H ₂ SO ₄), hydrochloric acid (HCl) or carbon dioxide (CO ₂) is used to decrease the pH. The precipitation of some substances may occur during neutralisation.
Oxidation	The conversion of pollutants by chemical oxidising agents to similar compounds that are less hazardous and/or easier to abate. In the case of waste water from the use of wet scrubbers, air may be used to oxidise sulphite (SO ₃ ²⁻) to sulphate (SO ₄ ²⁻).
Reverse osmosis	A membrane process in which a pressure difference applied between the compartments separated by the membrane causes water to flow from the more concentrated solution to the less concentrated one.
Sedimentation	The separation of suspended solids by gravitational settling.
Stripping	The removal of purgeable pollutants (e.g. ammonia) from waste water by contact with a high flow of a gas current in order to transfer them to the gas phase. The pollutants are subsequently recovered (e.g. by condensation) for further use or disposal. The removal efficiency may be enhanced by increasing the temperature or reducing the pressure.

5.2.4 Management techniques

Technique	Description
Odour management plan	<p>The odour management plan is part of the EMS (see BAT 1) and includes:</p> <ol style="list-style-type: none"> a protocol for conducting odour monitoring in accordance with EN standards (e.g. dynamic olfactometry according to EN 13725 to determine the odour concentration); it may be complemented by measurement/estimation of odour exposure (e.g. according to EN 16841-1 or EN 16841-2) or estimation of odour impact; a protocol for response to identified odour incidents, e.g. complaints; an odour prevention and reduction programme designed to identify the source(s), to characterise the contributions of the sources, and to implement prevention and/or reduction measures.
Noise management plan	<p>The noise management plan is part of the EMS (see BAT 1) and includes:</p> <ol style="list-style-type: none"> a protocol for conducting noise monitoring; a protocol for response to identified noise incidents, e.g. complaints; a noise reduction programme designed to identify the source(s), to measure/estimate noise exposure, to characterise the contributions of the source(s) and to implement prevention and/or reduction measures.
Accident management plan	<p>An accident management plan is part of the EMS (see BAT 1) and identifies hazards posed by the installation and the associated risks and defines measures to address these risks. It considers the inventory of pollutants present or likely to be present which could have environmental consequences if they escape. It can be drawn up using for example FMEA (Failure Mode and Effects Analysis) and/or FMECA (Failure Mode, Effects and Criticality Analysis).</p> <p>The accident management plan includes the setting up and implementation of a fire prevention, detection and control plan, which is risk-based and includes the use of automatic fire detection and warning systems, and of manual and/or automatic fire intervention and control systems. The fire prevention, detection and control plan is relevant in particular for:</p> <ul style="list-style-type: none"> waste storage and pre-treatment areas; furnace loading areas; electrical control systems; bag filters; fixed adsorption beds. <p>The accident management plan also includes, in particular in the case of installations where hazardous wastes are received, personnel training programmes regarding:</p> <ul style="list-style-type: none"> explosion and fire prevention; fire extinguishing; knowledge of chemical risks (labelling, carcinogenic substances, toxicity, corrosion, fire).

6 EMERGING TECHNIQUES

Article 3(14) of Directive 2010/75/EU defines an 'emerging technique' as a 'novel technique for an industrial activity that, if commercially developed, could provide either a higher general level of protection of the environment or at least the same level of protection of the environment and higher cost savings than existing best available techniques'. This chapter contains those techniques that may appear in the near future and that may be applicable to the waste incineration sector.

6.1 Reheating of turbine steam

Description

Steam reheating after the first pass through the steam turbine to raise the steam parameters of the live steam in order to increase electricity production.

Technical description

[2, InfoMil 2002]

An option to increase the efficiency of electricity production is the reheating of turbine steam after its first passage through the turbine. For this application, the steam temperature is typically limited to less than 430 °C, but the steam pressure increases. Figure 6.1 provides a simplified process schem for this option.

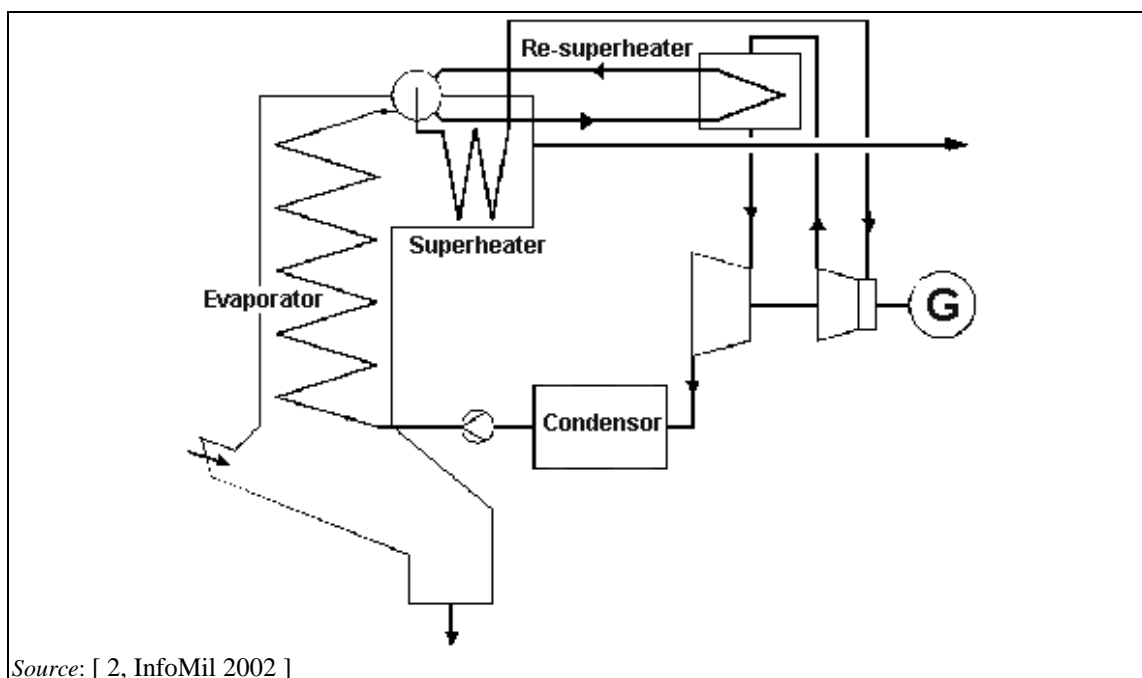

Source: [2, InfoMil 2002]

Figure 6.1: Example of the reheating of steam

After the first passage through the high-pressure section of the turbine, the resulting steam is superheated again and subsequently used in the turbine's mid- and low-pressure sections.

Usually, after expanding in the HP turbine, the steam has a lower pressure (typically 10–20 % of the pressure it had on entering) and is reheated with flue-gas in the boiler to the same temperature. According to the simplified drawing (see Figure 6.1), the steam is heated with either boiler water or saturated steam.

Achieved environmental benefits

Typical electrical efficiency increases are in the range of approximately 2–3 %. Higher efficiency increases, of up to 4.7 % have been however recently reported. [151, AEB Amsterdam 2017]

Environmental performance and operational data

This technique being fully proven in large electricity generation plants, the technological risks are considered to be limited. However, there are only a few examples of applications in the waste incineration sector due to economic factors.

In the Netherlands, one large plant uses this technique and has been in operation since 2007. This plant has two incineration lines with a capacity of 90 MW_{th} and 269 000 t/year each, feeding steam to a single common turbine. The achieved yearly average net electrical efficiency is around 30.7 %. [151, AEB Amsterdam 2017]

Cross-media effects

None reported.

Technical considerations relevant to applicability

No information provided.

Economics

The application of this technique may be influenced by economic feasibility, which is mainly determined by the additional investment costs and by electricity prices.

The additional investment costs for realising the reheating concept at the existing Dutch plant were reported to be very high, with the availability of subsidies being critical for the investment decision.

Driving force for implementation

Increased electrical energy efficiency.

Example plants

One 538 000 t/year WI plant in the Netherlands. [151, AEB Amsterdam 2017]

Reference literature

[2, InfoMil 2002], [151, AEB Amsterdam 2017], [152, AEB Amsterdam 2007]

6.2 Oil scrubber for the reduction of polyhalogenated aromatics and polyaromatic hydrocarbons (PAHs) in the flue-gases from incineration plants

Description

Oil is used as scrubbing liquor in a wet scrubber to absorb organic compounds.

Technical description

Dioxins and furans have very low solubility in water and therefore they are not removed in wet scrubbers to a significant and reliable extent. Any removal which does take place is generally due to the removal of PCDD/F that are adsorbed onto dust removed in the wet scrubber. At best, there is some depletion by condensation of, predominantly, the higher molecular weight hexa- to octa- species from the gas phase into the relatively cold wash liquor. However, dioxins and furans (and many other organic species) are more lipophilic. A high-boiling partly unsaturated oil or an oil-water emulsion of such oil therefore provides suitable scrubbing media.

Achieved environmental benefits

Reduction of emissions to air of organic compounds.

Environmental performance and operational data

The oil/emulsion and absorbed dioxins and furans are exchanged and disposed of as soon as they reach a limit value of 0.1 mg/kg. The supply quantity is determined so that there is an exchange three to four times a year. This helps prevent excessive ageing of the oil. The contaminated liquor is incinerated in the furnace. To do this, the oil is pumped into a slop wagon (a mobile tank with safety installations) and from there fed directly into a burner in the incineration plant.

This process includes a countercurrent scrubber column as its tertiary cleaning stage with a closed oil circuit (see Figure 6.2).

To minimise the number of oil-carrying plant components, a sump is used as a scrubbing media reservoir. The circulation flow rate is determined according to the packing cross-section. The oil/emulsion is heated by a heat exchanger to approximately 15–20 °C above the flue-gas temperature to prevent water from condensing from the vapour-saturated gas.

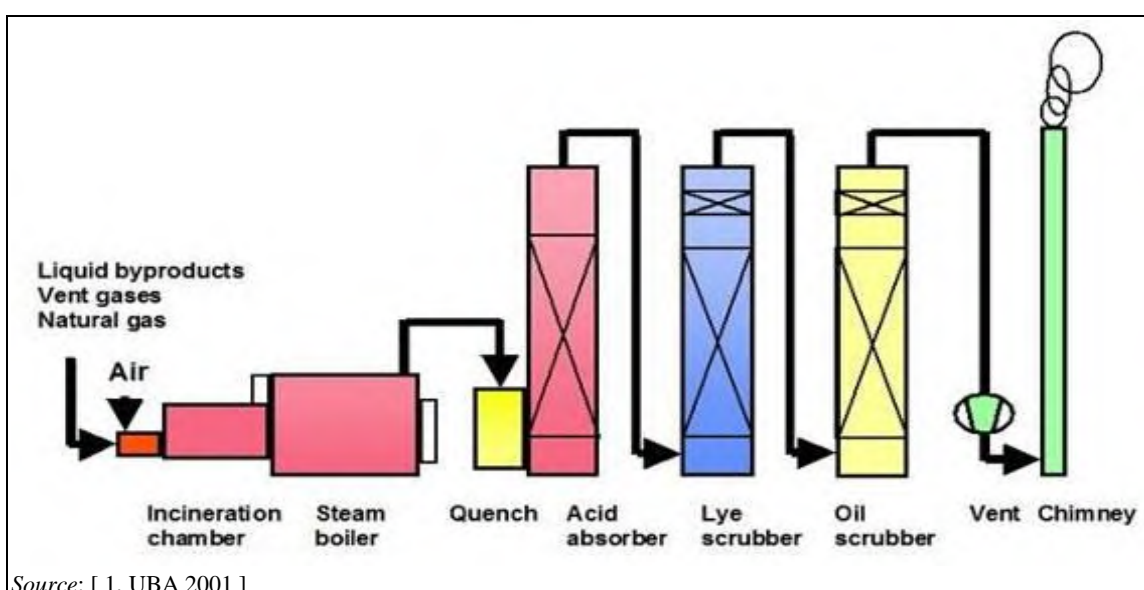

Figure 6.2: Schematic of a waste incineration plant with a downstream oil scrubber for dioxin deposition

Cross-media effects

No information provided.

Technical considerations relevant to applicability

Generally applicable.

Economics

No information provided.

Driving force for implementation

Reduction of emissions of organic compounds.

Example plants

No information provided.

Reference literature

[1, UBA 2001]

6.3 Flameless pressurised oxycombustion

Description

Waste is incinerated by flameless combustion in a pressurised atmosphere of oxygen, carbon dioxide and water vapour, at temperatures of 1 250–1 500 °C.

Technical description

The operating conditions inside the oxidation reactor (residence time: > 2.5 seconds, temperature of 1 250–1 500 °C and pressure of 4–15 absolute bar) enable the complete incineration of the inlet organic compounds (with negligible production of undesirable organic by-products such as PAHs, PCDD/F and PCBs). The high combustion temperature melts the non-combustible materials, forming vitrified slags. This high temperature also represents a condition which thermodynamically and kinetically inhibits sulphur dioxide conversion into sulphur trioxide.

In steady-state conditions, flue-gases leaving the reactor are at a temperature within 1 250–1 500 °C. A fraction of the flue-gas is recycled into the reactor to control the combustion temperature. Another fraction is mixed by the quencher together with the hot flue-gases coming from the reactor in order to have a compatible boiler inlet temperature (600–750 °C).

Slags flow along the bottom of the reactor, leaving through a heated conduit to avoid solidification. In this way, such molten material falls down into a water quencher where it solidifies in vitreous form, shattering into grains of sizes of 0.1–3 mm.

Flue-gases are treated to reduce the amount of dust and acids. The flue-gas flow rate is smaller due to the use of pure oxygen, instead of air.

Liquid and solids with water and sludge wastes can be fed to the reactor.

Heat recovery is performed, producing steam at high pressure and temperature (up to 600 °C and 240 bar) and using the flue-gas water vapour condensation that contributes about 10–15 % to the overall thermal balance. Overall, the thermal efficiency of the plant can be as high as 95–99 % (input waste energy as LHV).

Achieved environmental benefits

Reduction of emissions to air, and production of inert slags.

Environmental performance and operational data

A two-stage wet scrubber is used to clean the flue-gas, followed by a condensation scrubber to recover the flue-gas latent heat. The condensed water is also recovered in the process. Limestone is used in the scrubber's second stage. The emissions to air from the process are reported in Table 6.1 for the treatment of three different examples of waste (wastes from soil and groundwater remediation containing hazardous substances – EWC19.13.01*, municipal wastes – EWC 19.12.12, and organic wastes containing hazardous substances – EWC 16.03.05*).

Table 6.1: Emissions to air of the flameless pressurised oxycombustion process using three different waste types

Parameter	Unit	Emission values		
		19.13.01*	19.12.12	16.03.05*
Dust	mg/Nm ³	0.8	9.6	4.6
Hg	mg/Nm ³	0.001	0.003	
Sb + As + Pb + Cr + Co + Cu + Mn + Ni + V	mg/Nm ³	0.08	0.1	0.07
Cd + Tl	mg/Nm ³	< 0.001	< 0.001	0.00001
PCDD/F	ng I-TEQ/Nm ³	0.001	0.001	< 0.0008
Dioxin-like PCBs	ng WHO-TEQ/Nm ³	0.0001	0.0001	0.00006
PAHs	ng/Nm ³	< 10	< 10	< 25
HCl	mg/Nm ³	0.9	NA	< 0.008
NO _x	mg/Nm ³	141	180	21.5
SO _x	mg/Nm ³	< 7	1.1	< 5
HF	mg/Nm ³	0.2	NA	0.55

Source: [93, Italy 2015]

Table 6.2 reports the results of the leaching test done on the slag produced by the flameless pressurised oxycombustion process for the treatment of same three different examples of waste.

Table 6.2: Leaching test of the slag produced by the flameless pressurised oxycombustion process using three different waste types

Parameter	Unit	Emission values		
		19.13.01*	19.12.12	16.03.05*
pH (final)		NA	3.32	NA
Total dissolved solids	mg/l	25	36	< 100
Dissolved organic carbon (DOC)	mg/l	< 0.125	0.615	< 10
Chlorides	mg/l	< 0.004	0.357	0.003
Fluorides	mg/l	0.001	< 0.0105	0.01
Sulphates	mg/l	0.047	0.283	0.04
Antimony	mg/l	0.000144	0.00123	0.002
Arsenic	mg/l	0.000187	0.000392	< 0.01
Barium	mg/l	< 0.001 2	0.00307	< 0.001
Cadmium	mg/l	0.000087	< 0.000072	< 0.001
Chromium	mg/l	0.00498	0.017	0.02
Mercury	mg/l	< 0.000044	< 0.000054	0.005
Molybdenum	mg/l	0.00187	0.00305	0.04
Nickel	mg/l	0.00181	0.00319	< 0.003
Lead	mg/l	0.000235	0.00604	0.05
Copper	mg/l	0.00306	0.0206	< 0.05
Selenium	mg/l	0.000158	< 0.000324	NA
Zinc	mg/l	< 0.004	0.0144	NA
Phenol Index	mg/l	< 0.0497	< 0.0493	NA

Source: [93, Italy 2015]

Parasitic power consumption ranges from 50 kWh to 110 kWh per tonne of waste (corresponding to 10–20 % of recovered gross power production).

Cross-media effects

None reported.

Technical considerations relevant to applicability

Generally applicable.

Economics

Investment cost: EUR 25–30 million.

Operating cost: EUR 5.5 million per year (for a 15 MW_{th} plant, with a nominal capacity of 80 000 tonnes/year of municipal solid waste, corresponding to an operating cost of EUR 68.75 per tonne).

The possible savings are calculated considering a reference value of 0.26 m³/tonne of waste treated, which is the sum of sludge and waste water produced. Considering 80 000 tonnes per year of input waste, the general disposal cost for waste water and sludge is estimated at EUR 1 456 000 per year.

Fixing the amount of waste to process (80 000 tonnes per year) and a disposal cost equivalent to EUR 70 per tonne of waste, the following possible savings were estimated:

- Waste water: EUR 410 000 per year.
- Waste water production for a 15 MW_{th} plant is 1 300 tonnes per year and is equivalent to 0.016 m³/tonne of waste processed. Consequently, the disposal costs per year for waste water are EUR 91 000 per year and the estimated savings are EUR 410 000 per year.
- Sludge: EUR 790 000 per year.
- Sludge production for a 15 MW_{th} plant is 2 600 tonnes per year and is equivalent to 0.032 m³/tonne of waste processed. Consequently, the disposal costs per year for sludge are EUR 182 000 per year and the estimated savings are EUR 790 000 per year.
- Cooling water.
- In contrast to traditional incinerators, this process does not use cooling water.
- Net energy production: EUR 2.2–3.5 per year.
- The net energy production is 31 000 MWh/yr, equivalent to 0.39 MW/tonne of waste processed.

Driving force for implementation

No information provided.

Example plants

Isotherm Gioia del Colle (IT).

Reference literature

[93, Italy 2015]

6.4 Phosphorus recovery from sewage sludge incineration ashes

Description

Recovery of the phosphorus (and other resources) contained in the ashes originating from fluidised bed incineration of municipal sewage sludge.

Technical description

[150, Huygens et al. 2019]

Different techniques have been recently developed and piloted to recover the phosphorus contained in the ashes from the mono-incineration of municipal sewage sludge. These processes may also allow the recovery of additional resources contained in the ashes.

Among the process types, wet-chemical processes and thermal processes may be distinguished. While thermal processes are still generally at the piloting phase at the time of writing this document, some wet-chemical processes are approaching the stage of market entry.

Wet-chemical processes

The phosphorus content is almost completely dissolved by acidification. This process is unavoidably accompanied by a partial dissolution of the metals contained in the ashes. The species and amount of dissolved metals depends on the composition of the raw input material (Fe- or Al-rich) as well as on the type and amount of the added acid (H_2SO_4 or HCl).

Some processes effectively separate and remove toxic inorganic contaminants (e.g. Pb, Cd, Hg, etc.) in order to increase the quality of the phosphorus-rich recovered product. Additionally, the separation of especially Al and Fe as well may be carried out, as these elements can reduce the quality and plant bio-availability of the recovery product. Cations may be removed from the acidic leachate through different approaches, including sequential precipitation, liquid-liquid extraction, and ion exchange.

Depending on the specific process, phosphorus may be recovered as phosphoric acid or directly as mineral P-fertilisers such as dicalcium phosphate (DCP).

Some processes also rely on the partial direct replacement of ground phosphate rock (up to about 10-20% of the total P-content) by P-rich ashes in the acidulation process applied by the fertilisers industry. [147, Langeveld and Ten Wolde 2014]

Thermal processes

Nutrients can be recovered from ashes by high temperature treatments. Processes were developed that transfer P into a metallurgical slag by reductive smelting at very high temperature in a shaft furnace [148, Scheidig 2009] or that reduce P to elemental P that is separated via the gas phase in an inductively heated shaft furnace [149, Schönberg et al. 2014]. The general principle is that volatile heavy metals such as Zn, Pb, Cd and Hg are separated from the product via the gas phase and further collected in the flue dust, and heavy metals with high boiling points such as Fe, Cu, Ni and Cr are separated in the form of a liquid alloy.

Achieved environmental benefits

Benefits include the reduction of the amount of waste for disposal, recovery of saleable phosphorus products, production of precipitation chemicals that can be recycled to waste water treatment plants, detoxification of the ashes by separation of heavy metals as chemically stable sulphides.

Environmental performance and operational data

The reported range of P-recovery ranges between 60 % and 98 % for wet-chemical processes and between 80 % and 98 % for thermal processes.

Cross-media effects

No information provided.

Technical considerations relevant to applicability

No information provided.

Economics

No information provided.

Driving force for implementation

Increasing resource efficiency.

Example plants

Wet-chemical processes have been tested in pilot plants in Sweden, Germany and the Netherlands.

Thermal processes have been piloted in Europe and in Japan.

Reference literature

[138, Bezak-Mazur et al. 2014], [140, Biswas et al. 2009], [141, Egle et al. 2016], [142, Amann et al. 2018], [143, Healy et al. 2015], [145, Easymining 2019], [146, Phos4you 2019], [147, Langeveld and Ten Wolde 2014], [148, Scheidig 2009], [149, Schönberg et al. 2014]

7 CONCLUDING REMARKS AND RECOMMENDATIONS FOR FUTURE WORK

Timing of the review process

The key milestones of the review process are summarised in Table 7.1 below.

Table 7.1: Key milestones of the WI BREF review process

Key milestone	Date
Reactivation of the TWG	12 May 2014
Call for initial positions	20 June 2014
Kick-off meeting	19 to 22 January 2015
Drawing up of questionnaires	April to December 2015
Information and data collection	March 2015 to April 2016
Draft 1 of the revised WI BREF	May 2017
End of commenting period on Draft 1 (2901 comments received)	8 September 2017
Final TWG meeting	23 to 27 April 2018

During the BREF review process, a total of 13 waste incineration plants and 4 incineration bottom ash treatment plants were visited in Austria, France, Germany and Sweden, in 2016 and in 2017.

In addition, two events were organised to improve the exchange of information:

- a webinar in November 2016 on the data collected via the questionnaires (see below);
- an informal TWG meeting in December 2017 for an exchange of views on some key aspects of the WI BREF review in advance of the final TWG meeting.

Sources of information and information gaps

The main sources of information for the review process were:

- scientific and technical literature;
- more than 300 filled-in questionnaires from operators of waste incineration and incineration bottom ash treatment plants;
- additional information from the TWG members;
- about 2 900 comments on Draft 1 of the revised BREF;
- information gathered from site visits;
- outcomes of the workshop and the webinar mentioned above;
- contributions provided by the three thematic subgroups (see below).

During the Kick-off meeting, it was decided to create three thematic TWG subgroups to support the review of the WI BREF on the following issues:

- data collection and questionnaire development;
- energy;
- residues.

In total, more than 400 documents have been posted in BATIS, and most of them have been referenced in the revised WI BREF.

For emissions to air of dust, HCl, HF, CO, TVOC, SO₂, metals and metalloids including mercury, NH₃, as well as PCDD/F and dioxin-like PCBs, the TWG highlighted the potential difficulty, at the time when the Waste Incineration BREF was under review, of assessing compliance with emission limit values when these are set around the lower end of the BAT-AEL ranges, due to the likely increase of the relative measurement uncertainty (i.e. the uncertainty expressed as a percentage of the measured value) with decreasing emission levels.

In this context, the TWG recognised the ongoing CEN work to review and update measurement standards that are relevant for the implementation of the BAT conclusions for Waste Incineration.

Degree of consensus reached during the information exchange

At the final TWG meeting in April 2018, a high degree of consensus was reached on most of the BAT conclusions. However, 16 split views were expressed (on 9 out of a total of 35 BAT conclusions), which fulfil the conditions set out in Section 4.6.2.3.2 of Commission Implementing Decision 2012/119/EU. They are summarised in Table 7.2 below.

Table 7.2: Split views expressed

No	BAT conclusion / table number	Split view	View expressed by	Alternative proposed level (if any)
1	General considerations	Delete the factor $(Q_b/(Q_b-Q_i))$ from the formula to represent the gross electrical efficiency	AT, EEB	NA
2	BAT 4	Add in footnote ⁽⁵⁾ that mixed municipal waste cannot be regarded as a waste with a proven low and stable mercury content	EEB	NA
3		Set the long-term sampling of PCDD/F and of PCDD/F + dioxin-like PCBs only as an optional alternative to short-term sampling in periodic measurements	DE	NA
4		Delete footnote ⁽⁷⁾ , which allows for the obviation of the long-term sampling of PCDD/F or dioxin-like PCBs	BE	NA
5	BAT 11	Add POPs to the examples of substances periodically monitored at the delivery of municipal solid waste and other non-hazardous waste	SE, EEB	NA
6	Change the following BAT-AELs to take into account the measurement uncertainty:		CEWEP, ESWET, Euroheat&Power, FEAD	
	BAT 25 Table 5.3	dust		10 mg/Nm ³
	BAT 27, BAT 28 Table 5.5	SO ₂ for new plants SO ₂ for existing plants		30 mg/Nm ³ 30–40 mg/Nm ³
	BAT 29 Table 5.6	NH ₃ CO		30 mg/Nm ³ 50 mg/Nm ³
	BAT 30 Table 5.7	TVOC		10 mg/Nm ³
	BAT 31 Table 5.8	Hg (expressed as a daily average and as an average over the sampling period)		50 µg/Nm ³
7	BAT 25 Table 5.3	Change footnote ⁽¹⁾ to: 'For existing plants, the higher end of the BAT-AEL range is 7 mg/Nm ³ until the existing filter is upgraded/rebuilt'	AT	NA

8	BAT 29	Applicability of technique d (SNCR): not applicable to hazardous waste incineration plants with a capacity below 6 t/h where the temperature in the secondary combustion chamber is above 1 000 °C and equipped with a direct quench from at least 1 000 °C to 75/80 °C	HWE, Eurits, FEAD	NA
		Applicability of technique e (SCR): not applicable to hazardous waste incinerators with a capacity below 6 t/h where the gases are at a temperature of 75/80 °C and are saturated with water after a direct quench	HWE, Eurits, FEAD	NA
9	BAT 29 Table 5.6	Decrease the higher end of the NO _x BAT-AEL range	BE, NL, SE, EEB	110 mg/Nm ³ for existing plants (SE) 100 mg/Nm ³ for existing plants (NL, EEB) 100 mg/Nm ³ for new plants (BE, NL, SE, EEB)
		Delete footnote (2)	NL, SE, EEB	NA
		Change footnote (2) to: 'Where SCR is not applicable, the higher end of the BAT-AEL range is 180 mg/Nm ³ until the De-NO _x system is upgraded/rebuilt'	AT	NA
10	BAT 29 Table 5.6	Decrease the higher end of the BAT-AEL range for NH ₃ emissions to air	AT, EEB	5 mg/Nm ³
11	BAT 30 Table 5.7	Decrease the lower end of the BAT-AEL range for TVOC emissions to air	EEB	< 2 mg/Nm ³
12	BAT 30 Table 5.7	Decrease the higher end of the BAT-AEL range for PCDD/F emissions to air measured with long-term sampling	AT, BE, EEB	0.04 ng I-TEQ/Nm ³ for new plants 0.06 ng I-TEQ/Nm ³ for existing plants
		Decrease the higher end of the BAT-AEL range for PCDD/F + dioxin-like PCB emissions to air measured with long-term sampling	AT, BE	0.06 ng I-TEQ/Nm ³ for new plants 0.08 ng I-TEQ/Nm ³ for existing plants
		Delete footnote (2)	BE	NA
13	BAT 31 Table 5.8	Set a BAT AEL for Hg emissions to air expressed as a yearly average	EEB	NA
		Remove the half-hourly indicative emission levels and set a BAT AEL for Hg emissions to air expressed as a half-hourly average	EEB	NA
14	BAT 34 Tables 5.9 and 5.10	Increase the higher end of the BAT-AEL range for Ni	CEWEP, ESWET, FEAD, Eurits, HWE and Cefic	0.5 mg/l
15	BAT 34 Tables 5.9 and 5.10	Decrease the higher end of the BAT-AEL ranges for Cd, Hg, Ni and Sb emissions to water	EEB	Cd: 0.01 mg/l Hg: 0.003 mg/l Ni: 0.1 mg/l
			AT	Sb: 0.2 mg/l
16	BAT 35	Amend the BAT statement to: 'BAT is to handle and treat bottom ashes separately from fly ashes and from other FGC residues'	EEB	NA

Consultation of the Forum and subsequent formal adoption procedure of the BAT Conclusions

In accordance with Article 13(3) of the Directive, the Forum gave its opinion on the draft Best Available Techniques (BAT) reference document for Waste Incineration as presented at the meeting of the forum of 27 February 2019:

1. The [Forum welcomed](#) the draft Best Available Techniques (BAT) reference document for Waste Incineration as presented by the Commission.
2. The Forum acknowledged the discussions held at its meeting of 27 February 2019 and agreed that the changes to the draft Best Available Techniques (BAT) reference document for Large Combustion Plants, as proposed in [Annex A of the Forum's opinion](#), should be included in the final document.
3. The forum reaffirmed the comments in [Annex B of the Forum's opinion](#) as representing the views of certain members of the Forum but on which no consensus existed within the Forum to include them in the final document.

Subsequently, the Commission took the opinion of the IED Article 13 Forum into account when preparing the draft Commission Implementing Decision establishing best available techniques (BAT) conclusions for Waste Incineration. The IED Article 75 Committee, at its meeting of 17 June 2019, gave [a positive opinion on this draft Commission Implementing Decision](#).

Subsequently, the Commission Implementing Decision (EU) 2019/7987 establishing best available techniques (BAT) conclusions for Waste Incineration was adopted on 12 November 2019 and published in the Official Journal of the European Union ([OJ L 312, 03.12.2019, p. 55](#)).

Recommendations for future work

The information exchange revealed a number of issues that should be addressed during the next review of the WI BREF. The recommendations for the next review include the following:

- related to the scope of the next WI BREF review:
 - to collect information on the gasification, plasma and pyrolysis plants incinerating waste, in operation in the EU-28;
- related to the boiler efficiency reached by waste incineration plants incinerating hazardous waste or sewage sludge:
 - to collect information on the boiler efficiency and its variation depending for example on the use of auxiliary fuels, or on the type and extent of sludge pre-treatment in the case of the incineration of sewage sludge;
- related to the monitoring method for PCDD/F emissions:
 - to collect information on PCDD/F emissions measured on the basis of short-term versus long-term sampling;
- related to the mixing of different incineration residues for their subsequent treatment:
 - to collect information on the composition of incineration bottom ashes and boiler ashes and on the possible consequences of their mixing on the hazardousness of the resulting material (not only considering the dilution effect) and on the overall material recovery rates.

Suggested topics for future R&D work

The Commission is launching and supporting, through its Research and Technological Development programmes, a series of projects dealing with clean technologies, emerging effluent treatment and recycling technologies and management strategies. Potentially, these projects could provide a useful contribution to future BREF reviews. Readers are therefore invited to inform the European IPPC Bureau of any research results which are relevant to the scope of this document (see also the fifth section of the Preface of this document).

8 ANNEXES

8.1 Costs of some air emissions monitoring systems

Monitoring of PCDD/F and PCBs

Cost data for long-term sampling of PCDD/F and PCBs (from Indaver):

Investment:	EUR 110 000–140 000
Testing of the system:	EUR 4 900 (estimation)
Analysis (26 samples/yr):	EUR 20 000/yr
Maintenance by the supplier (preventive):	EUR 2 500/yr

Monitoring of mercury

Cost data for continuous measurement of mercury (estimated):

Investment:	Around EUR 100 000 per instrument as installed cost
Annual maintenance costs:	EUR 20 000 per line

The investment cost of a long-term sampling system for mercury is considerably cheaper than for continuous measurement, being estimated at around 10–20 % of an AMS. The operating cost is estimated to be approximately the same for the two methods. [[80, Denmark 2015](#)]

8.2 Energy efficiency calculation examples

This annex includes a number of examples of how the energy efficiency of waste incineration plants, or parts thereof, may be calculated in accordance with the concepts used to express the gross electrical efficiency and gross energy efficiency in Section 3.5.1, Section 3.5.2.1, Section 3.5.2.2, and in Chapter 5. The examples mainly cover plants that are part of the 2016 data collection and that incinerate predominantly either non-hazardous wastes other than sewage sludge, or hazardous wood waste.

The subsections below include practical examples of the information used to derive the various terms that are used in the formulas introduced in Section 3.5.1 and in Chapter 5. The last subsection, 8.2.3, provides an example of a more complex case where it may be appropriate to express the energy efficiency in terms of gross electrical efficiency and gross energy efficiency for different parts of the same plant.

8.2.1 Gross electrical efficiency

Case 1.a – Plant generating electricity only

Plant UK03 has only one line, and sends all the steam produced in the boiler to a condensing turbine. No self-consumption of steam is reported by the plant.

The relevant energy efficiency formula (see also Section 3.5.1) is:

$$\eta_e = \frac{W_e}{Q_{th}} \times (Q_b / (Q_b - Q_i))$$

Summary information from the performance test of the plant is as follows in Table 8.1 (the data in italics are given for information purposes but are not strictly necessary for the calculation):

Table 8.1: Summary information from the performance test of an electricity-only plant

Parameter		Related term
Waste input [t/h]	18.36	
Waste input [kg/s]	5.1	
Waste NCV as MJ/kg	8.59	
Total energy input as MW	43.8	Q_{th}
Steam production:		
<i>Temperature [°C]</i>	<i>407.4</i>	
<i>Pressure [bar(a)]</i>	<i>41.1</i>	
<i>Amount [kg/s]</i>	<i>14.2</i>	
<i>Specific output Enthalpy [kJ/kg]</i>	<i>3 229.97</i>	
<i>Specific feed water Enthalpy [kJ/kg]</i>	<i>591.63</i>	
Turbine-generator: Condensing turbine		
<i>Amount [kg/s]</i>	<i>14.2</i>	
<i>Reference temperature of the cooling fluid [°C]</i>	<i>10</i>	
Generator power after correction [MWe]:	10.66	W_e
Gross electrical efficiency [%]:	24.33	

Since no internal steam consumption is reported, it is considered that all the steam produced is sent to the condensing turbine and $Q_i = 0$.

Based on the information above, the relevant terms in the gross electrical efficiency formula are:

$$\begin{aligned} W_e &= 10.66 \text{ MW}_e \\ Q_{th} &= 43.8 \text{ MW} \\ \eta_e &= \mathbf{24.33 \%} \end{aligned}$$

Case 1.b – CHP plant oriented towards the generation of electricity

Plant FR33 has two lines of equal capacity, which send steam to a condensing turbine that has a bleed at a pressure of 4 bar to send steam to a heat exchanger for district heating. However, this bleed can be closed and the steam can be fully expanded in the turbine. The energy efficiency calculation is made therefore at full load with the bleed closed.

Additionally, part of the steam is used internally; this amount is equal to the difference between the steam produced by the boiler and the steam input into the turbine).

The relevant energy efficiency formula (see also Section 3.5.1) is:

$$\eta_e = \frac{W_e}{Q_{th}} \times (Q_b / (Q_b - Q_i))$$

Summary information from the performance test of the plant is as follows in Table 8.2 (the data in italics are given for information purposes but are not strictly necessary for the calculation):

Table 8.2: Summary information from the performance test of an electricity-oriented CHP plant

Parameter	Boiler 1	Boiler 2	Total	Related term
Waste input [t/h]	5.51	5.51	11.02	
Waste input [kg/s]	1.53	1.53	3.06	
Waste NCV as MJ/kg	9.21	9.21		
Total energy input as MW	14.07	14.07	28.14	Q_{th}
Steam production:				
<i>Temperature [°C]</i>	<i>362.7</i>	<i>368.5</i>		
<i>Pressure [bar(a)]</i>	<i>45</i>	<i>44.9</i>		
<i>Amount [kg/s]</i>	<i>4.69</i>	<i>4.67</i>	<i>9.36</i>	
<i>Specific Enthalpy [kJ/kg]</i>	<i>3 113.8</i>	<i>3 128.6</i>		
Turbine-generator: Condensing turbine				
<i>Amount of steam in input [kg/s]</i>			9.17	
Generator power [MWe]:			5.97	W_e
<i>Heat exchangers for district heating: not used in the calculation as the bleed is closed during the performance test</i>				
<i>Pressure [bar(a)]</i>			4	
<i>Nominal power (MWth)</i>			9	
Gross electrical efficiency [%]:			21.65	

Part of the high-pressure steam (0.19 kg/s) is extracted directly from the boiler for internal use (soot blowers) during the performance test. This is related to the term Q_i .

Based on the information above, the relevant terms in the gross electrical efficiency formula are:

$$\begin{aligned}W_e &= 5.97 \text{ MW}_e \\Q_{th} &= 28.14 \text{ MW} \\Q_b &= (9.36) \times \Delta h \\Q_i &= (9.36 - 9.17) \times \Delta h \\ \eta_e &= \mathbf{21.65 \%}\end{aligned}$$

Where Q_i is expressed in this case as the difference between the amount of steam produced and the amount of steam input into the turbine, multiplied by the change in enthalpy (Δh) between the steam and the feed water. The calculation of Δh is not necessary since the term is simplified in the calculation.

8.2.2 Gross energy efficiency

Case 2.a – Plant generating heat only

Plant FR18 below has two lines with a different capacity. As the two boilers were put into operation and tested in different moments, the NCV of the waste is different. They also produce steam at different pressure, since one of the boilers is intended to be connected to a steam turbine in the future. The steam produced is entirely used for direct export (and not sent to a DH network). No self-consumption of heat (Q_i) is reported.

The relevant energy efficiency formula (see also Section 3.5.1) is:

$$\eta_h = \frac{W_e + Q_{he} + Q_{de} + Q_i}{Q_{th}}$$

Summary information from the performance test of the plant is as follows in Table 8.3 (the data in italics are given for information purposes but are not strictly necessary for the calculation):

Table 8.3: Summary information from the performance test of a heat-only plant

Parameter	Boiler 1	Boiler 2	Total	Related term
Waste input [t/h]	3.2	4	7.2	
Waste input [kg/s]	0.89	1.11	2.00	
Waste NCV as MJ/kg	8.17	9.18		
Total energy input as MW	7.27	10.18	17.45	Q_{th}
<i>Steam production:</i>				
<i>Temperature [°C]</i>	220	350		
<i>Pressure [bar(a)]</i>	20	40		
<i>Amount [kg/s]</i>	1.94	3.47	5.42	
<i>Specific Enthalpy [kJ/kg]</i>	2 798.4	2 800.9		
Turbine-generator: none				
Steam / hot water direct export				
Nominal power (nominal thermal power export capacity of direct export point minus nominal thermal power of the return flow [MW _{th}])			13.2	Q_{de}
Gross energy efficiency [%]:			75.6%	

Based on the information above, the relevant terms in the gross energy efficiency formula are:

$$\begin{aligned}
 W_e &= 0 \text{ (no turbine)} \\
 Q_{de} &= 13.2 \text{ MW} \\
 Q_{he} &= 0 \text{ (no heat exchanger for DH)} \\
 Q_i &= 0 \text{ (no internal use of heat is reported)} \\
 Q_{th} &= 17.45 \text{ MW} \\
 \eta_h &= 75.6 \%
 \end{aligned}$$

Case 2.b – CHP plant oriented towards the generation of heat

Plant FR53 has two lines of equal capacity, which send steam to a back-pressure turbine and then send steam at a pressure of 1.7 bar to a heat exchanger for district heating.

The relevant energy efficiency formula (see also Section 3.5.1) is:

$$\eta_h = \frac{W_e + Q_{he} + Q_{de} + Q_i}{Q_{th}}$$

Summary information from the performance test of the plant is as follows in Table 8.4 (the data in italics are given for information purposes but are not strictly necessary for the calculation):

Table 8.4: Summary information from the performance test of a heat-oriented CHP plant

Parameter	Boiler 1	Boiler 2	Total	Related term
Waste input [t/h]	7.5	7.5	15	
Waste input [kg/s]	2.08	2.08	4.16	
Waste NCV as MJ/kg	8.36	8.36		
Total energy input as MW			34.85	Q_{th}
<i>Steam production:</i>				
Temperature [°C]			410	
Pressure [bar(a)]			40.6	
Amount [kg/s]	5.67	5.67	11.34	
Specific Enthalpy [kJ/kg]			3236.94	
Turbine-generator: Backpressure turbine				
Amount [kg/s]			10.56	
Generator power [MWe]:			5.8	W_e
Heat exchanger				
Pressure [bar(a)]			1.7	
Nominal power			26.2	Q_{he}
Gross energy efficiency [%]:			91.82	

Based on the information above, the relevant terms in the gross energy efficiency formula are:

$$W_e = 5.8 \text{ MW}$$

$$Q_{de} = 0 \text{ (no direct export point)}$$

$$Q_{he} = 26.2 \text{ MW}$$

$$Q_i = 0 \text{ (no internal use of heat is reported)}$$

$$Q_{th} = 34.85 \text{ MW}$$

$$\eta_h = \mathbf{91.82 \%}$$

8.2.3 Intermediate cases: gross electrical efficiency and gross energy efficiency determined jointly

Case 3 – Virtual separation of a plant in two parts, one generating electricity only, the other one generating heat and power

This Section describes an Energy from Waste Facility operated by Viridor in Runcorn (UK). This plant is composed of two incineration lines (and boilers) feeding into a condensing turbine divided into a high-pressure (HP) and a low-pressure (LP) section, but cannot expand all the steam in the LP turbine since it is designed for a lower steam capacity, while the remaining part of the steam, at around 15 bar, is exported to a nearby industry.

As the efficiency of this plant cannot therefore be entirely calculated through either the gross electrical efficiency or the gross energy efficiency formula, the solution worked out below consists in split the steam flow in the following two parts; the energy efficiency is then calculated separately for these two parts of the plant:

- The first part of the plant corresponds to the amount of steam that is then exported to the industry. This steam pass only through the HP turbine, which so generates power between the inlet pressure and the pressure at which the steam is exported. The HP turbine is considered as a virtual back-pressure (BP) turbine, and the power it generates is added to the power of the steam exported in the gross energy efficiency formula used for this part of the plant.
- The second part of the plant corresponds to the amount of steam that can pass through both sections of the turbine, limited by the steam capacity that can be expanded in the LP turbine. The efficiency of this part of the plant is determined through the gross electrical efficiency formula.

Figure 8.1 shows a schematic diagram of this separation. Summary information from the performance test of the plant follow in Table 8.5

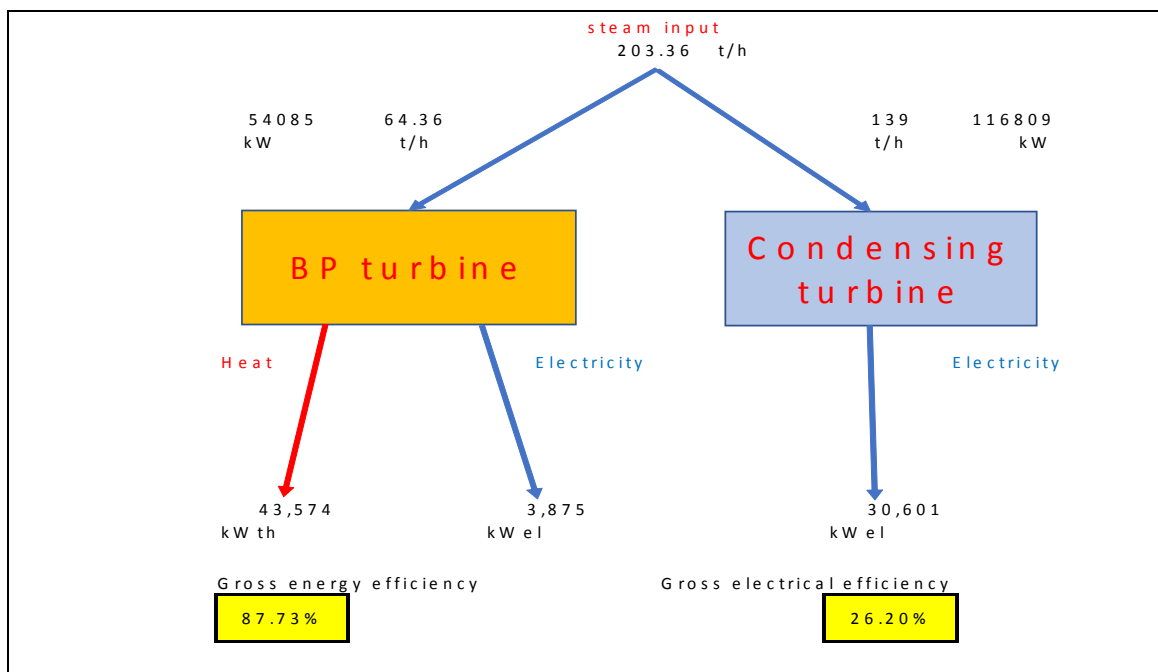

Figure 8.1: Schematic diagram of the separation of the steam system of the waste incineration plant in two parts

Table 8.5: Summary information from the performance test of a plant with a hybrid configuration

#	Parameter	Boiler 1	Boiler 2	Total
A	Waste input [t/h]	24.72	25.18	49.90
B	Waste input [kg/s]	6.87	6.99	13.86
C	Waste NCV as MJ/kg	12.33	12.33	
D	Total energy input as MW	84.652	86.242	170.894
E	Steam production [t/h]	100.41	102.95	203.36
F	Temperature [°C]	399.99	400.06	
G	Pressure [bar(a)]	53.1	53.2	
H	Specific Enthalpy	3190.9	3191.0	
I	Enthalpy of water input [kJ/kg]	454.8	455.2	
Turbine: Condensing turbine				
J	Gross Power Output [MW]:			33.745
K	Gross Power Output (after correction) [MW]:			34.476
Steam export				
L	Amount [kg/s]			64.36
M	Temperature [°C]			236.5
N	Pressure [bar(a)]			14.863
O	Specific Enthalpy [kJ/kg]			2892.1

Based on these parameters, Table 8.6 and Table 8.7 report a summary of the calculation of the gross energy efficiency and gross electrical efficiency calculated for the respective parts of the waste incineration plant. [144, Energy subgroup 2019]

Table 8.6: Summary calculation of the gross energy efficiency of the part of the plant described as a virtual heat-oriented CHP plant

Virtual heat-oriented CHP plant				
#	Parameter	Value	Determined as	Related term
P	Steam flow to industrial user [t/h]	64.36	= Performance test	
Q	Total Energy input [MW]	54.085	= D * P / E	Q_{th}
R	Thermal power output [MW _{th}]	43.574	= P * (O-I) / 3.6	Q_{de}
S	Enthalpy after HP turbine	2956.7	Performance test	
T	Power production [MW _{el}]	4.189	= P * (H-S)	W_e
$\eta_h = \frac{W_e + Q_{he} + Q_{de} + Q_i}{Q_{th}} = 88.31\% \quad Q_i=0, Q_{he}=0$				

Table 8.7: Summary calculation of the gross electrical efficiency of the part of the plant described as a virtual electricity-only plant

Virtual electricity-only plant				
#	Parameter	Value	Determined as	Related term
U	Steam flow to the turbine [t/h]	139	= E - P	
V	Total Energy input [MW]	116.809	= D * U / E	Q_{th}
W	Pressure at the condenser [bar]	0.072	Performance test	
Y	Power output [MW]	30.287	= K - T	W_e
$\eta_e = \frac{W_e}{Q_{th}} \times \left(\frac{Q_b}{Q_b - Q_i} \right) = 25.93\% \quad Q_i=0$				

8.3 Example of a multi-criteria assessment used for the selection of FGC systems

The tables below provide an example of how, in an actual project for an incineration plant with a capacity of 200 000 tonnes of waste (tw) per year, the assessment and selection of a FGC system was carried out.

Table 8.8: Example of a multi-criteria assessment of FGC system selection

Criteria				
Process		Semi-wet	Dry double filtration	Dry simple filtration
1- NATURAL RESOURCES CONSERVATION & EFFICIENCY				
a- raw material				
water	m ³ /tw	0.2	-	-
reagents				
type		lime	bicarb	bicarb
quantity		18	26	26
type 2 (ammonia)	kg/tw	5	5	5
type 3 (activated carbon)	kg/tw	0.6	0.6	0.6
energy consumption	kg/tw			
auxiliary fuel		-	-	-
electricity		25	30	20
b- recovery & recycling	kg/tw			
energy recovery				
metal recovery	kg/tw			
construction material recovery				
salts recovery		-	possible	-
2- EMISSIONS				
a- low-waste techniques				
liquid effluents				
solid residues				
FGC residues quantity				
Fly ashes				
Salts		-	-	-
FGC/salts residues quality		54	-	45
b- emissions and impact	kg/tw	-	25	-
emissions to atmosphere		-	20	-
pollutants		calcic	sodic	sodic
noise				
odours				
emissions to water				
emissions via residues				
3- RISKS				
risks from hazardous substances (chemicals)		little	none	none
risks from emissions		negligible	negligible	negligible
risks from accidents				
4- ECONOMICS				
costs and benefits fixed cost (investment and maintenance)	EUR	4.1	5.1	3.9
operating costs		19.9	19.7	20.6
TOTAL COST		24.0	24.8	24.5

Table 8.9: Example of a multi-criteria cost assessment used for comparing FGC system options

200 000 t _w /yr								
Process Reagent(s)		Semi-wet Lime		Dry double filtration Bicarb		Dry simple filtration Bicarb		
I) Variables costs:								
<u>Reagents:</u>	Unit (u)	Cost (€/u)	Quant. (u/t _w)	Cost (€/t _w)	Quant. (u/t _w)	Cost (€/t _w)	Quant. (u/t _w)	Cost (€/t _w)
Lime	kg	0.1	18	1.8				
Sodium bicarbonate	kg	0.2			26	5.2	26	5.2
Ammonia	kg	0.15	5	0.8	5	0.8	5	0.8
Activated carbon	kg	1.5	0.6	0.9	0.6	0.9	0.6	0.9
<u>Utilities:</u>								
Water	m ³	0.5	0.2	0.1				
Electricity	kWh	0.04	25	1.0	30	1.2	20	0.8
1- Total reagents and utilities		€/t_w		4.6		8.1		7.7
<u>Residues and effluents:</u>								
Fly ashes	kg	0.27			25	6.8		
FGC residues	kg	0.27	54	14.6	20	4.0	45	12.2
Salts	kg	0.20						
2- Total residues and effluents		€/t_w		14.6		10.8		12.2
TOTAL 1+2		€/t_w		19.2		18.9		19.9
3- Total workforce								
		€/t_w		0.2		0.2		0.2
4- Total daily maintenance								
		€/t_w		0.5		0.6		0.5
II) Fixed costs:								
5- Provision for mainten. & renewal		€/t_w		1.3		1.6		1.2
6 Annuity (corresp. to the invest. principal + interest)*		€/t_w		2.8		3.5		2.7
Total variable costs 1+2+3+4		€/t_w		19.9		19.7		20.6
Total fixed costs 5+6		€/t_w		4.1		5.1		3.9
TOTAL COST		€/t_w		24		24.8		24.5

* Fixed rate 6 % - duration 20 years.

8.4 List of European waste incineration plants that participated in the 2016 data collection

Reference line	Name of the installation	City	Country	Main activity	Capacity	Prevalent type of waste burnt	Flue-gas cleaning techniques installed
AT01R	MVA Floetzersteig	Vienna	AT	5.2. (a)	27.9 t/h	M	SCR BF WS2s DSI
AT02R	MVA Spittelau	Vienna	AT	5.2. (a)	32 t/h	M	SCR BF WS2s
AT03R	MVA Pfaffenau	Vienna	AT	5.2. (a)	32 t/h	M	SCR ESPd WS2s Bed
AT04.1R	WAV Wels	Wels	AT	5.2. (a)	8 t/h	O	SCR ESPd WS2s Bed
AT04.2R	WAV Wels	Wels	AT	5.2. (a)	28.9 t/h	O	Prim SCR ESPd BF WS2s DSI
AT05.1R	MVA Duernrohr	Zwentendorf	AT	5.2. (a)	150 000 t/yr	M	Prim SCR BF WS2s DS_rcy DSI
AT05.2R	MVA Duernrohr	Zwentendorf	AT	5.2. (a)	150 000 t/yr	M	Prim SCR BF WS2s DS_rcy DSI
AT05.3R	MVA Duernrohr	Zwentendorf	AT	5.2. (a)	225 000 t/yr	M	Prim SCR BF WS2s DS_rcy DSI
AT06R	TBA Arnoldstein	Arnoldstein	AT	5.2. (a)	96 000 t/yr	M	SCR BF Bed sWS Other
AT07R	MVA Zistersdorf	Zistersdorf	AT	5.2. (a)	19.8 t/h	M	SCR BF DS_rea
AT08.1R	Simmeringer Haide	Vienna	AT	5.2. (a)	30 t/h	S	SCR ESPd WS2s Bed
AT08.2R	Simmeringer Haide	Vienna	AT	5.2. (a)	16.2 t/h	M	SCR ESPd WS2s Bed
AT09R	RVL Lenzing	Lenzing	AT	5.2. (a)	37 t/h	O	SCR BF Cyc WS2s DSI
AT11R	RHKW Linz-Mitte	Linz	AT	5.2. (a)	28 t/h	M	SCR BF Cyc WS2s DSI
BE01R	BIONERGA VERBRANDING	Houthalen-Helchteren	BE	5.2. (a)	6.1 t/h	M	SCR ESPd Cyc sWS DS_rea DSI

Reference line	Name of the installation	City	Country	Main activity	Capacity	Prevalent type of waste burnt	Flue-gas cleaning techniques installed
BE02R	Brussel-Energie	Brussels	BE	5.2. (a)	75 t/h	M	SCR ESPd ESPw WS2s
BE03R	IMOG	Harelbeke	BE	5.2. (a)	8 t/h	M	SCR ESPd BF WS2s DSI
BE04.1	Intradel-Uvelia	Herstal	BE	5.2. (a)	67.08 MW	M	SCR ESPd BF sWS DSI
BE04.2	Intradel-Uvelia	Herstal	BE	5.2. (a)	67.08 MW	M	SCR ESPd BF sWS DSI
BE05R	Ipalle	Beloeil	BE	5.2. (a)	51.94 t/h	O	SNCR ESPd BF WS2s sWS DSI Qch
BE06R	Biostoom Oostende nv	Ostend	BE	5.2. (a)	31.25 t/h	O	SNCR BF Qch
BE07R	Grate furnace Indaver	Beveren	BE	5.2. (a)	50 t/h	M	SNCR BF WS2s DS_rea DSI
BE08.1R	Sleco	Beveren	BE	5.2. (a)	71 t/h	O	SNCR ESPd BF WS1s DS_rcy DSI
BE08.2R	Sleco	Beveren	BE	5.2. (a)	71 t/h	O	SNCR ESPd BF WS1s DS_rcy DSI
BE08.3R	Sleco	Beveren	BE	5.2. (a)	71 t/h	O	SNCR ESPd BF WS1s DS_rcy DSI
BE09.1R	Rotary Kiln Indaver	Antwerp	BE	5.2. (a)	16.67 t/h	H	SNCR ESPd WS2s Bed
BE09.2R	Rotary Kiln Indaver	Antwerp	BE	5.2. (a)	16.67 t/h	H	SNCR ESPd WS2s Bed
BE09.3R	Rotary Kiln Indaver	Antwerp	BE	5.2. (a)	16.67 t/h	H	SNCR ESPd WS2s Bed
BE10R	ISVAG	Antwerp	BE	5.2. (a)	8.5 t/h	M	Prim SNCR ESPd BF WS1s WS2s sWS Bed Qch
BE12	MIROM	Roeselare	BE	5.2. (a)	4 t/h	M	SCR ESPd DSI

Reference line	Name of the installation	City	Country	Main activity	Capacity	Prevalent type of waste burnt	Flue-gas cleaning techniques installed
BE13	IVBO	Bruges	BE	5.2. (a)	200 000 t/yr	M	Prim SCR WS2s DSI Qch
BE14	IVM	Eeklo	BE	5.2. (b)	95 152 t/yr	M	SCR ESPd sWS DS_rcy
CZ01.1R	Waste to Energy Plant SAKO Brno, a.s.	Brno	CZ	5.2. (a)	32	M	SNCR sWS DSI
CZ01.2R	Waste to Energy Plant SAKO Brno, a.s.	Brno	CZ	5.2. (a)	32	M	SNCR sWS DSI
DE01	Danpower Biomassekraftwerk	Delitzsch	DE	5.2. (a)	163 000 t/yr	O	SNCR BF Cyc
DE02	Heizkraftwerk Altstadt	Altstadt	DE	5.2. (a)	104 000 t/yr	O	Prim BF DSI
DE03	biotherm Hagenow GmbH	Hagenow	DE	5.2. (a)	67 765 t/yr	O	BF Cyc
DE04	Biomasseheizkraftwerk Zolling GmbH	Zolling	DE	5.2. (b)	21 0240 t	H	SNCR BF Cyc DS_rea
DE05	BHZ Zapfendorf	Zapfendorf	DE	5.2. (a)	60 000 t/yr	H	SCR BF DSI
DE15.1R	Sewage Sludge Incineration BASF SE	Ludwigshafen	DE	5.2. (b)	200 000 t/yr	S	ESPd BF WS3s DSI
DE15.2R	Sewage Sludge Incineration BASF SE	Ludwigshafen	DE	5.2. (b)	200 000 t/yr	S	ESPd BF WS3s DSI
DE16R	INNOVATHERM GmbH	Lünen	DE	5.2. (a)	265 000 t/yr	S	ESPd BF WS2s DSI Qch
DE17R	Currenta	Dormagen	DE	5.2. (a)	65 000 t/yr	H	Prim SCR ESPw WS3s
DE18.1	GSB Ebenhausen	Baar-Ebenhausen bei Ingolstadt	DE	5.2. (a)	105 000 t/yr	H	SNCR ESPd BF WS3s DSI Bed
DE18.2	GSB Ebenhausen	Baar-Ebenhausen bei Ingolstadt	DE	5.2. (a)	105 000 t/yr	H	SNCR ESPd BF WS3s DSI Bed
DE19R	AGV	Trostberg	DE	5.2. (a)	30 t/d	H	SCR WS2s Qch
DE20.1R	Wacker Chemie AG, Burghausen	Burghausen	DE	4	16 000 Nm ³ /h	H	SCR ESPw WS1s WS2s PC Qch

Reference line	Name of the installation	City	Country	Main activity	Capacity	Prevalent type of waste burnt	Flue-gas cleaning techniques installed
DE20.2R	Wacker Chemie AG, Burghausen	Burghausen	DE	4	26 000 Nm ³ /h	H	SCR ESPw WS1s WS2s PC Qch
DE21.1R	Wacker Chemie AG, Nünchritz	Nünchritz	DE	4	37 000 t/yr	H	ESPw WS3s Bed Qch
DE21.2R	Wacker Chemie AG, Nünchritz	Nünchritz	DE	4	37 000 t/yr	H	ESPw Cyc WS3s Bed Qch
DE22R	Drehrohrofenanlage Schkopau	Schkopau	DE	5.2. (a)	124 t/d	H	ESPw WS1s Bed Qch
DE23R	Reststoffverwertungsanlage (RVA)	Stade	DE	5.2. (b)	150 t/d	H	Prim ESPw WS2s Bed Qch
DE24	Chemiepark Marl	Marl	DE	5.2. (a)	17 000 t/yr	H	SNCR BF WS2s Bed
DE25R	TRV Thermische Rückstandsverwertung GmbH & Co KG	Wesseling	DE	5.2. (b)	41 MW _{th}	H	SCR ESPd WS2s Bed
DE26.1R	BASF Ludwigshafen	Ludwigshafen	DE	5.2. (b)	23 t/h	H	SCR ESPd WS3s Qch
DE26.2R	BASF Ludwigshafen	Ludwigshafen	DE	5.2. (b)	23 t/h	H	SCR ESPd WS3s Qch
DE26.3R	BASF Ludwigshafen	Ludwigshafen	DE	5.2. (b)	23 t/h	H	SCR ESPd WS3s Qch
DE27.1	InfraServ Höchst	Frankfurt	DE	5.2. (a)	NI	NI	NI
DE27.2	InfraServ Höchst	Frankfurt	DE	5.2. (a)	NI	NI	NI
DE28	Sonderabfallverbrennungsanlage Brunsbüttel	Brunsbüttel	DE	5.2. (a)	55 000 t/yr	H	SCR ESPd BF WS3s DSI PC
DE29.1R	SAV Biebesheim	Biebesheim	DE	5.2. (b)	35 MW	H	SNCR ESPd BF WS3s DSI PC Qch
DE29.2R	SAV Biebesheim	Biebesheim	DE	5.2. (b)	35 MW	H	SNCR ESPd BF WS3s DSI PC Qch
DE30.1R	SAV Hamburg	Hamburg	DE	5.2. (b)	130 000 t/yr	H	SCR ESPd WS2s Bed PC Qch

Reference line	Name of the installation	City	Country	Main activity	Capacity	Prevalent type of waste burnt	Flue-gas cleaning techniques installed
DE30.2R	SAV Hamburg	Hamburg	DE	5.2. (b)	69.4 MW	H	SCR ESPd WS2s Bed PC Qch
DE31R	BMHKW Flohr	Neuwied	DE	5.2. (b)	30.2 MW _{th}	H	Prim SNCR BF Cyc sWS
DE32R	BMK Biomassekraftwerk Lünen GmbH	Lünen	DE	5.2. (b)	68.4 MW _{th}	H	Prim SNCR BF Cyc sWS
DE33R	BMHKW Buchen	Buchen / Odenwald	DE	5.2. (b)	29.7 MW _{th}	H	Prim SNCR BF Cyc sWS
DE34	AVA	Augsburg	DE	5.2. (a)	240 000 t/yr	M	SCR ESPd WS2s DSI
DE35R	MHKW	Berlin	DE	5.2. (a)	88.2 t/hr	M	SCR BF DSI
DE36.1R	PD energy GmbH	Bitterfeld-Wolfen	DE	5.3. (a)	134 400 t/yr	O	SNCR BF DS _{rcy}
DE36.2R	PD energy GmbH	Bitterfeld-Wolfen	DE	5.3. (a)	134 400 t/yr	O	SNCR BF DS _{rcy}
DE37R	TREA Breisgau	Eschbach	DE	5.2. (a)	22 t/h	M	SCR ESPd WS2s DSI Bed
DE38	Müllheizkraftwerk Bremen	Bremen	DE	5.2. (a)	580 000 t/yr	M	SNCR ESPd BF sWS DS _{rcy} DSI
DE39.1	MHKW Bremerhaven	Bremerhaven	DE	5.2. (a)	401 500 t/yr	M	SNCR ESPd BF WS2s DSI
DE39.2	MHKW Bremerhaven	Bremerhaven	DE	5.2. (a)	401 500 t/yr	M	SNCR ESPd BF WS2s DSI
DE39.3	MHKW Bremerhaven	Bremerhaven	DE	5.2. (a)	401 500 t/yr	M	SNCR ESPd BF WS2s DSI
DE40.1	Müllheizkraftwerk Burgkirchen	Burgkirchen	DE	5.2. (a)	230 000 t/yr	M	SCR ESPd BF WS3s DSI
DE40.2	Müllheizkraftwerk Burgkirchen	Burgkirchen	DE	5.2. (a)	230 000 t/yr	M	SCR ESPd BF WS3s DSI
DE41.1R	Müllheizkraftwerk Darmstadt	Darmstadt	DE	5.2. (a)	217 000 t/yr	M	SCR ESPd WS3s
DE41.2R	Müllheizkraftwerk Darmstadt	Darmstadt	DE	5.2. (a)	217 000 t/yr	M	SCR ESPd WS3s
DE41.3R	Müllheizkraftwerk Darmstadt	Darmstadt	DE	5.2. (a)	217 000 t/yr	M	SCR ESPd WS3s

Reference line	Name of the installation	City	Country	Main activity	Capacity	Prevalent type of waste burnt	Flue-gas cleaning techniques installed
DE42R	Müllverbrennungsanlage Düsseldorf	Düsseldorf	DE	5.2. (a)	75 t/h	M	SCR ESPd sWS DSI Bed
DE43R	Waste incineration plant Karnap	Essen	DE	5.2. (a)	180 237 t/yr	M	SCR ESPd WS1s Bed
DE44R	MHKW - Frankfurt	Frankfurt Main	DE	5.2. (a)	525 600 t/yr	M	SNCR BF DSI
DE45R	Müllheizkraftwerk Göppingen	Göppingen	DE	5.2. (a)	19.8 t/h	M	SCR BF WS1s WS2s DSI Qch
DE46R	EEW Energy from Waste Großräschen GmbH	Großräschen	DE	5.2. (a)	28.6 t/h	O	SNCR BF DSI
DE47.1R	MVB Müllverwertung Borsigstraße GmbH	Hamburg	DE	5.2. (a)	320 000 t/yr	M	SNCR BF WS3s DSI
DE47.2R	MVB Müllverwertung Borsigstraße GmbH	Hamburg	DE	5.2. (a)	320 000 t/yr	M	SNCR BF WS3s DSI
DE48.1	MVR Müllverwertung Rugenberger Damm GmbH & Co. KG	Hamburg	DE	5.2. (a)	320 000 t/yr	M	SNCR BF WS3s
DE48.2	MVR Müllverwertung Rugenberger Damm GmbH & Co. KG	Hamburg	DE	5.2. (a)	320 000 t/yr	M	SNCR BF WS3s
DE49.1R	NA	Hannover	DE	5.2. (a)	28 t/h	M	SNCR BF sWS DSI
DE49.2R	NA	Hannover	DE	5.2. (a)	28 t/h	M	SNCR BF sWS DSI
DE50.1R	ETN Heringen	Heringen / Werra	DE	5.2. (a)	35 t/h	O	SNCR BF sWS DS_rea
DE50.2R	ETN Heringen	Heringen / Werra	DE	5.2. (a)	35 t/h	O	SNCR BF sWS DS_rea
DE51R	Abfallentsorgungszentrum (AEZ) Asdonkshof	Kamp-Lintfort	DE	5.2. (a)	260 000 t/yr	O	SCR ESPd WS1s WS2s Bed Qch
DE52.1	MHKW Kassel	Kassel	DE	5.2. (a)	200 000 t/yr	M	SCR BF DSI Bed
DE52.2	MHKW Kassel	Kassel	DE	5.2. (a)	200 000 t/yr	M	SCR BF DSI Bed

Reference line	Name of the installation	City	Country	Main activity	Capacity	Prevalent type of waste burnt	Flue-gas cleaning techniques installed
DE53.1	Müllverbrennung Kiel	Kiel	DE	5.2. (a)	140 000 t/yr	M	SCR ESPd WS2s WS3s Bed Qch
DE53.2	Müllverbrennung Kiel	Kiel	DE	5.2. (a)	140 000 t/yr	M	SCR ESPd WS2s WS3s Bed Qch
DE54.1	AVG Köln mbH	Cologne	DE	5.2. (a)	780 000 t/yr	O	SCR BF WS1s WS2s Bed
DE54.2	AVG Köln mbH	Cologne	DE	5.2. (a)	780 000 t/yr	O	SCR BF WS1s WS2s Bed
DE54.3	AVG Köln mbH	Cologne	DE	5.2. (a)	780 000 t/yr	O	SCR BF WS1s WS2s Bed
DE54.4	AVG Köln mbH	Cologne	DE	5.2. (a)	780 000 t/yr	O	SCR BF WS1s WS2s Bed
DE55.1R	MKVA Krefeld	Krefeld	DE	5.2. (a)	80.29 t/h	M	SNCR BF WS2s WS3s DSI Qch
DE55.2R	MKVA Krefeld	Krefeld	DE	5.2. (a)	80.29 t/h	M	SNCR BF DSI
DE55.3R	MKVA Krefeld	Krefeld	DE	5.2. (a)	80.29 t/h	M	SCR BF WS2s WS3s DSI Qch
DE56R	Waste incineration plant	Lauta	DE	5.2. (a)	225 000 t/yr	M	SCR BF DS_ry DSI Bed Qch
DE57	MVV TREA Leuna	Leuna	DE	5.2. (a)	400 000 t/yr	O	SNCR BF sWS DS_ry DS_rea DSI Qch
DE58.1R	MHKW Leverkusen	Leverkusen	DE	5.2. (a)	680 t/d	M	SCR ESPd WS2s Bed
DE58.2R	MHKW Leverkusen	Leverkusen	DE	5.2. (a)	680 t/d	M	SCR ESPd WS2s Bed
DE58.3R	MHKW Leverkusen	Leverkusen	DE	5.2. (a)	680 t/d	M	SCR ESPd WS2s Bed
DE59	MHKW Ludwigshafen	Ludwigshafen	DE	5.2. (a)	200 t	M	SCR BF DS_ry Qch
DE60	MHKW Mainz	Mainz	DE	5.2. (a)	NI	O	SNCR BF WS2s DSI

Reference line	Name of the installation	City	Country	Main activity	Capacity	Prevalent type of waste burnt	Flue-gas cleaning techniques installed
DE61R	Abfallheizkraftwerk Neunkirchen	Neunkirchen	DE	5.2. (a)	17 t/h	O	SCR ESPd ESPw BF WS3s Bed
DE62	Müllverbrennungsanlage Nürnberg	Nuremberg	DE	5.2. (a)	105 MW _{th}	M	SCR ESPd WS1s DS_rea
DE63R	GMVA Gemeinschafts-Müll-Verbrennungsanlage Niederrhein GmbH	Oberhausen	DE	5.2. (a)	96 t/h	M	SNCR ESPd BF WS2s DSI
DE64.1R	Müllheizkraftwerk Pirmasens	Pirmasens	DE	5.2. (a)	24 t/h	O	SNCR ESPd BF WS3s
DE64.2R	Müllheizkraftwerk Pirmasens	Pirmasens	DE	5.2. (a)	24 t/h	O	SNCR ESPd BF WS3s
DE65.1	Müllheizkraftwerk Solingen	Solingen	DE	5.2. (a)	53 123 t/yr	O	SNCR ESPd BF sWS DSI
DE65.2	Müllheizkraftwerk Solingen	Solingen	DE	5.2. (a)	53 123 t/yr	O	SNCR ESPd BF sWS DSI
DE66.1	EEW Energy from Waste Stapelfeld GmbH	Stapelfeld	DE	5.2. (a)	350 000 t/yr	M	SCR ESPd WS2s
DE66.2	EEW Energy from Waste Stapelfeld GmbH	Stapelfeld	DE	5.2. (a)	350 000 t/yr	M	SCR ESPd WS2s
DE67.1	REMONDIS Thermische Abfallverwertung GmbH	Staßfurt	DE	5.2. (a)	380 000 t	M	SNCR BF sWS
DE67.2R	REMONDIS Thermische Abfallverwertung GmbH	Staßfurt	DE	5.2. (a)	380 000 t	M	SNCR BF sWS
DE68R	EBS-Kraftwerk Witzenhausen - DSS Paper	Witzenhausen	DE	5.2. (a)	326 000 t/yr	O	SNCR ESPd BF Cyc DS_rcy DSI Qch
DE69	Abfallwirtschaftsgesellschaft mbH Wuppertal	Wuppertal	DE	5.2. (a)	406 933 t/yr	M	SCR ESPd BF DS_rcy DS_rea DSI Bed Qch
DE70	MHKW Würzburg	Würzburg	DE	5.2. (a)	NI	M	SCR BF DS_rcy DSI Qch
DE71.1	Abfallverwertung Zorbau	Lützen	DE	5.2. (a)	107.2 MW _{th}	M	SNCR BF DS_rcy DSI
DE71.2	Abfallverwertung Zorbau	Lützen	DE	5.2. (a)	107.2 MW _{th}	M	SNCR BF DS_rcy DSI
DE72R	IHKW Andernach GmbH	Andernach	DE	5.2. (a)	17.5 t/h	M	SNCR BF DS_rcy

Reference line	Name of the installation	City	Country	Main activity	Capacity	Prevalent type of waste burnt	Flue-gas cleaning techniques installed
DE73R	EEW Stavenhagen GmbH & Co. KG	Stavenhagen	DE	5.2. (a)	11.5 t/h	M	Prim SNCR BF sWS DS_ryc
DE74.1R	MVA Bielefeld-Herford	Bielefeld	DE	5.2. (a)	56.4 t/h	O	SCR ESPd WS2s DSI
DE74.2R	MVA Bielefeld-Herford	Bielefeld	DE	5.2. (a)	56.4 t/h	O	SCR ESPd WS2s DSI
DE74.3R	MVA Bielefeld-Herford	Bielefeld	DE	5.2. (a)	56.4 t/h	O	SCR ESPd WS2s DSI
DE76.1R	MVA Hameln	Hameln	DE	5.2. (a)	50.2 t/h	O	SNCR SCR ESPd DS_ryc Bed Qch
DE76.2R	MVA Hameln	Hameln	DE	5.2. (a)	50.2 t/h	NI	SNCR SCR ESPd DS_ryc Bed
DE76.3R	MVA Hameln	Hameln	DE	5.2. (a)	50.2 t/h	O	SNCR SCR ESPd DS_ryc Bed Qch
DE76.4R	MVA Hameln	Hameln	DE	5.2. (a)	50.2 t/h	O	SCR BF DS_rea
DE78R	Siedlungsmüllverbrennungsanlage (Linien 1 bis 4)	Herten	DE	5.2. (a)	600 000 t/yr	O	SCR ESPd BF WS2s Bed
DE80.1R	Zweckverband MVA Ingolstadt Ersatzverbrennungslinie I	Ingolstadt	DE	5.2. (a)	34 t/h	M	Prim SCR BF WS3s DSI
DE80.2R	Zweckverband MVA Ingolstadt Ersatzverbrennungslinie I	Ingolstadt	DE	5.2. (a)	34 t/h	M	Prim SCR BF WS3s DSI
DE80.3R	Zweckverband MVA Ingolstadt Ersatzverbrennungslinie I	Ingolstadt	DE	5.2. (a)	34 t/h	M	Prim SCR ESPd BF WS3s DSI
DE84R	NA	Rüdersdorf	DE	5.2. (a)	36.8 t/h	M	SNCR BF sWS DSI Bed
DE86R	4.BimSchV Anhang 1 unter 8.1 Müllverbrennungsanlage	Iserlohn	DE	5.2. (a)	295 000 t/yr	M	SCR ESPd BF WS2s DS_rea
DE87.1R	Klärwerk Ruhleben - Klärschlammverbrennungsanlage	Berlin	DE	5.1. (a)	43 t/h	S	ESPd WS1s
DE87.2R	Klärwerk Ruhleben - Klärschlammverbrennungsanlage	Berlin	DE	5.1. (a)	43 t/h	S	ESPd WS1s
DE87.3R	Klärwerk Ruhleben - Klärschlammverbrennungsanlage	Berlin	DE	5.1. (a)	43 t/h	S	ESPd WS1s
DE89R	Restmüllheizkraftwerk Stuttgart Münster	Stuttgart	DE	5.2. (a)	420 000 t/yr	M	SCR ESPd WS3s Qch

Reference line	Name of the installation	City	Country	Main activity	Capacity	Prevalent type of waste burnt	Flue-gas cleaning techniques installed
DK01R	I/S Reno-Nord WTE plant	Aalborg	DK	5.2. (a)	161 500 t/yr	M	SNCR Cyc WS3s
DK02.1R	Incineration of household and industrial waste	Glostrup	DK	5.2. (a)	32 t/h	O	SNCR ESPd BF WS2s DSI Other
DK02.2R	Incineration of household and industrial waste	Glostrup	DK	5.2. (a)	37.4 t/h	M	SNCR BF WS2s DSI
DK03R	Slagelse Forbrændings Anlæg	Slagelse	DK	5.2. (a)	50 000 t/yr	M	SNCR BF Cyc DS_rcy DSI
DK04R	I/S REFA	Nykøbing Falster	DK	5.2. (a)	22 000 t/yr	O	SNCR BF DS_rcy DSI
DK05R	EKOKEM	Nyborg	DK	5.2. (b)	64 000 t/yr	H	SNCR ESPd BF WS3s DSI Qch
DK06R	BIOFOS Lynetten	Copenhagen	DK	5.2. (a)	18 800 t	S	SNCR ESPd BF WS3s DS_rcy DS_rea DSI Qch
ES01.1	TIRMADRID	Madrid	ES	5.2. (a)	300 000 t/yr	M	SCR BF Cyc sWS DSI
ES01.2	TIRMADRID	Madrid	ES	5.2. (a)	300 000 t/yr	M	SCR BF Cyc sWS DSI
ES01.3	TIRMADRID	Madrid	ES	5.2. (a)	300 000 t/yr	M	SCR BF Cyc sWS DSI
ES02.1R	TIRME	Palma de Mallorca	ES	5.2. (a)	91.5 t/h	M	SCR BF sWS DS_rcy DSI
ES02.2R	TIRME	Palma de Mallorca	ES	5.2. (a)	91.5 t/h	M	SCR BF sWS DS_rcy DSI
ES02.3R	TIRME	Palma de Mallorca	ES	5.2. (a)	91.5 t/h	M	SCR BF DS_rcy DS_rea
ES02.4R	TIRME	Palma de Mallorca	ES	5.2. (a)	91.5 t/h	M	SCR BF DS_rcy DS_rea
ES03.1R	SIRUSA	Tarragona	ES	5.2. (a)	9.6 t/h	M	SNCR BF sWS DS_rcy
ES03.2R	SIRUSA	Tarragona	ES	5.2. (a)	9.6 t/h	M	SNCR BF sWS DS_rcy
ES04.1	UTE-TEM	Mataró	ES	5.2. (a)	160 000 t	O	SCR BF sWS DSI
ES04.2	UTE-TEM	Mataró	ES	5.2. (a)	160 000 t	O	SCR BF sWS DSI

Reference line	Name of the installation	City	Country	Main activity	Capacity	Prevalent type of waste burnt	Flue-gas cleaning techniques installed
ES05R	TERSA	Sant Adrià de Besòs (Barcelona)	ES	5.2. (a)	45 t/h	M	SNCR ESPd BF sWS DSI
ES06	TIRCANTABRIA, S.L.U.	Meruelo	ES	5.2. (a)	115 351 t/yr	M	SNCR BF DS_rcy
ES07.1	SOGAMA	Cerceda	ES	5.2. (a)	360 000 t/yr	M	SNCR BF FSI sWS Bed
ES07.2	SOGAMA	Cerceda	ES	5.2. (a)	360 000 t/yr	M	SNCR BF FSI sWS Bed
ES08R	ZABALGARBI	Bilbao	ES	5.2. (a)	30 t/h	M	SNCR BF sWS Bed
ES10R	SAICA PVE	El Burgo de Ebro (Zaragoza)	ES	5.2. (a)	57 t/h	O	Prim SNCR BF Cyc DSI
ES11	SARPI CONSTANTÍ S.L.U.	Constanti-Tarragona	ES	5.2. (a)	8 t/h	H	SCR ESPd WS3s Qch
FI01.1R	Ekokem Oyj	Riihimäki	FI	5.2. (a)	33 t/h	M	Prim SNCR ESPd BF WS2s DSI
FI01.2R	Ekokem Oyj	Riihimäki	FI	5.2. (a)	33 t/h	M	Prim SNCR ESPd BF WS2s DSI
FI01.3R	Ekokem Oyj	Riihimäki	FI	5.2. (a)	33 t/h	M	Prim SNCR BF DS_rea DSI
FI02	Kotka Wte	Kotka	FI	5.2. (a)	102 863 t/yr	M	Prim SNCR BF sWS
FI03	Kymijärvi II	Lahti	FI	5.2. (a)	249 056 t/yr	M	SCR BF DSI
FI04R	Laanila WtE Plant	Oulu	FI	5.2. (a)	150 000 t/yr	M	SNCR BF WS1s DS_rcy DS_rea Qch
FI05	Vantaan Jätevoimala	Vantaa	FI	5.2. (a)	116 MWth	M	SNCR ESPd BF WS1s DS_rea
FI06R	Westenergy Oy Ab	Mustasaari	FI	5.2. (a)	20 t/h	M	SNCR BF DS_rea
FR002R	VITRE	Vitre	FR	5.2. (a)	4 t/h	M	BF DSI
FR003R	Meuse Energie	Tronville en Barrois	FR	5.2. (a)	4 t/h	M	ESPd BF WS2s DSI PC
FR010R	Cluses	Marignier	FR	5.2. (a)	5 t/h	M	SNCR ESPd BF DSI

Reference line	Name of the installation	City	Country	Main activity	Capacity	Prevalent type of waste burnt	Flue-gas cleaning techniques installed
FR012R	Egletons	Rosiers d'Egletons	FR	5.2. (a)	5.3 t/h	M	BF DSI
FR015	Fourchambault	Fourchambault	FR	5.2. (a)	6 t/h	M	SCR BF DSI
FR017	UVE PLUZUNET	Pluzunet	FR	5.2. (a)	7 t/h	O	SCR ESPd WS2s
FR018.1R	SMECO	Pontmain	FR	5.2. (a)	7 t/h	M	SNCR BF DSI Qch
FR018.2R	SMECO	Pontmain	FR	5.2. (a)	7 t/h	M	Prim BF DSI Qch
FR019R	SET Mont Blanc (Passy)	Passy	FR	5.2. (a)	7.5 t/h	M	SNCR BF DSI Qch
FR023R	La Rochelle	La Rochelle	FR	5.2. (a)	8 t/h	M	SNCR BF DSI
FR027R	BAYET	Bayet	FR	5.2. (a)	9 t/h	M	SCR ESPd BF WS1s sWS
FR028R	Montereau-Fault-Yonne	Montereau-Fault-Yonne	FR	5.2. (a)	9 t/h	M	SCR BF DSI
FR029.1R	HAGUENAU	Schweighouse sur Moder	FR	5.2. (a)	10 t/h	M	SNCR BF sWS DSI
FR029.2R	HAGUENAU	Schweighouse sur Moder	FR	5.2. (a)	10 t/h	M	SNCR BF sWS DSI
FR033.1R	ARCANTE	Blois	FR	5.2. (a)	11 t/h	M	SNCR BF WS3s sWS DSI
FR033.2R	ARCANTE	Blois	FR	5.2. (a)	11 t/h	M	SNCR BF WS3s sWS DSI
FR034R	VILLEJUST	Villejust	FR	5.2. (a)	12.9 t/h	M	SCR BF DSI
FR040R	ARQUES	Arques	FR	5.2. (a)	12.5 t/h	M	SCR ESPd BF DSI
FR046.1R	Usine de Fort-De-France	Fort de France	FR	5.2. (a)	14 t/h	M	SNCR BF WS1s WS2s sWS Other
FR046.2R	Usine de Fort-De-France	Fort de France	FR	5.2. (a)	14 t/h	M	SNCR BF WS1s WS2s sWS Other

Reference line	Name of the installation	City	Country	Main activity	Capacity	Prevalent type of waste burnt	Flue-gas cleaning techniques installed
FR052.1R	Limoges	Limoges	FR	5.2. (a)	15 t/h	M	SNCR BF WS1s DSI Qch
FR052.2R	Limoges	Limoges	FR	5.2. (a)	15 t/h	M	SNCR BF WS1s DSI Qch
FR052.3R	Limoges	Limoges	FR	5.2. (a)	15 t/h	M	SNCR BF DSI Qch
FR053R	Ludres	Ludres	FR	5.2. (a)	15 t/h	M	SCR ESPd BF DSI
FR054.1R	ORISANE	Mainvilliers	FR	5.2. (a)	15 t/h	M	SNCR BF sWS DSI
FR054.2R	ORISANE	Mainvilliers	FR	5.2. (a)	15 t/h	M	SNCR BF sWS DSI
FR056.1R	AZALYS	Carrieres sous Poissy	FR	5.2. (a)	15 t/h	M	SCR ESPd Cyc WS2s Qch
FR056.2R	AZALYS	Carrieres sous Poissy	FR	5.2. (a)	15 t/h	M	SCR ESPd Cyc WS2s Qch
FR057.1R	UVE (unité de valorisation énergétique des déchets)	Metz	FR	5.2. (a)	8 t/h	M	SNCR BF DSI
FR057.2R	UVE (unité de valorisation énergétique des déchets)	Metz	FR	5.2. (a)	8 t/h	M	SNCR BF DSI
FR059.1R	OCREAL	Lunel-Viel	FR	5.2. (a)	16 t/h	M	SCR ESPd BF DSI
FR059.2R	OCREAL	Lunel-Viel	FR	5.2. (a)	16 t/h	M	SCR ESPd BF DSI
FR062.1R	VALORYELE	Ouarville	FR	5.2. (a)	16 t/h	M	SNCR BF WS3s sWS DSI Qch
FR062.2R	VALORYELE	Ouarville	FR	5.2. (a)	16 t/h	M	SNCR BF WS3s sWS DSI Qch
FR064R	RUNGIS	Rungis	FR	5.2. (a)	17 t/h	M	SCR ESPd BF DSI
FR070	ALCEA - Nantes	Nantes	FR	5.2. (a)	19 t/h	M	SCR BF DS_rea
FR071.1R	Carrières Sur Seine	Carrières Sur Seine	FR	5.2. (a)	20 t/h	M	SCR BF DSI

Reference line	Name of the installation	City	Country	Main activity	Capacity	Prevalent type of waste burnt	Flue-gas cleaning techniques installed
FR071.2R	Carrières Sur Seine	Carrières Sur Seine	FR	5.2. (a)	20 t/h	M	SCR BF DSI
FR072.1R	Lagny	Saint Thibault des Vignes	FR	5.2. (a)	20 t/h	M	SNCR ESPd BF DSI
FR072.2R	Lagny	Saint Thibault des Vignes	FR	5.2. (a)	20 t/h	M	SNCR ESPd BF DSI
FR073.1R	ESIANE	Villers St Paul	FR	5.2. (a)	20 t/h	M	SNCR ESPd BF DSI
FR073.2R	ESIANE	Villers St Paul	FR	5.2. (a)	20 t/h	M	SNCR ESPd BF DSI
FR075R	Cergy	Saint Ouen l'Aumone	FR	5.2. (a)	21 t/h	M	SCR BF WS1s WS2s
FR076.1R	MULHOUSE	Sausheim	FR	5.2. (a)	21 t/h	M	SCR ESPd ESPw Cyc WS2s
FR076.2R	MULHOUSE	Sausheim	FR	5.2. (a)	21 t/h	M	SCR ESPd ESPw Cyc WS2s
FR077R	SARCELLES	Sarcelles	FR	5.2. (a)	20 t/h	M	SCR BF DSI
FR078R	Bourgoin-Jallieu	Bourgoin-Jallieu	FR	5.2. (a)	22 t/h	M	SCR BF sWS
FR080.1R	W-T-E Plant Thiverval-Grignon	Thiverval Grignon	FR	5.2. (a)	27.8 t/h	M	SNCR ESPd WS2s DSI Qch
FR080.2R	W-T-E Plant Thiverval-Grignon	Thiverval Grignon	FR	5.2. (a)	27.8 t/h	M	SNCR ESPd WS2s DSI Qch
FR080.3	W-T-E Plant Thiverval-Grignon	Thiverval Grignon	FR	5.2. (a)	243000 t/yr	M	SNCR BF WS1s WS2s DSI Qch
FR082.1R	NOVALIE	Vedene	FR	5.2. (a)	26.8 t/h	M	SNCR BF sWS DSI
FR082.2R	NOVALIE	Vedene	FR	5.2. (a)	26.8 t/h	M	SNCR BF sWS DSI
FR082.3R	NOVALIE	Vedene	FR	5.2. (a)	26.8 t/h	M	SNCR BF sWS DSI
FR082.4R	NOVALIE	Vedene	FR	5.2. (a)	26.8 t/h	M	SNCR BF sWS DSI

Reference line	Name of the installation	City	Country	Main activity	Capacity	Prevalent type of waste burnt	Flue-gas cleaning techniques installed
FR083.1R	OREADE	Saint Jean de Folleville	FR	5.2. (a)	24 t/h	M	SCR ESPd BF DSI
FR083.2R	OREADE	Saint Jean de Folleville	FR	5.2. (a)	24 t/h	M	SCR ESPd BF DSI
FR084.1R	ARGENTEUIL	Argenteuil	FR	5.2. (a)	24 t/h	M	SCR ESPd WS3s
FR084.2R	ARGENTEUIL	Argenteuil	FR	5.2. (a)	24 t/h	M	SCR ESPd WS3s
FR087.1R	CIE (CRETEIL)	Creteil	FR	5.2. (a)	30 t/h	M	SCR ESPd WS2s
FR087.2R	CIE (CRETEIL)	Creteil	FR	5.2. (a)	30 t/h	M	SCR ESPd WS2s
FR087.3R	CIE (CRETEIL)	Creteil	FR	5.2. (a)	30 t/h	M	SNCR ESPd BF WS2s PC Other
FR091R	GRAND QUEVILLY	Grand Quevilly	FR	5.2. (a)	43.5 t/h	M	Prim SCR ESPd BF sWS
FR092R	HALLUIN	Halluin	FR	5.2. (a)	43.5 t/h	M	Prim SCR BF WS2s sWS
FR096.1R	IVRY	Paris	FR	5.2. (a)	100 t/h	M	SCR ESPd WS3s Qch
FR096.2R	IVRY	Paris	FR	5.2. (a)	100 t/h	M	SCR ESPd WS3s Qch
FR098R	Saint-Thibault des Vignes	Saint-Thibault des Vignes	FR	5.2. (a)	3.75 t/h	S	SNCR ESPd BF DS_rea DSI
FR104R	incinerateur fos sur mer kem one	Fos/MER	FR	4.1. (f)	400 000 t/yr	H	WS3s Qch
FR106R	Four d'incinération John Zink	Chalampé	FR	5.2. (b)	325 t/d	H	Prim BF WS3s DSI Qch
FR107R	Four John ZINK	Chalampé	FR	5.2. (b)	744 t/d	H	ESPd
FR108	TREDI Saint-Vulbas	Saint-Vulbas (F-01155 Lagnieu)	FR	5.1. (b)	12 000 t/yr	H	ESPw WS1s WS2s WS3s Bed PC Qch
FR109	Trédi Salaise	Salaise-sur-Sanne (F-38150)	FR	5.2. (b)	74 000 t/yr	H	SNCR ESPd Cyc WS1s WS2s WS3s DSI PC

Reference line	Name of the installation	City	Country	Main activity	Capacity	Prevalent type of waste burnt	Flue-gas cleaning techniques installed
FR110	Sotrenor	Courrières	FR	5.2. (a)	140 000 t/yr	H	BF DSI
FR111.1	SEDIBEX	Sandouville	FR	5.2. (a)	33 t/d	H	ESPd WS2s
FR111.2	SEDIBEX	Sandouville	FR	5.2. (a)	33 t/d	H	ESPd WS2s
FR111.3	SEDIBEX	Sandouville	FR	5.2. (a)	33 t/d	H	ESPd WS2s
HU01	Dorogi hulladékégető	Dorog	HU	5.2. (b)	5 t/h	H	BF WS2s DSI Bed PC
HU02R	FKF nonprfit Zrt.	Budapest	HU	5.2. (a)	60 t/h	M	SNCR BF Cyc sWS
IT01.1R	WTE ACCAM BUSTO ARSIZIO	Busto Arsizio (VA)	IT	5.2. (a)	30.5 MW _{th}	M	SNCR BF WS1s WS2s
IT01.2R	WTE ACCAM BUSTO ARSIZIO	Busto Arsizio (VA)	IT	5.2. (a)	30.5 MW _{th}	M	SNCR BF WS1s WS2s
IT02R	ACSM-AGAM.S.p.A.	Como	IT	5.2. (a)	39 MW _{th}	M	Prim SCR ESPd BF FSI DS_rea DSI
IT03	Brianza Energia Ambiente SpA	Desio	IT	5.2. (a)	73 370 t/y	M	SNCR ESPd BF Cyc DS_ryc DS_rea PC
IT05.1R	Termovalorizzatore Silla2	Milan	IT	5.2. (a)	24.17 t/h	M	SNCR SCR ESPd BF DS_rea PC
IT05.2R	Termovalorizzatore Silla2	Milan	IT	5.2. (a)	24.17 t/h	M	SNCR SCR ESPd BF DS_rea PC
IT05.3R	Termovalorizzatore Silla2	Milan	IT	5.2. (a)	24.17 t/h	M	SNCR SCR ESPd BF DS_rea PC
IT06.1R	Termoutilizzatore di Brescia	Brescia	IT	5.2. (a)	21.8–43.6 t/h	O	Prim SNCR SCR BF DSI
IT06.2R	Termoutilizzatore di Brescia	Brescia	IT	5.2. (a)	21.8–43.6 t/h	O	Prim SNCR SCR BF DSI
IT06.3R	Termoutilizzatore di Brescia	Brescia	IT	5.2. (a)	21.8–43.6 t/h	O	Prim SNCR SCR BF DSI
IT07R	Area Impianti Bergamo	Bergamo	IT	5.2. (a)	10.5 t/h	O	SCR BF FSI DS_rea

Reference line	Name of the installation	City	Country	Main activity	Capacity	Prevalent type of waste burnt	Flue-gas cleaning techniques installed
IT09.1R	Lomellina Energia	Parona (PV)	IT	5.2. (a)	43.4 t/h	O	SNCR BF FSI DS_rea
IT09.2R	Lomellina Energia	Parona (PV)	IT	5.2. (a)	43.4 t/h	O	SNCR BF FSI DSI
IT10.1R	Rea Dalmine	Dalmine	IT	5.2. (a)	9.2 t/h	O	SCR ESPd BF DS_rea Bed PC
IT10.2R	Rea Dalmine	Dalmine	IT	5.2. (a)	9.2 t/h	O	SCR ESPd BF DS_rea Bed PC
IT11.1R	SILEA S.p.A.	Valmadrera	IT	5.2. (a)	15.6 t/h	M	SCR BF WS1s DS_rea PC
IT11.2R	SILEA S.p.A.	Valmadrera	IT	5.2. (a)	15.6 t/h	M	SCR BF WS1s WS2s DS_rea PC
IT12.1R	Tecnoborgo	Piacenza	IT	5.2. (a)	15 t/h	M	SNCR SCR ESPd BF DSI Other
IT12.2R	Tecnoborgo	Piacenza	IT	5.2. (a)	15 t/h	M	SNCR SCR ESPd BF DSI Other
IT13.1	PAIP- Polo Ambientale Integrato Provinciale	Parma	IT	5.2. (a)	130 000 t/yr	O	SNCR SCR BF DSI
IT13.2	PAIP- Polo Ambientale Integrato Provinciale	Parma	IT	5.2. (a)	130 000 t/yr	O	SNCR SCR BF DSI
IT14R	WTE MODENA	Modena	IT	5.2. (a)	27.08 t/h	M	SNCR SCR ESPd BF DS_rea DSI
IT15R	wte rimini	Coriano (RN)	IT	5.2. (a)	20 t/h	M	SNCR SCR BF DS_rea DSI
IT16R	WTE IRE Ravenna	Ravenna	IT	5.2. (a)	6 t/h	O	SNCR BF Cyc WS2s DSI PC Qch
IT17.1R	WTE FEA	Granarolo dell' Emilia, Bologna	IT	5.2. (a)	218 500 t/yr	O	Prim SCR BF WS2s DS_rcy DSI Qch
IT17.2R	WTE FEA	Granarolo dell' Emilia, Bologna	IT	5.2. (a)	218 500 t/yr	O	Prim SCR BF WS2s DS_rcy DSI Qch

Reference line	Name of the installation	City	Country	Main activity	Capacity	Prevalent type of waste burnt	Flue-gas cleaning techniques installed
IT18R	WTE Padova S. Lazzaro	Padova	IT	5.2. (a)	600 t/d	M	Prim SNCR SCR BF DSI
IT19	Waste to Energy San Zeno	Arezzo	IT	5.3. (b)	86 000 t/yr	M	SNCR PC BF DS_rea Bed
IT21.1R	TRM - IMPIANTO TERMOVALORIZZAZIONE DI TORINO	Turin	IT	5.2. (a)	421 000 t/yr	M	SCR ESPd BF DS_rea
IT21.2R	TRM - IMPIANTO TERMOVALORIZZAZIONE DI TORINO	Turin	IT	5.2. (a)	421 000 t/yr	M	SCR ESPd BF DS_rea
IT21.3R	TRM - IMPIANTO TERMOVALORIZZAZIONE DI TORINO	Turin	IT	5.2. (a)	421 000 t/yr	M	SCR ESPd BF DS_rea
IT22R	wte isernia	Pozzilli (IS)	IT	5.2. (a)	13.4 t/h	O	SNCR BF DS_rea DSI
IT23	WTE TRIESTE	Trieste	IT	5.2. (a)	223 000 t/yr	M	SNCR BF DS_rea DSI Qch
NL01R	EEW Energy from Waste Delfzijl BV	Farmsum	NL	5.2. (a)	46.4 t/h	O	SCR BF DS_rcy DSI
NL02R	Twence Holding B.V.	Hengelo	NL	5.2. (a)	99.6 t/h	O	SCR ESPd BF WS2s DSI Qch
NL03R	Waste to Energy Plant HVC Dordrecht	Dordrecht	NL	5.2. (a)	38.3 t/h	M	SCR ESPd ESPw WS2s Qch
NL04R	ZAVIN C.V.	Dordrecht	NL	5.2. (b)	30 t/d	C	SCR BF WS2s DSI
NL05R	Sewage Sludge Incineration Plant HVC Dordrecht	Dordrecht	NL	5.2. (a)	46 t/h	S	Prim SNCR PC ESPd WS3s Bed BF
NL06R	SNB	Moerdijk	NL	5.2. (a)	56 t/h	S	Prim SNCR ESPd BF FSI WS2s DSI
NO01.1R	BIR Avfallsenergi AS	Bergen	NO	5.2. (a)	28.7 t/h	M	SNCR ESPd BF WS2s DSI
NO01.2R	BIR Avfallsenergi AS	Bergen	NO	5.2. (a)	28.7 t/h	M	SNCR BF WS3s DS_rea

Reference line	Name of the installation	City	Country	Main activity	Capacity	Prevalent type of waste burnt	Flue-gas cleaning techniques installed
NO02R	Returkraft AS	Kristiansand S	NO	5.2. (a)	408 t/d	M	SCR BF WS1s DS_rcy DS_rea DSI Qch
NO03.1R	Heimdal Varmesentral	Trondheim	NO	5.2. (a)	6 t/h	M	Prim SNCR ESPd WS1s WS2s WS3s DSI Qch
NO03.2R	Heimdal Varmesentral	Trondheim	NO	5.2. (a)	6 t/h	M	Prim SNCR ESPd WS1s WS2s WS3s DSI Qch
NO03.3R	Heimdal Varmesentral	Trondheim	NO	5.2. (a)	18 t/h	M	Prim SNCR BF WS1s WS2s WS3s DSI Qch
PL01.1R	Incineration plant of non-hazardous waste (STUOŚ)	Warsaw	PL	5.2. (a)	671 t/d	S	Prim BF SNCR SCR Cyc DSI
PL01.2R	Incineration plant of non-hazardous waste (STUOŚ)	Warsaw	PL	5.2. (a)	671 t/d	S	Prim BF SNCR SCR Cyc DSI
PL02R	Incineration plant of non-hazardous waste (STUOŚ)	Kraków	PL	5.2. (a)	73 124 t/yr	S	SNCR ESPd BF Cyc DS_rea
PL03R	WASTE INCINERATION PLANT SARPI DABROWA GORNICZA	Dabrowa Górnica	PL	5.2. (b)	6.25 t/h	H	Prim SNCR SCR ESPd BF FSI WS1s WS2s DS_rcy DSI Bed Qch
PL04	Incineration plant for waste other than hazardous and inert	Warsaw	PL	5.2. (a)	60 000 t/yr	M	Prim SNCR BF DS_rcy DSI Bed
PL05	Incineration plant for waste other than hazardous and inert	Nowiny, com. Sitkówka - Nowiny	PL	5.2. (a)	28 780 t/yr	S	SNCR BF Cyc DS_rcy
PL06	Instalacja odzysku chlorowodoru z odpadowych związków chloroorganicznych	Włocławek	PL	4.3.	35 280 t/yr	H	ESPd ESPw WS3s
PL07.1R	Instalacja Termicznego Przekształcania Osadów i Skratek (ITPOS)	Łódź	PL	6.11.	84 000 t/yr	S	SNCR BF DSI

Reference line	Name of the installation	City	Country	Main activity	Capacity	Prevalent type of waste burnt	Flue-gas cleaning techniques installed
PL07.2R	Instalacja Termicznego Przekształcania Osadów i Skratek (ITPOS)	Łódź	PL	6.11.	84 000 t/yr	S	SNCR BF DSI
PT01.1	Central de Tratamento de Resíduos Sólidos Urbanos	Loures - S. João Talha	PT	5.2. (a)	84 t/h	M	SNCR BF sWS
PT01.2	Central de Tratamento de Resíduos Sólidos Urbanos	Loures - S. João Talha	PT	5.2. (a)	84 t/h	M	SNCR BF sWS
PT01.3	Central de Tratamento de Resíduos Sólidos Urbanos	Loures - S. João Talha	PT	5.2. (a)	84 t/h	M	SNCR BF sWS
PT02.1	Lipor	Maia	PT	5.2. (a)	380 000 t/yr	M	SNCR BF sWS DSI
PT02.2	Lipor	Maia	PT	5.2. (a)	380 000 t/yr	M	SNCR BF sWS DSI
PT03.1	Estação de Tratamento de Resíduos Sólidos da Meia Serra	Santa Cruz	PT	5.2. (a)	8 t/h	M	SNCR BF sWS
PT03.2	Estação de Tratamento de Resíduos Sólidos da Meia Serra	Santa Cruz	PT	5.2. (a)	8 t/h	M	SNCR BF sWS
SE02R	Umeå Energi AB	Umeå	SE	5.2. (a)	20 t/h	M	Prim SNCR BF WS2s DSI Other
SE03R	Gärstadverket	Linköping	SE	5.2. (a)	26.4 t/h	O	SNCR BF WS2s DSI Qch Other
SE06R	Avfallskraftvärmeverket Renova	Gothenburg	SE	5.2. (a)	73 t/h	O	Prim SCR ESPd ESPw WS3s Qch
SE09R	Filbornaverket	Helsingborg	SE	5.2. (a)	25 t/h	O	SNCR BF WS1s
SE15	NA	NA	SE	1.1	45 MW	O	SNCR BF DSI
SE20R	Bristaverket	Märsta	SE	5.2. (a)	36 t/h	M	SNCR BF WS1s WS2s DSI Qch
SE21R	Ekokem Sweden	Kumla	SE	5.2. (b)	200 000 t/yr	H	SNCR BF WS2s DSI Other
UK01R	Veolia High Temperature Incineration Plant	Ellesmere Port	UK	5.2. (b)	277 t/d	H	SNCR BF WS2s Qch

Reference line	Name of the installation	City	Country	Main activity	Capacity	Prevalent type of waste burnt	Flue-gas cleaning techniques installed
UK02R	Tradebe Fawley Limited	Southampton	UK	5.2. (a)	124 t/d	H	ESPw WS1s Bed Qch
UK03R	Kirklees Energy from Waste plant	Huddersfield	UK	5.2. (a)	17 t/h	M	SNCR BF WS1s
UK04R	Bolton Thermal Recovery Facility	Bolton	UK	5.2. (a)	13 t/h	M	SNCR BF DS_ry
UK05.1R	Stoke EfW	Stoke-on-Trent	UK	5.2. (a)	12 t/h	M	SNCR BF WS1s DSI
UK05.2R	Stoke EfW	Stoke-on-Trent	UK	5.2. (a)	12 t/h	M	SNCR BF WS1s DSI
UK06.1R	Integra South East ERF Portsmouth	Portsmouth	UK	5.3. (b)	12 t/h	M	SNCR BF sWS
UK06.2R	Integra South East ERF Portsmouth	Portsmouth	UK	5.3. (b)	12 t/h	M	SNCR BF sWS
UK07.1R	ALLINGTON INCINERATOR	Allington, Maidstone	UK	5.2. (a)	3 t/h	M	Prim SNCR ESPd BF DS_rea
UK07.2R	ALLINGTON INCINERATOR	Allington, Maidstone	UK	5.2. (a)	3 t/h	M	Prim SNCR ESPd BF DS_rea
UK07.3R	ALLINGTON INCINERATOR	Allington, Maidstone	UK	5.2. (a)	3 t/h	M	Prim SNCR ESPd BF DS_rea
UK08.1R	CSWDC Ltd	Coventry	UK	5.2. (a)	36 t/h	M	SNCR BF DS_ry
UK08.2R	CSWDC Ltd	Coventry	UK	5.2. (a)	36 t/h	M	SNCR BF DS_ry
UK08.3R	CSWDC Ltd	Coventry	UK	5.2. (a)	36 t/h	M	SNCR BF DS_ry
UK09.1R	NA	London	UK	5.2. (a)	90 t/h	M	SNCR BF sWS DSI
UK09.2R	NA	London	UK	5.2. (a)	90 t/h	M	SNCR BF sWS DSI
UK09.3R	NA	London	UK	5.2. (a)	90 t/h	M	SNCR BF sWS DSI
UK10.1R	MES Environmental Ltd Wolverhampton	Wolverhampton	UK	5.2. (a)	7 t/h (per stream)	M	SNCR BF WS1s DSI
UK10.2R	MES Environmental Ltd Wolverhampton	Wolverhampton	UK	5.2. (a)	7 t/h (per stream)	M	SNCR BF WS1s DSI

Reference line	Name of the installation	City	Country	Main activity	Capacity	Prevalent type of waste burnt	Flue-gas cleaning techniques installed
UK11.1R	Dudley EfW	Dudley	UK	5.2. (a)	6 t/h	M	SNCR BF WS1s DSI Other
UK11.2R	Dudley EfW	Dudley	UK	5.2. (a)	6 t/h	M	SNCR BF WS1s DSI Other
UK12R	NA	Lincoln	UK	5.2. (a)	19.2 t/h	M	SNCR BF DS_rea PC
UK13.1R	NA	Nottingham	UK	5.2. (a)	11.3 t/h	M	SNCR BF DSI
UK13.2R	NA	Nottingham	UK	5.2. (a)	11.3 t/h	M	SNCR BF DSI
UK14.1R	Knostrop Clinical Waste Incinerator	Leeds	UK	5.2. (b)	2 t/h	C	BF DS_rea DSI
UK14.2R	Knostrop Clinical Waste Incinerator	Leeds	UK	5.2. (b)	2 t/h	C	BF DS_rea DSI
UK15R	Thames Water Utilities Ltd	Barking, Essex	UK	5.2. (a)	13.5 t/h	S	Prim ESPd BF WS2s Other
UK17R	Blackburn Meadows Renewable Energy Plant	Sheffield	UK	5.2. (a)	25 t/h	O	SNCR BF DSI
UK18	Kemsley CHP Plant K2 Incinerator	Kemsley, Sittingbourne, Kent	UK	5.2. (a)	29 MW thermal input	O	SNCR BF DSI

NB:
Main activity: 1.1 Energy – Combustion // 4 Chemical industry // 4.1(f) Chemical – Production of organic chemicals – Halogenic hydrocarbons // 4.3 Chemical – Production of phosphorus-, nitrogen- or potassium-based fertilisers // 5.1 (a) Waste – Disposal or recovery of hazardous waste – Biological treatment // 5.1 (b) Waste – Disposal or recovery of hazardous waste – Physico-chemical treatment // 5.2 (a) Waste – Disposal or recovery of waste in waste (co-)incineration plants – Non-hazardous waste // 5.2 (b) Waste – Disposal or recovery of waste in waste (co-)incineration plants – Hazardous waste // 5.3 (a) Waste – Disposal of non-hazardous waste // 5.3 (b) Waste – Recovery, or a mix of recovery and disposal, of non-hazardous waste // 6.11 Other – Independently operated treatment of waste water
Prevalent waste burnt: M = municipal solid waste; S = sewage sludge; O = other non-hazardous waste; C = clinical waste; H = hazardous waste.
Capacity: capacity as reported in the questionnaire for the main activity of the plant. The capacity may be reported for the reference line or for the entire plant. Inconsistent or missing information has been supplemented with the amount of waste burnt in 2014
Techniques to reduce emissions to air: Bed = Adsorption bed // BF = Bag filter // Cyc = (Multi-)cyclone // DS_rcy = Dry scrubber recirculation system // DS_rea = Dry scrubber mixing unit reactor // DSI = Dry sorbent injection // ESPd = Dry electrostatic precipitator // ESPw = Wet electrostatic precipitator // FSI = In-furnace desulphurisation // PC = Post-combustion // Prim = Primary techniques // Qch = Quench system // SCR = Selective catalytic reduction // SNCR = Selective non-catalytic reduction // sWS = Semi-wet scrubber // WS1s = Wet scrubber (1-stage) // WS2s = Wet scrubber (2-stage) // WS3s = Wet scrubber (3-stage).
NI = No information provided.
Source: [81, TWG 2016]

8.5 List of European bottom ash treatment plants that participated in the 2016 data collection

Reference Line	Name of the installation	City	Country	Main Activity (Annex I-D 2010/75/EU)	IBA treatment capacity (t/yr)	Type of sorting	Is the IBA treatment plant within the same installation as a WI plant?
AT.B-01	NUA-Abfallwirtschaft Anlage Hohenruppersdorf	Hohenruppersdorf	AT	5.3. (b)	NI	M,F,E,Dw,SS	No
BE.B-01	Ipalle	Beloeil	BE	5.2. (a)	NI	F,E,A,B,SS	Yes
BE.B-02	Indaver Doel	Beveren	BE	5.2. (a)	NI	M,F,E,S,Dw,SS	Yes
CZ.B-01R	WtE Plant -SAKO Brno, a.s.	Brno	CZ	5.2. (a)	120 000	M,F,E,	Yes
DE.B-01	Schlackenaufbereitungsanlage Würzburg	Würzburg	DE	NA	NI	M,F,E,A,SS	No
DE.B-02	MDSU Reesen	Burg OT Reesen	DE	5.3. (a)	NI	M,F,E,A,Dw,SS	NI
DE.B-03	Slagreatment Facility Kochendorf	Bad Friedrichshall-Kochendorf	DE	5.1. (f)	300 000	M,F,E,SS	No
DE.B-04	STORK Umweltdienste GmbH	Magdeburg	DE	5.3. (b)	600 000	M,F,E,I,N,O,A,SS	No
DE.B-05	RAA Sandersdorf-Brehna	Sandersdorf-Brehna	DE	5.3. (b)	NI	M,F,E,A,SS	No
DE.B-06	Schlackenaufbereitungsanlage Krefeld	Krefeld	DE	NA	NI	M,F,E,A,SS	No
DE.B-07	MAV Lünen GmbH, Buchenberg 70	Lünen	DE	5.3. (b)	NI	M,F,E,A,SS	No
DE.B-08	Heidemann Bremen	Bremen	DE	5.3. (b)	250 000	M,F,E,I,A,SS	No
DE.B-09	AVA Augsburg GmbH	Augsburg	DE	5.2. (a)	70 000	M,F,E,SS	Yes
DE.B-10	Müllverwertung Borsigstrasse GmbH	Hamburg	DE	5.3. (b)	90 000	M,F,E,	Yes
DE.B-11	Müllverwertung Rugenberger Damm GmbH & Co. KG	Hamburg	DE	5.3. (b)	90 000	M,F,E,A	Yes
DE.B-12	AEZ Asdonkshof	Kamp-Lintfort	DE	5.3. (b)	79 000	F,E,A,SS	Yes

Reference Line	Name of the installation	City	Country	Main Activity (Annex I-D 2010/75/EU)	IBA treatment capacity (t/yr)	Type of sorting	Is the IBA treatment plant within the same installation as a WI plant?
DE.B-13	WVW Wertstoffverwertung Wuppertal GmbH	Wuppertal	DE	5.2. (a)	140 000	M,F,E,I,A,B,SS	Yes
DE.B-14	ZV MVA Ingolstadt	Ingolstadt	DE	5.2. (a)	NI	M,F,E,B,SS	Yes
DK.B-01	Bottom ash treatment plant	Copenhagen	DK	5.3. (b)	125 000	M,F,E,I,A,SS	No
DK.B-02	Meldgaard Recycling A/S	NA	DK	5.3. (b)	750 000	M,F,E,I,A,SS	No
DK.B-03	Jørgen Rasmussen Gruppen A/S Restproduktplads	Aalborg	DK	5.3. (b)	NI	M,F,E,A,SS	No
ES.B-01R	TIRME	Palma de Mallorca	ES	5.2. (a)	200 000	M,F,E,A,SS	Yes
FR.B-01	SMECO	PONTMAIN	FR	5.3. (b)	5 500	F,E,SS	Yes
FR.B-02	SET Mont Blanc (Passy)	Passy	FR	5.3. (b)	12 000	F,E,SS	Yes
FR.B-03	SCOREL	Ouarville	FR	5.3. (b)	90 000	F,E,A,SS	Yes
FR.B-04	NA	VEDENE	FR	5.3. (b)	87 000	M,F,E,SS	Yes
FR.B-05	ARGENTEUIL	ARGENTEUIL	FR	5.2. (a)	54 250	F,E,A,SS	Yes
FR.B-06	Routière de l'Est Parisien (REP) IME Claves - Souilly	Clave Souilly	FR	5.3. (b)	200 000	M,F,E,A,SS	No
FR.B-07	BEDEMAT	BEDENAC	FR	5.3. (b)	120 000	M,F,E,A,SS	No
FR.B-08	RECYDEM	LOURCHES	FR	5.3. (b)	100 000	M,F,E,SS	No
FR.B-09	PLANGUENOUAL	PLANGUENOUAL	FR	5.3. (b)	7 000	F,SS	Yes
FR.B-10	PAU	LESCAR	FR	5.3. (b)	20 000	F,E,SS	No
IT.B-01	Officina dell'Ambiente S.p.A.	Lomello (PV)	IT	5.3. (b)	NI	M,F,E,A,SS	No
IT.B-02	RMB S.p.A.	Polpenazze del Garda (BS)	IT	5.3. (b)	NI	M,F,E,I,A,S,Dw ,Dd,SS	No

Reference Line	Name of the installation	City	Country	Main Activity (Annex I-D 2010/75/EU)	IBA treatment capacity (t/yr)	Type of sorting	Is the IBA treatment plant within the same installation as a WI plant?
NL.B-01	Twence bv SOI	Hengelo	NL	5.3. (b)	NI	F,E,A,B,SS	Yes
NL.B-02	waste to energy plant HVC Dordrecht	Alkmaar	NL	5.3. (b)	320 000	F,E,A,B,SS	No
NL.B-03	Centrale Bodemas Opwerk Installatie (CBOI)	Sluiskil	NL	5.3. (b)	700 000	M,F,E,A,B,SS	No
PT.B-01	Instalação de Tratamento e Valorização de Escórias	Vila Franca de Xira	PT	5.3. (b)	200 000	M,F,E,A,SS	No
PT.B-02	Estação de Tratamento de Resíduos Sólidos da Meia Serra	Santa Cruz	PT	NI	NI	F	Yes
SE.B-01	Gärstad waste treatment plant	Linköping	SE	5.3. (b)	87 000	F,E,SS	Yes
SE.B-02	Spillepeng Waste treatment site	Malmö	SE	5.3. (b)	129 905	F,E,A,SS	No
SE.B-03	Sävenäs waste incineration plant	Gothenburg	SE	5.3. (b)	100 000	M,F,E,I,SS	No
UK.B-01	Riverside Resource Recovery Limited	Tilbury	UK	5.3. (b)	200 000	F,E,A,B,SS	No
<p>NB: Main activity: 5.1. (f) Waste – Disposal or recovery of hazardous waste – Recycling/reclamation of inorganic materials other than metals or metal compounds // 5.2 (a) Waste – Disposal or recovery of waste in waste (co-)incineration plants – Non-hazardous waste // 5.3 (a) Waste – Disposal of non-hazardous waste // 5.3 (b) Waste – Recovery, or a mix of recovery and disposal, of non-hazardous waste. Type of sorting: A = Wind sifter / air/ -aerulic separation // B = Ballistic separation // Dd = Density separation (dry) // Dw = Density separation (wet) // E = Eddy current separation // F = Ferromagnetic separation // I = Induction all-metal separation // M = Manual sorting // N = Near-infrared separation // O = Optical separation other than NIS // S = Sink-float separation // SS = Screening / Sieving. NI = No information provided. Source: [81, TWG 2016]</p>							

8.6 Daily and yearly average emission levels achieved by the waste incineration plants reporting continuously monitored emissions in the 2016 data collection: detailed graphs

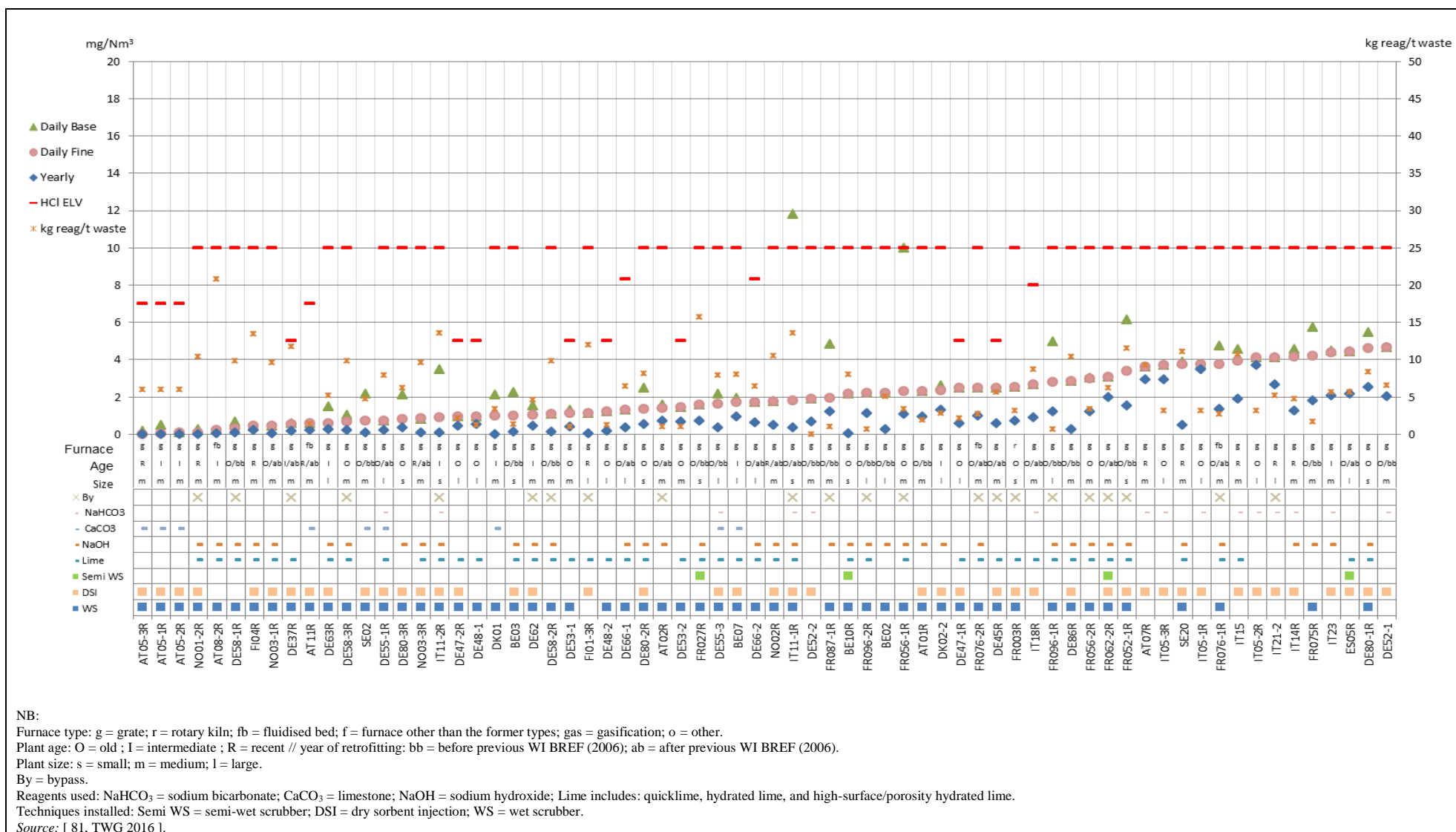

Figure 8.2: Daily and yearly average emission levels for continuously monitored HCl emissions to air from reference lines incinerating predominantly MSW (1/3)

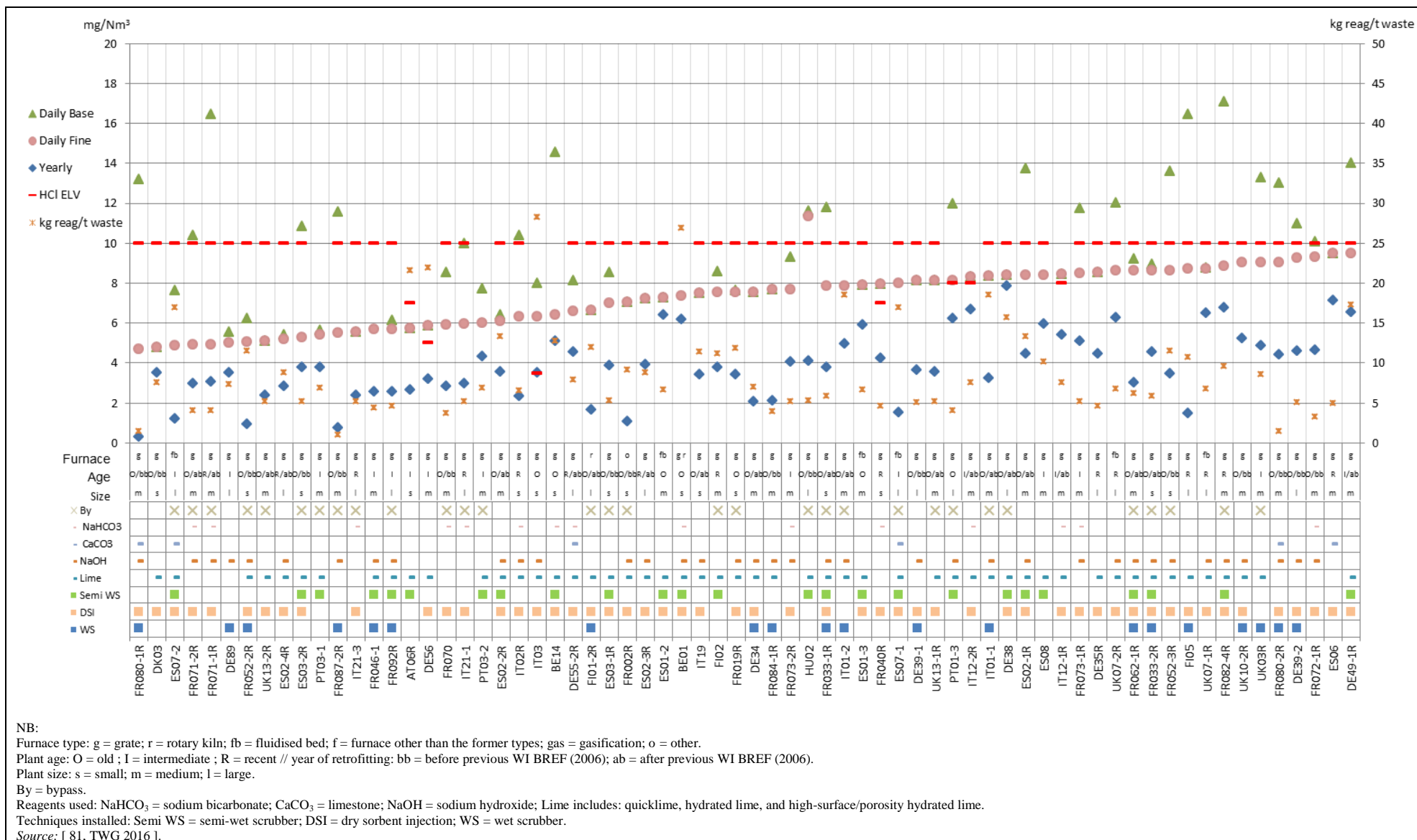

Figure 8.3: Daily and yearly average emission levels for continuously monitored HCl emissions to air from reference lines incinerating predominantly MSW (2/3)

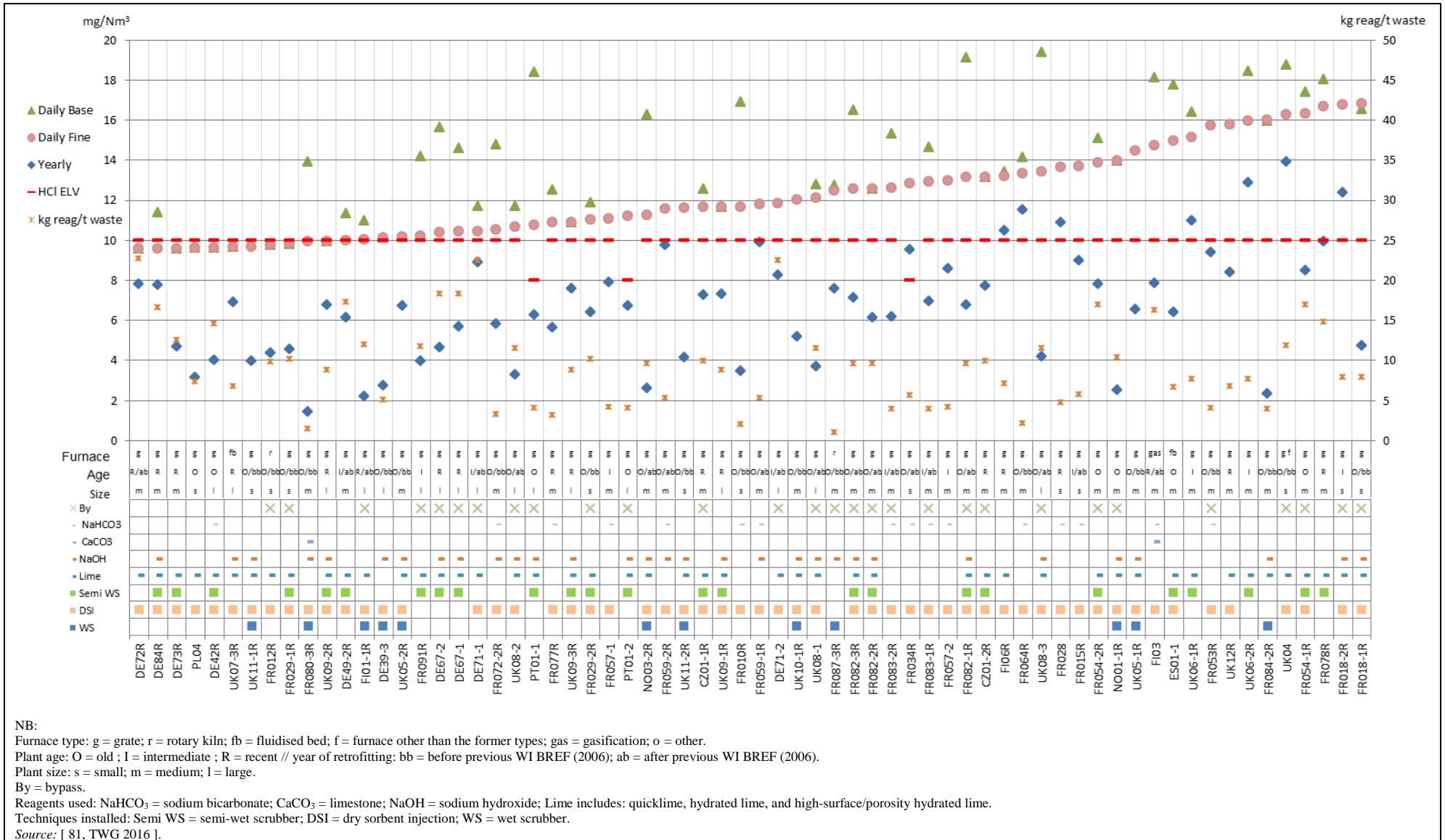

Figure 8.4: Daily and yearly average emission levels for continuously monitored HCl emissions to air from reference lines incinerating predominantly MSW (3/3)

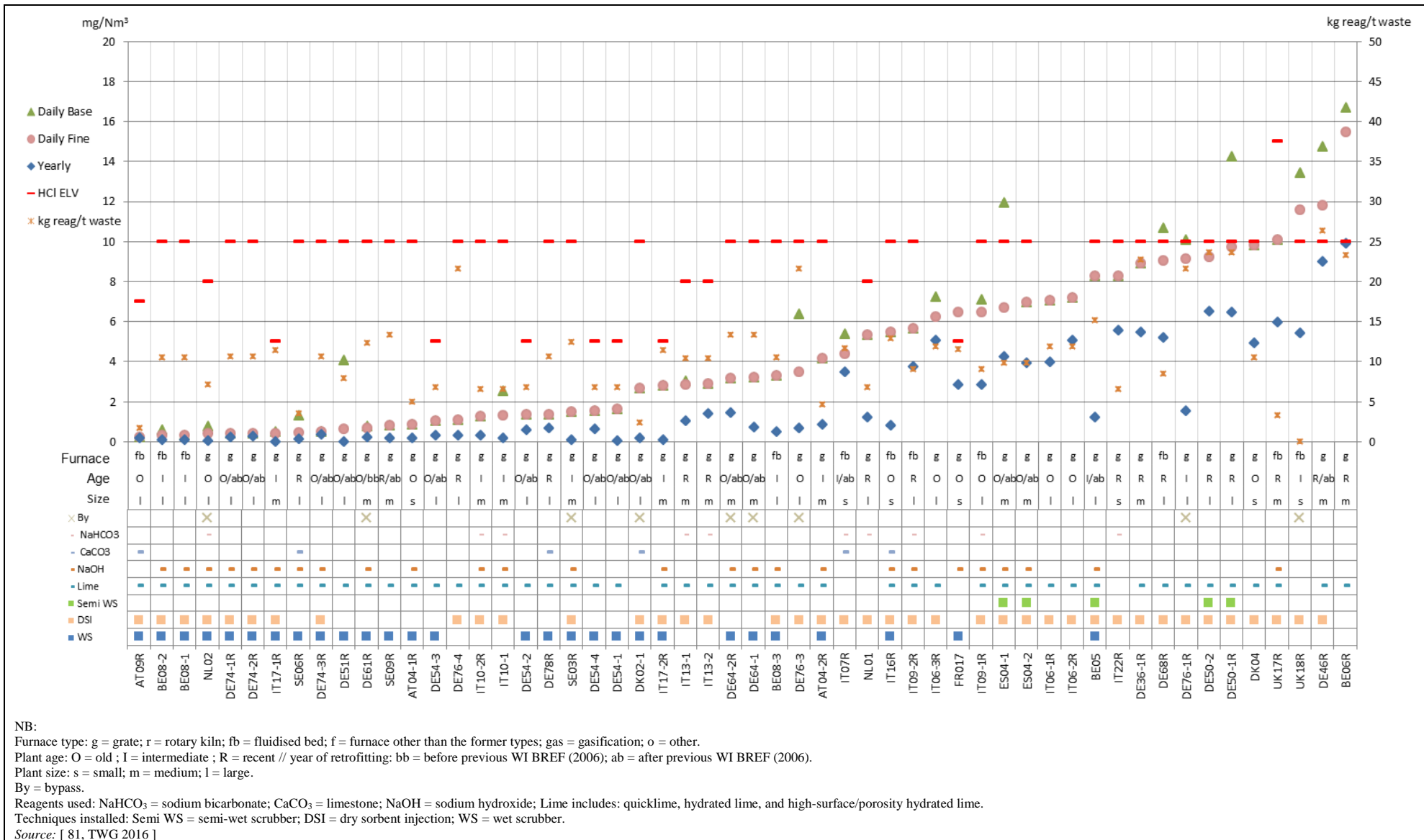

Figure 8.5: Daily and yearly average emission levels for continuously monitored HCl emissions to air from reference lines incinerating predominantly ONHW

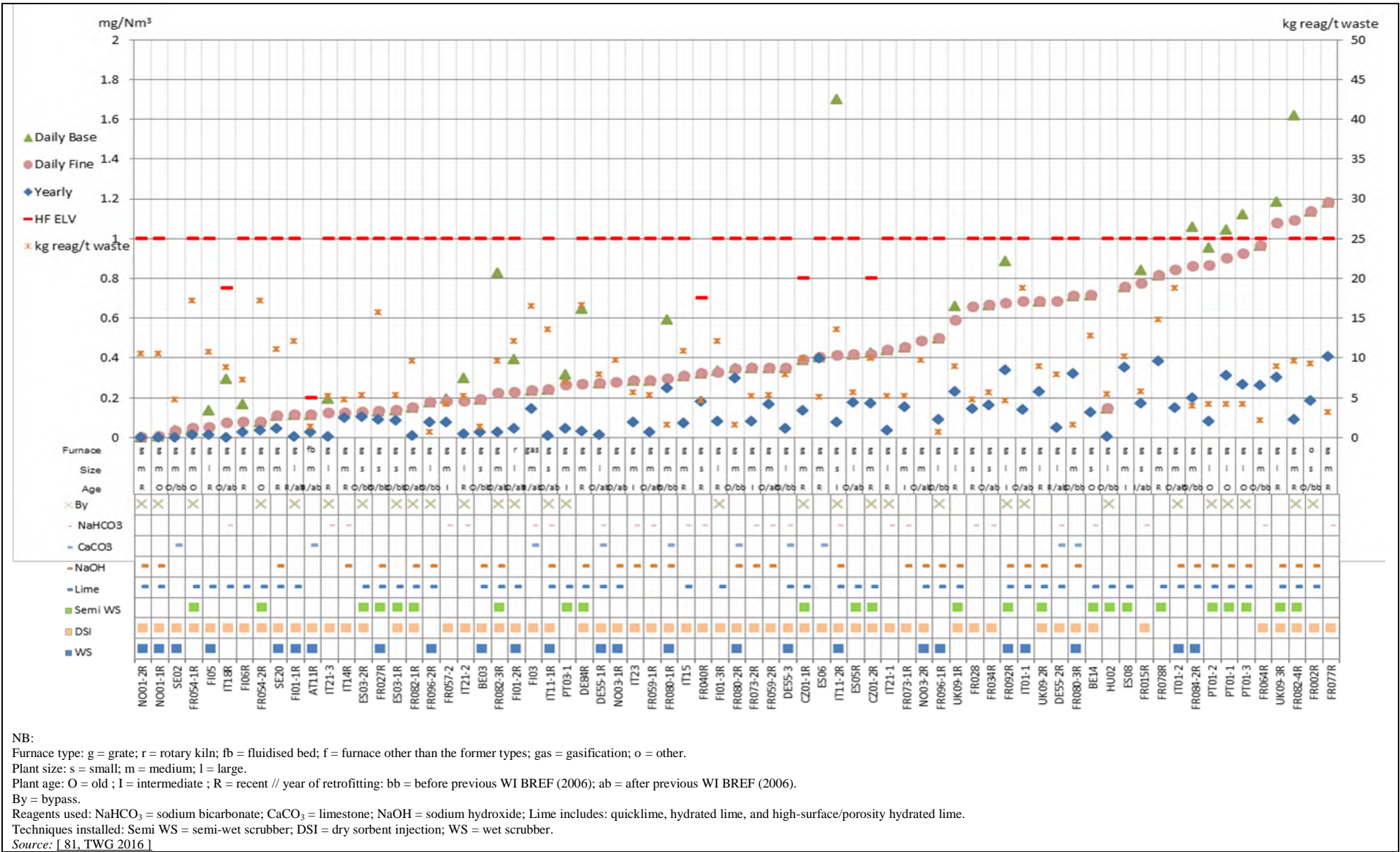
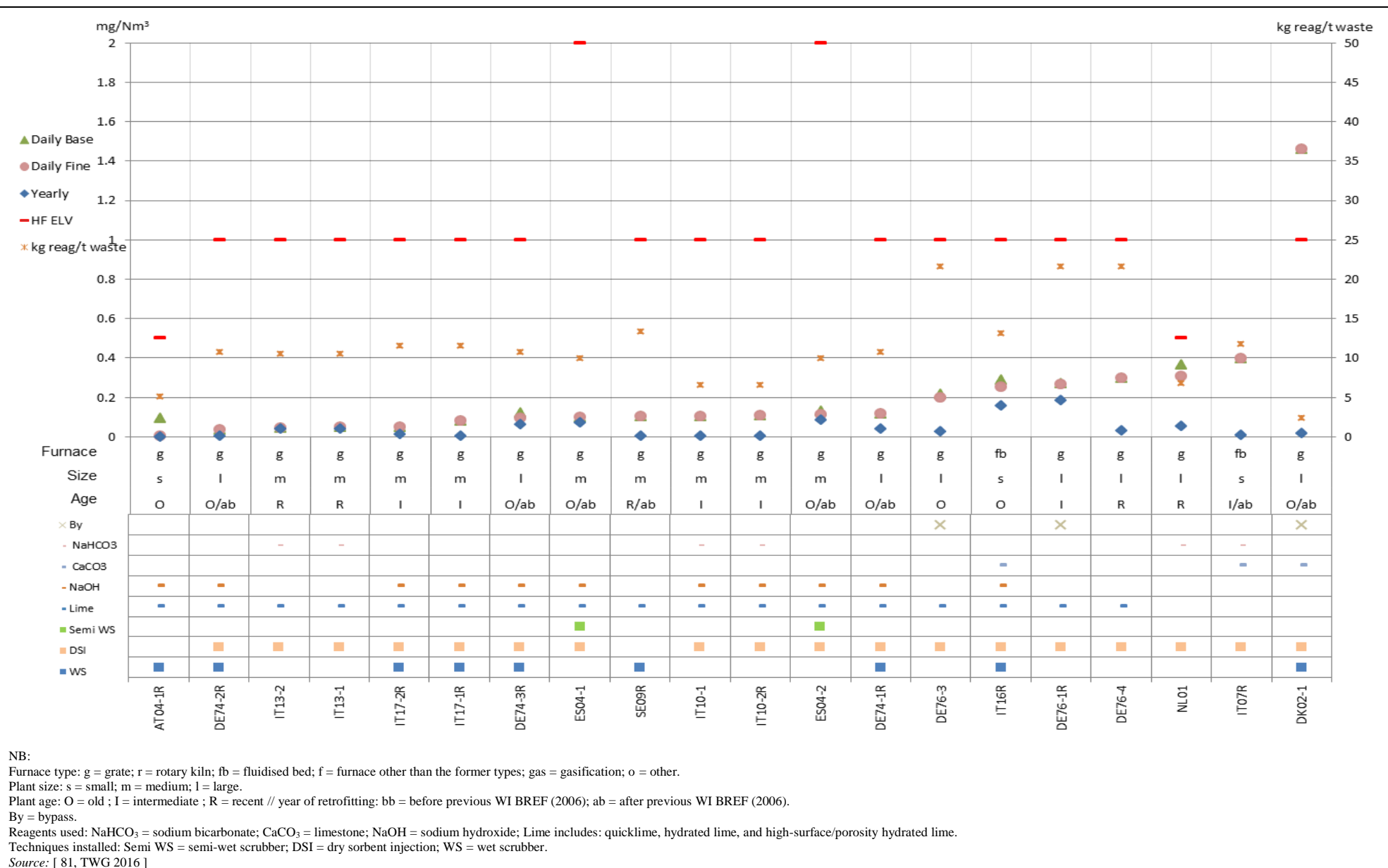

Figure 8.6: Daily and yearly average emission levels for continuously monitored HF emissions to air from reference lines incinerating predominantly MSW



NB:
 Furnace type: g = grate; r = rotary kiln; fb = fluidised bed; f = furnace other than the former types; gas = gasification; o = other.
 Plant size: s = small; m = medium; l = large.
 Plant age: O = old ; I = intermediate ; R = recent // year of retrofitting; bb = before previous WI BREF (2006); ab = after previous WI BREF (2006).
 By = bypass.
 Reagents used: NaHCO₃ = sodium bicarbonate; CaCO₃ = limestone; NaOH = sodium hydroxide; Lime includes: quicklime, hydrated lime, and high-surface/porosity hydrated lime.
 Techniques installed: Semi WS = semi-wet scrubber; DSI = dry sorbent injection; WS = wet scrubber.
 Source: [81, TWG 2016]

Figure 8.7: Daily and yearly average emission levels for continuously monitored HF emissions to air from reference lines incinerating predominantly ONHW

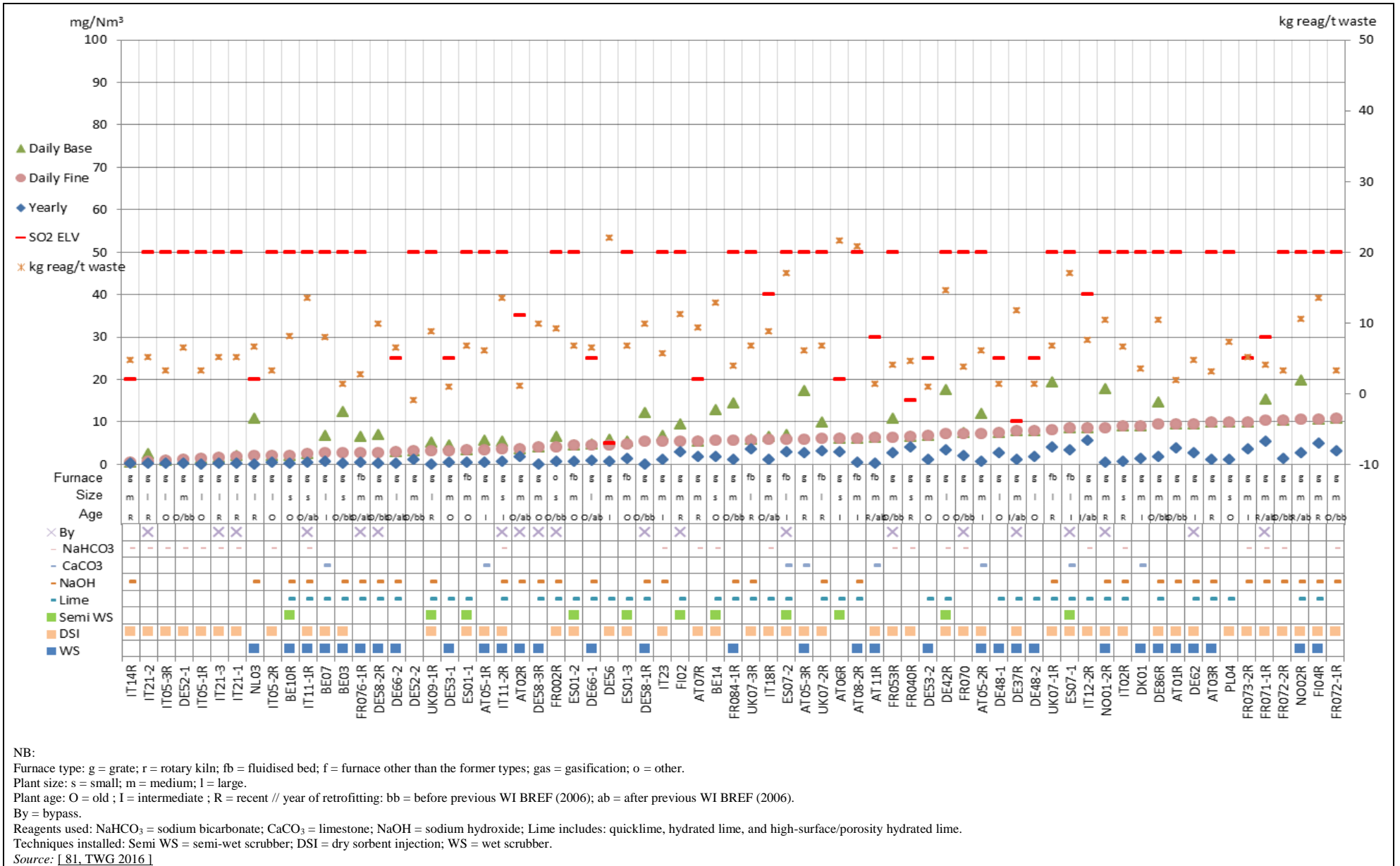

Figure 8.8: Daily and yearly average emission levels for continuously monitored SO₂ emissions to air from reference lines incinerating predominantly MSW (1/3)

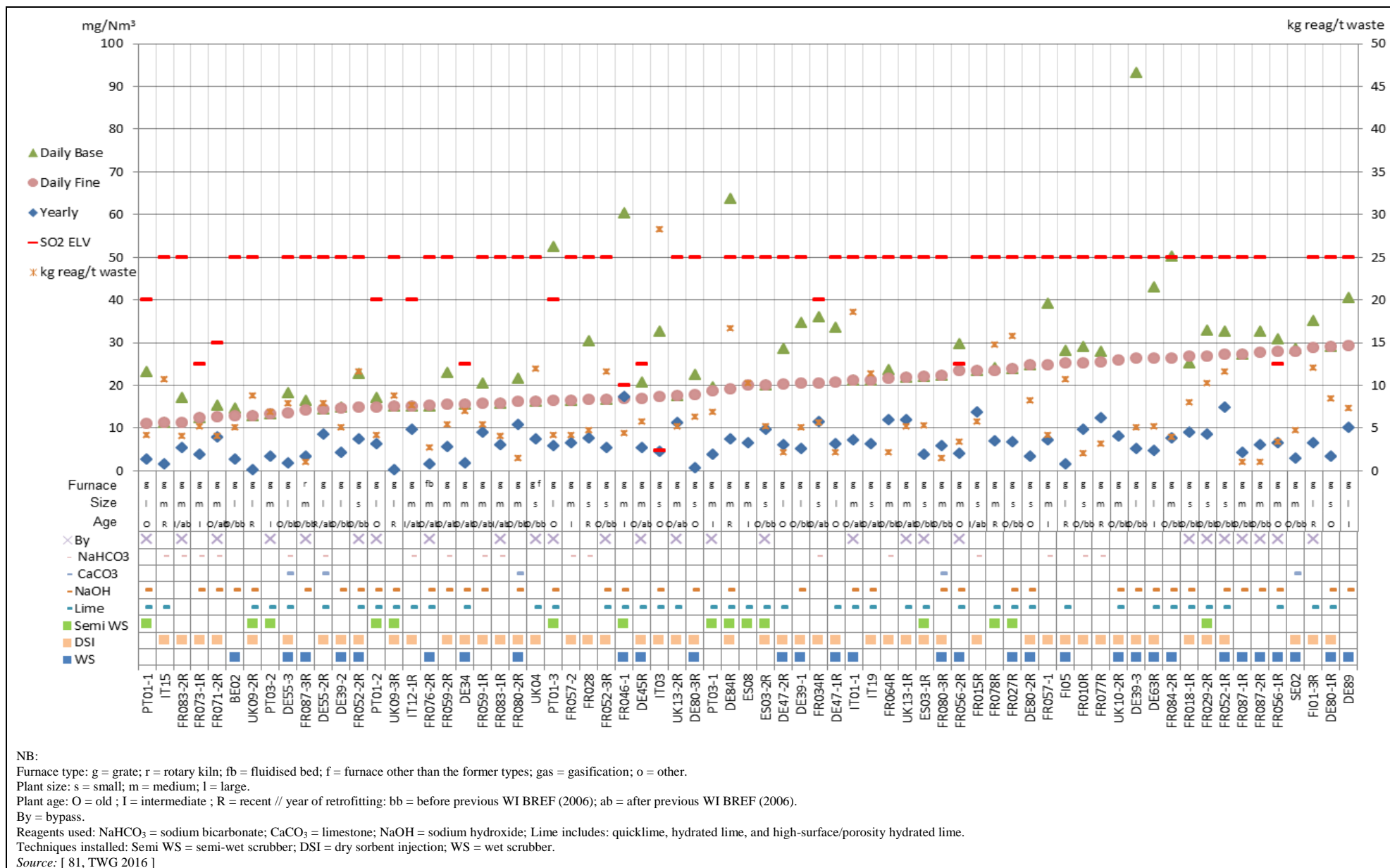

Figure 8.9: Daily and yearly average emission levels for continuously monitored SO₂ emissions to air from reference lines incinerating predominantly MSW (2/3)

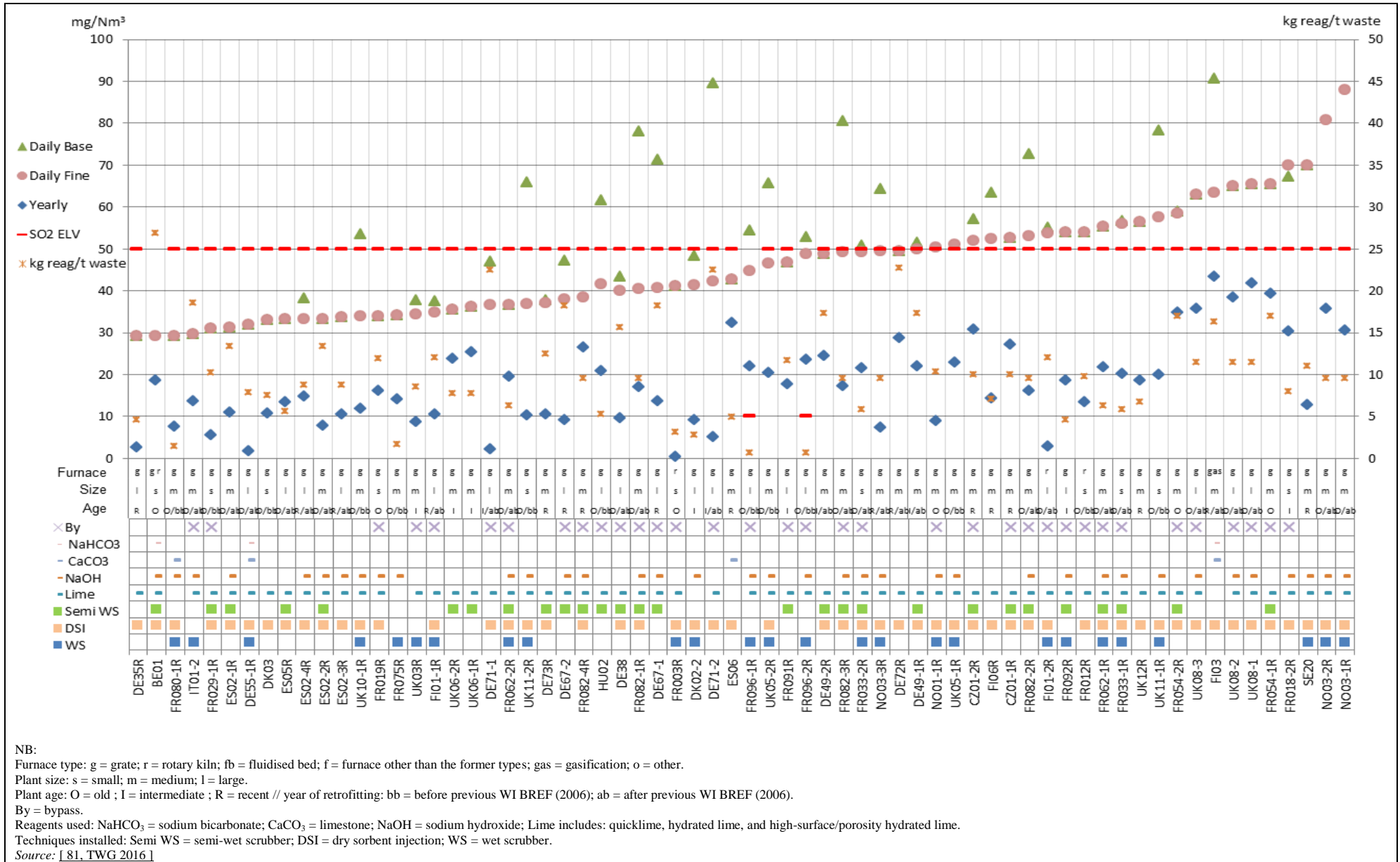

Figure 8.10: Daily and yearly average emission levels for continuously monitored SO₂ emissions to air from reference lines incinerating predominantly MSW (3/3)

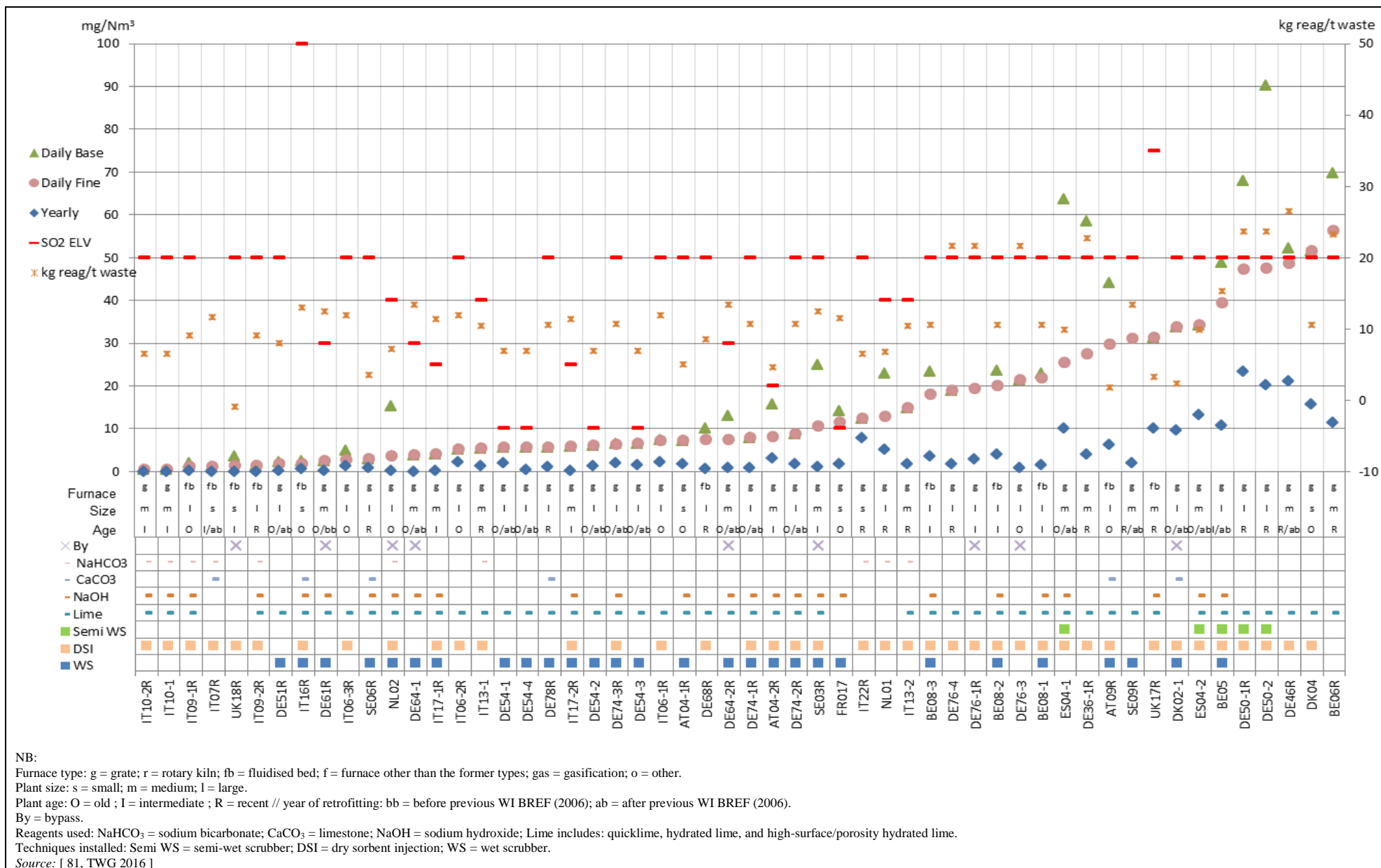
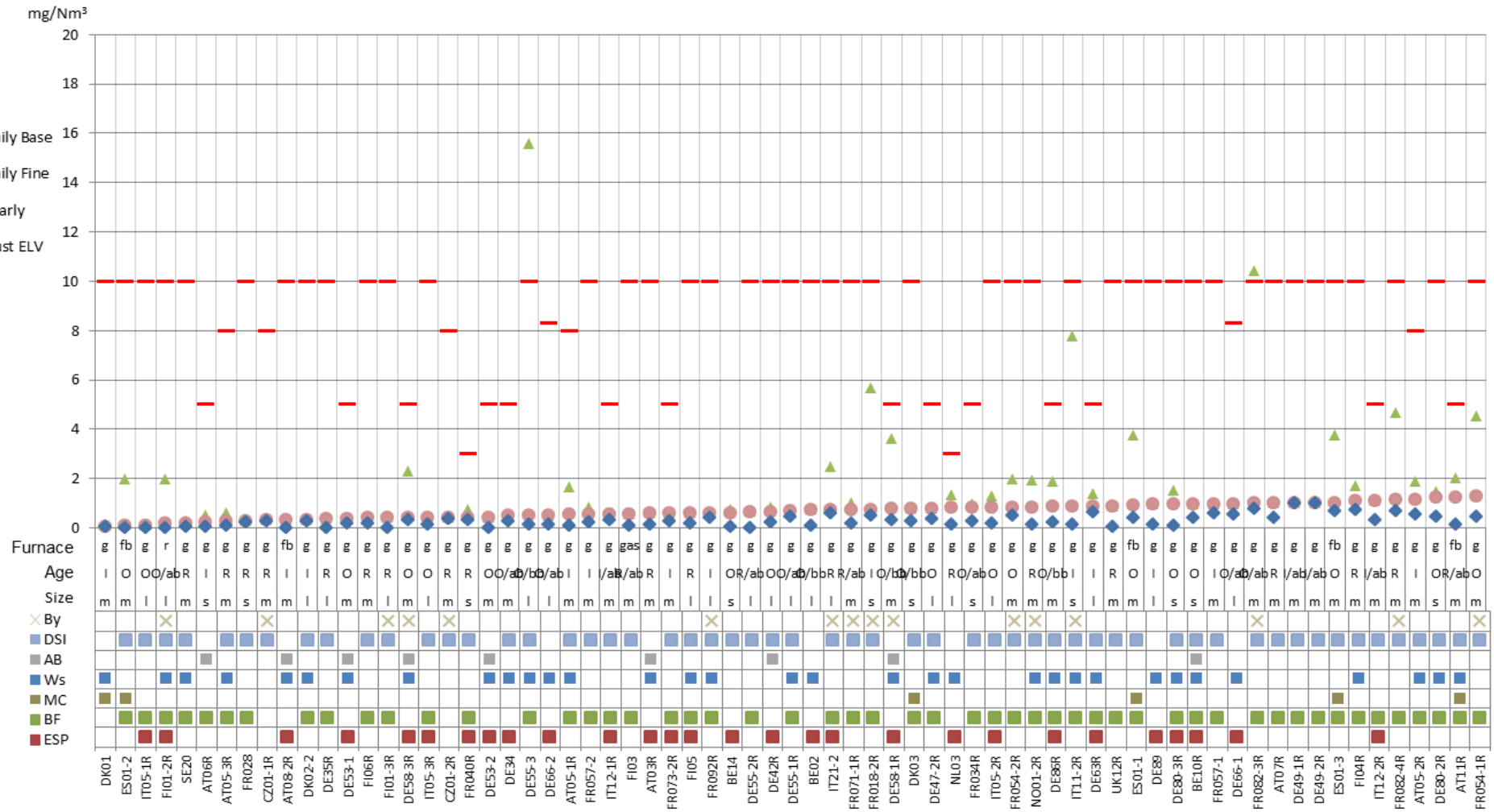
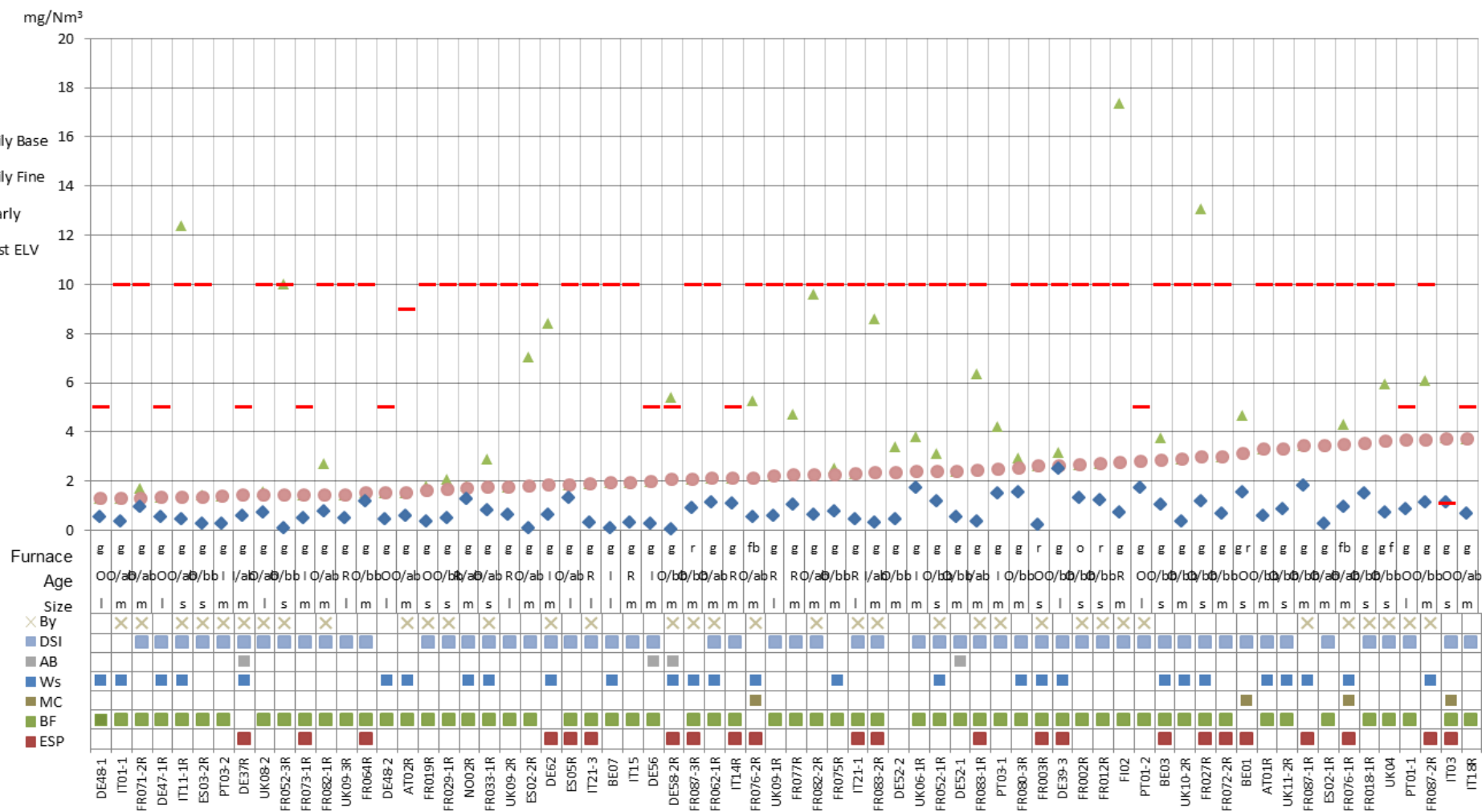

Figure 8.11: Daily and yearly average emission levels for continuously monitored SO₂ emissions to air from reference lines incinerating predominantly ONHW



NB:
 Furnace type: g = grate; r = rotary kiln; fb = fluidised bed; f = furnace other than the former types; gas = gasification; o = other.
 Plant age: O = old ; I = intermediate ; R = recent // year of retrofitting: bb = before previous WI BREF (2006); ab = after previous WI BREF (2006).
 Plant size: s = small; m = medium; l = large.
 By = bypass.
 Techniques installed: DSI = dry sorbent injection; AB = adsorption bed; WS = wet scrubber; MC = multi-cyclone; BF = bag filter; ESP = electrostatic precipitator.
 Source: [81, TWG 2016]

Figure 8.12: Daily and yearly average emission levels for continuously monitored dust emissions to air from reference lines incinerating predominantly MSW (1/3)



NB:
 Furnace type: g = grate; r = rotary kiln; fb = fluidised bed; f = furnace other than the former types; gas = gasification; o = other.
 Plant age: O = old; I = intermediate; R = recent // year of retrofitting: bb = before previous WI BREF (2006); ab = after previous WI BREF (2006).
 Plant size: s = small; m = medium; l = large.
 By = bypass.
 Techniques installed: DSI = dry sorbent injection; AB = adsorption bed; WS = wet scrubber; MC = multi-cyclone; BF = bag filter; ESP = electrostatic precipitator.
 Source: [81, TWG 2016]

Figure 8.13: Daily and yearly average emission levels for continuously monitored dust emissions to air from reference lines incinerating predominantly MSW (2/3)

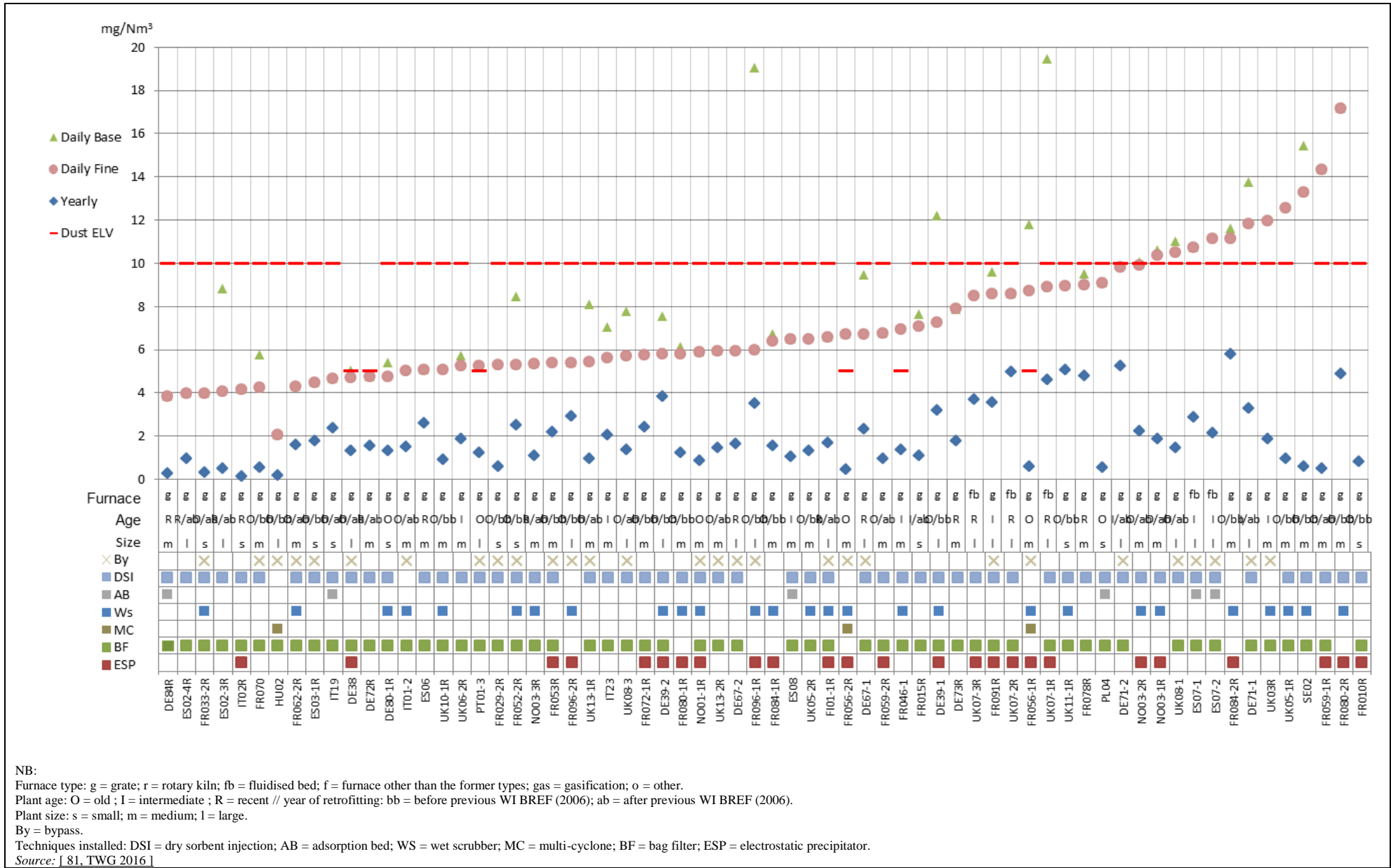

Figure 8.14: Daily and yearly average emission levels for continuously monitored dust emissions to air from reference lines incinerating predominantly MSW (3/3)

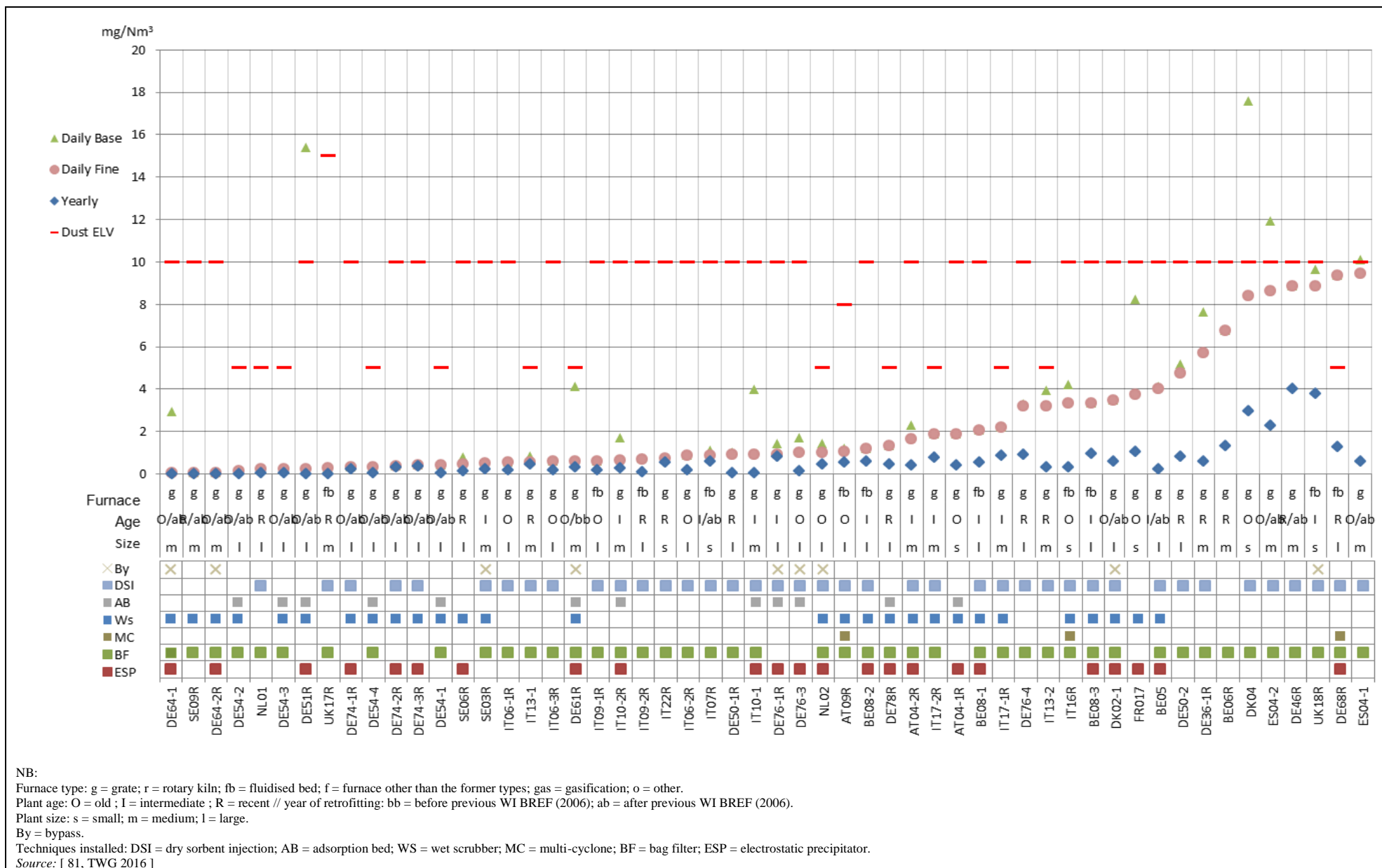

Figure 8.15: Daily and yearly average emission levels for continuously monitored dust emissions to air from reference lines incinerating predominantly ONHW

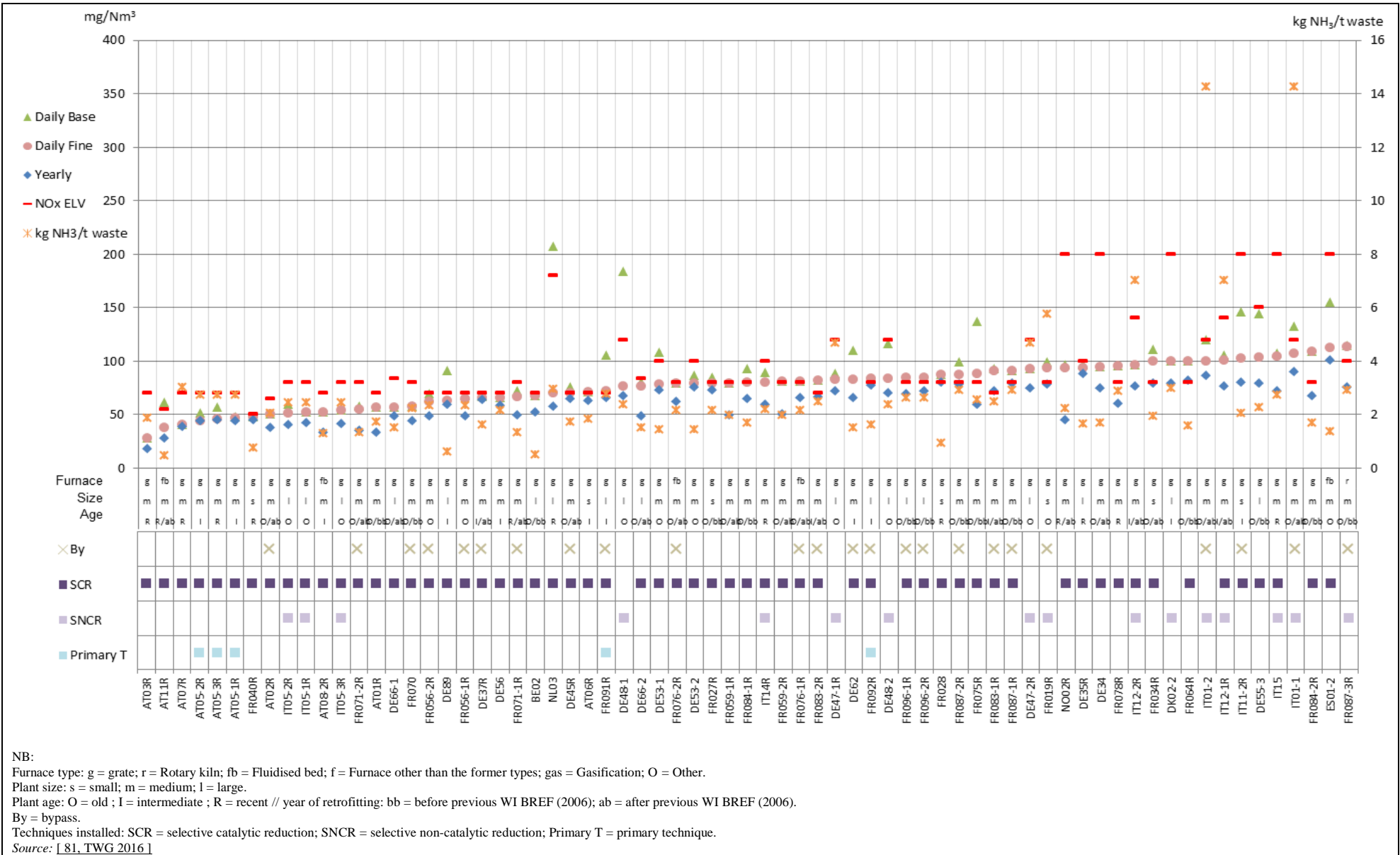

Figure 8.16: Daily and yearly average emission levels for continuously monitored NO_x emissions to air from reference lines incinerating predominantly MSW (1/3)

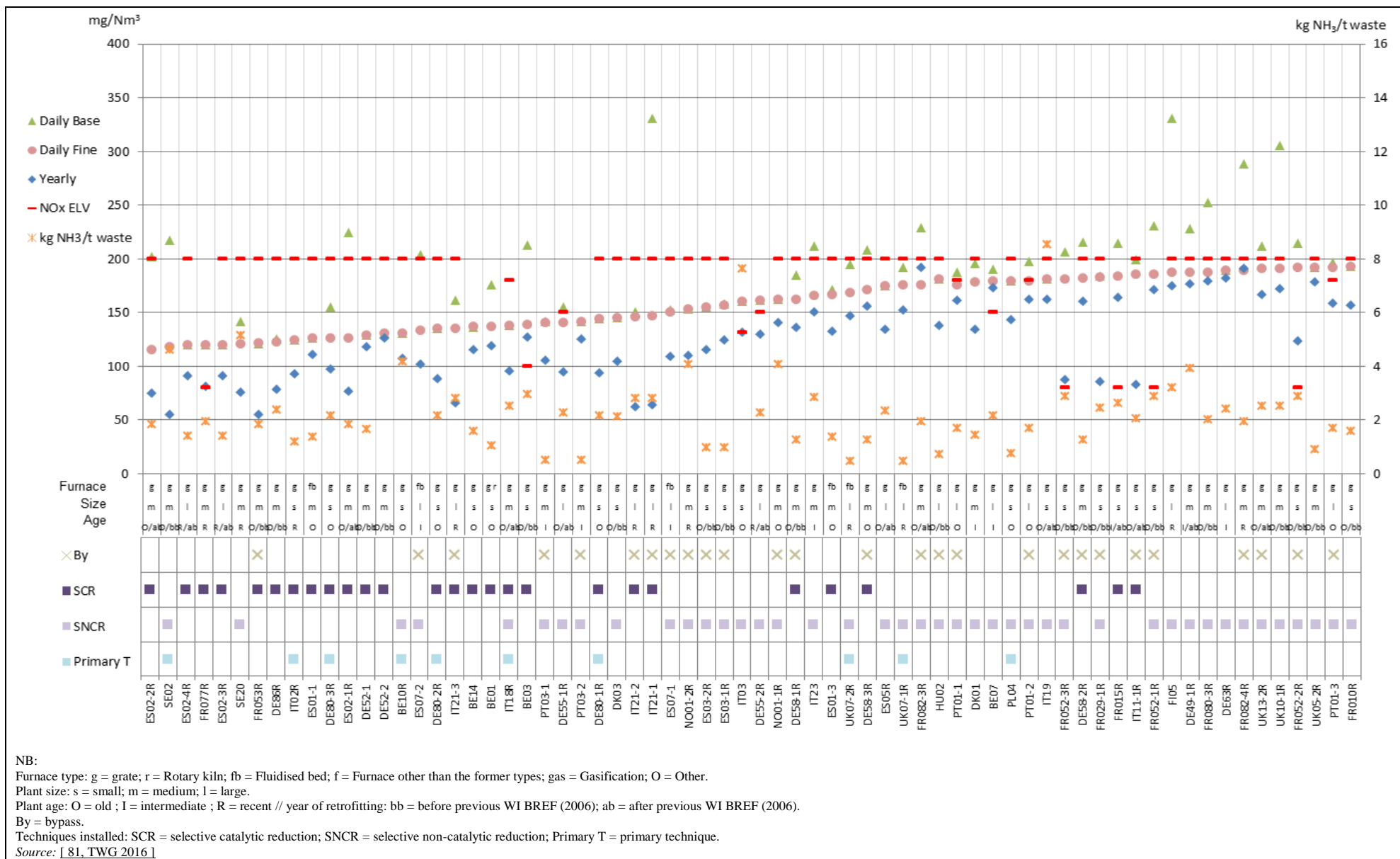

Figure 8.17: Daily and yearly average emission levels for continuously monitored NO_x emissions to air from reference lines incinerating predominantly MSW (2/3)

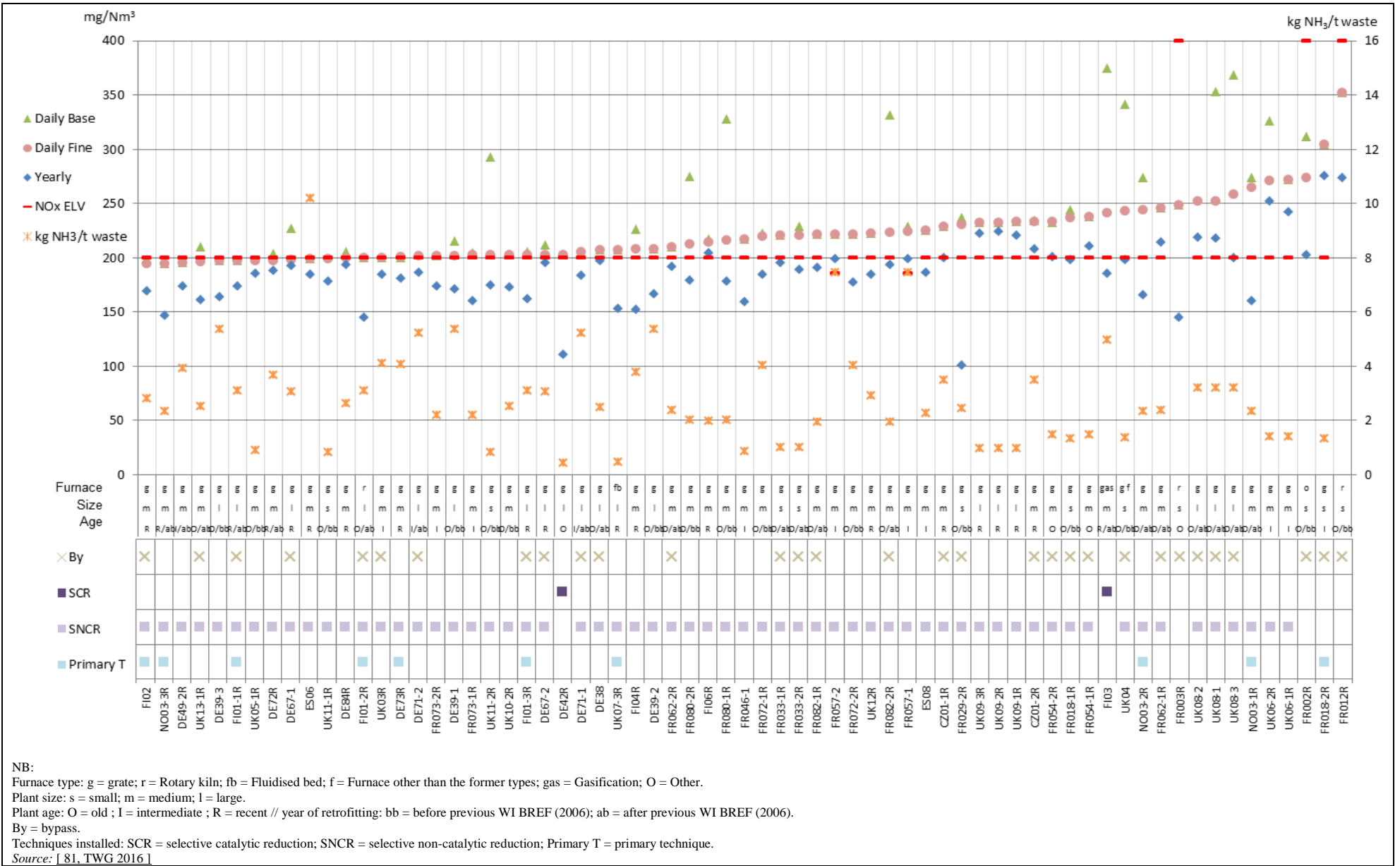

Figure 8.18: Daily and yearly average emission levels for continuously monitored NO_x emissions to air from reference lines incinerating predominantly MSW (3/3)

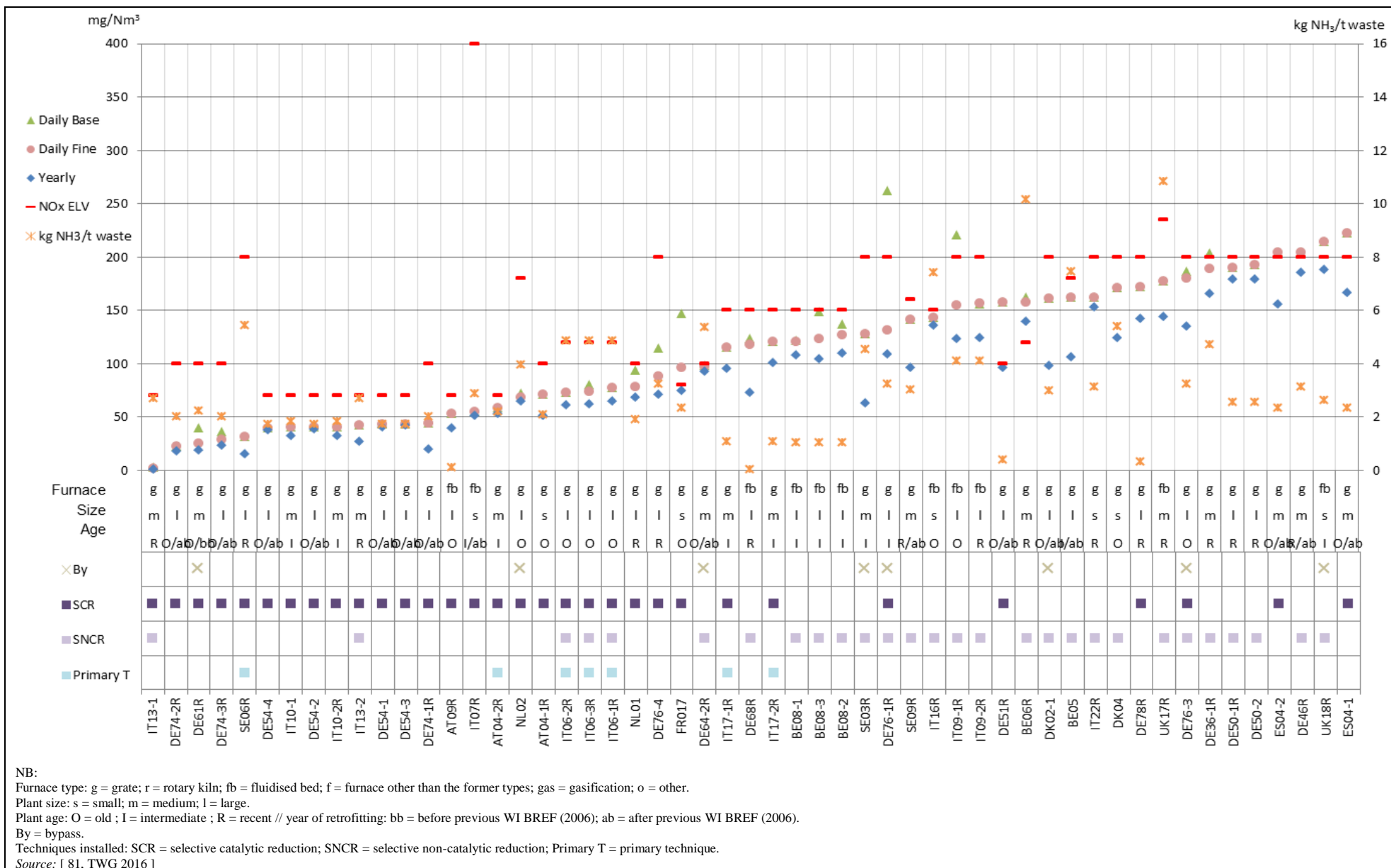

Figure 8.19: Daily and yearly average emission levels for continuously monitored NO_x emissions to air from reference lines incinerating predominantly ONHW

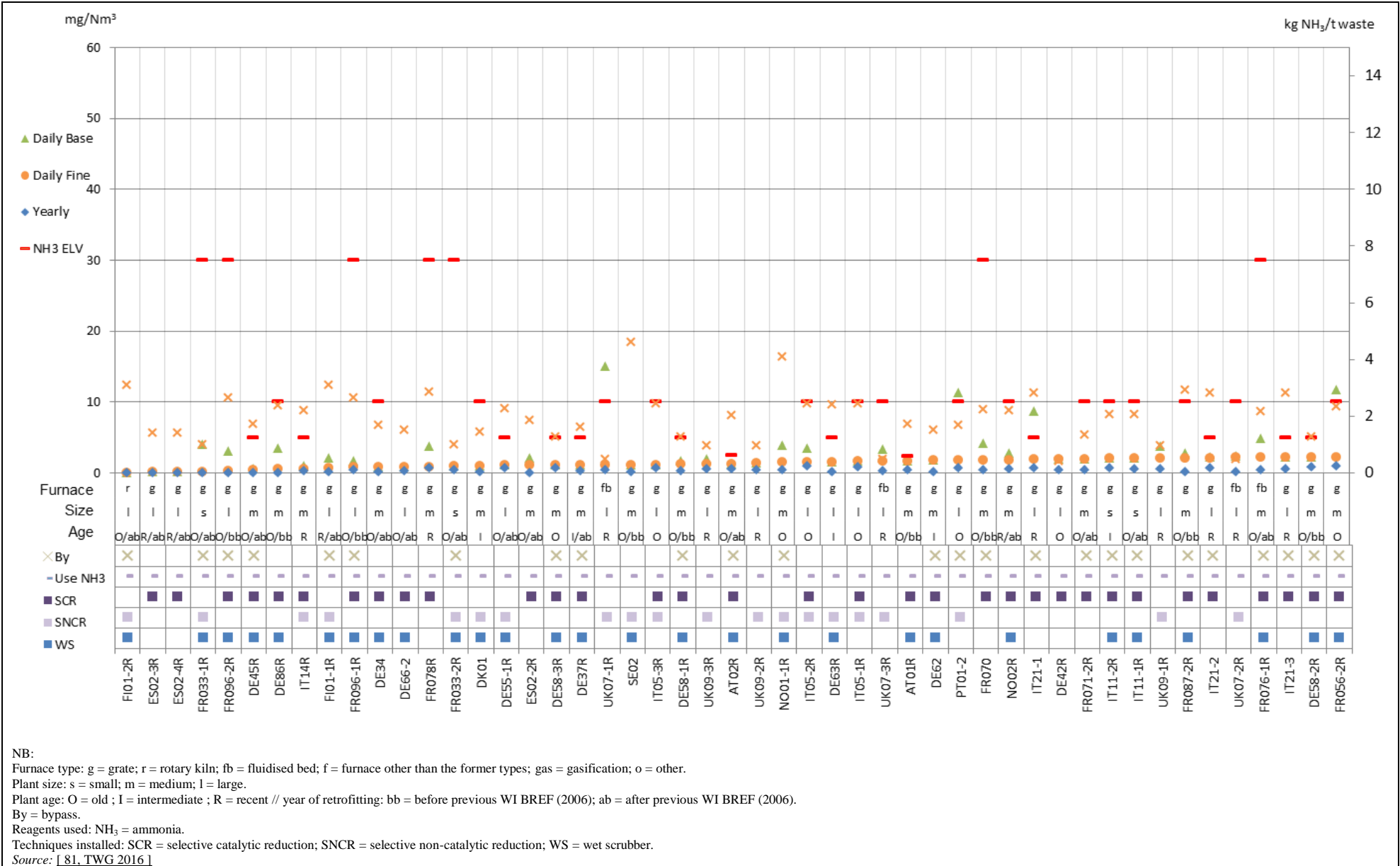

Figure 8.20: Daily and yearly average emission levels for continuously monitored NH₃ emissions to air from reference lines incinerating predominantly MSW (1/3)

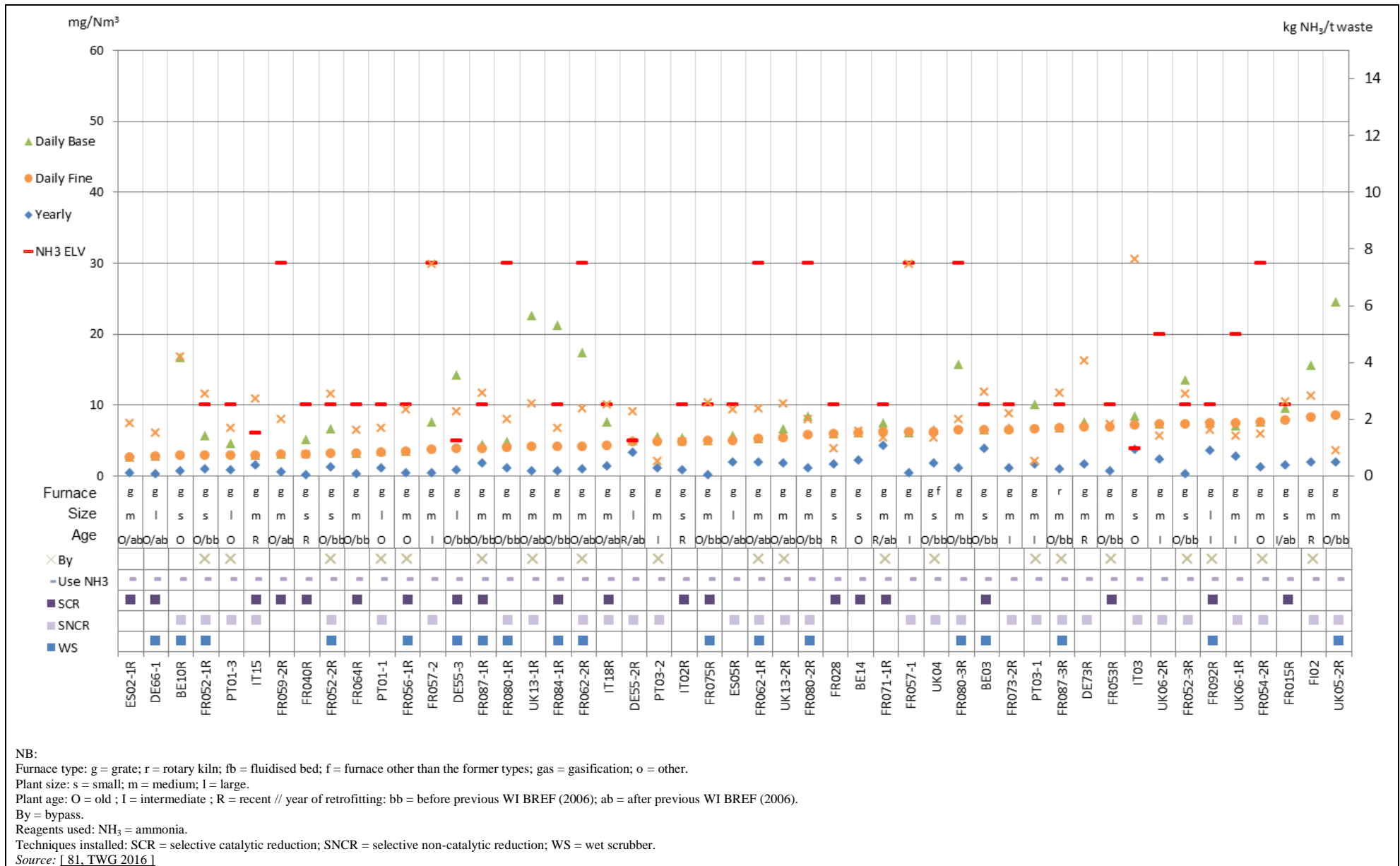

Figure 8.21: Daily and yearly average emission levels for continuously monitored NH₃ emissions to air from reference lines incinerating predominantly MSW (2/3)

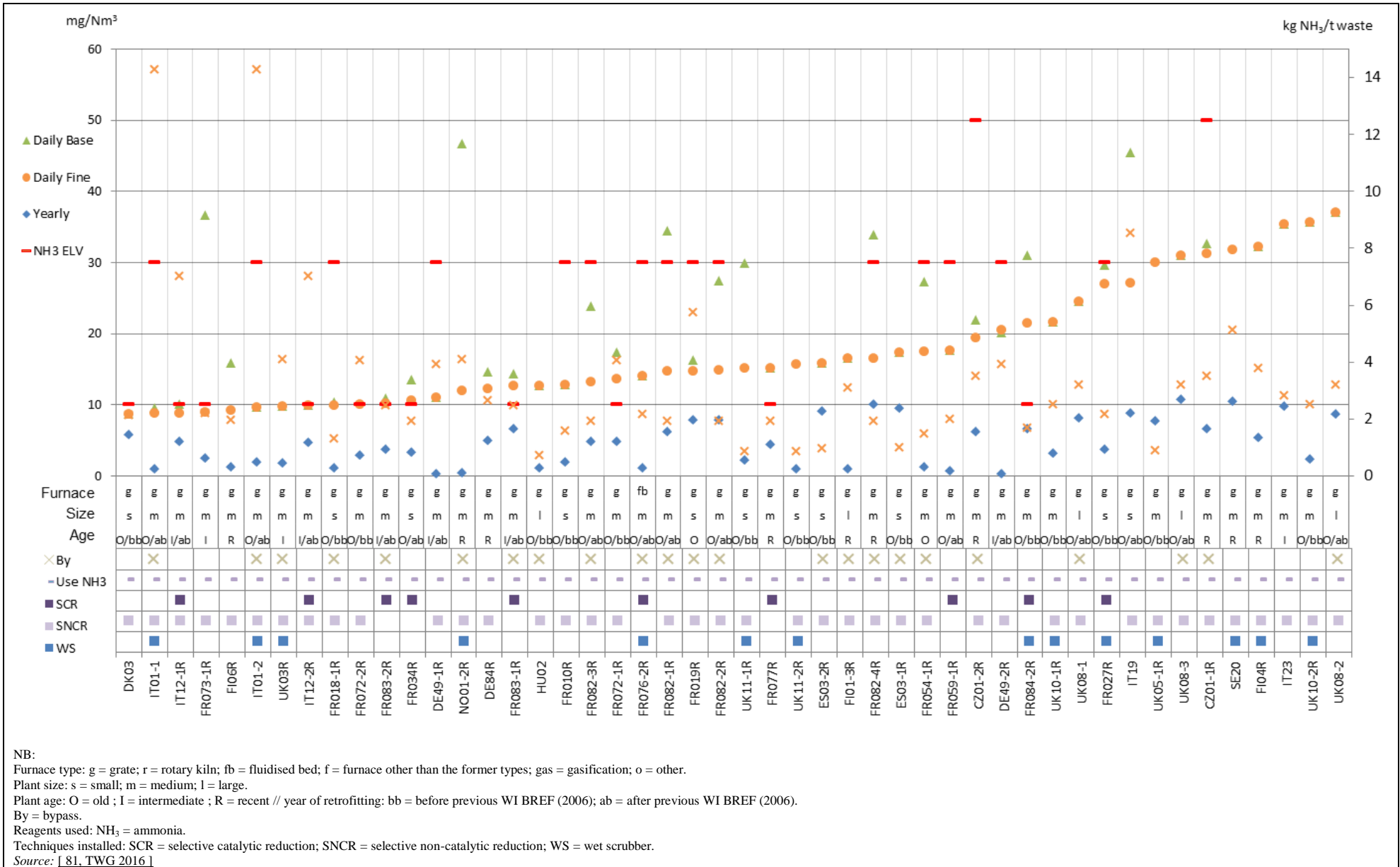

Figure 8.22: Daily and yearly average emission levels for continuously monitored NH₃ emissions to air from reference lines incinerating predominantly MSW (3/3)

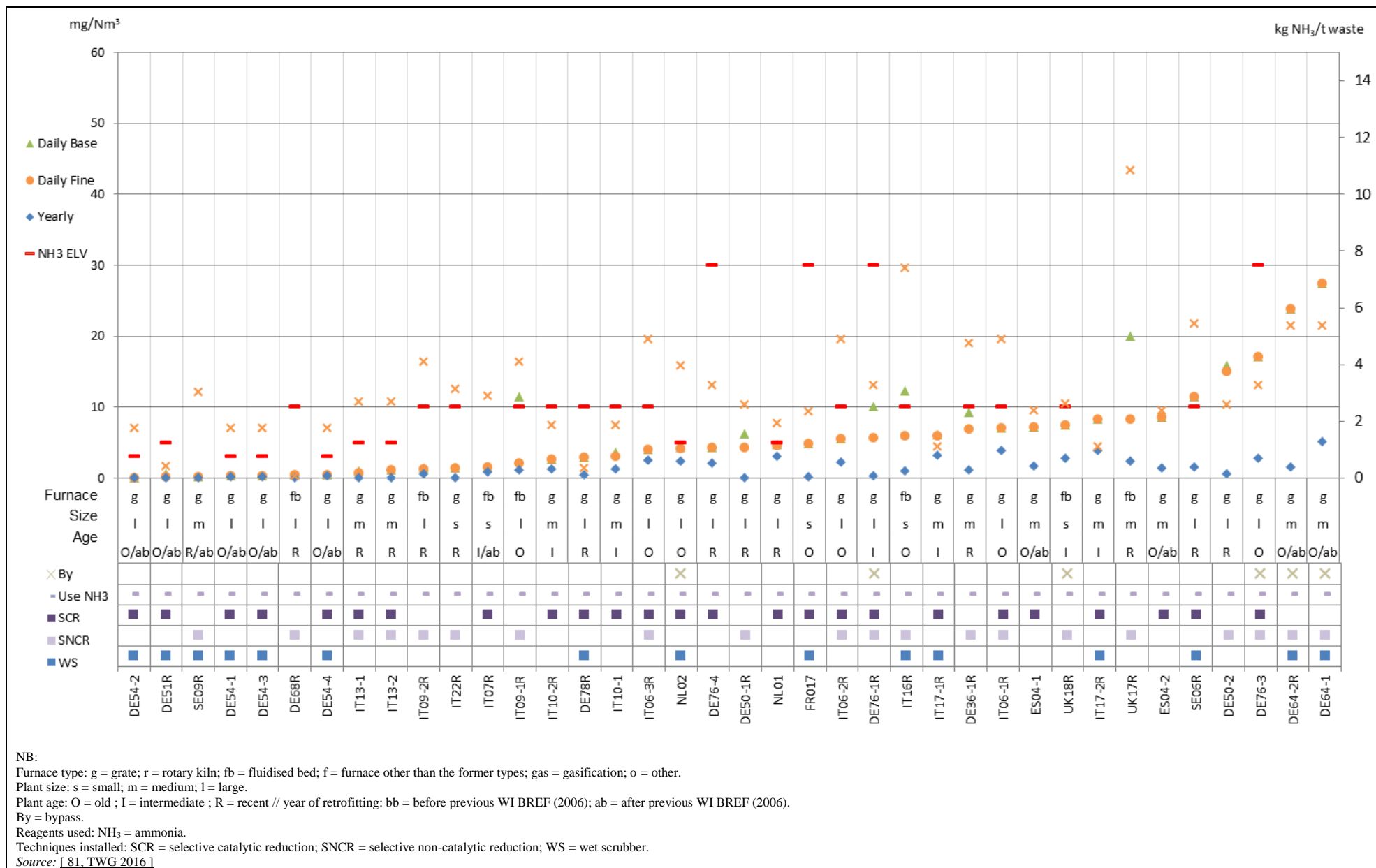

Figure 8.23: Daily and yearly average emission levels for continuously monitored NH₃ emissions to air from reference lines incinerating predominantly ONHW

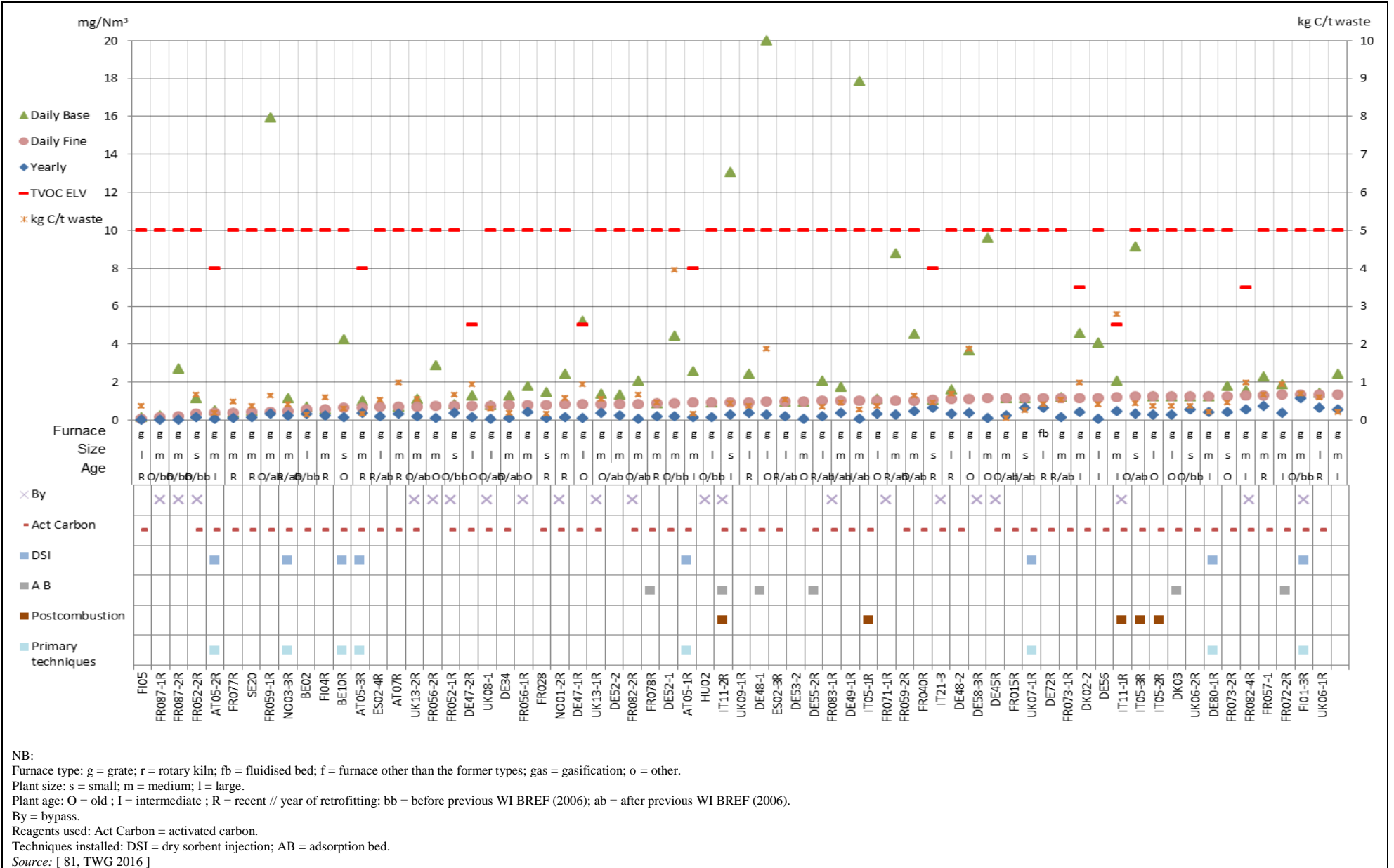

Figure 8.24: Daily and yearly average emission levels for continuously monitored TVOC emissions to air from reference lines incinerating predominantly MSW (1/3)

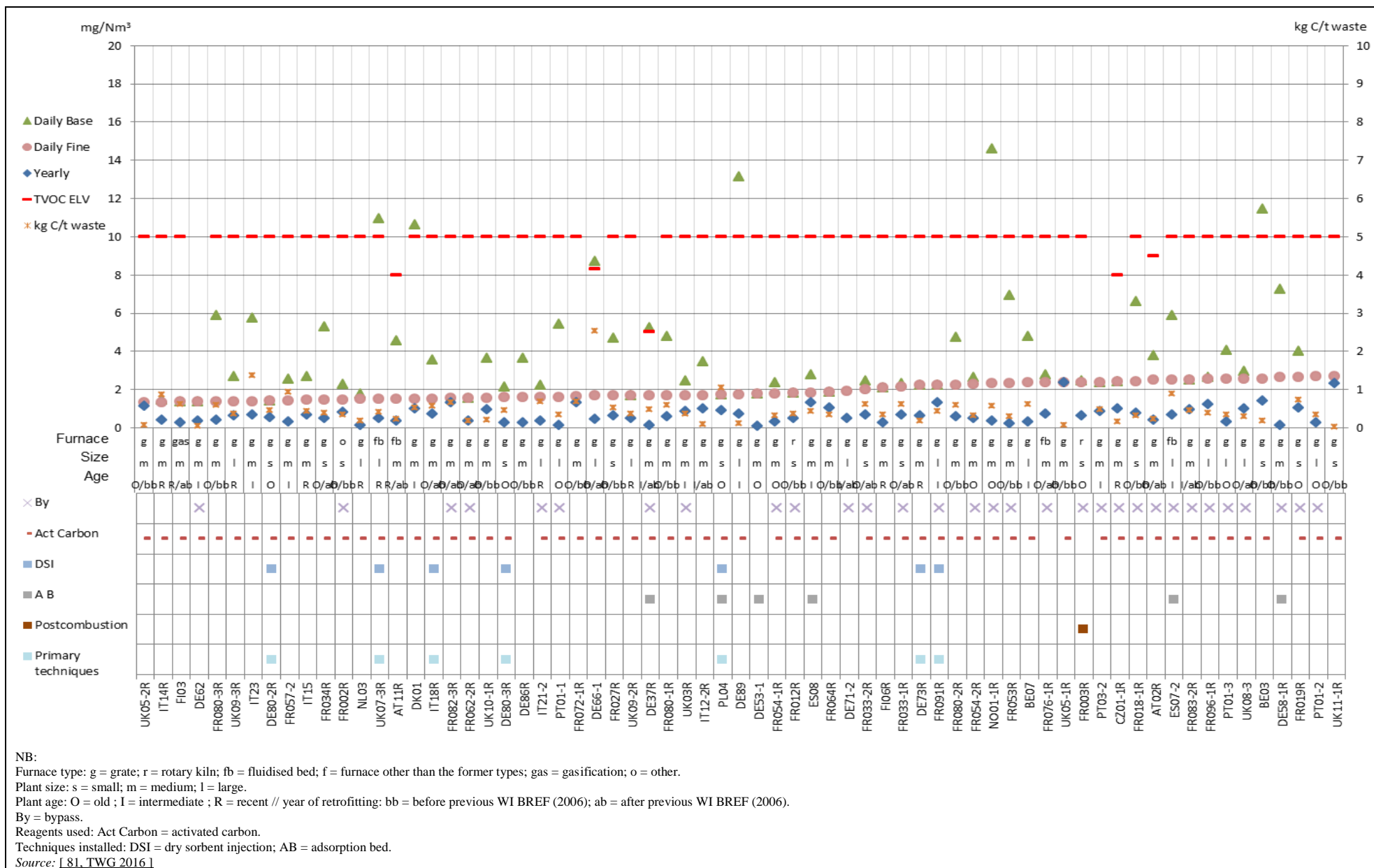

Figure 8.25: Daily and yearly average emission levels for continuously monitored TVOC emissions to air from reference lines incinerating predominantly MSW (2/3)

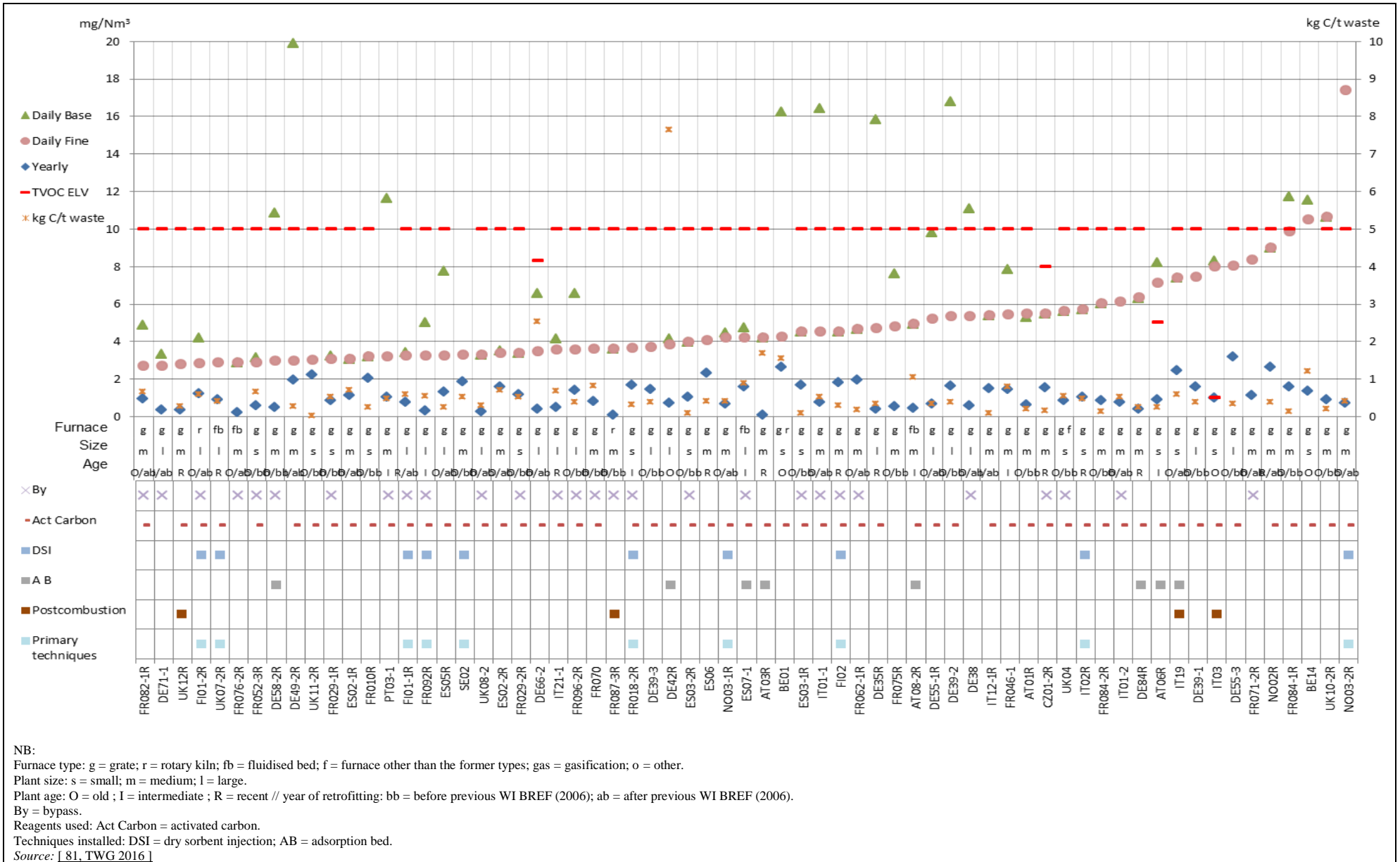

Figure 8.26: Daily and yearly average emission levels for continuously monitored TVOC emissions to air from reference lines incinerating predominantly MSW (3/3)

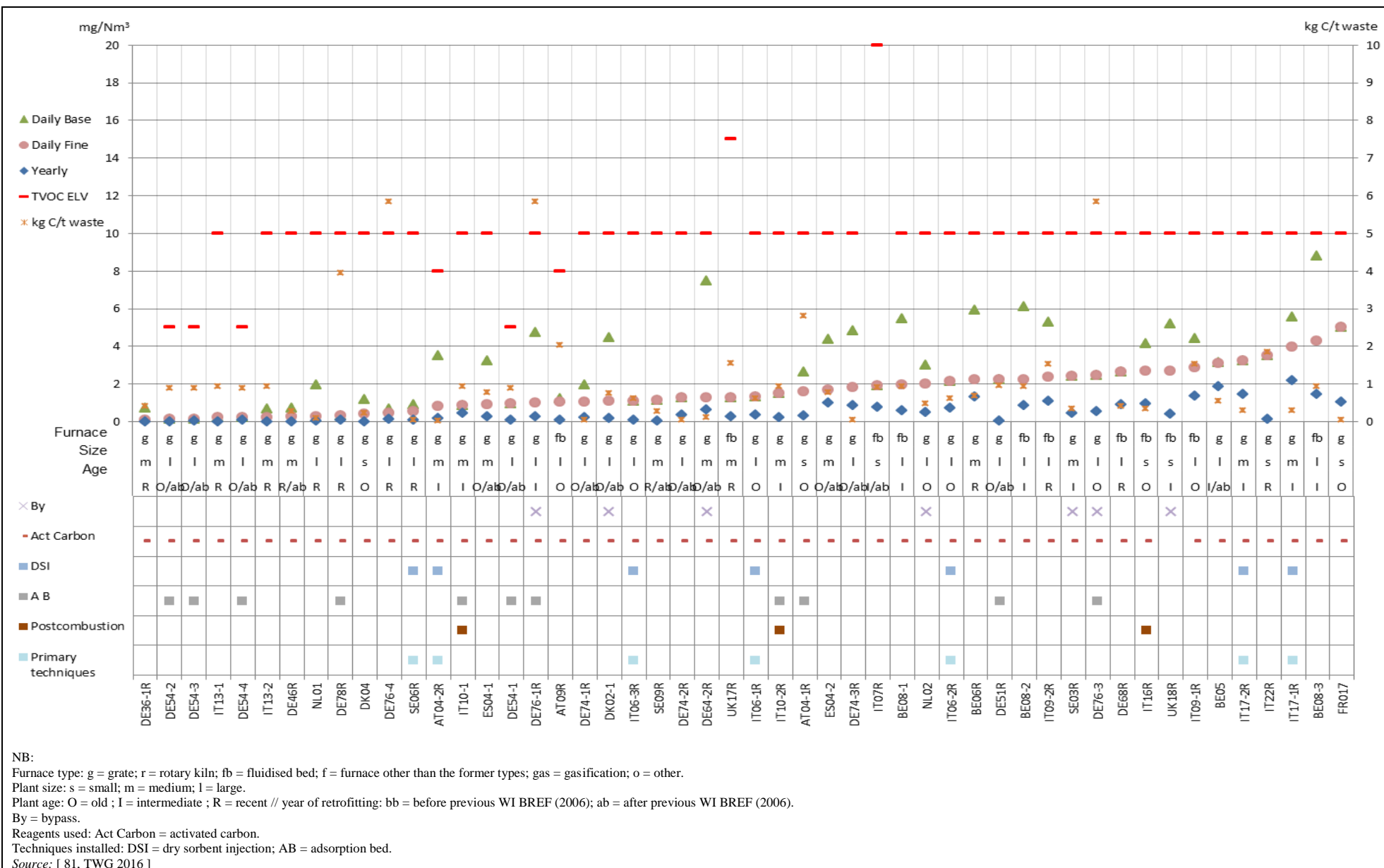

Figure 8.27: Daily and yearly average emission levels for continuously monitored TVOC emissions to air from reference lines incinerating predominantly ONHW

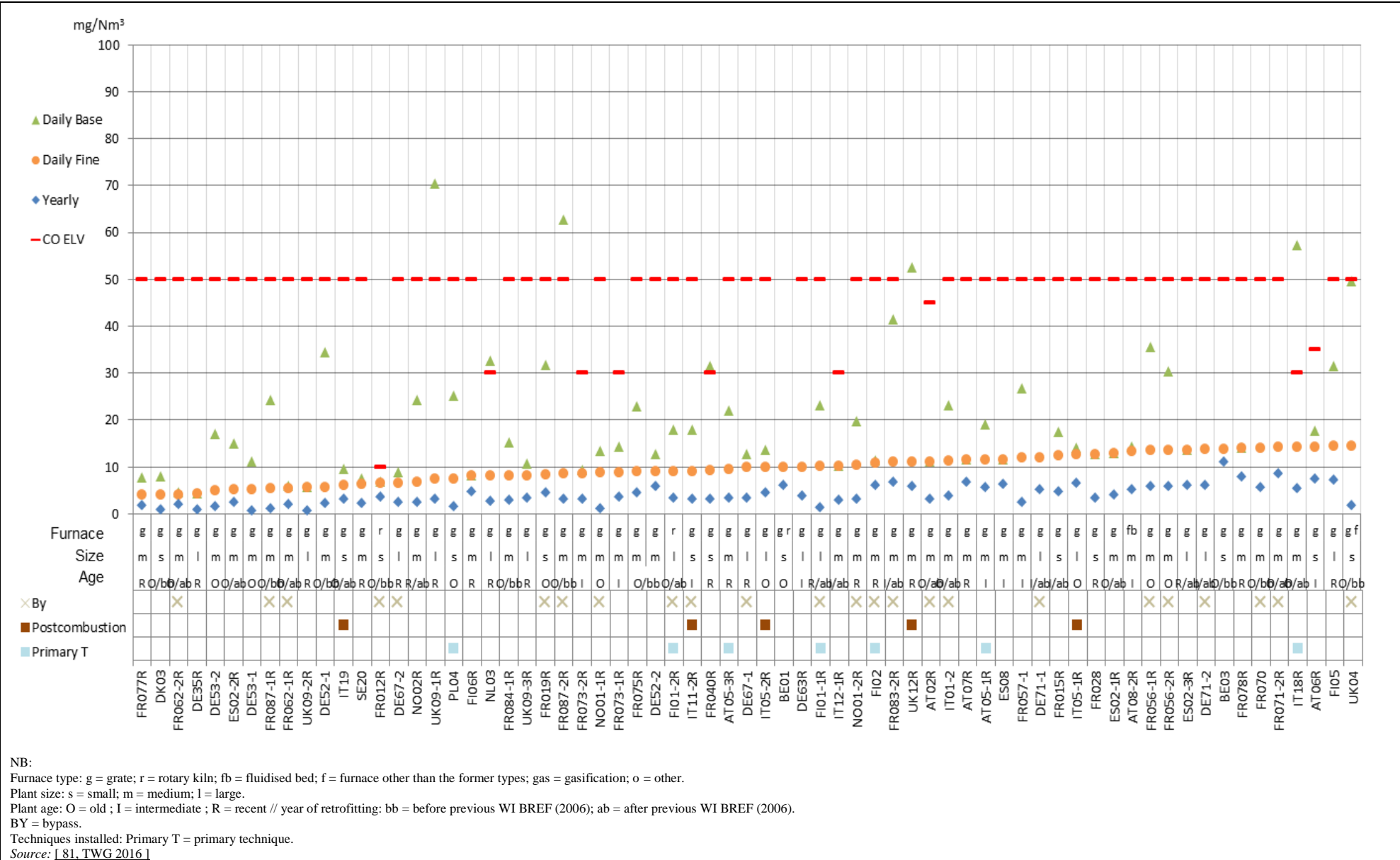

Figure 8.28: Daily and yearly average emission levels for continuously monitored CO emissions to air from reference lines incinerating predominantly MSW (1/3)

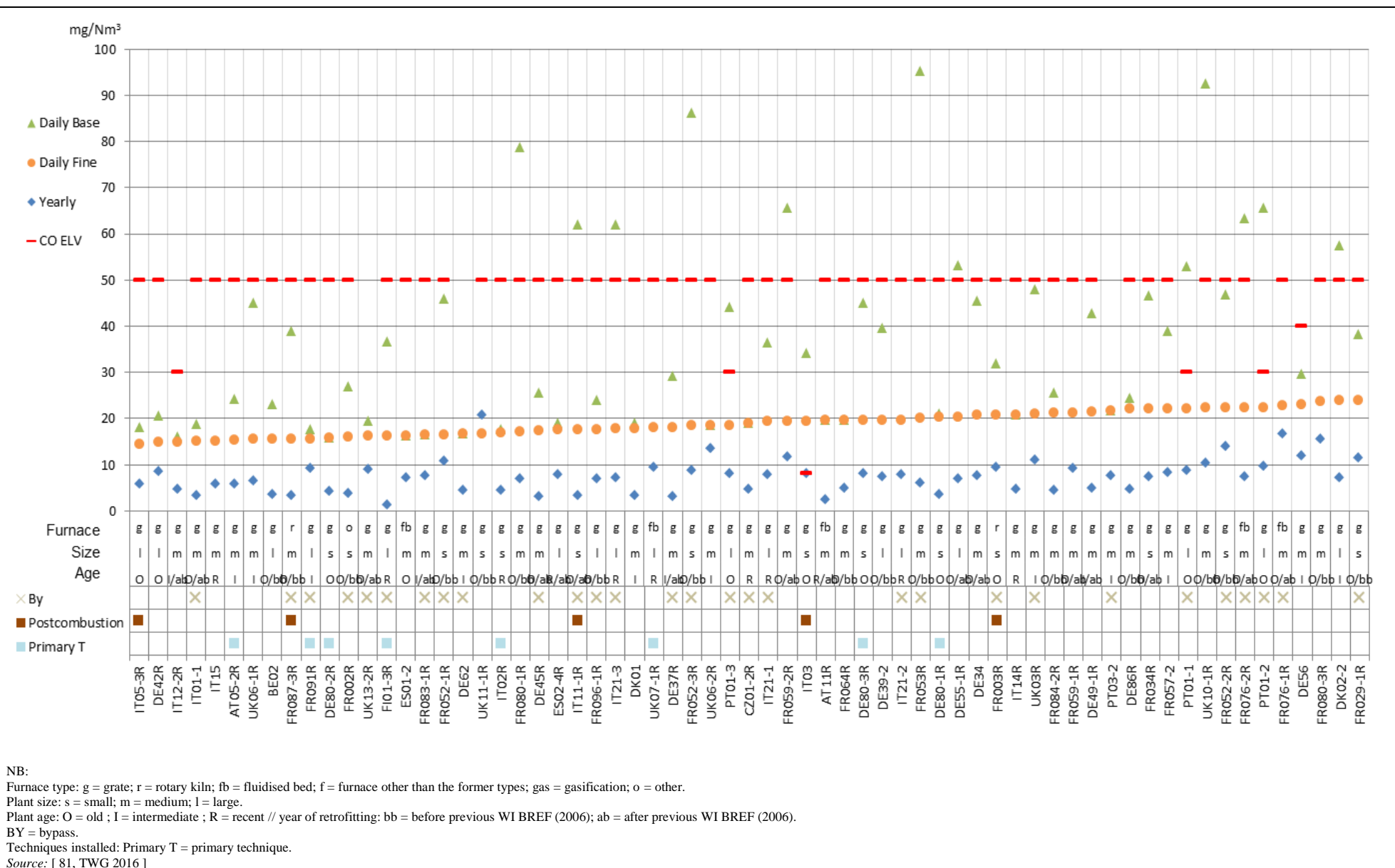

Figure 8.29: Daily and yearly average emission levels for continuously monitored CO emissions to air from reference lines incinerating predominantly MSW (2/3)

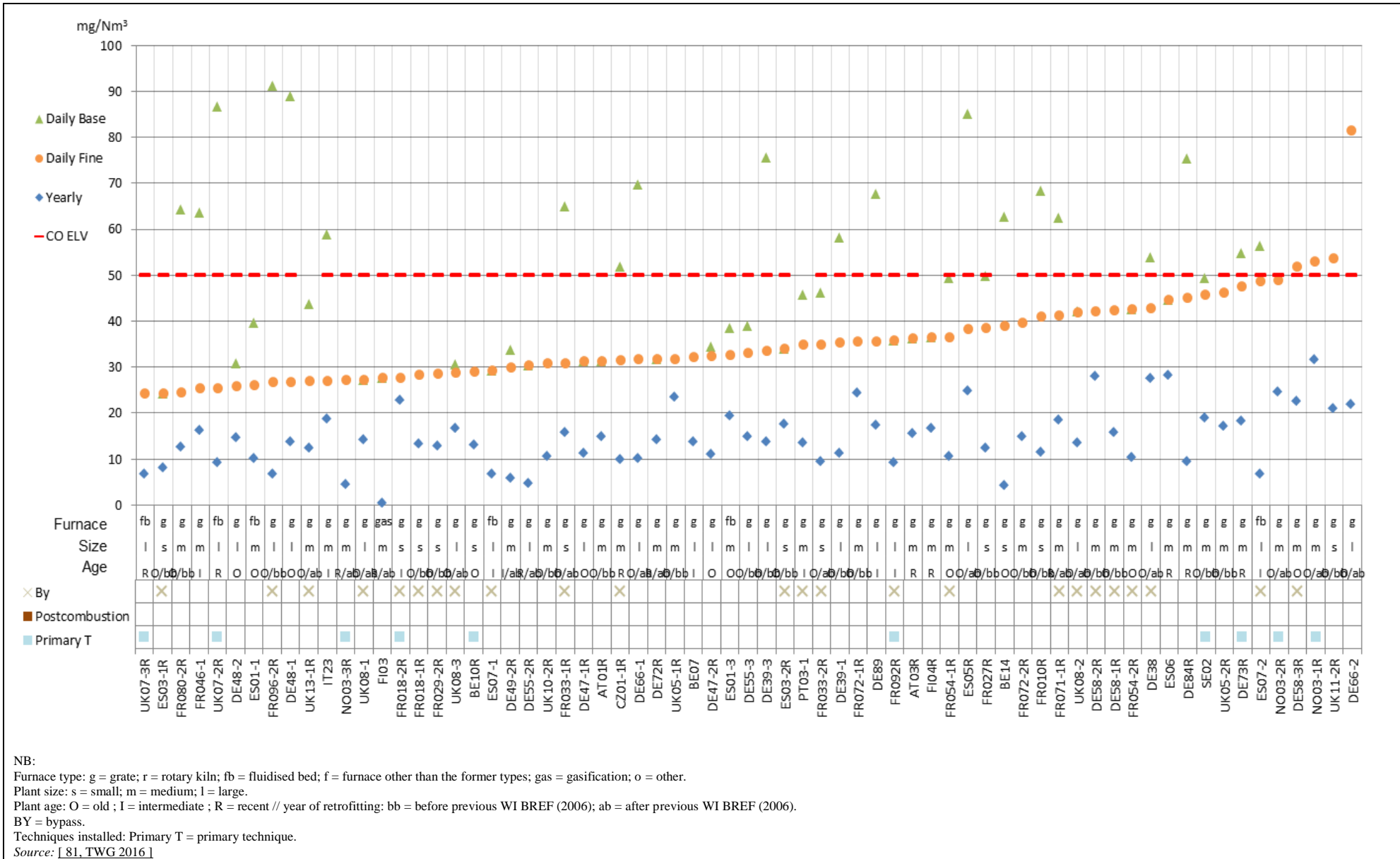

Figure 8.30: Daily and yearly average emission levels for continuously monitored CO emissions to air from reference lines incinerating predominantly MSW (3/3)

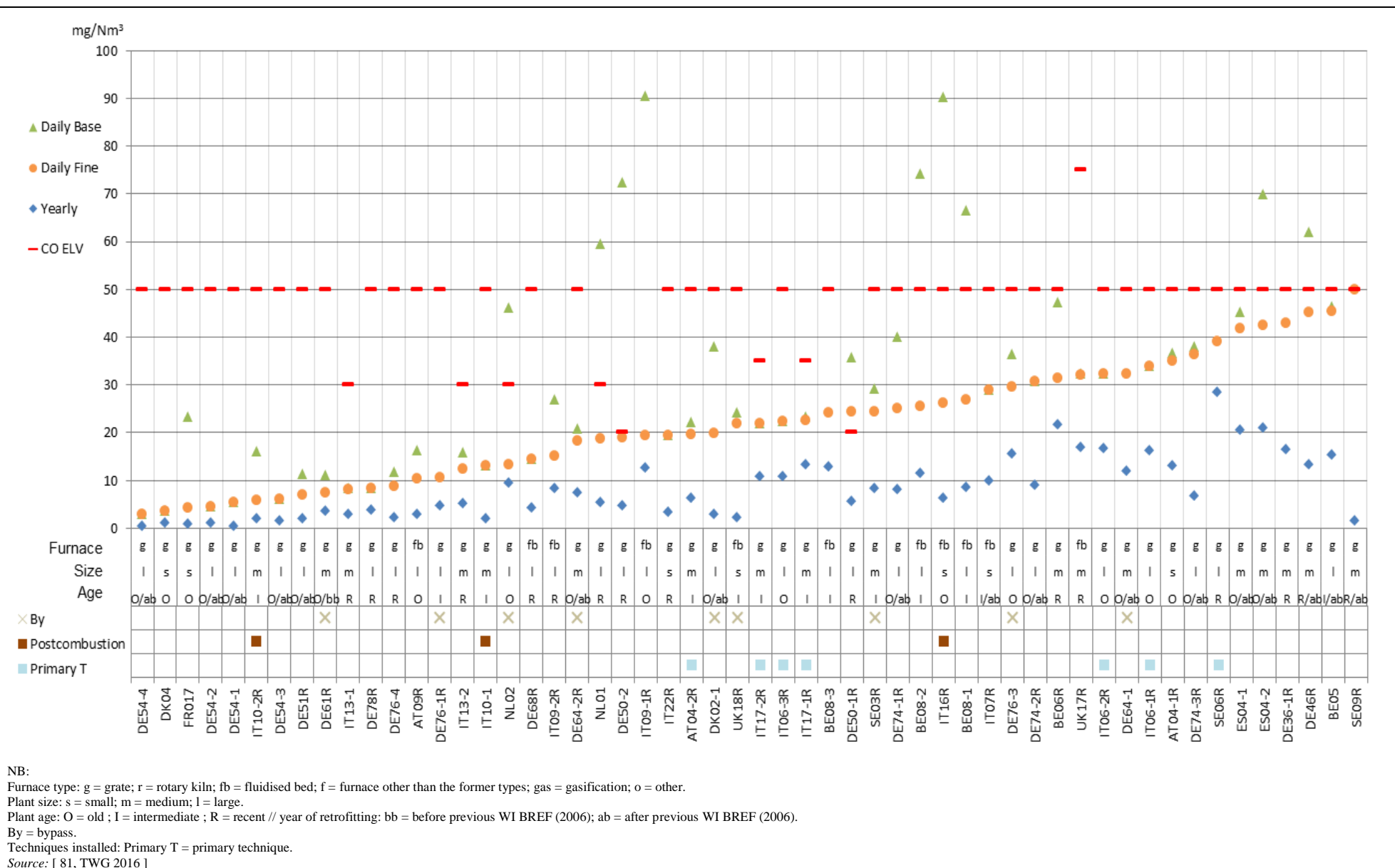

Figure 8.31: Daily and yearly average emission levels for continuously monitored CO emissions to air from reference lines incinerating predominantly ONHW

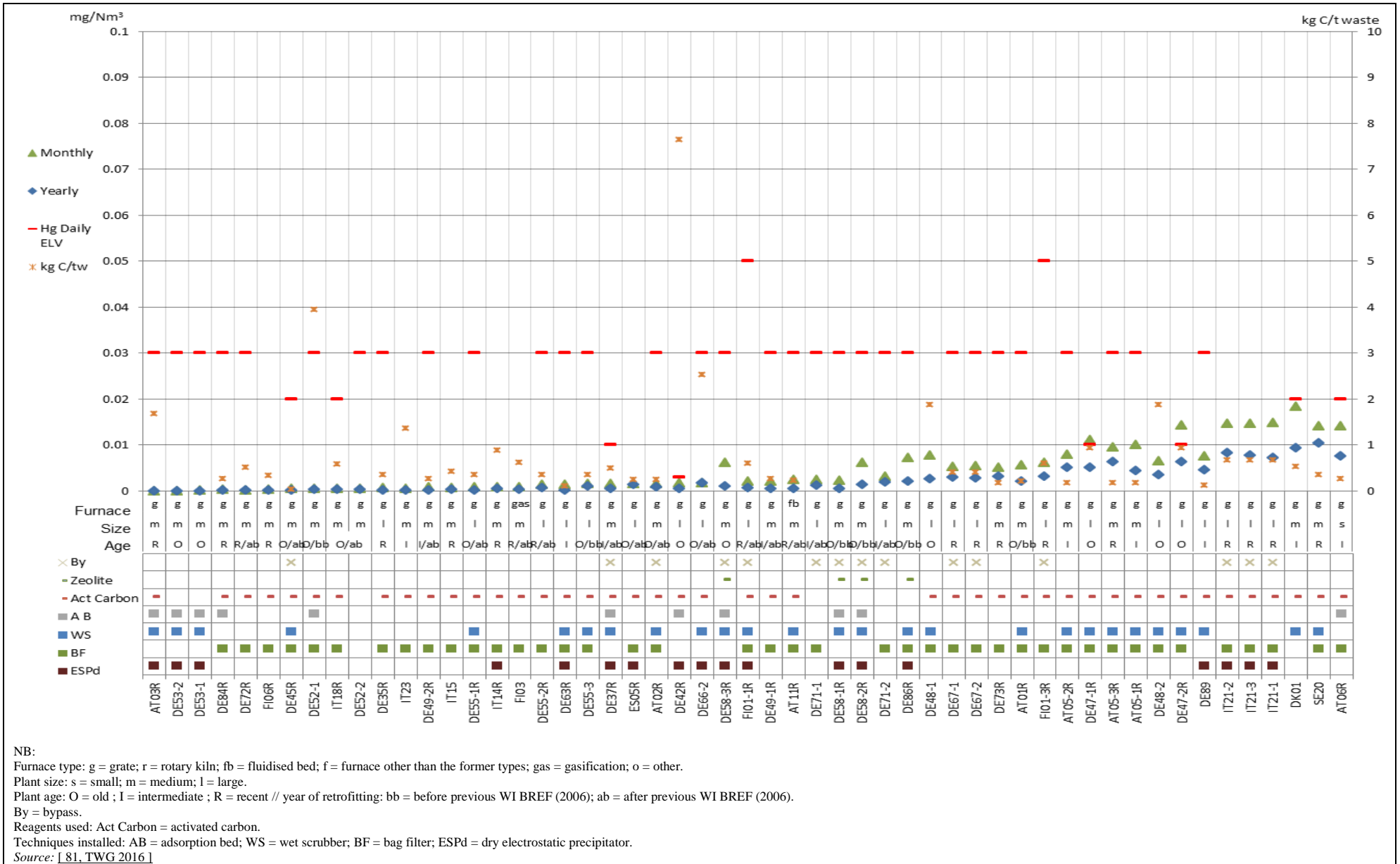

Figure 8.32: Daily and yearly average emission levels for continuously monitored Hg emissions to air from reference lines incinerating predominantly MSW

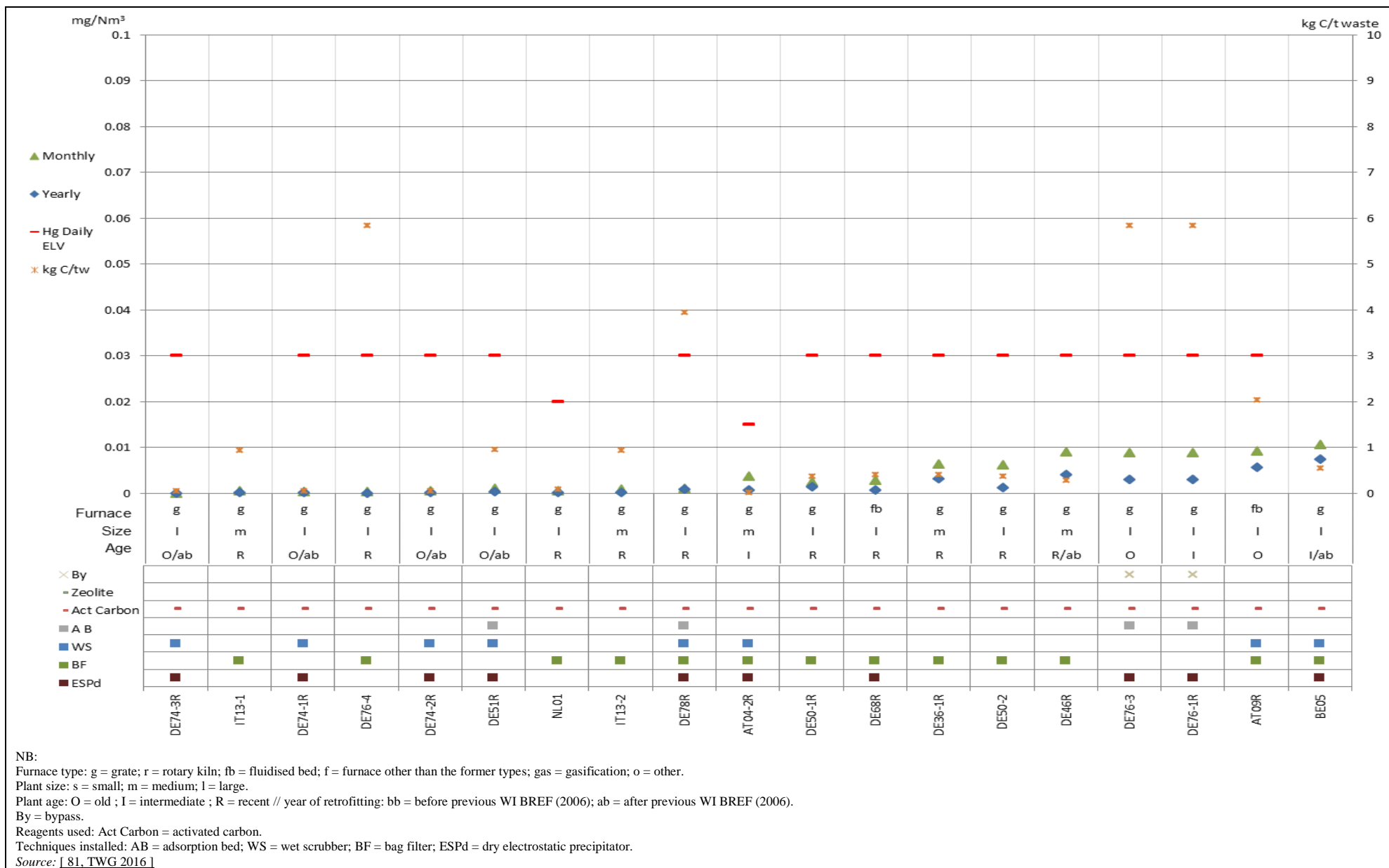

Figure 8.33: Daily and yearly average emission levels for continuously monitored Hg emissions to air from reference lines incinerating predominantly ONHW

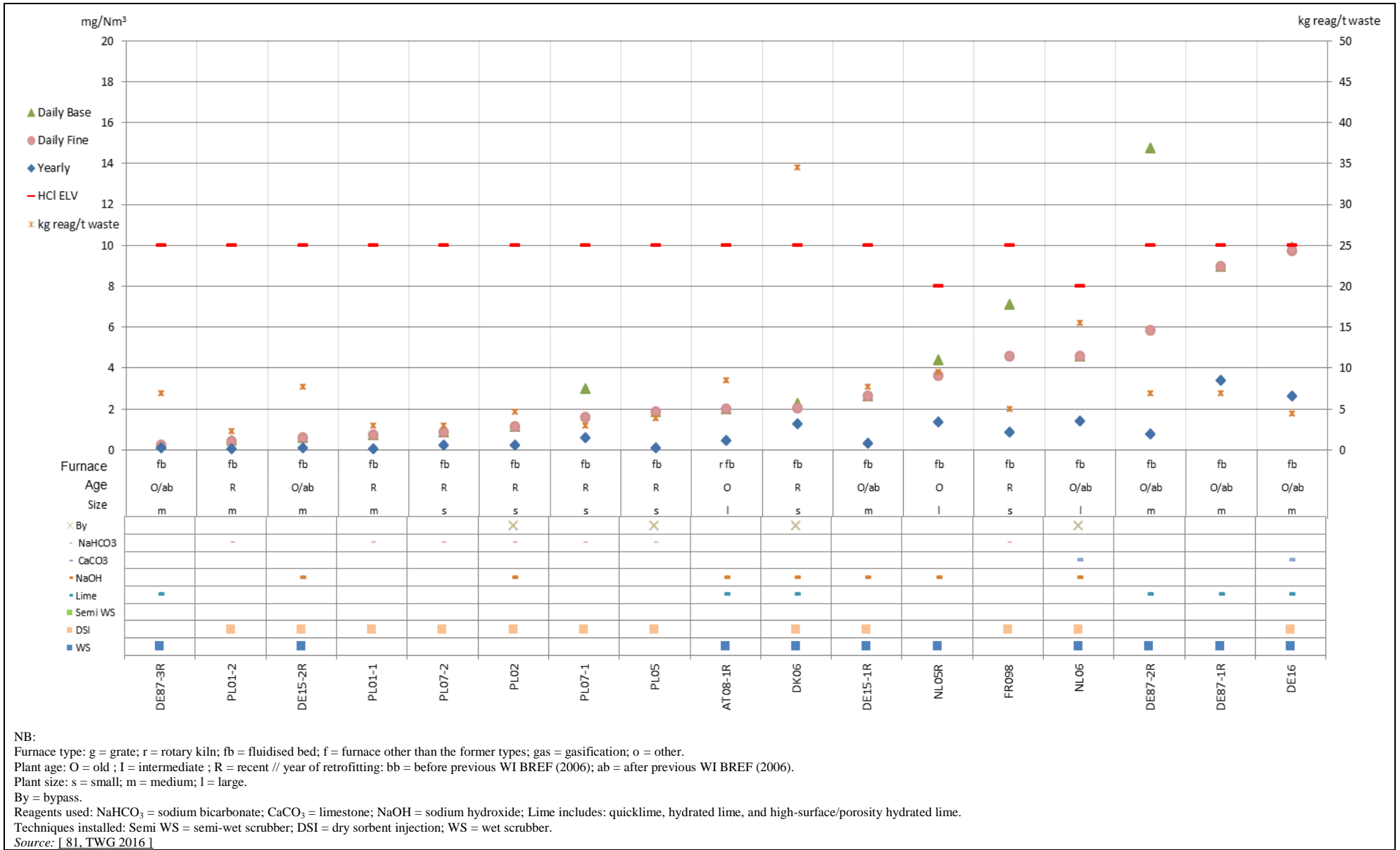

Figure 8.34: Daily and yearly average emission levels for continuously monitored HCl emissions to air from reference lines incinerating predominantly SS

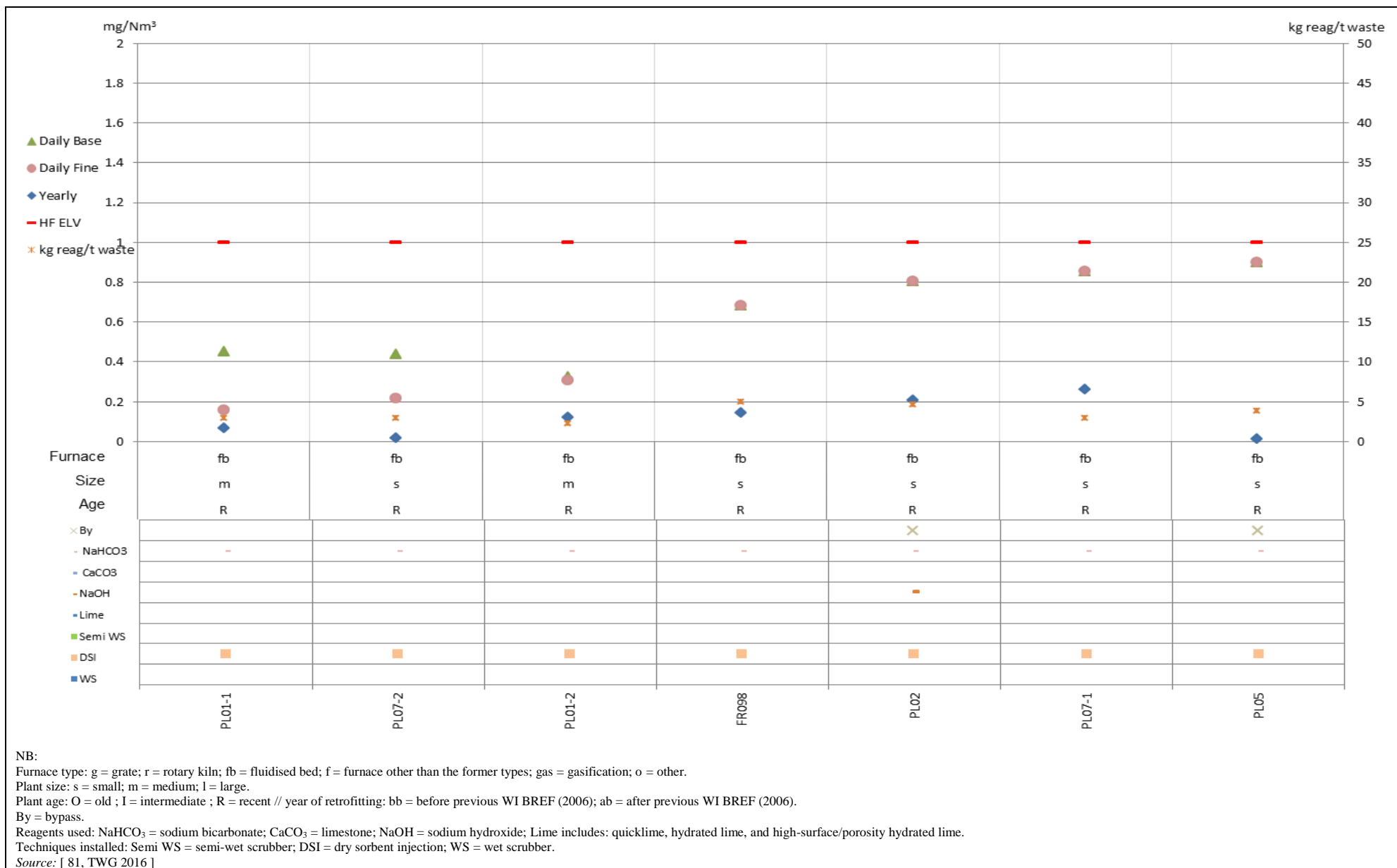

Figure 8.35: Daily and yearly average emission levels for continuously monitored HF emissions to air from reference lines incinerating predominantly SS

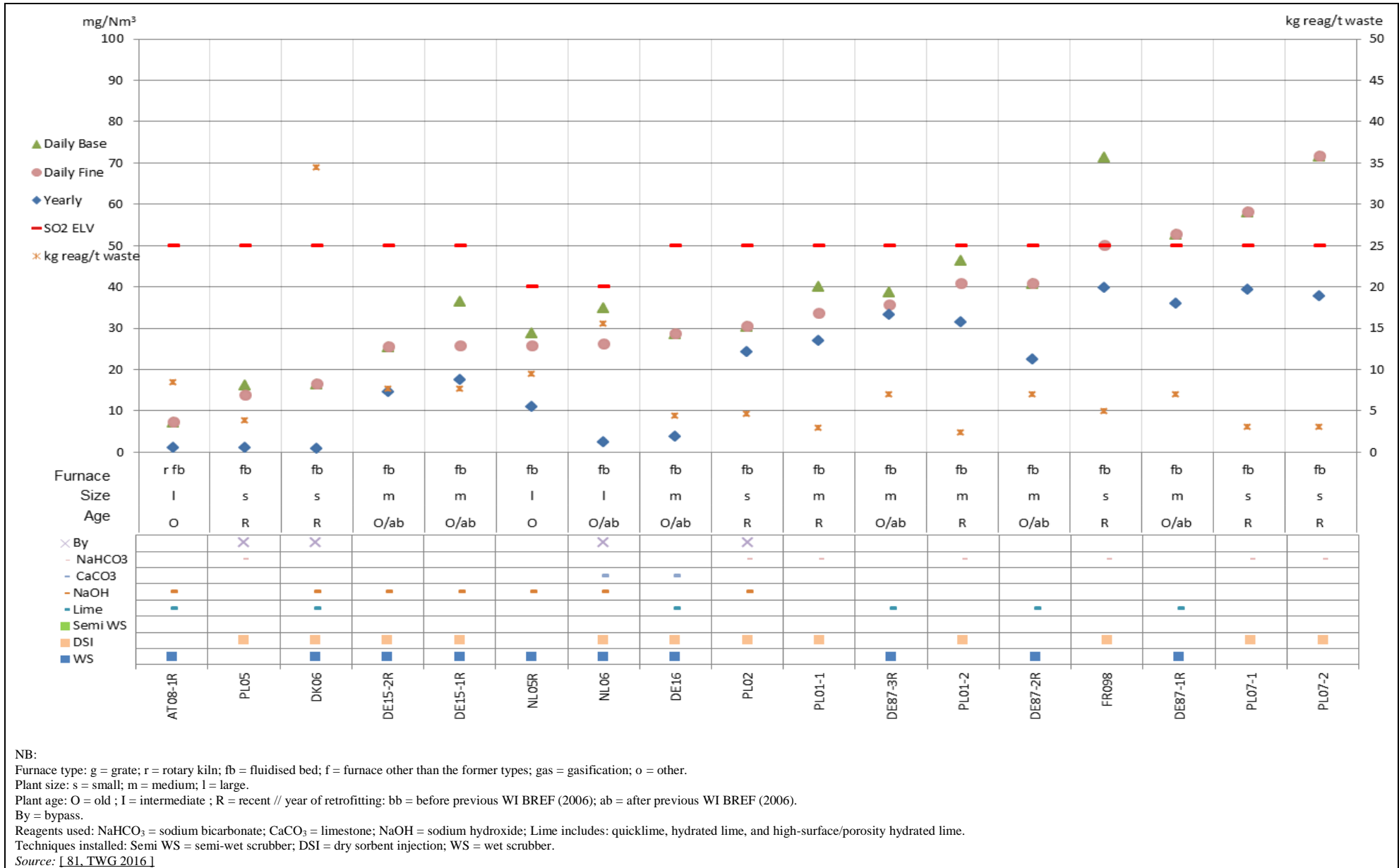

Figure 8.36: Daily and yearly average emission levels for continuously monitored SO₂ emissions to air from reference lines incinerating predominantly SS

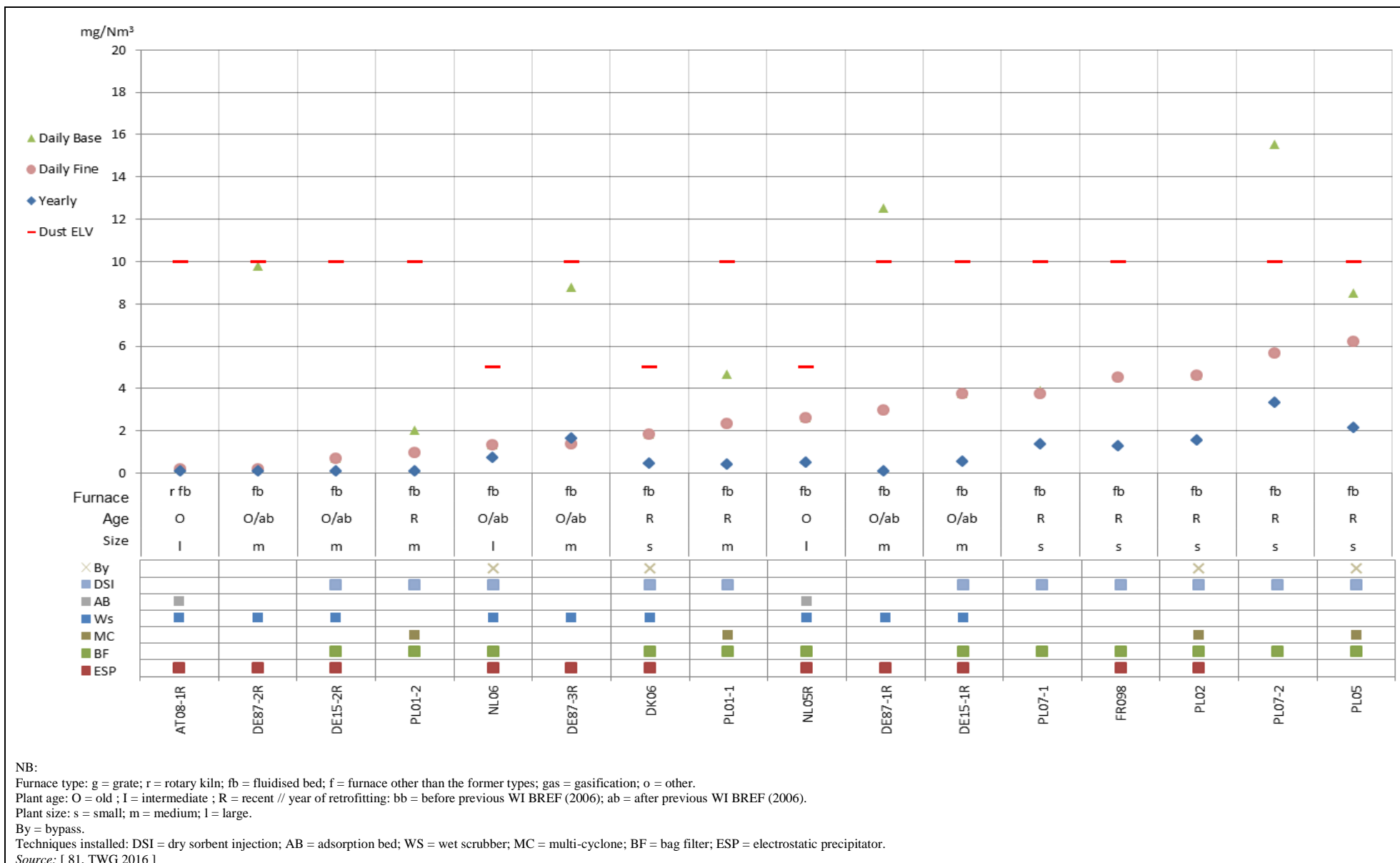

Figure 8.37: Daily and yearly average emission levels for continuously monitored dust emissions to air from reference lines incinerating predominantly SS

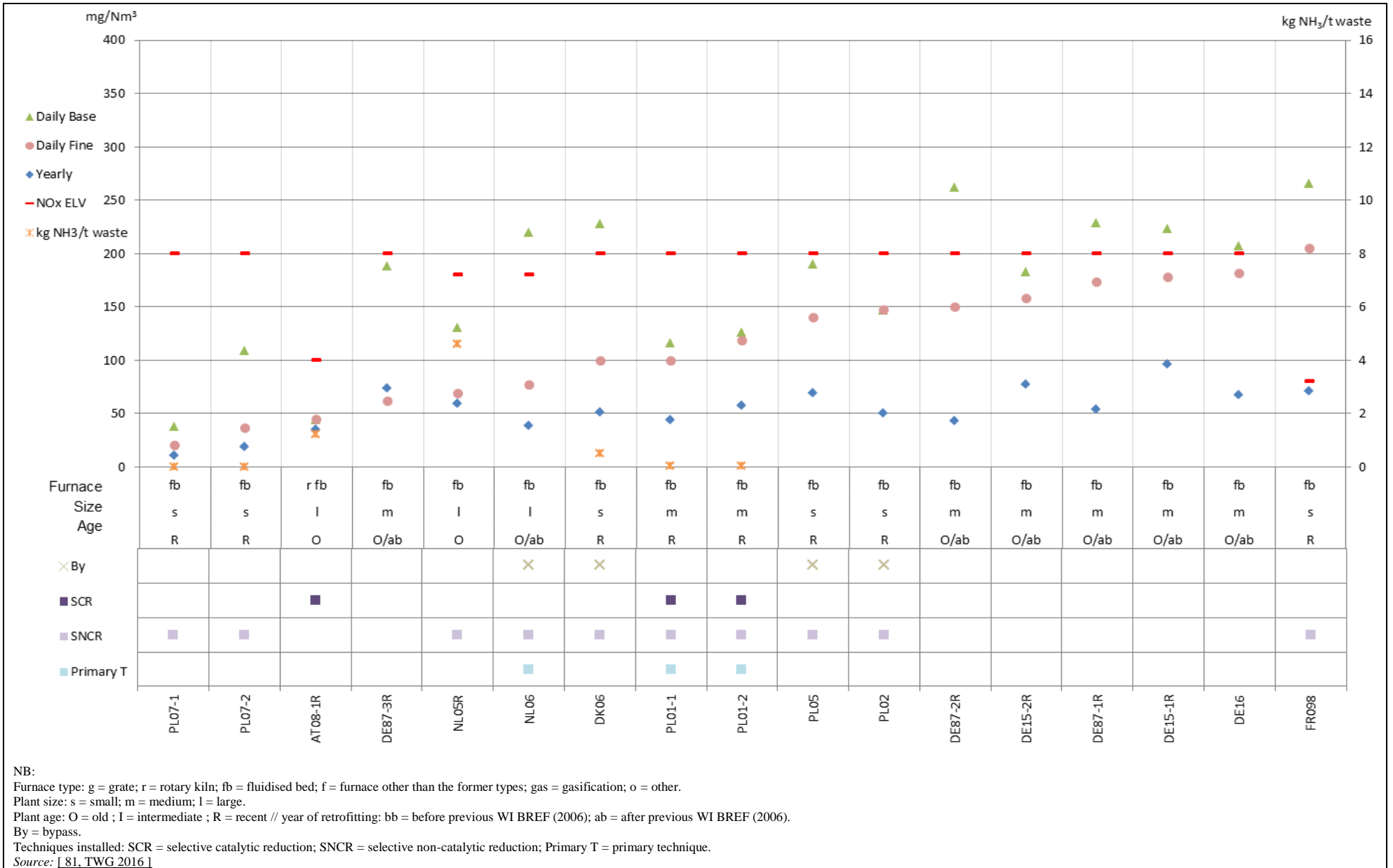

Figure 8.38: Daily and yearly average emission levels for continuously monitored NO_x emissions to air from reference lines incinerating predominantly SS

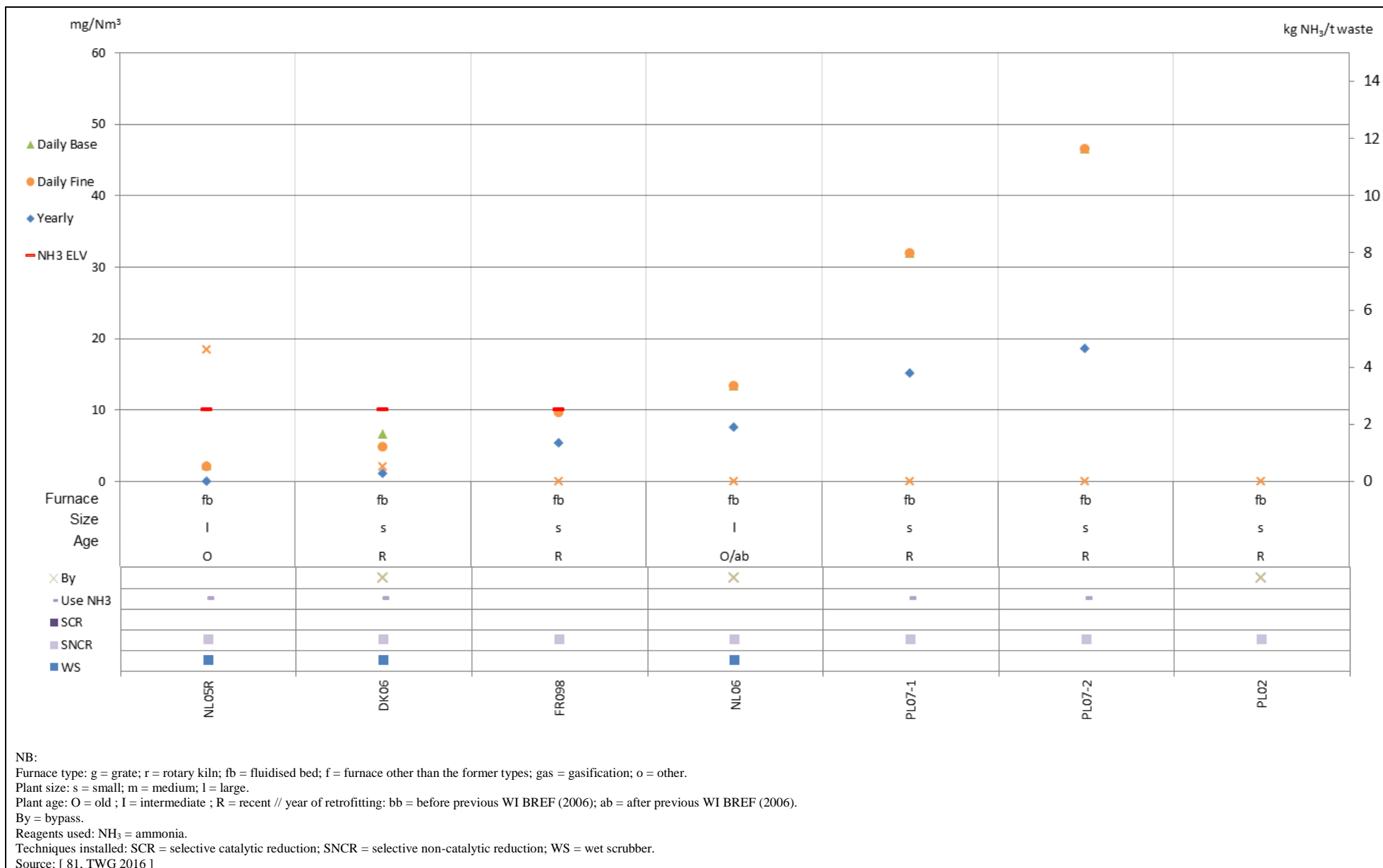

Figure 8.39: Daily and yearly average emission levels for continuously monitored NH₃ emissions to air from reference lines incinerating predominantly SS

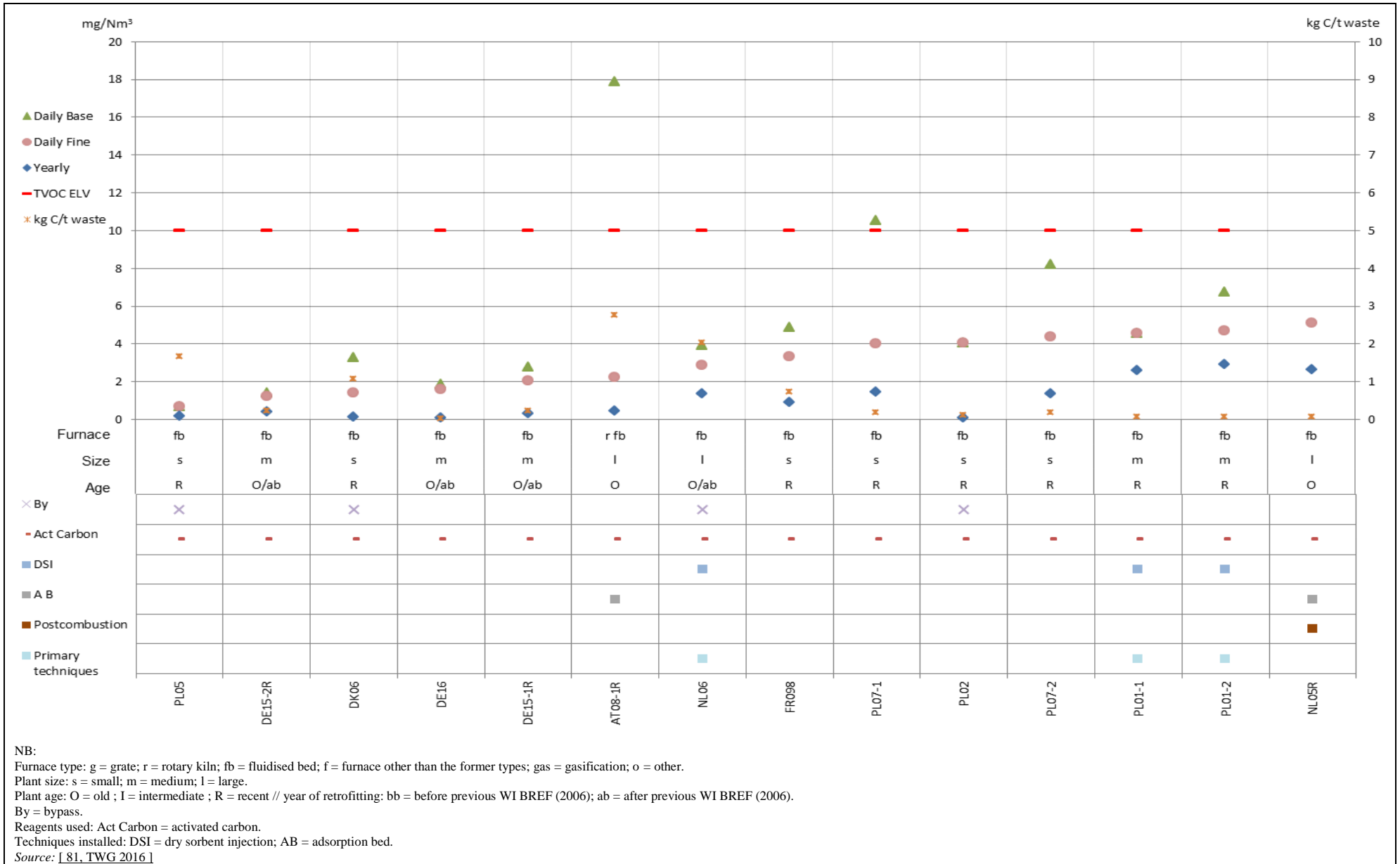

Figure 8.40: Daily and yearly average emission levels for continuously monitored TVOC emissions to air from reference lines incinerating predominantly SS

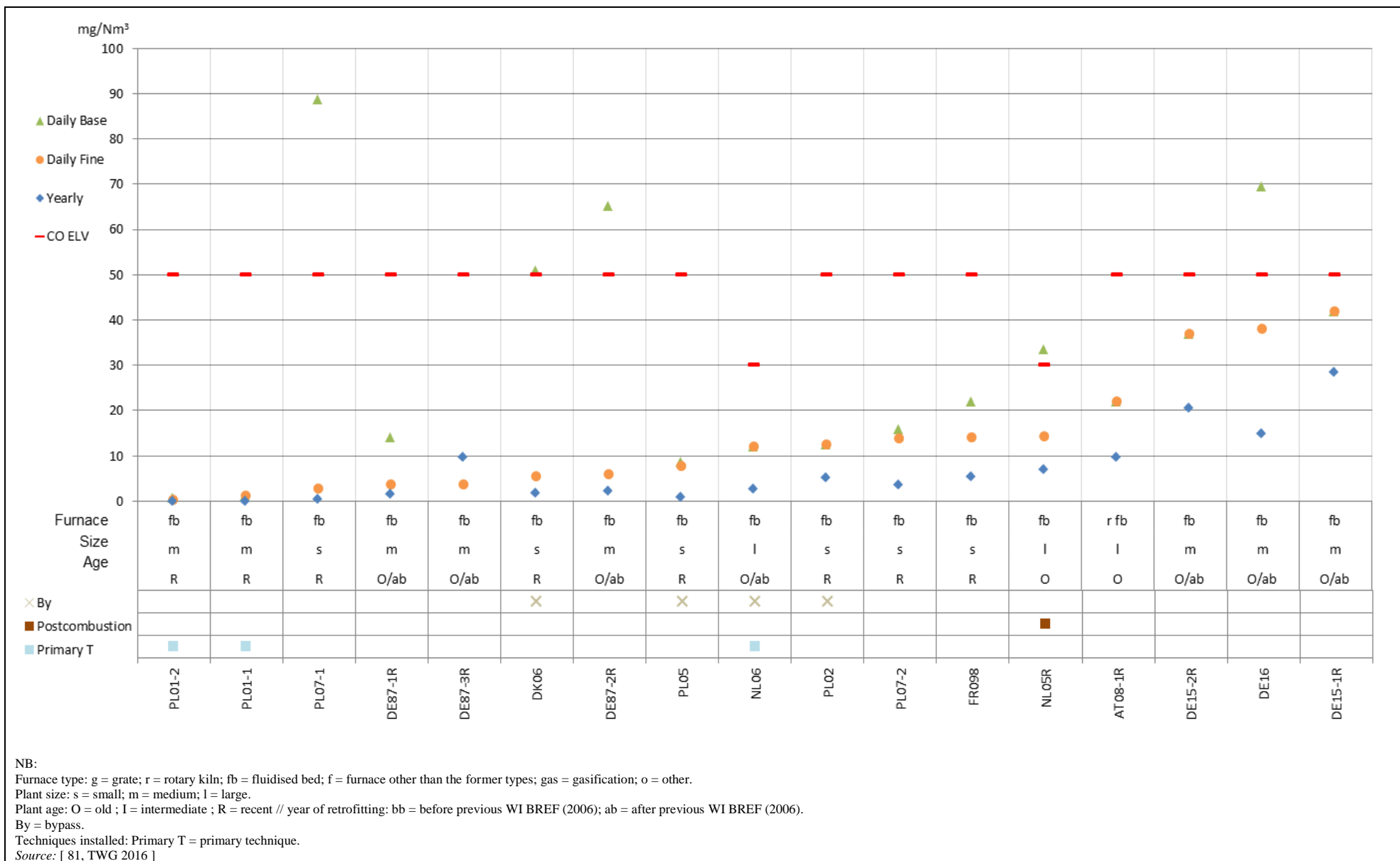

Figure 8.41: Daily and yearly average emission levels for continuously monitored CO emissions to air from reference lines incinerating predominantly SS

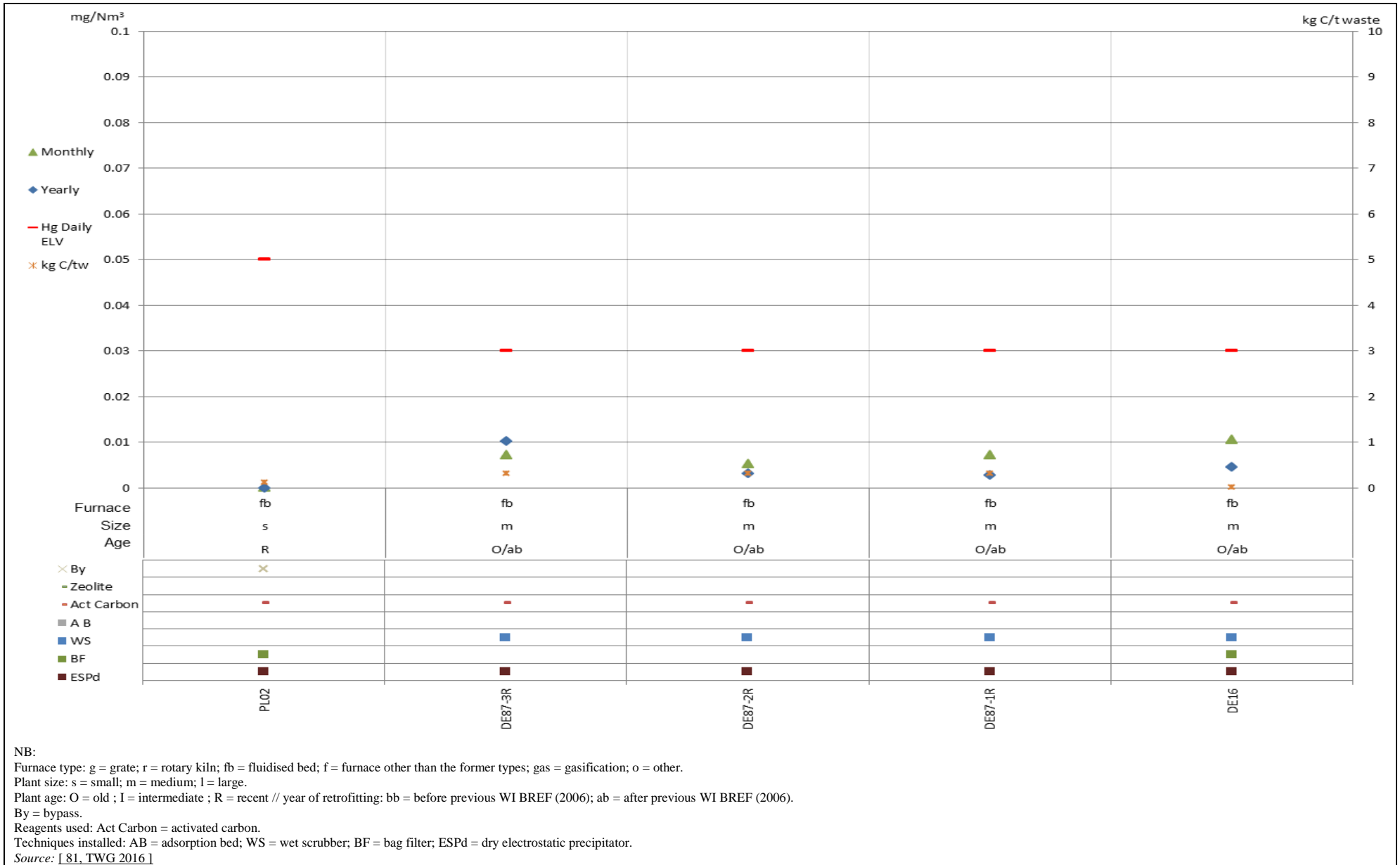

Figure 8.42: Daily and yearly average emission levels for continuously monitored Hg emissions to air from reference lines incinerating predominantly SS

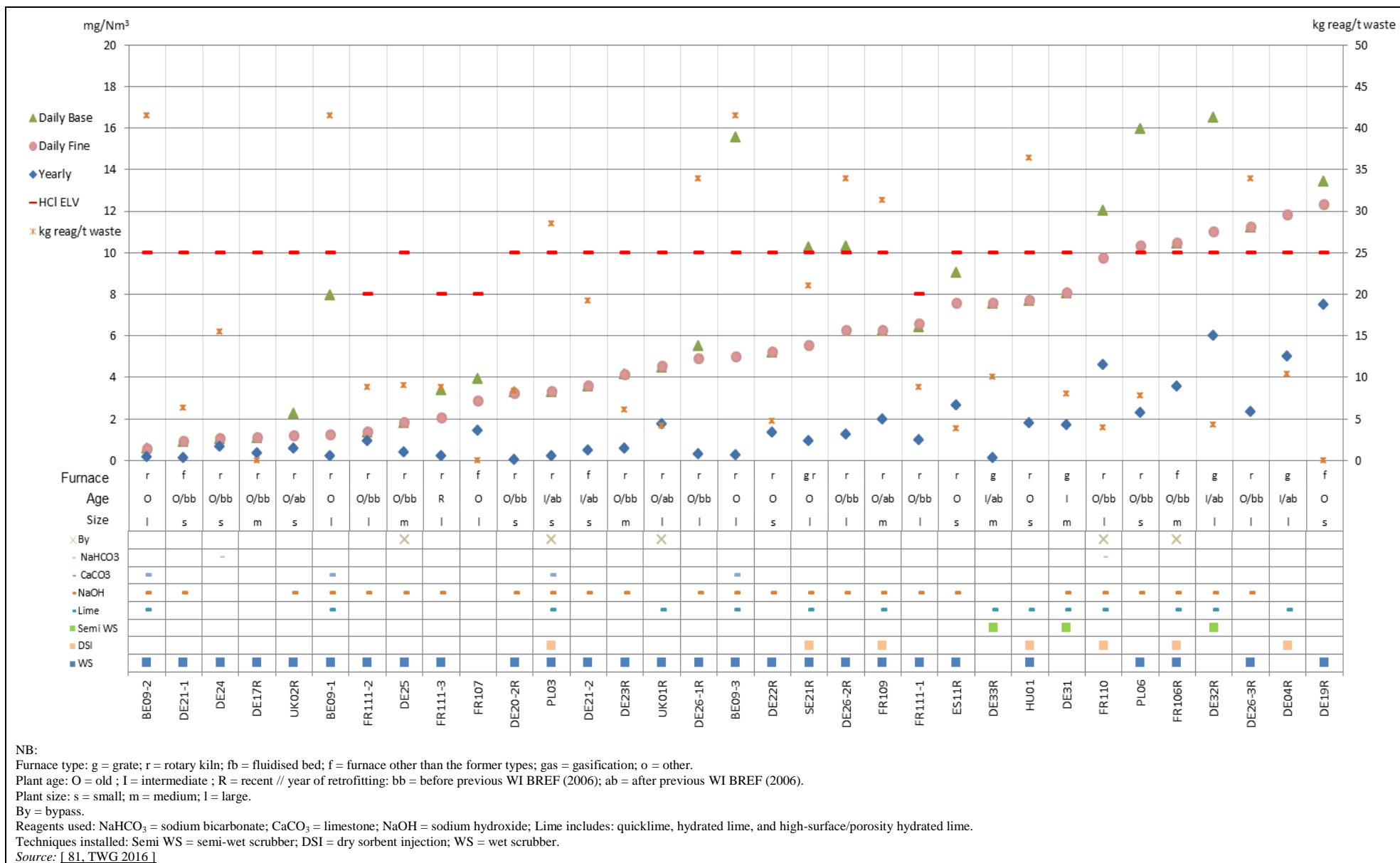

Figure 8.43: Daily and yearly average emission levels for continuously monitored HCl emissions to air from reference lines incinerating predominantly HW

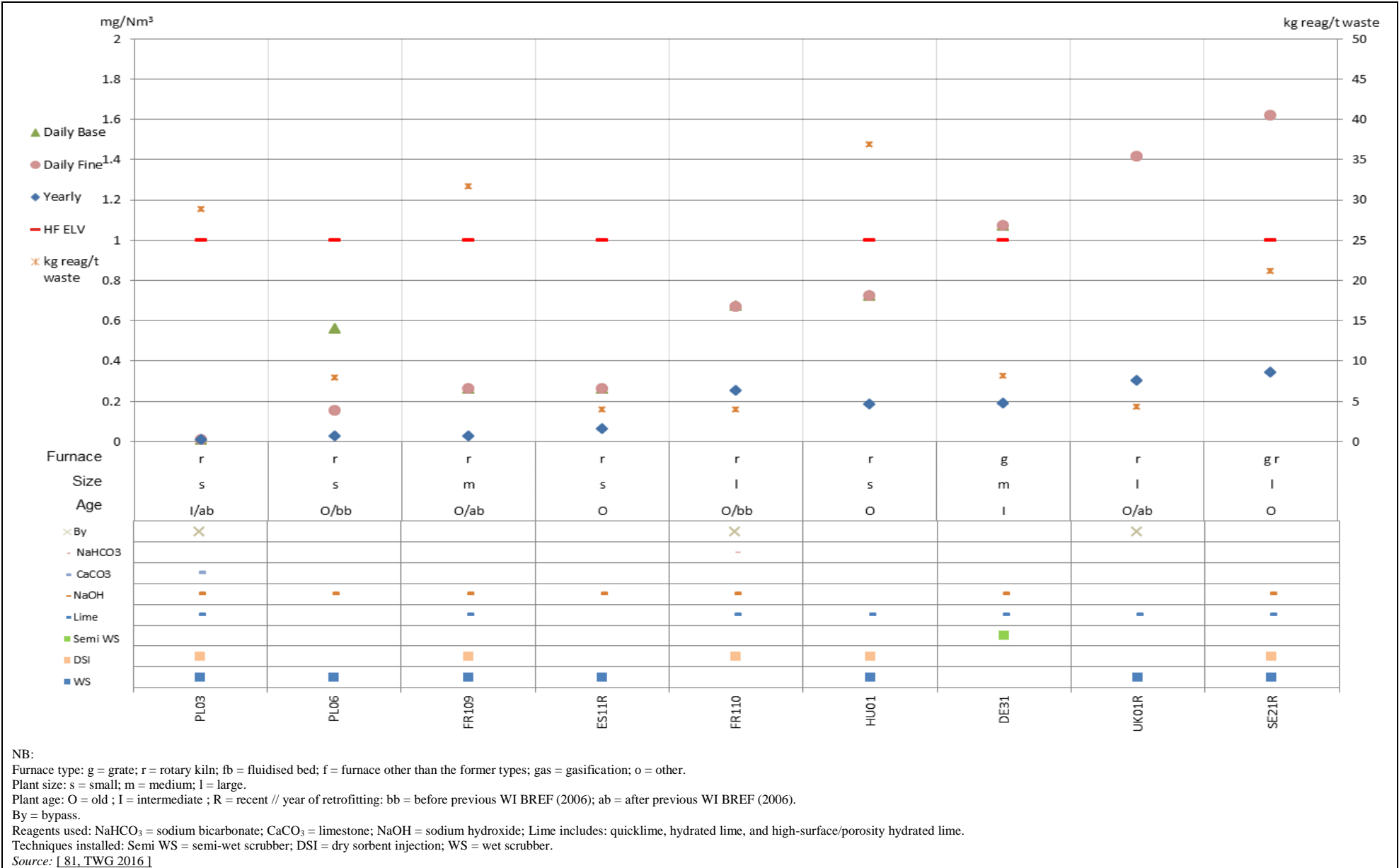
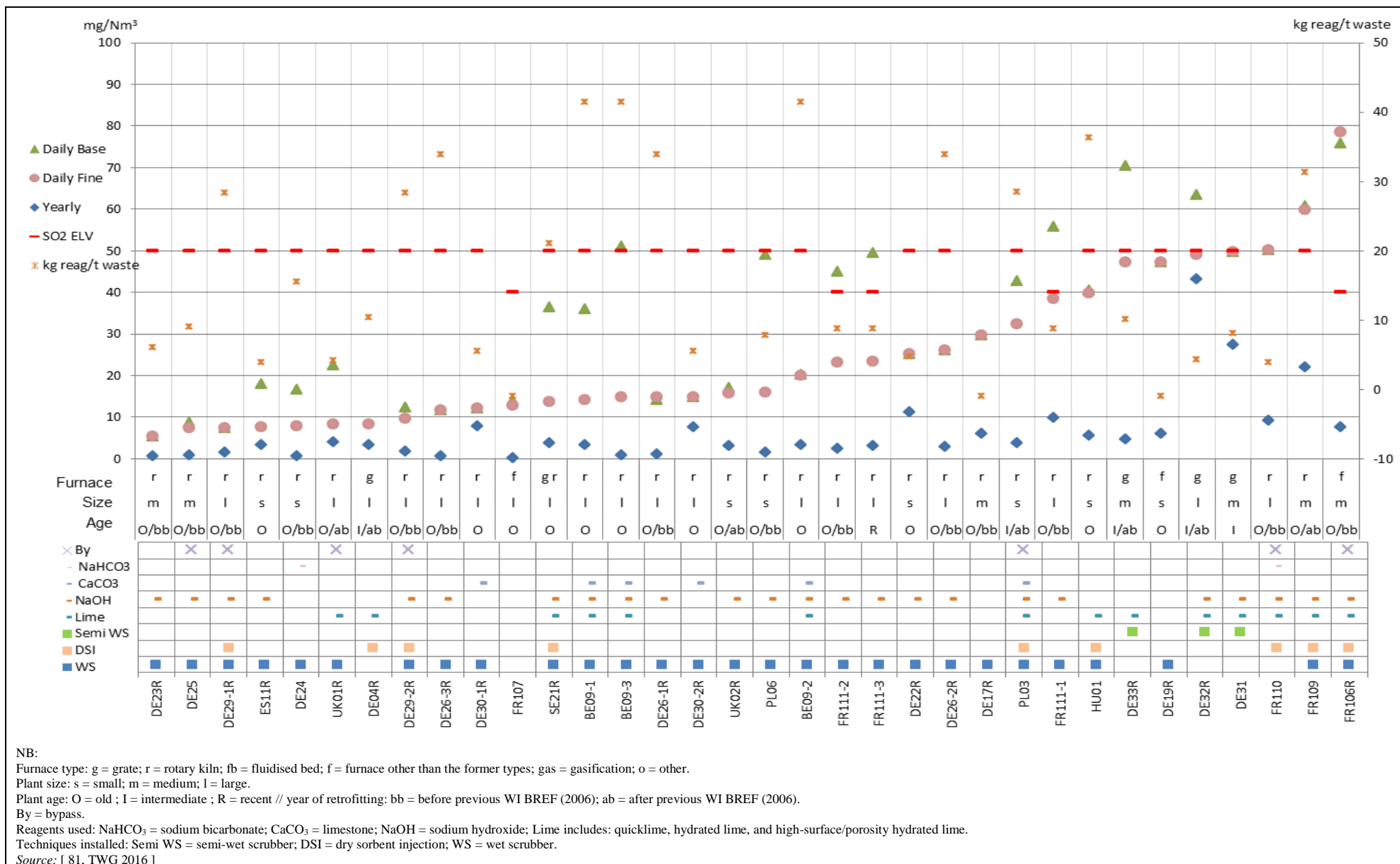

Figure 8.44: Daily and yearly average emission levels for continuously monitored HF emissions to air from reference lines incinerating predominantly HW



NB:
 Furnace type: g = grate; r = rotary kiln; fb = fluidised bed; f = furnace other than the former types; gas = gasification; o = other.
 Plant size: s = small; m = medium; l = large.
 Plant age: O = old ; I = intermediate ; R = recent // year of retrofitting; bb = before previous WI BREF (2006); ab = after previous WI BREF (2006).
 By = bypass.
 Reagents used: NaHCO₃ = sodium bicarbonate; CaCO₃ = limestone; NaOH = sodium hydroxide; Lime includes: quicklime, hydrated lime, and high-surface/porosity hydrated lime.
 Techniques installed: Semi WS = semi-wet scrubber; DSI = dry sorbent injection; WS = wet scrubber.
 Source: [81, TWG 2016]

Figure 8.45: Daily and yearly average emission levels for continuously monitored SO₂ emissions to air from reference lines incinerating predominantly HW

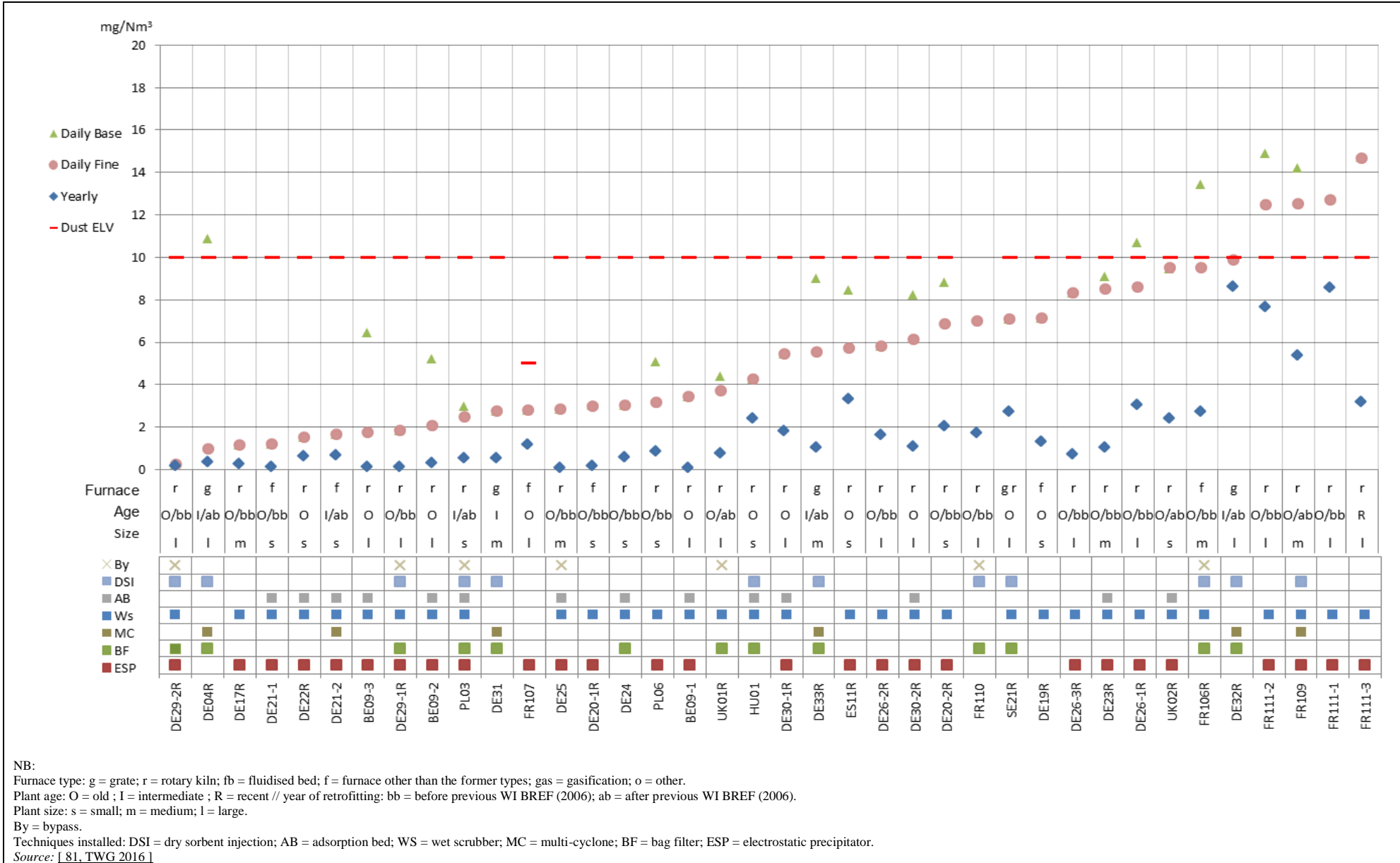

Figure 8.46: Daily and yearly average emission levels for continuously monitored dust emissions to air from reference lines incinerating predominantly HW

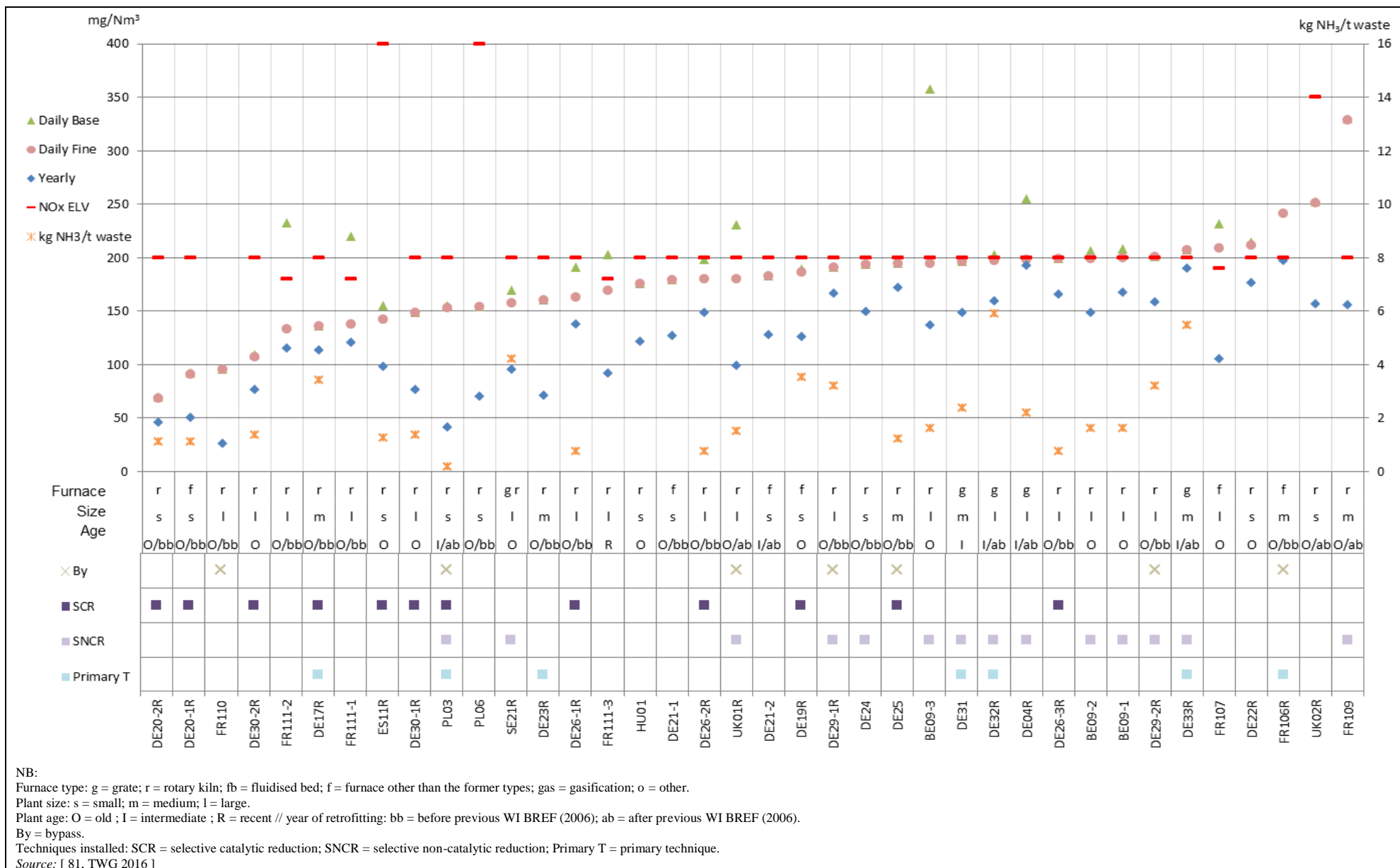

Figure 8.47: Daily and yearly average emission levels for continuously monitored NO_x emissions to air from reference lines incinerating predominantly HW

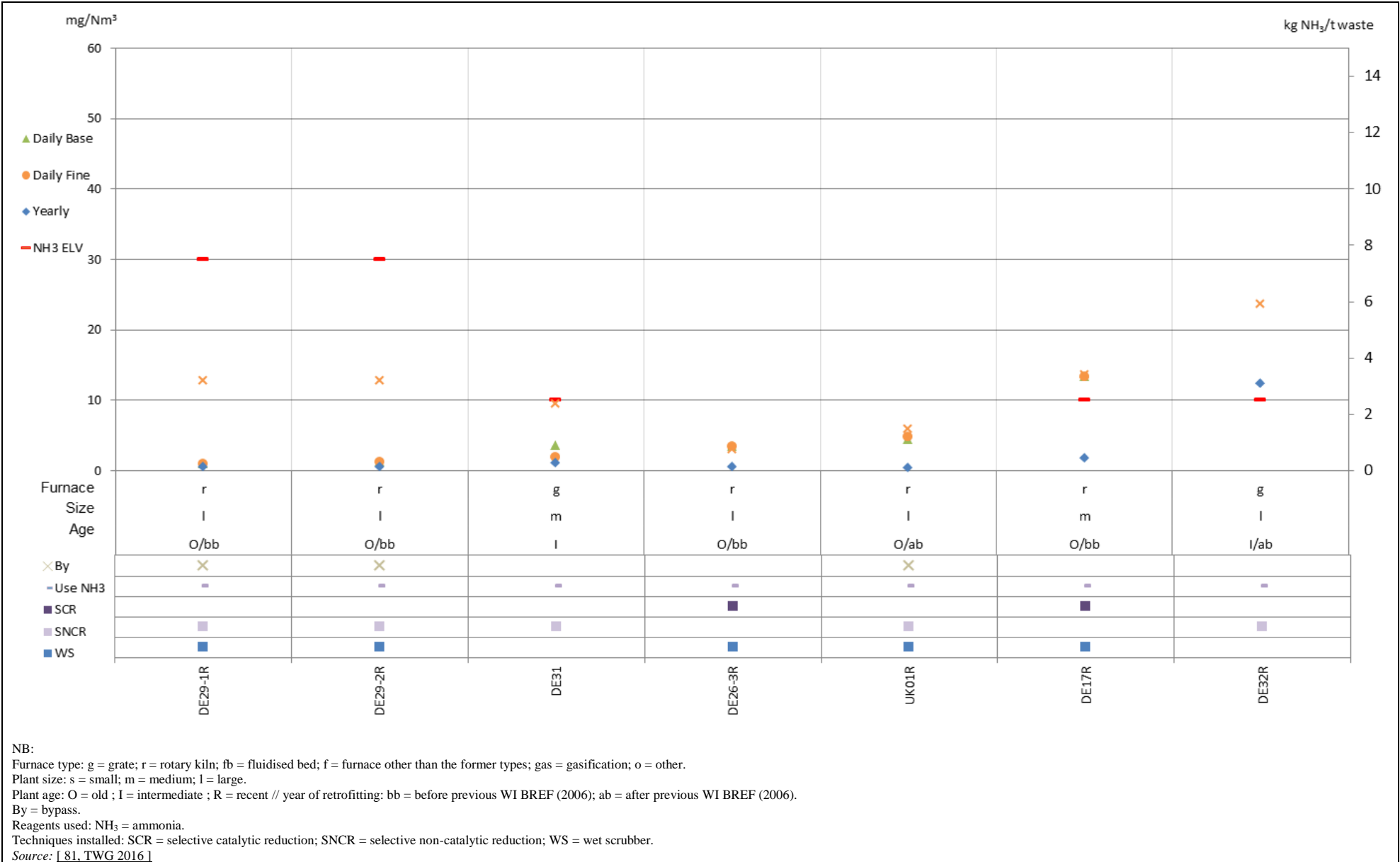

Figure 8.48: Daily and yearly average emission levels for continuously monitored NH₃ emissions to air from reference lines incinerating predominantly HW

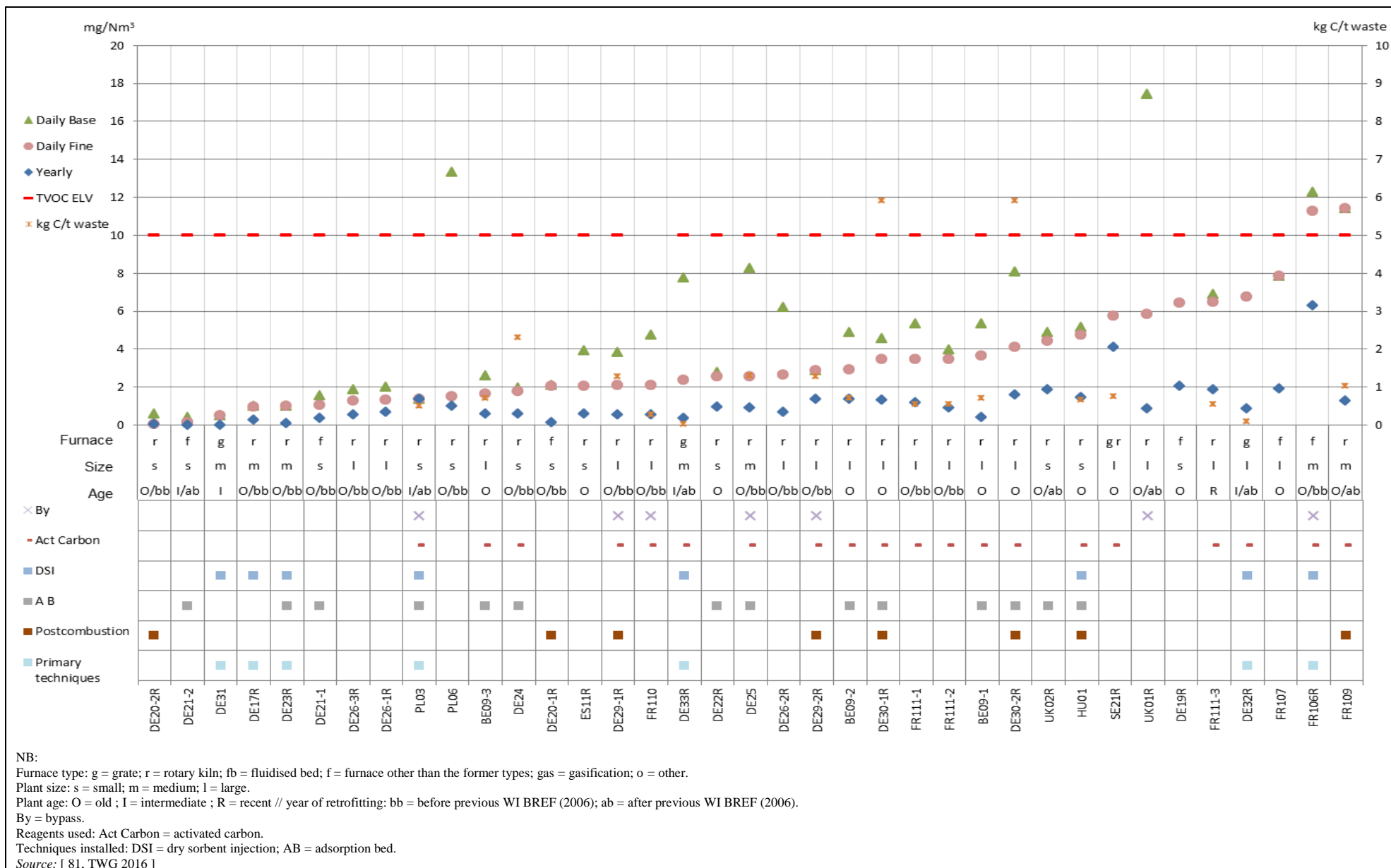

Figure 8.49: Daily and yearly average emission levels for continuously monitored TVOC emissions to air from reference lines incinerating predominantly HW

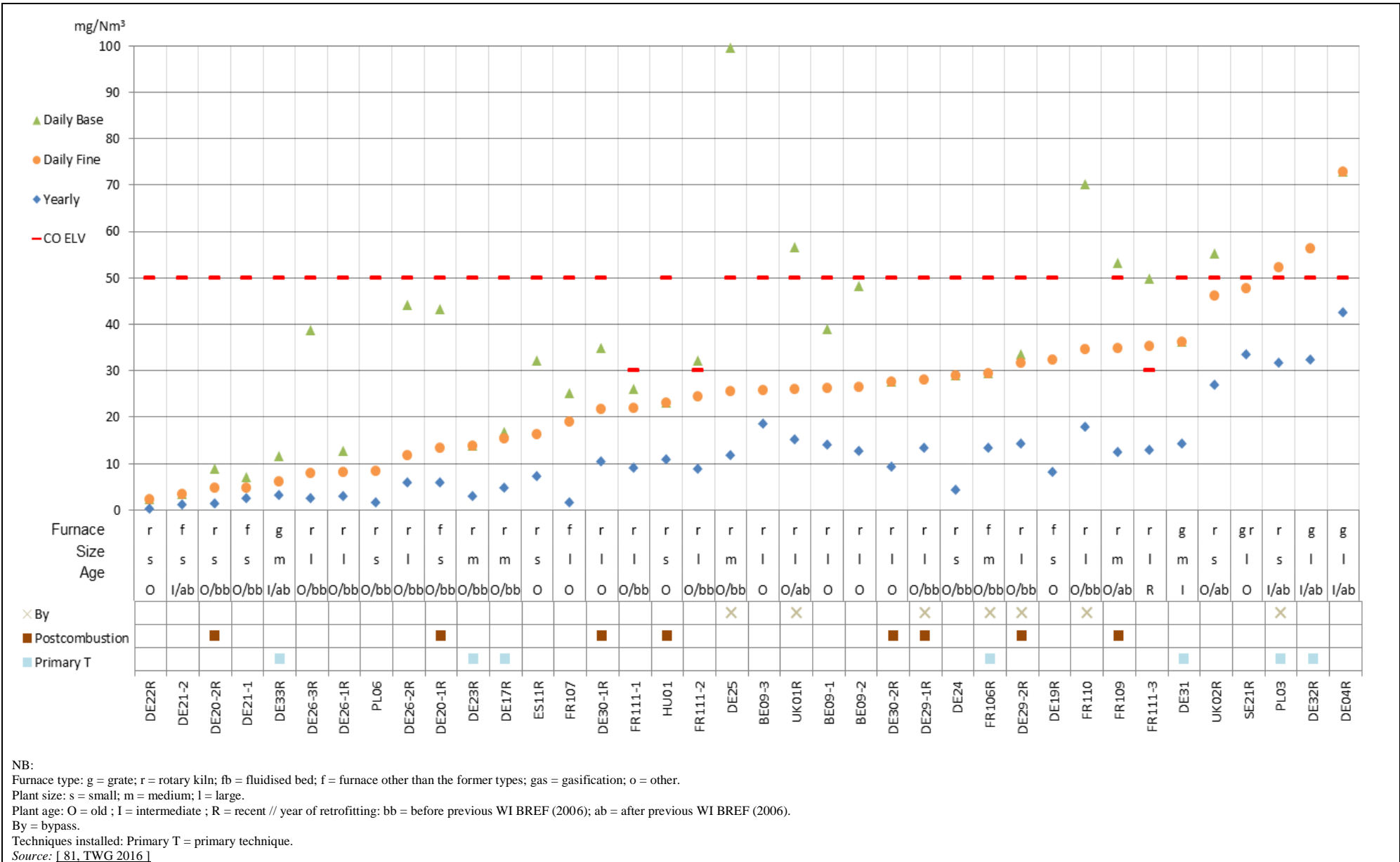

Figure 8.50: Daily and yearly average emission levels for continuously monitored CO emissions to air from reference lines incinerating predominantly HW

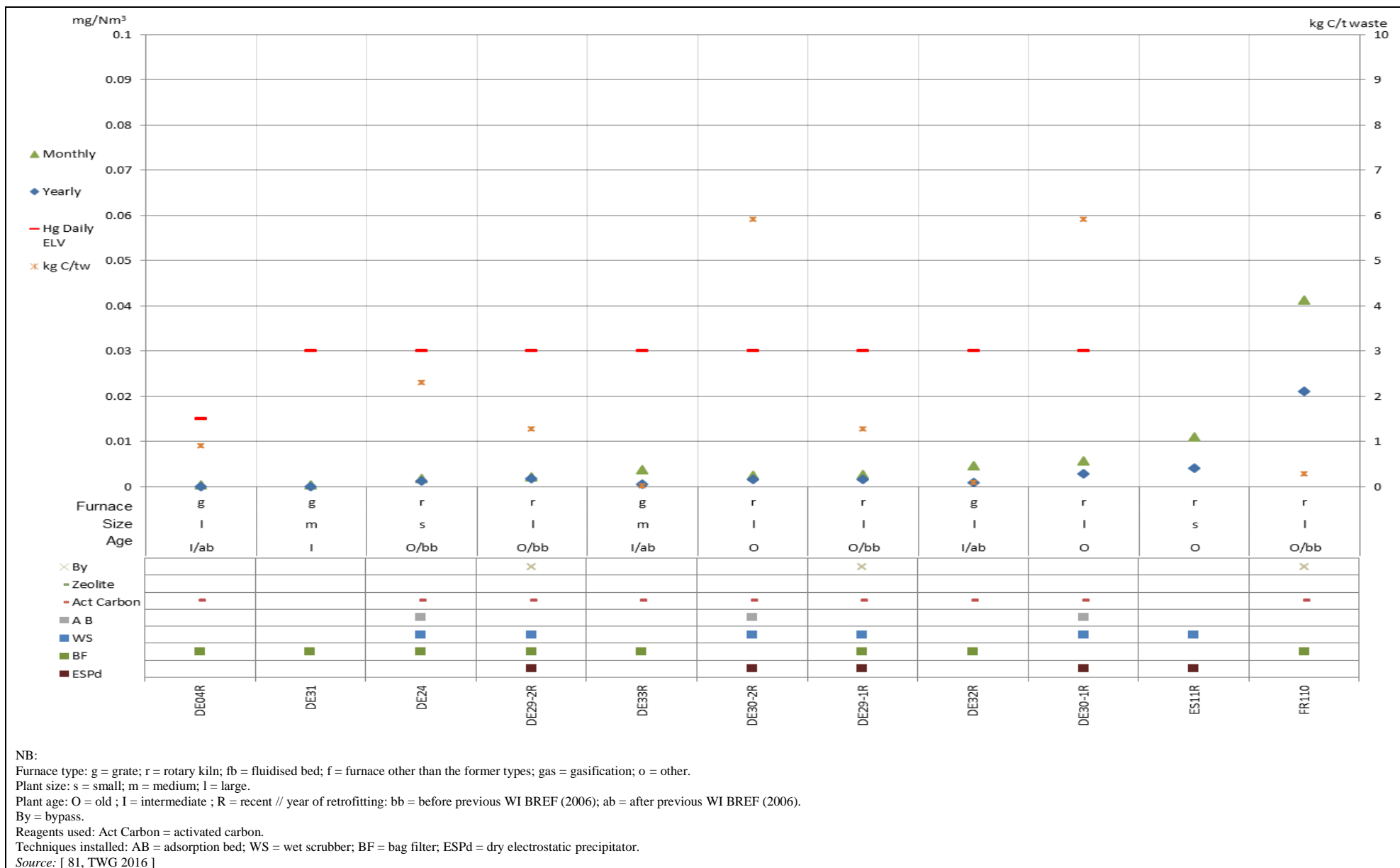

Figure 8.51: Daily and yearly average emission levels for continuously monitored Hg emissions to air from reference lines incinerating predominantly HW

8.7 Half-hourly and monthly average emission levels achieved by the waste incineration plants reporting continuously monitored emissions in the 2016 data collection: detailed graphs

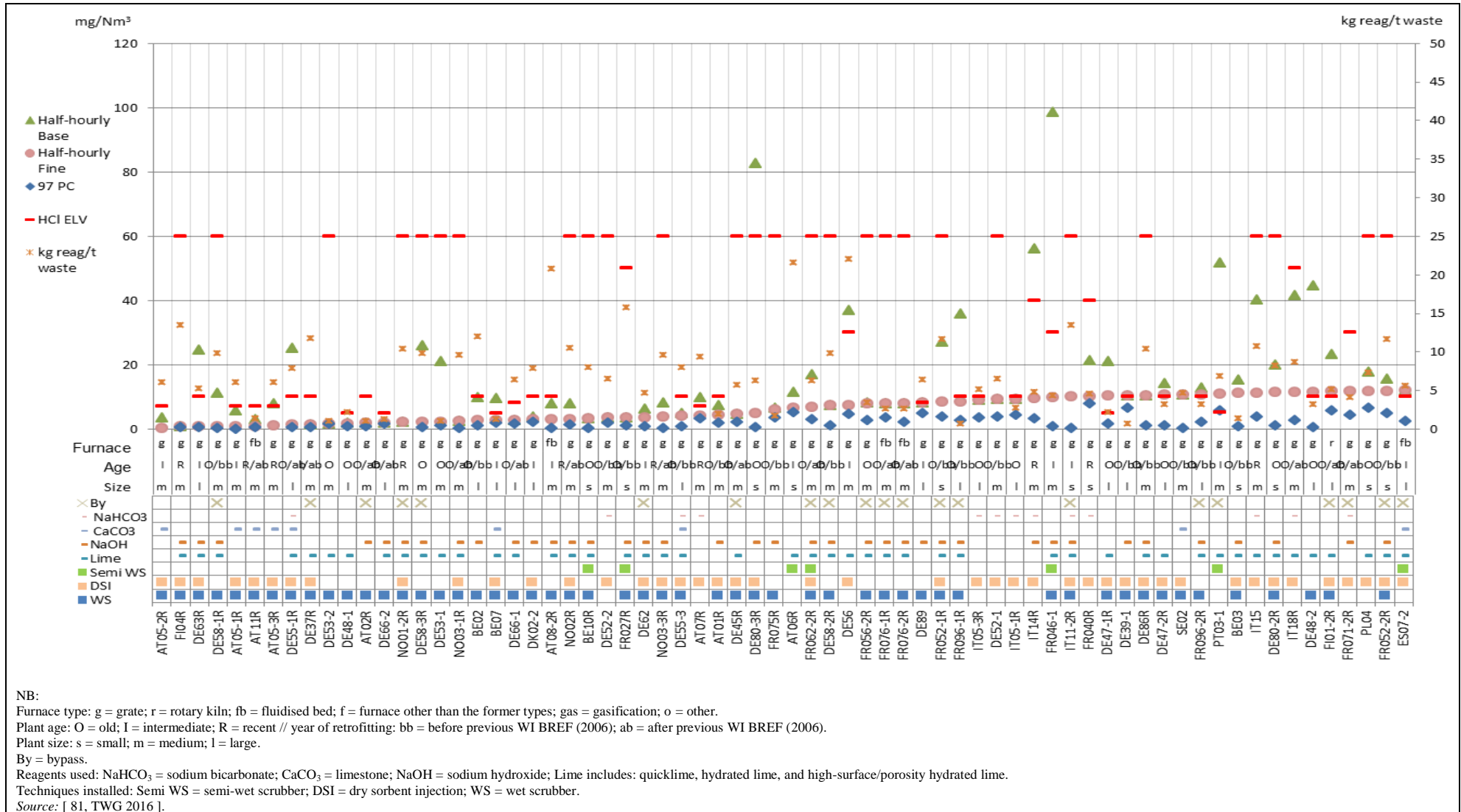

Figure 8.52: Half-hourly average emission levels for continuously monitored HCl emissions to air from reference lines incinerating predominantly MSW (1/3)

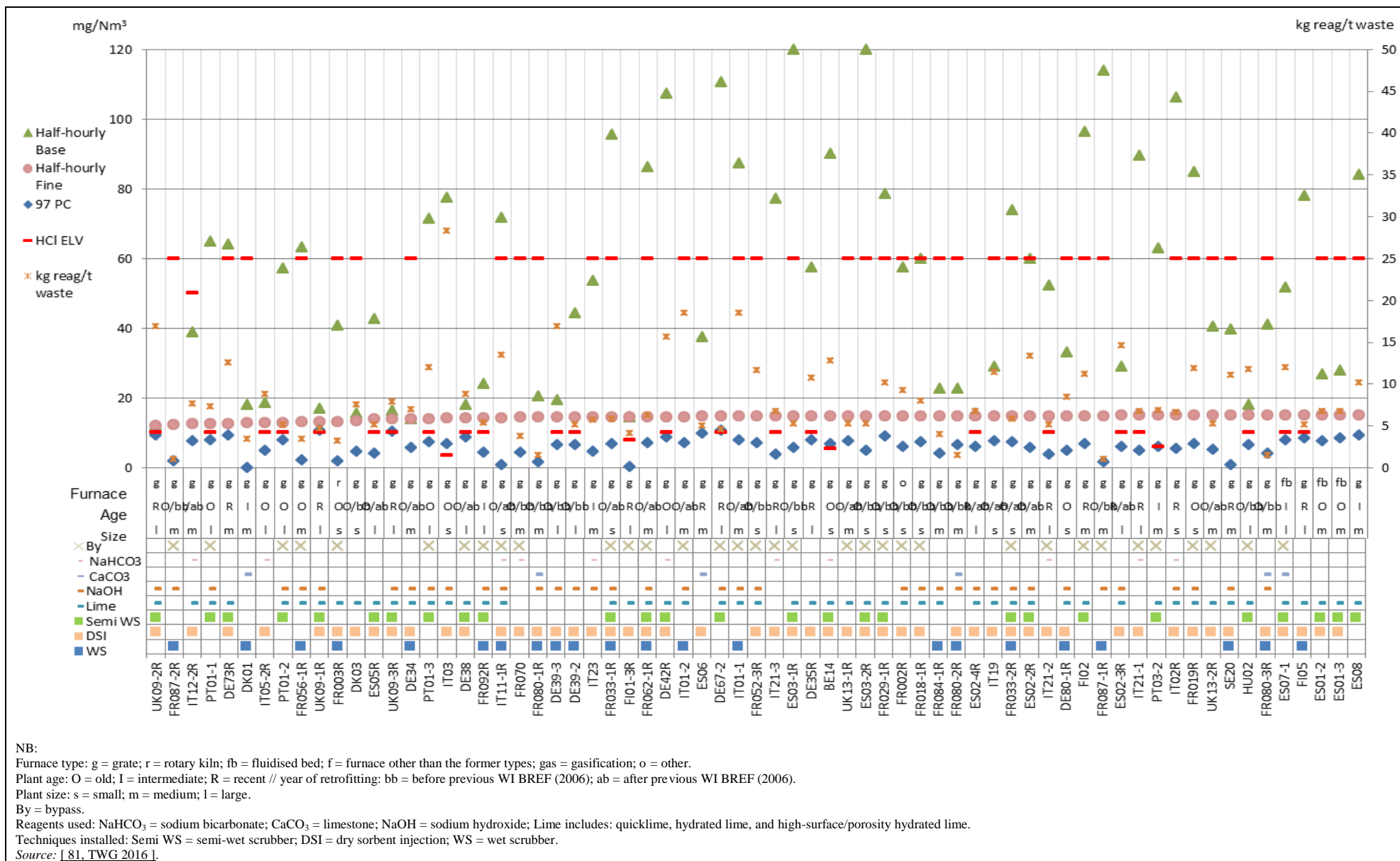

Figure 8.53: Half-hourly average emission levels for continuously monitored HCl emissions to air from reference lines incinerating predominantly MSW (2/3)

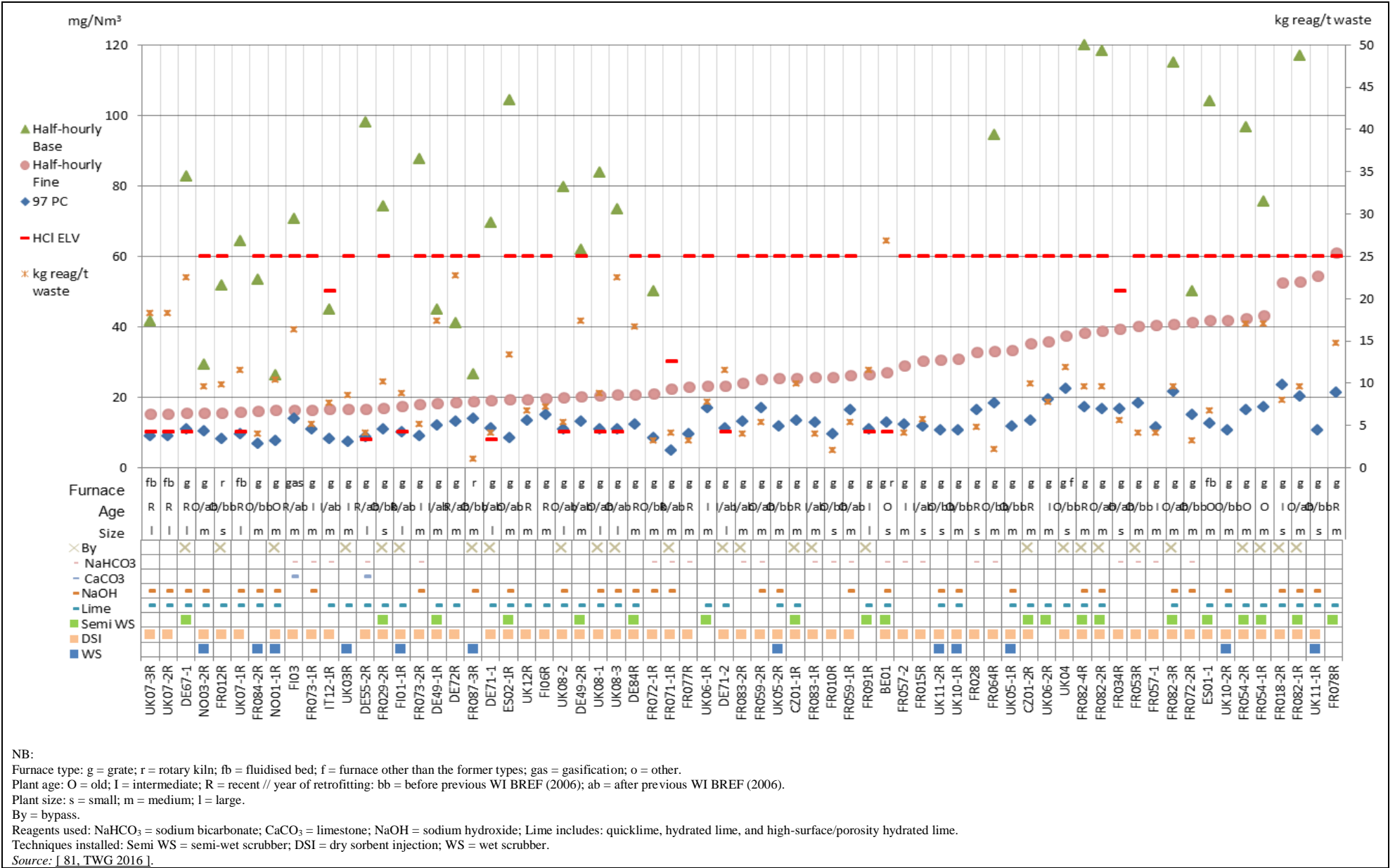

Figure 8.54: Half-hourly average emission levels for continuously monitored HCl emissions to air from reference lines incinerating predominantly MSW (3/3)

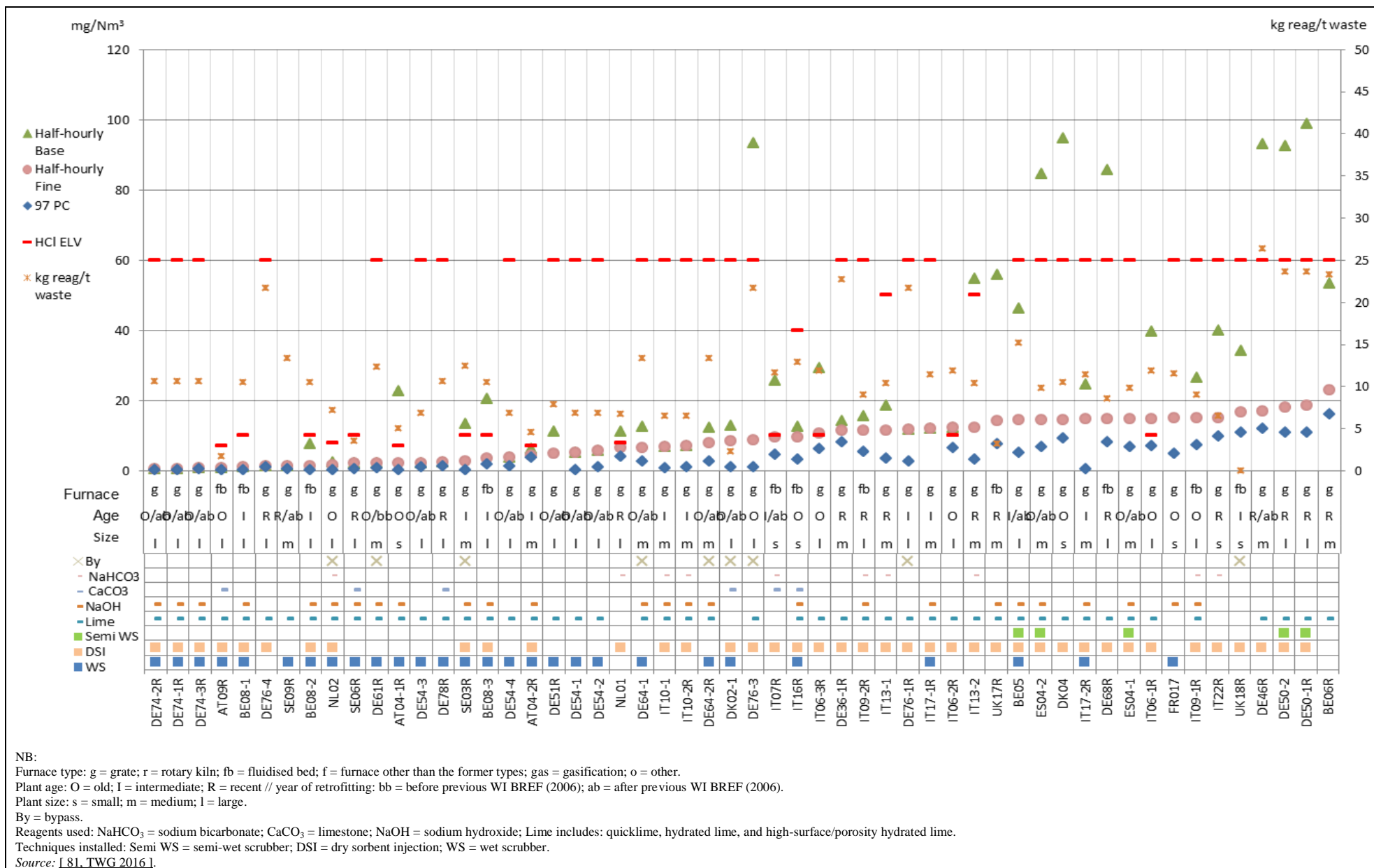

Figure 8.55: Half-hourly average emission levels for continuously monitored HCl emissions to air from reference lines incinerating predominantly ONHW

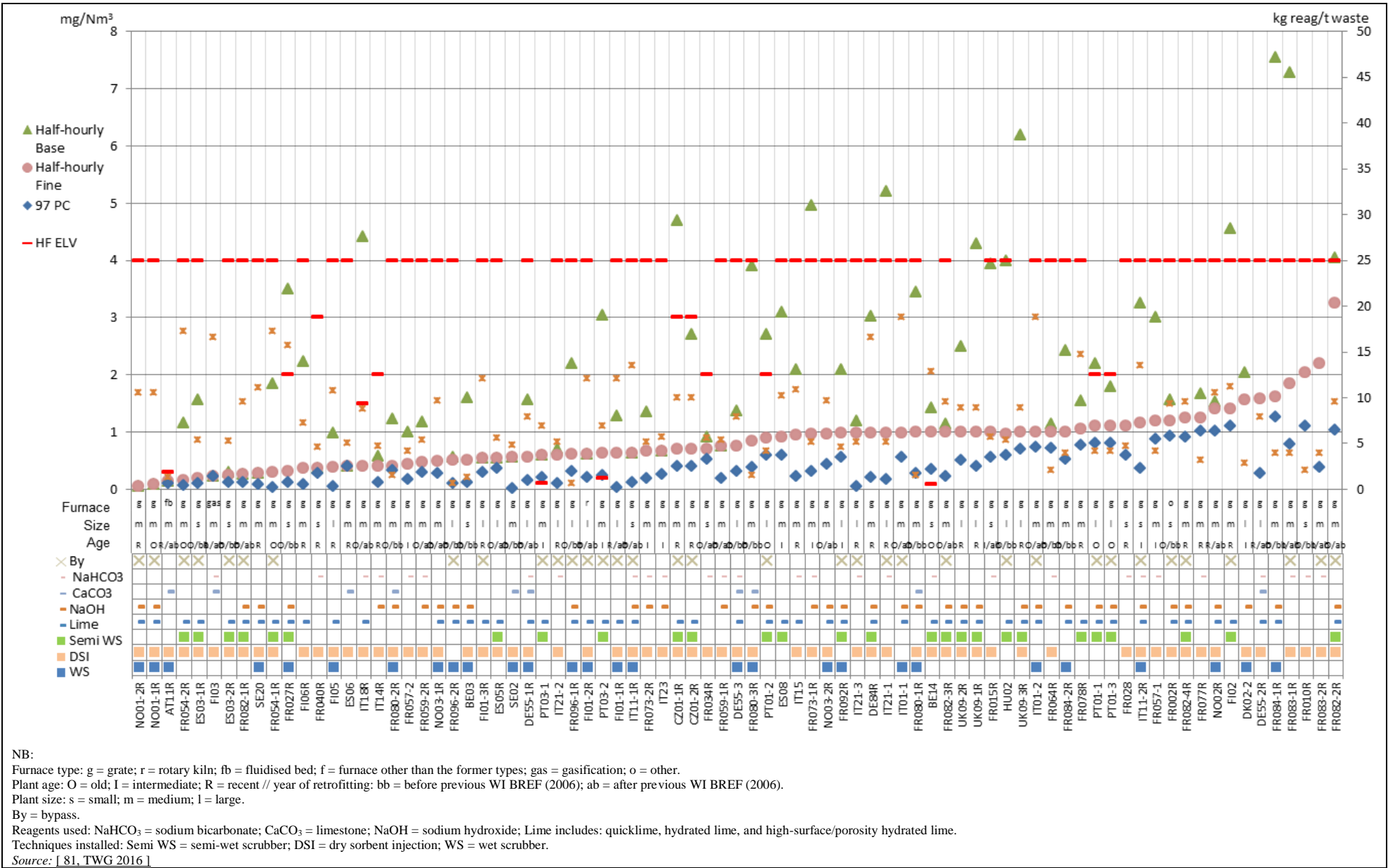

Figure 8.56: Half-hourly average emission levels for continuously monitored HF emissions to air from reference lines incinerating predominantly MSW

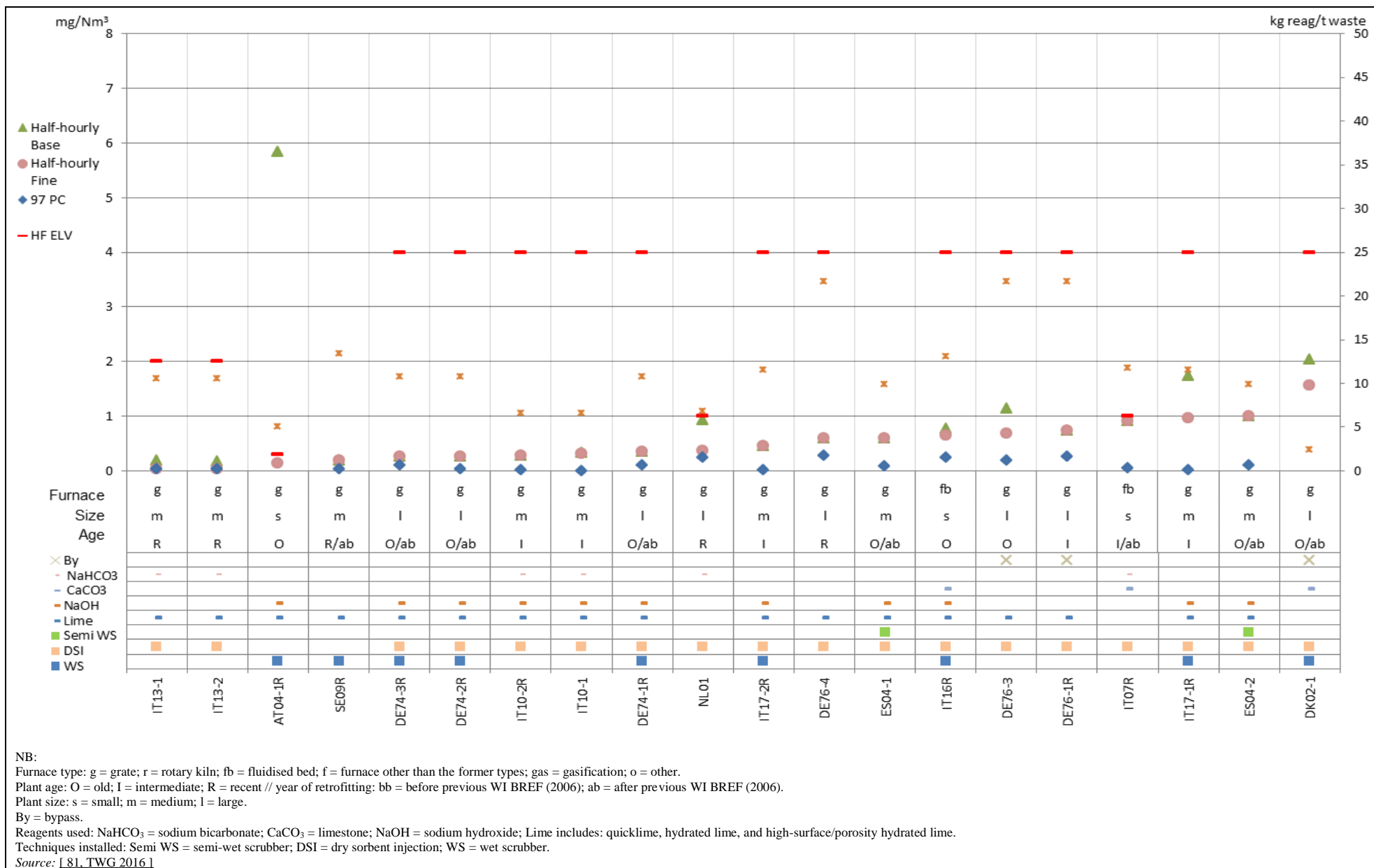

Figure 8.57: Half-hourly average emission levels for continuously monitored HF emissions to air from reference lines incinerating predominantly ONHW

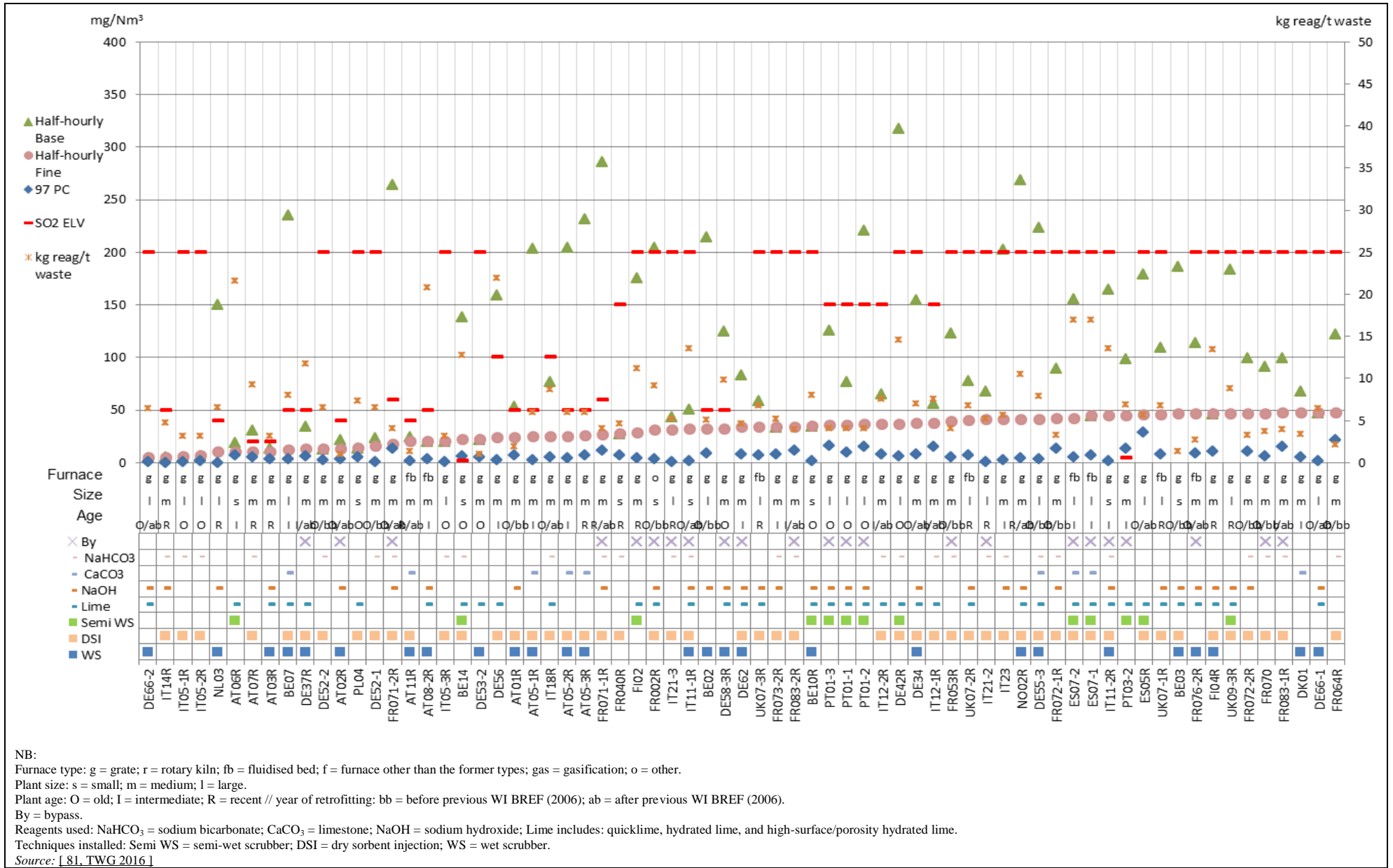

Figure 8.58: Half-hourly average emission levels for continuously monitored SO₂ emissions to air from reference lines incinerating predominantly MSW (1/3)

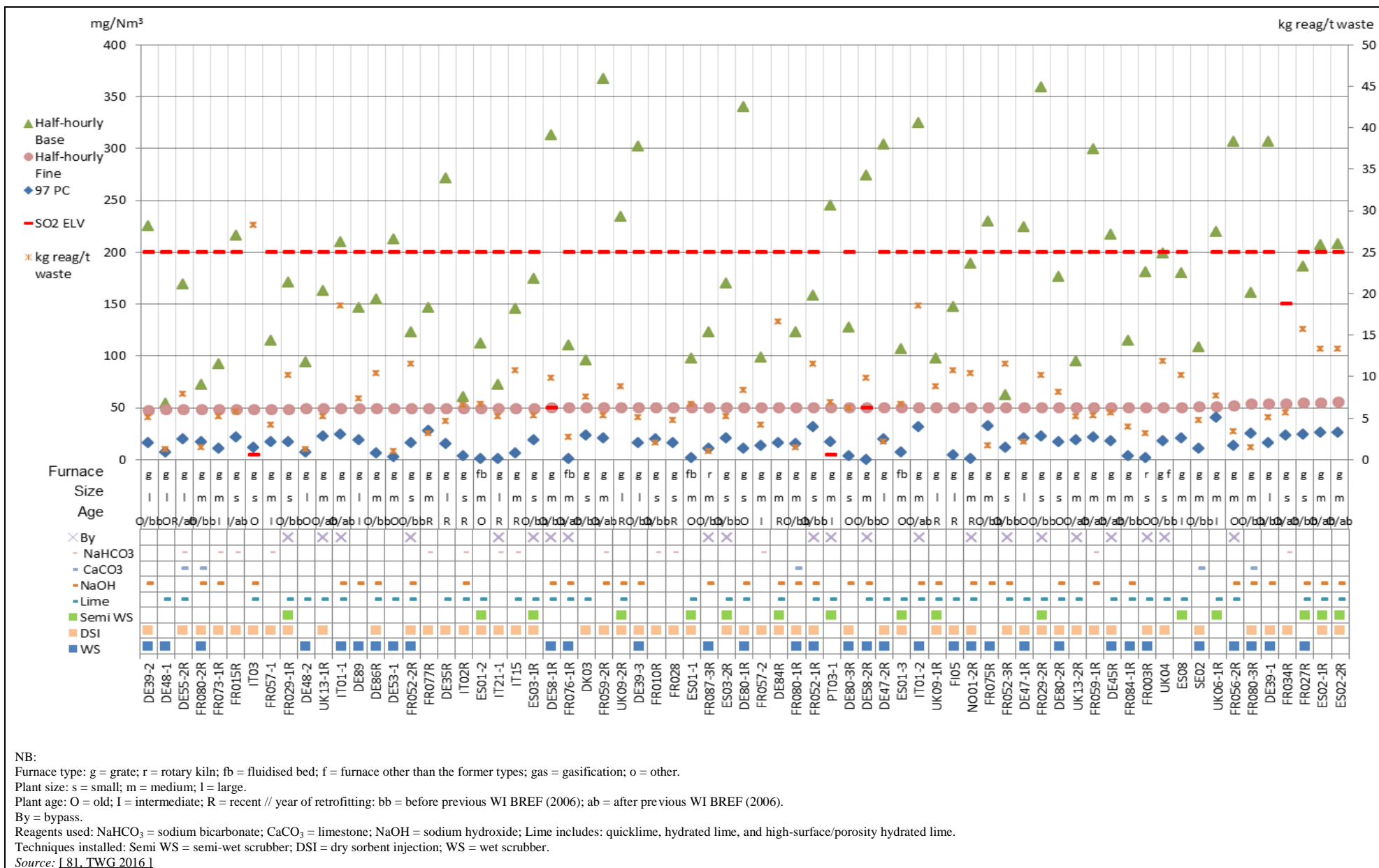

Figure 8.59: Half-hourly average emission levels for continuously monitored SO₂ emissions to air from reference lines incinerating predominantly MSW (2/3)

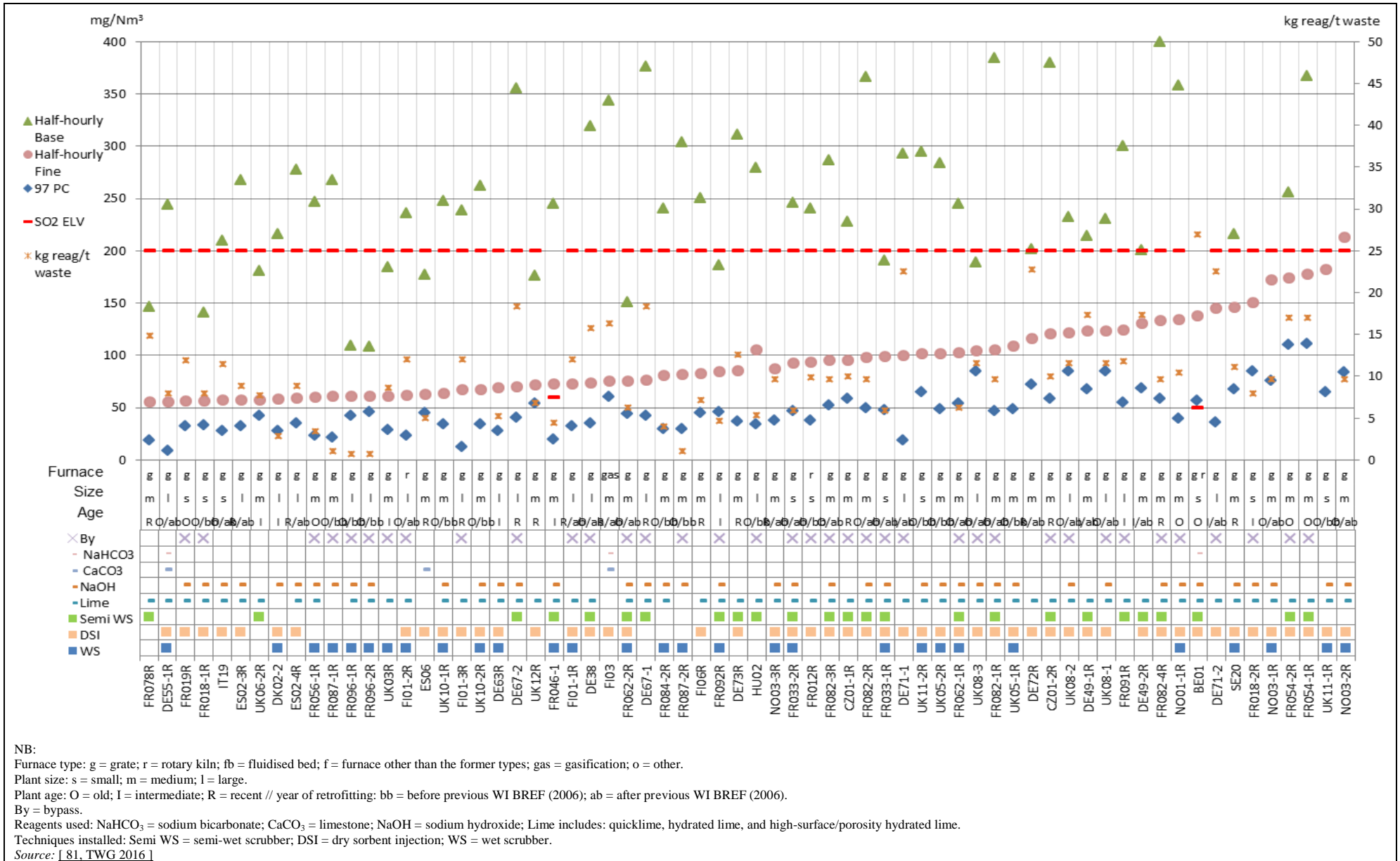

Figure 8.60: Half-hourly average emission levels for continuously monitored SO₂ emissions to air from reference lines incinerating predominantly MSW (3/3)

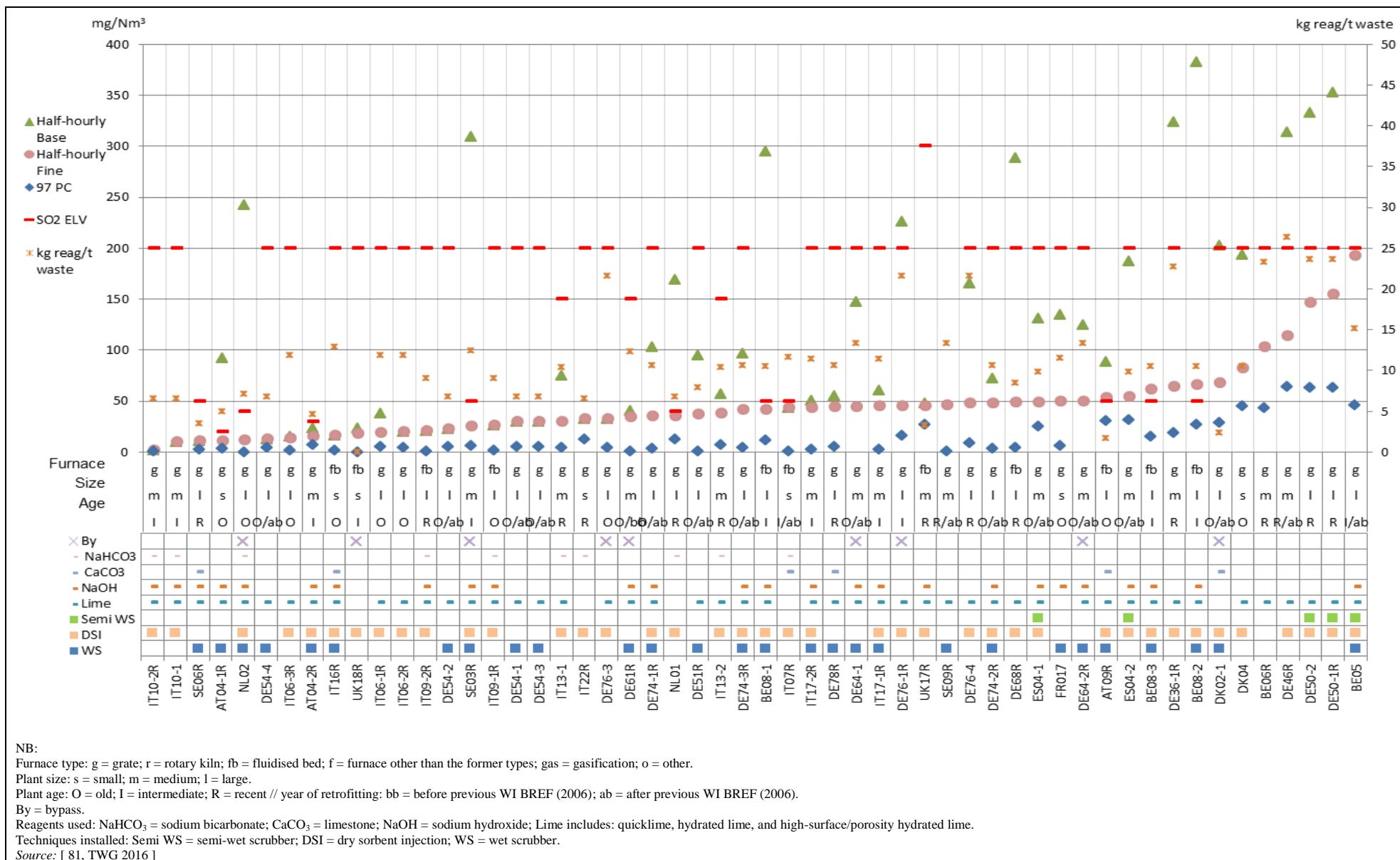

Figure 8.61: Half-hourly average emission levels for continuously monitored SO₂ emissions to air from reference lines incinerating predominantly ONHW

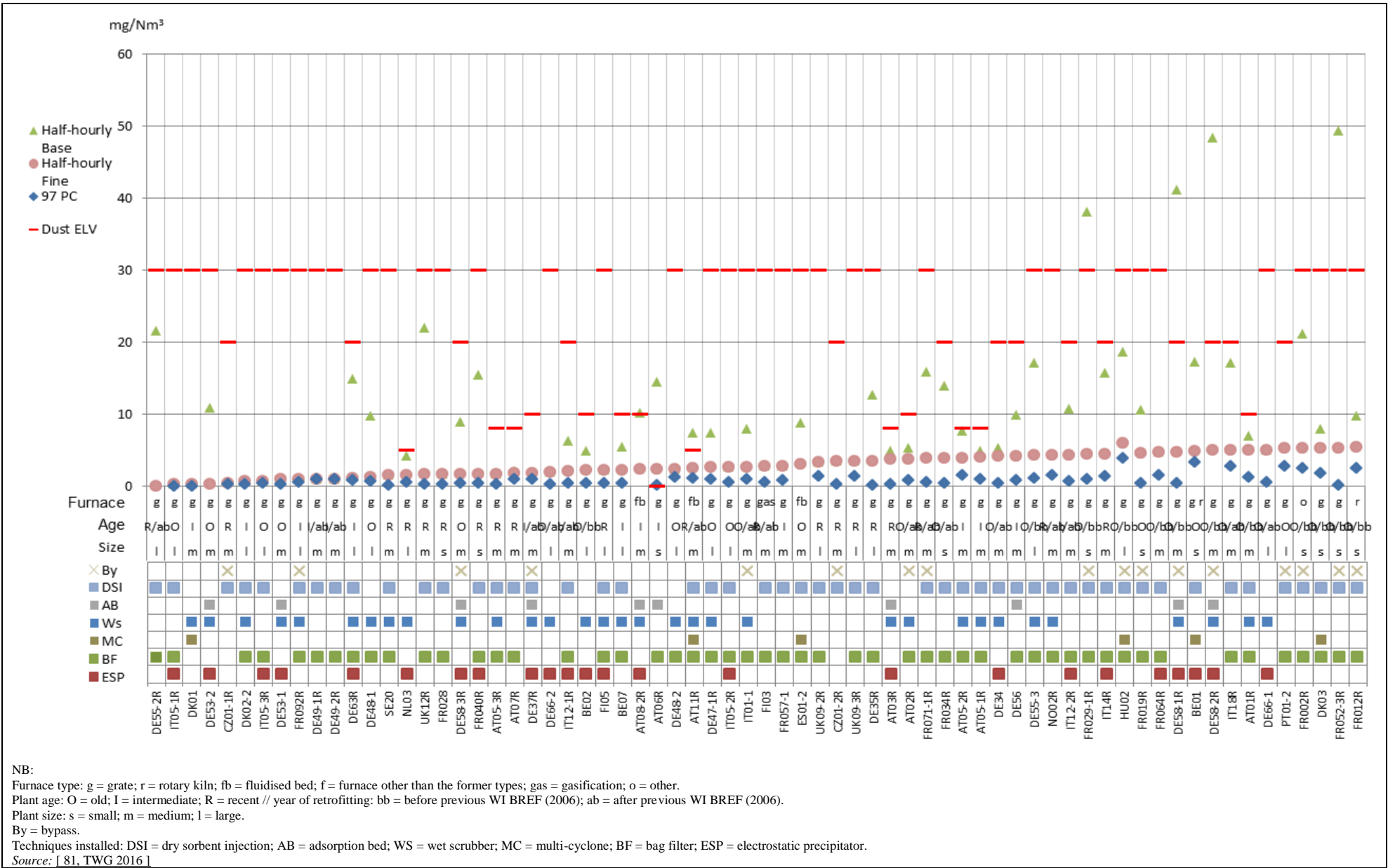

Figure 8.62: Half-hourly average emission levels for continuously monitored dust emissions to air from reference lines incinerating predominantly MSW (1/3)

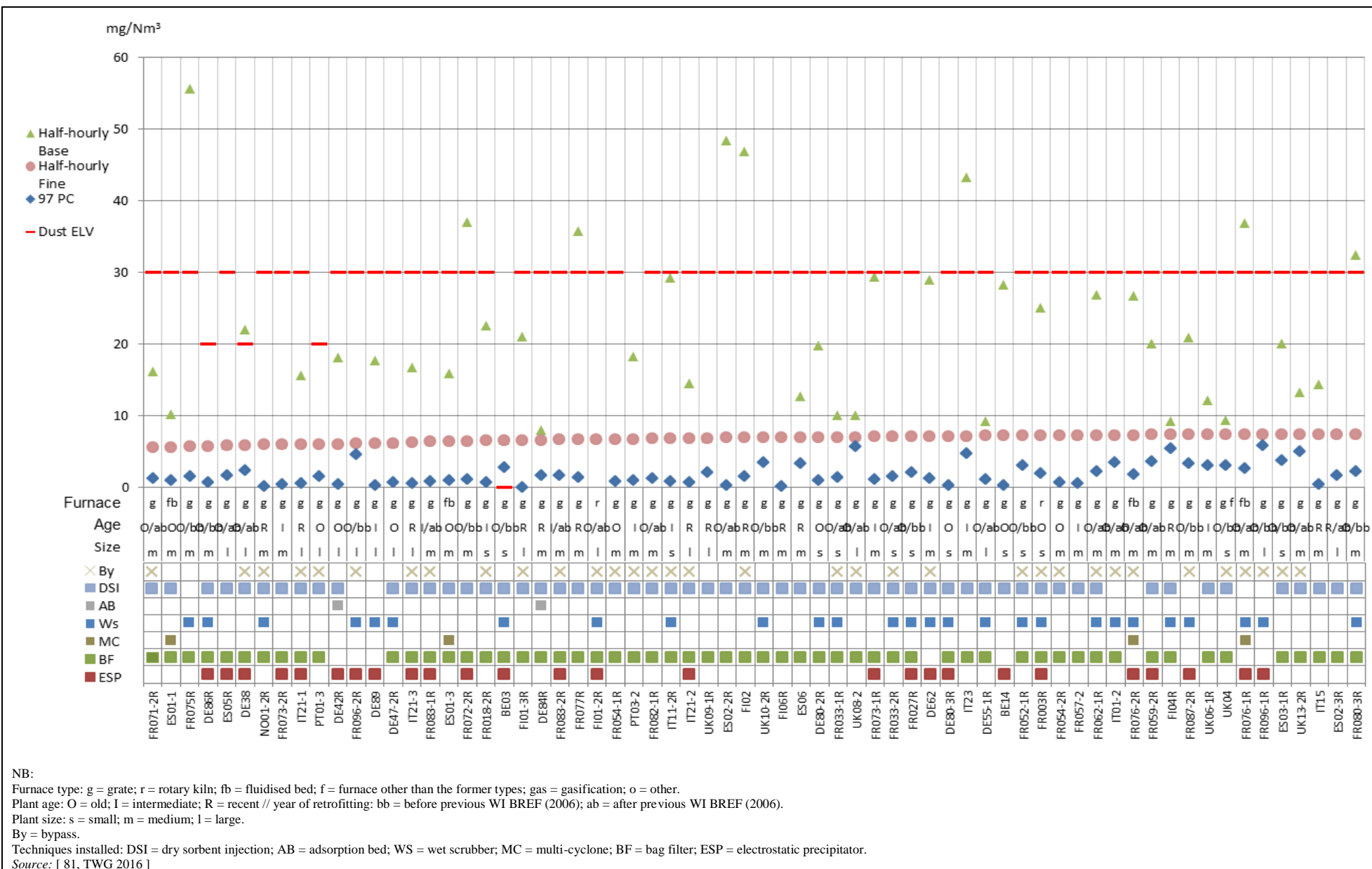

Figure 8.63: Half-hourly average emission levels for continuously monitored dust emissions to air from reference lines incinerating predominantly MSW (2/3)

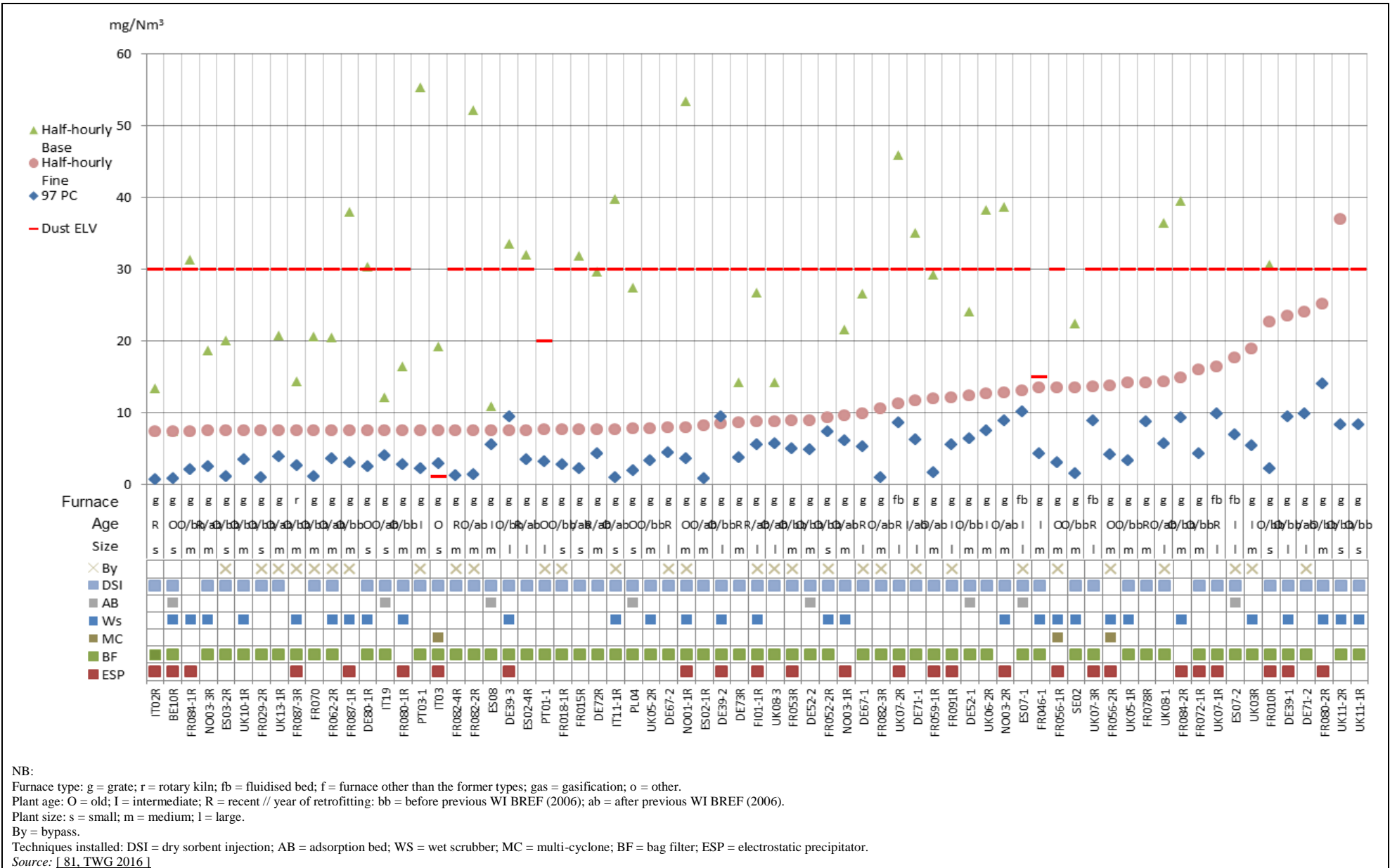

Figure 8.64: Half-hourly average emission levels for continuously monitored dust emissions to air from reference lines incinerating predominantly MSW (3/3)

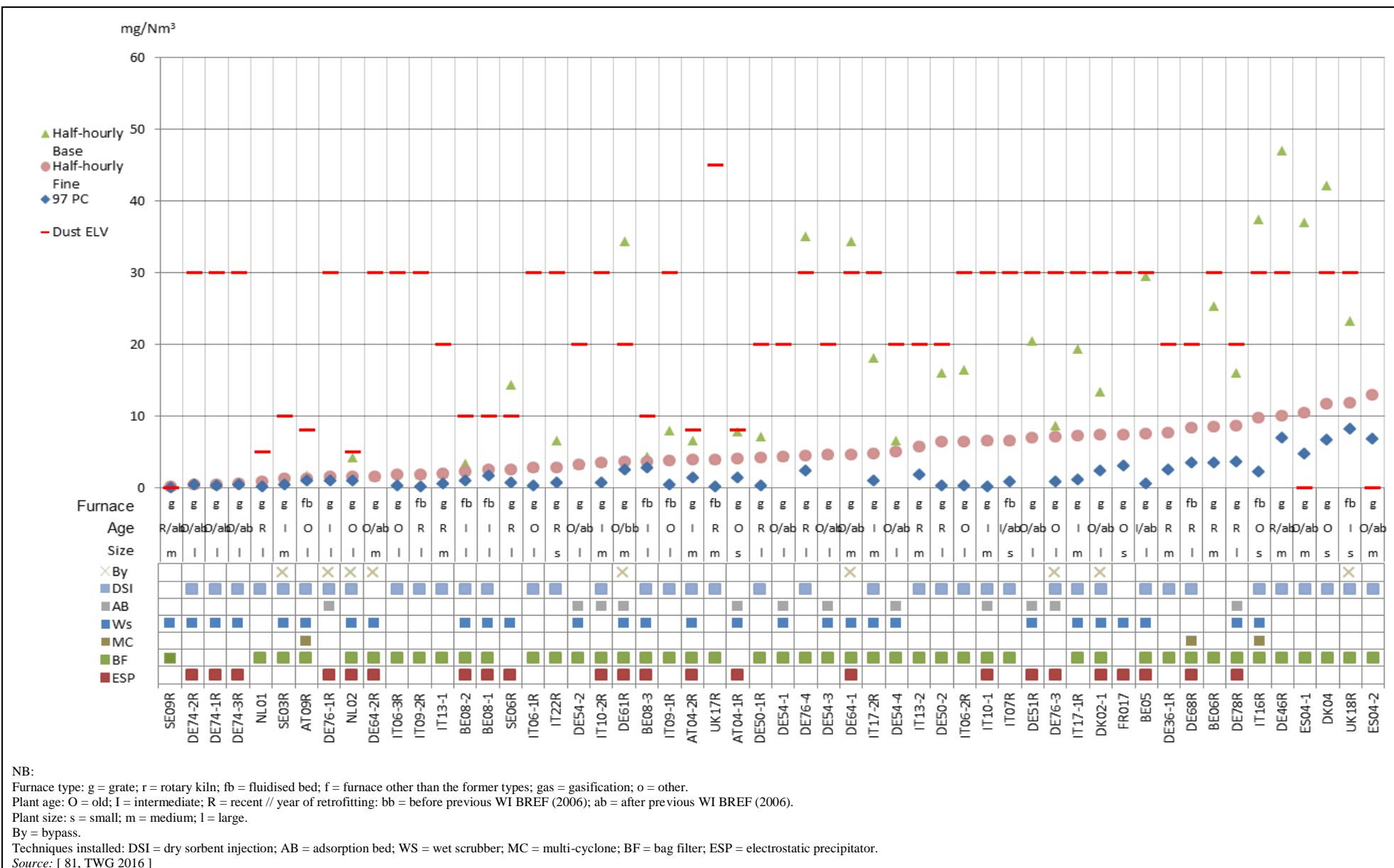

Figure 8.65: Half-hourly average emission levels for continuously monitored dust emissions to air from reference lines incinerating predominantly ONHW

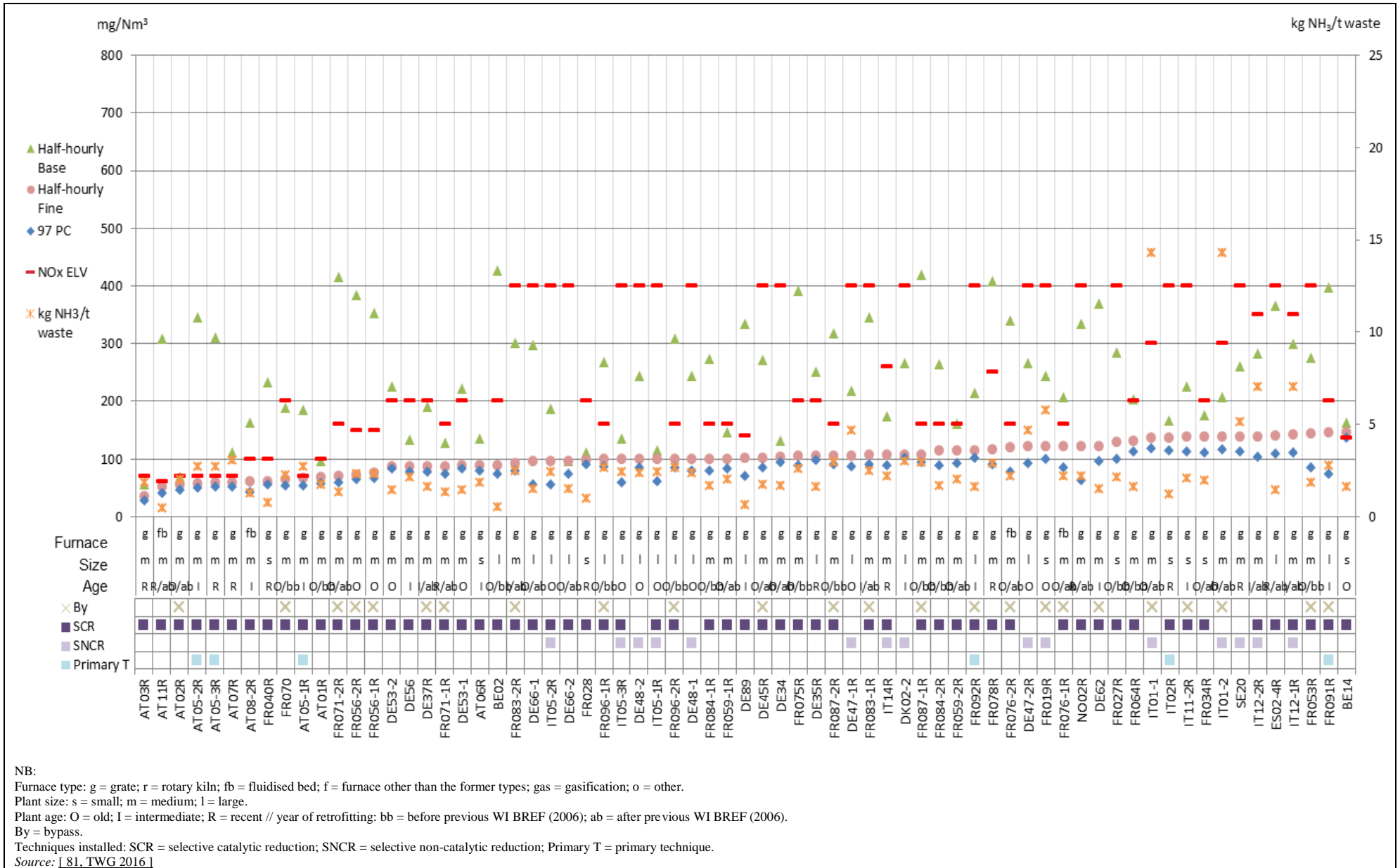

Figure 8.66: Half-hourly average emission levels for continuously monitored NO_x emissions to air from reference lines incinerating predominantly MSW (1/3)

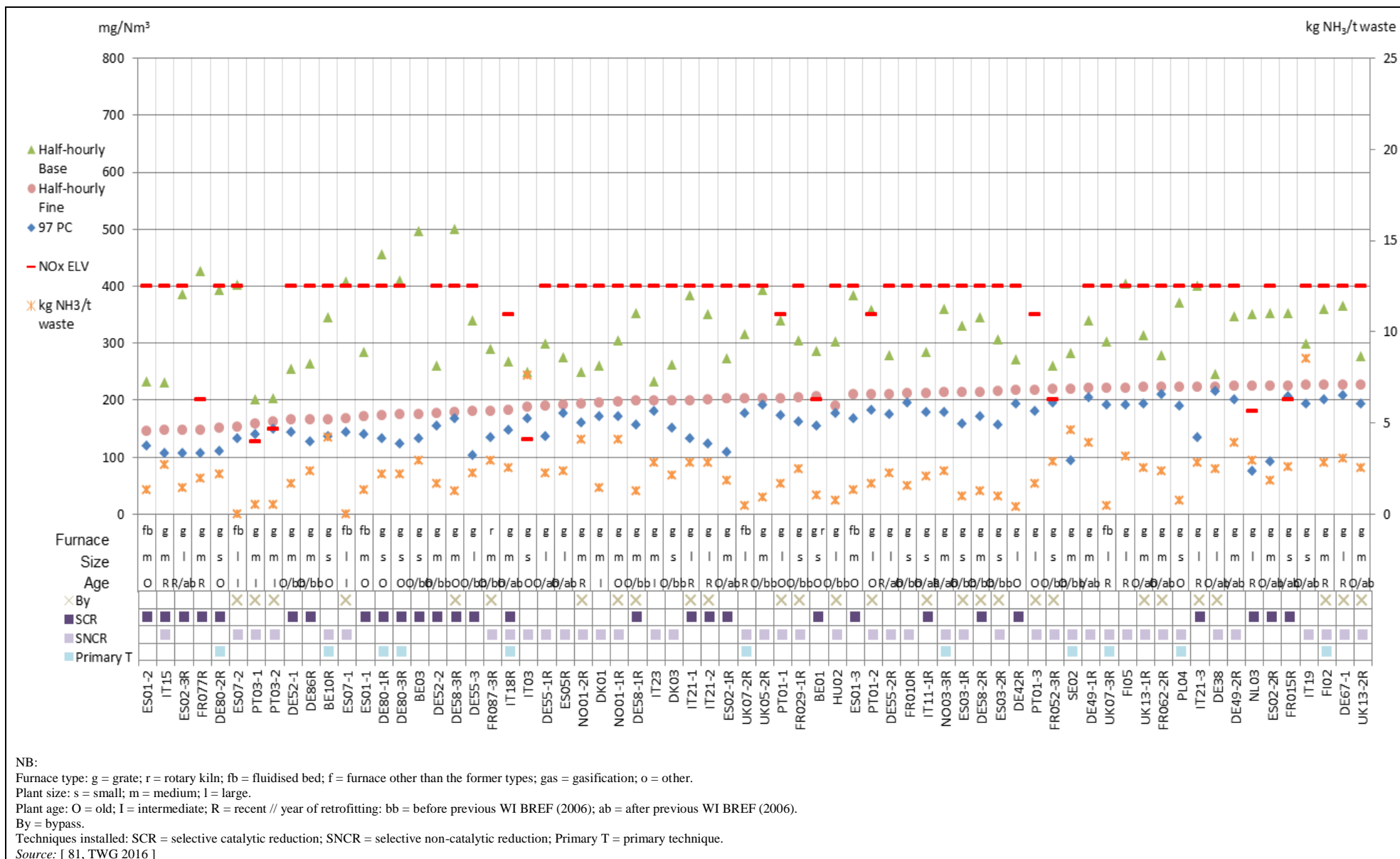

Figure 8.67: Half-hourly average emission levels for continuously monitored NO_x emissions to air from reference lines incinerating predominantly MSW (2/3)

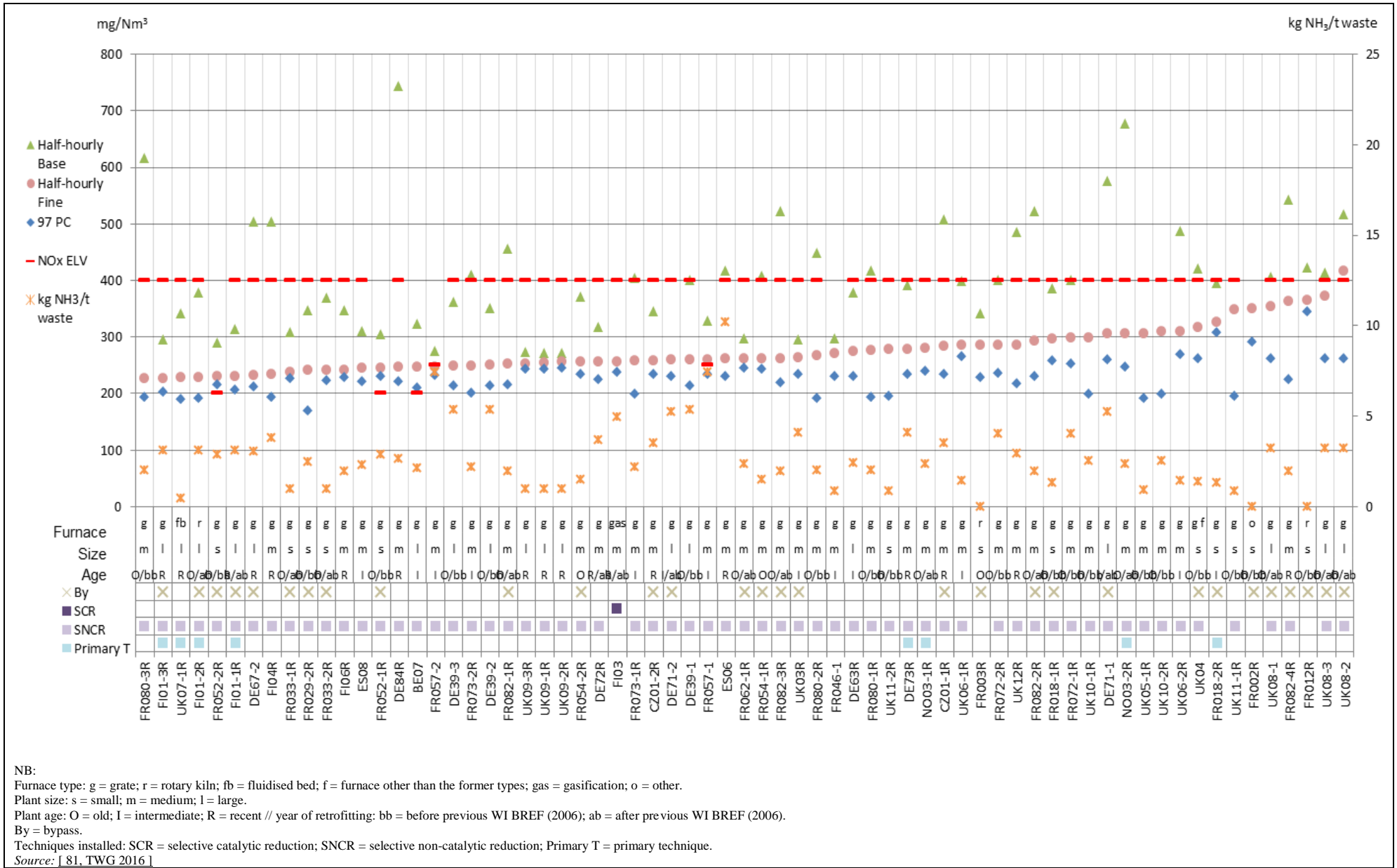

Figure 8.68: Half-hourly average emission levels for continuously monitored NO_x emissions to air from reference lines incinerating predominantly MSW (3/3)

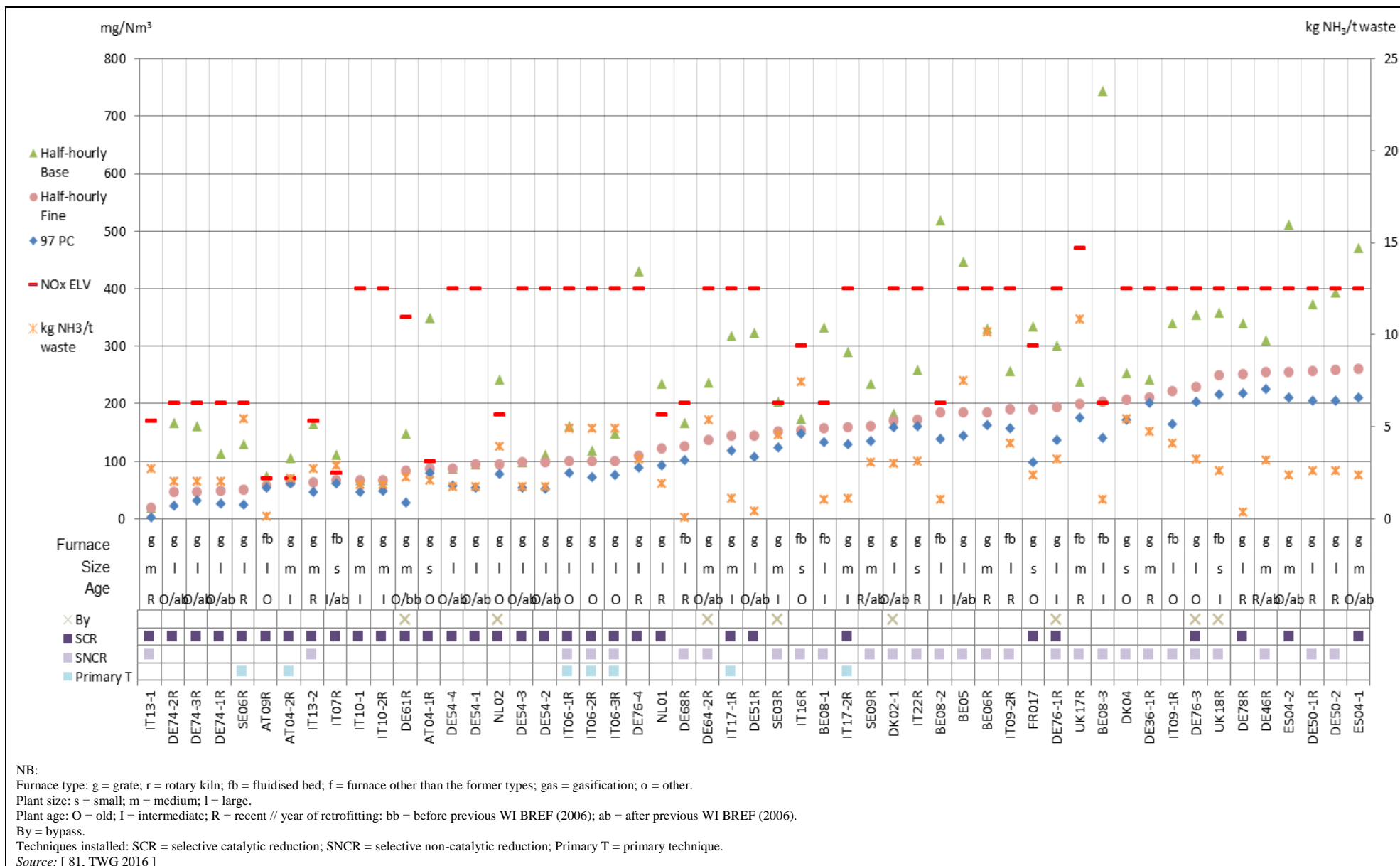

Figure 8.69: Half-hourly average emission levels for continuously monitored NO_x emissions to air from reference lines incinerating predominantly ONHW

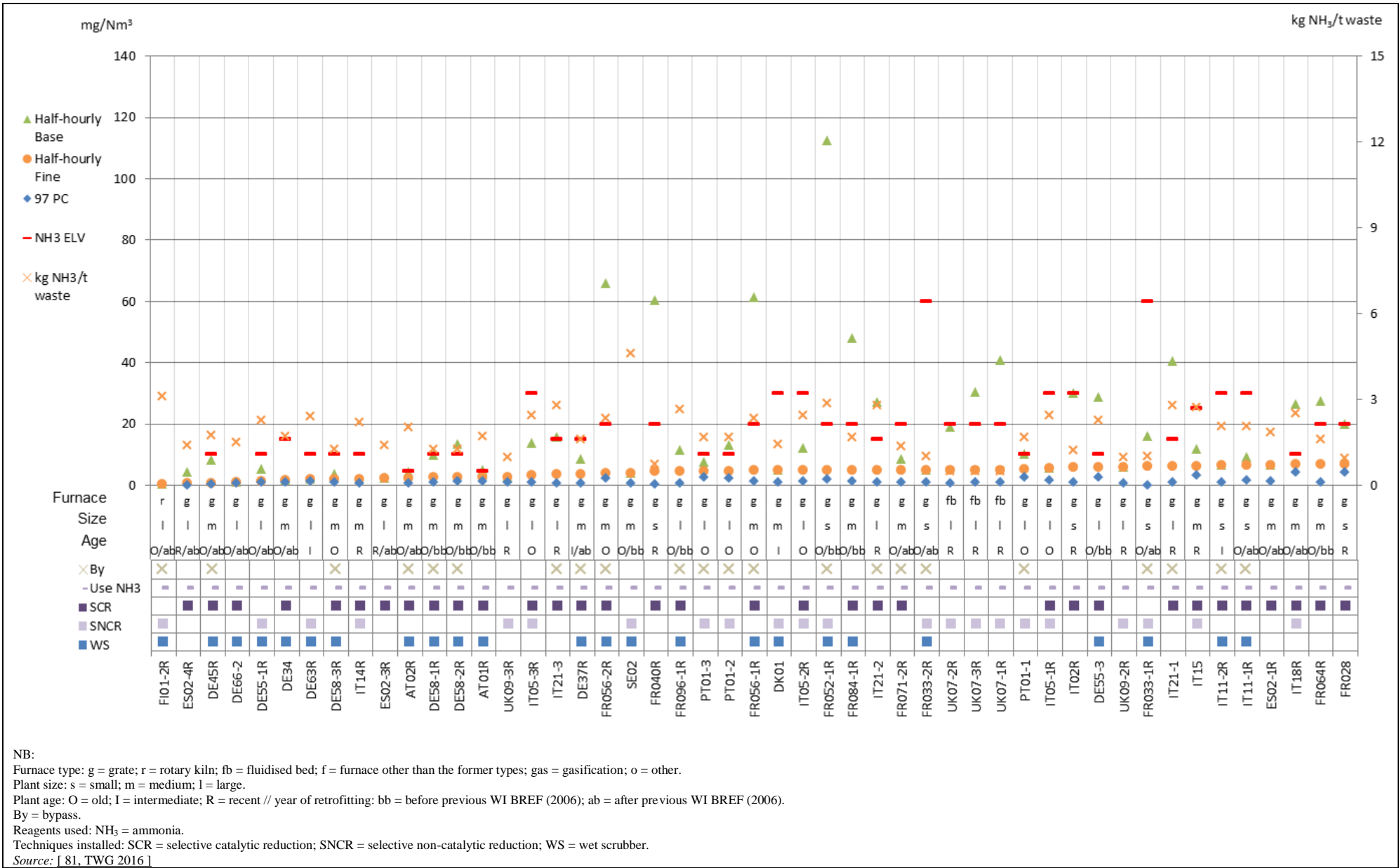

Figure 8.70: Half-hourly average emission levels for continuously monitored NH₃ emissions to air from reference lines incinerating predominantly MSW (1/3)

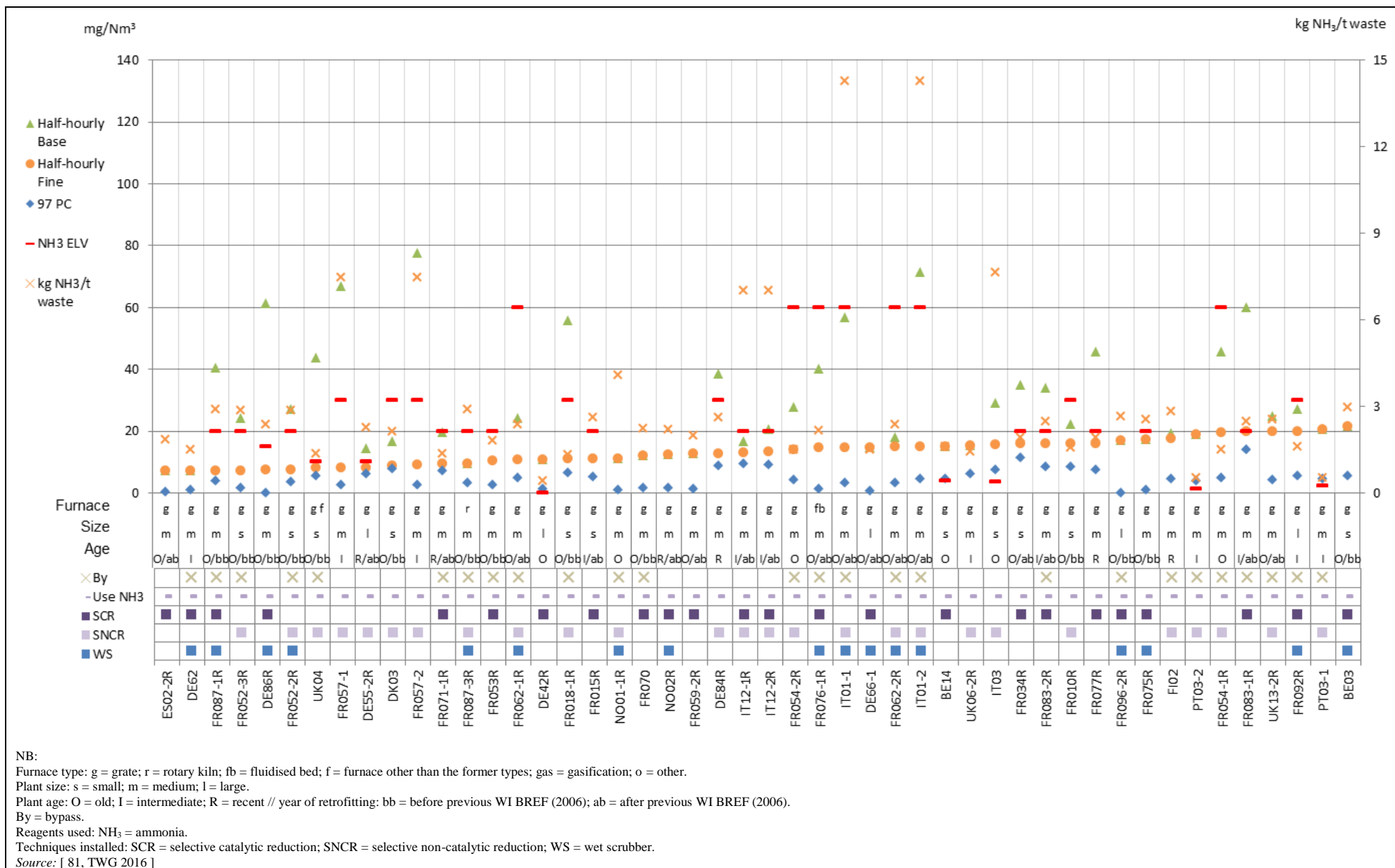

Figure 8.71: Half-hourly average emission levels for continuously monitored NH₃ emissions to air from reference lines incinerating predominantly MSW (2/3)

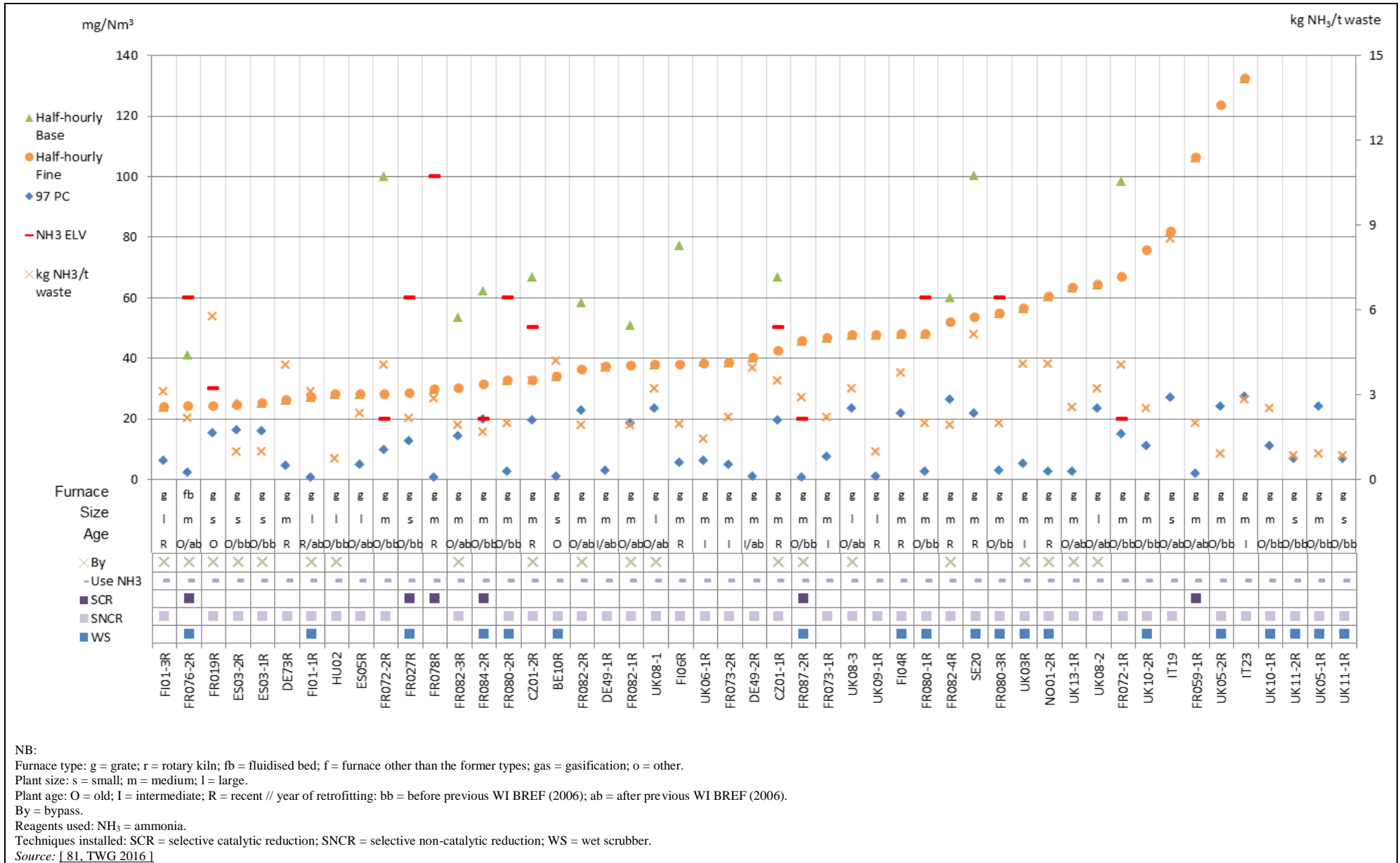

Figure 8.72: Half-hourly average emission levels for continuously monitored NH₃ emissions to air from reference lines incinerating predominantly MSW (3/3)

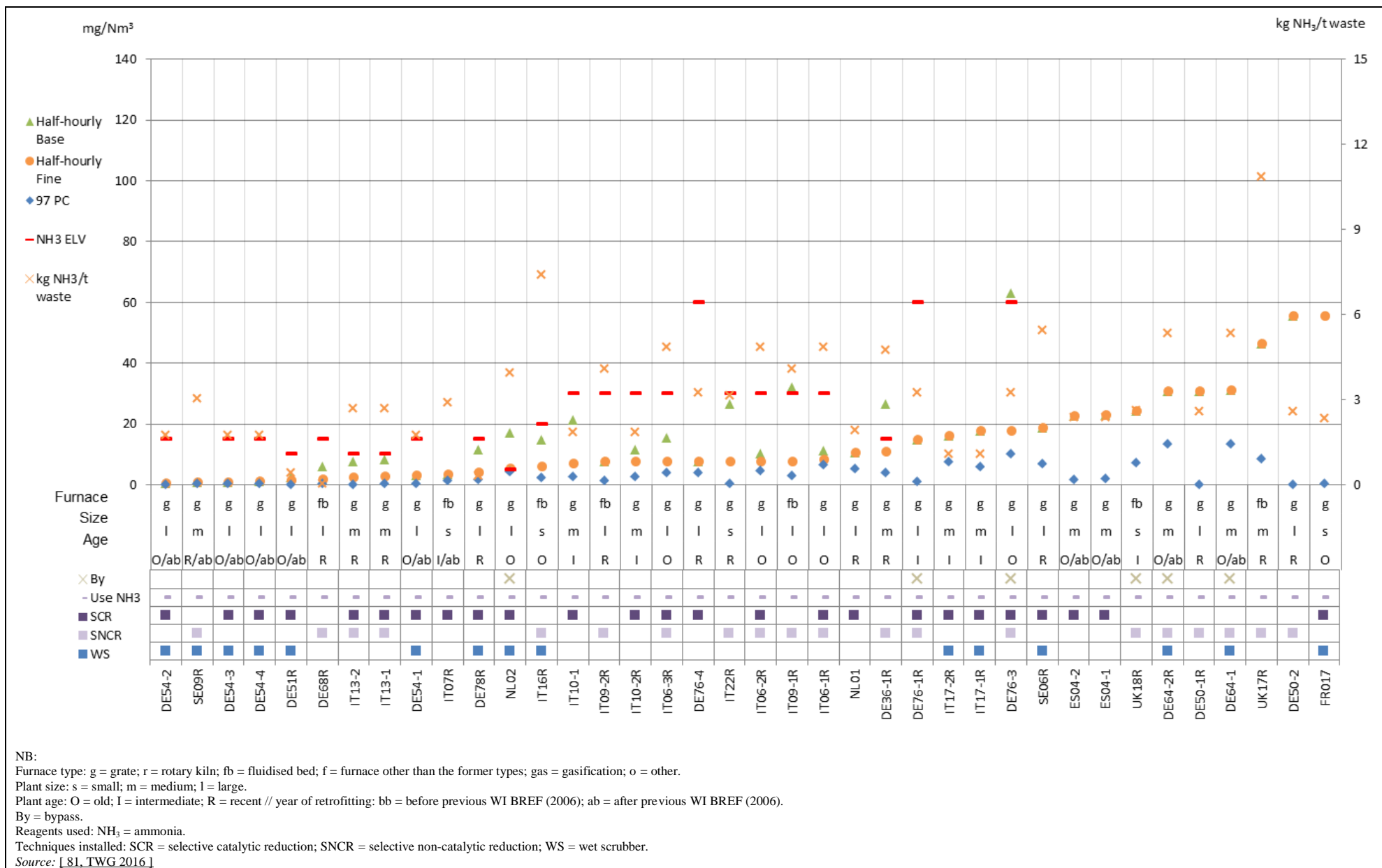

Figure 8.73: Half-hourly average emission levels for continuously monitored NH₃ emissions to air from reference lines incinerating predominantly ONHW

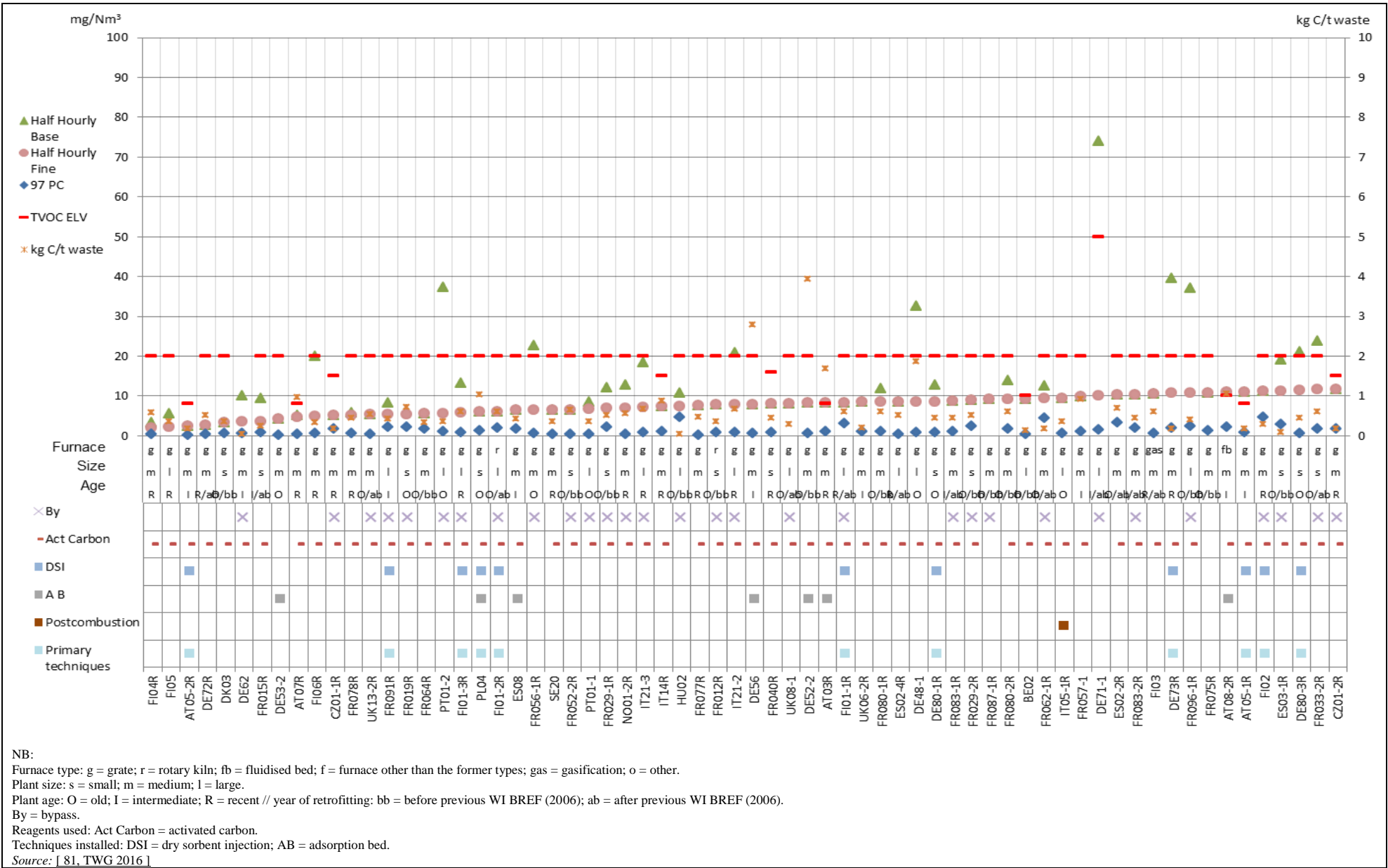

Figure 8.74: Half-hourly average emission levels for continuously monitored TVOC emissions to air from reference lines incinerating predominantly MSW (1/3)

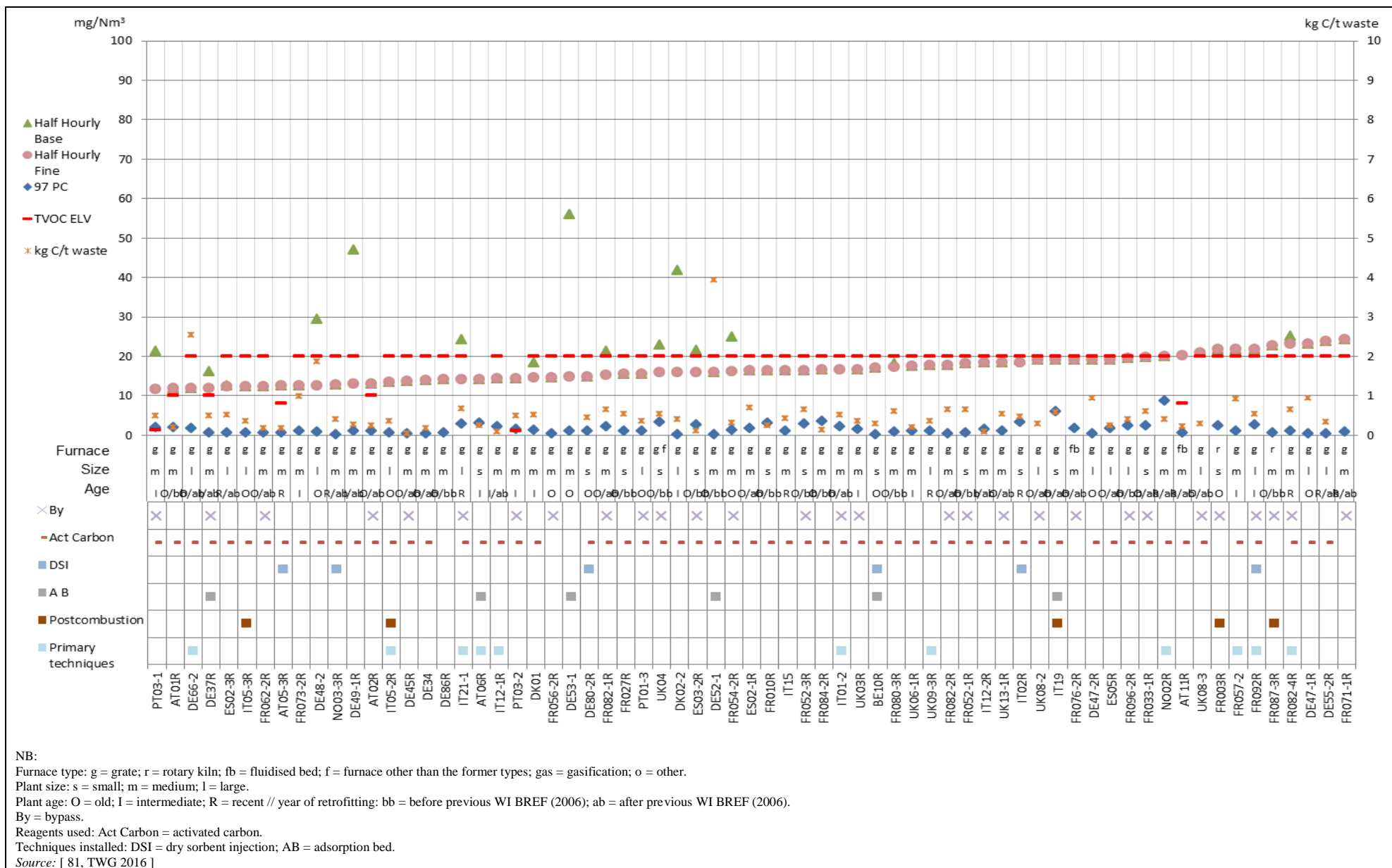

Figure 8.75: Half-hourly average emission levels for continuously monitored TVOC emissions to air from reference lines incinerating predominantly MSW (2/3)

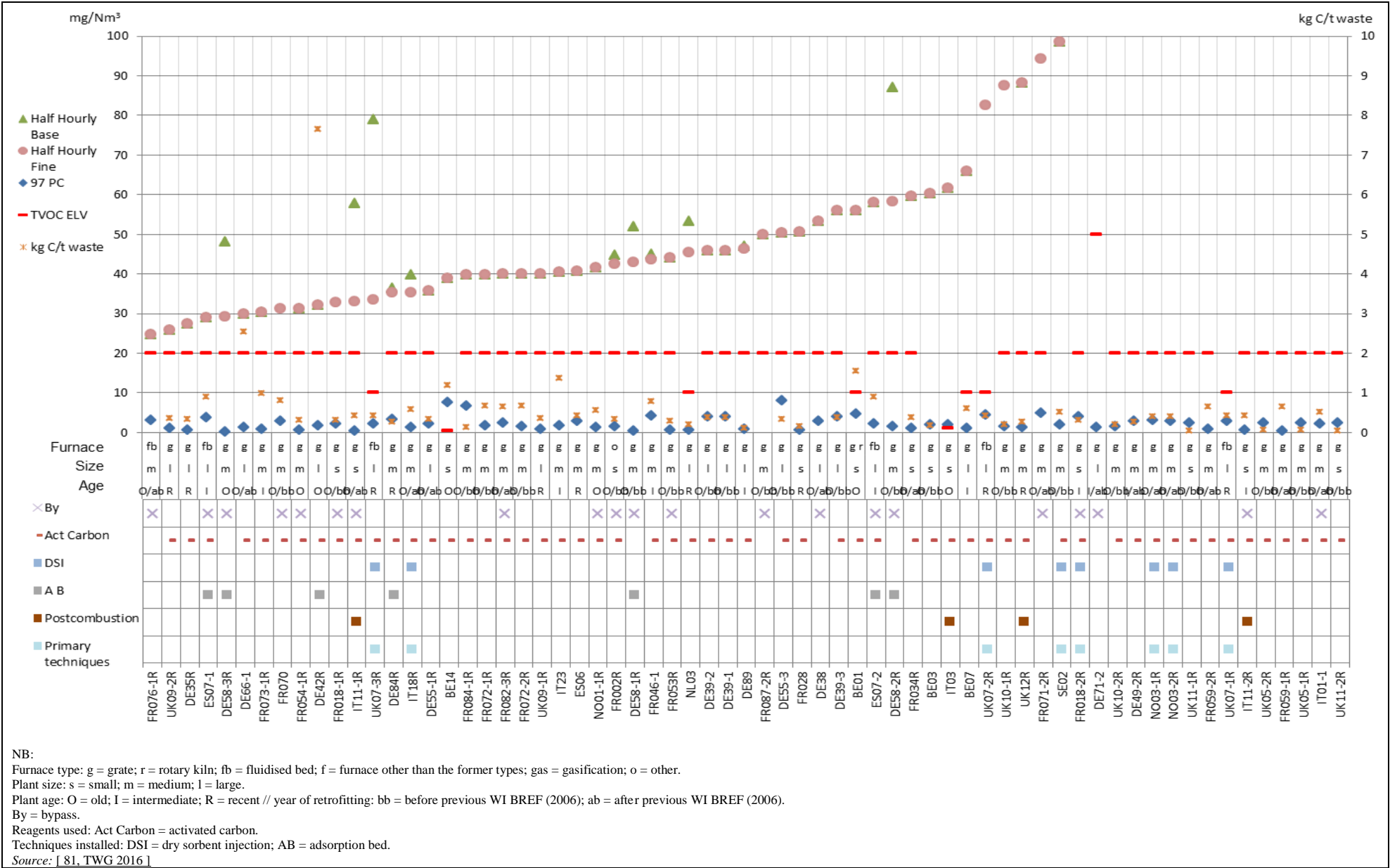

Figure 8.76: Half-hourly average emission levels for continuously monitored TVOC emissions to air from reference lines incinerating predominantly MSW (3/3)

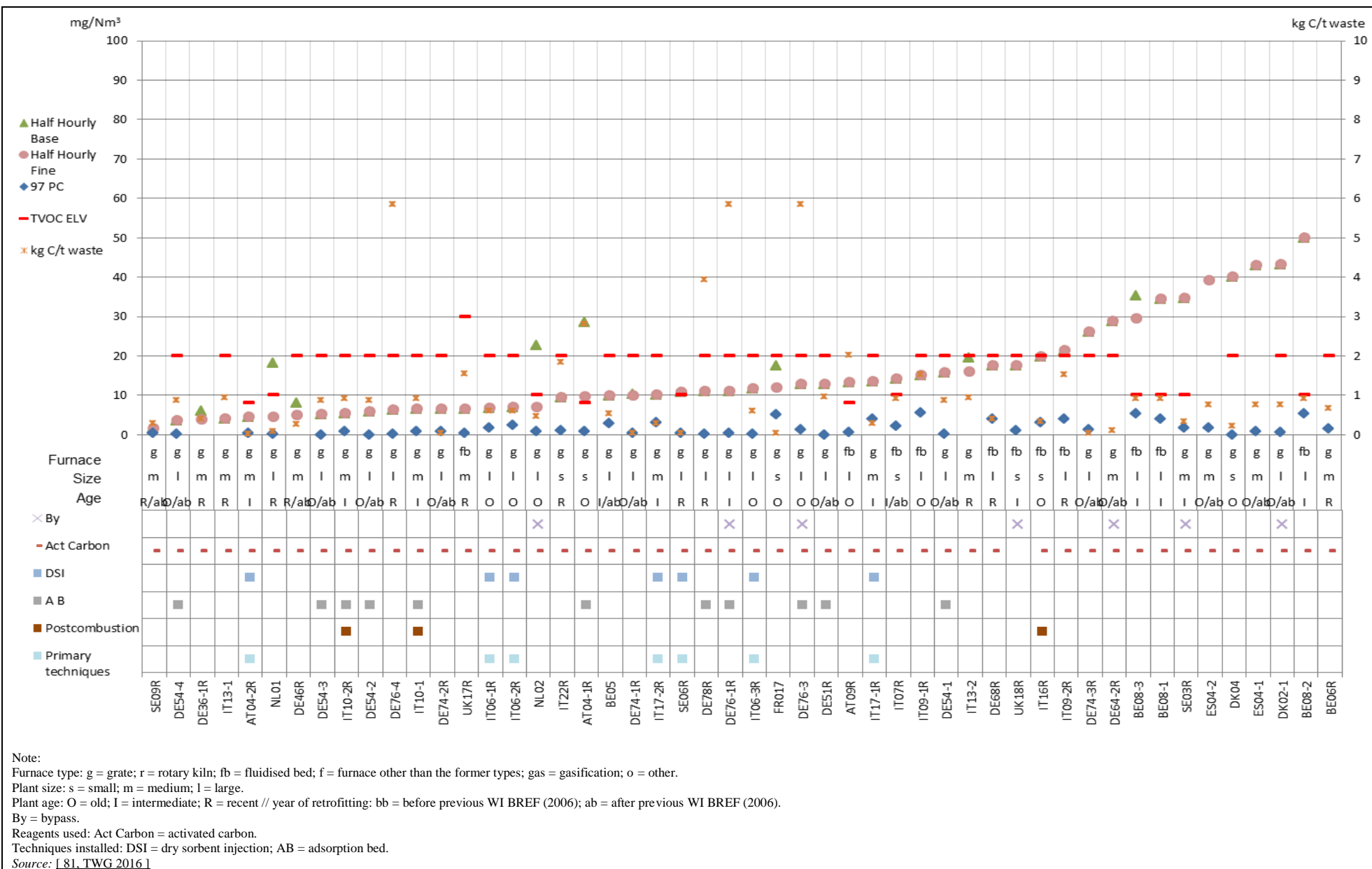

Figure 8.77: Half-hourly average emission levels for continuously monitored TVOC emissions to air from reference lines incinerating predominantly ONHW

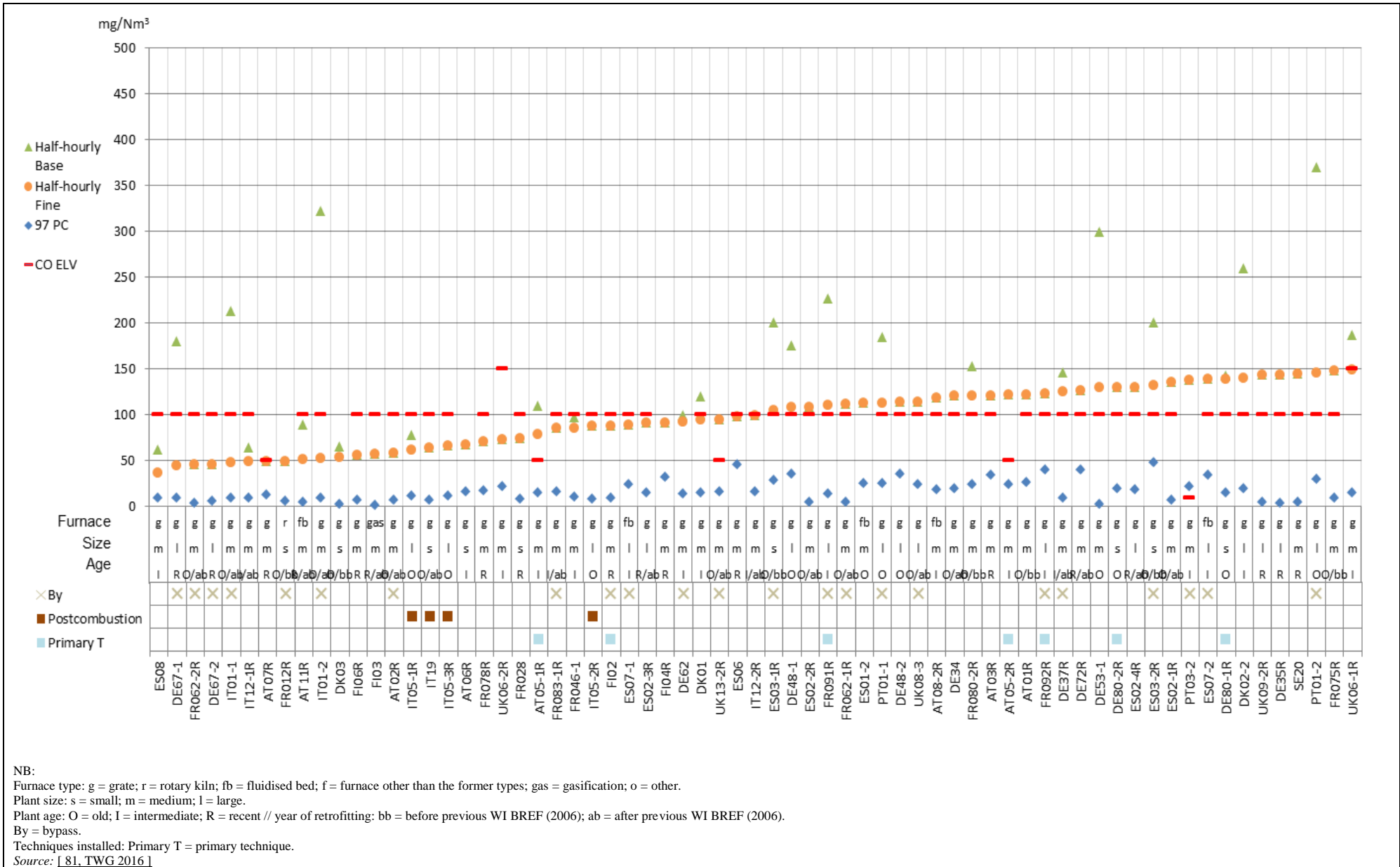

Figure 8.78: Half-hourly average emission levels for continuously monitored CO emissions to air from reference lines incinerating predominantly MSW (1/3)

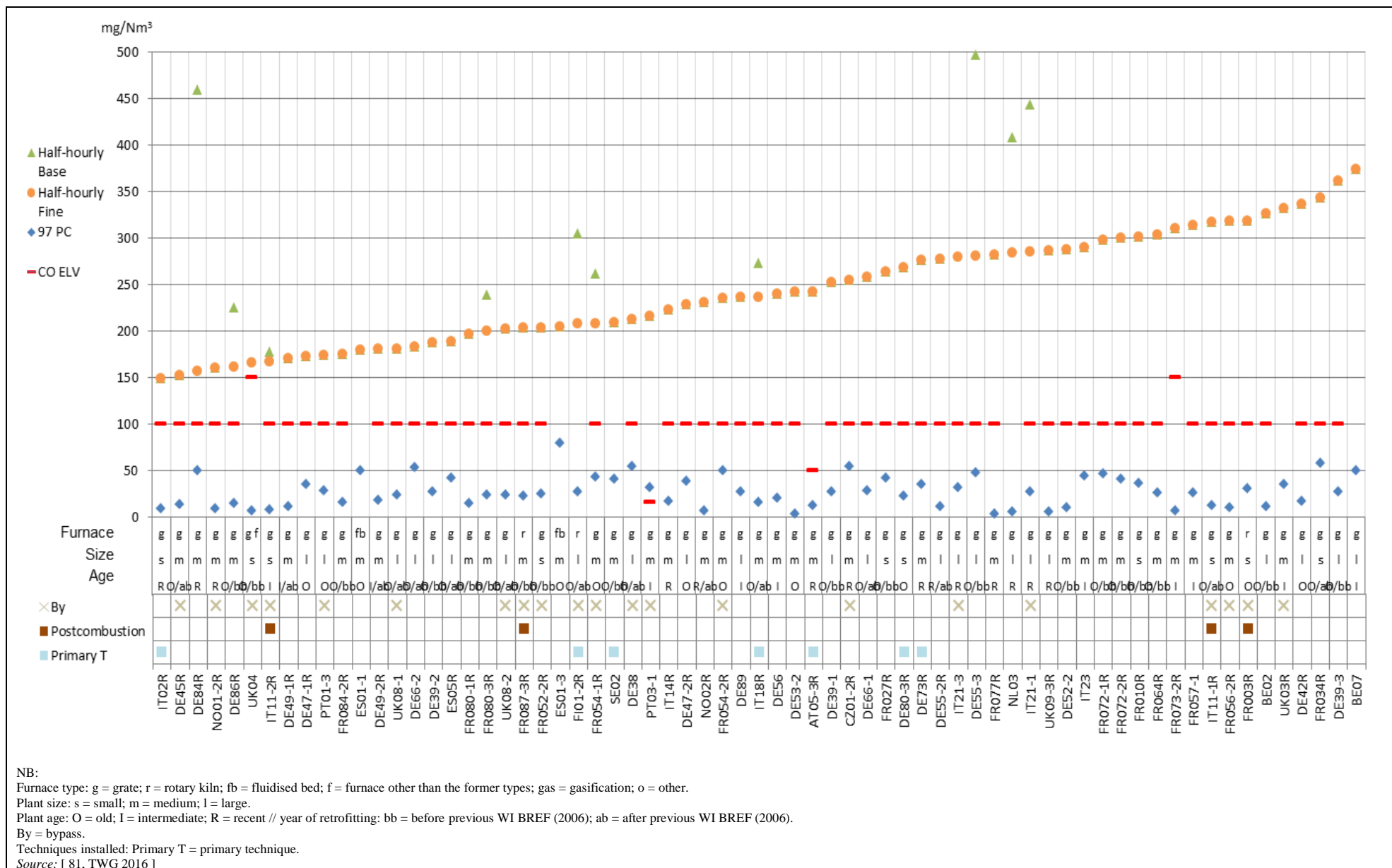
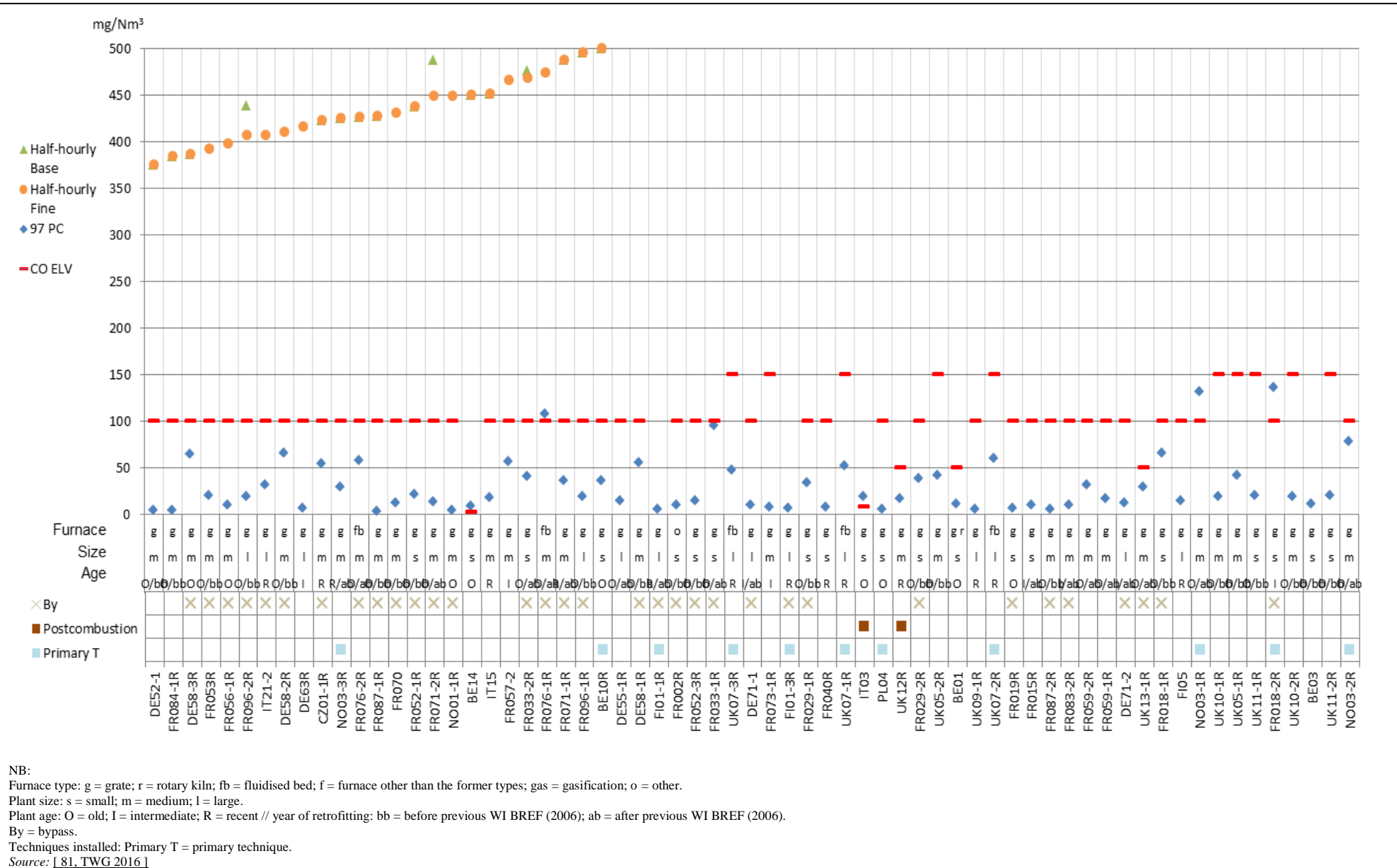

Figure 8.79: Half-hourly average emission levels for continuously monitored CO emissions to air from reference lines incinerating predominantly MSW (2/3)



NB:
Furnace type: g = grate; r = rotary kiln; fb = fluidised bed; f = furnace other than the former types; gas = gasification; o = other.
Plant size: s = small; m = medium; l = large.
Plant age: O = old; I = intermediate; R = recent // year of retrofitting: bb = before previous WI BREF (2006); ab = after previous WI BREF (2006).
By = bypass.
Techniques installed: Primary T = primary technique.
Source: [81, TWG 2016]

Figure 8.80: Half-hourly average emission levels for continuously monitored CO emissions to air from reference lines incinerating predominantly MSW (3/3)

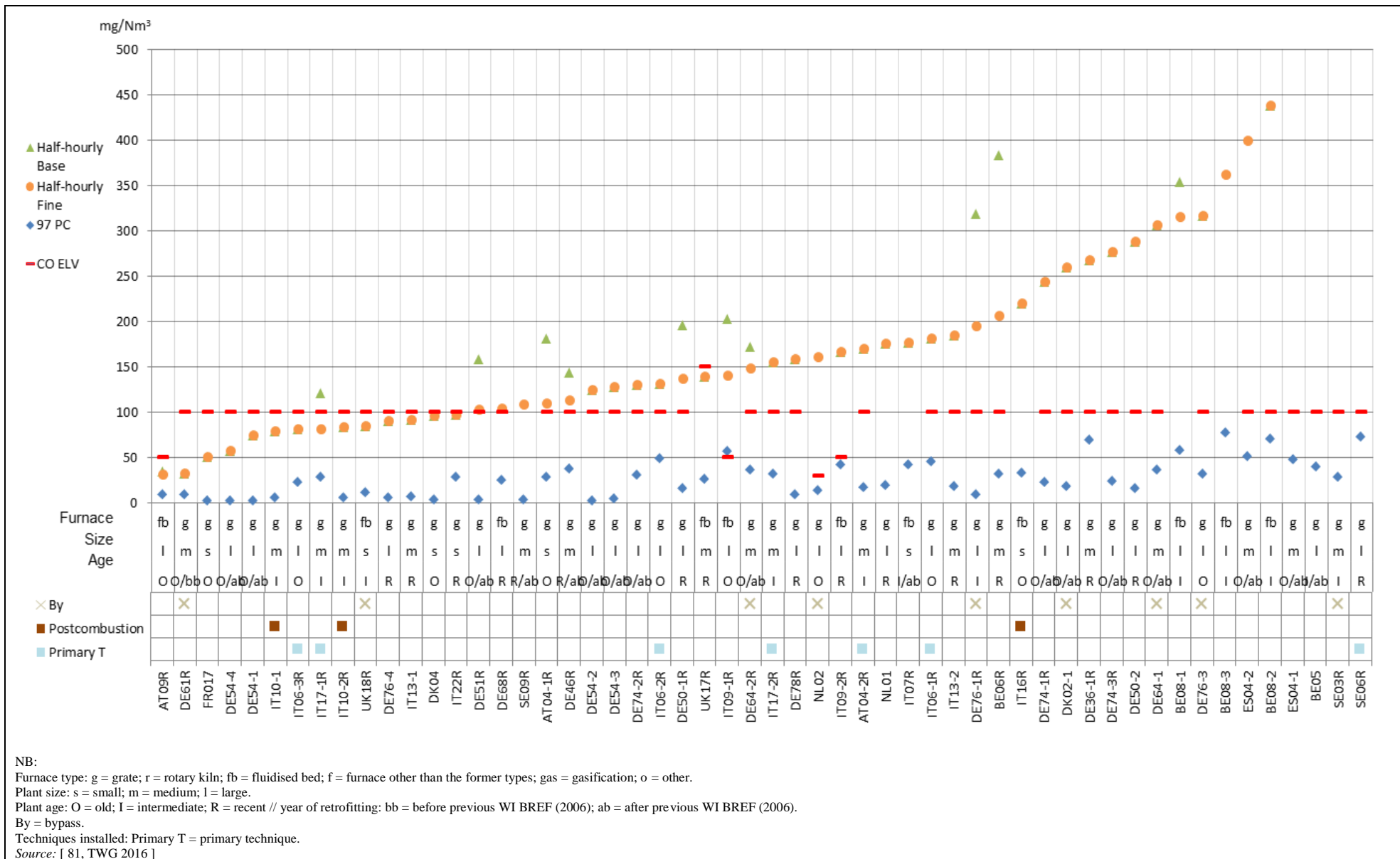

Figure 8.81: Half-hourly average emission levels for continuously monitored CO emissions to air from reference lines incinerating predominantly ONHW

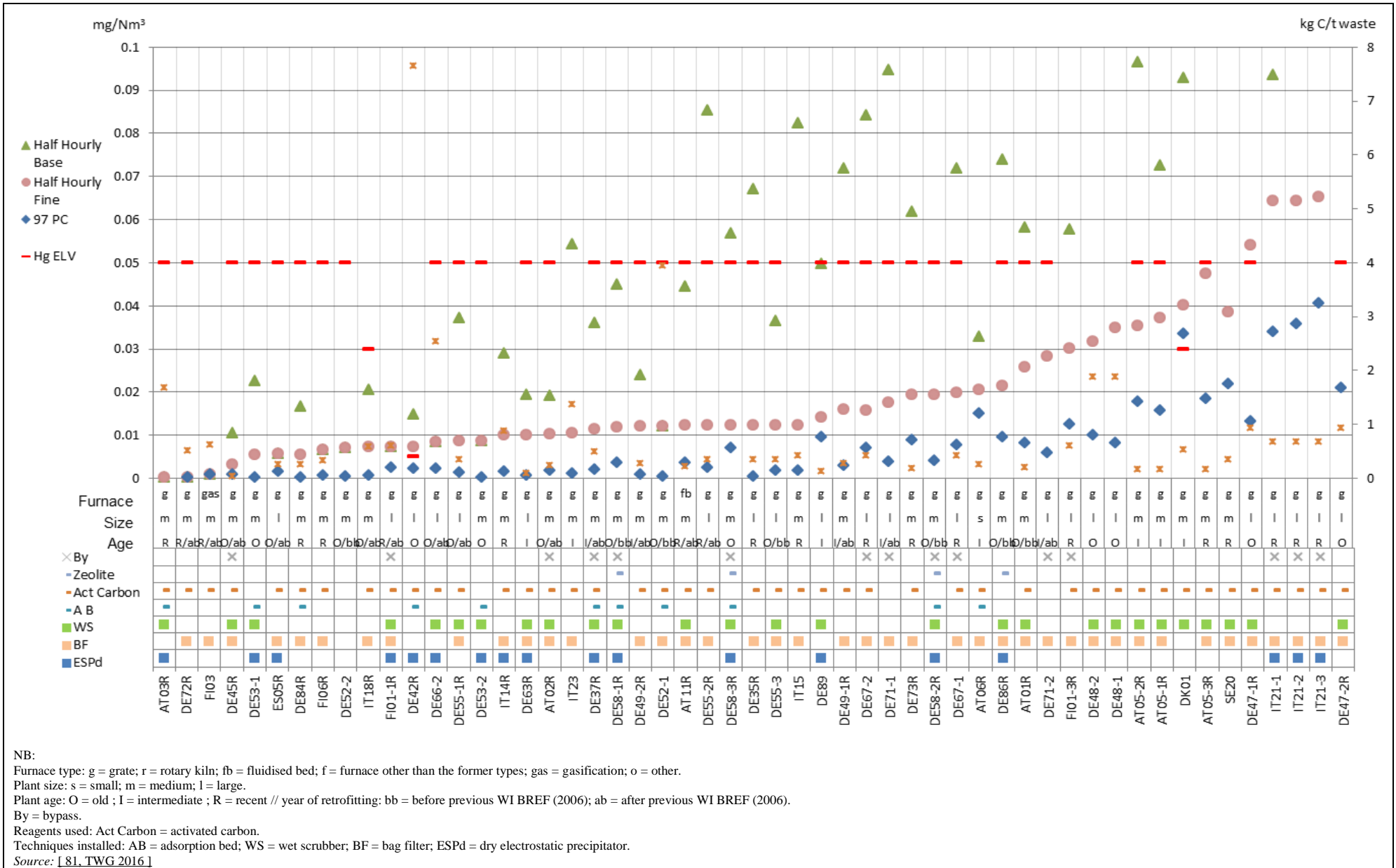

Figure 8.82: Half-hourly average emission levels for continuously monitored Hg emissions to air from reference lines incinerating predominantly MSW

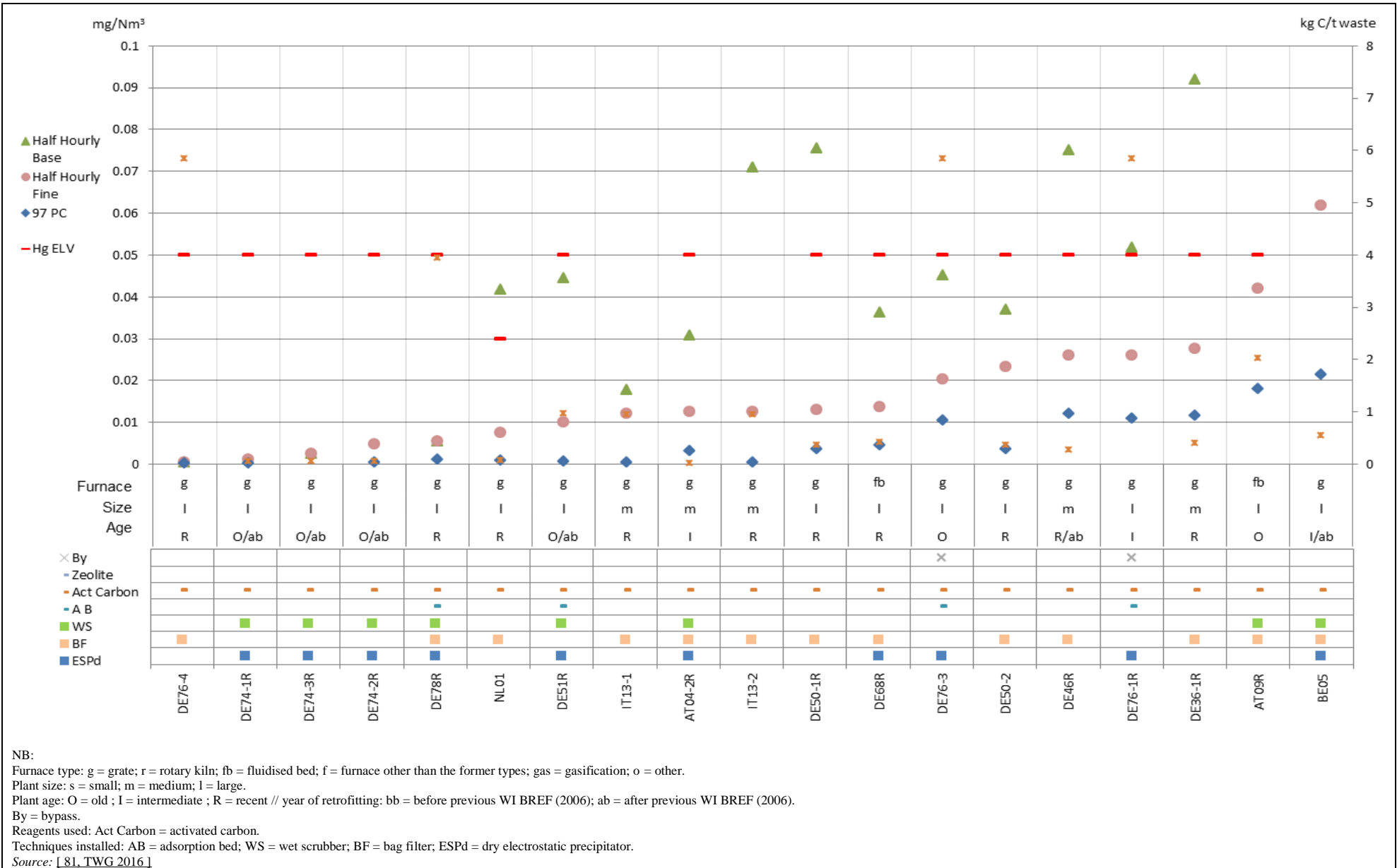

Figure 8.83: Half-hourly average emission levels for continuously monitored Hg emissions to air from reference lines incinerating predominantly ONHW

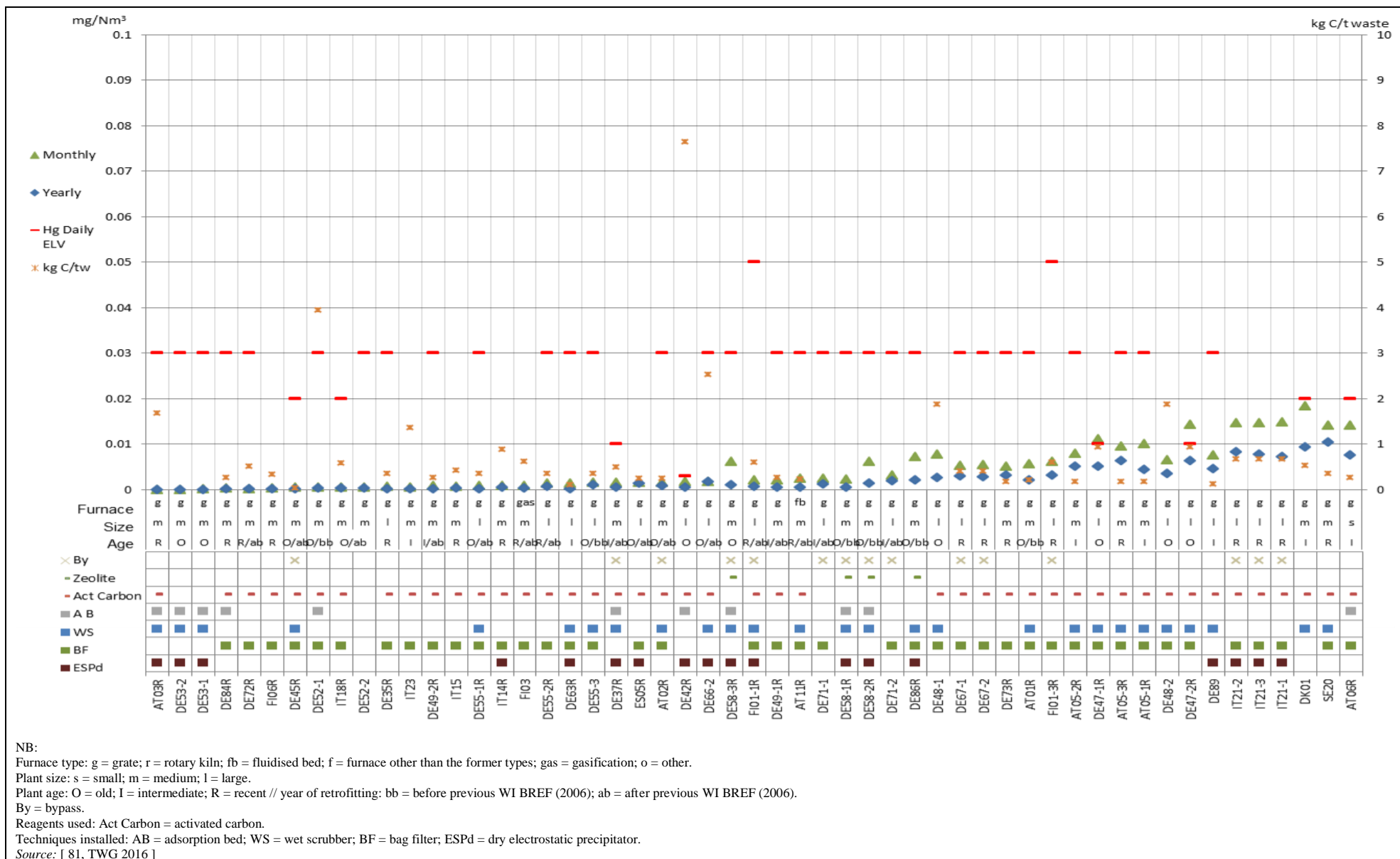

Figure 8.84: Monthly average emission levels for continuously monitored Hg emissions to air from reference lines incinerating predominantly MSW

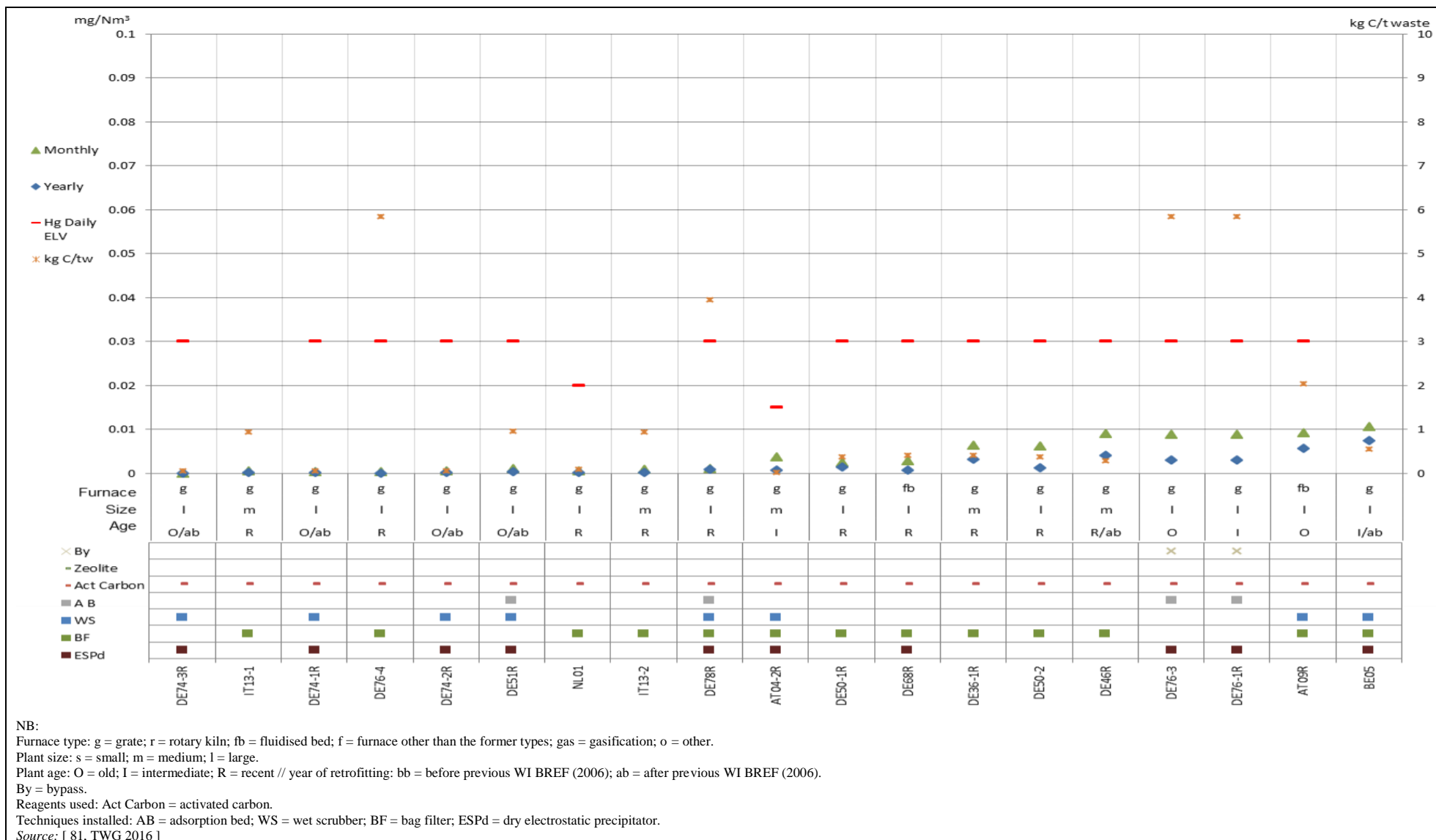

Figure 8.85: Monthly average emission levels for continuously monitored Hg emissions to air from reference lines incinerating predominantly ONHW

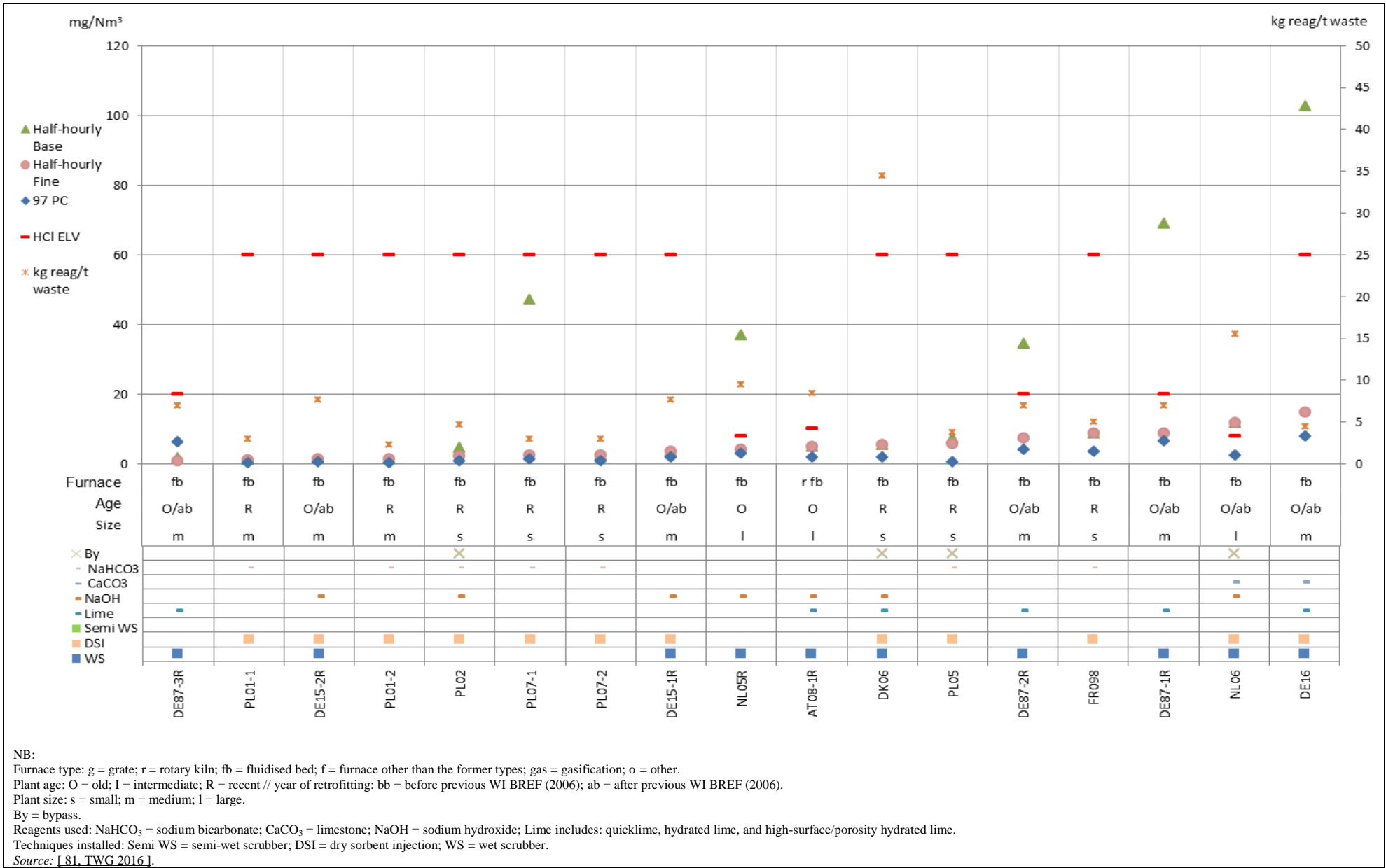

Figure 8.86: Half-hourly average emission levels for continuously monitored HCl emissions to air from reference lines incinerating predominantly SS

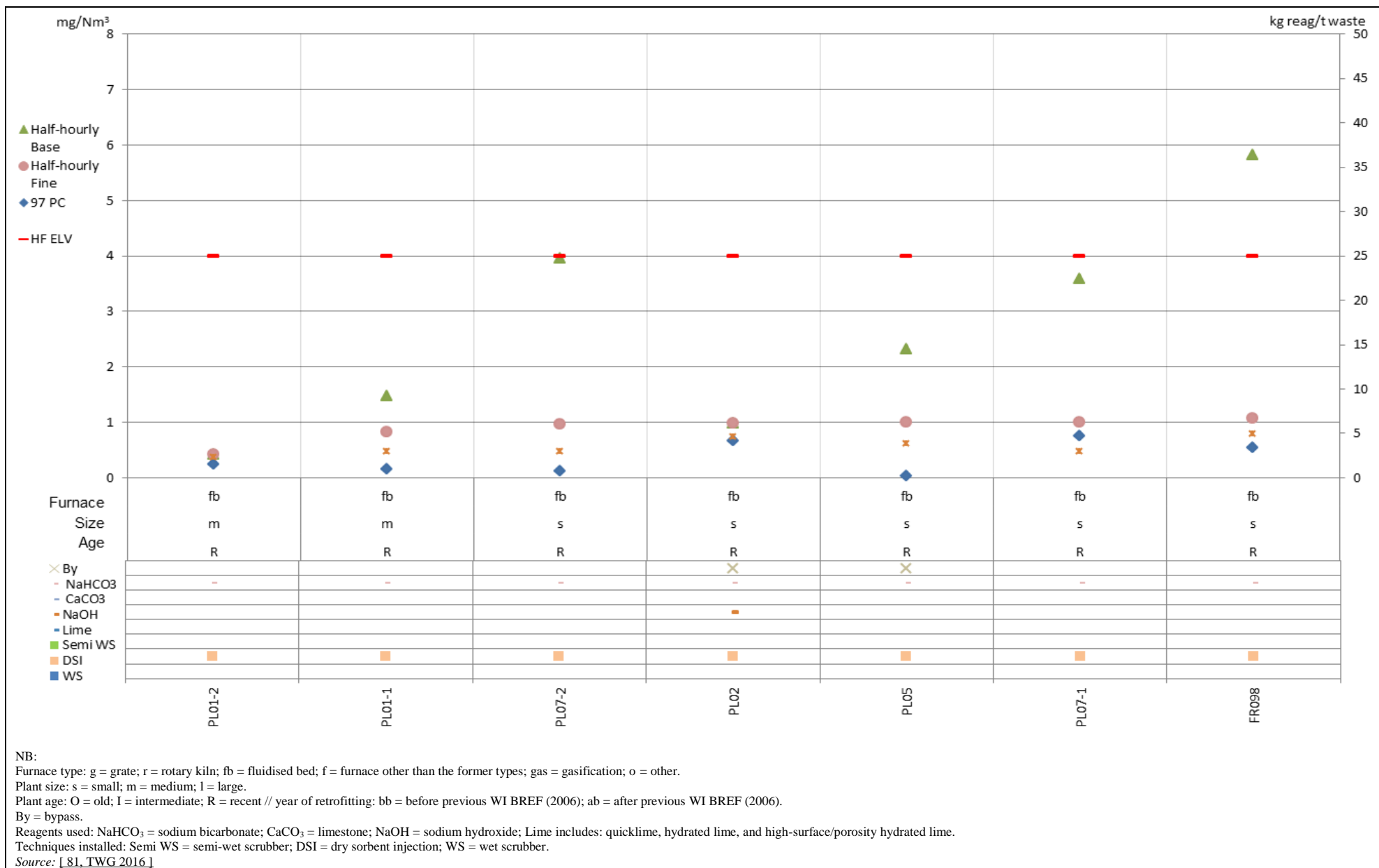

Figure 8.87: Half-hourly average emission levels for continuously monitored HF emissions to air from reference lines incinerating predominantly SS

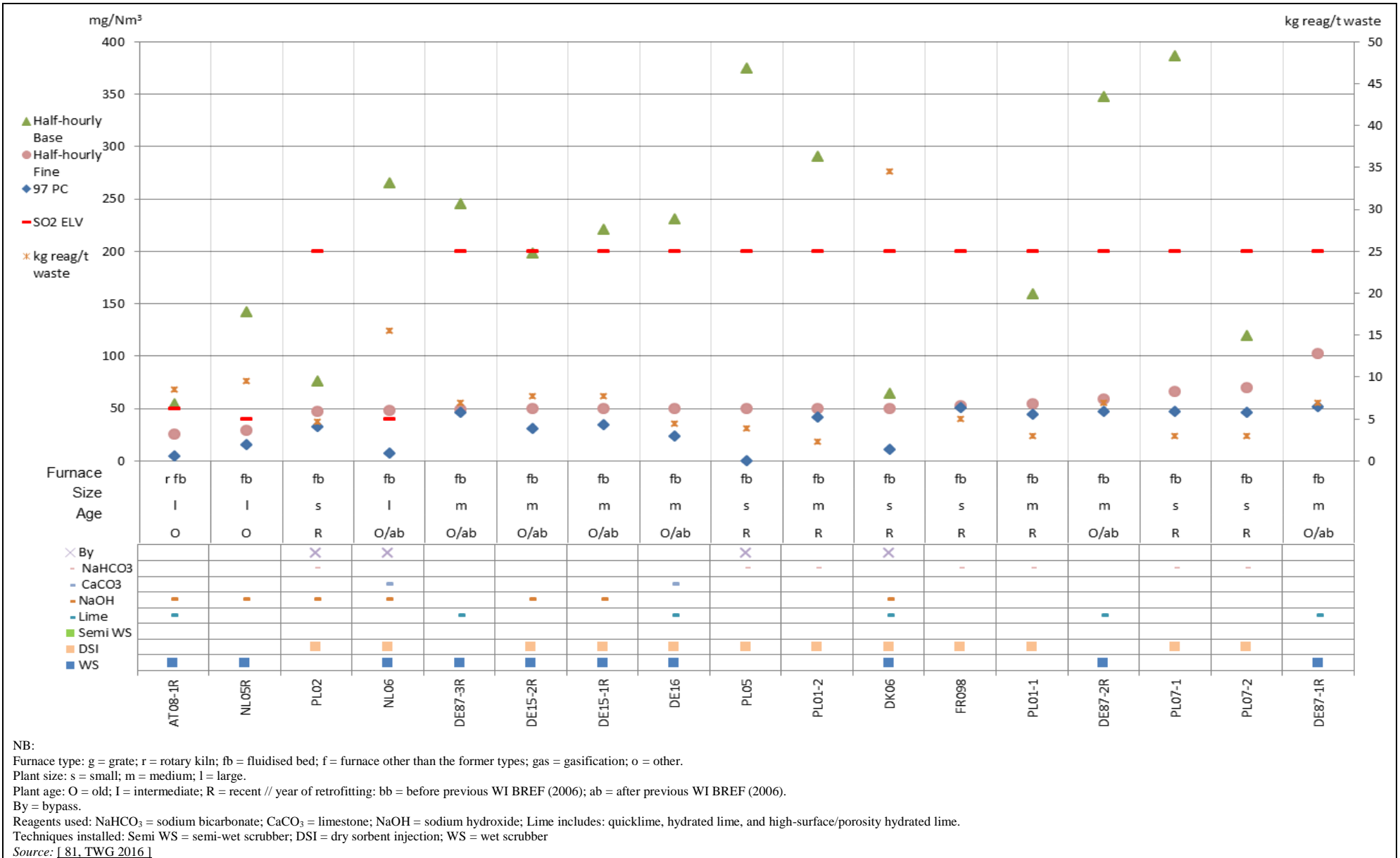

Figure 8.88: Half-hourly average emission levels for continuously monitored SO₂ emissions to air from reference lines incinerating predominantly SS

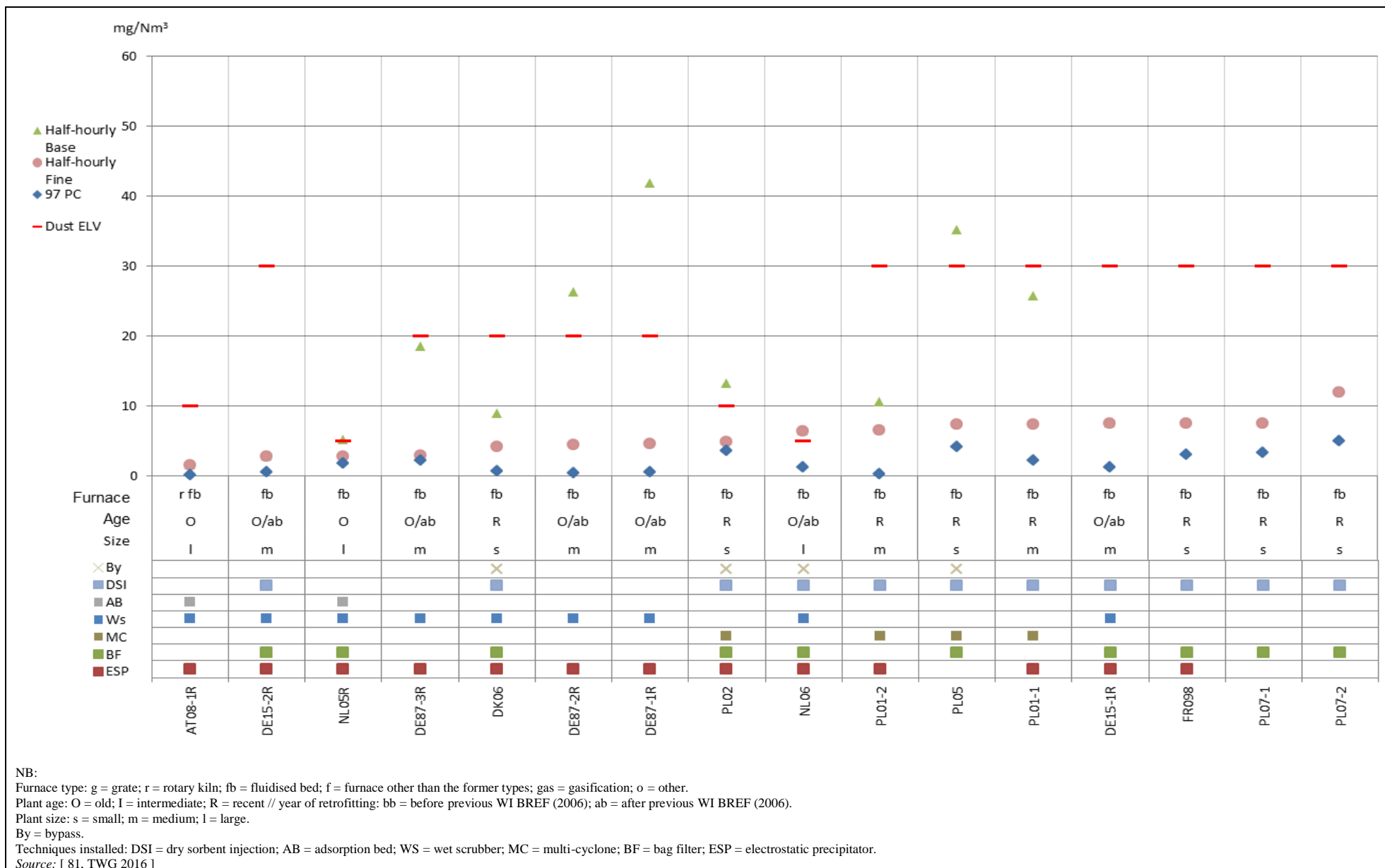
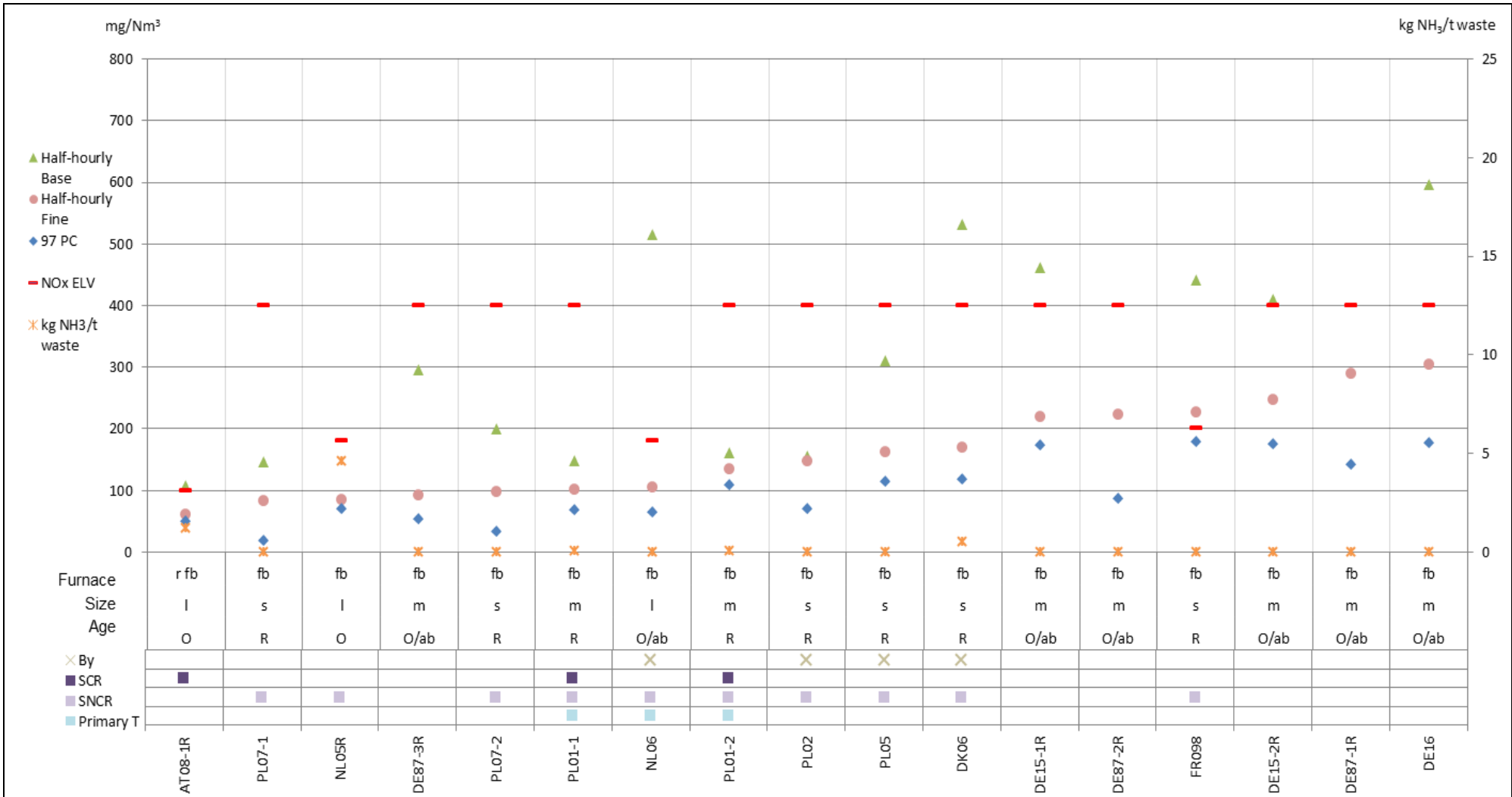

Figure 8.89: Half-hourly average emission levels for continuously monitored dust emissions to air from reference lines incinerating predominantly SS



NB:
 Furnace type: g = grate; r = rotary kiln; fb = fluidised bed; f = furnace other than the former types; gas = gasification; o = other.
 Plant size: s = small; m = medium; l = large.
 Plant age: O = old; I = intermediate; R = recent // year of retrofitting; bb = before previous WI BREF (2006); ab = after previous WI BREF (2006).
 By = bypass.
 Techniques installed: SCR = selective catalytic reduction; SNCR = selective non-catalytic reduction; Primary T = primary technique.
 Source: [81, TWG 2016]

Figure 8.90: Half-hourly average emission levels for continuously monitored NO_x emissions to air from reference lines incinerating predominantly SS

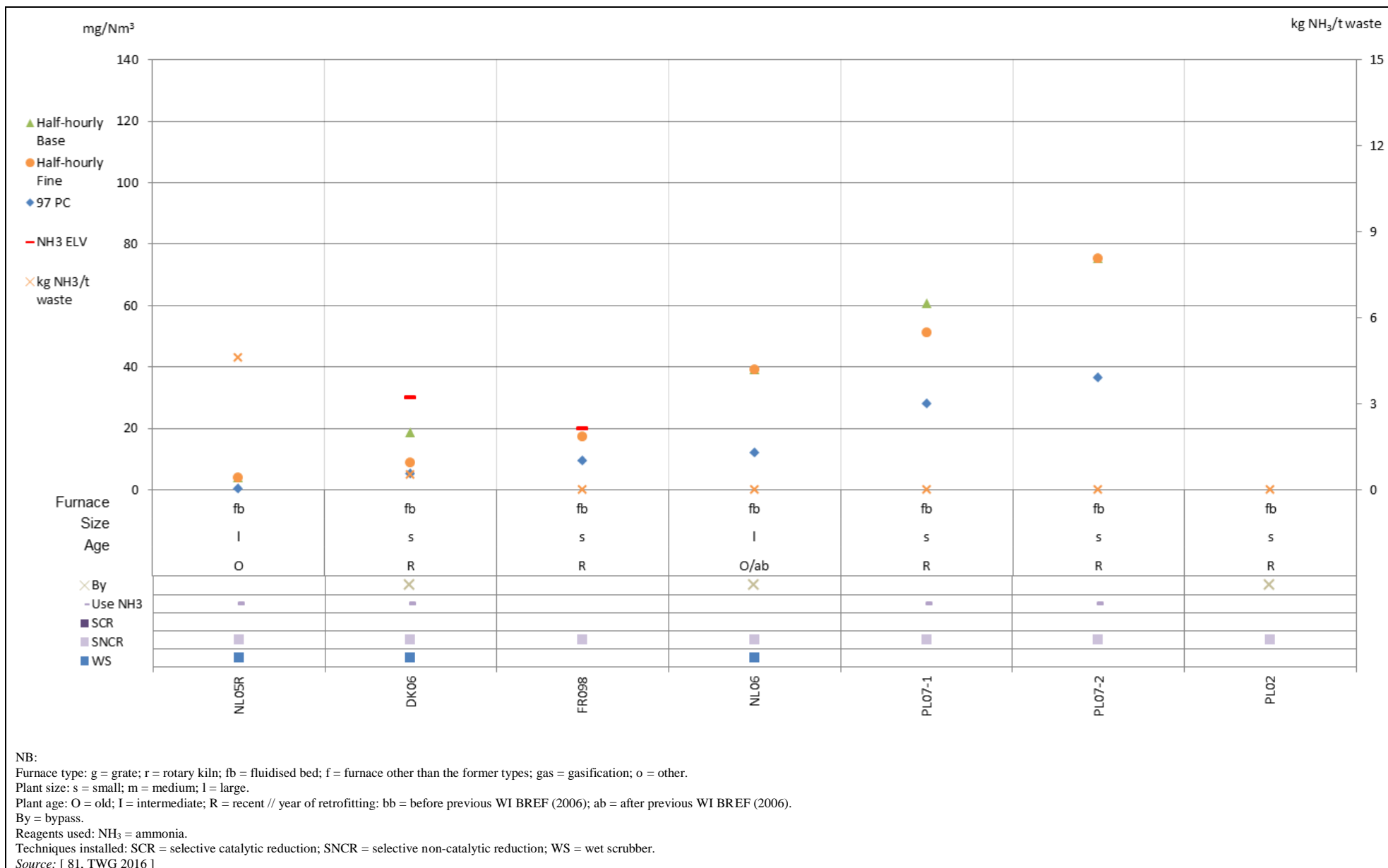

Figure 8.91: Half-hourly average emission levels for continuously monitored NH₃ emissions to air from reference lines incinerating predominantly SS

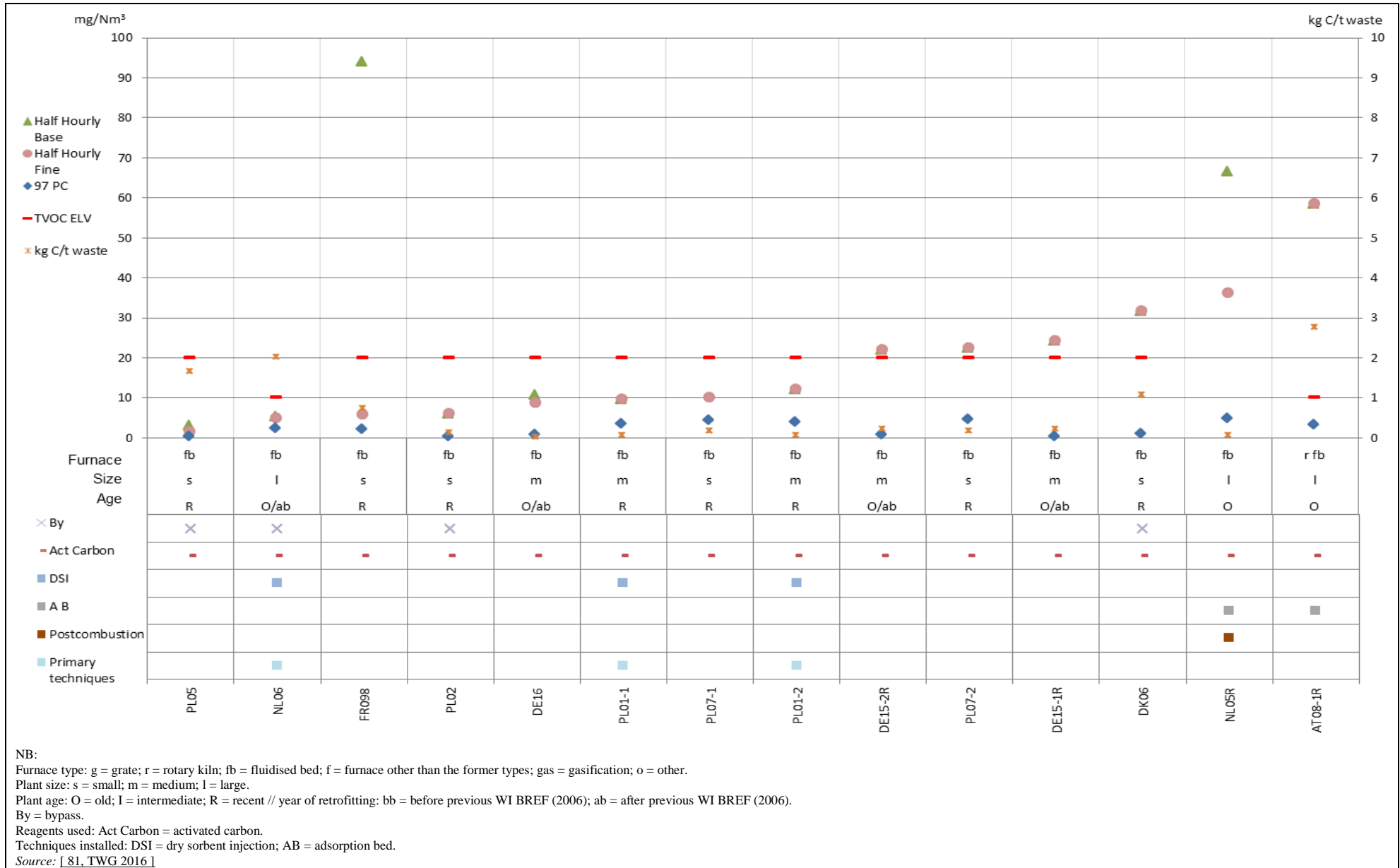

Figure 8.92: Half-hourly average emission levels for continuously monitored TVOC emissions to air from reference lines incinerating predominantly SS

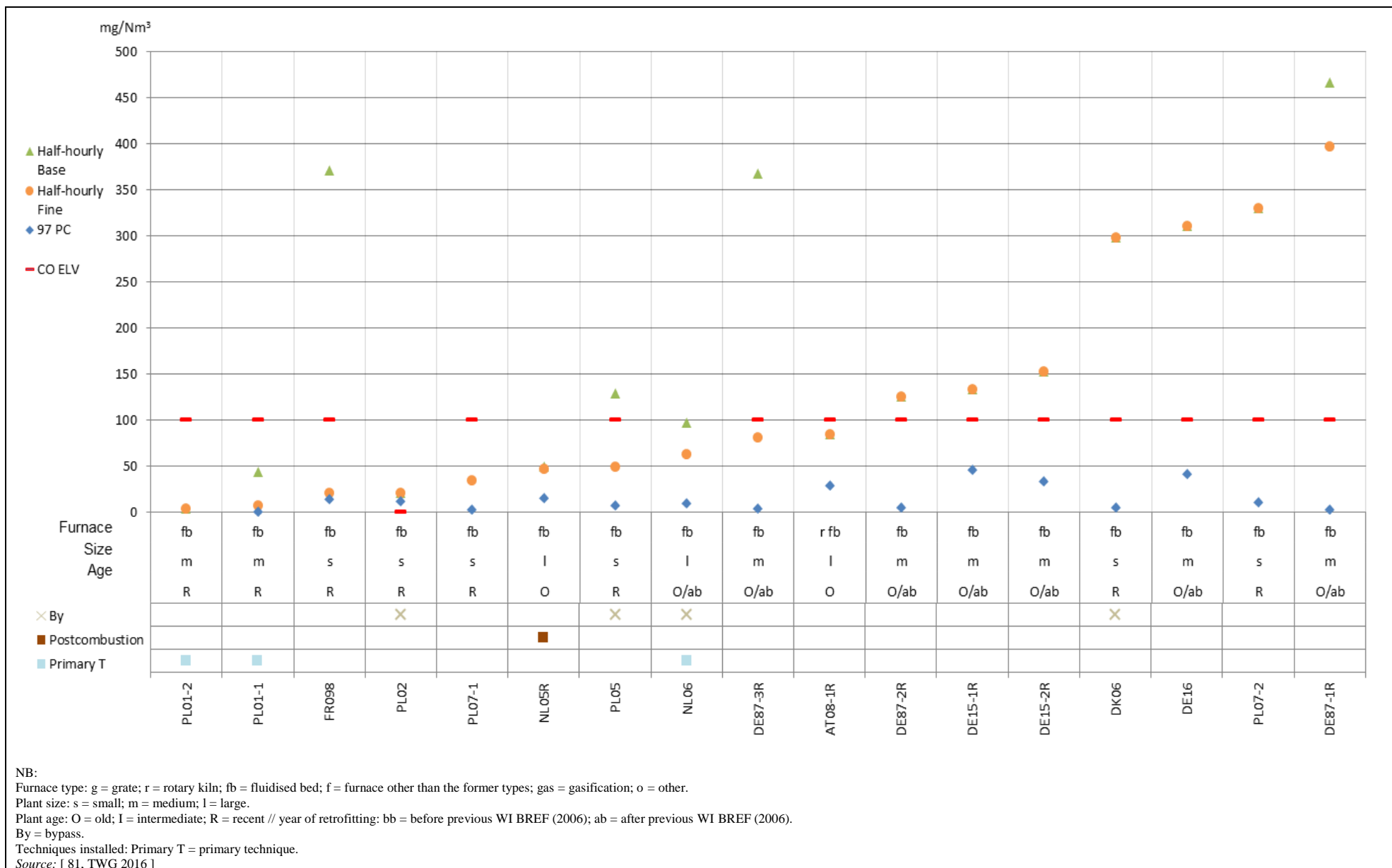

Figure 8.93: Half-hourly average emission levels for continuously monitored CO emissions to air from reference lines incinerating predominantly SS

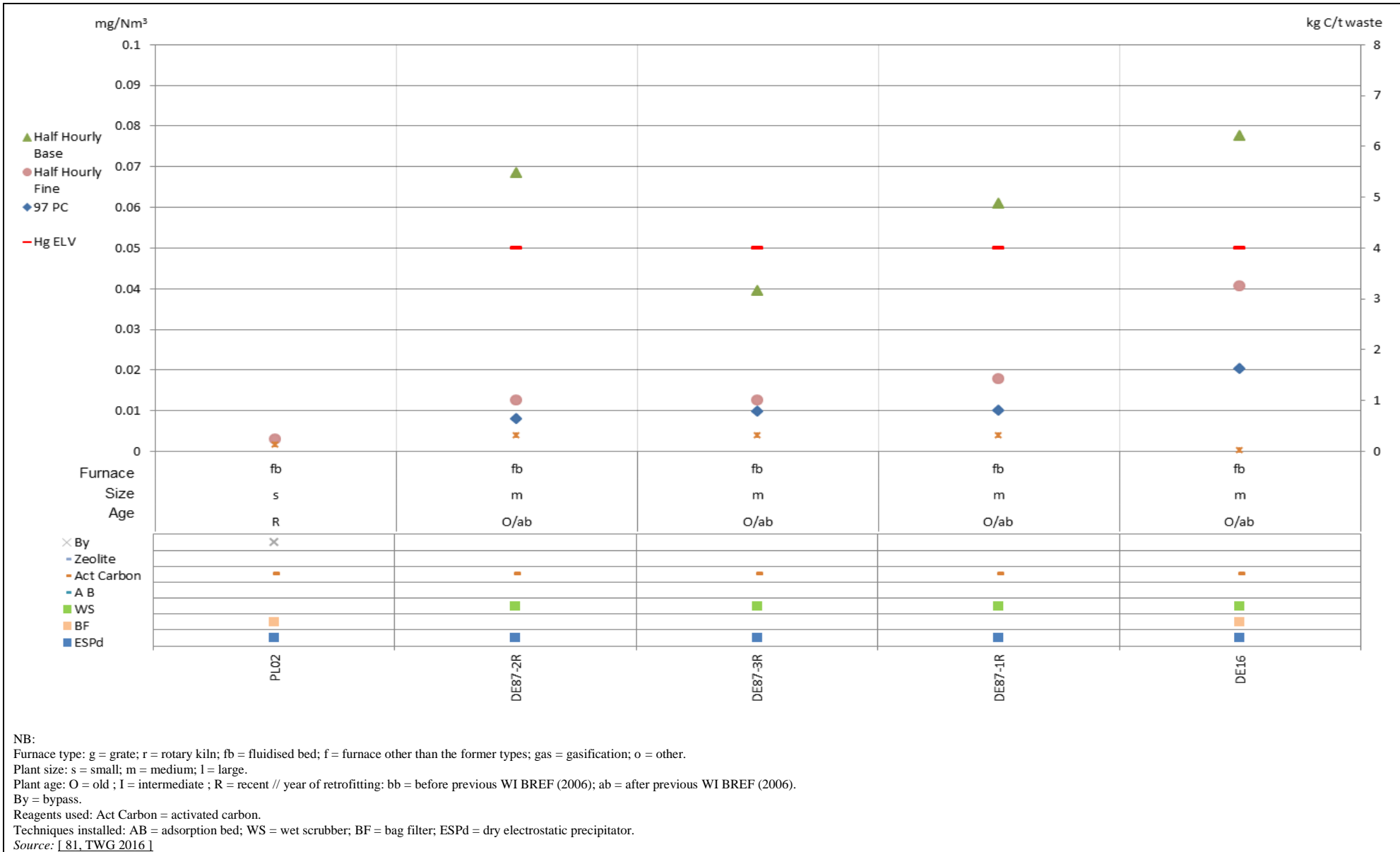

Figure 8.94: Half-hourly average emission levels for continuously monitored Hg emissions to air from reference lines incinerating predominantly SS

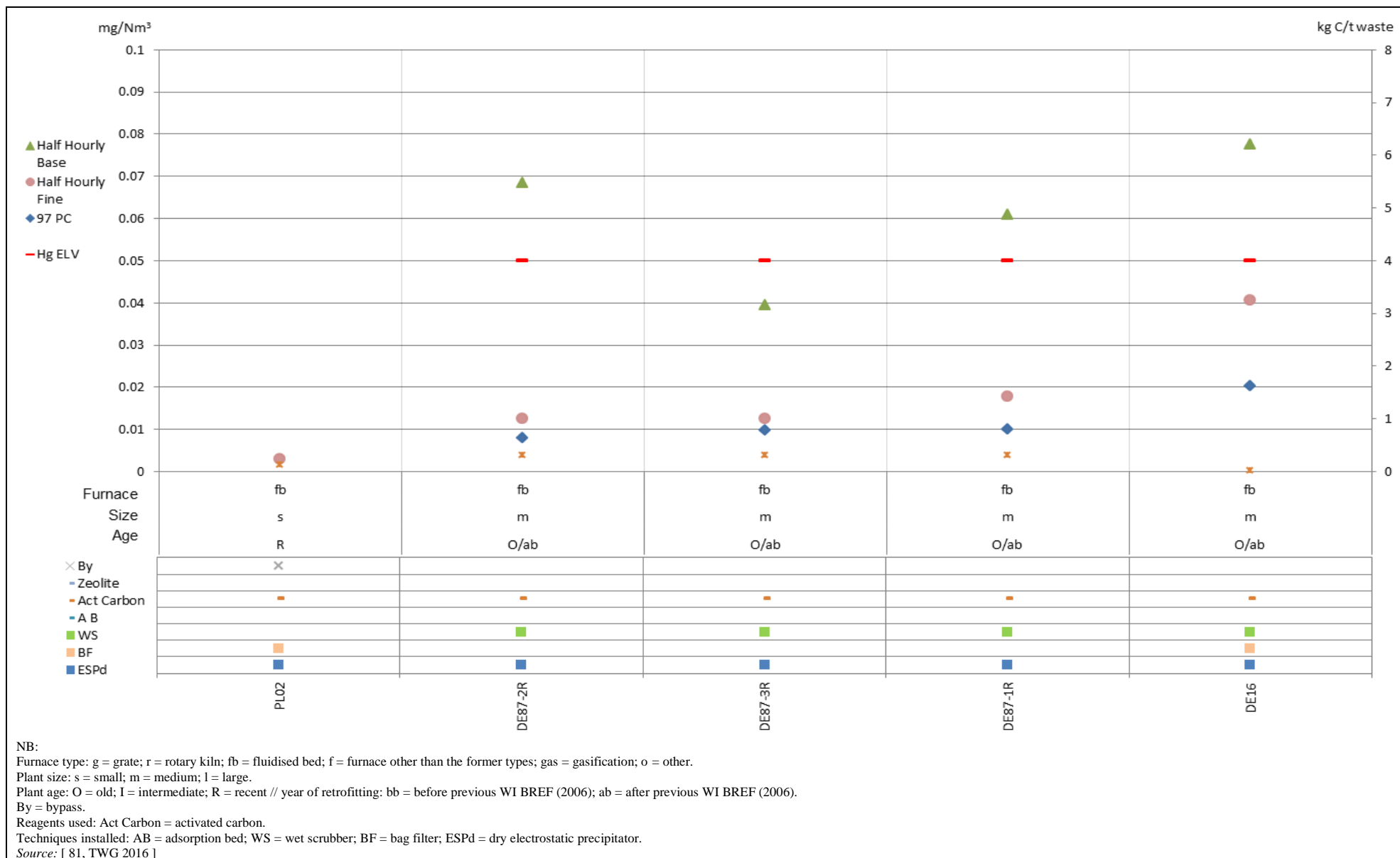

Figure 8.95: Monthly average emission levels for continuously monitored Hg emissions to air from reference lines incinerating predominantly SS

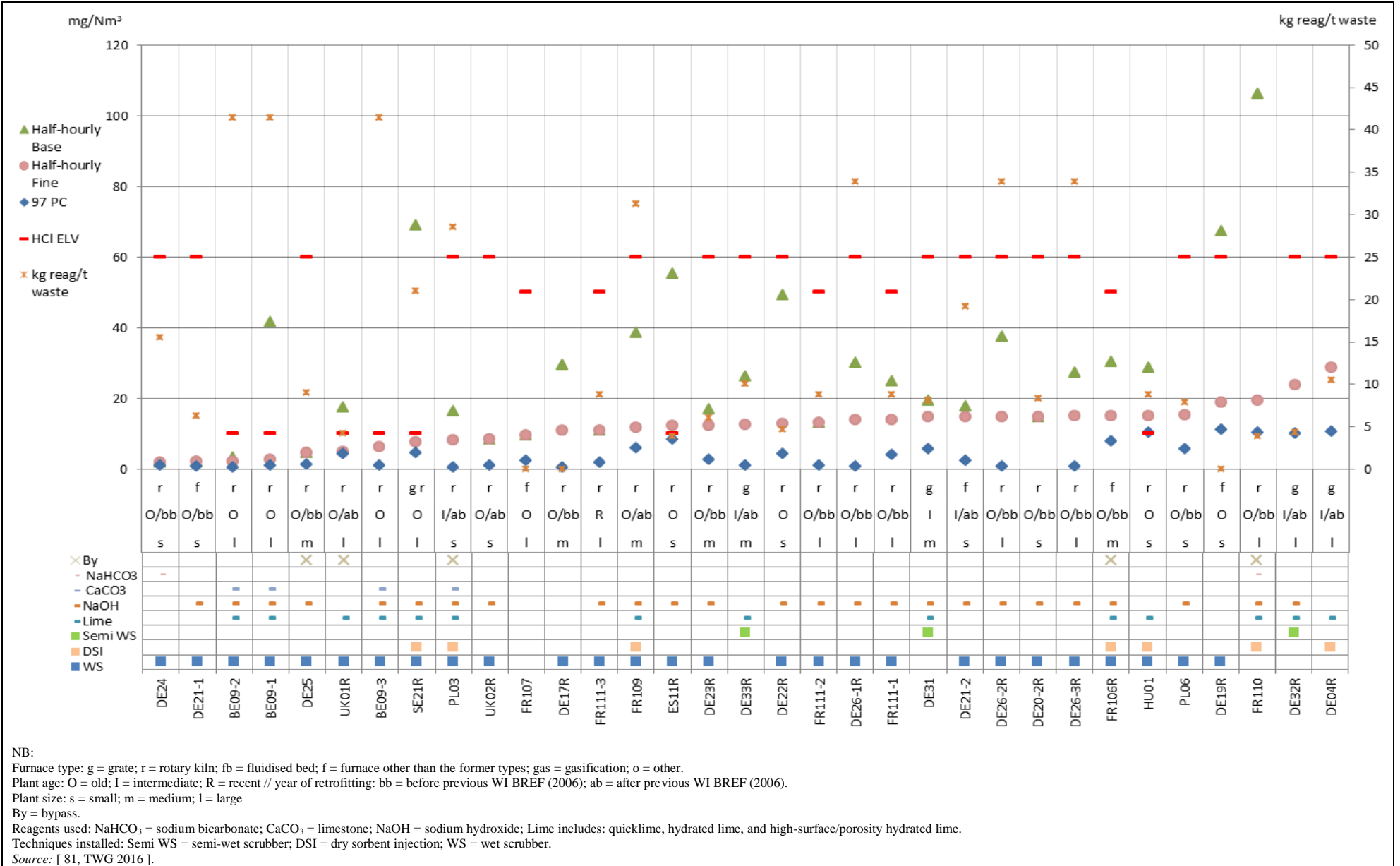

Figure 8.96: Half-hourly average emission levels for continuously monitored HCl emissions to air from reference lines incinerating predominantly HW

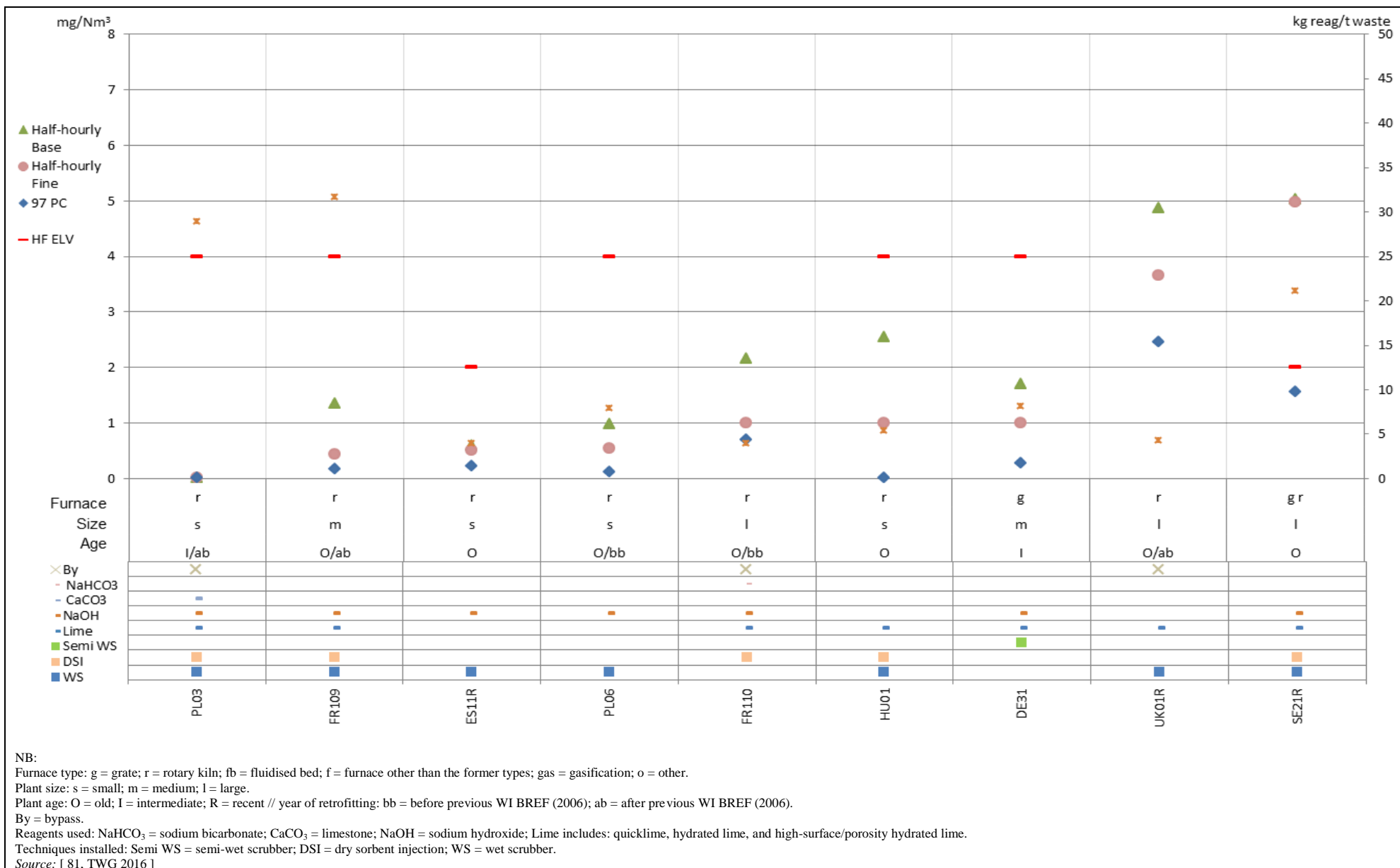

Figure 8.97: Half-hourly average emission levels for continuously monitored HF emissions to air from reference lines incinerating predominantly HW

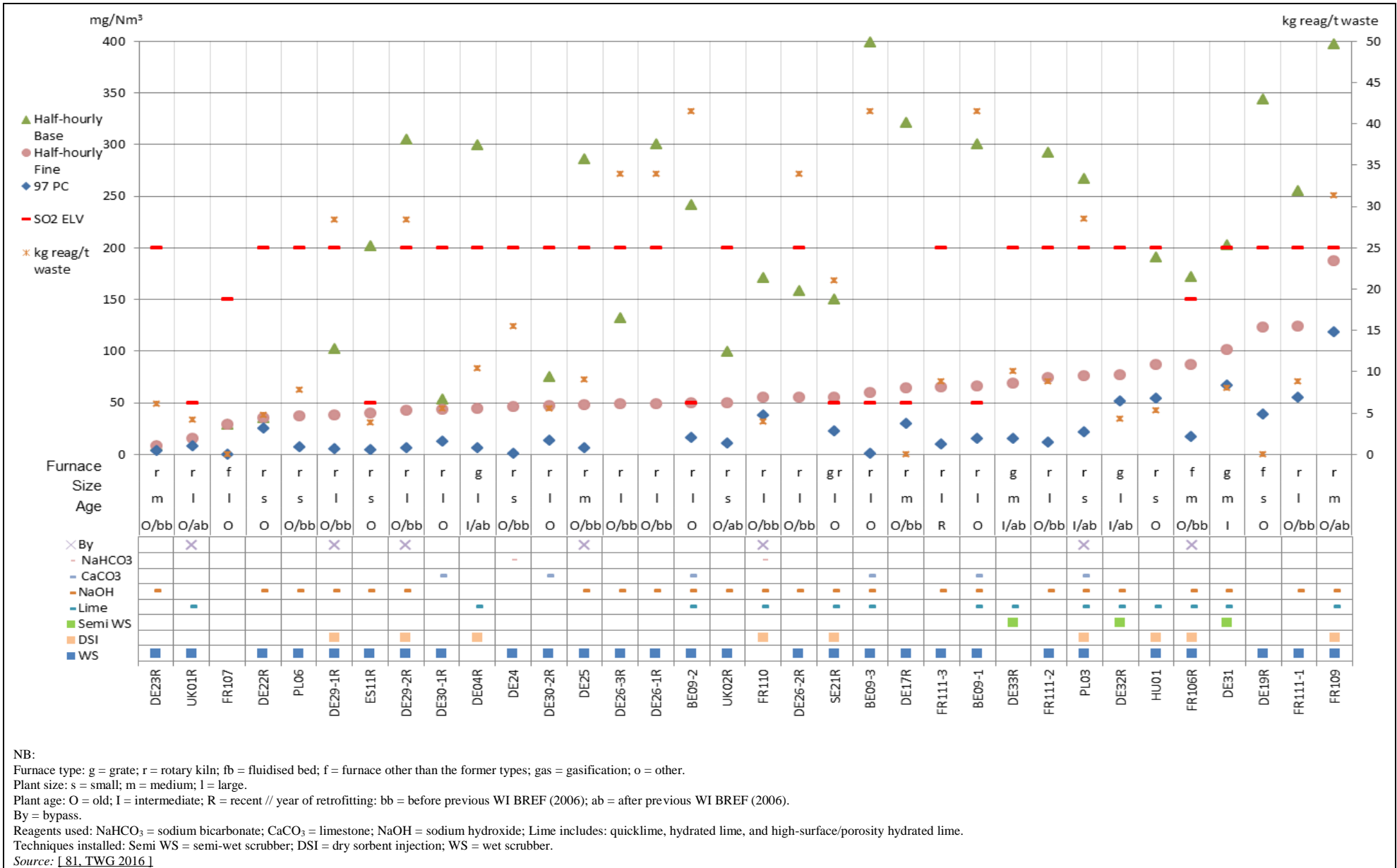

Figure 8.98: Half-hourly average emission levels for continuously monitored SO₂ emissions to air from reference lines incinerating predominantly HW

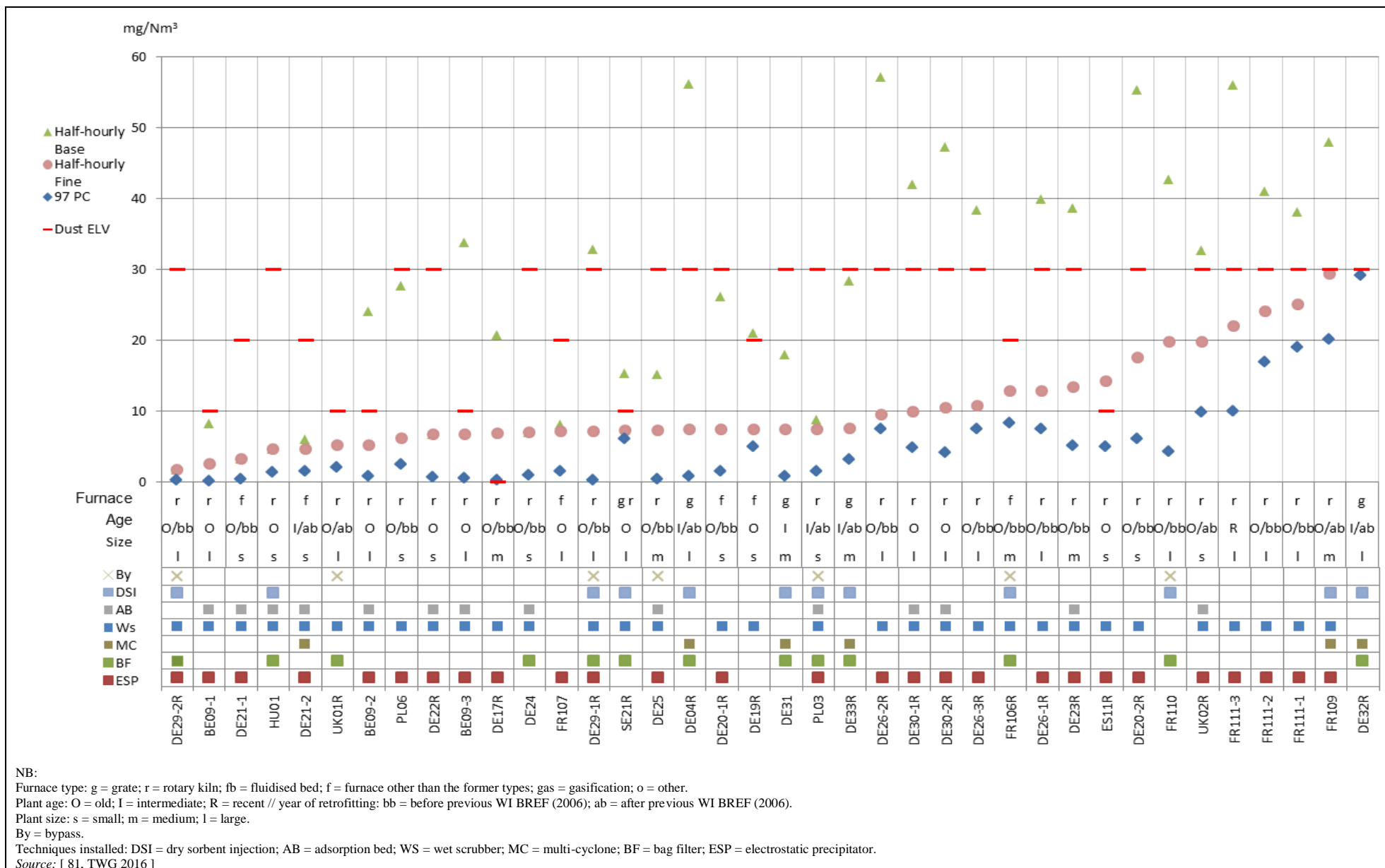

Figure 8.99: Half-hourly average emission levels for continuously monitored dust emissions to air from reference lines incinerating predominantly HW

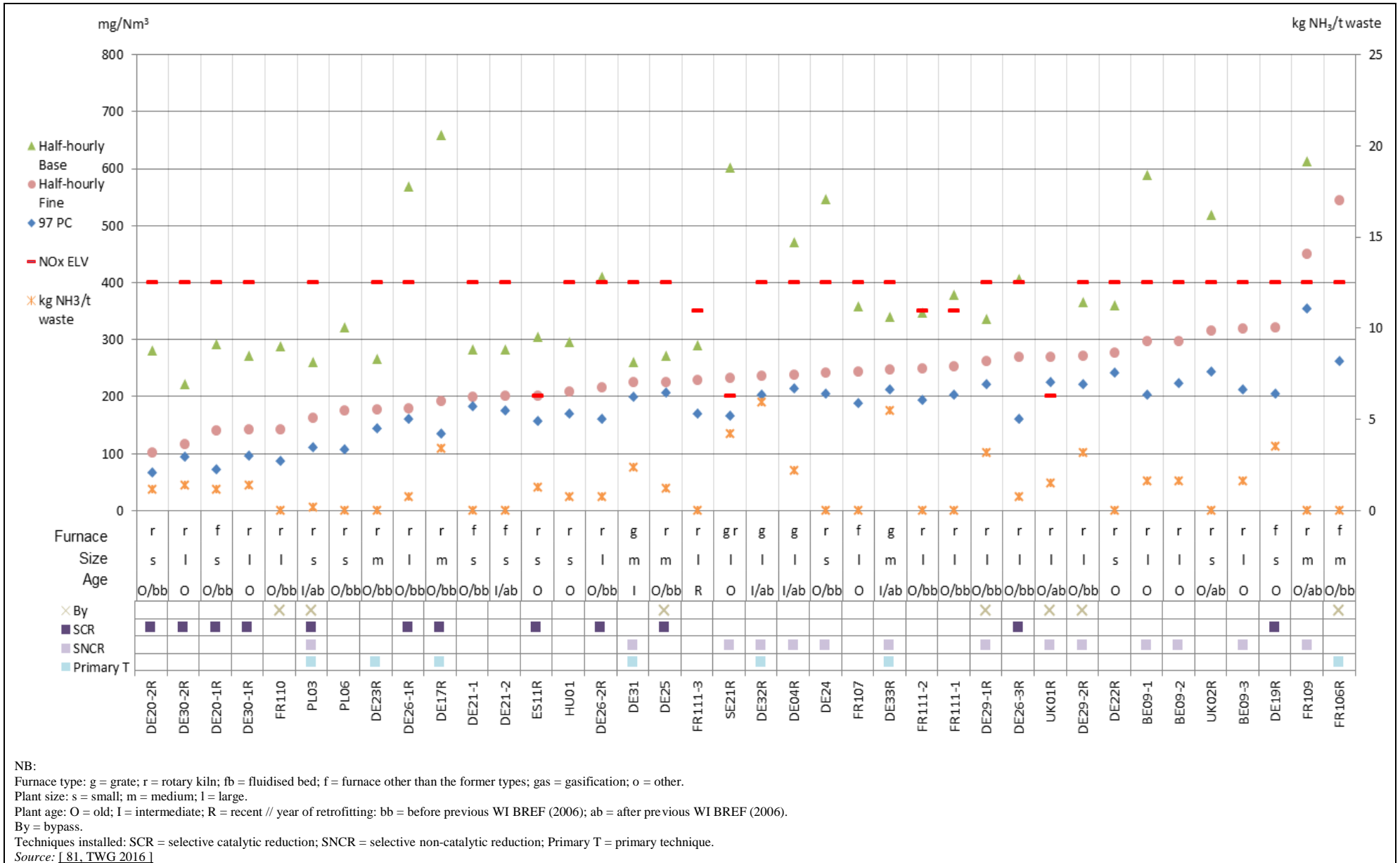

Figure 8.100: Half-hourly average emission levels for continuously monitored NO_x emissions to air from reference lines incinerating predominantly HW

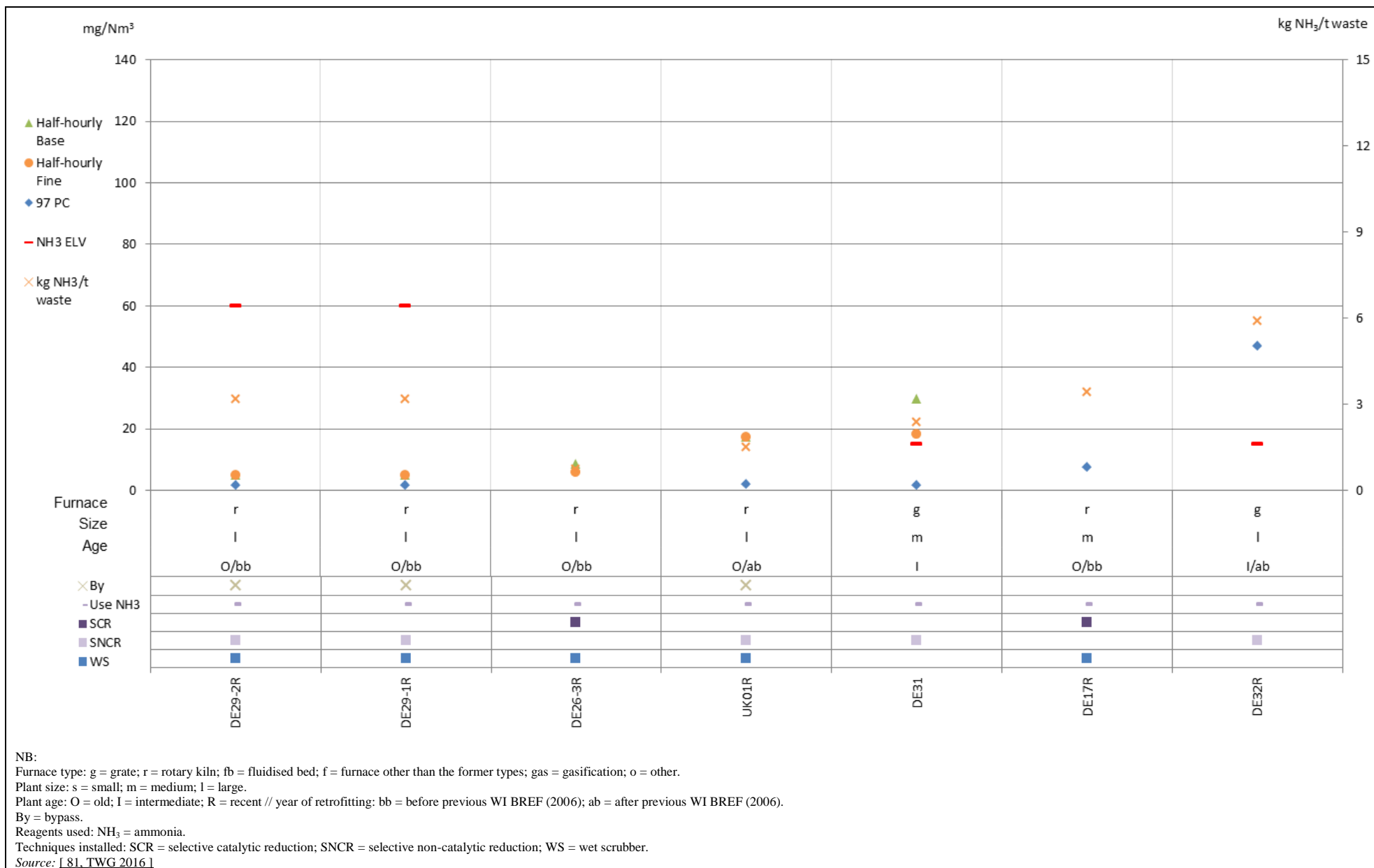

Figure 8.101: Half-hourly average emission levels for continuously monitored NH₃ emissions to air from reference lines incinerating predominantly HW

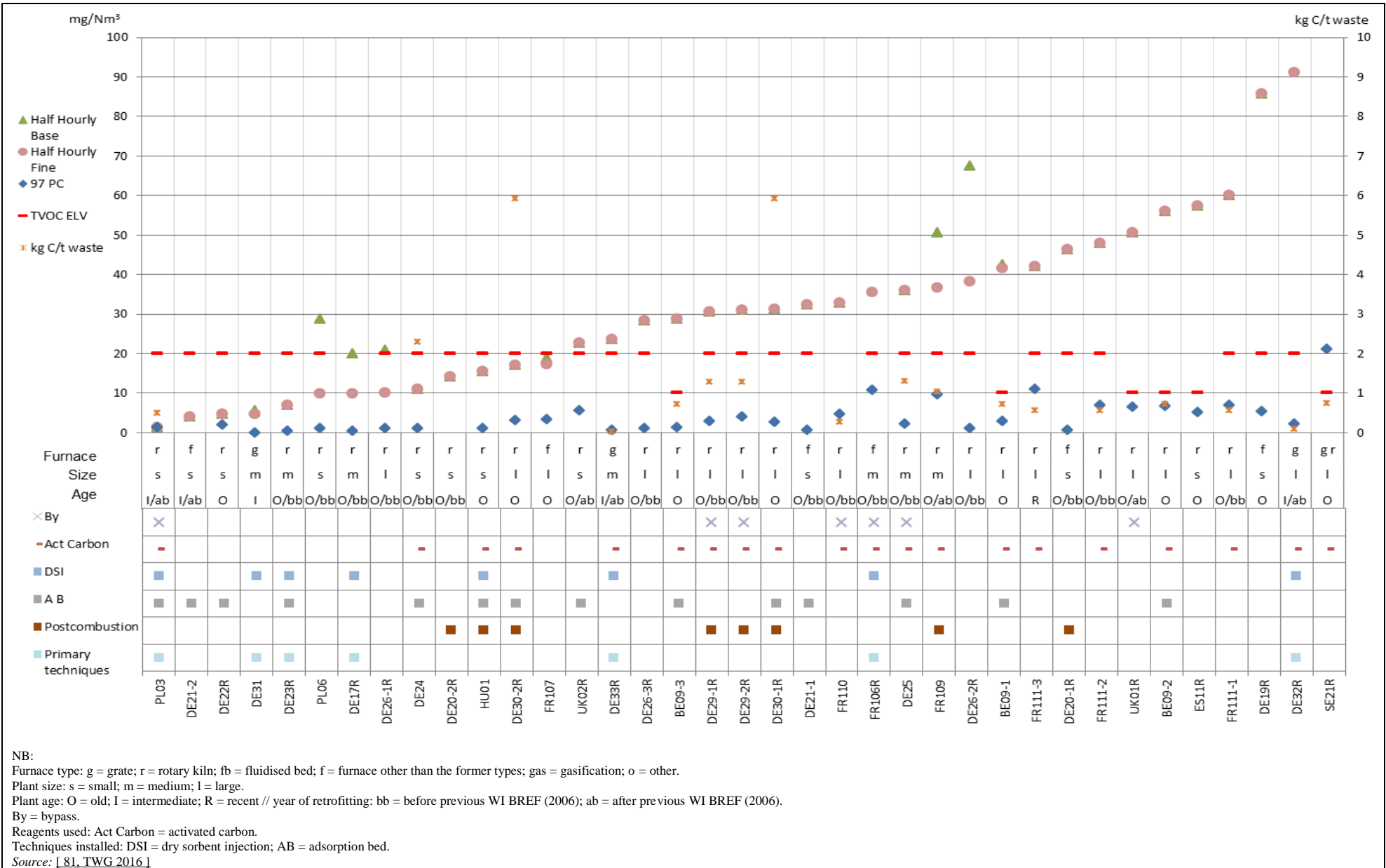

Figure 8.102: Half-hourly average emission levels for continuously monitored TVOC emissions to air from reference lines incinerating predominantly HW

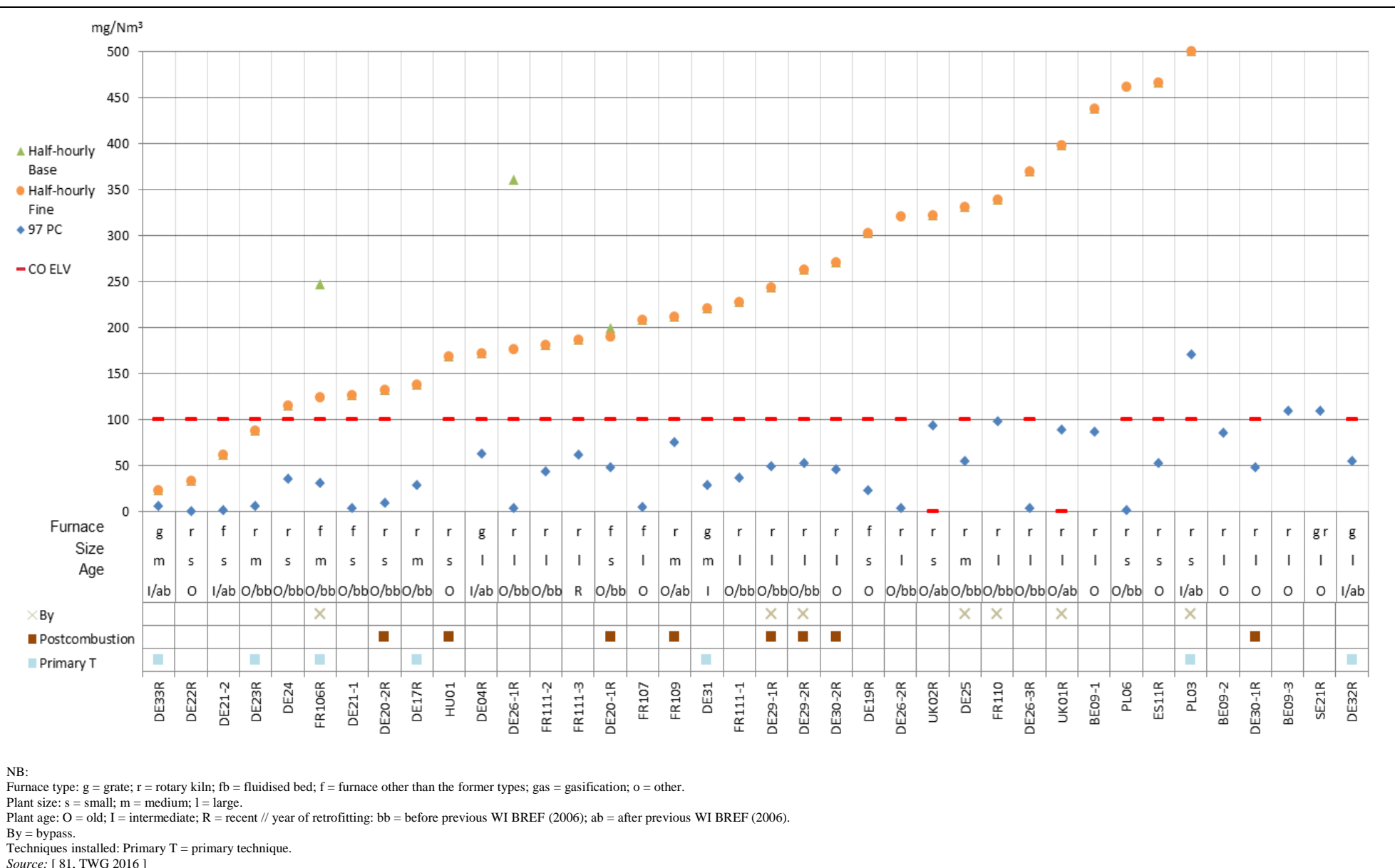

Figure 8.103: Half-hourly average emission levels for continuously monitored CO emissions to air from reference lines incinerating predominantly HW

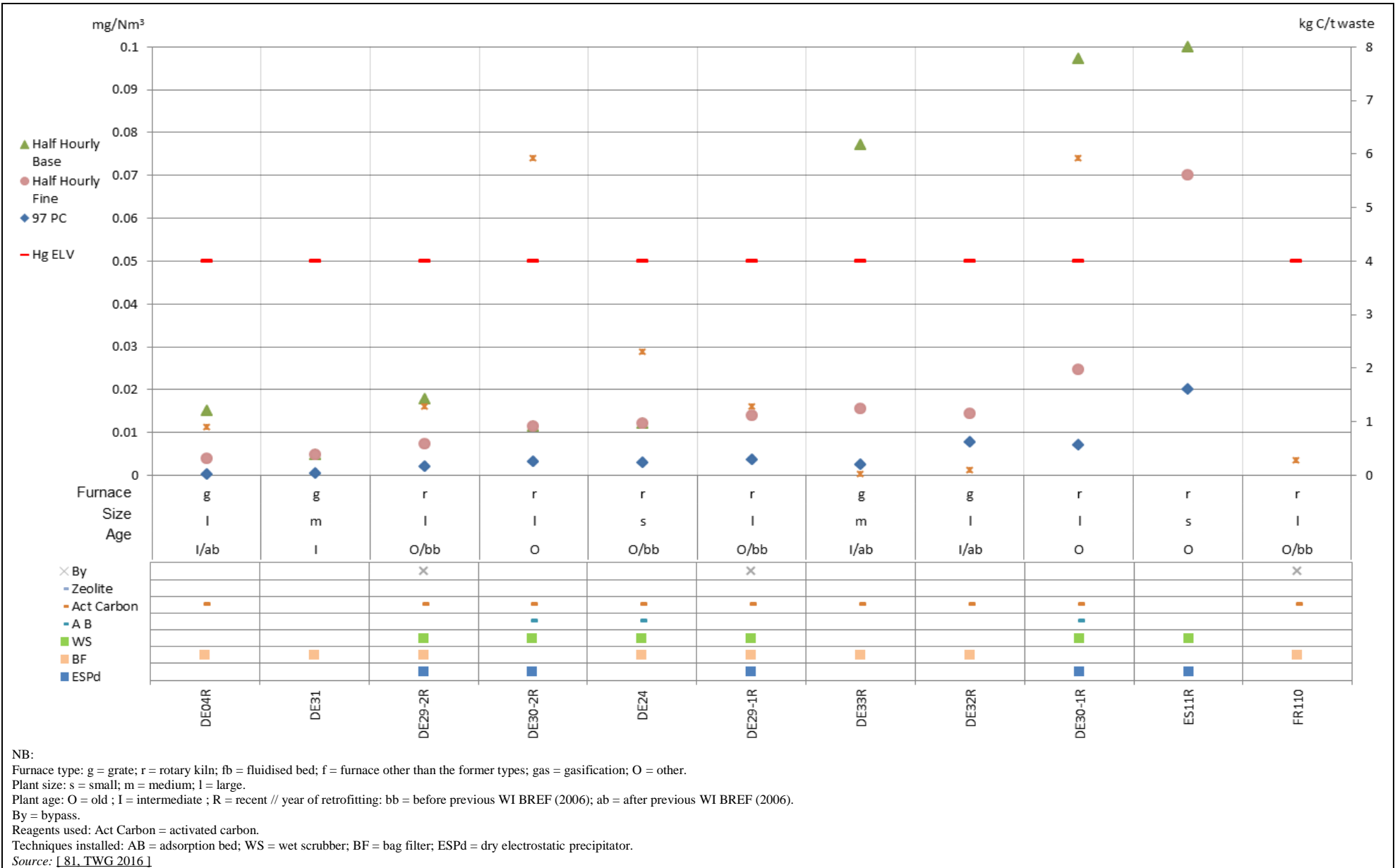

Figure 8.104: Half-hourly average emission levels for continuously monitored Hg emissions to air from reference lines incinerating predominantly HW

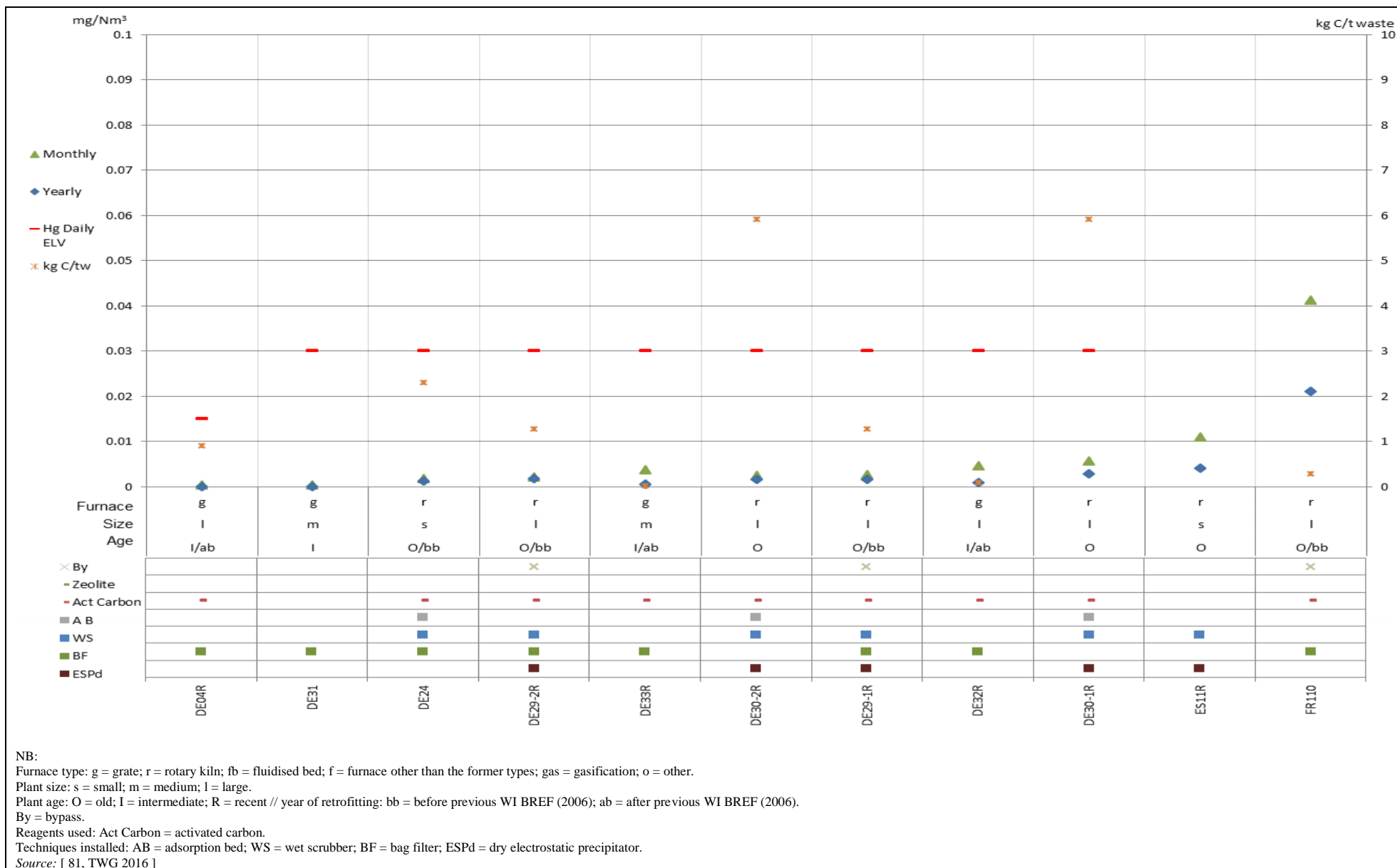

Figure 8.105: Monthly average emission levels for continuously monitored Hg emissions to air from reference lines incinerating predominantly HW

8.8 Emission levels achieved by the waste incineration plants reporting periodically monitored emissions in the 2016 data collection: detailed graphs

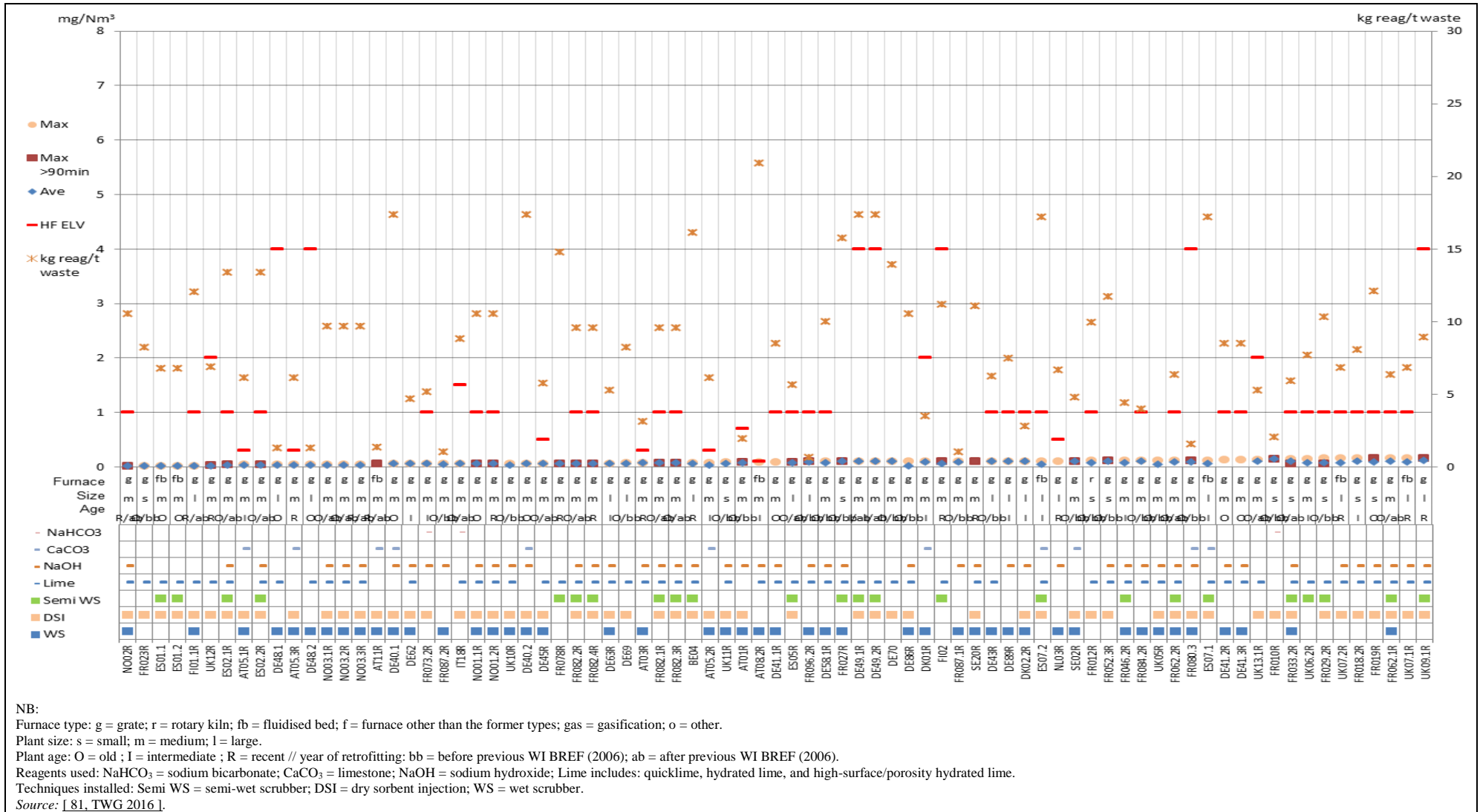

Figure 8.106: Emission levels for periodically monitored HF emissions to air from reference lines incinerating predominantly MSW (1/2)

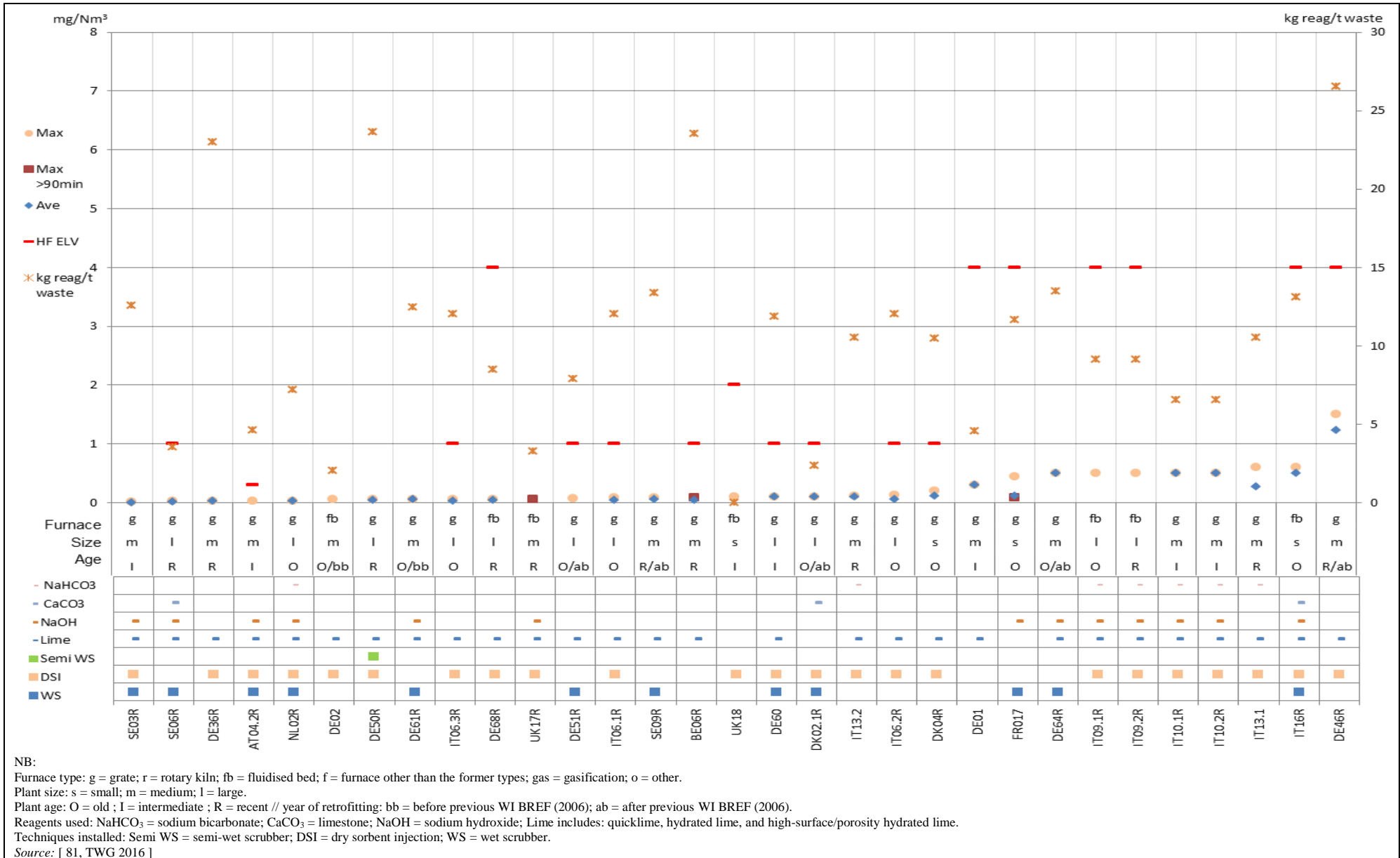

Figure 8.108: Emission levels for periodically monitored HF emissions to air from reference lines incinerating predominantly ONHW

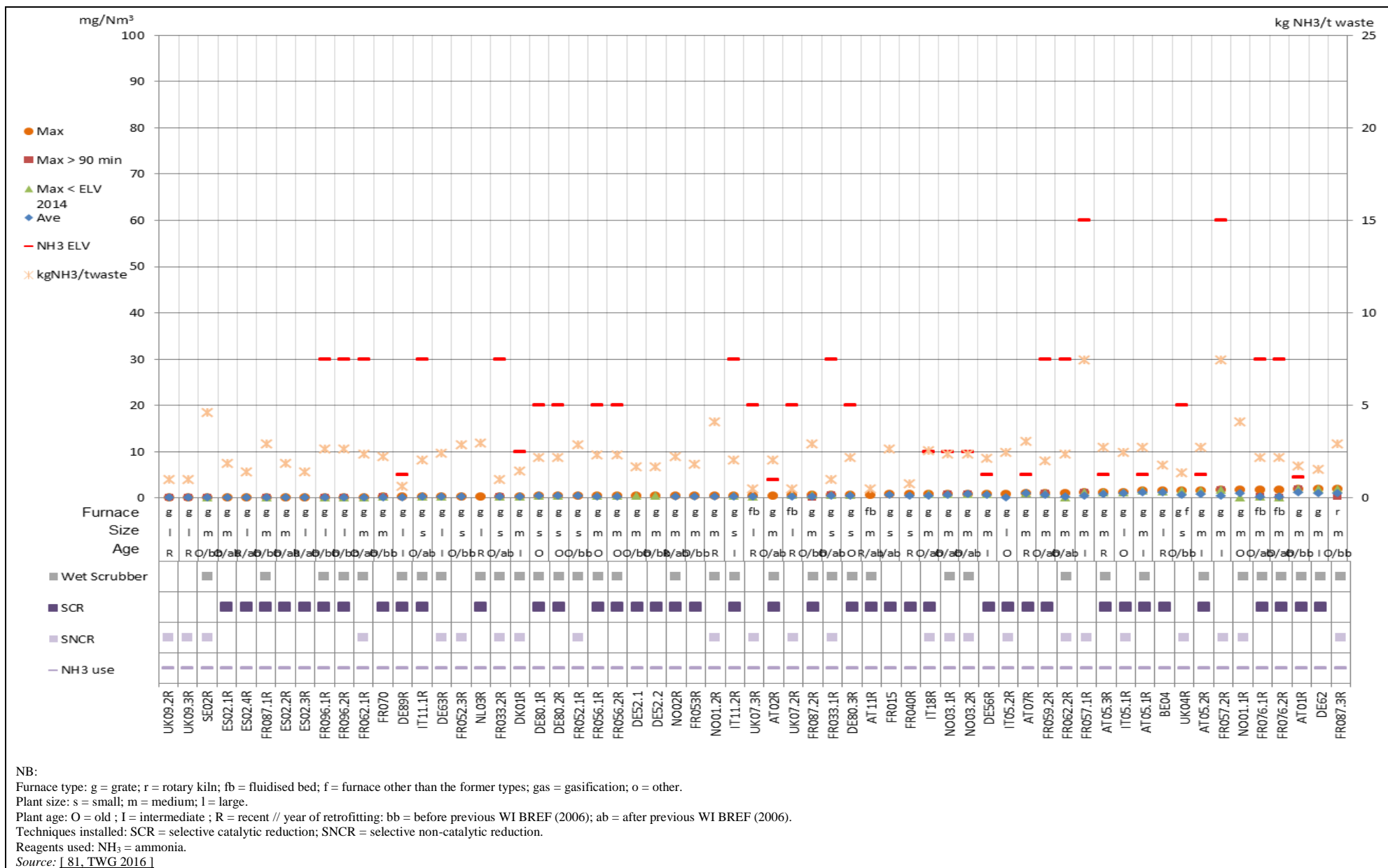

Figure 8.109: Emission levels for periodically monitored NH₃ emissions to air from reference lines incinerating predominantly MSW (1/2)

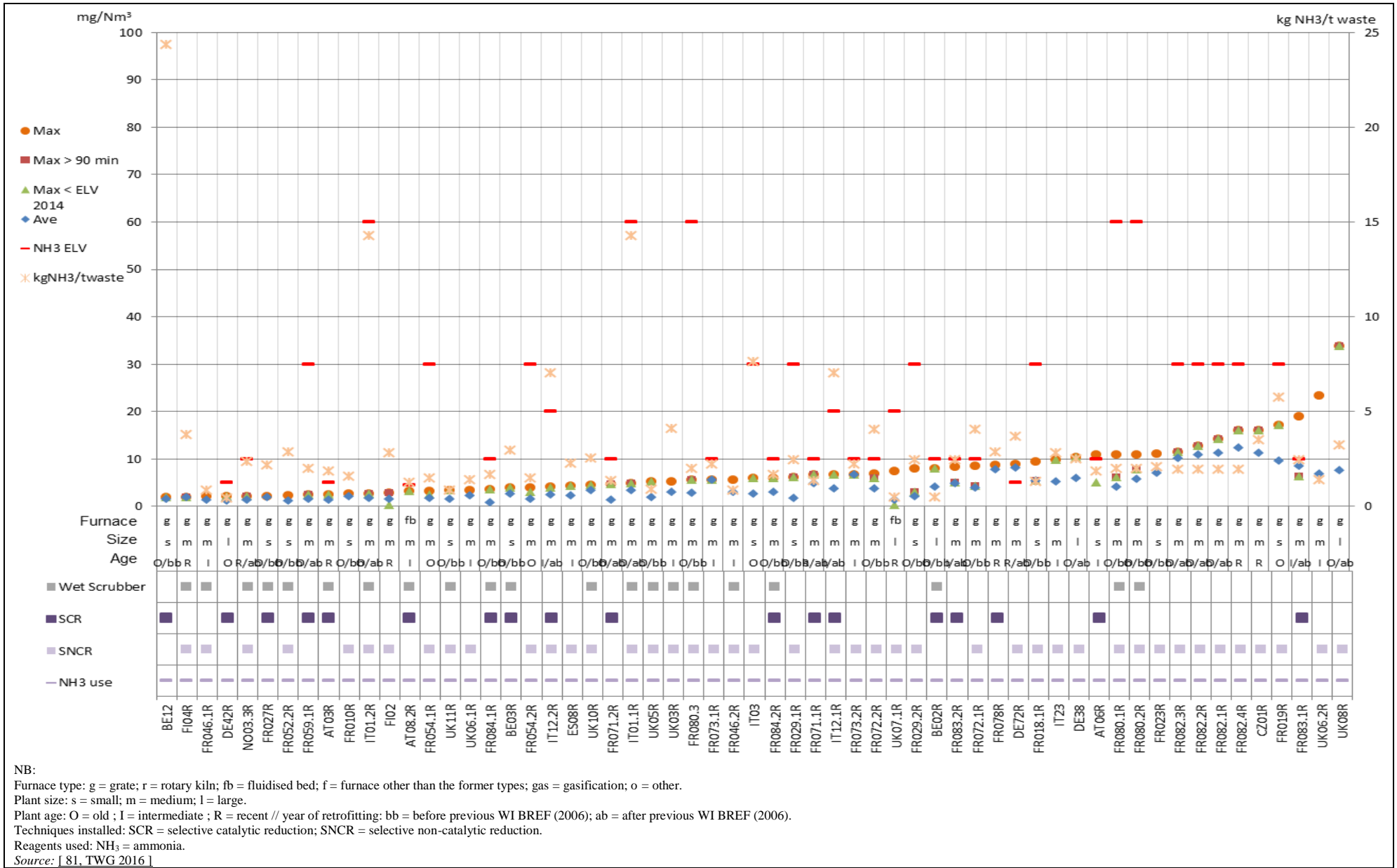

Figure 8.110: Emission levels for periodically monitored NH₃ emissions to air from reference lines incinerating predominantly MSW (2/2)

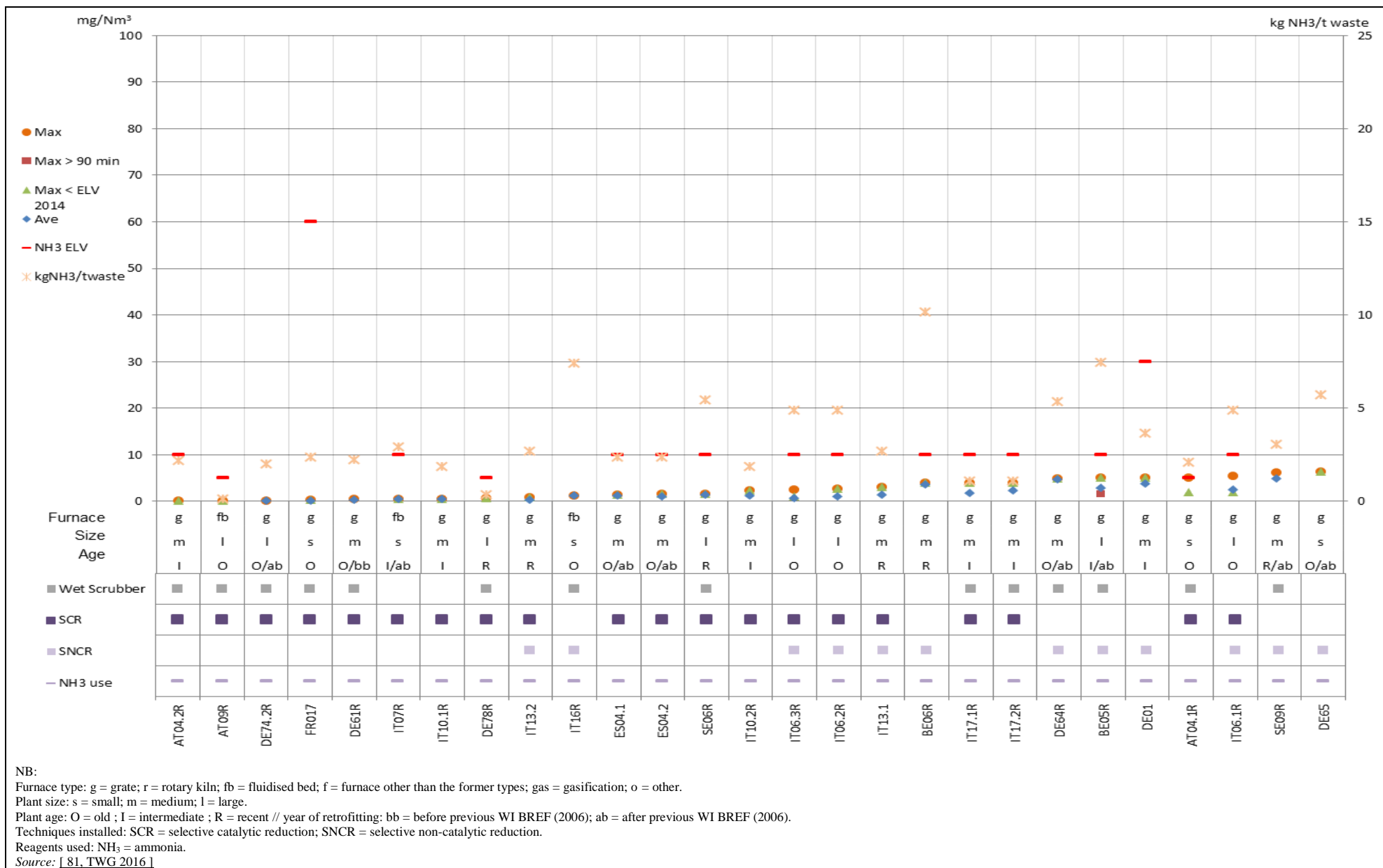

Figure 8.111: Emission levels for periodically monitored NH₃ emissions to air from reference lines incinerating predominantly ONHW

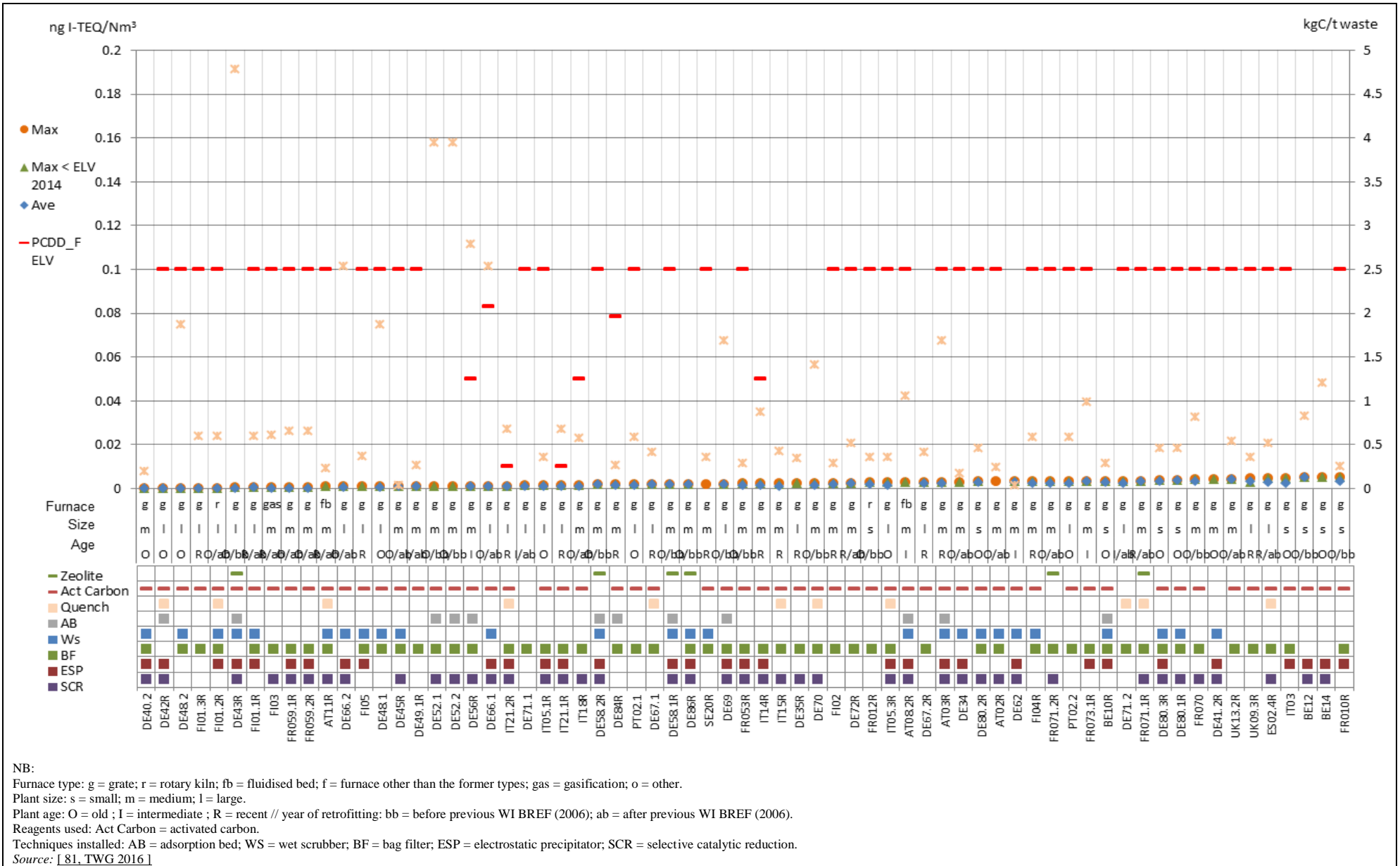

Figure 8.112: Emission levels for periodically monitored PCDD/F emissions to air from reference lines incinerating predominantly MSW (1/3)

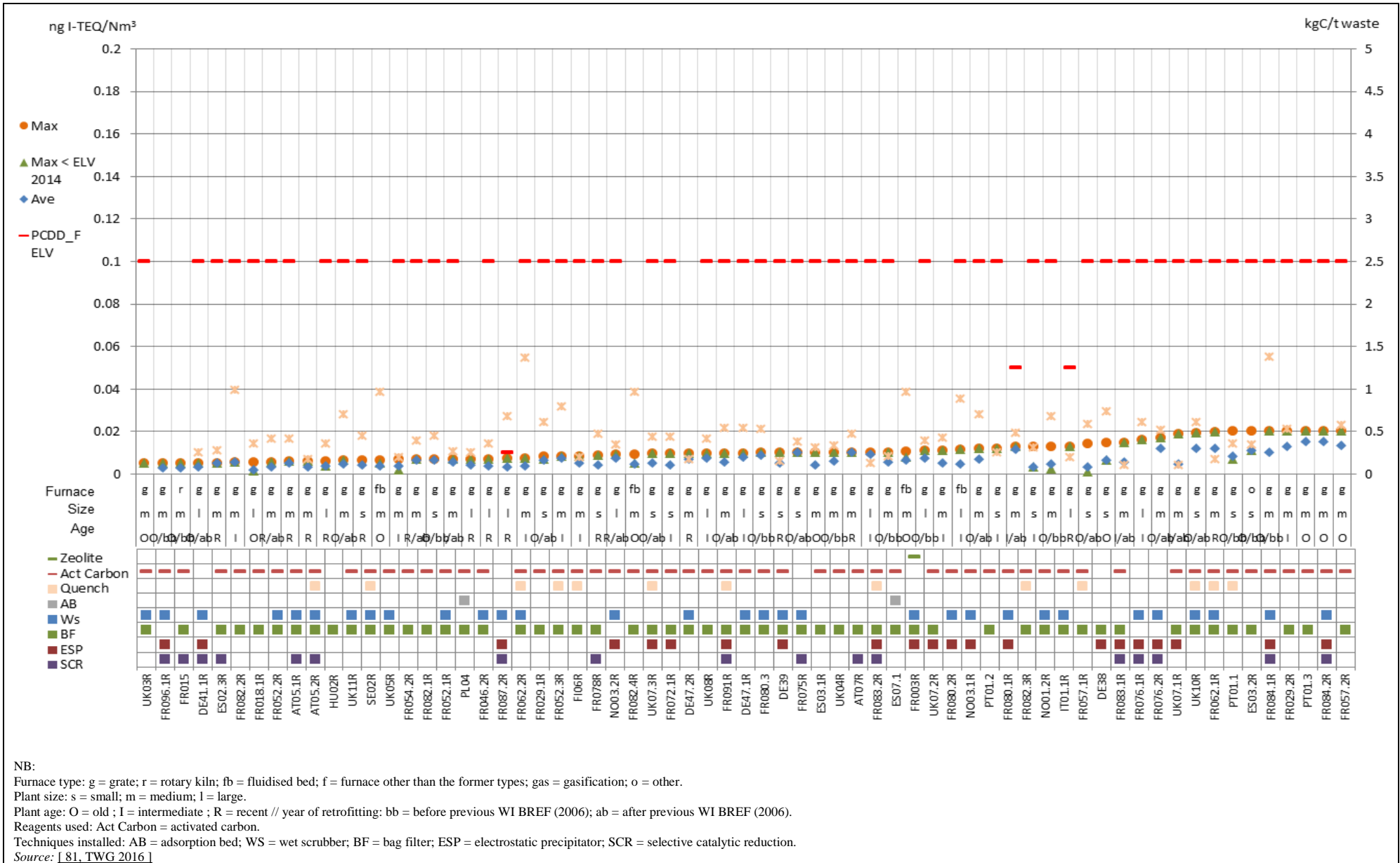

Figure 8.114: Emission levels for periodically monitored PCDD/F emissions to air from reference lines incinerating predominantly MSW (3/3)

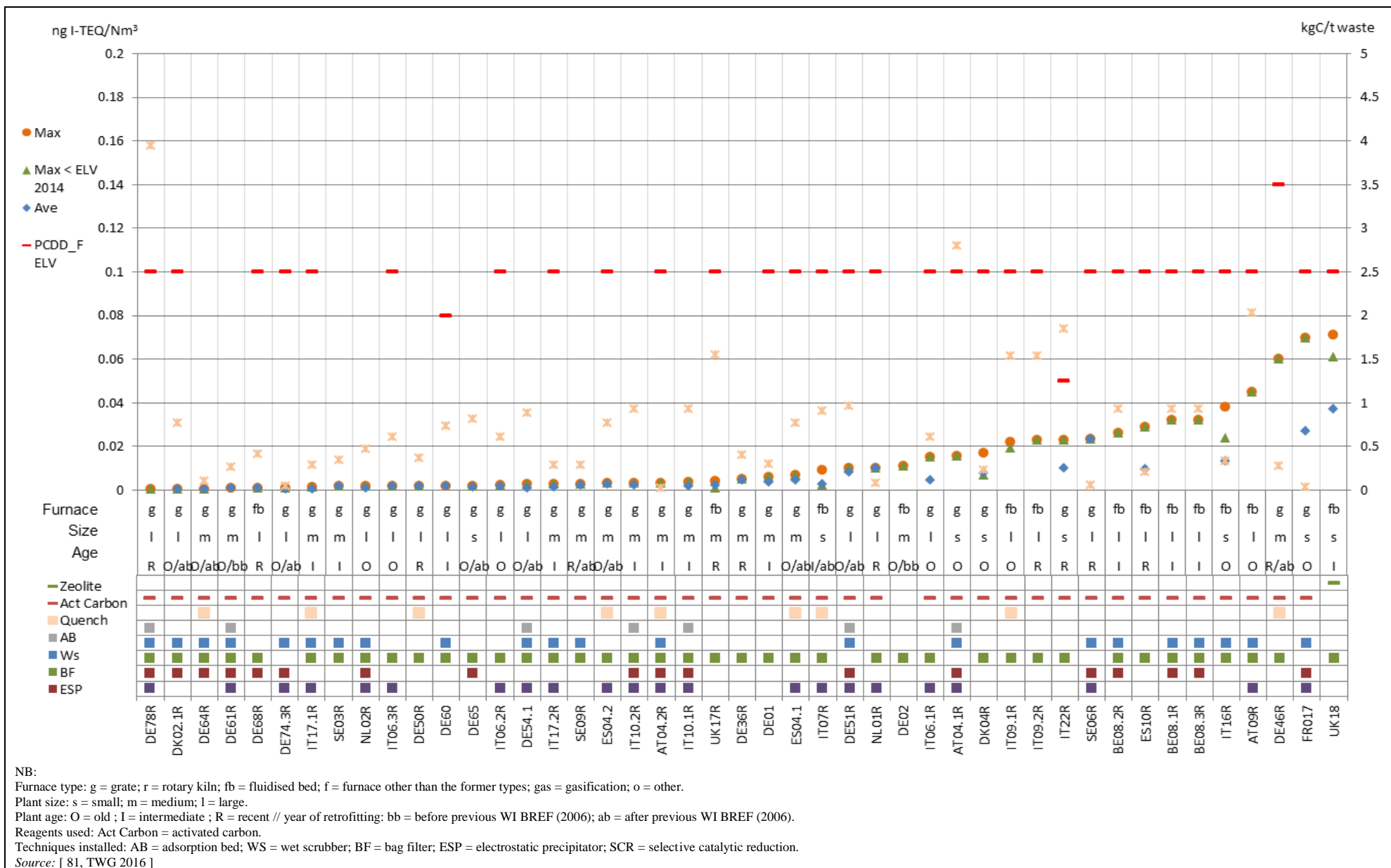

Figure 8.115: Emission levels for periodically monitored PCDD/F emissions to air from reference lines incinerating predominantly ONHW

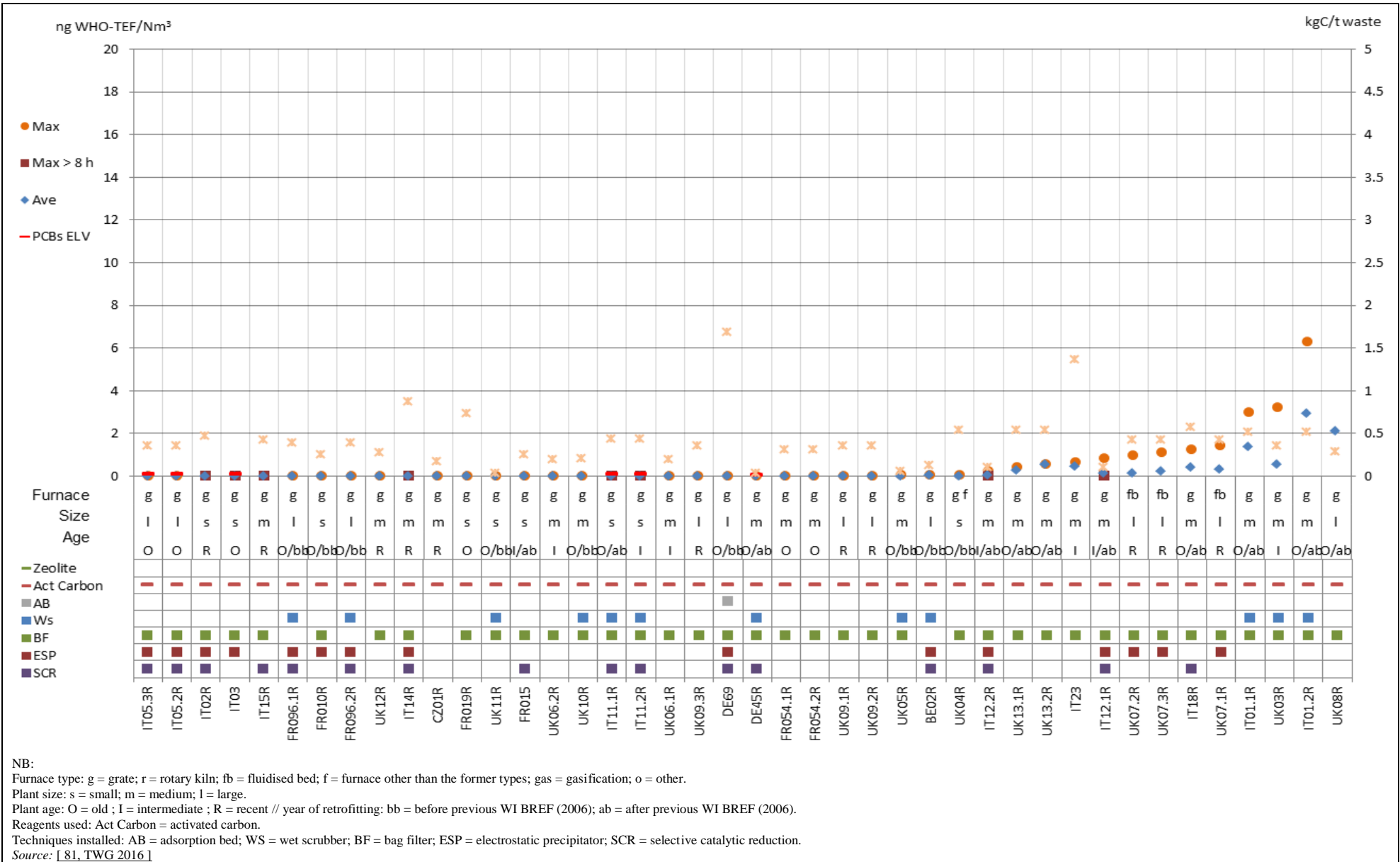

Figure 8.116: Emission levels for periodically monitored dioxin-like PCB emissions to air from reference lines incinerating predominantly MSW

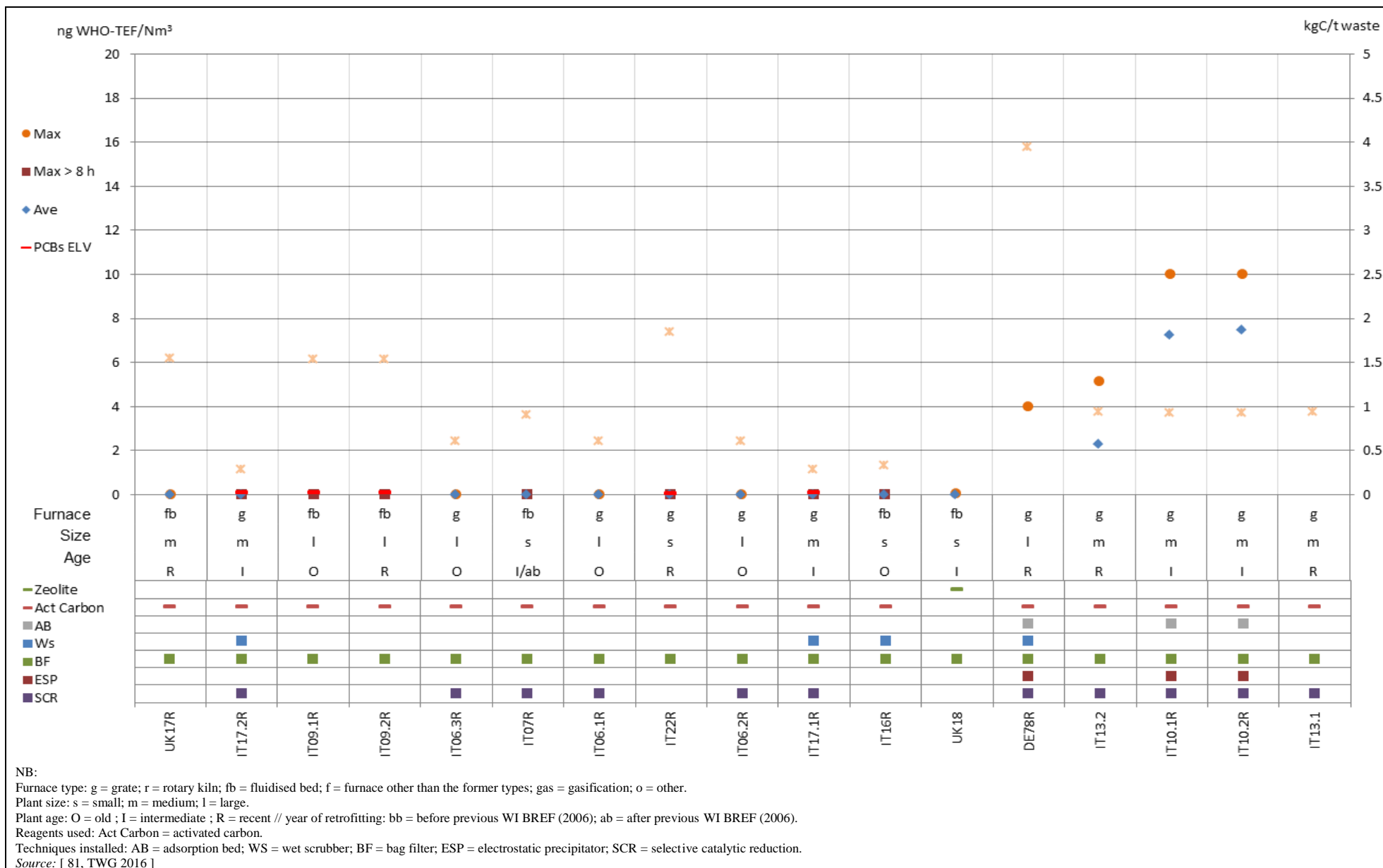

Figure 8.117: Emission levels for periodically monitored dioxin-like PCB emissions to air from reference lines incinerating predominantly ONHW

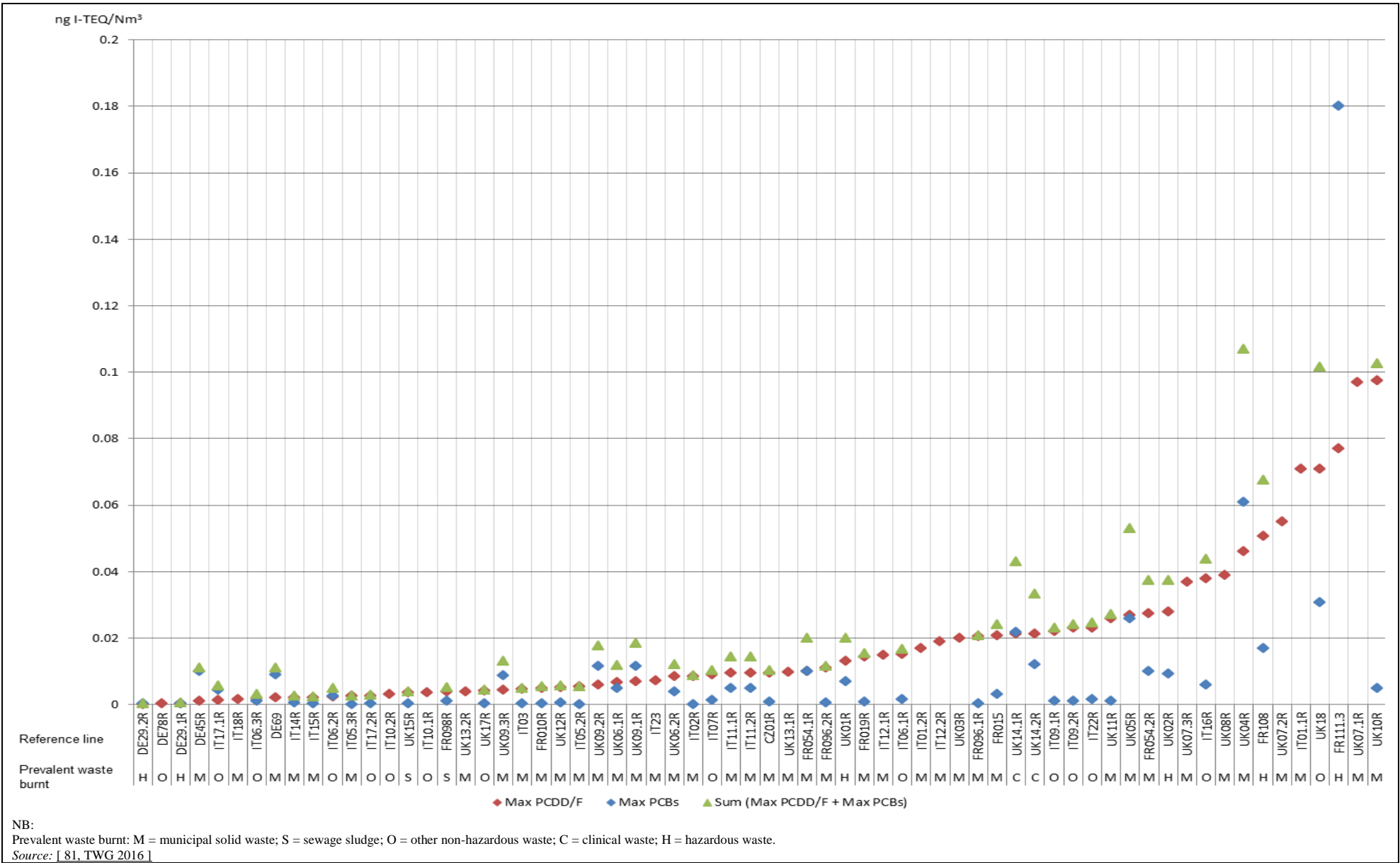

Figure 8.118: Comparative emission levels for emissions to air of PCDD/F and of dioxin-like PCBs measured in the same sample

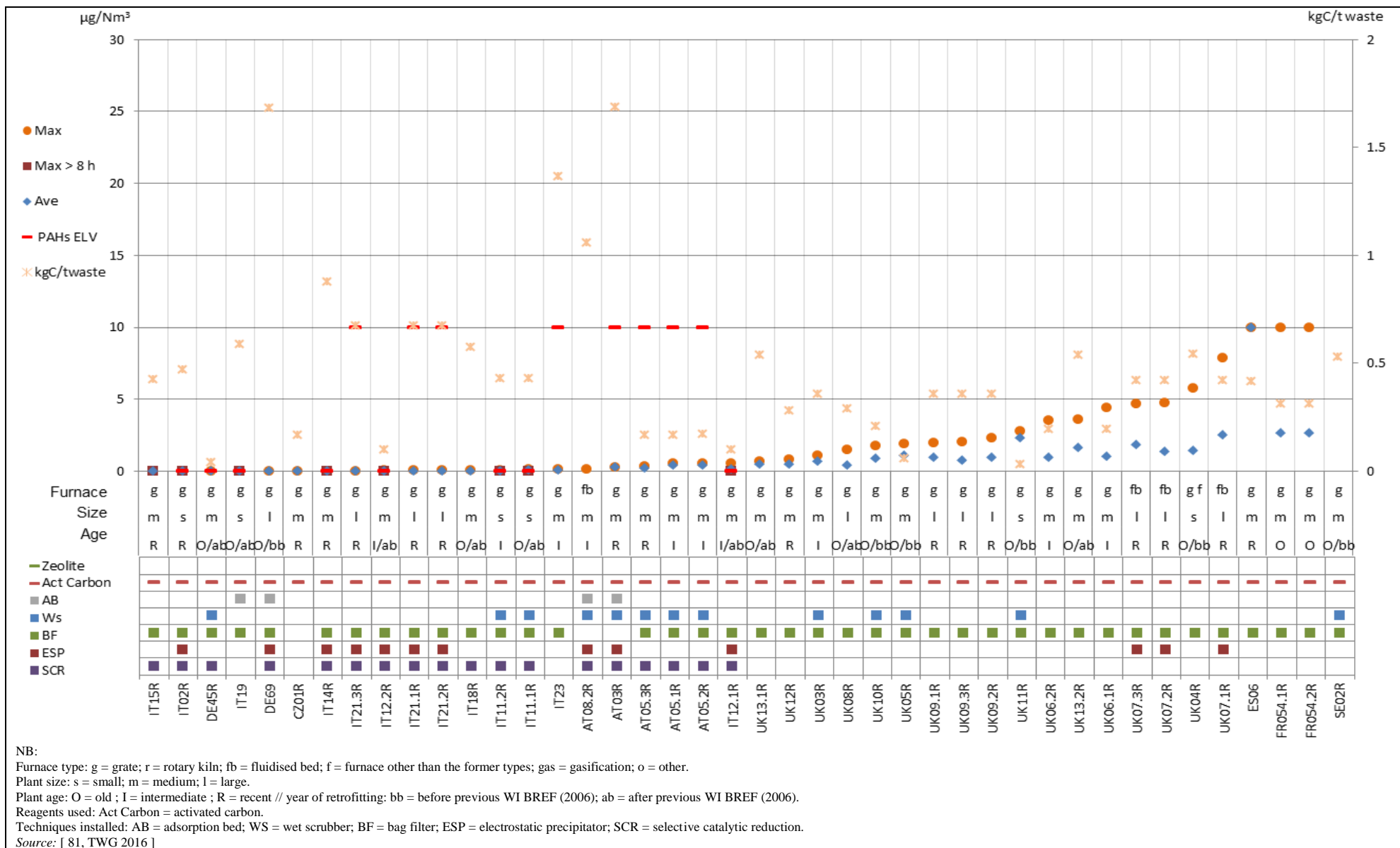

Figure 8.119: Emission levels for periodically monitored PAH emissions to air from reference lines incinerating predominantly MSW

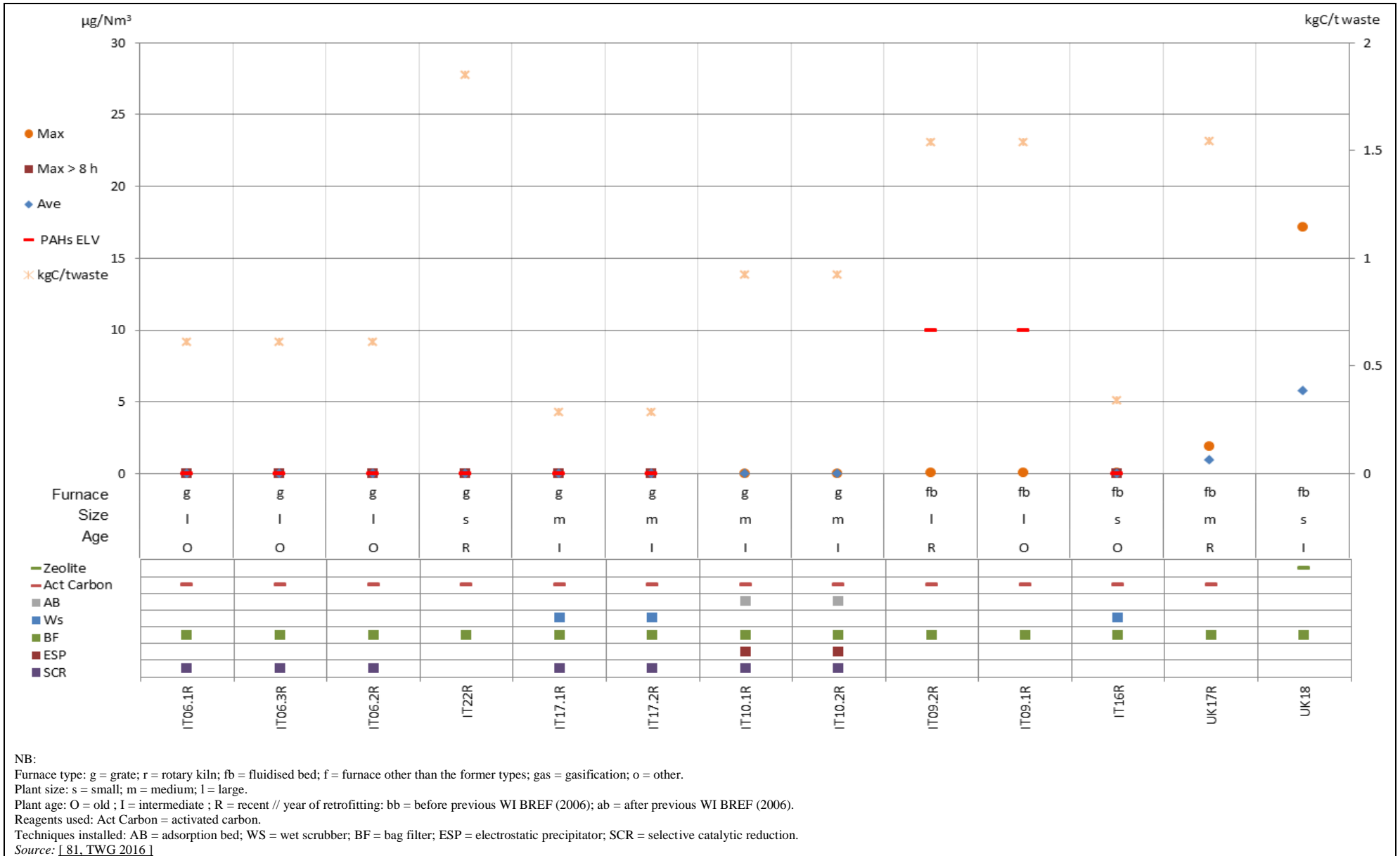
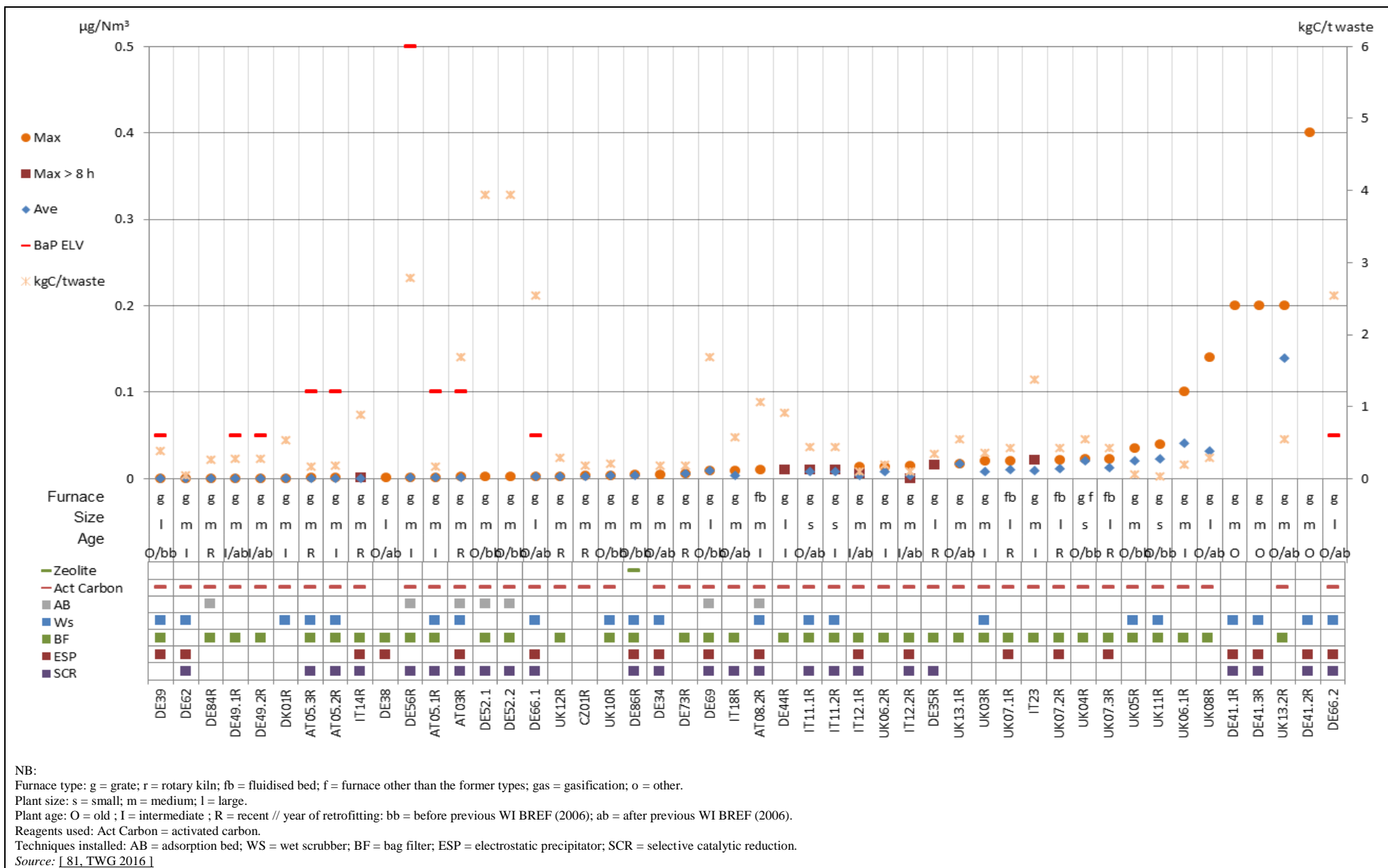

Figure 8.120: Emission levels for periodically monitored PAH emissions to air from reference lines incinerating predominantly ONHW



NB:
 Furnace type: g = grate; r = rotary kiln; fb = fluidised bed; f = furnace other than the former types; gas = gasification; o = other.
 Plant size: s = small; m = medium; l = large.
 Plant age: O = old; I = intermediate; R = recent // year of retrofitting; bb = before previous WI BREF (2006); ab = after previous WI BREF (2006).
 Reagents used: Act Carbon = activated carbon.
 Techniques installed: AB = adsorption bed; WS = wet scrubber; BF = bag filter; ESP = electrostatic precipitator; SCR = selective catalytic reduction.
 Source: [81, TWG 2016]

Figure 8.121: Emission levels for periodically monitored BaP emissions to air from reference lines incinerating predominantly MSW

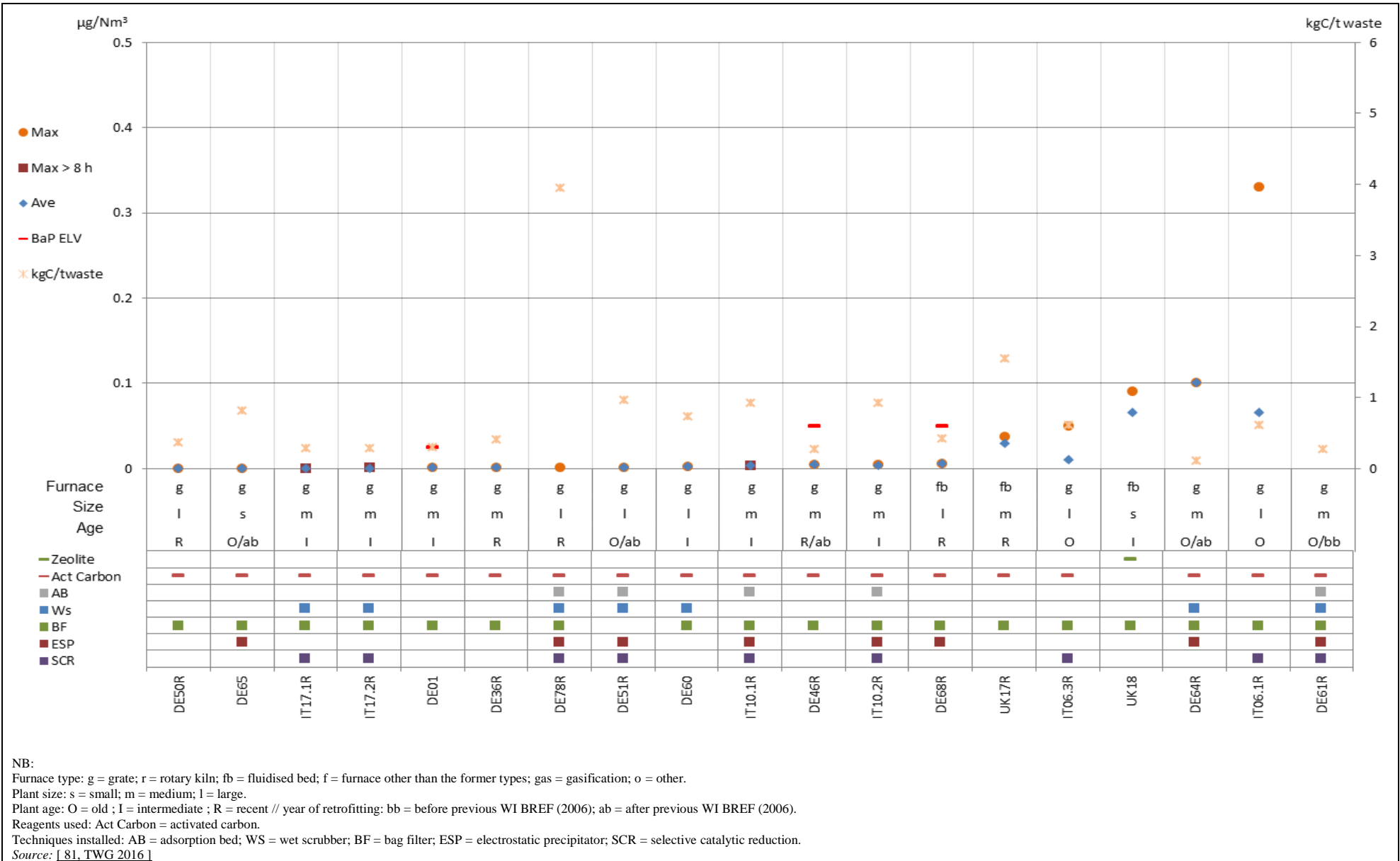

Figure 8.122: Emission levels for periodically monitored BaP emissions to air from reference lines incinerating predominantly ONHW

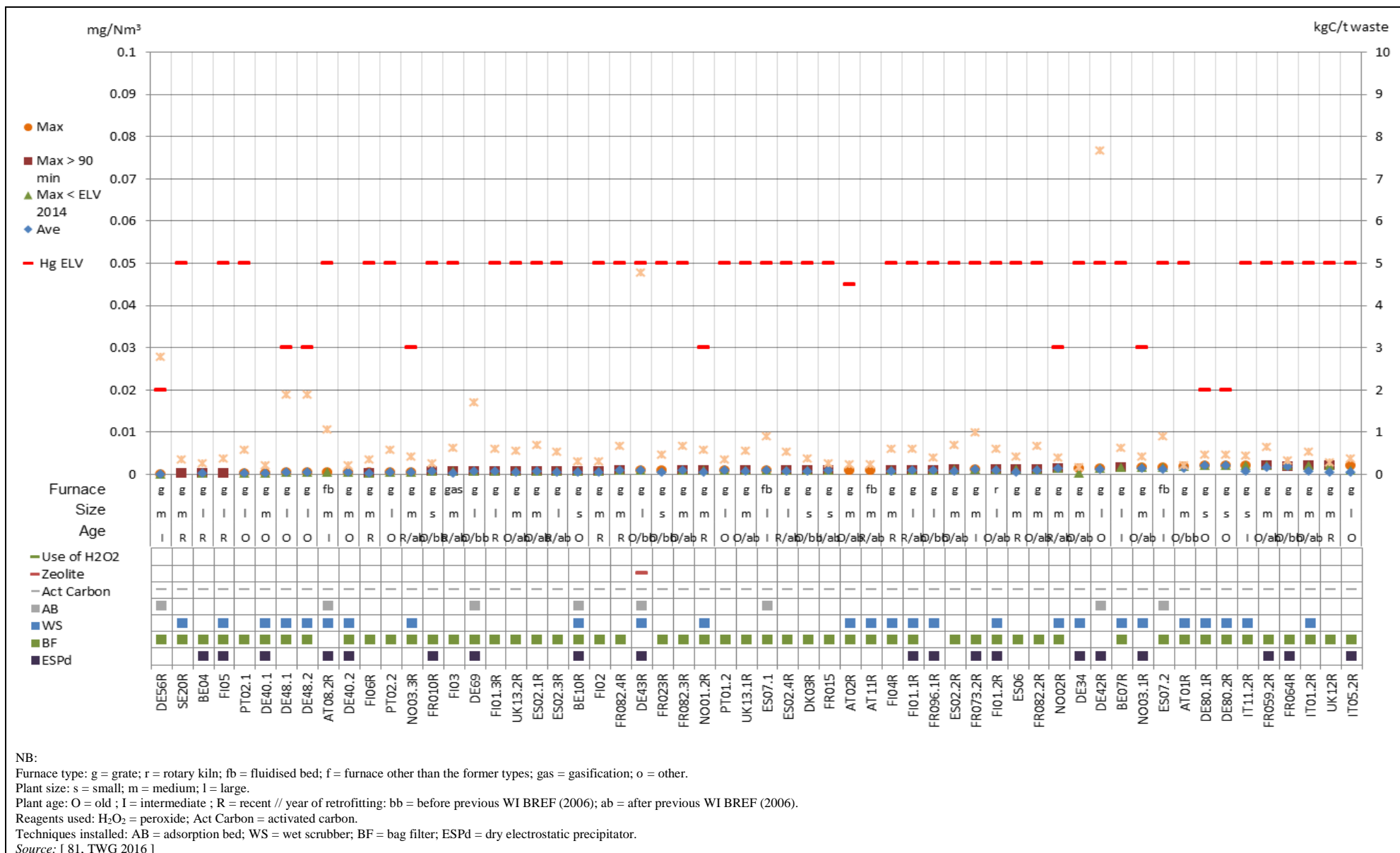

Figure 8.123: Emission levels for periodically monitored Hg emissions to air from reference lines incinerating predominantly MSW (1/3)

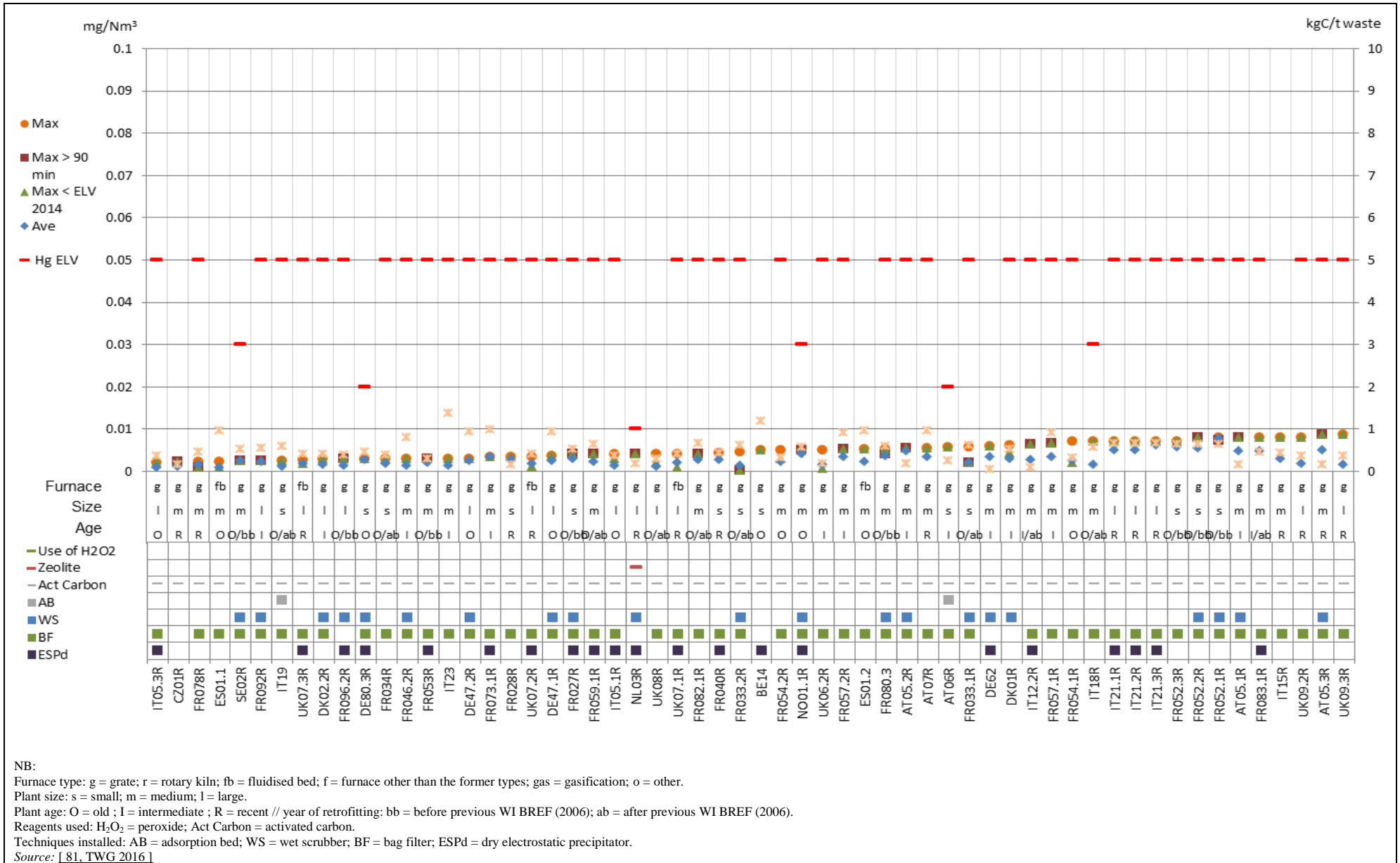

Figure 8.124: Emission levels for periodically monitored Hg emissions to air from reference lines incinerating predominantly MSW (2/3)

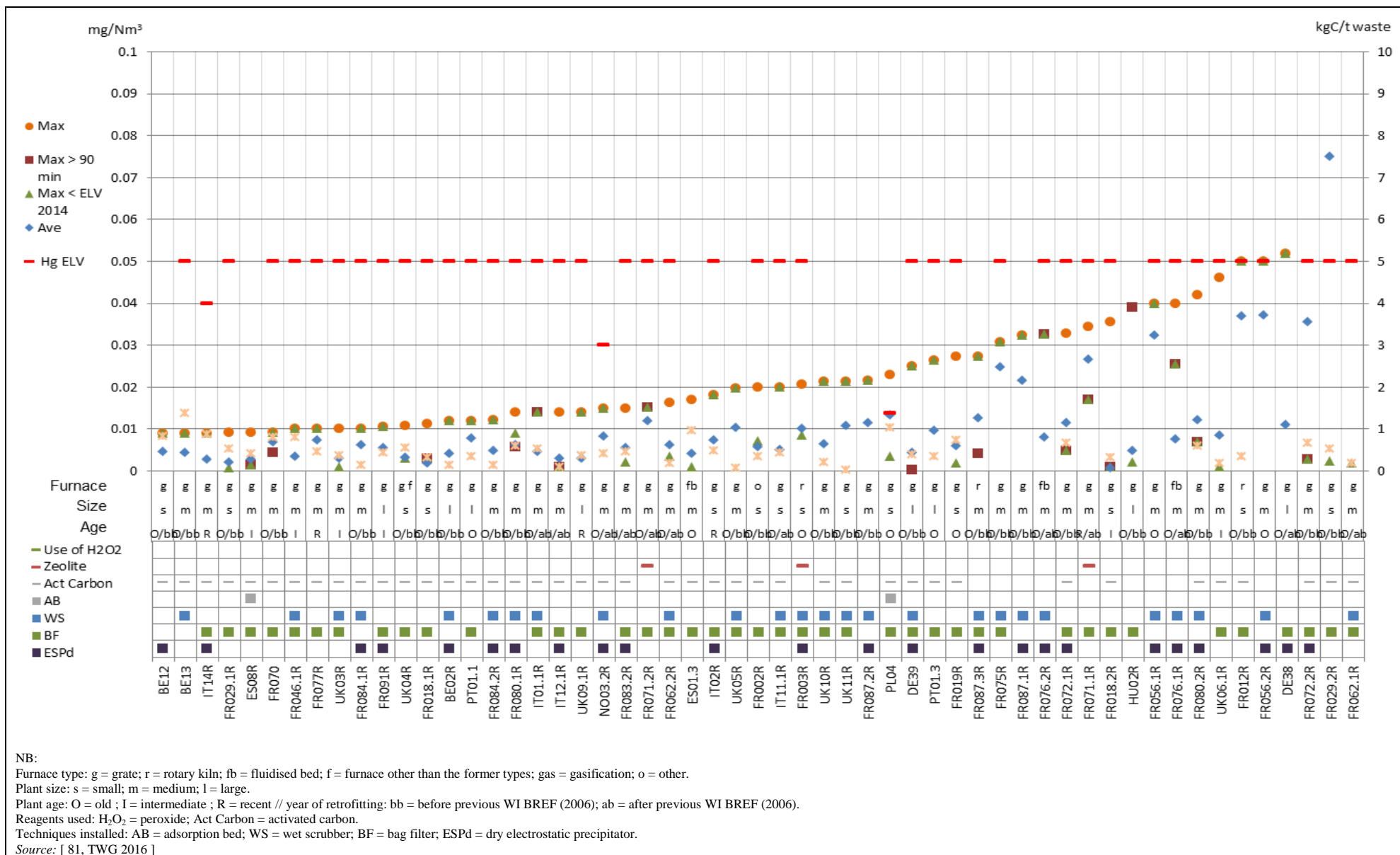

Figure 8.125: Emission levels for periodically monitored Hg emissions to air from reference lines incinerating predominantly MSW (3/3)

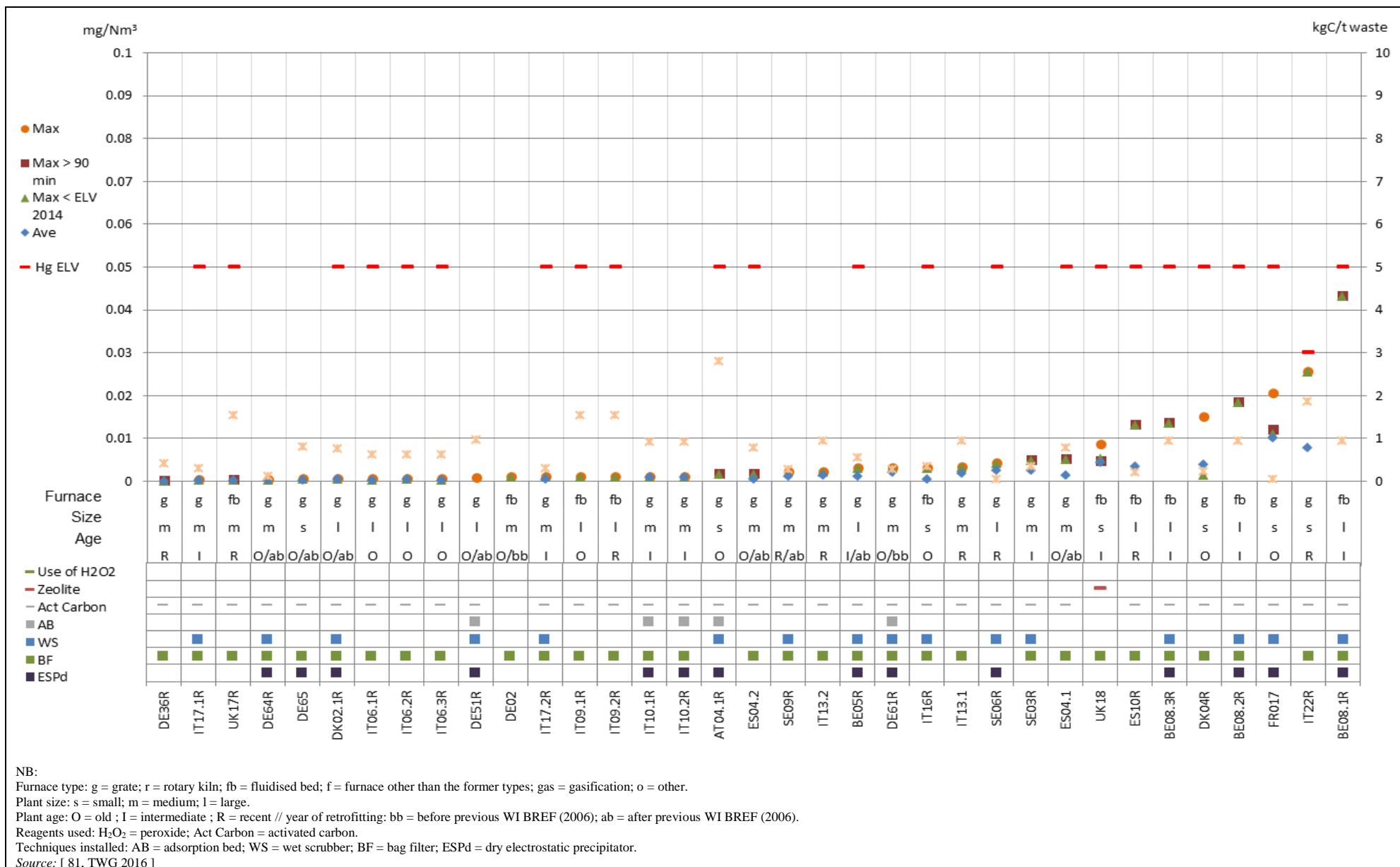

Figure 8.126: Emission levels for periodically monitored Hg emissions to air from reference lines incinerating predominantly ONHW

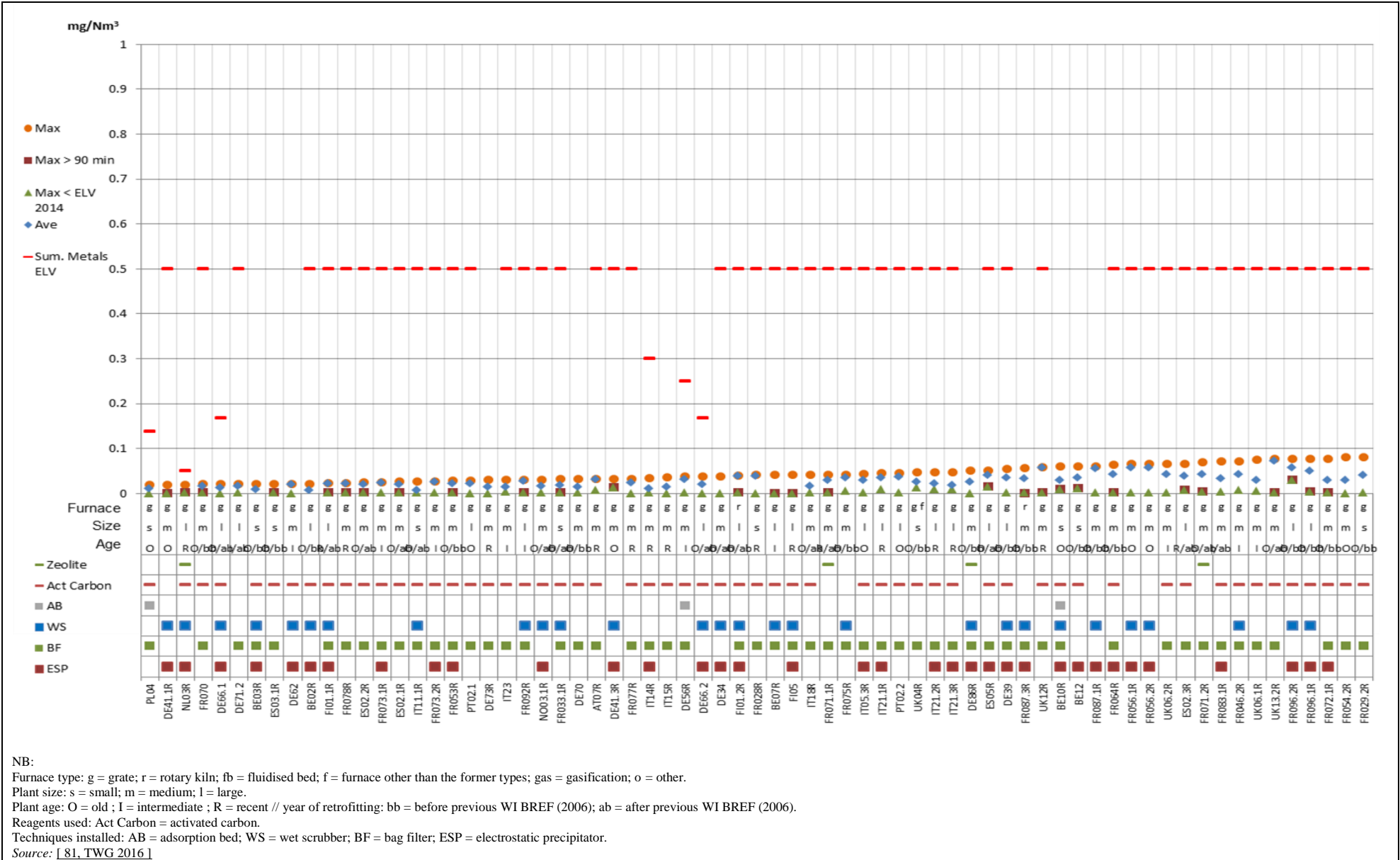

Figure 8.128: Emission levels for periodically monitored Sb+As+Cr+Co+Cu+Pb+Mn+Ni+V emissions to air from reference lines incinerating predominantly MSW (2/3)

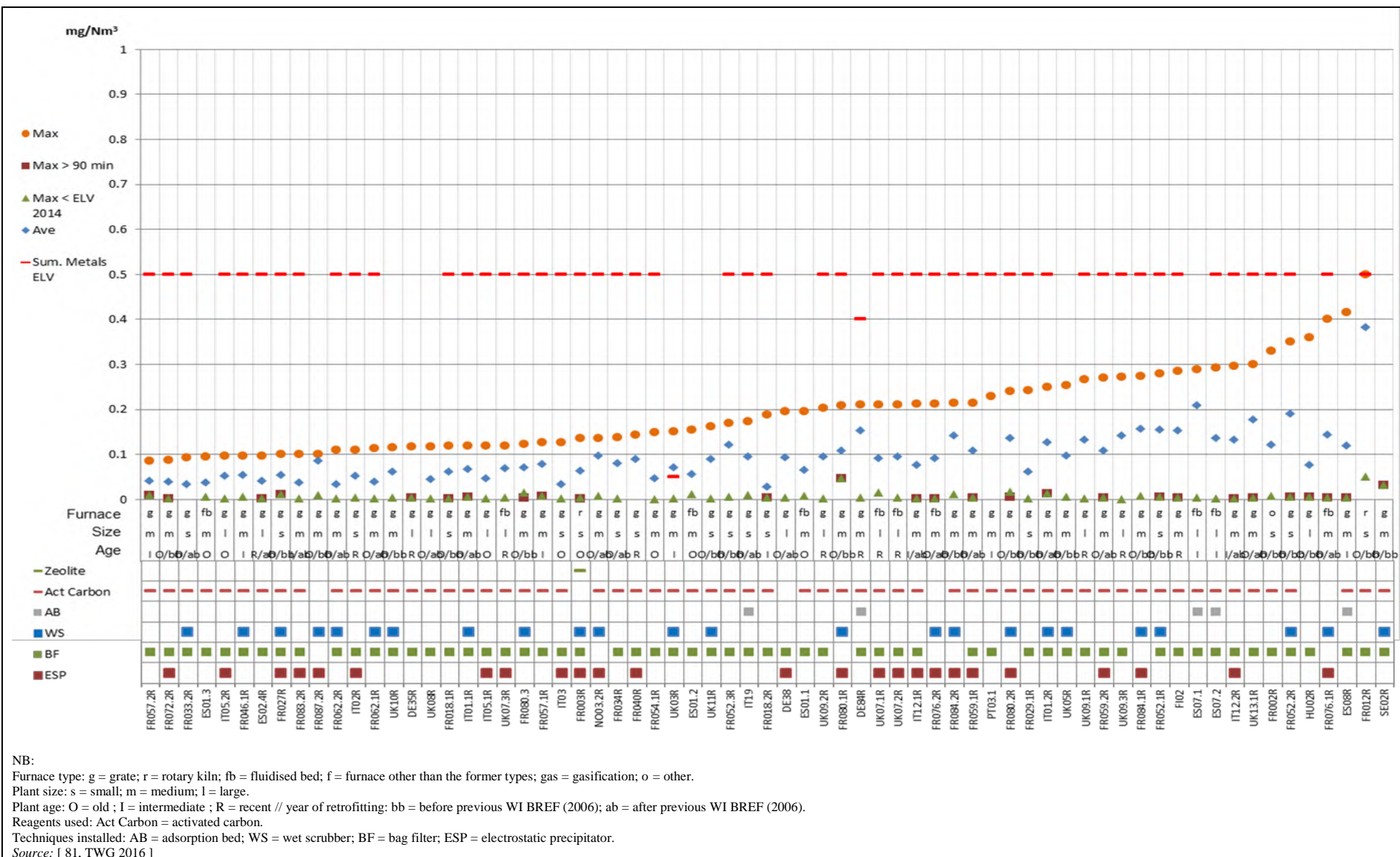

Figure 8.129: Emission levels for periodically monitored Sb+As+Cr+Co+Cu+Pb+Mn+Ni+V emissions to air from reference lines incinerating predominantly MSW (3/3)

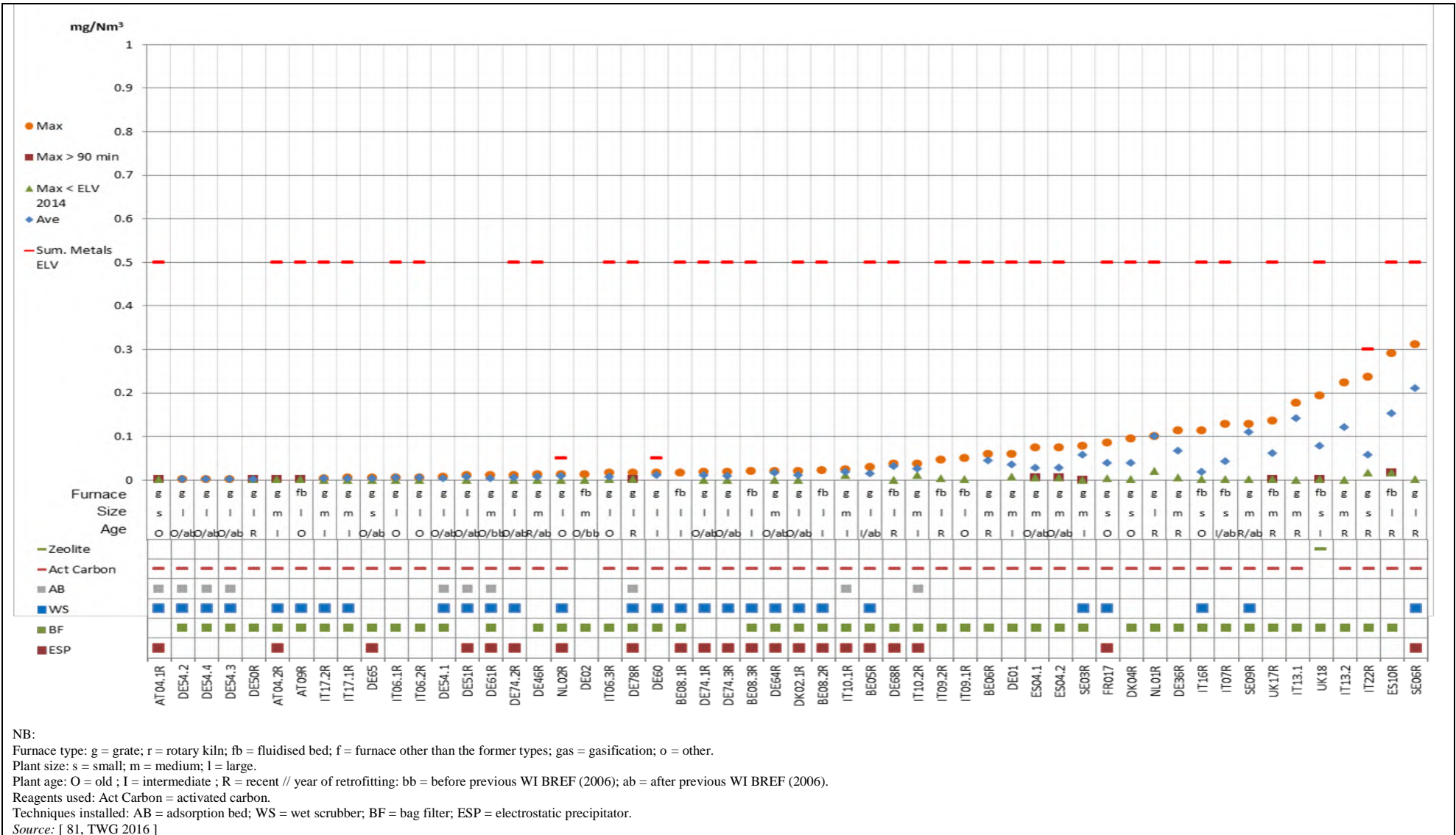
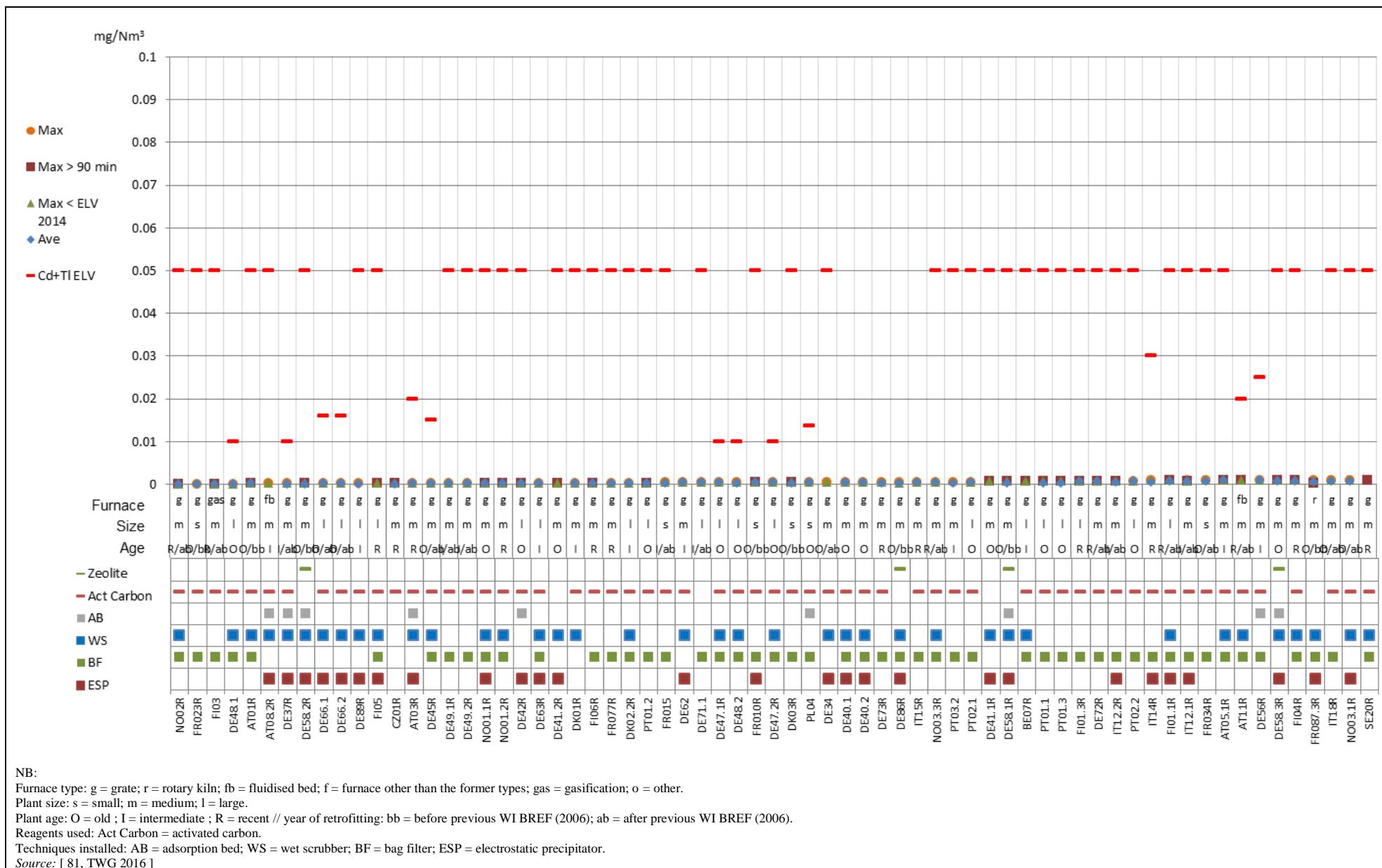
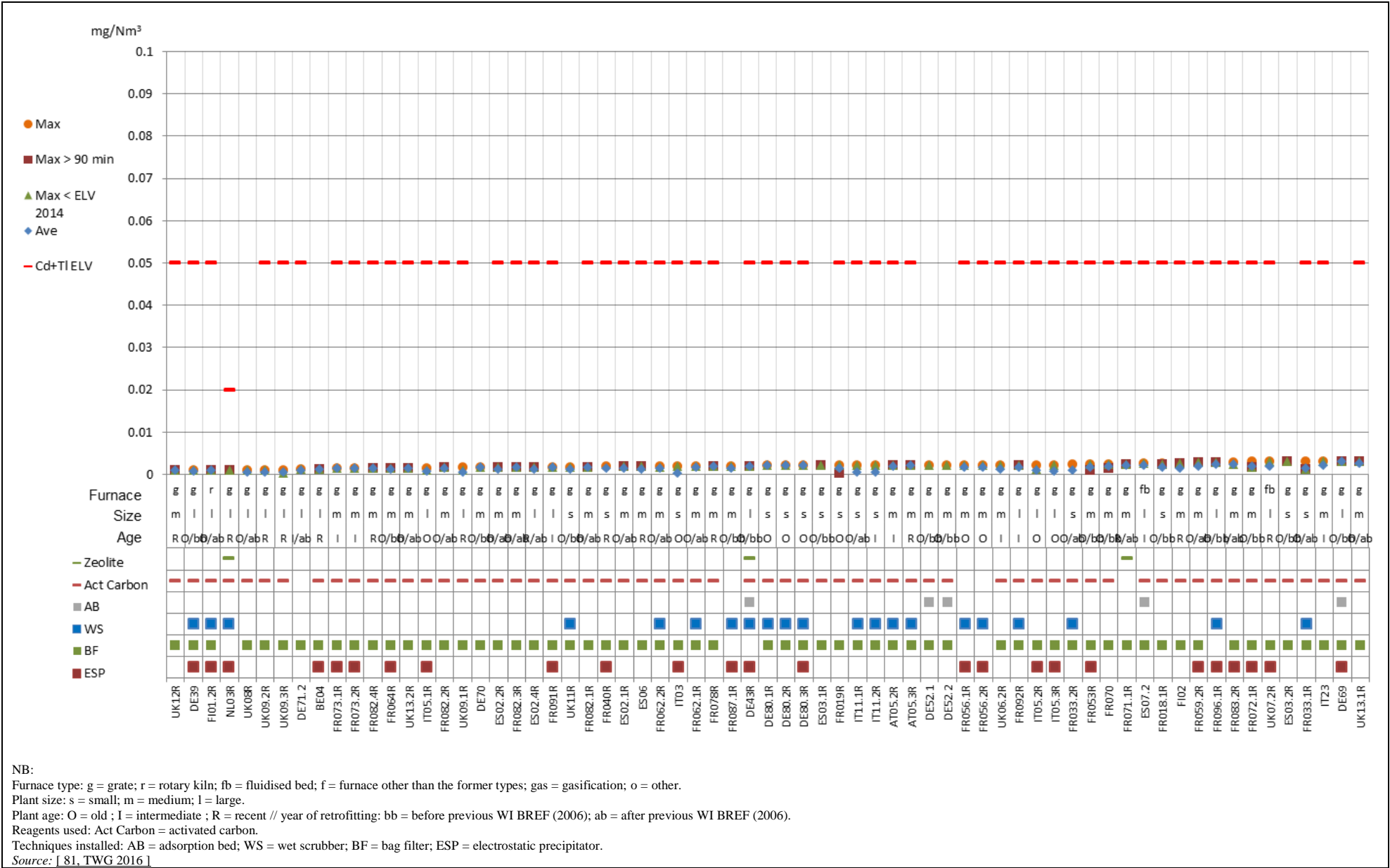

Figure 8.130: Emission levels for periodically monitored Sb+As+Cr+Co+Cu+Pb+Mn+Ni+V emissions to air from reference lines incinerating predominantly ONHW



NB:
 Furnace type: g = grate; r = rotary kiln; fb = fluidised bed; f = furnace other than the former types; gas = gasification; o = other.
 Plant size: s = small; m = medium; l = large.
 Plant age: O = old ; I = intermediate ; R = recent // year of retrofitting: bb = before previous WI BREF (2006); ab = after previous WI BREF (2006).
 Reagents used: Act Carbon = activated carbon.
 Techniques installed: AB = adsorption bed; WS = wet scrubber; BF = bag filter; ESP = electrostatic precipitator.
 Source: [81, TWG 2016]

Figure 8.131: Emission levels for periodically monitored Cd+Tl emissions to air from reference lines incinerating predominantly MSW (1/3)



NB:
 Furnace type: g = grate; r = rotary kiln; fb = fluidised bed; f = furnace other than the former types; gas = gasification; o = other.
 Plant size: s = small; m = medium; l = large.
 Plant age: O = old; I = intermediate; R = recent // year of retrofitting; bb = before previous WI BREF (2006); ab = after previous WI BREF (2006).
 Reagents used: Act Carbon = activated carbon.
 Techniques installed: AB = adsorption bed; WS = wet scrubber; BF = bag filter; ESP = electrostatic precipitator.
 Source: [81, TWG 2016]

Figure 8.132: Emission levels for periodically monitored Cd+Tl emissions to air from reference lines incinerating predominantly MSW (2/3)

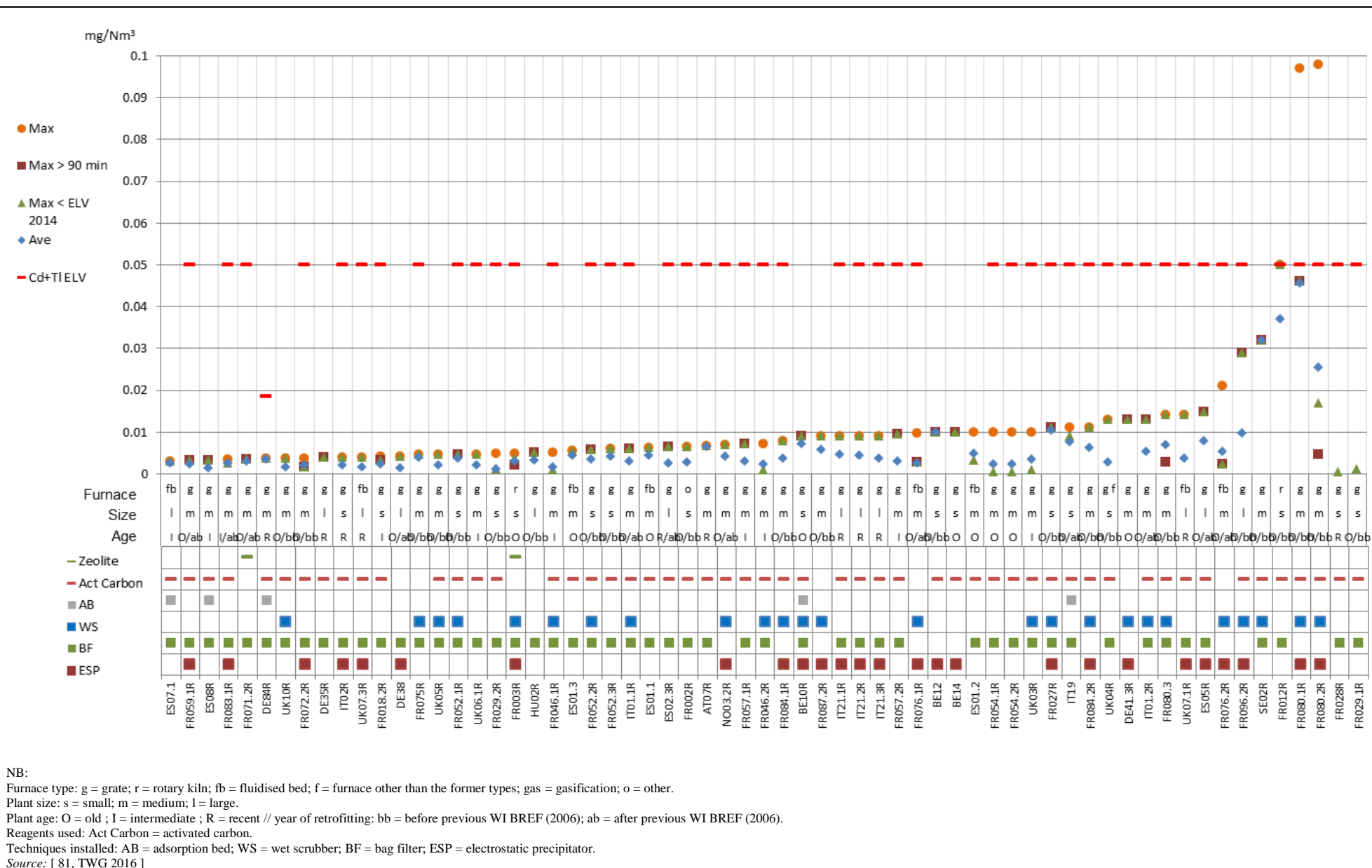

NB:
 Furnace type: g = grate; r = rotary kiln; fb = fluidised bed; f = furnace other than the former types; gas = gasification; o = other.
 Plant size: s = small; m = medium; l = large.
 Plant age: O = old ; I = intermediate ; R = recent // year of retrofitting: bb = before previous WI BREF (2006); ab = after previous WI BREF (2006).
 Reagents used: Act Carbon = activated carbon.
 Techniques installed: AB = adsorption bed; WS = wet scrubber; BF = bag filter; ESP = electrostatic precipitator.
 Source: [81, TWG 2016]

Figure 8.133: Emission levels for periodically monitored Cd+Tl emissions to air from reference lines incinerating predominantly MSW (3/3)

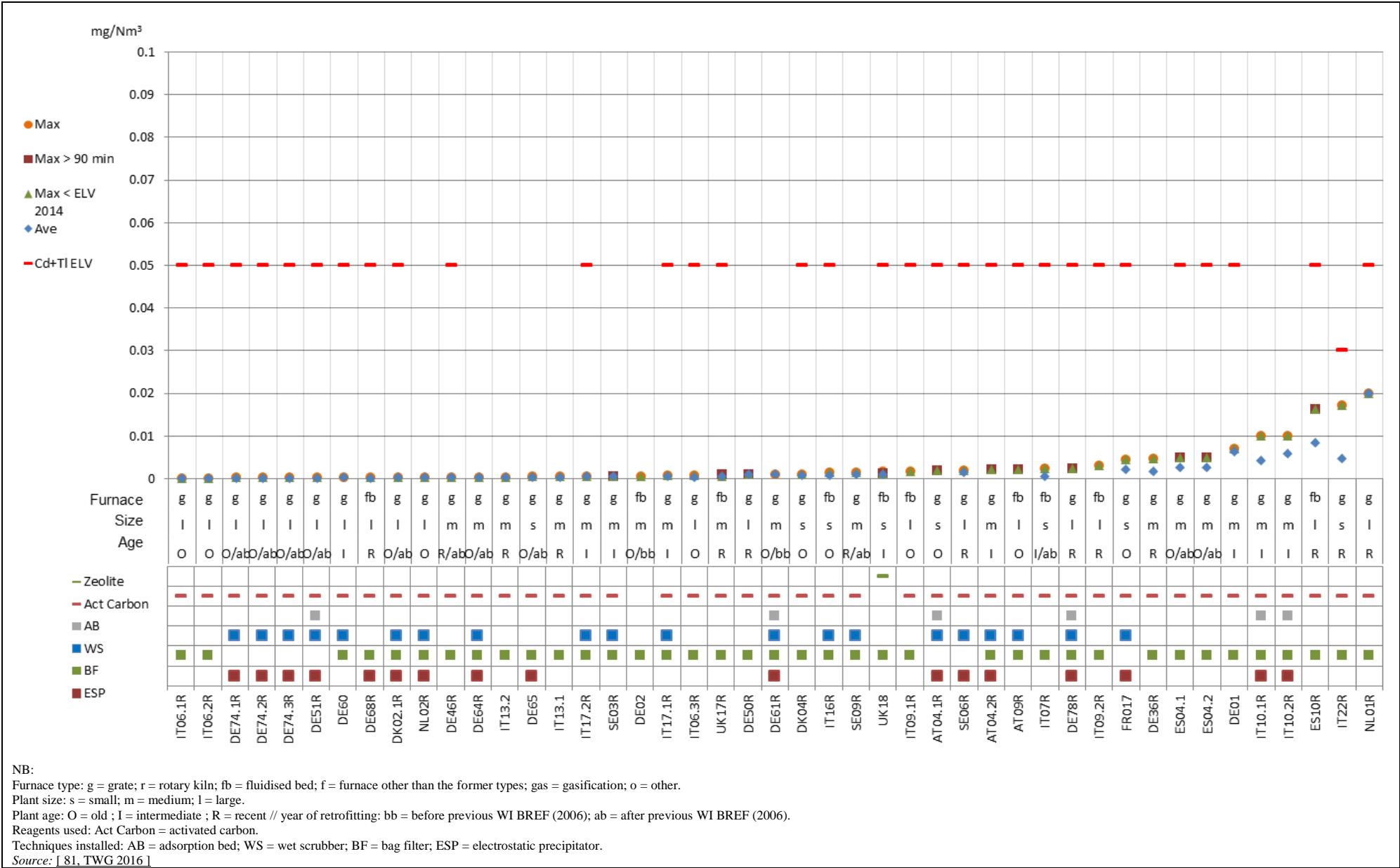

Figure 8.134: Emission levels for periodically monitored Cd+Tl emissions to air from reference lines incinerating predominantly ONHW

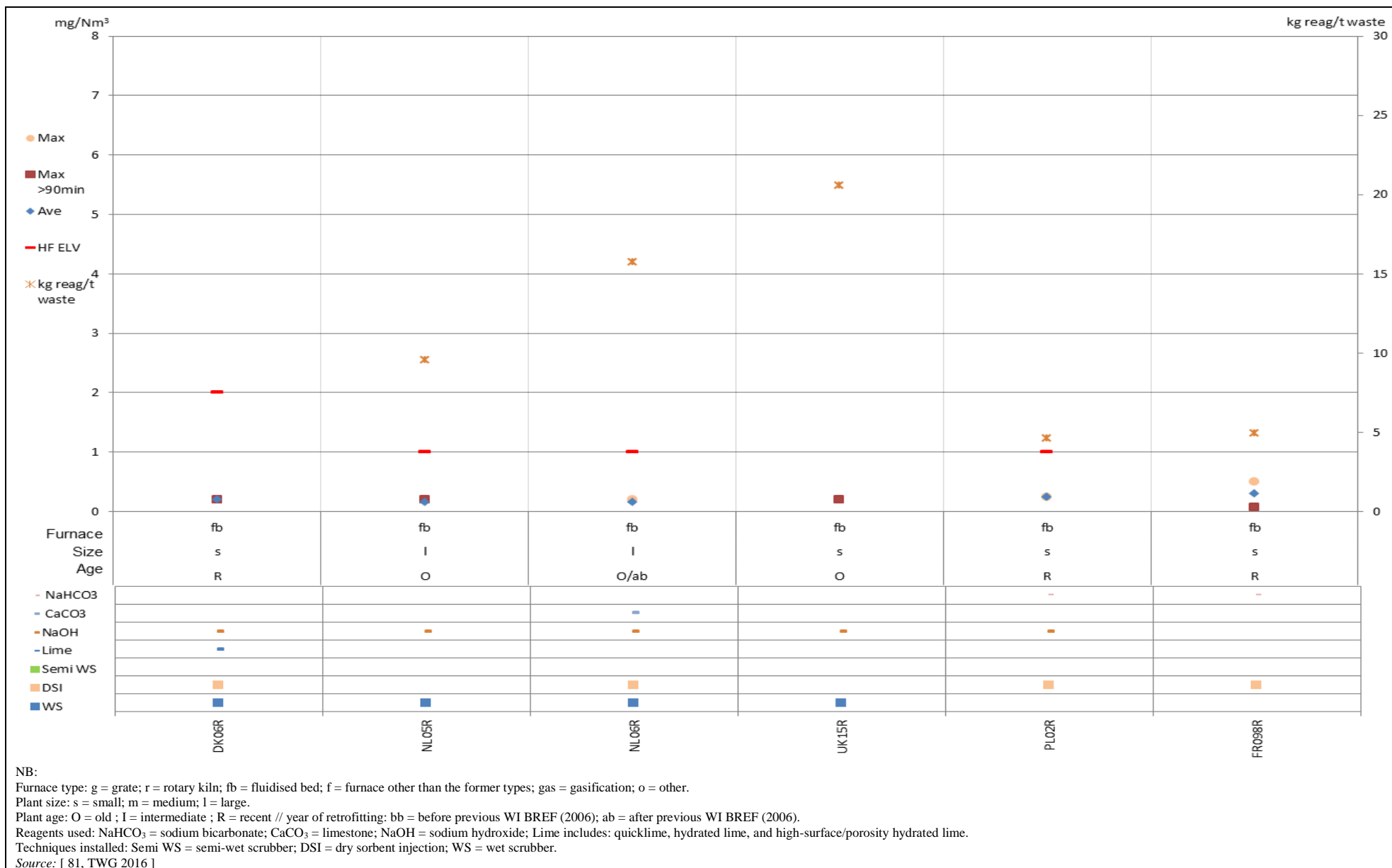

Figure 8.135: Emission levels for periodically monitored HF emissions to air from reference lines incinerating predominantly SS

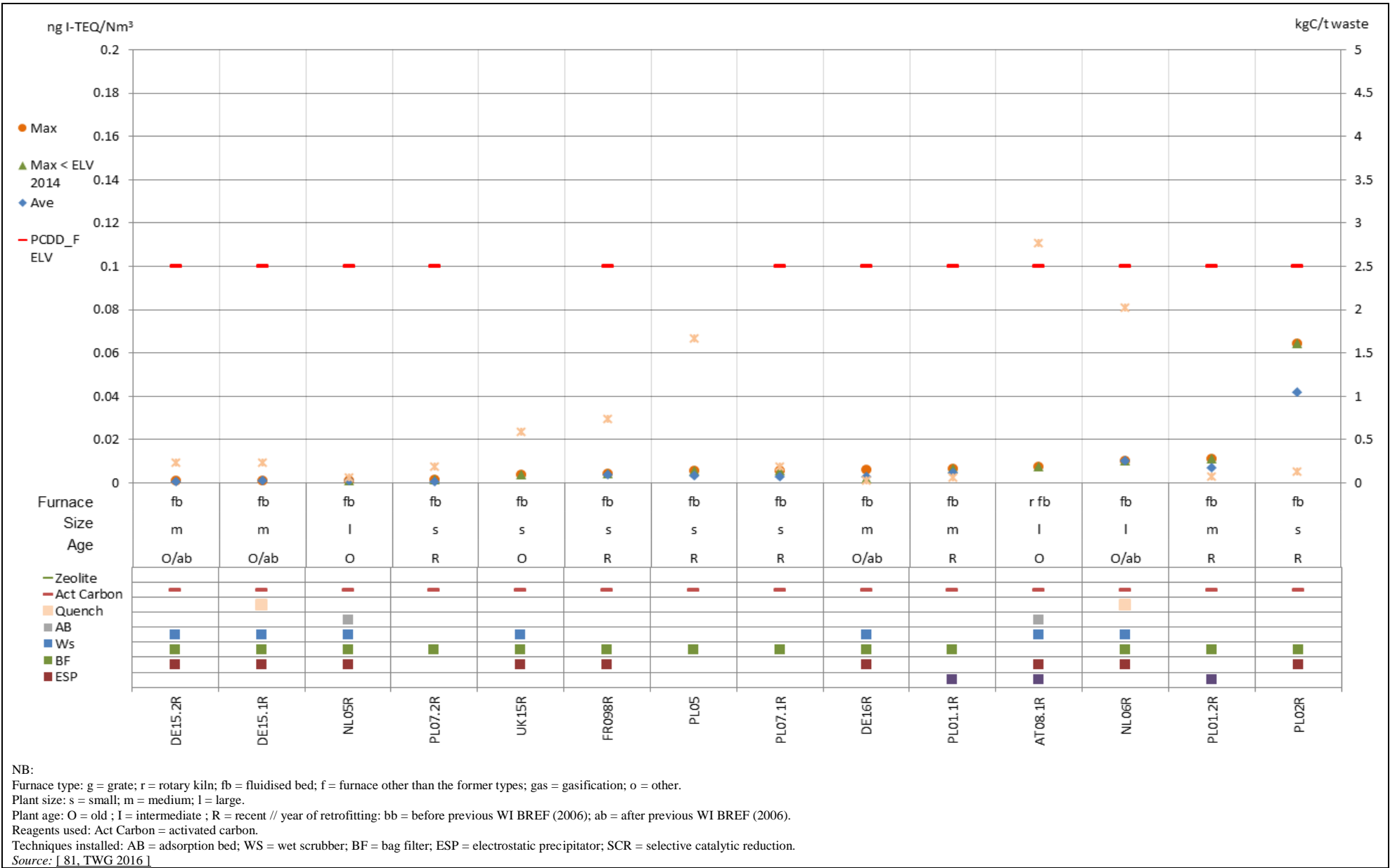

Figure 8.136: Emission levels for periodically monitored PCDD/F emissions to air from reference lines incinerating predominantly SS

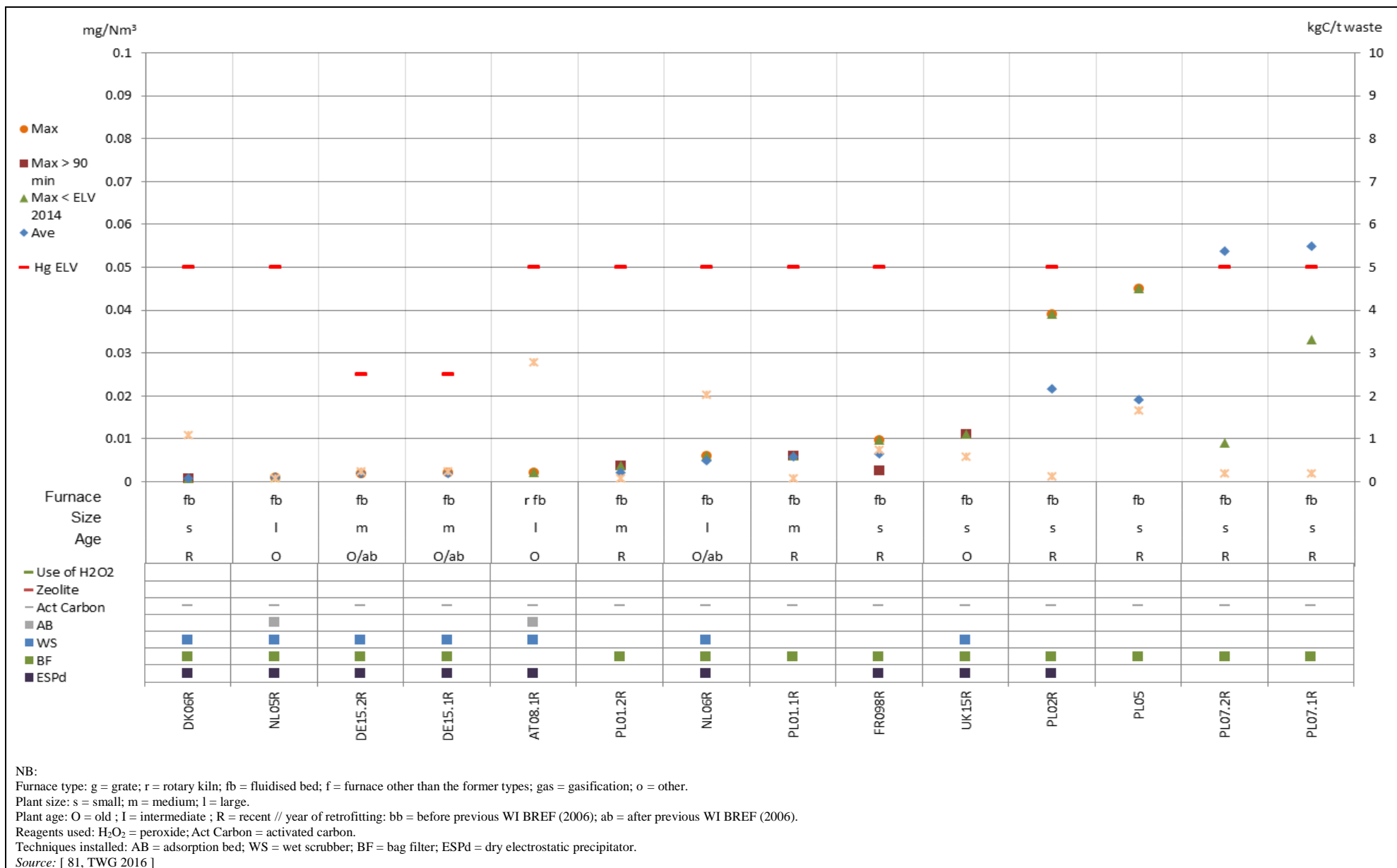

Figure 8.137: Emission levels for periodically monitored Hg emissions to air from reference lines incinerating predominantly SS

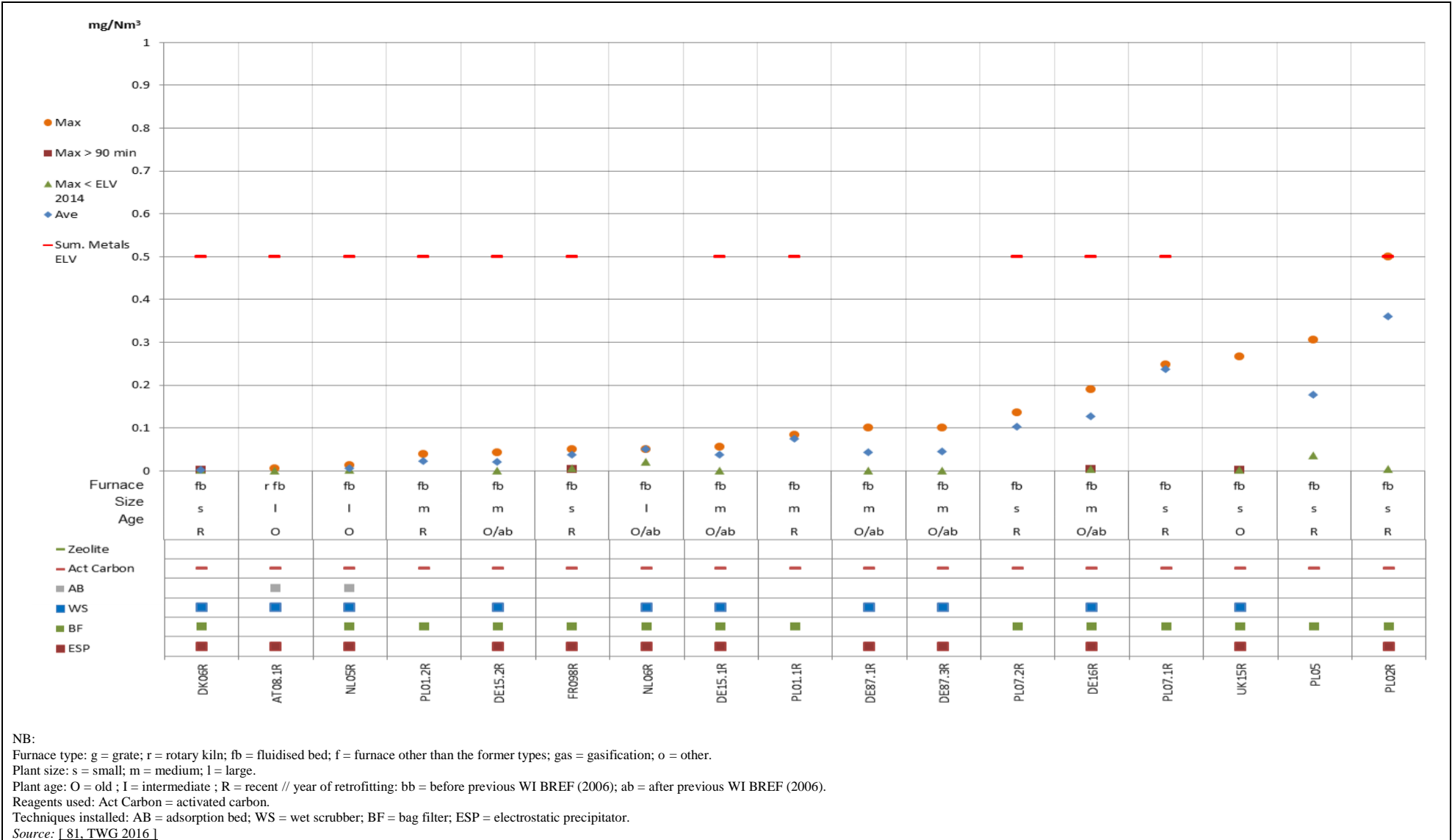

Figure 8.138: Emission levels for periodically monitored Sb+As+Cr+Co+Cu+Pb+Mn+Ni+V emissions to air from reference lines incinerating predominantly SS

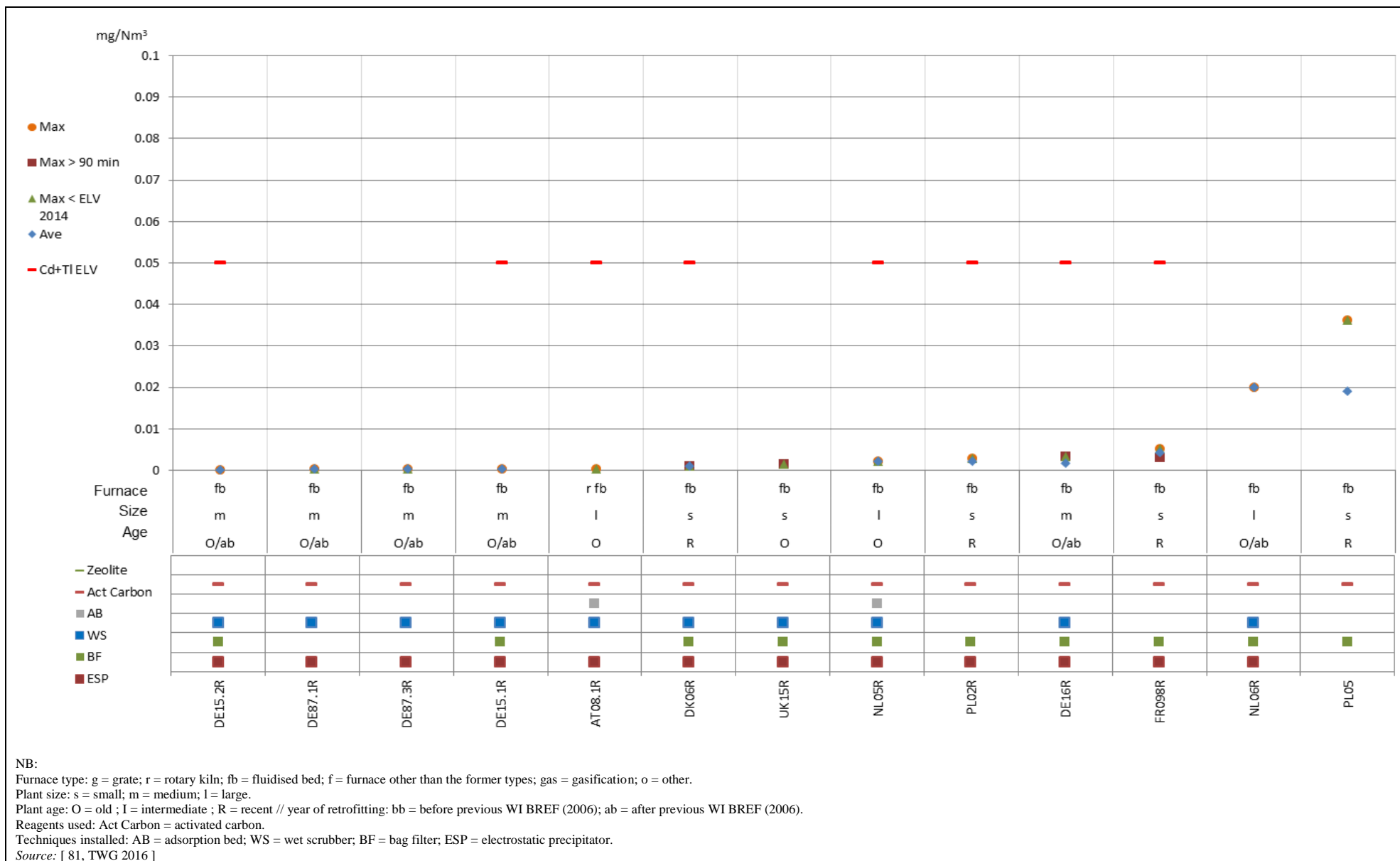

Figure 8.139: Emission levels for periodically monitored Cd+TI emissions to air from reference lines incinerating predominantly SS

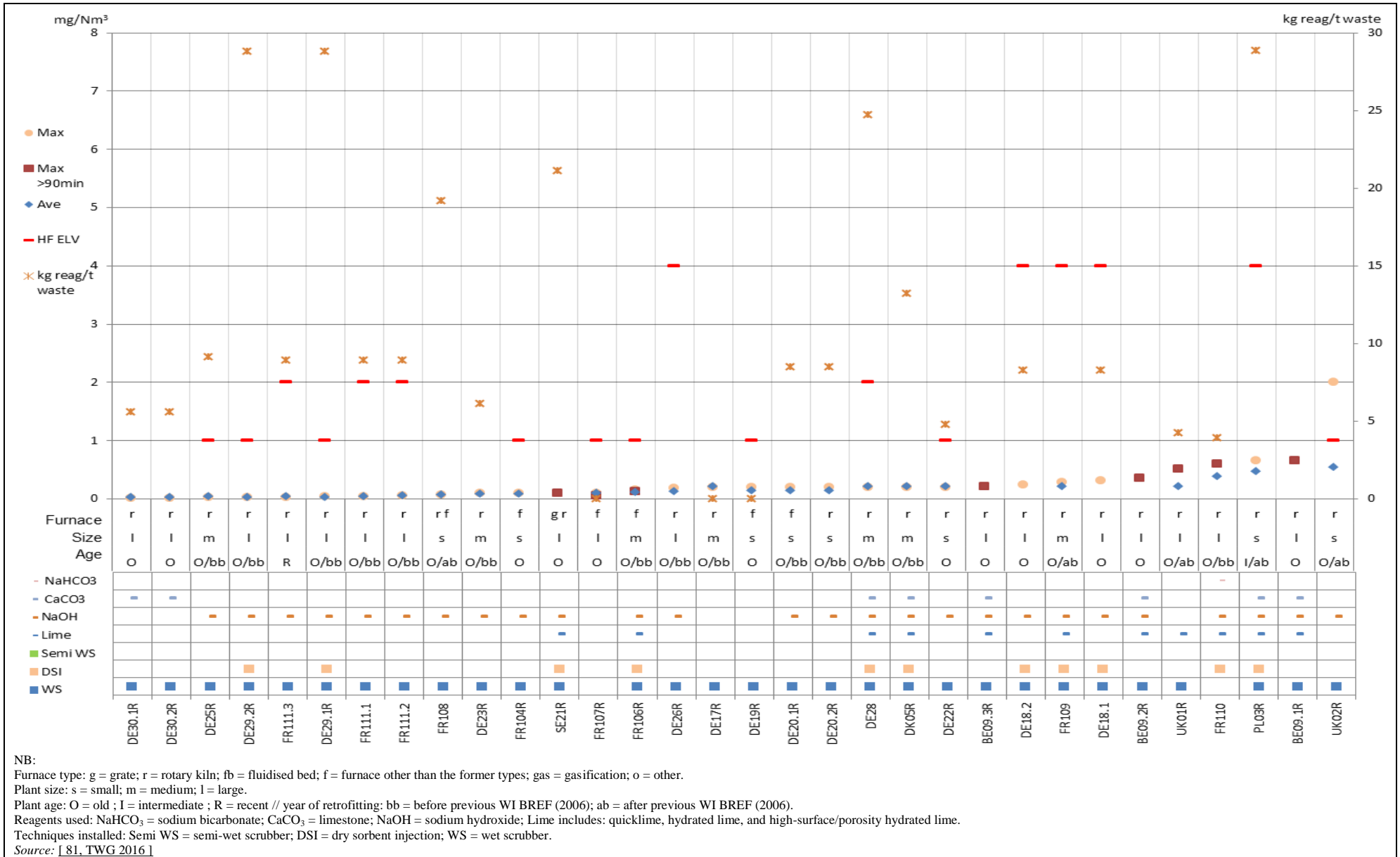
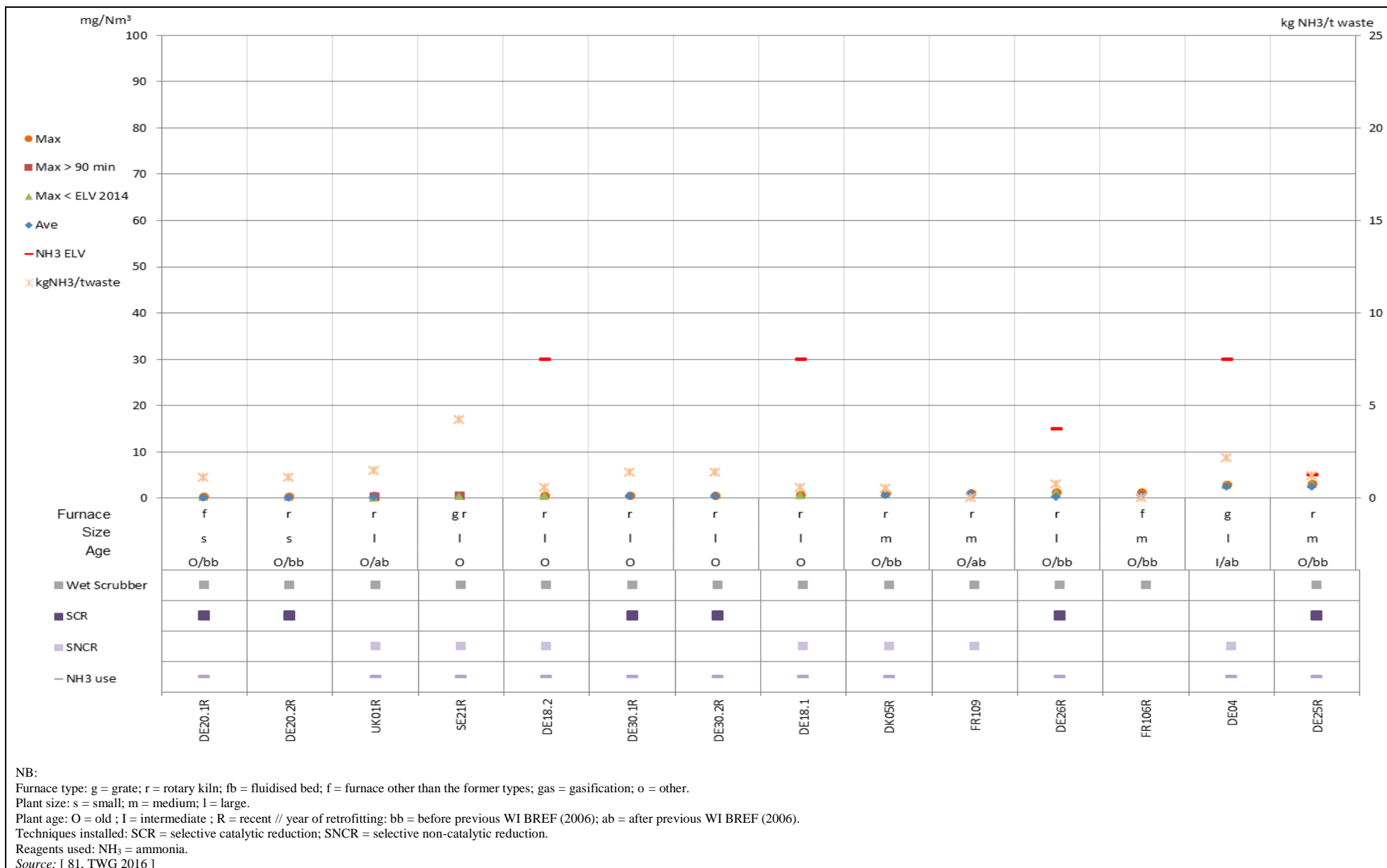

Figure 8.140: Emission levels for periodically monitored HF emissions to air from reference lines incinerating predominantly HW



NB:
 Furnace type: g = grate; r = rotary kiln; fb = fluidised bed; f = furnace other than the former types; gas = gasification; o = other.
 Plant size: s = small; m = medium; l = large.
 Plant age: O = old ; I = intermediate ; R = recent // year of retrofitting; bb = before previous WI BREF (2006); ab = after previous WI BREF (2006).
 Techniques installed: SCR = selective catalytic reduction; SNCR = selective non-catalytic reduction.
 Reagents used: NH₃ = ammonia.
 Source: [81, TWG 2016]

Figure 8.141: Emission levels for periodically monitored NH₃ emissions to air from reference lines incinerating predominantly HW

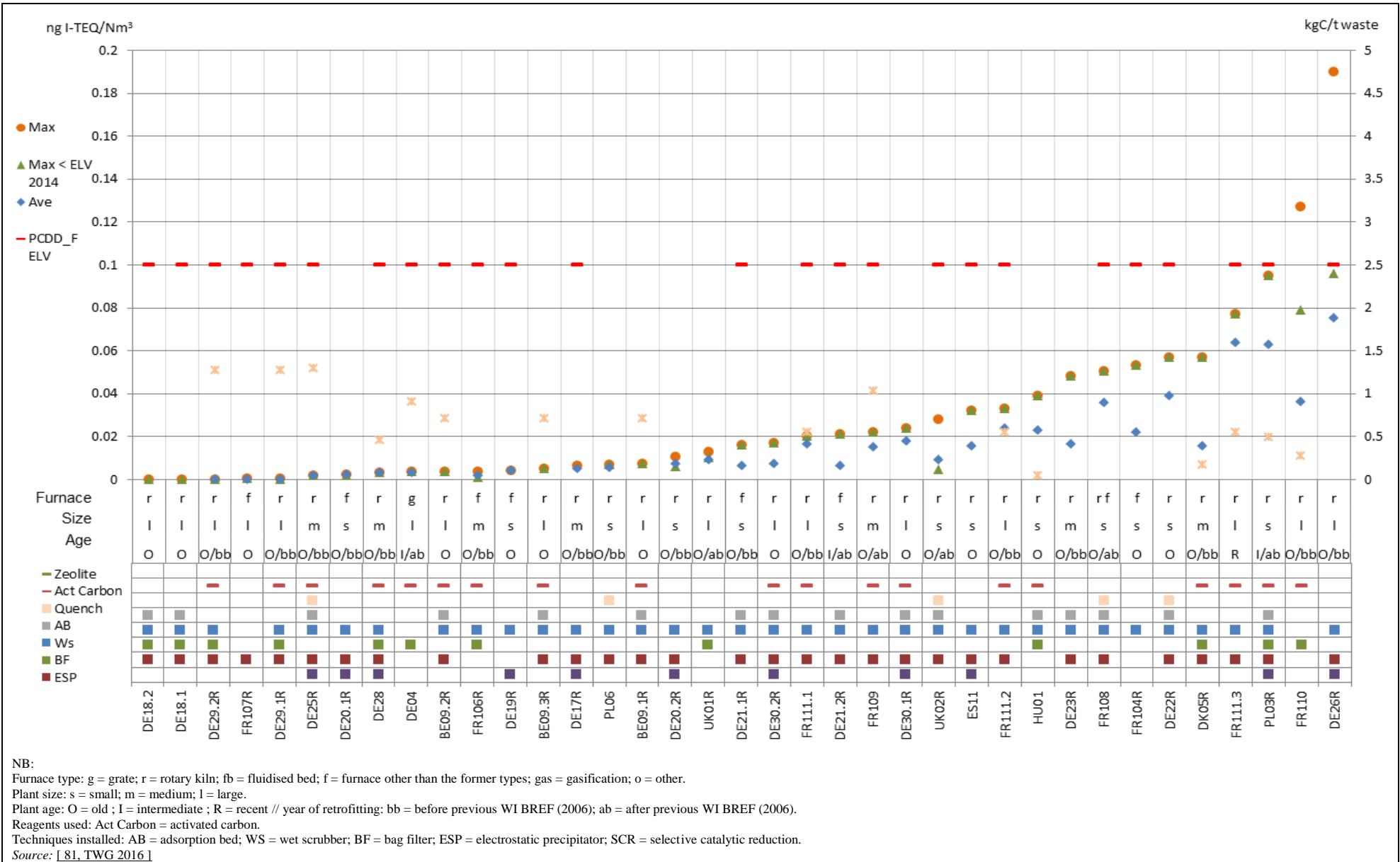

Figure 8.142: Emission levels for periodically monitored PCDD/F emissions to air from reference lines incinerating predominantly HW

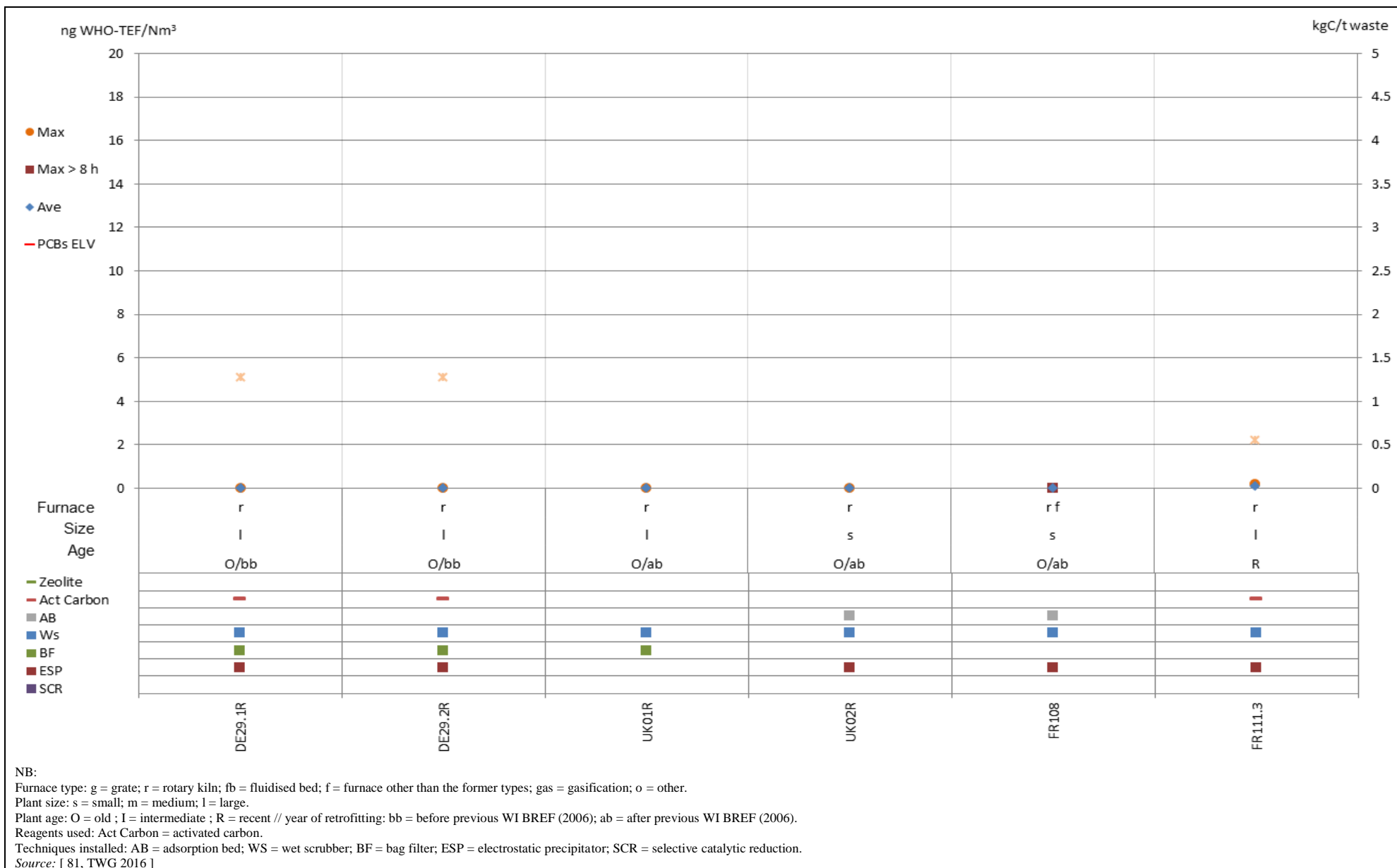

Figure 8.143: Emission levels for periodically monitored dioxin-like PCB emissions to air from reference lines incinerating predominantly HW

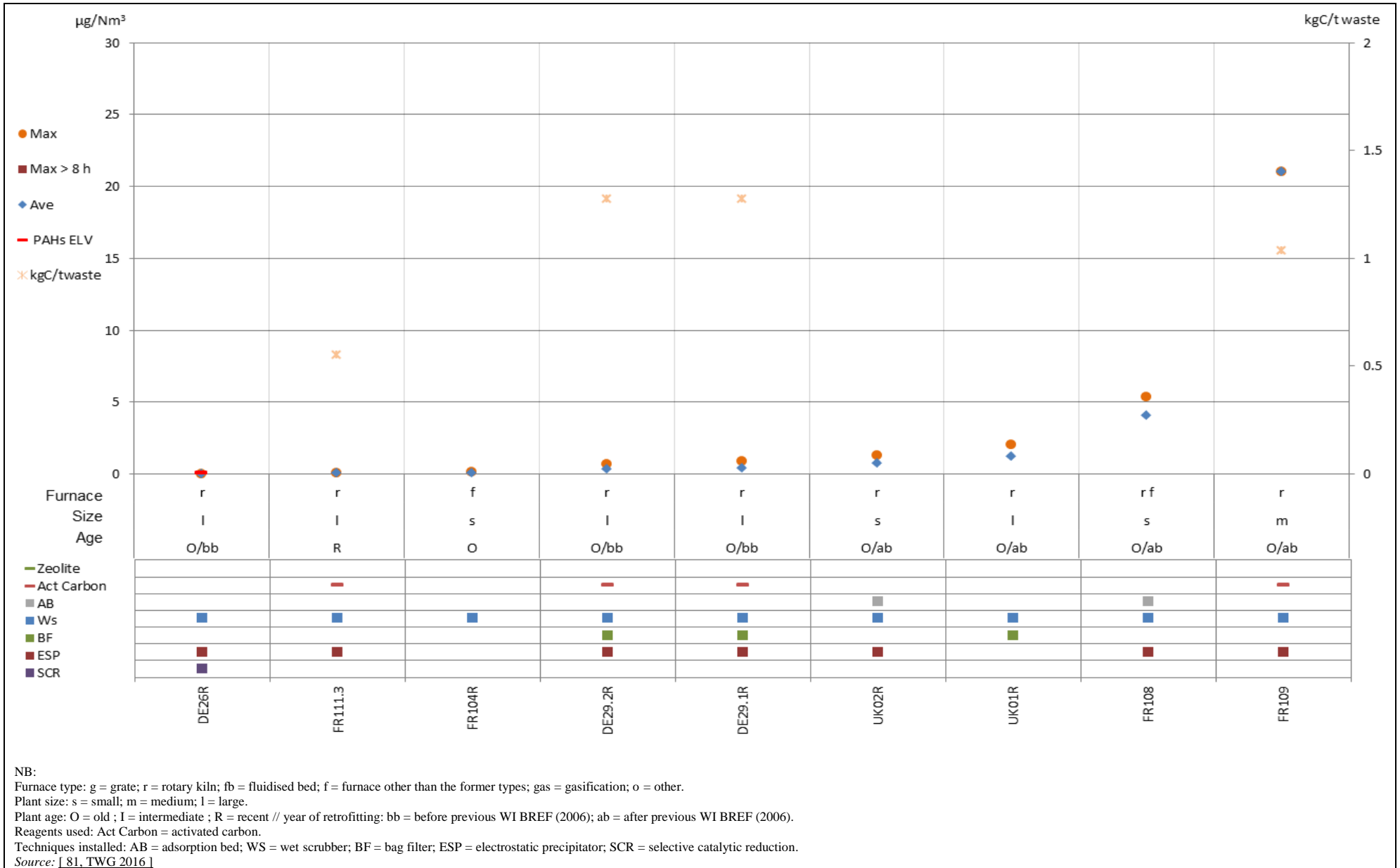

Figure 8.144: Emission levels for periodically monitored PAH emissions to air from reference lines incinerating predominantly HW

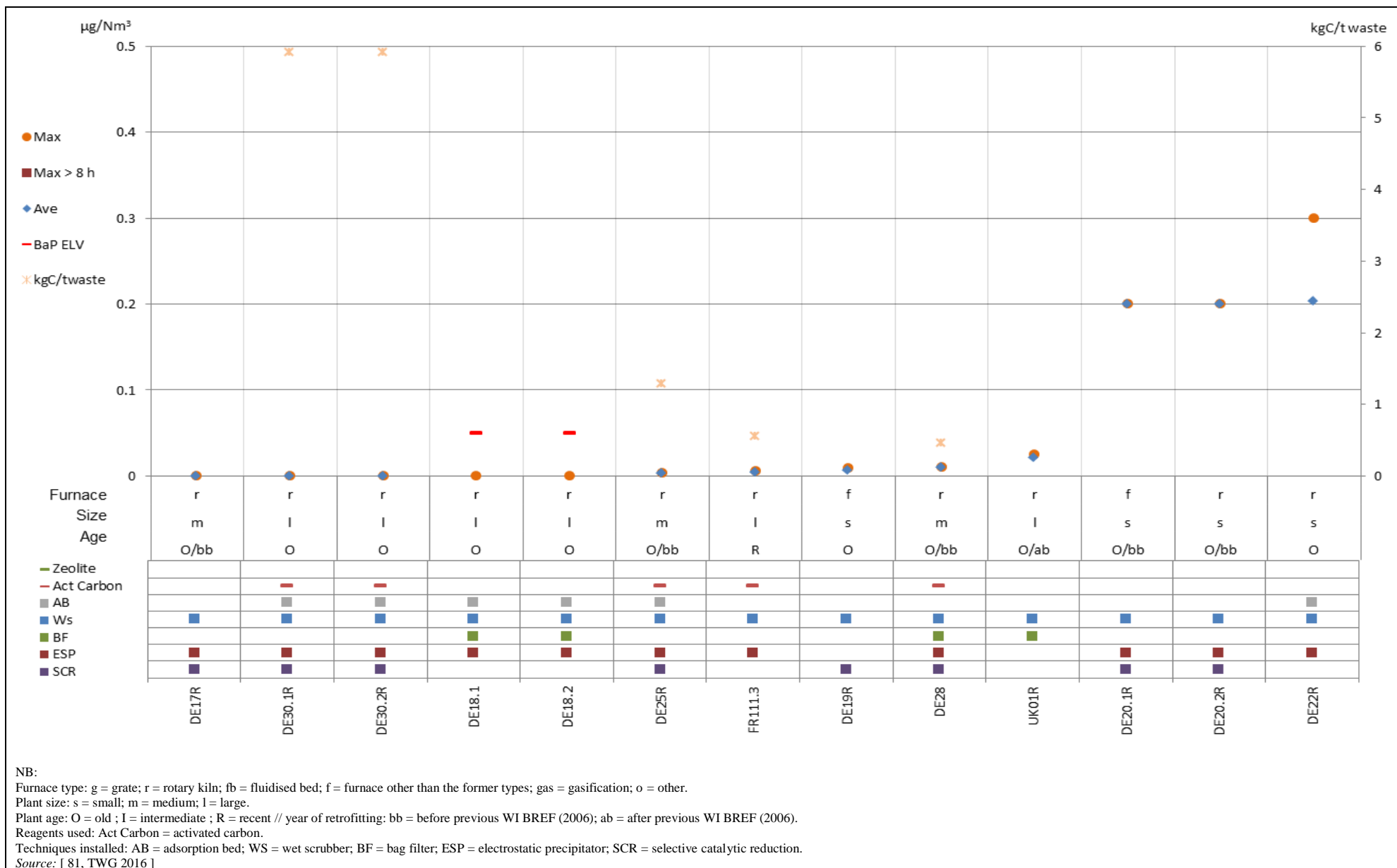

Figure 8.145: Emission levels for periodically monitored BaP emissions to air from reference lines incinerating predominantly HW

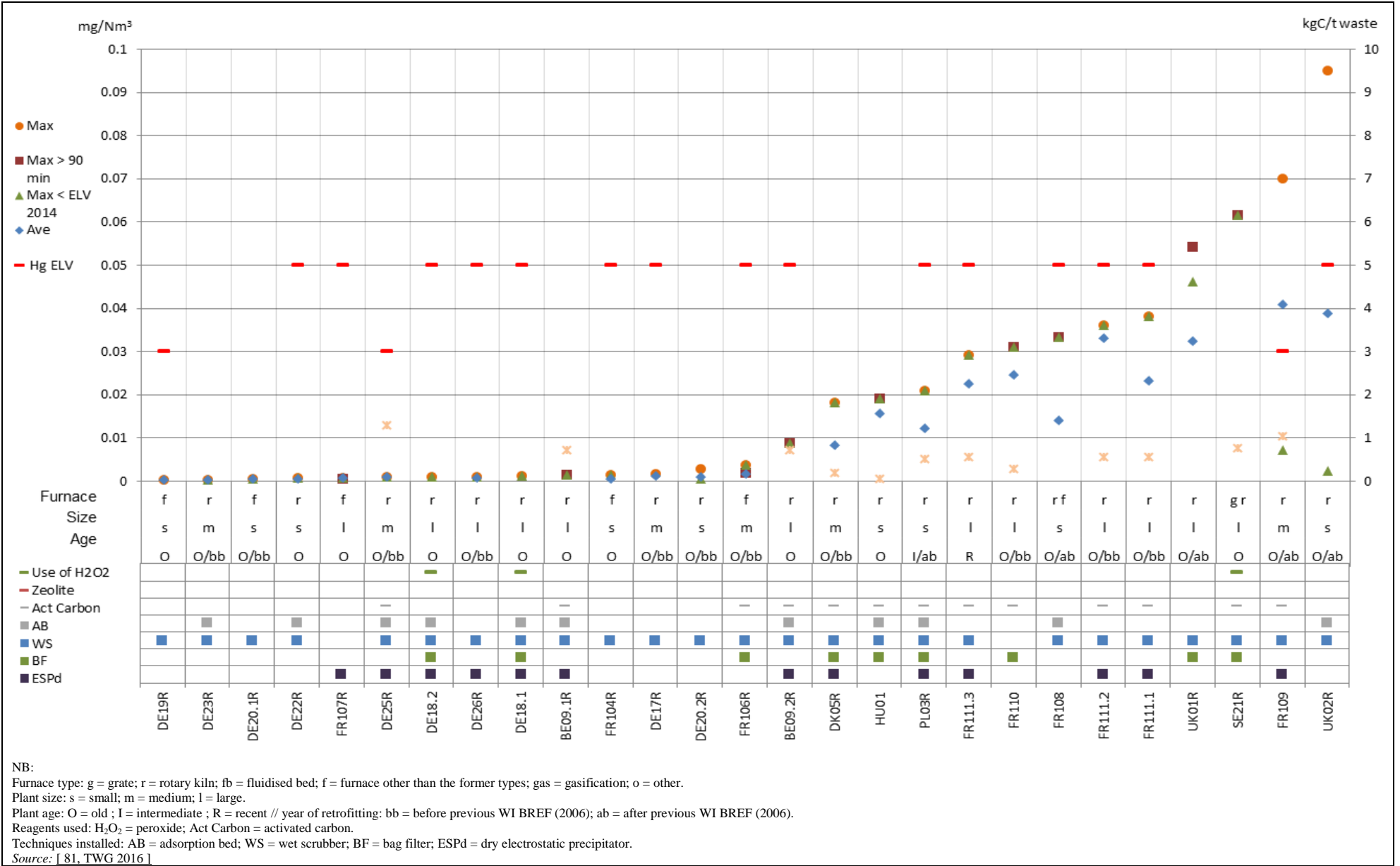

Figure 8.146: Emission levels for periodically monitored Hg emissions to air from reference lines incinerating predominantly HW

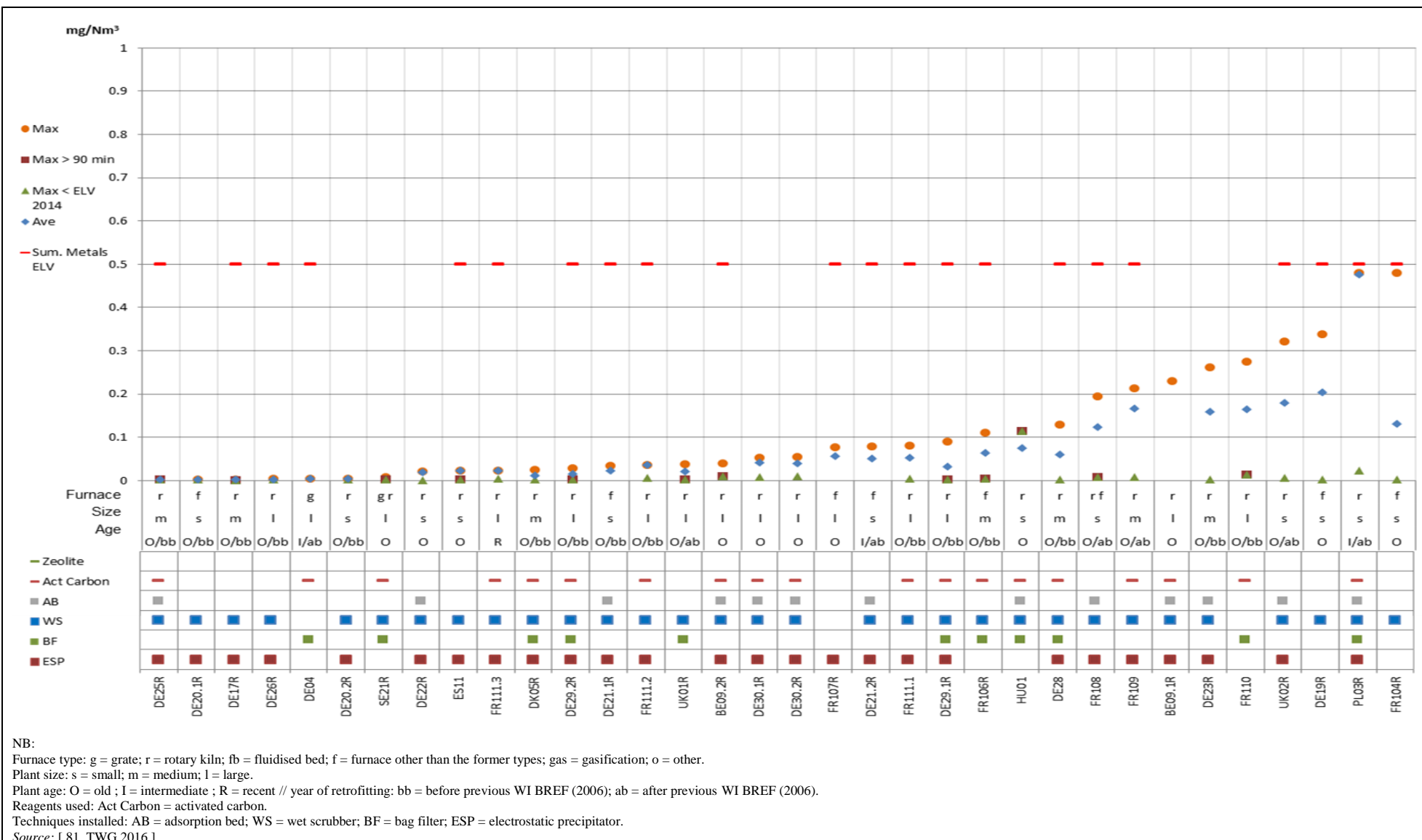
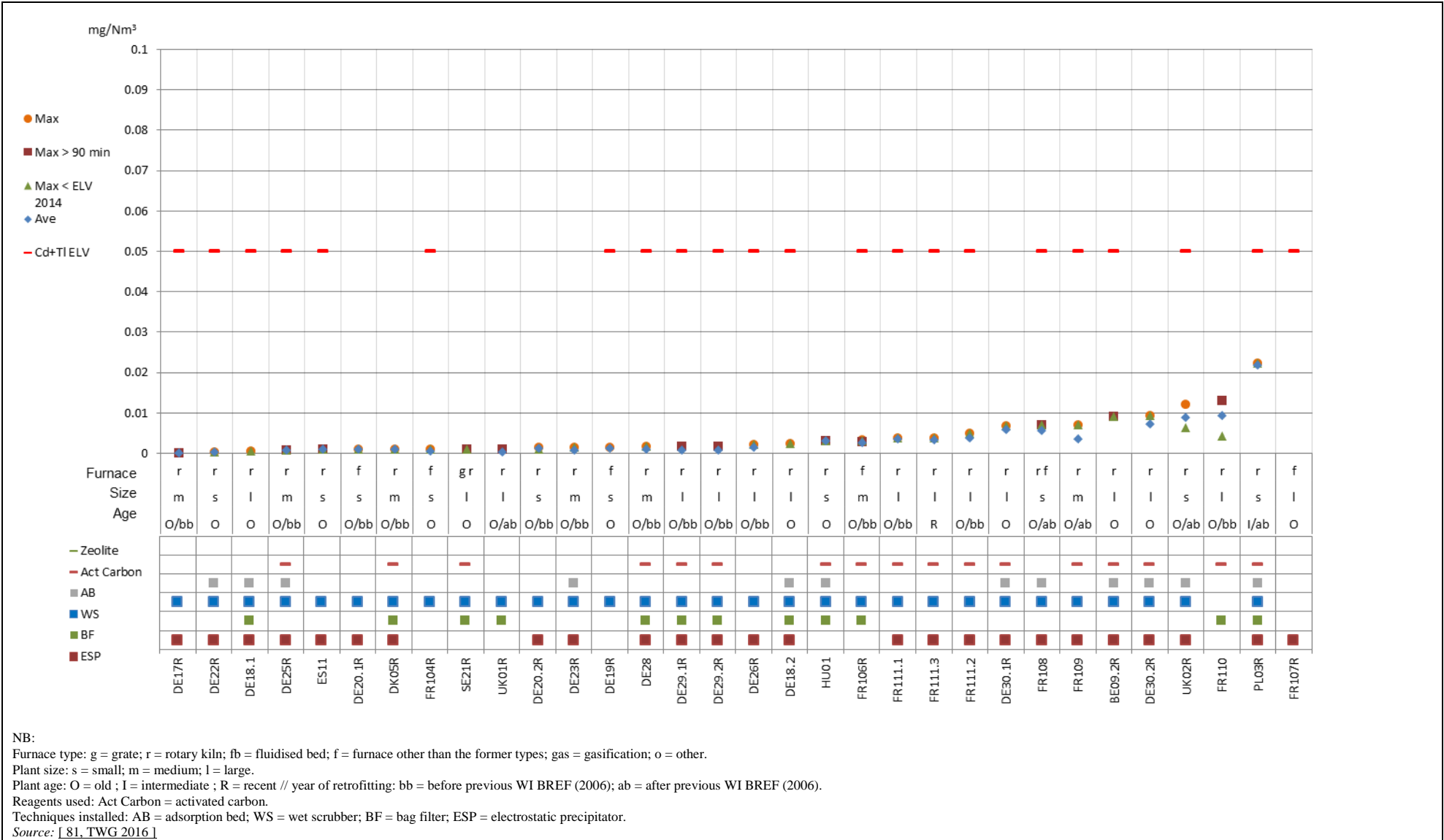

Figure 8.147: Emission levels for periodically monitored Sb+As+Cr+Co+Cu+Pb+Mn+Ni+V emissions to air from reference lines incinerating predominantly HW



NB:
 Furnace type: g = grate; r = rotary kiln; fb = fluidised bed; f = furnace other than the former types; gas = gasification; o = other.
 Plant size: s = small; m = medium; l = large.
 Plant age: O = old ; I = intermediate ; R = recent // year of retrofitting: bb = before previous WI BREF (2006); ab = after previous WI BREF (2006).
 Reagents used: Act Carbon = activated carbon.
 Techniques installed: AB = adsorption bed; WS = wet scrubber; BF = bag filter; ESP = electrostatic precipitator.
 Source: [81, TWG 2016]

Figure 8.148: Emission levels for periodically monitored Cd+Tl emissions to air from reference lines incinerating predominantly HW

8.9 Comparison of PCDD/F emission levels measured by short-term and long-term sampling at 142 waste incineration reference lines in Belgium and France

For the purpose of comparing the emission levels measured with short-term and with long-term sampling, emission data submitted by 142 reference lines in Belgium and France that performed both long-term and short-term sampling measurements over the same period of time. French data were submitted through two trade associations: FNADE/SVDU (Fédération Nationale des Activités de la Dépollution e de l'Environnement/Syndicat national du traitement et de la Valorisation des Déchets Urbains et assimilés) for waste-to-energy plants and HWE (Hazardous Waste Europe) for hazardous waste incineration plants.

Figure 8.149 shows a summary of the data provided by Belgium (17 reference lines, 3 of which are hazardous waste incineration lines, reporting 360 long-term measurements and 19 short-term measurements [135, Belgium 2018]), HWE (22 reference lines reporting 433 long-term measurements and 70 short-term measurements [137, HWE 2018]) and FNADE/SVDU (103 reference lines reporting 945 long-term measurements and 221 short-term measurements [136, SVDU-FNADE 2018]). For each of the three groups of plants, the figure shows the distribution of measurement results obtained with long-term and short-term sampling.

For the Belgian data, the figure shows for instance that: 82 % of the long-term measurements compared to 63 % of the short-term measurements are below 0.01 ng I-TEQ/Nm³, 13 % of the long-term measurements compared to 16 % of the short-term measurements are between 0.01 ng I-TEQ/Nm³ and 0.02 ng I-TEQ/Nm³, 4 % of the long-term measurements compared to 21 % of the short-term measurements are between 0.02 ng I-TEQ/Nm³ and 0.04 ng I-TEQ/Nm³, etc.

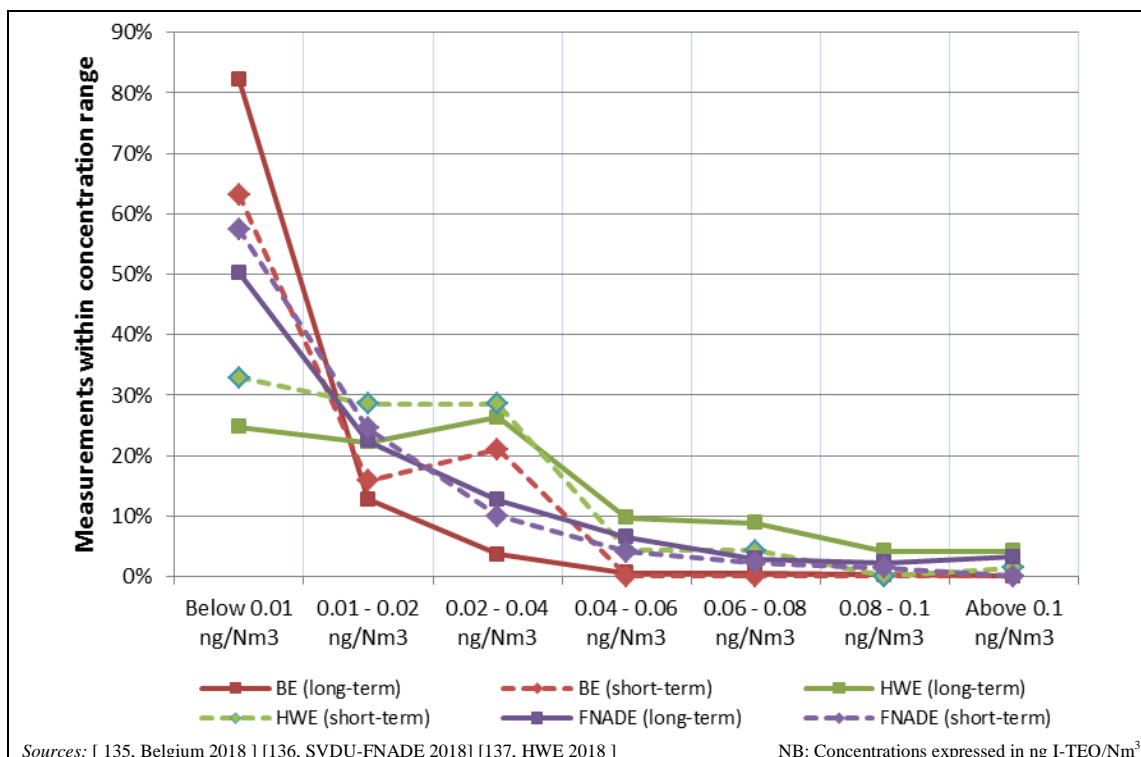

Figure 8.149: Distribution of PCDD/F measurements within different concentration ranges, achieved by the plants submitted by Belgium, FNADE/SVDU and HWE, based on short-term and long-term sampling

For the purpose of establishing an equivalence, in terms of performance of the plants, between values measured with short-term and long-term sampling, Figure 8.150 shows, cumulatively for the three data sets together (1 738 long-term measurements and 310 short-term measurements), the share of measurements falling below different concentration thresholds in the case of long-term and short-term sampling.

The figure shows for instance that: 51 % of the long-term measurements compared to 52 % of the short-term measurements are below 0.01 ng I-TEQ/Nm³, 71 % of the long-term measurements compared to 77 % of the short-term measurements are below 0.02 ng I-TEQ/Nm³, 85 % of the long-term measurements compared to 92 % of the short-term measurements are below 0.04 ng I-TEQ/Nm³, etc.

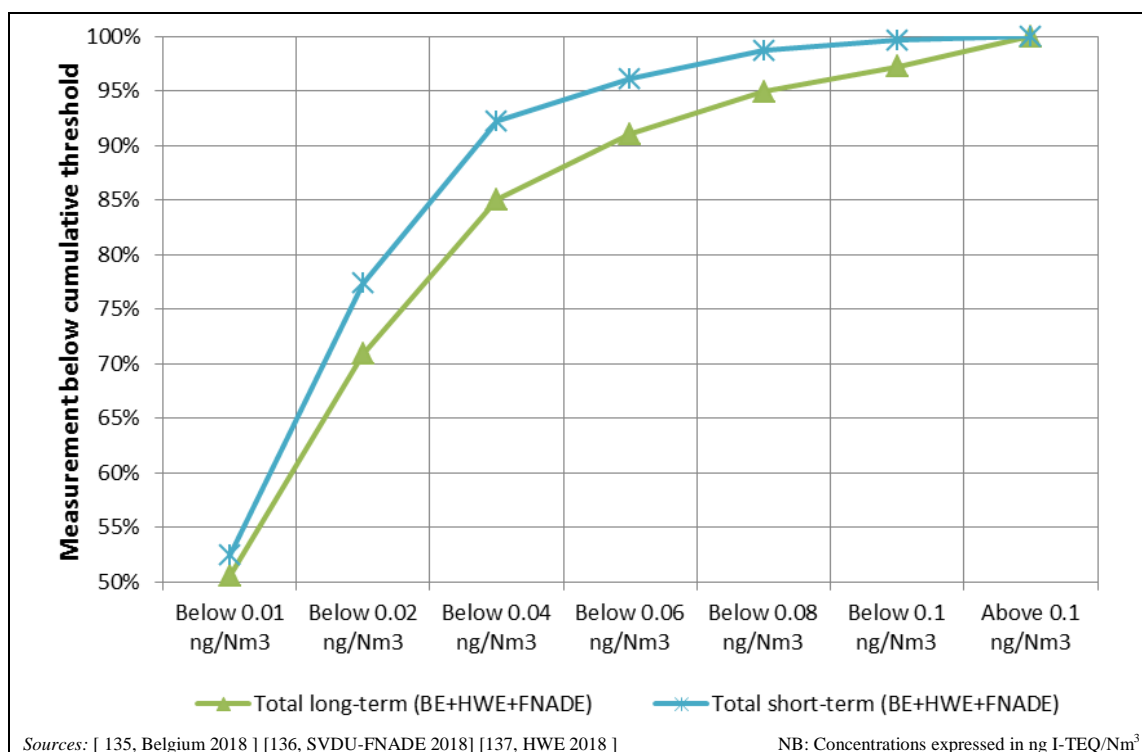

Figure 8.150: Percentage of measurements falling below different concentration thresholds, cumulatively for all the plants submitted by Belgium, FNADE/SVDU and HWE, for short-term and long-term measurements

The data analysis shows, cumulatively, the following:

- No significant difference is observed between the number of measurements below the proposed lower end of the BAT-AEL ranges of < 0.01 ng I-TEQ/ Nm³ (48 % of the short-term measurements and 49 % of the long-term measurements are above this level).
- A higher number of long-term measurements exceed the proposed higher ends of the BAT-AEL ranges, compared to the short-term measurements:
 - While 8 % of the short-term measurements are above a level of 0.04 ng I-TEQ/ Nm³, in the case of long-term sampling 15 % of the measurements are above the same level, and 9 % are above 0.06 ng I-TEQ/ Nm³.
 - While 4 % of the short-term measurements are above a level of 0.06 ng I-TEQ/ Nm³, in the case of long-term sampling 9 % of the measurements are above the same level, and 5 % are above 0.08 ng I-TEQ/ Nm³.
 - It is also noted that about 3 % of the long-term measurements are above 0.1 ng I-TEQ/ Nm³, including several measurements in the range of 0.3–0.6 ng I-TEQ/ Nm³. These measurements seem to be related to operating conditions outside

- the current compliance assessment regime and have the effect of skewing the distribution of long-term measurements towards high emission values.
- Overall, the additional data submitted by BE, HWE and FNADE/SVDU suggest the following equivalence in terms of PCDD/F emission performance of the WI plants: a level of 0.01 ng I-TEQ/ Nm³ measured by short-term sampling may be equivalent to 0.01 ng I-TEQ/ Nm³ measured by long-term sampling; a level of 0.04 ng I-TEQ/ Nm³ measured by short-term sampling may be equivalent to 0.06 ng I-TEQ/ Nm³ measured by long-term sampling; a level of 0.06 ng I-TEQ/ Nm³ measured by short-term sampling may be equivalent to 0.08 ng I-TEQ/ Nm³ measured by long-term sampling.

Some differences are observed in the relationship between the long-term sampling and periodic measurement results in the data submitted by Belgium and the data submitted by FNADE/SVDU and by HWE, which may be related to differences in implementing the long-term sampling method in France and in Belgium.

For the plant data submitted by FNADE/SVDU, for instance, 83 % of the periodic measurements, but only 72 % of the long-term sampling measurements, are below 0.02 ng I-TEQ/Nm³.

Conversely, for the Belgian plants the measured long-term sampling values are generally lower than the periodic measurements, with 95 % of the long-term sampling measurements, compared with 79 % of the periodic measurements, below 0.02 ng I-TEQ/Nm³. However, it is also noted that four of the long-term sampling measurements of the Belgian plants report values between 0.04 ng I-TEQ/Nm³ and 0.08 ng I-TEQ/Nm³, whereas all the periodic measurements for the same plants are below 0.04 ng I-TEQ/Nm³.

FNADE/SVDU reported a correlation between elevated values obtained by long-term sampling measurements and the number of start-ups/shut-downs occurring in the time period during which the sampling was performed.

GLOSSARY

This glossary is meant to facilitate the understanding of the information contained in this document. The definitions of terms in this glossary are not legal definitions (even if some of them may coincide with definitions given in European legislation), they are meant to help the reader understand some key terms in the context of their use in the specific sector covered by this document.

This glossary is divided into the following sections:

- I. ISO country codes
- II. Monetary units
- III. Unit prefixes, number separators and notations
- IV. Units and measures
- V. Chemical elements
- VI. Chemical formulae commonly used in this document
- VII. Acronyms
- VIII. Definitions

I. ISO country codes

ISO code	Country
<i>Member States</i> (°)	
AT	Austria
BE	Belgium
BG	Bulgaria
CZ	Czech Republic
CY	Cyprus
DE	Germany
DK	Denmark
EE	Estonia
EL	Greece
ES	Spain
FI	Finland
FR	France
HR	Croatia
HU	Hungary
IE	Ireland
IT	Italy
LT	Lithuania
LU	Luxembourg
LV	Latvia
MT	Malta
NL	Netherlands
PL	Poland
PT	Portugal
RO	Romania
SE	Sweden
SI	Slovenia
SK	Slovakia
UK	United Kingdom
<i>Non-member countries</i>	
NO	Norway
(°) The protocol order of the Member States is based on the alphabetical order of their geographical names in the original language(s).	

II. Monetary units

Code ⁽¹⁾	Country/territory	Currency
<i>Member State currencies</i>		
EUR	Euro area ⁽²⁾	euro (pl. euros)
DKK	Denmark	Danish krone (pl. kroner)
GBP	United Kingdom	pound sterling (pl. pounds sterling)
<i>Other currencies</i>		
USD	United States	US dollar (pl. US dollars)
<p>⁽¹⁾ ISO 4217 codes. ⁽²⁾ Includes Austria, Belgium, Cyprus, Estonia, Finland, France, Germany, Greece, Ireland, Italy, Luxembourg, Malta, the Netherlands, Portugal, Slovakia, Slovenia and Spain.</p>		

III. Unit prefixes, number separators and notations

Numbers in this document are written using the '.' character as the decimal separator and the space as the separator for thousands.

The symbol ~ (around; about) is the notation used to indicate approximation.

The symbol Δ (delta) is the notation used to indicate a difference.

The following table contains the frequently used prefixes:

Symbol	Prefix	10^n	Word	Decimal number
T	tera	10^{12}	Trillion	1 000 000 000 000
G	giga	10^9	Billion	1 000 000 000
M	mega	10^6	Million	1 000 000
k	kilo	10^3	Thousand	1 000
-----	-----	1	One	1
m	milli	10^{-3}	Thousandth	0.001
μ	micro	10^{-6}	Millionth	0.000 001
n	nano	10^{-9}	Billionth	0.000 000 001

IV. Units and measures

Unit symbol	Unit name	Measure name (measure symbol)	Conversion and comment
atm	normal atmosphere	Pressure (P)	1 atm = 101 325 N/m ²
bar	bar	Pressure (P)	1.013 bar = 100 kPa = 1 atm
°C	degree Celsius	Temperature (T) temperature difference (ΔT)	
d	day	Time	
g	gram	Weight	
h	hour	Time	
J	joule	Energy	
K	Kelvin	Temperature (T) temperature difference (ΔT)	0 °C = 273.15 K
kcal	kilocalorie	Energy	1 kcal = 4.1868 kJ
kg	kilogram	Weight	
kJ	kilojoule	Energy	
kPa	kilopascal	Pressure	
kWh	kilowatt-hour	Energy	1 kWh = 3 600 kJ
l	litre	Volume	
m	metre	Length	
m ²	square metre	Area	
m ³	cubic metre	Volume	
mg	milligram	Weight	1 mg = 10 ⁻³ g
mm	millimetre		1 mm = 10 ⁻³ m
min	minute		
MW _e	megawatts electric (energy)	Electric energy	
MW _{th}	megawatts thermal (energy)	Thermal energy Heat	
nm	nanometre		1 nm = 10 ⁻⁹ m
Nm ³	normal cubic metre	Volume	at 101.325 kPa, 273.15 K
OU _E	European odour unit	Odour	
Pa	pascal		1 Pa = 1 N/m ²
ppb	parts per billion	Composition of mixtures	1 ppb = 10 ⁻⁹
ppm	parts per million	Composition of mixtures	1 ppm = 10 ⁻⁶
ppmv	parts per million by volume	Composition of mixtures	
rpm RPM	Revolutions per minute	Rotational speed, frequency	
s	second	Time	
St	stokes	Kinematic viscosity	1 St = 10 ⁻⁴ m ² /s; old, cgs unit
t	metric tonne	Weight	1 t = 1 000 kg or 10 ⁶ g
t/d	tonnes per day	Mass flow Materials consumption	
t/yr	tonnes per year	Mass flow Materials consumption	
vol-% % v/v	percentage by volume	Composition of mixtures	
wt-% % w/w	percentage by weight	Composition of mixtures	
W	watt	Power	1 W = 1 J/s
yr	year	Time	
μm	micrometre	Length	1 μm = 10 ⁻⁶ m

V. Chemical elements

Symbol	Name	Symbol	Name
Ac	Actinium	Mn	Manganese
Ag	Silver	Mo	Molybdenum
Al	Aluminium	N	Nitrogen
Am	Americium	Na	Sodium
Ar	Argon	Nb	Niobium
As	Arsenic	Nd	Neodymium
At	Astatine	Ne	Neon
Au	Gold	Ni	Nickel
B	Boron	No	Nobelium
Ba	Barium	Np	Neptunium
Be	Beryllium	O	Oxygen
Bi	Bismuth	Os	Osmium
Bk	Berkelium	P	Phosphorus
Br	Bromine	Pa	Protactinium
C	Carbon	Pb	Lead
Ca	Calcium	Pd	Palladium
Cd	Cadmium	Pm	Promethium
Ce	Cerium	Po	Polonium
Cf	Californium	Pr	Praseodymium
Cl	Chlorine	Pt	Platinum
Cm	Curium	Pu	Plutonium
Co	Cobalt	Ra	Radium
Cr	Chromium	Rb	Rubidium
Cs	Caesium	Re	Rhenium
Cu	Copper	Rf	Rutherfordium
Dy	Dysprosium	Rh	Rhodium
Er	Erbium	Rn	Radon
Es	Einsteinium	Ru	Ruthenium
Eu	Europium	S	Sulphur
F	Fluorine	Sb	Antimony
Fe	Iron	Sc	Scandium
Fm	Fermium	Se	Selenium
Fr	Francium	Si	Silicon
Ga	Gallium	Sm	Samarium
Gd	Gadolinium	Sn	Tin
Ge	Germanium	Sr	Strontium
H	Hydrogen	Ta	Tantalum
He	Helium	Tb	Terbium
Hf	Hafnium	Tc	Technetium
Hg	Mercury	Te	Tellurium
Ho	Holmium	Th	Thorium
I	Iodine	Ti	Titanium
In	Indium	Tl	Thallium
Ir	Iridium	Tm	Thulium
K	Potassium	U	Uranium
Kr	Krypton	V	Vanadium
La	Lanthanum	W	Tungsten
Li	Lithium	Xe	Xenon
Lr	Lawrencium	Y	Yttrium
Lu	Lutetium	Yb	Ytterbium
Md	Mendelevium	Zn	Zinc
Mg	Magnesium	Zr	Zirconium

VI. Chemical formulae commonly used in this document

Chemical formula	Name (explanation)
CH ₄	Methane
Cl ⁻	Chloride ion
CN ⁻	Cyanide ion
CO	Carbon monoxide
F ⁻	Fluoride ion
HCl	Hydrogen chloride
HF	Hydrogen fluoride
H ₂ S	Hydrogen sulphide
H ₂ SO ₄	Sulphuric acid
NaOH	Sodium hydroxide. Also called caustic soda
NH ₃	Ammonia
N ₂ O	Nitrous oxide
NO ²⁻	Nitrite ion
NO ³⁻	Nitrate ion
NO _x	Nitrogen oxides (mixture of NO and NO ₂)
SO ₃ ²⁻	Sulphite ion
SO _x	Sulphur oxides (mixture of SO ₂ and SO ₃)

VII. Acronyms

Acronym	Full phrase
ACC	Air-cooled condenser
AMS	Automated measuring system
APC	Air pollution control, term used elsewhere for flue-gas cleaning (FGC)
BAT	Best Available Techniques, as defined in Article 3(10) of the IED
BAT-AEL	Best Available Techniques - associated emission level, as defined in Article 3(13) of the IED
BAT-AEPL	Best Available Techniques - associated performance emission level, as described in Section 3.3.2 of Commission Implementing Decision 2012/119/EU
BF	Bag filter
BFB	Bubbling fluidised bed – a type of fluidised bed (see also CFB)
BOD	Biochemical oxygen demand
BREF	Best available techniques (BAT) reference document
BTEX	Benzene, toluene, ethylbenzene, xylene
CAPEX	Capital expenditure
CAS	Chemical abstracts service (chemicals registry number)
CEFIC	Conseil Européen de l'Industrie Chimique (European Chemical Industry Council)
CEN	Comité Européen de Normalisation (European Committee for standardisation)
CFB	Circulating fluidised bed – a type of fluidised bed (see also BFB)
CFC	Chlorofluorocarbons
CFD	Computerised fluid dynamics - a modelling technique used to predict gas flow and temperature in incinerators and other systems
CHP	Combined heat and power (cogeneration)
COD	Chemical oxygen demand
CV	Calorific value, e.g. in MJ/kg or MJ/m ³
DIN	Deutsches Institut für Normung (German national organisation for standardisation)
DE	Destruction efficiency - the overall percentage of the substance that is fed to an incineration process that is destroyed and not then emitted to all combined environmental media
DRE	Destruction and removal efficiency - the percentage of a substance fed to an incineration process that is not then emitted from the stack
DH	District heating – a network supplying heat via hot water or steam
DS	Dry solids (content)
EA	Environment Agency (England and Wales)
EEA	European Environment Agency
EFTA	European Free Trade Association
ELV	Emission limit value
EMAS	Eco-Management and Audit Scheme (Council Regulation (EC) No 1221/2009)
EMS	Environmental management system
EN	European Norming (EN standards)
EPA	Environmental Protection Agency (US)
ESP	Electrostatic precipitator
EQS	Environmental quality standard
EU	European Union
EU+	European Union + EFTA (European Free Trade Association) countries + Candidate countries
EWC	European waste code
FB	Fluidised bed
FBC	Fluidised bed combustion

Acronym	Full phrase
FD	Forced draught – often used in the context of forced draught fans which use positive pressure to activate (typically) downstream FGC equipment (see also ID)
FGC	Flue-gas cleaning
FGR	Flue-gas recirculation
FGT	Flue-gas treatment, term used elsewhere for flue-gas cleaning (FGC)
FID	Flame ionisation detector
GHG	Greenhouse gases (e.g. CO ₂)
HCB	Hexachlorobenzene
HCFC	Hydrochlorofluorocarbons
HFC	Hydrofluorocarbons
HFO	Heavy fuel oil
HP	High pressure
HW	Hazardous waste
HWI	Hazardous waste incinerator
IBA	Incinerator bottom ash
ID	Induced draught – often used in the context of induced draught fans that are used to draw incineration gases through the incineration plant
IED	Industrial Emission Directive (2010/75/EU)
IPPC	Integrated pollution prevention and control
IR	Infrared
ISO	International Organisation for Standardisation
JRC	Joint Research Centre
L/S	Liquid/solid ratio
LCA	Life cycle assessment.
LCP	Large combustion plant
LDAR	Leak detection and repair
LFO	Light fuel oil
LHV	Lower heating value
LOI	Loss on ignition – often referred to in the context of a test used for assessing organic content of materials
LoW	List of Waste (from COM Decision 2000/532/EC)
LPG	Liquefied petroleum gas
LOQ	Limit of quantification
MP	Medium pressure
MS	(European Union) Member State
MSW	Municipal solid waste
MSWI	Municipal solid waste incinerator
N	Normal – refers to volume of gases under normal operating conditions with a temperature of 273.15 K and pressure of 101.325 kPa
NA	Not applicable
ND	Not determined / Not detectable
NGO	Non-governmental organisation
NI	No information
NIRS	Near-infrared spectroscopy
NMVOG	Non-methane volatile organic compound
NOC	Normal operating conditions
ODS	Ozone depletion substances – as defined by the Montreal Protocol
OJ	Official Journal (of the EU)
OPEX	Operating expenditure/costs
OTNOC	Other than normal operating conditions
PAC	Powdered activated carbon
PAHs	Polycyclic aromatic hydrocarbons
PCBs	Polychlorinated biphenyls
PCC	Post-combustion chamber - a term applied to the zone after the initial combustion zone where gas burnout occurs (also referred to as the secondary combustion chamber or SCC)
PCDD/F	Polychlorinated dibenzodioxins/dibenzofurans
PEMS	Predictive emissions monitoring system

Acronym	Full phrase
PIC(s)	Products of incomplete combustion
PM	Particulate matter
POPs	Persistent organic pollutants
PRTR	European Pollutant Release and Transfer Register
PSA	Pressure swing adsorption
QMS	Quality management system
RDF	Refuse-derived fuel
SCR	Selective catalytic reduction
SD	Shutdown
SNCR	Selective non-catalytic reduction
SRF	Solid recovered fuel, see RDF
SS	Sewage sludge
SSI	Sewage sludge incinerator
SU	Start-up
TDS	Total dissolved solids
TEQ	Toxicity equivalents (iTEQ: international toxicity equivalents)
TG	Turbo-generator
TOC	Total organic carbon
TMT	2,4,6-Trimercapto-1,3,5-triazine - A sulphide reagent used for heavy metal capture in WWT plants
TSS	Total suspended solids
TWG	Technical Working Group
UV	Ultraviolet
VOC	Volatile organic compound
WDF	Waste Derived Fuel (also referred to as RDF)
WEP	Wet electrostatic precipitator
WI	Waste incinerator/incineration
WFD	Waste Framework Directive (2008/98/EC), now superseded by the IED
WT	Waste treatment
WWT(P)	Waste water treatment (plant)

VIII. Definitions

Activated sludge process	A biological process for treating municipal and industrial waste waters by the use of microorganisms under aerobic conditions.
Aerobic processes	Biological processes that occur in the presence of oxygen.
Anaerobic processes	Biological processes that occur in the absence of oxygen and other electron accepting substances except carbon dioxide/carbonate.
Biofuel	Biofuel as defined in Article 2(i) of Directive 2009/28/EC.
Biomass	Biomass as defined in Article 2(e) of Directive 2009/28/EC.
Biowaste	Biowaste as defined in Article 3(4) of Directive 2008/98/EC.
Boiler ash	The part of the fly ash that is removed from the boiler.
Boiler efficiency	Ratio between the energy produced at the boiler output (e.g. steam, hot water) and the waste's and auxiliary fuel's energy input to the furnace (as lower heating values).
Bottom ashes	Solid residues from a combustion process, see Slags and/or bottom ashes.
Bottom ash treatment plant	Plant treating slags and/or bottom ashes from the incineration of waste in order to separate and recover the valuable fraction and to allow the beneficial use of the remaining fraction. This does not include the sole separation of coarse metals at the incineration plant.
By-product	A substance or object, resulting from a production process, the primary aim of which is not the production of that item and which is not regarded as being waste, and which meets the requirements of Article 5 of Directive 2008/98/EC on waste.
Cake	Solid or semi-solid material remaining on a filter after pressure filtration.
CAS	Chemical abstracts service (registry number). A division of the American Chemical Society holds registries of chemical substances; providing a unique numerical identifier for chemical compounds, polymers, biological sequences, mixtures and alloys which designates only one substance.
Certification	Procedure by which a third party gives written assurance that a product, process or service conforms to specified requirements. Certification can apply to instruments, equipment and/or personnel.
Channelled emissions	Emissions of pollutants into the environment through any kind of duct, pipe, stack, chimney, funnel, flue, etc.
Clinical waste	Infectious or otherwise hazardous waste arising from healthcare institutions (e.g. hospitals)
Composite sample	A composite sample refers to a water sample which is taken continuously over a given period, or a sample consisting of several samples taken either continuously or discontinuously over a given period (e.g. during 24 hours) and blended.
Continuous measurement	Measurement using an automated measuring system permanently installed on site.
Cooling water	Water used for energy transfer (heat removal from components and industrial equipment), which is kept in a network separated from industrial water and which can be released back to receiving waters without further treatment.
Decommissioning	The shutdown of an installation including decontamination and/or dismantling.
Diffuse emissions	Non-channelled emissions (e.g. of dust, volatile compounds, odour) into the environment, which can result from 'area' sources (e.g. tankers) or 'point' sources (e.g. pipe flanges).
Digestate	The solid residue remaining after anaerobic digestion.
Dioxins	Polychlorinated dibenzodioxins (PCDDs) and polychlorinated dibenzofurans (PCDFs).
Direct measurements	Specific quantitative determination of the emitted compounds at source.
Discharge	Physical release of a pollutant through a defined outlet (i.e. channelled) or system (e.g. sewer, stack, vent, curbing area, outfall).
Discrete	Not continuous, i.e. having gaps between all possible values.

Drainage	Natural or artificial removal of surface and subsurface water from an area, including surface streams and groundwater pathways.
Draining	Emptying the liquid contents of a system to a collection system or other storage system, creating a possible liquid waste stream.
Emission	The direct or indirect release of substances, vibrations, heat or noise from individual or diffuse sources in the installation into the air, water or land (from Directive 2010/75/EU).
Exhaust gas (or exhaust air)	Gas/air stream coming off a combustion or extraction process; it may contain gaseous or particulate components. There is no link with exhausting through a stack.
Existing plant	A plant that is not a new plant.
Flue-gas	A mixture of combustion products and air leaving a combustion chamber and being directed up a stack to be emitted.
Fly ashes	Particles from the combustion chamber or formed within the flue-gas stream that are transported in the flue-gas.
Fouling	A process of becoming dusty or clogged, e.g. by undesirable foreign matter, such as dirt and other material, accumulating and clogging pores and coating surfaces.
Fugitive emissions	Emissions of pollutants into the environment resulting from a gradual loss of tightness of a piece of equipment designed to contain an enclosed fluid (gaseous or liquid). Fugitive emissions are a subset of diffuse emissions.
Flaring	High-temperature oxidation to burn combustible compounds of waste gases from industrial operations with an open flame. Flaring is primarily used for burning off flammable gas for safety reasons or during non-routine operating conditions.
Hazardous waste	Hazardous waste as defined in Article 3(2) of Directive 2008/98/EC.
IED	Directive 2010/75/EU of the European Parliament and of the Council of 24 November 2010 on industrial emissions (integrated pollution prevention and control).
Incineration of waste	The combustion of waste, either alone or in combination with fuels, in an incineration plant.
Incineration plant	Either a waste incineration plant as defined in Article 3(40) of Directive 2010/75/EU, or a waste co-incineration plant as defined in Article 3(41) of Directive 2010/75/EU, covered by the scope of this BREF.
IPPC Directive	Directive 2008/1/EC of the European Parliament and of the Council of 15 January 2008 concerning integrated pollution prevention and control that has been replaced by Directive 2010/75/EU on industrial emissions (see IED).
Laboratory smalls	Laboratory chemicals in containers of a small capacity.
Leachate	Solution obtained by leaching. The solution consists of liquid that, in passing through matter, extracts solutes, suspended solids or any other component of the material through which it has passed.
Leakage	Gaseous or liquid spills out of system/equipment due to system/equipment failure.
Limestone	Mineral rock consisting merely of CaCO ₃ used as CaCO ₃ or as raw material for producing quicklime (calcium oxide) by calcination and hydrated lime (calcium hydroxide) by the hydration of quicklime.
Major plant upgrade	A major change in the design or technology of a plant with major adjustments or replacements of the process and/or abatement technique(s) and associated equipment.
Make-up water	Water added to a process or a circuit to replace water that is lost by leakage or evaporation for example.
Monitoring	Systematic surveillance of the variations of a certain chemical or physical characteristic of emissions, discharges, consumption, equivalent parameters or technical measures, etc.
Municipal solid waste	Solid waste from households (mixed or separately collected) as well as solid waste from other sources that is comparable to household waste in nature and composition.
New plant	A plant first permitted following the publication of these BAT conclusions or a complete replacement of a plant following the publication of the BAT conclusions for Waste Incineration.

Other non-hazardous waste	Non-hazardous waste that is neither municipal solid waste nor sewage sludge.
Output	The treated material coming out of the waste treatment plant.
Part of an incineration plant	For the purposes of determining the gross electrical efficiency or the gross energy efficiency of an incineration plant, a part of it may refer for example to: <ul style="list-style-type: none"> • an incineration line and its steam system in isolation; • a part of the steam system, connected to one or more boilers, routed to a condensing turbine; • the rest of the same steam system that is used for a different purpose, e.g. the steam is directly exported.
Pasty waste	Non-pumpable waste (e.g. sludge).
Periodic measurement	Measurement at specified time intervals using manual or automated methods.
Periodic sampling	Discrete / individual / separate / discontinuous / grab / spot sampling - individual samples taken in batches or that are time- or effluent-volume-dependent. Three formats can be identified: <ul style="list-style-type: none"> • periodic time-dependent sampling – discrete samples of equal volume are taken at equal time intervals; • periodic flow-proportional sampling – discrete samples of variable volumes are taken at equal time intervals; • periodic samples taken at fixed flow intervals – discrete samples of equal volume are taken after the passage of a constant volume.
Plume	Visible or measurable discharge of a contaminant from a given point of origin, usually a channelled emission from the stack at an industrial site.
Pollution source	The emissions source. Pollution sources can be categorised as: <ul style="list-style-type: none"> • point or concentrated sources; • dispersed sources; • line sources, including mobile (transport) and stationary sources • area sources.
Precision	Refers to the ability of a measurement to be consistently reproduced.
Primary technique	A technique that changes the way in which the core process operates thereby reducing raw emissions or consumption.
Purging	Replacement of the gaseous contents of a system by air or inert gases.
Radioactive material	Radioactive material, as defined in the IAEA Safety Glossary, 2016 Revision.
Recovery	Recovery as defined in Article 3(15) of Directive 2008/98/EC.
Recycling	Recycling as defined in Article 3(17) of Directive 2008/98/EC.
Reuse	Reuse as defined in Article 3(13) of Directive 2008/98/EC.
Reference conditions	Conditions that are specified, e.g. in connection with operating a process, collecting samples.
Regeneration	Treatments and processes mainly designed to make the treated equipment (e.g. activated carbon) or material (e.g. spent solvent) usable again.
Release	Actual discharge (routine, usual or accidental) of emissions into the environment.
Remediation	The containment and/or decontamination of contaminated environmental media such as soil, groundwater, sediment or surface water from a contaminated site intended for further use. The area of the site may be larger than the fenced area.
Reporting	A process of periodic transmission of information about environmental performance, including emissions and compliance with permit conditions, to authorities or to the internal management of the installation and other agencies, such as the general public.
Residues	Any liquid or solid waste which is generated by an incineration plant or by a bottom ash treatment plant.
Run-off	Part of the precipitation and snowmelt that does not infiltrate but moves as overland flow.

Sampling, sample	Sampling is the process by which a portion of substance is collected to form a representative part (the sample) of the whole, for the purpose of examination of the substance or material under consideration. (See also continuous sampling, periodic sampling.)
Sensitive receptor	Area which needs special protection, such as: <ul style="list-style-type: none"> • residential areas; • areas where human activities are carried out (e.g. schools, daycare centres, recreational areas, hospitals or nursing homes).
Sewage sludge	Residual sludge from the storage, handling and treatment of domestic, urban or industrial waste water, except if this residual sludge constitutes hazardous waste.
Slags and/or bottom ashes	Solid residues removed from the furnace once wastes have been incinerated.
Slurry	A suspension of solid particles in a liquid but at a lower concentration than found in a sludge.
Specific emissions/consumption	Emissions/consumption related to a reference basis, such as production capacity, or actual production.
Spot sample	A discrete sample taken at random times and not related to the volume discharged. Also referred to as grab sample.
Standard conditions	Referring to a temperature of 273.15 K, a pressure of 101.325 kPa and a specified oxygen content.
Surrogate parameter	Measurable or calculable quantity which can be closely related, directly or indirectly, to conventional direct measurements of pollutants, and which may therefore be monitored and used instead of the direct pollutant value for some practical purposes. Also called proxy parameter.
Thickening	Liquid-solid separation process to increase the concentration of a suspension by sedimentation, accompanied by the formation of a clear solid.
Unit	A part of the plant in which a specific processing operation is conducted.
Valid half-hourly average	A half-hourly average is considered valid when there is no maintenance or malfunction of the automated measuring system.
Vitrification	The transformation of a substance or a mixture of substances into glass or an amorphous glassy matrix.
Waste	Waste as defined in Article 3(1) of Directive 2008/98/EC.
Waste hierarchy	Priority order in waste prevention and management legislation and policy as stipulated in Article 4 of Directive 2008/98/EC.
Waste holder	Waste holder as defined in Article 3(6) of Directive 2008/98/EC.
Waste input	The incoming waste to be treated in the waste treatment plant.
Waste oil	Waste oil as defined in Article 3(3) of Directive 2008/98/EC.
Waste treatment	Treatment as defined in Article 3(14) of Directive 2008/98/EC.
Zeolites	Microporous aluminosilicate minerals commonly used as commercial adsorbents.

REFERENCES

- [1] UBA, *Draft of a German Report for the creation of a BREF document "waste incineration"*, 2001.
- [2] InfoMil, *Dutch Notes on BAT for the Incineration of Waste*, Information Centre for Environmental Licensing, 2002.
- [3] Austria, *State of the art for waste incineration plants*, 2002.
- [4] IAWG, *municipal solid waste incinerator residues*, Elsevier, 0-444-82563, 1997.
- [5] RVF, *Energy recovery by condensation and heat pumps at WTE plants in Sweden*, 2002.
- [6] EGTEI, *Draft background document on the waste incineration sector*, 2002.
- [7] TWG, *Comments to Draft 1 of the WI BREF*, 2017.
- [8] Energos, *Technical literature regarding Energos Processes*, 2002.
- [9] VDI, 'Thermal waste treatment: state of the art - a summary. (The future of waste treatment in Europe 2002, Strasbourg)', 2002.
- [10] Juniper, *The Market for Pyrolysis and Gasification in Europe*, 1997.
- [11] Assure, *A profile of incineration in Europe (Brussels)*, 2001.
- [12] Achternbosch, *Material flows and investment costs of flue gas cleaning systems of municipal waste incinerators*, Institute for technical chemistry Karlsruhe, Germany, FZKA 6726, 2002.
- [13] JRC(IoE), *NOx and dioxin emissions from waste incineration plants*, EUR 20114 EN, 2001.
- [14] Eurostat, *Waste generation and treatment statistics; data codes: env_wasmun, env_wastrt, env_ww_spd*, 2018.
- [15] Segers, *A new secondary air injection system for MSW plants*, <http://www.scientecmatrix.com/tecma/scientecmatrix.nsf/ffMain?openform&ot=f&oc=waste>, 2002.
- [16] Wilts et al., *Assessment of waste incineration capacity and waste shipments in Europe*, European Topic Centre on Waste and Materials in a Green Economy (ETC/WMGE), 2017.
- [17] ONYX, *Application for IPC permit for EFW plant, Southampton, UK*, 2000. [18] Italy, *DISMO Thermal Oxidation Process*, 2002.
- [19] Babcock, *Water cooled grates*, <http://www.bbpwr.com>, 2002.
- [20] EKOKEM, *BAT Submission by Ekokem, Finland*, 2002.
- [21] FNADE, *Comments provided to TWG on 6 Questions Posed*, 2002.
- [22] Mineur, *Auswirkungen betriebstechnischer optimierungen auf die emissionen bei der verbrunnung van klarschlamm*, VERA Incinerator, Hamburg, 2002.
- [23] VanKessel, *On-line determination of the calorific value of solid fuels*, Elsevier Preprint (submitted), 2002.
- [24] CEFIC, *thermal treatment technologies for waste*, 2002.
- [25] Kommunikemi, *Pre-treatment of packed waste and 3 step flue gas cleaning at KK, DK*, 2002.
- [26] RSP, *Investigations into the efficiency of different flue gas cleaning systems for incineration plants*, Reimann, sunshine and partner GmbH, 1999.
- [27] Belgium, *Flemish experiences with dioxin abatement and control in waste incinerators*, VITO, 2002.
- [28] FEAD et al., 'Energy techniques for municipal waste incinerators- proposed outline, FNADE', Personal Communication, 2002.
- [29] Energy subgroup, *Energy recovery from waste incineration plants - paper*, 2002.
- [30] UBA, *Status report on CO₂ emission saving through improved energy use in plants*, 2002.

- [31] Energy subgroup, 'Personal communication', Personal Communication, 2003.
- [32] Denmark, *Corrosion and inconel cladding*, 2003.
- [33] Finland, *Recovered fuel use in fluid bed combustion and gasification*, VTT Foster Wheeler, 2002.
- [34] ISWA, *Waste-to-Energy, State-of-the-Art-Report*, 2012.
- [35] Renova, 'EIPPCB site visit Sweden / Finland April 2002', Personal Communication, 2002.
- [36] Gohlke, *The SYNCOM plus process, 3-935317-13-1.*, 2002.
- [37] Biollaz, *Better quality MSW residues at lower cost (the PECK process) Incineration 2001*, Brussels, 2001.
- [38] Vehlow, *Bottom ash and APC residue management. Power production from waste and biomass IV*, Helsinki, 951-38-5734-4, 2002.
- [39] Vrancken, *Vergelijking van verwerkingsscenario's voor restfractie van HHA en niet-specifiek categorie II bedrijfsafval*, VITO, 2001.
- [40] EURITS, *List of techniques for consideration as BAT*, 2003.
- [41] EURITS, *Overview of information on Eurits members*, 2002.
- [42] ISWA, *Energy from waste - State of the art report - Jan 2002*, 2002.
- [43] Eunomia, *Costs for municipal waste management in the EU*, 2001.
- [44] RVF, *Energy from waste: an inventory and review of dioxins [in Sweden]*, 2001.
- [45] FEAD, *Emissions of MWI plants for the BREF on waste incineration*, 2002.
- [46] Cleanaway, 'Letter to IPPC Bureau', Personal Communication, 2002.
- [47] TWG, Comments to the pre-final draft of the WI BREF , 2018.
- [48] ISWA., *APC residue management - an overview of important management options*, 2003.
- [49] Denmark, 'Clinical waste at I/S Amagerforbraending, Copenhagen', Personal Communication, 2002.
- [50] CNIM, 'Possible improvements to energy recovery efficiency and their counterparts', Personal Communication, 2003.
- [51] CNIM, 'Energy cycle optimisation - check list for determining local conditions', Personal Communication, 2003.
- [52] Reimann, *Experiences with TMT for mercury minimization in waste water from waste incineration*, 2002.
- [53] Suzuki and Nagayama, 'High efficiency WtE power plant using high-temperature gasifying and direct melting furnace', *Thirteenth International Waste Management and Landfill Symposium*, 2011, Sardinia.
- [54] dechefdebien, 'FGC techniques - proposed outline. CNIM', Personal Communication, 2003.
- [55] EIPPCB, *Site visit reports from EIPPCB*, 2002.
- [56] UKEnvAgency, *Solid residues from municipal waste incinerators in England and Wales*, 2002.
- [57] Alstom, *The NID flue gas cleaning system*, 2003.
- [58] Andersson, *PCDD/F removal from flue gases in wet scrubbers - a novel technique*, 2002.
- [59] CEFIC, *The dry sodium bicarbonate flue gas cleaning process*, 2002.
- [60] Reimann, *De-NOx technologies including a comparison of SCR and SNCR*, 2002.
- [61] SYSAV, 'Selection of SCR for reconstructed process in Malmo', Personal Communication, 2002.

- [62] Tyseley, *Reports for review of operating permit AS9216*, 2001.
- [63] Langenkamp, *Mercury in waste incineration*. JRC, EUR 18978 EN, 1999.
- [64] TWG, TWG Comments on Draft 1 of Waste Incineration BREF, 2003.
- [65] BAFU, *KVA-Rückstände in der Schweiz*, 2010, p. 230.
- [66] UllmansEncyclopaedia, *Encyclopaedia of Industrial Chemistry 6th Edition*, 2001.
- [67] Inspec, Filtration p84, <http://www.p84.com/filter.html>, 2004.
- [68] Ebara, Comments of Ebara on first draft BREF and additional information supplied, 2003.
- [69] Thermoselect, *Information supplied to EIPPCB during site visit*, 2003.
- [70] USEPA, *NOx control technologies applicable to municipal waste combustion*, 1994.
- [71] JRC, *N₂O emissions form waste and biomass to energy plants*, 2003.
- [72] El-Halwagi, *Pollution prevention through process integration, 0-12-236845-2*, 1997.
- [73] Rijkema, *MSWC salt residues; Survey of technologies for treatment*, 2000.
- [74] TWG, TWG Comments on Draft 2 on Waste Incineration BREF, 2004.
- [75] CEN, *EN 13137:2001 Characterization of waste - Determination of total organic carbon (TOC) in waste, sludges and sediments*, 2001.
- [76] CEN, *EN 15169:2007 Characterization of waste - Determination of loss on ignition in waste, sludge and sediments*, 2007.
- [77] ESWET, *BAT candidates: (1) PAC injection upstream or into wet scrubbing systems for Dioxin and Mercury removal, (2) Ringjet Venturi scrubber*, 2015.
- [78] ESWET, *BAT candidate, CFB semi-dry scrubber*, 2015.
- [79] Gass et al., 'PCDD/F- EMISSIONS DURING COLD START-UP AND SHUT-DOWN OF A MUNICIPAL WASTE INCINERATOR', *ORGANOHALOGEN COMPOUNDS*, Vol. Vol. 56 (2002), 2002.
- [80] Denmark, *Long term sampling for mercury as an alternative for AMS*, 2015.
- [81] TWG, Data collection 2016 , 2016.
- [82] Germany, *German proposal on residues treatment*, 2014.
- [83] Dehoust et al. , *Umweltverträglichkeitsstudie der GSB-Anlagen am Standort Baar-Ebenhausen*, Öko-Institut Berlin, Freiburg, Darmstadt, 2005.
- [84] IAF, International Accreditation Forum website, 2010.
- [85] COM, *Best Available Techniques (BAT) Reference Document for Common Waste Water and Waste Gas Treatment/Management Systems in the Chemical Sector (CWW BREF)*, European Commission - JRC IPTS EIPPCB, 2016.
- [86] EU, 'Regulation (EC) No 1221/2009 of the European Parliament and of the Council of 25 November 2009 on the voluntary participation by organisations in a Community eco-management and audit scheme (EMAS), repealing Regulation (EC) No 761/2001 and Commission Decisions 2001/681/EC and 2006/193/EC', *Official Journal of the European Union*, Vol. L 342, 22.12.2009, 2009, pp. 1-45.
- [87] COM, DG Environment: What is Emas? , 2010.
- [88] CEN, *EN ISO 14001:2015 Environmental management systems – Requirements with guidance for use (ISO 14001:2015)*, 2015.
- [89] COM, EMAS reports & statistics.
<http://ec.europa.eu/environment/emas/register/reports/reports.do> , 2015.
- [90] Eurits, *Eurits proposal for BAT Conclusions*, 2016.
- [91] Austria, *BAT Candidate (AT): Syncom (1)*, 2015.
- [92] Denmark, *BAT candidate (DK): Regenerative network braking unit*, 2015.
- [93] Italy, *BAT Candidate (IT): Flameless Pressurized Oxycombustion*, 2015.
- [94] Finland, *FI4-1_WIQ_02_BAT_candidate_External_superheater_Oulun_Energia*, 2016.
- [95] ESWET, - *LT-SCR - Explosion Cleaning - VLN*, 2015.

- [96] Italy, *BAT candidate (IT): Water Blowdown Recovery / Magnesium Lime Injection*, 2016.
- [97] Denmark et al., *BAT Candidate (DK, SE): Flue gas polishing (cleaning) of flue gases by means of scrubber technique*, 2015.
- [98] Belgium, *BE-Flemish BAT study on treatment of bottom ashes from MSW incineration*, 2016.
- [99] EuLA, *BAT candidate (EuLA): Co injection of hydrated lime and sodium bicarbonate*, 2015.
- [100] EuLA, *BAT candidate (EuLA): 3/4 Dry FGC process*, 2015.
- [101] Sweden, *BAT candidate (SE): Ammonia stripper on flue-gas condensate*, 2016.
- [102] CEFIC, *BAT Candidate: Gore De NO_x catalytic bag filtration*, 2015.
- [103] Denmark, *BAT candidate (DK) - Waste water treatment adsorption of heavy metals*, 2016.
- [104] Denmark, *DK BAT candidate Sorting slag for recyclable metals*, 2015.
- [105] Netherlands, *NL3-5 02_IBA treatment questionnaire HVC Dordrecht Annex 1 ACKK332016*, 2016.
- [106] HWE, *BAT candidate (HWE): SNCR NO_x Abatement by injection of granular urea*, 2015.
- [107] Austria, *AT - Candidate BAT: IBA*, 2015.
- [108] Sweden, *BAT Candidate (SE03): High-efficiency SNCR with advanced temperature measurement*, 2016.
- [109] Sweden, *BAT Candidate (SE): ADIOX for dioxin removal in wet scrubbers and semi-wet- or dry absorbers*, 2016.
- [110] COM, *Best Available Techniques (BAT) Reference Document for Large Combustion Plants (LCP BREF)*, European Commission - JRC IPTS EIPPCB, 2017.
- [111] Germany, *BAT candidate (DE29): NET floc SMF Technology*, 2016.
- [112] EEB, *BAT candidate (EEB): Separate injection of AC, controlled by a continuous mercury monitoring in the raw gas*, 2015.
- [113] Sweden, *Candidate BAT (SE): Mercox*, 2015.
- [114] Wilken et al., 'START-UP OF A HAZARDOUS WASTE INCINERATOR – IMPACT ON THE PCDD/PCDF-EMISSIONS', *Organohalogen Compounds*, Vol. Volumes 60-65, Dioxin 2003, 2003.
- [115] Vosteen et al., 'Bromine-enhanced Mercury Abatement from Combustion Flue Gases ', 2015.
- [116] van den Berg et al., 'Polybrominated Dibenzo-p-Dioxins, Dibenzofurans, and Biphenyls: Inclusion in the Toxicity Equivalency Factor Concept for Dioxin-Like Compounds', Vol. 133 (2), 2013, p. 197–208.
- [117] COM, *JRC Reference Report on Monitoring of Emissions to Air and Water from IED installations (ROM REF)*, European Commission, JRC IPTS EIPPCB, 2018.
- [118] INERIS, *Study on AMS and SRM performances and their impact on the feasibility of lowering ELVs for air emissions in the context of the BREFs and BATs revision and of BATAELs elaboration according to the IED*, Institut National de l'Environnement Industriel et des Risques, 2016.
- [119] EEB, *Candidate BAT (EEB): Hg and SO₂ air emissions control by GORE Sorbent Polymer Catalyst*, 2015.
- [120] Smith et al., 'INNOVATIVE TECHNOLOGY REDUCES MERCURY EMISSIONS TO KEEP OHIO'S SEWAGE SLUDGE INCINERATORS HOT AND COSTS COOL The Road to SSI MACT Compliance for Cincinnati and Cleveland', 2017.
- [121] INERIS, *Study of the performances of existing and under development AMSs (Automated Measuring Systems) and SRMs (Standard Reference Methods) for air emissions at the level of and below existing ELVs (Emission Limit Values) and BATAELs (Best Available Techniques Associated Emission Levels) for Waste Incineration, Co-incineration and Large Combustion Plants*, INERIS, 2017.

- [122] COM, *Reference Document on the Best Available Techniques for Waste Incineration*, European Commission, JRC IPTS EIPPCB , 2006.
- [123] FDBR, *Guideline RL 7: Acceptance Testing of Waste Incineration Plants with Grate Firing Systems*, FDBR, 2013.
- [124] Beckmann et al., 'Online Determination of Elementary and Fractional Waste Composition for Municipal Solid Waste Incineration Plants', *WASTE MANAGEMENT*, Vol. Volume 7 Waste-to-Energy, 2017.
- [125] Pohl and Wen, *Assistenzsysteme in Kraftwerken - Handlungsempfehlungen auf Grundlage der modellbasierten Daten und Prozessanalyse*, Dampferzeugerkorrosion 2017: Betrieb und Instandhaltung 4.0, Freiberg: Saxonia , 2017.
- [126] EIPPCB, *Report of the 2017 site visits in Germany*, 2017.
- [127] EIPPCB, *Report of the 2017 site visits in France*, 2017.
- [128] Löthgren et al., 'Mercury Speciation in Flue Gases after an Oxidative Acid Wet Scrubber', *Chem. Eng. Technol.*, Vol. 30, No. 1, 2007, p. 131–138.
- [129] Andersson and Paur, Mercury reduction by the MercOx process, Description of project EU Life99 ENV/S/000626, 2005.
- [130] Martin and Hanenkamp, 'Thermo-Recycling', *Waste Management*, Vol. Vol 7 Waste-to-Energy, 2017.
- [131] Magaldi, Project Experience, high-performance conveyors, n.16, 2017.
- [132] Stultz et al., 'US Patent US5174865A: Process for purifying crude hydrochloric acid ', 1992.
- [133] ADEME, *Bottom ash management facilities for treatment and stabilisation of incineration bottom ash*, ADEME, 2002.
- [134] EdDE, *Dokumentation 17: Metallrückgewinnung aus Rostaschen aus Abfallverbrennungsanlagen - Bewertung der Ressourceneffizienz*, EdDE, 2015.
- [135] Belgium, Belgian data on PCDD/F emissions measured with long-term sampling , 2018.
- [136] SVDU-FNADE, French Comparative data on PCDD/F emission measurements performed with short-term and long-term sampling , 2018.
- [137] HWE, PCDD/F emission measurements by long-term sampling in HWI , 2018.
- [138] Bezak-Mazur et al., 'Phosphorus speciation in sewage sludge', *Environment Protection Engineering*, Vol. 40 (3), 2014, pp. 161 - 175.
- [139] Kleemann et al., 'Comparison of phosphorus recovery from incinerated sewage sludge ash (ISSA) and pyrolysed sewage sludge char (PSSC)', *Waste Management*, Vol. 60, 2017, pp. 201 - 210.
- [140] Biswas et al., 'Leaching of phosphorus from incinerated sewage sludge ash by means of acid extraction followed by adsorption on orange waste gel', *Journal of Environmental Sciences*, Vol. 21 (12), 2009, pp. 1753 - 1760.
- [141] Egle et al., 'Phosphorus recovery from municipal wastewater: An integrated comparative technological, environmental and economic assessment of P recovery technologies', *Science of The Total Environment*, Vol. 571, 2016, pp. 522 - 542.
- [142] Amann et al., 'Environmental impacts of phosphorus recovery from municipal wastewater', *Resources, Conservation and Recycling*, Vol. 130, 2018, pp. 127 - 139.
- [143] Healy et al., 'Resource recovery from sludge', *Sewage treatment plants: economic evaluation of innovative technologies for energy efficiency*, 2015.
- [144] Energy subgroup, *Example of an intermediate case CHP plant for the review of the WI BREF*, 2019.
- [145] Easymining , Project site , 2019.
- [146] Phos4you, Acid extraction of phosphorus from sewage sludge incineration ash: REMONDIS TetraPhos, 2019.
- [147] Langeveld and Ten Wolde, 'Phosphate recycling in mineral fertiliser production', *Proceedings of the International Fertiliser Society*, Vol. 727, 2014, pp. 1 - 24.

References

- [148] Scheidig, 'Economic and energy aspects of phosphorus recycling from sewage sludge', *Korrespondenz Abwasser Abfall*, Vol. 56, 2009, pp. 1138 - 1146.
- [149] Schönberg et al., 'The recophos process: recovering phosphorus from sewage', *Österreichische Wasser- und Abfallwirtschaft*, Vol. 66, 2014, pp. 403 - 407.
- [150] Huygens et al., *Technical proposals for selected new fertilising materials under the Fertilising Products Regulation (Regulation (EU) 2019/1009) - Process and quality criteria, and assessment of environmental and market impacts for precipitated phosphate salts & derivatives, thermal oxidation materials & derivatives and pyrolysis & gasification materials*, European Commission, Joint Research Centre, 2019.
- [151] AEB Amsterdam, *Annual report*, 2017, p. Page 28.
- [152] AEB Amsterdam, *Value from Waste*, 2007, pp. Pages 12-14.

GETTING IN TOUCH WITH THE EU

In person

All over the European Union there are hundreds of Europe Direct information centres. You can find the address of the centre nearest you at: https://europa.eu/european-union/contact_en

On the phone or by email

Europe Direct is a service that answers your questions about the European Union. You can contact this service:

- by freephone: 00 800 6 7 8 9 10 11 (certain operators may charge for these calls),
- at the following standard number: +32 22999696, or
- by electronic mail via: https://europa.eu/european-union/contact_en

FINDING INFORMATION ABOUT THE EU

Online

Information about the European Union in all the official languages of the EU is available on the Europa website at:

https://europa.eu/european-union/index_en

EU publications

You can download or order free and priced EU publications from EU Bookshop at: <https://publications.europa.eu/en/publications>.

Multiple copies of free publications may be obtained by contacting Europe Direct or your local information centre (see https://europa.eu/european-union/contact_en).

The European Commission's science and knowledge service

Joint Research Centre

JRC Mission

As the science and knowledge service of the European Commission, the Joint Research Centre's mission is to support EU policies with independent evidence throughout the whole policy cycle.



EU Science Hub

ec.europa.eu/jrc



@EU_ScienceHub



EU Science Hub - Joint Research Centre



Joint Research Centre



EU Science Hub



Publications Office

doi: 10.2760/761437
ISBN 978-92-76-12993-6