

---

European Organisation for Technical Approvals  
Europäische Organisation für Technische Zulassungen  
Organisation Européenne pour l'Agrément Technique

---

red. Anm. Derzeit nicht in deutscher Fassung verfügbar

**ETAG 001**  
Edition 2012

GUIDELINE FOR EUROPEAN TECHNICAL APPROVAL  
OF  
**METAL ANCHORS**  
**FOR USE IN CONCRETE**

**Annex E: ASSESSMENT OF METAL ANCHORS  
UNDER SEISMIC ACTION**  
April 2013

EOTA  
Avenue des Arts 40 Kunstlaan  
B – 1040 Brussels

## TABLE OF CONTENTS

### ANNEX E

#### Tables

Table 1.1	Minimum recommended performance categories for anchors under seismic actions
Table 2.1	Additional tests for qualification of anchors under category C1
Table 2.2	Required loading history for test series C1.1
Table 2.3	Required loading history for test series C1.2
Table 2.4	Additional tests for qualification of anchors under category C2
Table 2.5	Required load amplitudes for test series C2.3
Table 2.6	Required load amplitudes for test series C2.4
Table 2.7	Required crack widths for test series C2.5
Table 3.1	Displacement information
Table 3.2	Sample ETA seismic design information for seismic performance category C1
Table 3.3	Sample ETA seismic design information for seismic performance category C2

#### Figures

Figure 2.1	Example cross section of test member
Figure 2.2	Example for test member with bond breaking pipes on rebar (plan view)
Figure 2.3	Measurements to show fulfillment of the constant crack width requirement
Figure 2.4	Effective load transfer zone
Figure 2.5	Sketch of example for shear test setup with no significant friction forces
Figure 2.6	Required loading history for test series C1.1
Figure 2.7	Required load history for test series C1.2
Figure 2.8	Permitted approximation of seismic shear cycle C1.2
Figure 2.9	Schematic test procedure C2.3
Figure 2.10	Schematic test procedure C2.4
Figure 2.11	Permitted seismic shear cycle C2.4
Figure 2.12	Schematic test procedure C2.5

## 1 Scope

This annex covers metal anchors for use in concrete under seismic actions. The assessment of metal anchors under seismic actions (ETAG 001 Annex E) is optional. The annex deals with the preconditions, assumptions, required tests and assessment for metal anchors under seismic actions. Anchors qualified for multiple use for non-structural applications according to ETAG 001, Part 6 are not covered by this document.

This annex does not address the use of anchors under fatigue loads and/or impact loads.

### 1.1 General

The tests in this annex are intended to evaluate the performance of anchors under simulated seismic tension and shear loading, including the effects of cracks, and under simulated seismic crack cycling conditions. The behaviour of anchors in regions of reinforced concrete structures, where plastic steel strains are expected (e.g. in plastic hinge zones) is not covered in the requirements of this annex; anchors shall be placed outside of these regions.

A precondition for qualification in anchor seismic performance categories C1 and C2 is the complete assessment according to ETAG 001 Part 1 to 5 for use in cracked and non-cracked concrete (option 1 to 6).

The compressive strength of concrete  $f_{c,test}$  used in the various equations in this document shall consistently represent the value measured with standard cylinders or standard cubes (see ETAG 001, Annex A), unless specifically required otherwise. If necessary the concrete compressive strength may be converted according to ETAG 001, Annex A, 2.4.

### 1.2 Categories

For the evaluation of the performance of anchors subjected to seismic loading two seismic performance categories, i.e. C1 and C2, with C2 being more stringent than C1, are distinguished.

Performance category C1 provides anchor capacities in terms of strength (forces), while performance category C2 provides anchor capacities in terms of both strength (forces) and deformations. In both cases, the effect of concrete cracking is taken into account. The maximum crack width considered in C1 is  $w = 0,5$  mm and in C2 it is  $w = 0,8$  mm, where  $w$  is additive to the hairline crack width in the concrete member after anchor installation but before anchor loading.

Qualification of anchors for category C1 comprises tests under pulsating tension load (2.3.1) and tests under alternating shear load (2.3.2). Qualification of anchors for category C2 includes reference tests up to failure (2.4.2), tests under pulsating tension load (2.4.3), tests under alternating shear load (2.4.4) as well as tests under crack cycling (2.4.5). In these tests forces and displacements are measured either continuously or at certain intervals. Qualification of anchors for category C2 places higher demands on the performance of anchors under seismic action as compared to category C1.

Based on the respective load histories and crack widths, which are different for the two categories C1 and C2, the design information for C1 contains values of tension and shear resistance of the anchor, while for C2 it contains values of tension and shear resistance as well as anchor displacement.

Detailed information regarding the various testing protocols and assessment criteria for both seismic performance categories is given in Chapters 2 and 3.

*The recommended use of the performance categories C1 and C2 as they relate to the design of fastenings are described in the following. Table 1.1 relates the anchor seismic performance categories C1 and C2 to the*

- *seismicity, and*
- *building importance class.*

*The designer shall use Table 1.1 to select an anchor with the appropriate seismic qualification for the application under consideration. Table 1.1 defines minimum recommended seismic performance categories, C2 being the more stringent one, according to the ground acceleration in accordance with EN 1998-1:2004: Eurocode 8 (EC 8) [1].*

*The decision of the selection of a higher seismic performance category than given in Table 1.1 is in the responsibility of each individual Member State.*

Furthermore, the values of  $a_g \cdot S$  assigned to the seismicity levels may be different in the National Annexes to EC 8 compared to the values given in Table 1.1.

**Table 1.1 Minimum recommended performance categories for anchors under seismic actions**

Seismicity		Importance Class acc. to EN 1998-1:2004, 4.2.5			
		I	II	III	IV
	$a_g \cdot S^2)$				
Very low <sup>1)</sup>	$a_g \cdot S \leq 0,05 g$	ETAG 001 Part 1 to Part 5			
Low <sup>1)</sup>	$0,05 g < a_g \cdot S \leq 0,1 g$	C1	C1 <sup>3)</sup> or C2 <sup>4)</sup>		C2
	$a_g \cdot S > 0,1 g$	C1	C2		

<sup>1)</sup> Definition according to EN 1998-1:2004, 3.2.1.

<sup>2)</sup>  $a_g = \alpha_1 \cdot a_{gR}$  Design ground acceleration on type A ground (Ground types as defined in EN 1998-1:2004, Table 3.1);

$\alpha_1 =$  importance factor (see EN 1998-1:2004, 4.2.5);

$a_{gR} =$  reference peak ground acceleration on type A ground (see EN 1998-1:2004, 3.2.1);

$S =$  Soil factor (see e.g. EN 1998-1:2004, 3.2.2).

<sup>3)</sup> C1 for fixing non-structural elements to structures

<sup>4)</sup> C2 for fixing structural elements to structures

## 2 Methods of Verification

### 2.1 General testing requirements

As far as applicable ETAG 001 Part 1 "General" and Annex A "Details of test" shall be followed for test members, test setup and details of tests. Modifications are addressed in 2, which overrule conflicting provisions in ETAG 001 Annex A.

#### 2.1.1 Test members

In general, the test members shall comply with ETAG 001 Annex A, 2.

The thickness of the test member shall be at least the maximum of  $1,5 h_{ef}$  and the minimum member thickness requested by the manufacturer which is given in the ETA. The width of the test member shall be large enough to avoid any influence of the edges on the anchor behaviour. The test member shall be designed such that the crack width is approximately constant throughout the thickness of the test member during the test (including crack cycling (for crack widths  $\leq 0,3$  mm), load cycling and peak load). This requirement is considered to be fulfilled if

a) the crack width  $w_{hef}$  at the level of the embedment depth  $h_{ef}$  is equal to or greater than the required value, and

b) the crack width  $w_{top}$  at the top side of the test member (i.e. the side in which the anchor is installed) is equal to or larger than  $w_{hef}$  for  $w_{hef} \leq 0,3$  mm.

The reinforcement shall be of equal size and placed symmetrically (see Figure 2.1). The spacing of the reinforcement in the test member shall be  $\leq 400$  mm. The capacity of the anchor shall not be affected by the reinforcement. The reinforcement shall remain well in the elastic range during each test. Buckling of the reinforcement shall be avoided. The bond length  $\ell_b$  between possible crack planes and at both ends of the specimen (see Figure 2.2) shall be large enough to introduce the tension force into the concrete.

To facilitate the opening of the crack by  $w = 0,8$  mm a bond breaker may be applied at both sides of the crack (see Figure 2.2). A plastic pipe with an inner diameter of  $\geq 1,2 d_s$  may be used for this purpose, where  $d_s$  denotes the diameter of the reinforcing bar. When using bond breakers the de-bonding length  $\ell_{db}$  is recommended to be  $\geq 5d_s$ .

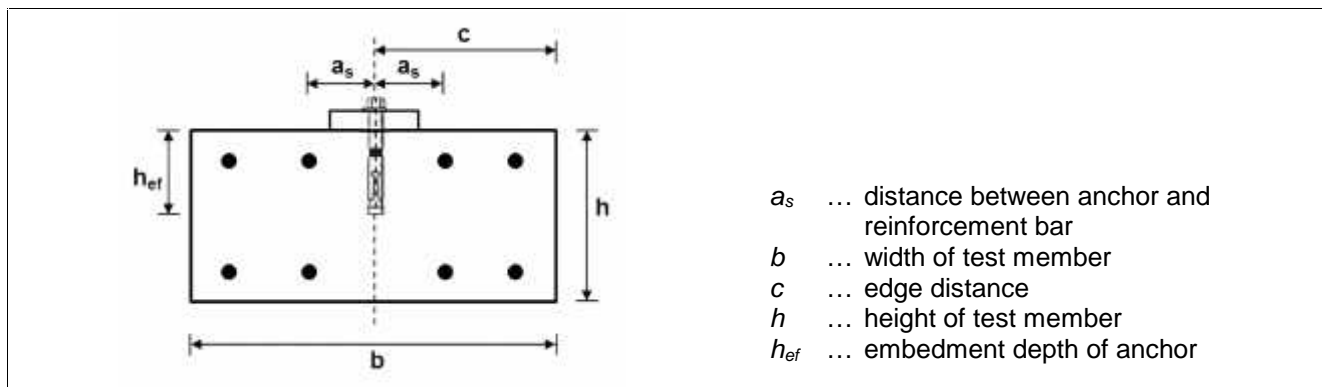

Figure 2.1 Example cross section of test member

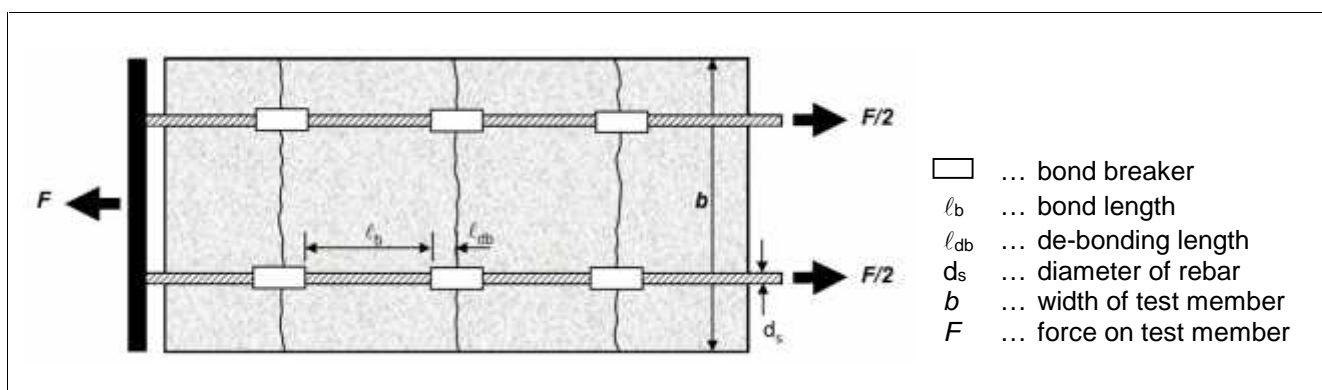

Figure 2.2 Example for test member with bond breaking pipes on rebar (plan view)

The requirement that the anchor behaviour is not influenced by the edges of the test member is considered to be fulfilled if for unconfined testing the concrete breakout body does not intersect with an edge or the edge distance of the anchor in all directions is  $c \geq 2h_{ef}$ .

The requirement that the capacity of the anchor is not affected by the reinforcement is considered to be fulfilled for unconfined tests if the distance  $a_s$  between the anchor and the nearest reinforcement bar (see Figure 2.1) is at least 75 mm and  $0,60 h_{ef}$ . If for large embedment depths this distance requirement and the spacing requirement of the reinforcement  $400 \text{ mm}$  cannot be fulfilled at the same time an expertise is required showing that the nearest reinforcement bar does not affect the capacity of the anchor.

For confined tests the distance requirements between anchor and nearest reinforcement as stated in the previous paragraph do not apply.

*Note: The above requirement for  $a_s$  is based on the consideration that the reinforcement does not intersect the portion of the concrete breakout cone that has developed at peak load and the following two assumptions:*

1. *The crack length at ultimate load is approximately 0,4 times the side length of the final cone. The slope of the cone as measured from the horizontal is on the average about  $35^\circ$ .*
2. *The spacing of the reinforcement used to create and control the crack width is typically not less than 150 mm.*

The above requirements regarding the constant crack width may be considered to be fulfilled if all of the following conditions are met:

1. The thickness  $h$  and the width  $b$  of the test member are  $h \geq 2h_{ef}$  and  $b \geq 4h_{ef}$ , respectively.

2. The reinforcement ratio  $\rho = A_{s,re}/A_{c,ref} \leq 0,01$ ,

where:

$A_{s,re}$  = total cross section area of top and bottom reinforcement of the test member,  
 $A_{c,ref}$  = reference cross section area of concrete for calculation of reinforcement ratio  
 $= b_{ref} \cdot h_{ref}$ , with  $b_{ref} = 4h_{ef} \geq 400 \text{ mm}$  and  $h_{ref} = 2 h_{ef} \geq 200 \text{ mm}$ .

3. The reinforcement is of equal size arranged in one layer each at the top and bottom side. The concrete cover for the reinforcement is approximately  $2d_s$ . The spacing of the reinforcement is  $400 \text{ mm}$ . The distance  $a_s$  between the anchor and the nearest reinforcement bar is larger than defined above.

4. The de-bonding length of the reinforcement (see Figure 2.2) is  $\ell_{db} = 1,0 d_s$  (support of the anchor tension load in one direction) or  $\ell_{db} = 3d_s$  (support of anchor tension load in two directions, i.e. round or square support).
5. The yield strength of the reinforcement is  $f_{yk} = 800 \text{ N/mm}^2$  when using  $\ell_{db} = 3d_s$  or  $f_{yk} = 1000 \text{ N/mm}^2$  when using  $\ell_{db} = 1,0 d_s$  to ensure that the reinforcement remains well in the elastic range during each test.

If these conditions are not met, the fulfilment of the requirements regarding the constant crack width shall be demonstrated for each test member design for the anchor with the highest ultimate load to be tested in this test member for the crack width required for the specific test (see Table 2.1 and Table 2.4) and for crack width  $w = 0,3 \text{ mm}$  to  $0,8 \text{ mm}$  for test series C2.5. At least 3 test members shall be tested for each test member design and in each test the conditions given above shall be fulfilled. The results of this verification shall be reported in the test report. There are two options for the verification shown in Figure 2.3a) and Figure 2.3b).

According to Figure 2.3a) the crack widths are measured at the top and bottom of the test member either at the anchor location (locations 1 and 2 in Figure 2.3a) or at a distance of approximately  $h_{ef}$  on both sides of the anchor (locations 3 & 4 and 5 & 6 in Figure 2.3a). The mean value of the crack width measurements at locations 3 and 4 represents  $w_{top}$  and the mean value of the crack width measurements at locations 5 and 6 represents  $w_{bottom}$ . The crack width  $w_{hef}$  is obtained by linear interpolation of the top and bottom crack widths, i.e.  $w_{top}$  and  $w_{bottom}$ , respectively.

Alternatively, the approach shown in Figure 2.3b) may be pursued if it is shown that the width of the crack remains approximately constant across the width of the test member. This condition is considered to be fulfilled if the ratio of the mean value of the crack width measurements at locations 7 and 8 to the mean value of the measurements at locations 3 and 4 is  $\leq 1,05$ . The mean value of the crack width measurements at locations 3 and 4 represents  $w_{top}$  and the mean value of the crack width measurements at locations 9 and 10 represents  $w_{hef}$ .

For test series C2.5 only one anchor shall be located in a crack at the time of testing.

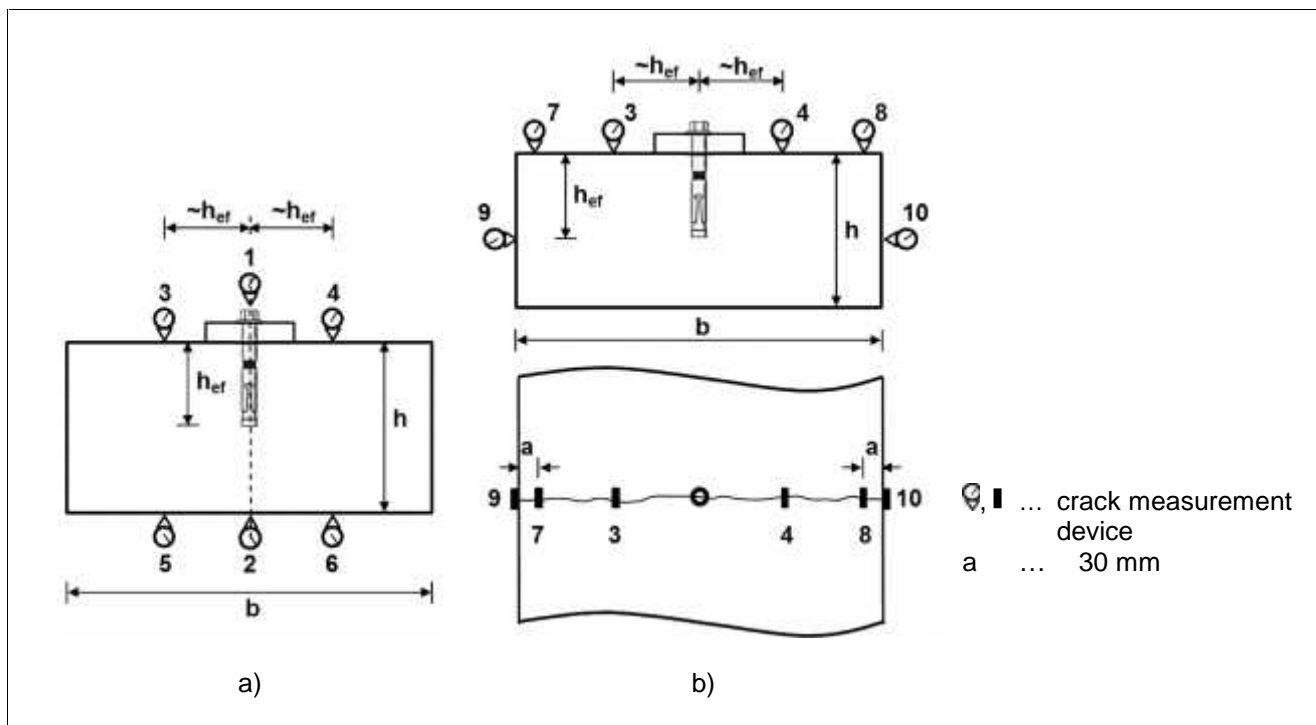

**Figure 2.3 Measurements to show fulfillment of the constant crack width requirement**

### 2.1.2 Installation of anchors

Install the anchor in a hairline crack according to ETAG 001 Annex A, 3 and the manufacturer's printed installation instructions except for tests described in 2.4.5, where a compression load is applied to the test member before installation of the anchor. Use drill bits with a diameter  $d_{cut,m}$  (mean). If no torque is specified by the manufacturer's printed installation instructions, finger-tighten the anchor prior to testing. Test internally threaded anchors with the bolt specified by the manufacturer and report the bolt type in the test report.

### 2.1.3 Crack measurement and tolerance on crack width

The crack width shall be measured continuously during the test with a measuring error not greater than 0,02 mm.

In tension tests the crack width  $w_{hef}$  shall be determined by either one of the following two approaches:

- Linear interpolation of crack measurements at the top  $w_{top}$  and bottom  $w_{bottom}$  of the test member (see Figure 2.3a). In this case the crack width shall be measured either at the location of the anchor (i.e. locations 1 ( $w_{top}$ ) and 2 ( $w_{bottom}$ ) in Figure 2.3a) or on both sides of the anchor (i.e. locations 3 & 4 (for  $w_{top}$ ) and 5 & 6 (for  $w_{bottom}$ ) in Figure 2.3a) with the two mean values of the measurements at the top and bottom representing  $w_{top}$  and  $w_{bottom}$ , respectively.
- Measuring the crack width at the side of the test member at the embedment depth level  $h_{ef}$  (i.e. locations 9 & 10 in Figure 2.3b). In this case the mean value of the measurements at the side of the test member shall be determined to represent  $w_{hef}$ .

For both approaches in unconfined tension tests the measurement devices shall be placed as shown in Figure 2.3. In confined tension tests the measuring devices 3, 4, 5 and 6 in Figure 2.3a and 3 & 4 in Figure 2.3b shall be placed as close as possible to the anchor but not further away than 150 mm from the anchor.

In shear tests the crack width shall be measured within a distance of approximately  $1,0 h_{ef}$  in front of and behind the anchor (and the mean value is determined) or directly at the anchor location where possible.

The mean of the measured crack widths  $w_{hef}$  for each test series determined for each anchor shall be equal to or greater than the specified crack width for the test series. Individual crack widths shall be within the following tolerance:

- for  $w < 0,3$  mm: 20% of crack width specified for the test series
- for  $w \geq 0,3$  mm: minimum of 10% of the crack width specified for the test series and 0,04 mm.

### 2.1.4 Test setup

The anchor shall be located in the crack over the entire effective load transfer zone,  $h_{ltz}$ , of the anchor (meaning, e.g. over the entire embedment depth for a bonded anchor or a concrete screw, over 1,5 times the length of the interaction zone  $h_{iz}$  of a torque-controlled expansion anchor or undercut anchor or bonded expansion anchor, see Figure 2.4).

*Note: One way to achieve this, at least for larger anchor diameters, is to drill the anchor hole at the desired position prior to initiating the cracking.*

It shall be verified that the anchor is located in the crack over the length defined above, e.g. by use of a borescope.

All tension tests shall be performed as unconfined tests according to ETAG 001 Annex A unless specified otherwise in the specific test section below.

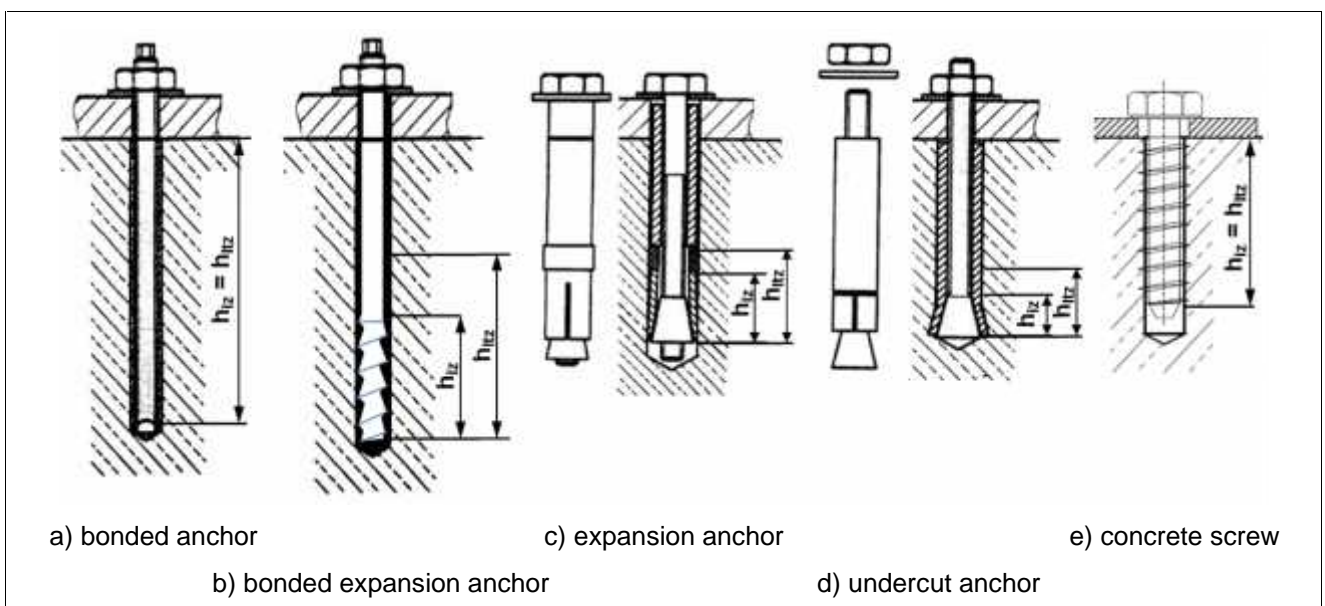
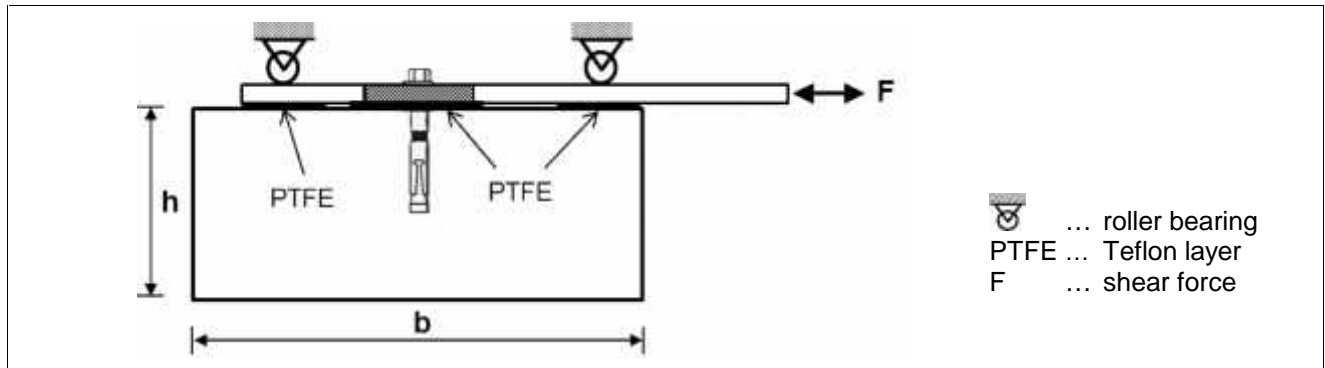

Figure 2.4 Effective load transfer zone

In shear tests uplift of the fixture (steel plate) shall be restrained such that no significant friction forces are induced. Such friction forces are avoided if for example a setup as shown in Figure 2.5 is used, which prevents the uplift, limits friction by roller bearing and does not actively apply a compression force. Furthermore, the maximum allowed annular gap of the clearance hole (see ETAG 001 Annex A, Table 4.1) shall be selected in the shear tests. For anchors with a specified smaller gap or without an annular gap, both of which have to be stated in the ETA, the specific anchor system may be tested.



**Figure 2.5 Sketch of example for shear test setup with no significant friction forces**

All tests with bonded anchors shall be performed at normal ambient temperature ( $21^{\circ}\text{C} \pm 3^{\circ}\text{C}$ ).

*Note: The effect of high loading rates on the anchor behaviour is conservatively neglected.*

### 2.1.5 Control of crack width

In the tests to failure (monotonic tests and residual capacity tests) the anchor is subjected to load while the crack width as defined in 2.1.3 is controlled, either

- at a constant width taking into account the requirements given in section 2.1.1, for example, by means of a servo system, or
- limited to a width close to the specified value by means of appropriate reinforcement and test member dimensions (see 2.1.1).

## 2.2 Anchor types to be tested

In general, the tests described in 2.3 and 2.4 shall be performed with all anchor diameters, embedment depths, steel types (galvanised steel, stainless steel, high corrosion resistant steel) and grades (strength classes), production methods, head configurations (mechanical anchors), types of inserts (threaded rod, threaded sleeve or rebar for bonded anchors) as well as drilling methods to be qualified for use in seismic applications. The number of variants to be tested may be reduced as described below. It shall be allowed to perform additional tests beyond the minimum number of tests described below to verify anchor characteristics for additional parameters (e.g. tests at different embedment depths).

If certain reference tension tests, which are required in the context of this assessment, have not been performed in the non-seismic part of the prequalification, these tests shall be performed. Alternatively, it shall be permitted that the corresponding resistance under ultimate load is calculated from the data obtained in the non-seismic prequalification for cracked concrete.

### 2.2.1 Torque controlled expansion anchors

#### 2.2.1.1 Steel type, steel grade and production methods

##### 2.2.1.1.1 Tension tests

If all of the following conditions are fulfilled, and the eventual reduction factor is accepted for all anchors, only anchors of one steel type, the highest steel grade and one production method need to be tested. Otherwise anchors of all steel types, steel grades and production methods shall be tested. Meaning, if all conditions are fulfilled for all steel types and steel grades but not for different production methods, then anchors of different production methods shall be tested.

- The geometry of the anchor is identical.
- The pre-stressing forces at torque  $T = 0,5 T_{inst}$  as well as at  $T = 1,0 T_{inst}$  are statistically equivalent for the different steel types, steel grades and production methods. The installation torque  $T_{inst}$  may be different for different steel types and steel grades.



- c) The friction between cone and sleeve (internal friction) and the friction between sleeve and concrete (external friction) are identical for the different steel types, steel grades and production methods. This condition shall be considered to be fulfilled if the anchors are made out of the same material, and any coatings are the same, and the surface roughness and hardness of the cone and the sleeve are statistically equivalent. For anchors made out of different materials (e.g. galvanized and corrosion resistant steel) this condition shall be considered to be fulfilled if the coating is identical, and the internal friction between cone and sleeve depends mainly on the coating, and the surface roughness and hardness of the cone and the sleeve are statistically equivalent.

The measured displacements shall be applied to the anchors made from other steel types, steel grades or by other production methods.

#### **2.2.1.1.2 Shear tests**

Only anchors made of galvanized steel of the highest grade and lowest rupture elongation (percentage of elongation after fracture, A, see ISO 898-1 [3]) need to be tested if the reduction of the characteristic steel shear resistance due to simulated seismic shear testing as compared to the characteristic steel shear resistance under static loading is accepted for all steel types and steel grades. Otherwise all steel types and steel grades shall be tested. The measured displacements shall be applied to the anchors made from other steel types, steel grades or by other production methods.

#### **2.2.1.2 Head configuration**

The specific test series shall be performed with the most adverse head configuration of the product in respect to functioning and ultimate load. If the most adverse head configuration is not obvious all head configurations shall be tested.

#### **2.2.1.3 Embedment depth**

##### **2.2.1.3.1 Tension tests**

- a) Anchors under category C1 (test series C1.1):  
If multiple embedment depths are specified, in general, minimum and maximum embedment depths shall be tested. However, only the maximum embedment depth needs to be tested if the reduction factor for seismic loading  $r_{N,seis,C1}$  according to Equation (3.1) is accepted for all embedment depths.
- b) Anchors under category C2 (test series C2.1, C2.3 and C2.5):  
If multiple embedment depths are specified, it is allowed to only perform tests at the maximum embedment depth. If only the maximum embedment depth is tested, the reduction factors  $r_{N,seis,C2}$  and  $S_{CV,N,C2}$  according to Equation (3.48) and Equation (3.49), respectively, for the maximum embedment depth shall be applied to anchors with shallower embedment depths and the displacements measured for anchors with the maximum embedment shall be applied to anchors with shallower embedment depths.

##### **2.2.1.3.2 Shear tests**

- a) Anchors under category C1  
If there is more than one embedment depth specified for an anchor diameter, tests need to be performed for the minimum and maximum embedment depth only. If in the tests with minimum embedment depth steel failure occurs tests at the maximum embedment depth may be omitted if the reduction factor  $r_{V,seis,C1}$  according to Equation (3.2) is applied to all embedment depths.
- b) Anchors under category C2  
Only the minimum embedment depth needs to be tested if the reduction factor for seismic loading  $r_{V,seis,C2}$  according to Equation (3.50) is accepted for all embedment depths. If at the minimum embedment depth pryout failure is encountered, select a larger embedment depth avoiding pryout failure. The displacements measured in the tests with the minimum embedment depth shall be applied to anchors with a larger embedment depth.

#### **2.2.1.4 Drilling method**

A reduction of number of drilling methods to be tested is only allowed for shear tests. In this case the hole shall be drilled with the most adverse drilling method, which in many cases will be core drilling.

## **2.2.2 Undercut anchors (not including concrete screws)**

### **2.2.2.1 Steel type, steel grade and production method**

#### **2.2.2.1.1 Tension tests**

If the undercut of the concrete is identical in all models for full expansion and partial expansion during the installation safety tests (ETAG 001 Part 3, 5.1.2.1), only anchors of one steel type, the highest steel grade and one production method need to be tested. The measured displacements shall be applied to all steel types, steel grades and production methods. If this condition is not fulfilled, test all anchors; however, only anchors with the minimum undercut for full expansion need to be tested if the reduction factor due to simulated seismic tension testing  $N_{seis,C1}$  according to Equation (3.1) and  $N_{seis,C2}$  and  $S_{cv,N,C2}$  according to Equation (3.48) and Equation (3.49), respectively, are accepted for all anchors.

In addition, an undercut anchor that shows a follow-up expansion during loading shall comply with the requirements for torque-controlled expansion anchors in 2.2.1.1.1.

#### **2.2.2.1.2 Shear tests**

See 2.2.1.1.2.

### **2.2.2.2 Head configuration**

See 2.2.1.2.

### **2.2.2.3 Embedment depth**

See 2.2.1.3.

### **2.2.2.4 Drilling method**

See 2.2.1.4.

## **2.2.3 Concrete screws**

A reduction of number of variants to be tested is only allowed for shear tests with respect to the embedment depth as given in 2.2.1.3.2 and the drilling method as given in 2.2.1.4.

## **2.2.4 Bonded anchors**

### **2.2.4.1 Type of insert**

#### **2.2.4.1.1 Tension tests:**

If the bond strength is equal for bonded anchors with different types of inserts (threaded rod, rebar, internal threaded sleeve etc.) tests can be performed with the most adverse type of insert and the results shall be applied to all other types of inserts. If the bond strength is different, all types of inserts shall be tested.

#### **2.2.4.1.2 Shear tests:**

No reduction of number of variants to be tested is allowed.

### **2.2.4.2 Steel type, steel grade and production method**

#### **2.2.4.2.1 Tension tests**

For bonded anchors only one steel type needs to be tested. The steel type with the highest strength shall be selected. The measured displacements shall be applied to anchors of all steel types and grades.

#### **2.2.4.2.2 Shear tests**

See 2.2.1.1.2.

### **2.2.4.3 Embedment depth**

#### **2.2.4.3.1 Tension tests:**

- a) Anchors under category C1 (test series C1.1):  
If multiple embedment depths are specified only the minimum and maximum embedment depths need to be tested.
- b) Anchors under category C2:  
If multiple embedment depths are specified, test series C2.1, C2.3 and C2.5 may only be performed with an embedment depth of  $h_{ef} = 7d$  as confined test in accordance with ETAG 001 Part 5, 5.0 to

ensure bond failure. In this case the reduction factors  $N_{,seis,C2}$  and  $S_{cv,N,C2}$  according to Equation (3.48) and Equation (3.49), respectively, at this embedment depth shall be applied to all embedment depths and the displacements measured at this embedment depth shall be applied to all embedment depths. If for  $h_{ef} = 7d$  steel failure occurs, the test shall be performed with a steel element having the same geometry but a higher steel strength than specified. In case steel failure does also occur in this situation the embedment depth shall be reduced such that bond failure is observed.

In addition test series C2.1 and C2.3 shall be performed with the largest embedment depth and the highest steel strength for use in seismic applications to capture the steel behaviour under pulsating tension load. The resulting reduction factors  $N_{,seis,C2}$  and  $S_{cv,N,C2}$  according to Equation (3.48) and Equation (3.49), respectively, for this steel strength shall be applied to all lower steel strengths. When calculating  $N_{,seis,C2}$  and  $S_{cv,N,C2}$  it shall be assumed that the reduction factors associated with the test series C2.5, which is not required in this case, are set equal to 1,0, i.e.  $\Gamma_{C2.5} = 1,0$  and  $S_{cv,C2.5} = 1,0$ . If steel failure is not obtained and lower steel grades are applied for use in seismic applications select a steel element with the next lower steel grade until steel failure is obtained. If steel failure is not obtained with the steel grades applied for use in seismic applications the reduction factors  $N_{,seis,C2}$  and  $S_{cv,N,C2}$  are both set equal to 1,0.

#### **2.2.4.3.2 Shear tests:**

See 2.2.1.3.2.

#### **2.2.4.4 Drilling method**

See 2.2.1.4.

### **2.2.5 Bonded expansion anchors**

#### **2.2.5.1 Steel type, steel grade and production method**

##### **2.2.5.1.1 Tension tests**

If all of the following conditions are fulfilled, and the eventual reduction factor is accepted for all anchor types, only anchors of one steel type, the highest steel grade and one production method need to be tested. Otherwise anchors of all steel types, steel grades and production methods shall be tested. Meaning, if all conditions are fulfilled for all steel types and steel grades but not for different production methods, then anchors of different production methods shall be tested.

- a) The geometry of the anchor is identical.
- b) The pre-stressing forces at torque  $T = 0,5 T_{inst}$  as well as at  $T = 1,0 T_{inst}$  are statistically equivalent for the different steel types, steel grades and production methods. The installation torque  $T_{inst}$  may be different for different steel types and grades.
- c) The slip force as well as the bond force, as defined in EOTA TR 018 [2], are statistically equivalent for the different steel types, steel grades and production methods. This condition shall be considered to be fulfilled if the anchors are made out of the same material, any coatings are the same, and the surface roughness of the anchor in the load transfer zone is statistically equivalent. For anchors made out of different materials (e.g. galvanized and corrosion resistant steel) this condition shall be considered to be fulfilled if the coating is identical, and the slip force depends mainly on the coating, and the surface roughness of the anchor in the load transfer zone is statistically equivalent.

The measured displacements shall be applied to the anchors made from other steel types, steel grades or by other production methods.

##### **2.2.5.1.2 Shear tests**

See 2.2.1.1.2.

#### **2.2.5.2 Head configuration**

See 2.2.1.2.

#### **2.2.5.3 Embedment depth**

See 2.2.1.3.

#### **2.2.5.4 Drilling method**

See 2.2.1.4.

## 2.3 Tests for category C1

### 2.3.1 Tests program

The additional tests for category C1 are shown in Table 2.1.

**Table 2.1 Additional tests for qualification of anchors under category C1**

	Purpose of test	Concrete	Crack width $U_w$ <sup>1)</sup> [mm]	Minimum number of tests <sup>2)</sup>	Test procedure see Section	Assessment criteria see Section
C1.1	Functioning under pulsating tension load	C20/25	0,5	5	2.3.2	3.1.1
C1.2	Functioning under alternating shear load	C20/25	0,5	5	2.3.3	3.1.2

<sup>1)</sup> Crack width added to the hairline crack width after anchor installation but before loading of anchor.  
<sup>2)</sup> Test all anchor diameters to be qualified for use in seismic applications. For anchors with different steel types, steel grades, production methods, head configurations (mechanical anchors), types of inserts (bonded anchors), multiple embedment depths and drilling methods see 2.2.

All tests shall be performed with anchors with a steel strength not smaller than the nominal value  $f_{uk}$ .

### 2.3.2 Tests under pulsating tension load

Purpose:

These tests are intended to evaluate the performance of anchors under simulated seismic tension loading, including the effects of cracks, and without edge effects.

General test conditions:

The test shall be performed with an unconfined test setup according to ETAG 001 Annex A, 5 with the following modifications for bonded anchors.

In general, bonded anchors shall be tested with a confined test setup in accordance with ETAG 001 Part 5, 5.0. If multiple embedment depths are specified, an embedment depth of  $h_{ef} = 7d$  is recommended for tests with the minimum embedment depth. Alternatively, tests with an unconfined test set-up may be performed. In this case the minimum embedment depth shall be selected such that pullout failure is ensured.

*In order to select the proper embedment depth for pullout failure for bonded anchors it shall be demonstrated that Equation (2.1) is fulfilled for the embedment depth  $h_{ef}$  used. If Equation (2.1) is not fulfilled with the chosen embedment depth, the embedment depth shall be increased until Equation (2.1) is fulfilled, where steel failure is avoided. If Equation (2.1) cannot be fulfilled in unconfined tests, confined tests shall be conducted (see above).*

$$7 \cdot h_{ef,test}^{1,5} \cdot \sqrt{f_{c,C1.1}} \leq N_{Ru,m} \cdot \left( \frac{f_{c,C1.1}}{f_{c,3}} \right)^n \leq 10 \cdot h_{ef,test}^{1,5} \cdot \sqrt{f_{c,C1.1}} \quad (2.1)$$

where

$N_{Ru,m}$  = mean tension capacity from admissible service condition tension tests in cracked concrete C20/25 performed with an unconfined test set-up according to ETAG 001 Part 5, Table 5.5, line 3 [N];

$h_{ef,test}$  = effective embedment depth [mm];

$f_{c,C1.1}$  = mean compressive strength of concrete measured with cubes used for the test series C1.1 at the time of testing [N/mm<sup>2</sup>];

$f_{c,3}$  = mean compressive strength of concrete measured with cubes used for the test series according to ETAG 001 Part 5, Table 5.5, line 3 at the time of testing [N/mm<sup>2</sup>];

$n$  = normalization exponent; see ETAG 001 Part 1 and Part 5, 6.0 (b).

In addition tests with the maximum embedment depth are required.

For all types of anchors the pulsating tension load tests shall be executed as described in the following:

Open the crack by  $U_w = 0,5$  mm. Subject the anchors to sinusoidal tension loads with the levels and cycle counts specified in Table 2.2 and Figure 2.6, where  $N_{eq}$  is given in Equation (2.2) in case of concrete or bond failure and in Equation (2.3) in case of steel failure,  $N_i$  is given in Equation (2.4), and  $N_m$  is given in Equation (2.5). The cycling frequency shall be between 0,1 and 2 Hz. The bottom of the tension load pulses may be taken to be slightly greater than zero to avoid servo control problems but shall not exceed  $N_{min}$ , with  $N_{min}$  being the maximum of 3% of  $N_{eq}$  and 200 N.

$$N_{eq} = 0,5 \cdot N_{Ru,m} \cdot \left( \frac{f_{c,C1.1}}{f_{c,3}} \right)^n \quad [\text{N}] \quad (\text{concrete or bond failure}) \quad (2.2)$$

where

$N_{Ru,m}$  = all anchors except bonded anchors:

Mean tension capacity from admissible service condition tension tests according to ETAG 001 Part 1, Table 5.4, line 3 for the considered embedment depth [N];

bonded anchors with unconfined test setup in test series C1.1:

Mean tension capacity from admissible service condition tension tests according to ETAG 001 Part 5, Table 5.5, line 3 for the considered embedment depth [N];

bonded anchors with confined test setup in test series C1.1:

Mean tension capacity from admissible service condition tension tests according to ETAG 001 Part 5, Table 5.6, line 3 for the considered embedment depth [N];

$f_{c,C1.1}$  = mean compressive strength of concrete used for the test series C1.1 at the time of testing [N/mm<sup>2</sup>];

$f_{c,3}$  = mean compressive strength of concrete used for the tests according to ETAG 001 Part 1, Table 5.4, line 3 and ETAG 001 Part 5, Table 5.5 or Table 5.6, line 3 (as applicable) at the time of testing [N/mm<sup>2</sup>];

$n$  = normalization exponent; see ETAG 001 Part 1 and Part 5, 6.0 (b).

$$N_{eq} = 0,5 \cdot N_{Ru,m} \cdot \left( \frac{f_{u,C1.1}}{f_{u,3}} \right) \quad [\text{N}] \quad (\text{steel failure}) \quad (2.3)$$

where

$N_{Ru,m}$  = Mean tension steel capacity from admissible service condition tension tests according to ETAG 001 Part 1, Table 5.4, line 3, ETAG 001 Part 5, Table 5.5 or Table 5.6, line 3 (as applicable) [N];

$f_{u,C1.1}$  = ultimate mean steel strength of anchors used for test series C1.1 [N/mm<sup>2</sup>];

$f_{u,3}$  = ultimate mean steel strength of anchors used for tests according to ETAG 001 Part 1, Table 5.4, line 3 and ETAG 001 Part 5, Table 5.5 or Table 5.6, line 3 (as applicable) [N/mm<sup>2</sup>];

Adjustment for different steel strengths in Equation (2.3) is not required if the anchors used in test series C1.1 and tests according to ETAG 001 Part 1, Table 5.4, line 3 and ETAG 001 Part 5, Table 5.5 or Table 5.6, line 3 (as applicable) are taken from the same production lot.

If mixed failure modes occur in the test series according to ETAG 001 Part 1, Table 5.4, line 3 or ETAG 001 Part 5, Table 5.5 or 5.6, line 3 (as applicable) the load  $N_{eq}$  shall be determined assuming that the failure mode, which was observed in the majority of tests in the test series, occurred in all tests.

$$N_i = 0,75 \cdot N_{eq} \quad [\text{N}] \quad (2.4)$$

$$N_m = 0,5 \cdot N_{eq} \quad [\text{N}] \quad (2.5)$$

**Table 2.2 Required loading history for test series C1.1**

Load level	$N_{eq}$	$N_i$	$N_m$
Number of cycles ( $n_{cyc}$ )	10	30	100

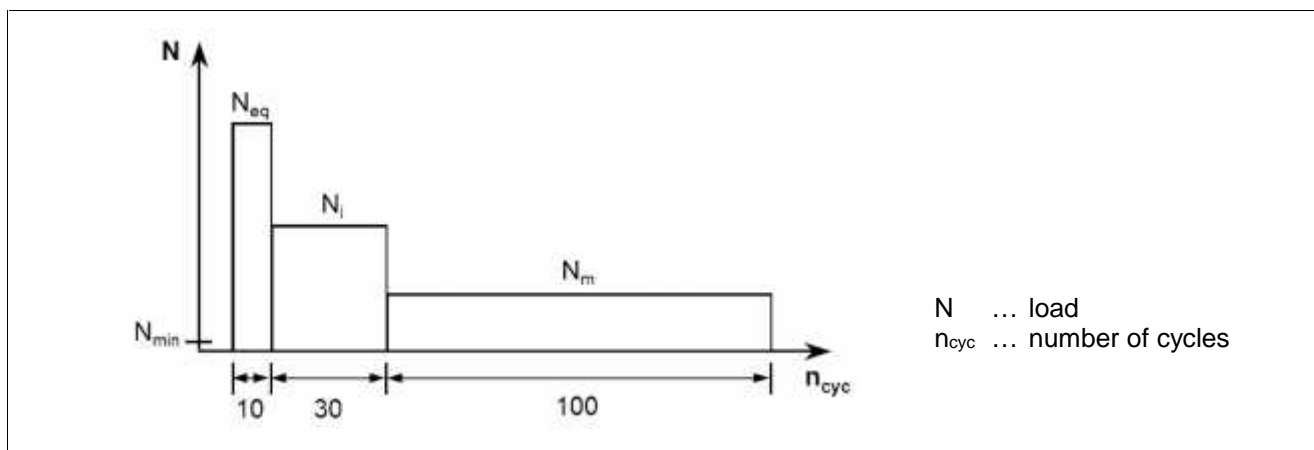

**Figure 2.6 Required loading history for test series C1.1**

Record the crack width, anchor displacement and applied tension load. Following completion of the simulated seismic-tension cycles, open the crack by  $w = 0,5$  mm, but not less than the crack opening width as measured at the end of the cyclic test and load the anchor in tension to failure. Record the maximum tension load (residual tension capacity), the corresponding displacement, the crack width, and plot the load-displacement response.

If the anchor fails to fulfil the requirements given in the corresponding assessment (see 3.1.1) it shall be permitted to conduct the tests with a reduced load level.

### 2.3.3 Tests under alternating shear load cycling

Purpose:

These tests are intended to evaluate the performance of anchors under simulated seismic shear loading, including the effects of concrete cracking.

General test conditions:

The test shall be performed according to ETAG 001 Annex A, 5 with the following modifications.

Open the crack by  $U_w = 0,5$  mm. Subject the anchors to sinusoidal shear loads in the direction of the crack with the levels and cycle counts specified in Table 2.3 and Figure 2.7, where  $V_{eq}$  is given in Equation (2.6), Equation (2.7), or Equation (2.8) as applicable,  $V_i$  is given in Equation (2.9) and  $V_m$  is given in Equation (2.10). The cycling frequency shall be between 0,1 and 2 Hz.

$$V_{eq} = 0,5 \cdot V_{Ru,m} \cdot \left( \frac{f_{u,C1.2}}{f_{u,5}} \right) \quad [\text{N}] \quad (\text{anchors without sleeve in shear plane}) \quad (2.6)$$

where

$V_{Ru,m}$  = mean shear capacity from admissible service condition shear tests in non-cracked concrete C20/25 (see ETAG 001 Part 1, Table 5.4, line 5) [N];

$f_{u,C1.2}$  = mean ultimate tensile strength of steel anchor elements used in test series C1.2 [N/mm<sup>2</sup>];

$f_{u,5}$  = mean ultimate tensile strength of steel anchor elements used in test series according to ETAG 001 Part 1, Table 5.4, line 5 [N/mm<sup>2</sup>].

For anchors with a sleeve in the shear plane  $V_{eq}$  shall be calculated according to Equation (2.7).

$$V_{eq} = 0,5 \cdot V_{Ru,m} \cdot \left( \frac{f_{u,bolt,C1.2}}{f_{u,bolt,5}} \cdot \frac{A_{s,bolt}}{A_{s,anchor}} + \frac{f_{u,sleeve,C1.2}}{f_{u,sleeve,5}} \cdot \frac{A_{s,sleeve}}{A_{s,anchor}} \right) [\text{N}] \quad (2.7)$$

where

$V_{Ru,m}$  = as defined in Equation (2.6) [N];

$f_{u,bolt,C1.2}$  = mean ultimate tensile strength of bolt used in test series C1.2 [N/mm<sup>2</sup>];

- $f_{u,sleeve,C1.2}$  = mean ultimate tensile strength of sleeve used in test series C1.2 [N/mm<sup>2</sup>];
- $f_{u,bolt,5}$  = mean ultimate tensile strength of bolt used in test series according to ETAG 001 Part 1, Table 5.4, line 5 [N/mm<sup>2</sup>];
- $f_{u,sleeve,5}$  = mean ultimate tensile strength of sleeve used in test series according to ETAG 001 Part 1, Table 5.4, line 5 [N/mm<sup>2</sup>];
- $A_{s,bolt}$  = effective cross section of bolt [mm<sup>2</sup>];
- $A_{s,sleeve}$  = effective cross section of sleeve [mm<sup>2</sup>];
- $A_{s,anchor}$  =  $A_{s,bolt} + A_{s,sleeve}$  [mm<sup>2</sup>];

Adjustment for different steel strengths in Equations (2.6) and (2.7) is not required if the anchors tested in C1.2 and in tests according to ETAG 001 Part 1, Table 5.4, line 5 are taken from the same production lot.

If service condition shear tests have not been performed according to ETAG 001 Part 1, Table 5.4, line 5 (which is allowed only for anchors with no significantly reduced section along the length of the bolt and no sleeve in the shear plane, that is taken into account in the shear resistance),  $V_{eq}$  shall be permitted to be calculated in accordance with Equation (2.8).

$$V_{eq} = 0,35 \cdot A_s \cdot f_{uk} \quad [\text{N}] \quad (2.8)$$

where

- $A_s$  = effective stressed cross section area of steel element in the shear plane [mm<sup>2</sup>];
- $f_{uk}$  = characteristic steel ultimate tensile strength (nominal value) of the finished product [N/mm<sup>2</sup>];

$$V_i = 0,75 \cdot V_{eq} \quad [\text{N}] \quad (2.9)$$

$$V_m = 0,5 \cdot V_{eq} \quad [\text{N}] \quad (2.10)$$

**Table 2.3 Required loading history for test series C1.2**

Load level	$\pm V_{eq}$	$\pm V_i$	$\pm V_m$
Number of cycles ( $n_{cyc}$ )	10	30	100

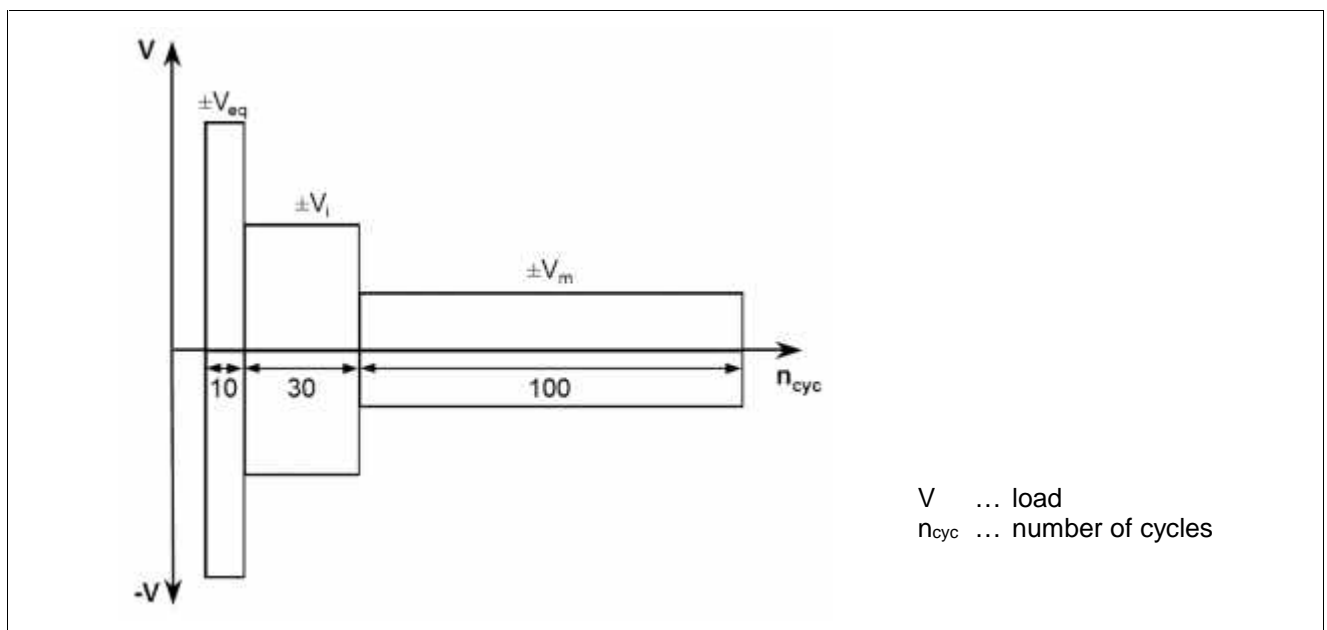

**Figure 2.7 Required load history for test series C1.2**

To reduce the potential for uncontrolled slip during load reversal, the alternating shear loading is permitted to be approximated by two half-sinusoidal load cycles at the required frequency connected by a reduced speed, ramped load as shown in Figure 2.8.

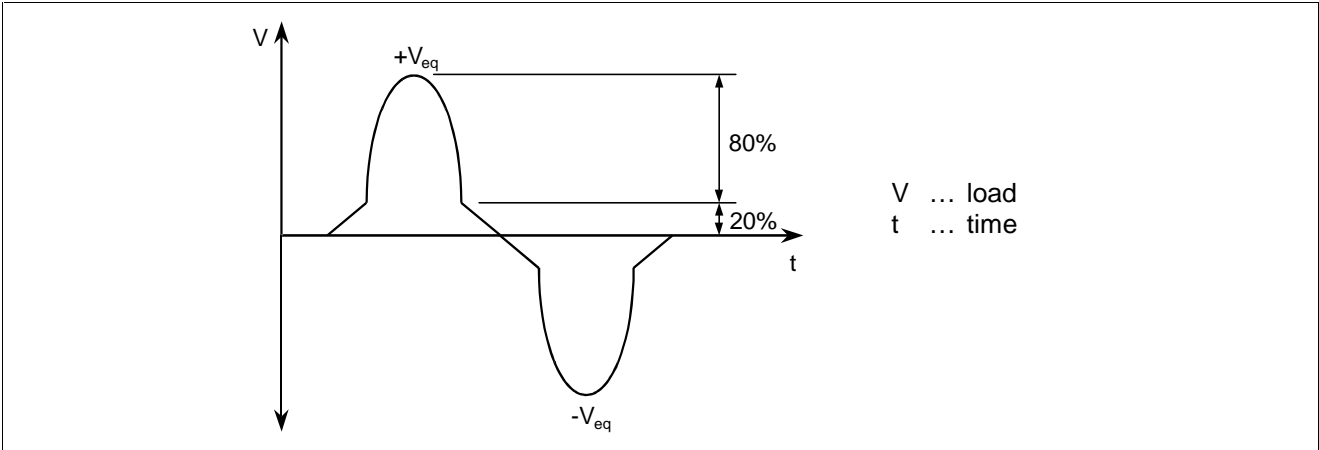

**Figure 2.8 Permitted approximation of seismic shear cycle C1.2**

Record the crack width, anchor displacement and applied shear load. Plot the load-displacement history in the form of hysteresis loops.

Following completion of the simulated seismic shear cycles, open the crack by  $w = 0,5 \text{ mm}$ , but not less than the crack opening width as measured at the end of the cyclic shear test and load the anchor in shear to failure. Record the maximum shear load (residual shear capacity), the corresponding displacement, the crack width, and plot the load-displacement response.

If the anchor fails to fulfil the requirements given in the corresponding assessment (see 3.1.2) it shall be permitted to conduct the tests with a reduced load level.



## 2.4 Tests for category C2

### 2.4.1 Test program

The required additional tests for anchors of category C2 are given in Table 2.4.

**Table 2.4 Additional tests for qualification of anchors under category C2**

Test no.	Purpose of test	Concrete	Crack width $w$ <sup>1)</sup> [mm]	Minimum number of tests <sup>2)</sup>	Test procedure see Section	Assessment criteria see Section
C2.1a	Reference tension tests in low strength concrete	C20/25	0,8	5	2.4.2	3.2.1, 3.2.2
C2.1b	Tension tests in high strength concrete	C50/60	0,8	5	2.4.2	3.2.1, 3.2.2
C2.2 <sup>3)</sup>	Reference shear tests	C20/25	0,8	5	2.4.2	3.2.1, 3.2.3
C2.3	Functioning under pulsating tension load	C20/25	0,5 ( $0,5 \cdot N/N_{max}$ ) <sup>4)</sup> 0,8 ( $> 0,5 \cdot N/N_{max}$ )	5	2.4.3	3.2.1, 3.2.4
C2.4	Functioning under alternating shear load	C20/25	0,8	5	2.4.4	3.2.1, 3.2.5
C2.5	Functioning with tension load under varying crack width	C20/25	$w_1 = 0,0$ <sup>5)</sup> $w_2 = 0,8$	5	2.4.5	3.2.1, 3.2.6

<sup>1)</sup> Crack width  $w$  added to the width of hairline crack after anchor installation but before loading of anchor.

<sup>2)</sup> Test all anchor diameters for which the anchor is to be qualified for use in seismic applications. For anchors with different steel types, steel grades, production methods, head configurations (mechanical anchors), types of inserts (bonded anchors), multiple embedment depths and drilling methods see 2.2.

<sup>3)</sup> See 2.4.2

<sup>4)</sup> The tests may also be conducted in  $w = 0,8$  mm at all load levels ( $N/N_{max}$ ).

<sup>5)</sup>  $w_1 = 0,0$  mm is defined in 2.4.5.

Test series C2.1, C2.3 and C2.5 shall be performed with the same embedment depths and test set-up (confinement conditions). This requirement is also valid for test series C2.2 and C2.4.

*Test series C2.1, C2.3 and C2.5:*

Bonded anchors shall be tested with a confined test setup in accordance with ETAG 001 Part 5, 5.0 with an embedment depth and steel strength as defined in 2.2.4.3. All other anchors shall be tested with an unconfined test setup.

All tests shall be performed with anchors with a steel strength not smaller than the nominal value  $f_{uk}$ .

### 2.4.2 Tension tests C2.1 and shear tests C2.2

The tension test series C2.1 and shear test series C2.2 shall be performed in accordance with ETAG 001 Annex A, 5.2.1 with a crack width as specified in Table 2.4.

The test series C2.2 may be omitted if the results according to ETAG 001 Part 1, Table 5.4, line 5 ( $w = 0,0$  mm) are accepted as  $V_{u,m,C2.2}$ . If tests according to ETAG 001 Part 1, Table 5.4, line 5 have not been performed (which is allowed only for anchors with no significantly reduced section along the length of the bolt and no sleeve in the shear plane, that is taken into account in the shear resistance), the reference mean failure load shall be calculated according to Equation (2.11).

$$V_{u,m,C2.2} = 0,6 \cdot A_s \cdot f_{u,C2.2} \text{ [N]} \quad (2.11)$$

where

$f_{u,C2.2}$  = measured mean ultimate tension strength of the anchors used in test series C2.2 [N/mm<sup>2</sup>].

If in the test series C2.2 failure is caused by pullout or pull-through of the anchor the test may be repeated with a larger embedment depth avoiding these failure modes (compare 3.2.3).

### 2.4.3 Tests under pulsating tension load

The tests shall be performed according to ETAG 001, Annex A and 2.1.1 with the following modifications:

Open the crack by  $w = 0,5$  mm (see exception in Footnote 4 of Table 2.4). Subject the anchor to the sinusoidal tension loads specified in Table 2.5 and Figure 2.9 with a cycling frequency no greater than 0,5 Hz, where  $N_{max}$  is given by Equation (2.12) to Equation (2.14). Triangular loading cycles may be used in place of sinusoidal cycles. The bottom of the tension load pulses may be taken to be slightly greater than zero to avoid servo control problems but shall not exceed  $N_{min}$ , with  $N_{min}$  being the maximum of 2% of  $N_{max}$  and 200 N. Crack width shall be controlled during load cycling. The crack shall be opened to  $w = 0,8$  mm after the load cycles at  $0,5 N/N_{max}$  have been completed.

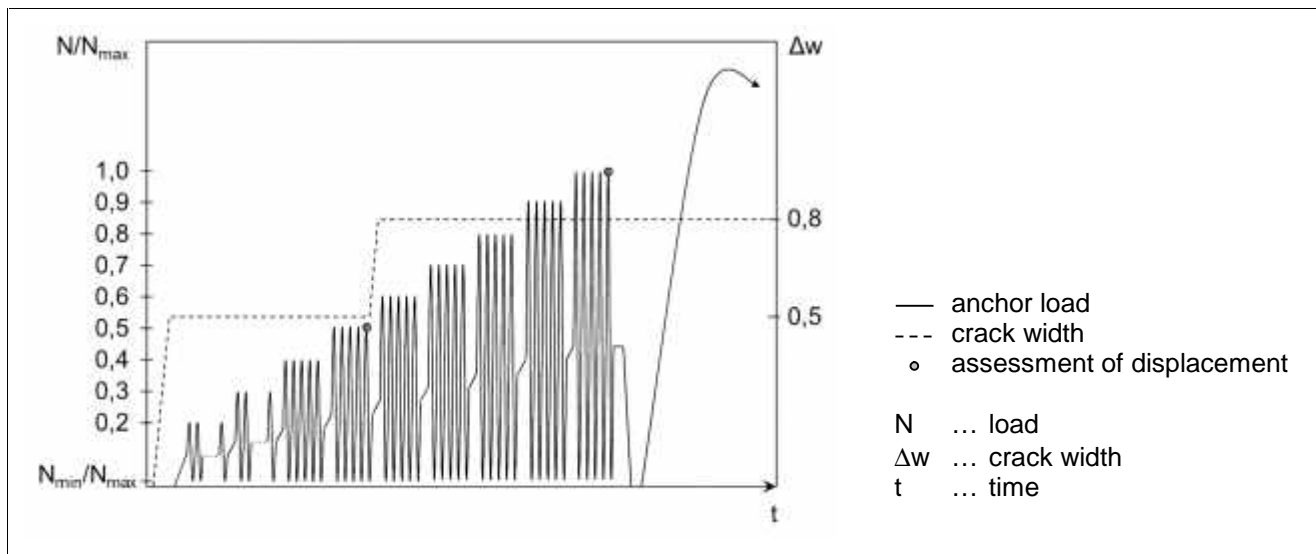

Figure 2.9 Schematic test procedure C2.3

Table 2.5 Required load amplitudes for test series C2.3

$N/N_{max}$	Number of cycles	Crack width $w$ [mm]
0,2	25	0,5
0,3	15	0,5
0,4	5	0,5
0,5	5	0,5
0,6	5	0,8
0,7	5	0,8
0,8	5	0,8
0,9	5	0,8
1	5	0,8
SUM	75	

Depending on the failure mode observed in test C2.1a,  $N_{max}$  is determined as follows:

Steel failure

$$N_{max} = 0,75 \cdot N_{u,m,C2.1a} \cdot \left( \frac{f_{u,C2.3}}{f_{u,C2.1a}} \right) \text{ [N]} \quad (2.12)$$

Bond failure of bonded anchors

$$N_{\max} = 0,75 \cdot N_{u,m,C2.1a} \cdot \left( \frac{f_{c,C2.3}}{f_{c,C2.1a}} \right)^n \quad [\text{N}] \quad (2.13)$$

All other failure modes

$$N_{\max} = 0,75 \cdot N_{u,m,C2.1a} \cdot \left( \frac{f_{c,C2.3}}{f_{c,C2.1a}} \right)^{0,5} \quad [\text{N}] \quad (2.14)$$

where

$N_{u,m,C2.1a}$  = mean tension capacity from the reference test series C2.1a [N];

$f_{u,C2.3}$  = ultimate mean steel strength of anchors used in the test series C2.3 [N/mm<sup>2</sup>];

$f_{u,C2.1a}$  = ultimate mean steel strength of anchors used in the test series C2.1a [N/mm<sup>2</sup>];

$f_{c,C2.3}$  = mean compressive strength of concrete at the time of testing of the test series C2.3 [N/mm<sup>2</sup>];

$f_{c,C2.1a}$  = mean compressive strength of concrete at the time of testing of the test series C2.1a [N/mm<sup>2</sup>];

$n$  = normalization factor to account for concrete strength; ETAG 001 Part 5, 6.0(b).

If mixed failure modes occur in test series C2.1a, the largest value of Equations (2.12) and (2.14) shall be applied.

Adjustment for different steel strengths in Equation (2.12) is not required if the anchors tested in C2.1a and C2.3 are taken from the same production lot.

Record the crack width, anchor displacement and applied tension load continuously during the simulated seismic tension cycles. Report the displacements at minimum and maximum load and the crack width as a function of the number of load cycles.

Following completion of the simulated seismic tension cycles unload the anchor. During the unloading of the anchor the crack width may get smaller. For the residual capacity test open the crack to  $w = 0,8$  mm, but not less than the crack opening width as measured at the end of the cyclic test, and load the anchor in tension to failure. Record the maximum tension load (residual tension capacity), the corresponding displacement, the crack width, and plot the load-displacement response.

If the anchor fails to fulfil the requirements given in the corresponding assessment (see 3.2.4) it shall be permitted to conduct the tests with a reduced load level.

If the anchor meets the requirements given in the corresponding assessment but a smaller displacement at the first assessment point (i.e. at the end of load cycling at level  $0,5 \cdot N/N_{\max}$ ; see 3.2.4 and Figure 2.9) is intended it shall be permitted to conduct the test with a reduced load level.

#### 2.4.4 Tests under alternating shear load

The tests shall be performed according to ETAG 001 Annex A and 2.1.1 with the following modifications:

Open the crack by  $w = 0,8$  mm. Subject the anchor to the sinusoidal shear loads specified in Table 2.6 and Figure 2.10 with a cycling frequency no greater than 0,5 Hz, where  $V_{\max}$  is given by Equation (2.15), Equation (2.16) or Equation (2.17) as applicable.

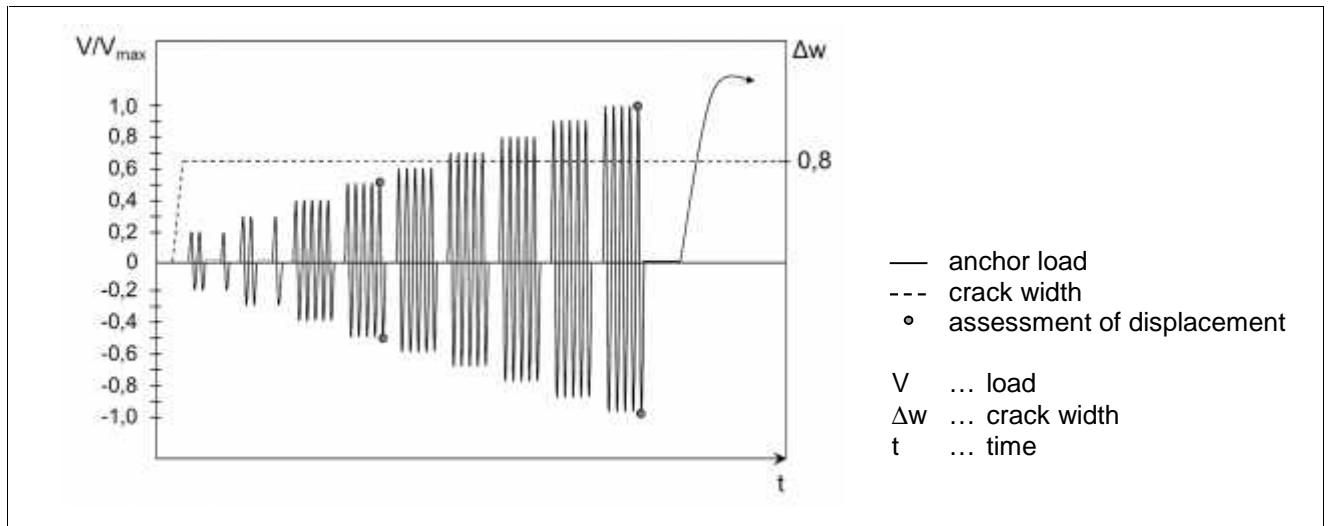

Figure 2.10 Schematic test procedure C2.4

Table 2.6 Required load amplitudes for test series C2.4

$\pm V/V_{max}$	Number of cycles	Crack width $w$ [mm]
0,2	25	0,8
0,3	15	0,8
0,4	5	0,8
0,5	5	0,8
0,6	5	0,8
0,7	5	0,8
0,8	5	0,8
0,9	5	0,8
1	5	0,8
SUM	75	

$$V_{max} = 0,85 \cdot V_{u,m,C2.2} \left( \frac{f_{u,C2.4}}{f_{u,C2.2}} \right) \text{ [N]} \quad (\text{anchors without sleeve in shear plane}) \quad (2.15)$$

where

$V_{u,m,C2.2}$  = mean shear capacity from the reference test series C2.2 [N];

$f_{u,C2.4}$  = ultimate mean steel strength of anchors used in the test series C2.4 [N/mm<sup>2</sup>];

$f_{u,C2.2}$  = ultimate mean steel strength of anchors used in the test series C2.2 [N/mm<sup>2</sup>].

For anchors with a sleeve in the shear plane  $V_{eq}$  shall be calculated according to Equation (2.16).

$$V_{max} = 0,85 \cdot V_{u,m,C2.2} \cdot \left( \frac{f_{u,bolt,C2.4}}{f_{u,bolt,C2.2}} \cdot \frac{A_{s,bolt}}{A_{s,anchor}} + \frac{f_{u,sleeve,C2.4}}{f_{u,sleeve,C2.2}} \cdot \frac{A_{s,sleeve}}{A_{s,anchor}} \right) \text{ [N]} \quad (2.16)$$

where

$V_{u,m,C2.2}$  = as defined in Equation (2.15) [N];

$f_{u,bolt,C2.4}$  = mean ultimate tensile strength of bolt used in test series C2.4 [N/mm<sup>2</sup>];

$f_{u,sleeve,C2.4}$  = mean ultimate tensile strength of sleeve used in test series C2.4 [N/mm<sup>2</sup>];

$f_{u,bolt,C2.2}$  = mean ultimate tensile strength of bolt used in test series C2.2 [N/mm<sup>2</sup>];

$f_{u,sleeve,C2.2}$  = mean ultimate tensile strength of sleeve used in test series C2.2 [N/mm<sup>2</sup>];

$A_{s,bolt}$  = effective cross section of bolt [mm<sup>2</sup>];

$A_{s,sleeve}$  = effective cross section of sleeve [mm<sup>2</sup>];

$$A_{s,anchor} = A_{s,bolt} + A_{s,sleeve} \text{ [mm}^2\text{]}.$$

Adjustment for different steel strengths in Equations (2.15) and (2.16) is not required if the anchors tested in C2.2 and C2.4 are taken from the same production lot.

If reference shear tests C2.2 have not been performed, which is allowed only for anchors with no significantly reduced section along the length of the bolt and no sleeve in the shear plane, that is taken into account in the shear resistance,  $V_{max}$  shall be permitted to be calculated in accordance with Equation (2.17).

$$V_{max} = 0,5 \cdot A_s \cdot f_{u,C2.4} \text{ [N]} \quad (2.17)$$

where

$A_s$  = effective cross section area of anchor in shear plane [mm<sup>2</sup>];

$f_{u,C2.4}$  = ultimate mean steel strength of anchors used in the test series C2.4 [N/mm<sup>2</sup>].

The load shall be applied parallel to the direction of the crack. To reduce the potential for uncontrolled slip during load reversal, an approximation by two half-sinusoidal load cycles at the required frequency connected by a reduced speed, ramped load (see Figure 2.11b) or simply triangular loading cycles (see Figure 2.11c) may be used in place of sinusoidal cycles (see Figure 2.11a). The crack width shall be controlled during load cycling.

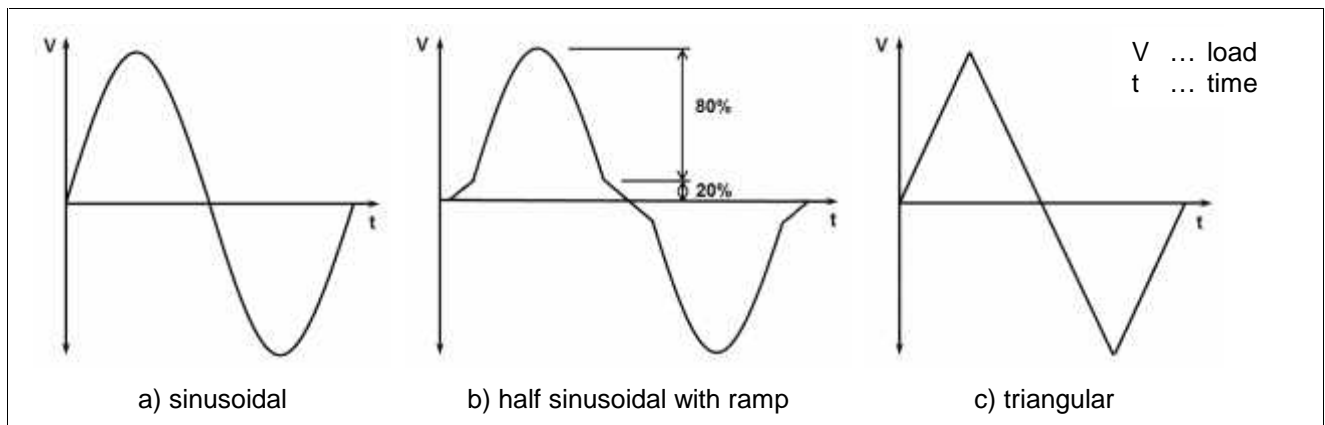

**Figure 2.11 Permitted seismic shear cycle C2.4**

Record the crack width, anchor displacement and applied shear load continuously during the simulated seismic shear cycles. Report the displacements at minimum and maximum load and the crack width as a function of the number of load cycles.

Following completion of the simulated seismic shear cycles unload the anchor. During the unloading of the anchor the crack width may get smaller. For the residual capacity test open the crack to  $w = 0,8 \text{ mm}$ , but not less than the crack opening width as measured at the end of the cyclic test, and load the anchor in shear to failure. Record the maximum shear load (residual shear capacity), the corresponding displacement, the crack width, and plot the load-displacement response.

If the anchor fails to fulfil the requirements given in the corresponding assessment (see 3.2.5) it shall be permitted to conduct the tests with a reduced load level.

If the anchor meets the requirements given in the corresponding assessment but a smaller displacement at the first assessment point (i.e. at the end of load cycling at level  $0,5 \cdot V/V_{max}$ ; see 3.2.5 and Figure 2.10) is intended it shall be permitted to conduct the test with a reduced load level.

If in the test series C2.4 failure is caused by pullout or pull-through the test may be repeated with a larger embedment depth avoiding these failure modes (compare 3.2.5).

#### 2.4.5 Tests with tension load and varying crack width

The tests shall be performed according to ETAG 001 Annex A and 2.1.1 with the following modifications:

Tests shall be carried out on one anchor at a time with no other anchors installed in the same crack.

Prior to installing anchors in the test member, loading cycles as required to initiate cracking and to stabilise the relationship between crack width and applied load may be applied to the test member. This loading shall not exceed the elastic limit of the test member.

In order to create similar starting conditions when using a test member with one crack plane and a test member with multiple crack planes the initiated hairline crack may be closed by applying a centric compression force  $C_{ini}$  according to Equation (2.18) on the concrete test member.

$$C_{ini} = 0,01 \cdot f_{c,C2.5} \cdot A_g \quad [\text{N}] \quad (2.18)$$

where

- $A_g$  = cross section area of the test member [mm<sup>2</sup>];
- =  $b \cdot h$ , with  $b$  and  $h$  being the width and thickness of the test member, respectively;
- $f_{c,C2.5}$  = mean compressive strength of concrete measured on cubes at the time of testing of the test series C2.5 [N/mm<sup>2</sup>].

Install the anchor in the hairline crack according to 2.1.2. When  $C_{ini}$  is applied for testing bonded anchors and bonded expansion anchors the following procedure may be applied: remove the compression force  $C_{ini}$ , install the anchor according to 2.1.2 and after curing again apply  $C_{ini}$  on the concrete test member.

Place crack measurement displacement transducers according to 2.1.3 and zero the devices. Following application of load to the anchor sufficient to remove any slack in the loading mechanism, begin recording the anchor displacement and increase the tension load on the anchor to  $N_{w1}$  as given by Equation (2.20) to Equation (2.22). With the anchor load  $N_{w1}$  held constant, begin the crack cycling program specified in Table 2.7 and Figure 2.12 with a cycling frequency no greater than 0,5 Hz. The first crack movement is in the direction of crack closure by applying a compression load on the test member.

*Note: The initial crack width  $w_{ini}$  after applying  $N_{w1}$  may exceed  $Uw = 0,1$  mm. In this case the first crack movement in the direction of crack closure will close the crack and the crack cycling program is performed starting with  $Uw = 0,1$  mm (see Figure 2.12).*

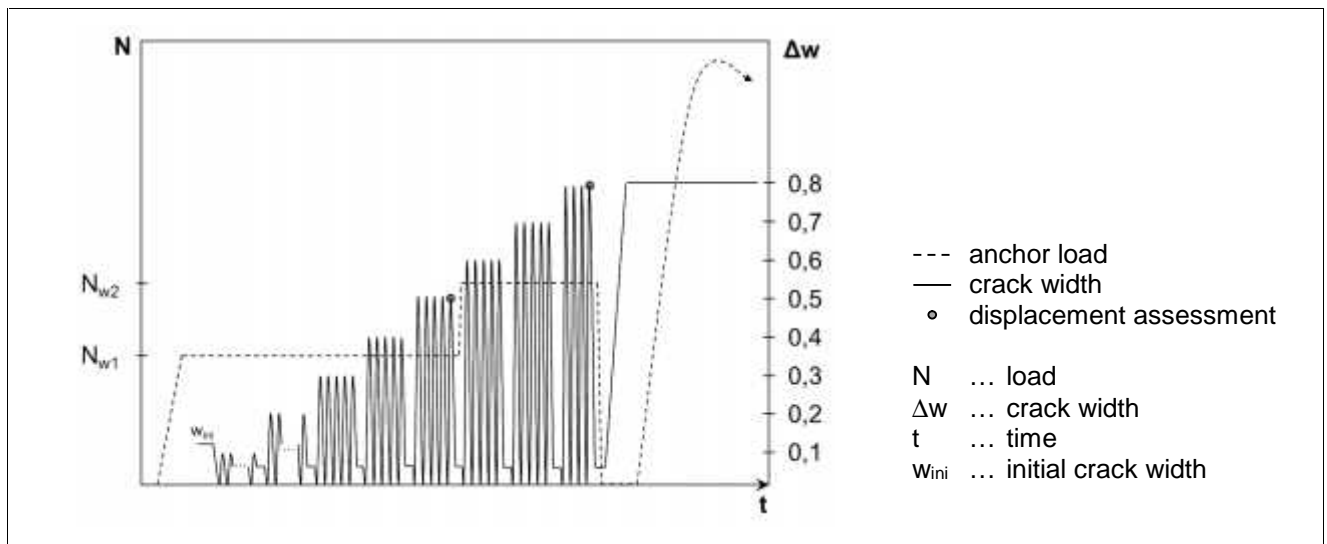

**Figure 2.12 Schematic test procedure C2.5**

**Table 2.7 Required crack widths for test series C2.5**

Crack width $w$ [mm]	Number of cycles	Anchor load
0,1	20	$N_{w1}$
0,2	10	$N_{w1}$
0,3	5	$N_{w1}$
0,4	5	$N_{w1}$
0,5	5	$N_{w1}$
0,6	5	$N_{w2}$
0,7	5	$N_{w2}$
0,8	4	$N_{w2}$
SUM	59	

In each cycle the crack shall be closed by applying a centric compression force  $C_{test}$  according to Equation (2.19)

$$C_{test} = 0,1 \cdot f_{c,C2.5} \cdot A_g \quad [\text{N}] \quad (2.19)$$

where

$A_g$  = cross section area of the test member [mm<sup>2</sup>];

=  $b \cdot h$ , with  $b$  and  $h$  being the width and thickness of the test member, respectively;

$f_{c,C2.5}$  = mean compressive strength of concrete measured on cubes at the time of testing of the test series C2.5 [N/mm<sup>2</sup>].

If the crack is not closed to  $w = 0,1$  mm when applying  $C_{test}$  according to Equation (2.19), then the compression force shall be increased until either  $w = 0,1$  mm is achieved or the compression force reaches the maximum value of  $C_{test,max} = 0,15 \cdot f_{c,C2.5} \cdot A_g$ . This procedure fulfils the requirement of  $U_{w1} = 0$  mm (see Table 2.4).

Depending on the failure mode observed in the test series C2.1a,  $N_{w1}$  is determined as follows:

Steel Failure

$$N_{w1} = 0,4 \cdot N_{u,m,C2.1a} \cdot \left( \frac{f_{u,C2.5}}{f_{u,C2.1a}} \right) \quad [\text{N}] \quad (2.20)$$

Bond Failure of bonded anchors

$$N_{w1} = 0,4 \cdot N_{u,m,C2.1a} \cdot \left( \frac{f_{c,C2.5}}{f_{c,C2.1a}} \right)^n \quad [\text{N}] \quad (2.21)$$

All other failure modes

$$N_{w1} = 0,4 \cdot N_{u,m,C2.1a} \cdot \left( \frac{f_{c,C2.5}}{f_{c,C2.1a}} \right)^{0,5} \quad [\text{N}] \quad (2.22)$$

where

$N_{u,m,C2.1a}$  = mean tension capacity from the test series C2.1a [N];

$f_{u,C2.5}$  = ultimate mean steel strength of anchors used in the test series C2.5 [N/mm<sup>2</sup>];

$f_{u,C2.1a}$  = ultimate mean steel strength of anchors used in the test series C2.1a [N/mm<sup>2</sup>];

$f_{c,C2.5}$  = mean compressive strength of concrete used at the time of testing in the test series C2.5 [N/mm<sup>2</sup>];

$f_{c,C2.1a}$  = mean compressive strength of concrete used at the time of testing in the test series C2.1a [N/mm<sup>2</sup>];

$n$  = normalization factor to account for concrete strength; ETAG 001 Part 5, 6.0(b).

If mixed failure modes occur in the test series C2.1a, the largest value of Equations (2.20) and (2.22) shall be applied.

After completion of the crack cycles at crack width  $w = 0,5$  mm, increase the tension load on the anchor to  $N_{w2}$  as given by Equation (2.23) to Equation (2.25) and then continue the crack cycling sequence to completion.

Depending on the failure mode observed in the test series C2.1a,  $N_{w2}$  is determined as follows:

Steel Failure

$$N_{w2} = 0,5 \cdot N_{u,m,C2.1a} \cdot \left( \frac{f_{u,C2.5}}{f_{u,C2.1a}} \right) \text{ [N]} \quad (2.23)$$

Bond Failure of bonded anchors

$$N_{w2} = 0,5 \cdot N_{u,m,C2.1a} \cdot \left( \frac{f_{c,C2.5}}{f_{c,C2.1a}} \right)^n \text{ [N]} \quad (2.24)$$

All other failure modes

$$N_{w2} = 0,5 \cdot N_{u,m,C2.1a} \cdot \left( \frac{f_{c,C2.5}}{f_{c,C2.1a}} \right)^{0,5} \text{ [N]} \quad (2.25)$$

with  $N_{u,m,C2.1a}$ ,  $f_{u,C2.5}$ ,  $f_{u,C2.1a}$ ,  $f_{c,C2.5}$ ,  $f_{c,C2.1a}$ , and  $n$  as defined in Equation (2.20) to Equation (2.22).

If mixed failure modes occur in the test series C2.1a, the largest value of Equations (2.23) and (2.25) shall be applied.

Adjustment for different steel strengths in Equation (2.20) and Equation (2.23) is not required if the anchors tested in C2.1 and C2.5 are taken from the same production lot.

Record the crack width, anchor displacement and applied tension load continuously during the simulated seismic crack cycles. Report the displacements at minimum and maximum crack width and the applied tension load as a function of the number of crack cycles.

Following completion of the simulated seismic crack cycles unload the anchor. During the unloading of the anchor the crack width may get smaller. For the residual capacity test open the crack to  $w = 0,8$  mm, but not less than the crack opening width as measured at the end of the cyclic test, and load the anchor in tension to failure. Record the maximum tension load (residual tension capacity), the corresponding displacement, the crack width, and plot the load-displacement response.

If the anchor fails to fulfil the requirements given in the corresponding assessment (see 3.2.6) it shall be permitted to conduct the tests with a reduced load level.

If the anchor meets the requirements given in the corresponding assessment but a smaller displacement at the first assessment point (i.e. at the end of crack width cycling at level  $w = 0,5$  mm; see 3.2.6 and Figure 2.12) is intended it shall be permitted to conduct the test with a reduced load level.

### 3 Assessment and judging the fitness for intended use

#### 3.1 Assessment for category C1

##### 3.1.1 Assessment of tests under pulsating tension load

All anchors in a test series shall complete the simulated seismic tension load history specified in Table 2.2 and Figure 2.6. Failure of an anchor to develop the required resistance in any cycle prior to completing the load history specified in Table 2.2 and Figure 2.6 shall be recorded as an unsuccessful test. The mean residual capacity of the anchors in the test series shall be equal to or greater than 160% of  $N_{eq}$  as given by Equation (2.2) or Equation (2.3), as applicable.



Successful completion of the cyclic loading history and fulfilment of the residual tension capacity requirement of this section shall be reported. In this case the seismic reduction factor for tension loading according to Equation (3.1) is  $\Gamma_{N,seis,C1} = 1,0$ .

If the anchor fails to fulfil one of the above requirements at  $N_{eq}$ , it shall be permitted to conduct the test with reduced cyclic loads  $N_{eq,reduced}$  until the requirements are met. The loading history specified in Table 2.2 and Figure 2.6 shall be applied, where  $N_{eq,reduced}$ ,  $N_i,reduced$  and  $N_m,reduced$  are substituted for  $N_{eq}$ ,  $N_i$  and  $N_m$ , respectively. All anchors in a test series shall complete the simulated seismic tension load history. Failure of an anchor to develop the required tension resistance in any cycle prior to completing the loading history given in Table 2.2 and Figure 2.6 shall be recorded as an unsuccessful test. The mean residual capacity of the anchors in the test series shall be at least 160% of the reduced load  $N_{eq,reduced}$ . Successful completion of the cyclic loading history with reduced load values and fulfilment of the residual tension capacity requirement of this section shall be recorded together with the type of failure mode causing the reduced load values and the reduction factor  $\Gamma_{N,seis,C1}$  as given by Equation (3.1).

$$\Gamma_{N,seis,C1} = \frac{N_{eq,reduced}}{N_{eq}} \quad (3.1)$$

This reduction factor is valid for anchors with the tested embedment depth and all smaller embedment depths.

If anchors with more than one embedment depth have been tested and different failures are observed in these tests then different reduction factors for steel and pullout (bond) failure may be obtained.

The reduction factor  $\Gamma_{N,seis,C1}$  shall be used to determine the characteristic resistances under seismic loading according to 3.3.1.

### 3.1.2 Assessment of tests under alternating shear load

All anchors in a test series shall complete the simulated seismic shear load history specified in Table 2.3 and Figure 2.7. Failure of an anchor to develop the required resistance in any cycle prior to completing the loading history specified in Table 2.3 and Figure 2.7 shall be recorded as an unsuccessful test. The mean residual capacity of the anchors in the test series shall be at least 160% of  $V_{eq}$  given by Equation (2.6), Equation (2.7) or Equation (2.8), as applicable.

Successful completion of the cyclic loading history and fulfilment of the residual shear capacity requirement of this section shall be reported. In this case the seismic reduction factor for shear loading according to Equation (3.2) is  $\Gamma_{V,seis,C1} = 1,0$ .

If the anchor fails to fulfil one of the above requirements at  $V_{eq}$ , it shall be permitted to conduct the test with reduced cyclic loads  $V_{eq,reduced}$  until the requirements are met. The loading history specified in Table 2.3 and Figure 2.7 shall be applied, where  $V_{eq,reduced}$ ,  $V_i,reduced$  and  $V_m,reduced$  are substituted for  $V_{eq}$ ,  $V_i$  and  $V_m$ , respectively. All anchors in a test series shall complete the simulated seismic shear load history. Failure of an anchor to develop the required shear resistance in any cycle prior to completing the loading history given in Table 2.3 and Figure 2.7 shall be recorded as an unsuccessful test. The mean residual capacity of the anchors in the test series shall be at least 160% of the reduced load  $V_{eq,reduced}$ . Successful completion of the cyclic history with reduced load values and fulfilment of the residual capacity requirement of this section shall be recorded together with a reduction factor  $\Gamma_{V,seis,C1}$  as given by Equation (3.2).

$$\Gamma_{V,seis,C1} = \frac{V_{eq,reduced}}{V_{eq}} \quad (3.2)$$

The reduction factor  $\Gamma_{V,seis,C1}$  shall be used to determine the characteristic resistance for seismic loading according to 3.3.1.

The reduction factor  $\Gamma_{V,seis,C1}$  according to Equation (3.2) is valid for all embedment depths greater than the tested embedment depth. If more than one embedment depth has been tested the reduction factor  $\Gamma_{V,seis,C1}$  for an intermediate embedment depth may be determined by linear interpolation.

## 3.2 Assessment for category C2

### 3.2.1 General requirements

#### 3.2.1.1 Normalization of test results

The test results shall be normalised as follows:

Steel Failure

$$N_{u,m}(f_u) = N_{u,m,test} \cdot \left( \frac{f_u}{f_{u,test}} \right) \quad [\text{N}] \quad (3.3)$$

$$V_{u,m}(f_u) = V_{u,m,test} \cdot \left( \frac{f_u}{f_{u,test}} \right) \quad [\text{N}] \quad (3.4)$$

For anchors with a sleeve in the shear plane the normalization shall be calculated as follows:

$$V_{u,m}(f_u) = V_{u,m,test} \cdot \left( \frac{f_u}{f_{u,test}} \cdot \frac{A_{s,bolt}}{A_{s,anchor}} + \frac{f_{u,sleeve}}{f_{u,sleeve,test}} \cdot \frac{A_{s,sleeve}}{A_{s,anchor}} \right) [\text{N}] \quad (3.5)$$

Bond Failure of bonded anchors

$$N_{u,m}(f_c) = N_{u,m,test} \cdot \left( \frac{f_c}{f_{c,test}} \right)^n \quad [\text{N}] \quad (3.6)$$

All other failure modes

$$N_{u,m}(f_c) = N_{u,m,test} \cdot \left( \frac{f_c}{f_{c,test}} \right)^{0.5} \quad [\text{N}] \quad (3.7)$$

where

$A_{s,bolt}$  = effective cross section of bolt [mm<sup>2</sup>];

$A_{s,sleeve}$  = effective cross section of sleeve [mm<sup>2</sup>];

$A_{s,anchor}$  =  $A_{s,bolt} + A_{s,sleeve}$  [mm<sup>2</sup>].

$N_{u,m}$  = normalized mean tension capacity [N];

$N_{u,m,test}$  = mean tension capacity from the test series [N];

$V_{u,m}$  = normalized mean shear capacity [N];

$V_{u,m,test}$  = mean shear capacity from the test series [N];

$f_c$  = mean compressive strength of concrete to which the capacity is to be normalized [N/mm<sup>2</sup>];

$f_{c,test}$  = mean compressive strength of concrete used at the time of testing [N/mm<sup>2</sup>];

$f_u$  = mean steel strength of bolt, threaded rod or insert to which the capacity is to be normalized [N/mm<sup>2</sup>];

$f_{u,sleeve}$  = mean steel strength of the sleeve to which the capacity is to be normalized [N/mm<sup>2</sup>];

$f_{u,sleeve,test}$  = ultimate steel strength of the sleeve of anchors used in the tests [N/mm<sup>2</sup>];

$f_{u,test}$  = ultimate mean steel strength of bolt, threaded rod or insert of anchors used in the tests [N/mm<sup>2</sup>];

$n$  = normalization factor to account for concrete strength; ETAG 001 Part 5, 6.0(b).

Adjustment for different steel strengths in Equation (3.3) to Equation (3.5) is not required if the anchors in all tests are taken from the same production lot.

If mixed failure modes occur in the test series C2.1, C2.3 and C2.5 the normalization shall be performed assuming that the failure mode, which was observed in the majority of tests in the test series, occurred in all tests.

### 3.2.1.2 Load/displacement behaviour

In the load/displacement curve for each anchor tested, a load plateau with a corresponding slip greater than 10% of the displacement at ultimate load, and/or a temporary drop in load of more than 5% of the ultimate load is not acceptable up to a load of 70% of the ultimate load in the single test.

This requirement shall be fulfilled in the test series C2.1a and C2.1b, and in the initial loading as well as in the residual capacity tests of test series C2.3 and C2.5. If this requirement is not fulfilled, the anchor is not suitable for use in category C2.

### 3.2.2 Assessment of tension test series C2.1

The following conditions apply:

1. Scatter of displacements:

$$CV(u(0,5 \cdot N_{u,m,C2.1})) \leq 40\% \quad (3.8)$$

with

CV = coefficient of variation in [%];

$u(0,5 \cdot N_{u,m,C2.1})$  = displacement of the anchor at 50% of mean ultimate load of test series C2.1a and b, i.e.  $N_{u,m,C2.1a}$  and  $N_{u,m,C2.1b}$ , respectively [mm].

If this condition is not fulfilled for one of the test series, the anchor is not suitable for use in category C2. It is allowed to increase the number of tests to fulfil this requirement. Note that if in a test series displacements of all anchors at the load  $0,5 N_{u,m}$  are smaller than or equal to 0,4 mm the above condition on the scatter of the displacement does not apply.

2. Ultimate load:

- a. Test series C2.1a in low strength concrete C20/25:

$$N_{u,m,C2.1a} \geq 0,8 \cdot N_{u,m,3} \quad (3.9)$$

with

$N_{u,m,C2.1a}$  = mean ultimate tension load from test series C2.1a [N];

$N_{u,m,3}$  = mean tension capacity from the tests according to ETAG 001 Part 1, Table 5.1, line 3 or Part 5, Table 5.6, line 3 [N];

If this condition is fulfilled,  $\gamma_{C2.1a} = 1,0$ . If the condition is not fulfilled, the reduction factor  $\gamma_{C2.1a}$  is determined for the test series C2.1a according to Equation (3.10).

$$\gamma_{C2.1a} = \frac{N_{u,m,C2.1a}}{0,8 \cdot N_{u,m,3}} \quad (3.10)$$

In Equations (3.9) and (3.10) the resistances from the tests according to ETAG 001 Part 1, Table 5.1, line 3 or Part 5, Table 5.6, line 3 shall be normalized according to Equation (3.3), Equation (3.6) or Equation (3.7), as applicable, to the strength in test series C2.1a.

- b. Test series C2.1b in high strength concrete C50/60:

$$N_{u,m,C2.1b} \geq 0,8 \cdot N_{u,m,4} \quad (3.11)$$

with

$N_{u,m,C2.1b}$  = mean ultimate tension load from test series C2.1b [N];

$N_{u,m,4}$  = mean tension capacity from the tests according to ETAG 001 Part 1, Table 5.1, line 4 or Part 5, Table 5.6, line 4 [N].

If this condition is fulfilled,  $\gamma_{C2.1b} = 1,0$ . If the condition is not fulfilled, the reduction factor  $\gamma_{C2.1b}$  is determined for the test series C2.1b according to Equation (3.12).

$$\gamma_{C2.1b} = \frac{N_{u,m,C2.1b}}{0,8 \cdot N_{u,m,4}} \quad (3.12)$$

In Equations (3.11) and (3.12) the resistances from the tests according to ETAG 001 Part 1, Table 5.1, line 4 or Part 5, Table 5.6, line 4 shall be normalized according to Equation (3.3), Equation (3.6) or Equation (3.7), as applicable, to the strength in test series C2.1b.

The reduction factor  $r_{C2.1}$  is determined according to Equation (3.13).

$$r_{C2.1} = \min(r_{C2.1a}; r_{C2.1b}) \quad (3.13)$$

3. Scatter of ultimate loads:

$$CV(N_u) \leq 20\% \quad (3.14)$$

If this condition is fulfilled for both test series C2.1a and C2.1b,  $S_{cv,C2.1a} = S_{cv,C2.1b} = 1,0$ . If this condition is not fulfilled in a test series, the factors  $S_{cv,C2.1a}$  and/or  $S_{cv,C2.1b}$  shall be calculated according to Equation (3.15) and Equation (3.16), respectively.

$$S_{cv,C2.1a} = \frac{1}{1 + (CV(N_{u,C2.1a}) - 20) \cdot 0,03} \quad (3.15)$$

$$S_{cv,C2.1b} = \frac{1}{1 + (CV(N_{u,C2.1b}) - 20) \cdot 0,03} \quad (3.16)$$

where  $CV(N_{u,C2.1a})$  and  $CV(N_{u,C2.1b})$  are the coefficients of variation of the ultimate loads in test series C2.1a and C2.1b, respectively.

The factor  $S_{cv,C2.1}$  is determined as given in Equation (3.17):

$$S_{cv,C2.1} = \min(S_{cv,C2.1a}; S_{cv,C2.1b}) \quad (3.17)$$

If  $CV(N_u)$  is larger than 30% in one test series, the anchor is not suitable for use in category C2. It shall be allowed to increase the number of tests in a test series to possibly fulfil this requirement.

### 3.2.3 Assessment of reference shear test series C2.2

If calculated values or results of tests according to ETAG 001 Part 1, Table 5.4, line 5 are taken as reference tests, this section does not apply. If test series C2.2 are performed for reference shear values the following conditions apply:

1. Failure mode:

If failure is caused by pullout or pull-through the anchor is not suitable for use in category C2. The test may be repeated with a larger embedment depth avoiding these failure modes.

2. Ultimate load:

$$V_{u,m,C2.2} \geq 0,8 \cdot V_{u,m,5} \quad (3.18)$$

with

$V_{u,m,C2.2}$  = mean ultimate shear load from test series C2.2 [N];

$V_{u,m,5}$  = mean shear capacity from the tests according to ETAG 001 Part 1, Table 5.4, line 5 [N].

If this condition is fulfilled,  $r_{C2.2} = 1,0$ . If this condition is not fulfilled, the factor  $r_{C2.2}$  shall be determined according to Equation (3.19).

$$r_{C2.2} = \frac{V_{u,m,C2.2}}{0,8 \cdot V_{u,m,5}} \quad (3.19)$$

In Equations (3.18) and (3.19) the resistances from the tests according to ETAG 001 Part 1, Table 5.4, line 5 shall be normalized according to Equation (3.4) or Equation (3.5), as applicable, to the strength in test series C2.2.

3. Scatter of ultimate loads:

$$CV(V_u) \leq 15\% \quad (3.20)$$

If this condition is fulfilled,  $S_{cv,C2.2} = 1,0$ . If this condition is not fulfilled, the factor  $S_{cv,C2.2}$  shall be determined according to Equation (3.21).

$$S_{cv,C2.2} = \frac{1}{1 + (CV(V_u) - 15) \cdot 0,03} \quad (3.21)$$

where  $CV(V_u)$  is the coefficient of variation of the ultimate loads in test series C2.2.

If  $CV(V_u)$  is larger than 30%, the anchor is not suitable for use in category C2.

### 3.2.4 Assessment of tests under pulsating tension load (test series C2.3)

The following conditions apply:

1. All anchors in a test series shall complete the pulsating tension load history specified in Figure 2.9 and Table 2.5. Failure of an anchor to develop the required resistance in any cycle prior to completing the loading history specified in Table 2.5 shall be recorded as an unsuccessful test. In case of an unsuccessful test, the test series shall be repeated with a reduced value  $N_{max, reduced, 1}$  until the requirement is fulfilled. In this case the reduction factor  $r_{C2.3a}$  shall be calculated according to Equation (3.22).

$$r_{C2.3a} = \frac{N_{max, reduced, 1}}{N_{max}} \quad (3.22)$$

with

$N_{max}$  = maximum tension load according to Equation (2.12) to Equation (2.14) [N].

$N_{max, reduced, 1}$  = reduced tension load to fulfil the requirement.

2. Displacements are assessed during the last cycle at  $0,5 \cdot N/N_{max}$  and at  $1,0 \cdot N/N_{max}$  or at  $0,5 \cdot N/N_{max, reduced, 1}$  and at  $1,0 \cdot N/N_{max, reduced, 1}$ , respectively, (refer to Figure 2.9). Displacements shall be reported in terms of the mean value.

To avoid excessive displacement of the anchor a displacement limit at the end of load cycling at  $0,5 \cdot N/N_{max}$  or  $0,5 \cdot N/N_{max, reduced, 1}$  (i.e. after 50 load cycles (see Figure 2.9 and Table 2.5)) is introduced for the assessment of anchors. Due to lack of sufficient test data this limit is assumed as  $u_{N, lim} = 7$  mm. The following condition shall be fulfilled:

$$u_m(0,5 \cdot N/N_{max}) \leq u_{N, lim} \quad (3.23)$$

with

$u_m(0,5 \cdot N/N_{max})$  = mean value of displacements of the anchor after load cycling at  $0,5 \cdot N/N_{max}$  or  $0,5 \cdot N/N_{max, reduced, 1}$  of test series C2.3 [mm];

$u_{N, lim}$  = 7 mm.

If this condition is not fulfilled repeat the tests with a reduced value  $N_{max, reduced, 2}$  until the requirement is fulfilled and calculate the reduction factor  $r_{C2.3b}$  according to Equation (3.24).

$$r_{C2.3b} = \frac{N_{max, reduced, 2}}{N_{max}} \quad (3.24)$$

with

$N_{max}$  = maximum tension load according to Equation (2.12) to Equation (2.14) [N];

$N_{max, reduced, 2}$  = reduced tension load to fulfil the requirement.

If the condition according to Equation (3.23) is fulfilled but a smaller displacement is intended it shall be permitted to repeat the tests with a reduced value  $N_{max, reduced}$ .

3. Residual capacity tests (all three conditions apply):

a. Scatter of displacement:

$$CV(u(0,5 \cdot N_{u,m,C2.3})) \leq 40\% \quad (3.25)$$

with

$u(0,5 \cdot N_{u,m,C2.3})$  = displacement of the anchor at 50% of the mean ultimate tension load from the residual capacity tests of test series C2.3. Only the displacement in the residual capacity test is taken, i.e., the displacement that occurred during the cyclic loading is neglected [mm].

$N_{u,m,C2.3}$  = mean ultimate tension load from residual capacity tests of test series C2.3 [N].

If this condition is not fulfilled, the anchor is not suitable for use in category C2.

b. Ultimate load:

$$N_{u,m,C2.3} \geq 0,9 \cdot N_{u,m,C2.1a} \quad (3.26)$$

with

$N_{u,m,C2.1a}$  = mean ultimate tension load from test series C2.1a [N];

$N_{u,m,C2.3}$  = mean ultimate tension load from residual capacity tests of test series C2.3 [N].

If this condition is fulfilled,  $r_{C2.3c} = 1,0$ . If this condition is not fulfilled, the factor  $r_{C2.3c}$  shall be determined according to Equation (3.27).

$$r_{C2.3c} = \frac{N_{u,m,C2.3}}{0,9 \cdot N_{u,m,C2.1a}} \quad (3.27)$$

In Equations (3.26) and (3.27) the resistances from test series C2.1a shall be normalized according to Equation (3.3), Equation (3.6) or Equation (3.7), as applicable, to the strength in test series C2.3.

Alternatively, the test series C2.3 may be repeated with a reduced value of  $N_{max}$  until the requirement given in Equation (3.26) is fulfilled.

c. Scatter of ultimate loads:

$$CV(N_u) \leq 20\% \quad (3.28)$$

If this condition is fulfilled,  $S_{cv,C2.3} = 1,0$ . If this condition is not fulfilled,  $S_{cv,C2.3}$  shall be determined according to Equation (3.29).

$$S_{cv,C2.3} = \frac{1}{1 + (CV(N_u) - 20) \cdot 0,03} \quad (3.29)$$

where  $CV(N_u)$  is the coefficient of variation of the ultimate loads in the residual capacity tests in test series C2.3.

If  $CV(N_u)$  is larger than 30%, the anchor is not suitable for use in category C2.

The reduction factor  $r_{C2.3}$  resulting from the pulsating tension test series C2.3 is determined according to Equation (3.30).

$$r_{C2.3} = \min(r_{C2.3a}, r_{C2.3b}) \cdot r_{C2.3c} \quad (3.30)$$

Report the displacements after successful completion at  $0,5 \cdot N/N_{max}$  and  $1,0 \cdot N/N_{max}$  or at  $0,5 \cdot N/N_{max, reduced}$  and  $1,0 \cdot N/N_{max, reduced}$  in case the tests are repeated with a reduced load value, as applicable.

### 3.2.5 Assessment of tests under alternating shear load (test series C2.4)

The following conditions apply:

1. All anchors in a test series shall complete the alternating shear load history specified in Figure 2.10 and Table 2.6. Failure of an anchor to develop the required resistance in any cycle prior to completing the loading history specified in Table 2.6 shall be recorded as an unsuccessful test. In case of an unsuccessful test, the test series shall be repeated with a reduced value  $V_{max, reduced, 1}$  until the requirement is fulfilled. In this case the reduction factor  $r_{C2.4a}$  shall be calculated according to Equation (3.31).

$$r_{C2.4a} = \frac{V_{max, reduced, 1}}{V_{max}} \quad (3.31)$$

with

$$\begin{aligned} V_{max} &= \text{maximum shear load according to Equation (2.15) or Equation (2.17) [N];} \\ V_{max, reduced, 1} &= \text{reduced shear load to fulfil the requirement [N].} \end{aligned}$$

2. Displacements are assessed during the last cycle at  $\pm 0,5 \cdot V/V_{max}$  and  $\pm 1,0 \cdot V/V_{max}$  or  $\pm 0,5 \cdot V/V_{max, reduced, 1}$  and  $\pm 1,0 \cdot V/V_{max, reduced, 1}$  (refer to Figure 2.10). Displacements shall be reported as the maximum of the mean of the absolute values in the positive loading direction and the mean of the absolute values in the negative loading direction.

To avoid excessive displacement of the anchor a displacement limit at the end of load cycling at  $\pm 0,5 \cdot V/V_{max}$  (i.e. at load cycle 50 (see Figure 2.10 and Table 2.6)) is introduced for the assessment of anchors. Due to lack of sufficient test data this limit is assumed as  $u_{V, lim} = 7$  mm. The following condition shall be fulfilled:

$$u_m(0,5 \cdot V/V_{max}) \leq u_{V, lim} \quad (3.32)$$

with

$$\begin{aligned} u_m(0,5 \cdot V/V_{max}) &= \max(|u_m(+0,5 \cdot V/V_{max})|; |u_m(-0,5 \cdot V/V_{max})|); \text{ maximum of the mean value of} \\ &\text{ displacements of the anchor after load cycling at } +0,5 \cdot V/V_{max} \text{ and the mean value} \\ &\text{ of displacements of the anchor after load cycling at } -0,5 \cdot V/V_{max} \text{ of test series C2.4;} \\ &\text{ if the tests have been performed with } V_{max, reduced, 1} \text{ replace } V_{max} \text{ by } V_{max, reduced, 1} \\ &\text{ [mm];} \\ u_{V, lim} &= 7 \text{ mm.} \end{aligned}$$

If the condition is not fulfilled repeat the tests with a reduced value  $V_{max, reduced, 2}$  until the requirement is fulfilled. Determine the corresponding reduction factor  $r_{C2.4b}$  in accordance with Equation (3.33).

$$r_{C2.4b} = \frac{V_{max, reduced, 2}}{V_{max}} \quad (3.33)$$

with

$$\begin{aligned} V_{max} &= \text{maximum shear load according to Equation (2.15) or Equation (2.17) [N];} \\ V_{max, reduced, 2} &= \text{reduced shear load to fulfil the requirement [N].} \end{aligned}$$

If the condition according to Equation (3.32) is fulfilled but a smaller displacement is intended it shall be permitted to either repeat the tests with a reduced value  $V_{max, reduced}$ .

3. Residual capacity tests (both conditions apply):

a. Failure mode:

If failure is caused by pullout or pull-through the anchor is not suitable for use in category C2. The tests may be repeated with a larger embedment depth avoiding these failure modes.

b. Ultimate load:

$$V_{u,m,C2.4} \geq 0,95 \cdot V_{u,m,C2.2} \quad (3.34)$$

with

$V_{u,m,C2.4}$  = mean ultimate shear load from residual capacity tests of test series C2.4 [N].

$V_{u,m,C2.2}$  = mean ultimate shear load from residual capacity tests of test series C2.2 [N].

If this condition is fulfilled,  $r_{C2.4c} = 1,0$ . If this condition is not fulfilled, the factor  $r_{C2.4c}$  shall be determined according to Equation (3.35).

$$r_{C2.4c} = \frac{V_{u,m,C2.4}}{0,95 \cdot V_{u,m,C2.2}} \quad (3.35)$$

In Equations (3.34) and (3.35) the resistances from test series C2.2 shall be normalized according to Equation (3.4) or Equation (3.5), as applicable, to the strength in test series C2.4.

Alternatively, the test series C2.4 may be repeated with a reduced value of  $V_{max}$  until the requirement given in Equation (3.34) is fulfilled.

c. Scatter of ultimate loads:

$$CV(V_u) \leq 15\% \quad (3.36)$$

If this condition is fulfilled,  $S_{cv,C2.4} = 1,0$ . If this condition is not fulfilled,  $S_{cv,C2.4}$  shall be determined according to Equation (3.37).

$$S_{cv,C2.4} = \frac{1}{1 + (CV(V_u) - 15) \cdot 0,03} \quad (3.37)$$

where  $CV(V_u)$  is the coefficient of variation of the ultimate loads in the residual capacity tests in test series C2.4.

If  $CV(V_u)$  is larger than 30%, the anchor is not suitable for use in category C2.

The reduction factor  $r_{C2.4}$  resulting from the alternating shear load test series C2.4 is determined according to Equation (3.38).

$$r_{C2.4} = \min(r_{C2.4a}; r_{C2.4b}) \cdot r_{C2.4c} \quad (3.38)$$

Report the displacements after successful completion at  $\pm 0,5 \cdot V/V_{max}$  and  $\pm 1,0 \cdot V/V_{max}$  or at  $\pm 0,5 \cdot V/V_{max, reduced}$  and  $\pm 1,0 \cdot V/V_{max, reduced}$  in case the tests are repeated with a reduced shear load, as applicable.

### 3.2.6 Assessment of tests under tension load with varying crack width (test series C2.5)

The following conditions apply:

1. All anchors in the test series shall complete the varying crack width history under tension load specified in Figure 2.12 and Table 2.7. Failure of an anchor to develop the required resistance in any cycle prior to completing the crack cycling history specified in Table 2.7 shall be recorded as an unsuccessful test. In case of an unsuccessful test, the test series shall be repeated with proportionally reduced values of  $N_{w1}$  and  $N_{w2}$ , i.e.  $N_{w1, reduced, 1}$  and  $N_{w2, reduced, 1}$ , respectively, until the requirement is fulfilled. The corresponding reduction factor  $r_{C2.5a}$  shall be calculated according to Equation (3.39).



$$r_{C2.5a} = \frac{N_{w2, reduced, 1}}{N_{w2}} \quad (3.39)$$

with

$N_{w2}$  = tension load according to Equation (2.23) to Equation (2.25) as applicable [N];  
 $N_{w2, reduced, 1}$  = reduced tension load to fulfil the requirement.

2. Displacements are assessed during the last cycle at  $w = 0,5$  mm and  $w = 0,8$  mm (see Figure 2.12). Displacements shall be reported in terms of the mean value.

To avoid excessive displacement of the anchor a displacement limit at the end of cycling at  $w = 0,5$  mm (i.e. at the end of cycle 45 (see Figure 2.12 and Table 2.7)) is introduced for the assessment of anchors. Due to lack of sufficient test data this limit is assumed as  $u_{N, lim} = 7$  mm. The following condition shall be fulfilled:

$$u_m(\Delta w = 0,5) \leq u_{N, lim} \quad (3.40)$$

with

$u_m (w = 0,5)$  = mean value of displacements of the anchor at the end of cycling at  $w = 0,5$  mm of test series C2.5 [mm];  
 $u_{N, lim}$  = 7 mm.

If this condition is not fulfilled repeat the tests with proportionally reduced values of  $N_{w1}$  and  $N_{w2}$ , i.e.  $N_{w1, reduced, 2}$  and  $N_{w2, reduced, 2}$ , respectively, until the requirement is fulfilled and calculate the reduction factor  $r_{C2.5b}$  according to Equation (3.41).

$$r_{C2.5b} = \frac{N_{w2, reduced, 2}}{N_{w2}} \quad (3.41)$$

with

$N_{w2}$  = tension load according to Equation (2.23) to Equation (2.25) [N];  
 $N_{w2, reduced, 2}$  = reduced tension load to fulfil the requirement.

If the condition according to Equation (3.40) is fulfilled but a smaller displacement is intended it shall be permitted to repeat the tests with proportionally reduced values  $N_{w1, reduced, 2}$  and  $N_{w2, reduced, 2}$ .

3. Residual capacity tests (all three conditions apply):

- a. Scatter of displacement:

$$CV(u(0,5 \cdot N_{u, m, C2.5})) \leq 40\% \quad (3.42)$$

with

$u(0,5 \cdot N_{u, m, C2.5})$  = displacement of the anchor at 50% of the mean ultimate tension load from the residual capacity tests of test series C2.5; displacement in the residual capacity test only, i.e., neglecting the displacement that occurred during the crack cyclic [mm].  
 $N_{u, m, C2.5}$  = mean ultimate tension load from residual capacity tests of test series C2.5 [N].

If this condition is not fulfilled, the anchor is not suitable for use in category C2.

- b. Ultimate load:

$$N_{u, m, C2.5} \geq 0,9 \cdot N_{u, m, C2.1a} \quad (3.43)$$

with

$N_{u, m, C2.1a}$  = mean ultimate tension load from test series C2.1a [N];  
 $N_{u, m, C2.5}$  = mean ultimate tension load from residual capacity tests of test series C2.5 [N].

If this condition is fulfilled,  $r_{C2.5c} = 1.0$ . If this condition is not fulfilled, the factor  $r_{C2.5c}$  shall be determined according to Equation (3.44).

$$r_{C2.5c} = \frac{N_{u,m,C2.5}}{0,9 \cdot N_{u,m,C2.1a}} \quad (3.44)$$

In Equations (3.43) and (3.44) the resistances from test series C2.1a shall be normalized according to Equation (3.3), Equation (3.6) or Equation (3.7), as applicable, to the strength in test series C2.5.

Alternatively, the test series C2.5 may be repeated with a reduced value of  $N_{max}$  until the requirement given in Equation (3.43) is fulfilled.

c. Scatter of ultimate loads:

$$CV(N_u) \leq 20\% \quad (3.45)$$

If this condition is fulfilled,  $S_{cv,C2.5} = 1.0$ . If this condition is not fulfilled,  $S_{cv,C2.5}$  shall be determined according to Equation (3.46).

$$\beta_{cv,C2.5} = \frac{1}{1 + (CV(N_u) - 20) \cdot 0,03} \quad (3.46)$$

If  $CV(N_u)$  is larger than 30%, the anchor is not suitable for use in category C2.

The reduction factor  $r_{C2.5}$  resulting from the varying crack width test series C2.3 is determined according to Equation (3.47).

$$r_{C2.5} = \min(r_{C2.5a}; r_{C2.5b}) \cdot r_{C2.5c} \quad (3.47)$$

Report the displacements after successful completion at the end of crack cycling at  $w = 0,5$  mm and  $w = 0,8$  mm.

### 3.2.7 Determination of decisive reduction factors for seismic category C2

#### 3.2.7.1 Tension

The reduction factors  $r_{N,seis,C2}$  and  $S_{cv,N,C2}$  are determined according to Equations (3.48) and (3.49), respectively.

$$r_{N,seis,C2} = r_{C2.1} \cdot \min(r_{C2.3}; r_{C2.5}) \quad (3.48)$$

where

$r_{C2.1}$  = reduction factor  $r$  according to 3.2.2;

$r_{C2.3}$  = reduction factor  $r$  according to 3.2.4;

$r_{C2.5}$  = reduction factor  $r$  according to 3.2.6.

$$S_{cv,N,C2} = \min(S_{cv,C2.1}; S_{cv,C2.3}; S_{cv,C2.5}) \quad (3.49)$$

where

1  $S_{cv,C2.1}$  = reduction factor  $S_{cv}$  accounting for large scatter according to 3.2.2;

$S_{cv,C2.3}$  = reduction factor  $S_{cv}$  accounting for large scatter according to 3.2.4;

$S_{cv,C2.5}$  = reduction factor  $S_{cv}$  accounting for large scatter according to 3.2.6.

The reduction factors according to Equation (3.48) and Equation (3.49) are valid for anchors with the tested embedment depth and all smaller embedment depths.

If anchors with more than one embedment depth have been tested and different failure modes are observed in these tests then different reduction factors for steel and pullout (bond) failure may be obtained.

The reduction factors  $\Gamma_{N,seis,C2}$  and  $S_{cv,N,C2}$  shall be used to determine the characteristic resistances under seismic loading according to 3.3.2.1.

### 3.2.7.2 Shear

The reduction factors  $\Gamma_{V,seis,C2}$  and  $S_{cv,V,C2}$  are determined according to Equations (3.50) and (3.51), respectively.

$$\Gamma_{V,seis,C2} = \Gamma_{C2.2} \cdot \Gamma_{C2.4} \quad (3.50)$$

where

$\Gamma_{C2.2}$  = reduction factor  $\Gamma$  according to 3.2.3;

$\Gamma_{C2.4}$  = reduction factor  $\Gamma$  according to 3.2.5.

$$S_{cv,V,C2} = \min(S_{cv,C2.2}; S_{cv,C2.4}) \quad (3.51)$$

where

$S_{cv,C2.2}$  = reduction factor  $S_{cv}$  accounting for large scatter according to 3.2.3;

$S_{cv,C2.4}$  = reduction factor  $S_{cv}$  accounting for large scatter according to 3.2.5;

The reduction factors according to Equation (3.50) and Equation (3.51) are valid for anchors with the tested embedment depth and all larger embedment depths. If more than one embedment depth has been tested the reduction factors  $\Gamma_{V,seis,C2}$  and  $S_{cv,V,C2}$  for an intermediate embedment depth may be determined by linear interpolation.

The reduction factors  $\Gamma_{V,seis,C2}$  and  $S_{cv,V,C2}$  shall be used to determine the characteristic resistances under seismic loading according to 3.3.2.2.

## 3.3 Characteristic values for seismic design

In this assessment it is assumed that the characteristic resistances under seismic action for concrete failure modes (concrete cone breakout in tension and concrete edge breakout and pryout failure in shear) are covered in the design method by applying reduction factors to the corresponding characteristic resistances under non-seismic loading conditions.

### 3.3.1 Seismic performance category C1

#### 3.3.1.1 Tension

The characteristic resistances as determined below are valid for anchors with the tested embedment depth and all smaller embedment depths.

##### 3.3.1.1.1 All anchors except bonded anchors

###### a. Steel failure caused reduction:

The characteristic resistances for steel tension and pullout under seismic loading, i.e.  $N_{Rk,s,seis}$  and  $N_{Rk,p,seis}$ , respectively, to be reported in the ETA are determined as follows:

$$N_{Rk,s,seis} = \Gamma_{N,seis,C1} \cdot N_{Rk,s} \quad [\text{kN}] \quad (3.52)$$

$$N_{Rk,p,seis} = \Gamma_{N,seis,C1} \cdot N_{Rk,p} \quad [\text{kN}] \quad (3.53)$$

$$N_{Rk,p,seis} = \Gamma_{N,seis,C1} \cdot N_{Rk,c} \quad [\text{kN}] \quad (\text{if no pullout failure occurs for static loading}) \quad (3.54)$$

where

$N_{Rk,c}$  = characteristic concrete cone resistance in cracked concrete for static loading [kN];

$N_{Rk,p}$  = characteristic pullout resistance in cracked concrete as reported in the ETA for static loading [kN];

$N_{Rk,s}$  = characteristic steel tension resistance as reported in the ETA for static loading [kN];

$\Gamma_{N,seis,C1}$  = reduction factor  $\Gamma$  according to 3.1.1.

b. Pullout failure caused reduction:

The characteristic resistances for steel tension and pullout under seismic loading, i.e.  $N_{Rk,s,seis}$  and  $N_{Rk,p,seis}$ , respectively, to be reported in the ETA are determined as follows:

$$N_{Rk,s,seis} = N_{Rk,s} \quad [\text{kN}] \quad (3.55)$$

$$N_{Rk,p,seis} = \Gamma_{N,seis,C1} \cdot N_{Rk,p} \quad [\text{kN}] \quad (3.56)$$

$$N_{Rk,p,seis} = \Gamma_{N,seis,C1} \cdot N_{Rk,c} \quad [\text{kN}] \quad (\text{if no pullout failure occurs for static loading}) \quad (3.57)$$

where  $N_{Rk,c}$ ,  $N_{Rk,p}$ ,  $N_{Rk,s}$ , and  $\Gamma_{N,seis,C1}$  are given in Equation (3.52) to Equation (3.54).

### 3.3.1.1.2 Bonded anchors:

a. Steel failure caused reduction:

The characteristic resistances for steel tension and pullout (bond) under seismic loading, i.e.  $N_{Rk,s,seis}$  and  $\dagger_{Rk,seis}$ , respectively, to be reported in the ETA are determined as follows:

$$N_{Rk,s,seis} = \Gamma_{N,seis,C1} \cdot N_{Rk,s} \quad [\text{kN}] \quad (3.58)$$

$$\dagger_{Rk,seis} = \Gamma_{N,seis,C1} \dagger_{Rk,base} \quad [\text{kN}] \quad (3.59)$$

where

$N_{Rk,s}$  = characteristic steel tension resistance as reported in the ETA for static loading [kN];

$\dagger_{Rk,base}$  = basic bond strength  $\dagger_{Rk}^0$  from tests according to ETAG 001, Part 5, Table 5.1, line 3 applying  $\alpha_1$  to  $\alpha_4$  (i.e. reduction factors regarding “uncontrolled slip”, maximum long term temperature, maximum short term temperature, and durability) as defined in ETAG 001, Part 5, Section 6 and the reduction resulting from tests according to ETAG 001, Part 5, Table 5.1, line 6 (i.e. reduction resulting from sustained load); however, the reduction resulting from tests according to ETAG 001, Part 5, Table 5.1, line 5 (i.e. reduction resulting from functioning in crack movement) may not be applied [N/mm<sup>2</sup>]

$\Gamma_{N,seis,C1}$  = reduction factor  $\Gamma$  according to 3.1.1.

b. Pullout failure caused reduction:

The characteristic resistances for steel tension and pullout (bond) under seismic loading, i.e.  $N_{Rk,s,seis}$  and  $\dagger_{Rk,seis}$ , respectively, to be reported in the ETA are determined as follows:

$$N_{Rk,s,seis} = N_{Rk,s} \quad [\text{kN}] \quad (3.60)$$

$$\dagger_{Rk,seis} = \Gamma_{N,seis,C1} \dagger_{Rk,base} \quad [\text{kN}] \quad (3.61)$$

with  $N_{Rk,s}$ ,  $\dagger_{Rk,base}$  and  $\Gamma_{N,seis,C1}$  as defined in Equation (3.58) and Equation (3.59).

### 3.3.1.2 Shear

The characteristic shear resistance for steel under seismic loading,  $V_{Rk,s,seis}$ , to be reported in the ETA is determined as follows:

$$V_{Rk,s,seis} = \Gamma_{V,seis,C1} \cdot V_{Rk,s} \quad [\text{kN}] \quad (3.62)$$

where

$V_{Rk,s}$  = characteristic shear resistance as reported in the ETA for static loading [kN];

$\Gamma_{V,seis,C1}$  = reduction factor  $\Gamma$  according to 3.1.2.

The value  $V_{Rk,s,seis}$  according to Equation (3.62) is valid for all embedment depths greater than the tested embedment depth. If more than one embedment depth has been tested the value  $V_{Rk,s,seis}$  for an intermediate embedment depth may be determined by linear interpolation.

### 3.3.2 Seismic performance category C2

The characteristic values reported in the ETA are calculated as follows:

### 3.3.2.1 Tension loading

The characteristic resistances as determined below are valid for anchors with the tested embedment depth and all smaller embedment depths.

#### 3.3.2.1.1 All anchors except bonded anchors

a) Steel failure caused reduction:

The characteristic resistances for steel tension and pullout under seismic loading, i.e.  $N_{Rk,s,seis}$  and  $N_{Rk,p,seis}$ , respectively, to be reported in the ETA are determined as follows:

$$N_{Rk,s,seis} = \gamma_{N,seis,C2} \cdot S_{cv,N,C2} \cdot N_{Rk,s} \quad [\text{kN}] \quad (3.63)$$

$$N_{Rk,p,seis} = \gamma_{N,seis,C2} \cdot S_{cv,N,C2} \cdot N_{Rk,0} \quad [\text{kN}] \quad (3.64)$$

where

$N_{Rk,0}$  = characteristic value of test series ETAG 001 Part 1, Table 5.1, lines 3 and 4 (normalized according to Equation (3.3) to Equation (3.7) to the compressive strength of concrete (measured on cylinders) of  $f_c = 20 \text{ N/mm}^2$ ) [kN];

$N_{Rk,s}$  = characteristic steel tension resistance as reported in the ETA for static loading [kN];

$\gamma_{N,seis,C2}$  = reduction factor  $\gamma$  as determined in Equation (3.48);

$S_{cv,N,C2}$  = reduction factor  $S_{cv}$  accounting for large scatter as determined in Equation (3.49).

b) Pullout failure caused reduction:

The characteristic resistances for steel tension and pullout under seismic loading, i.e.  $N_{Rk,s,seis}$  and  $N_{Rk,p,seis}$ , respectively, to be reported in the ETA are determined as follows:

$$N_{Rk,s,seis} = N_{Rk,s} \quad [\text{kN}] \quad (3.65)$$

$$N_{Rk,p,seis} = \gamma_{N,seis,C2} \cdot S_{cv,N,C2} \cdot N_{Rk,0} \quad [\text{kN}] \quad (3.66)$$

with  $N_{Rk,0}$ ,  $N_{Rk,s}$ ,  $\gamma_{N,seis,C2}$  and  $S_{cv,N,C2}$  as given in Equation (3.63) and Equation (3.64).

#### 3.3.2.1.2 Bonded anchors

a) Steel failure

The characteristic resistance for steel tension  $N_{Rk,s,seis}$  to be reported in the ETA is determined as follows:

$$N_{Rk,s,seis} = \gamma_{N,seis,C2} \cdot S_{cv,N,C2} \cdot N_{Rk,s} \quad [\text{kN}] \quad (3.67)$$

where

$N_{Rk,s}$  = characteristic steel tension resistance as reported in the ETA for static loading [kN];

$\gamma_{N,seis,C2}$  = reduction factor  $\gamma$  as determined in Equation (3.48) for tests in which steel failure occurred;

$S_{cv,N,C2}$  = reduction factor  $S_{cv}$  accounting for large scatter as determined in Equation (3.49) for tests in which steel failure occurred.

b) Pullout (bond) failure

If pullout (bond) failure for bonded anchors is given in terms of a characteristic bond resistance the corresponding resistance under seismic loading  $\dagger_{Rk,seis}$  is determined as follows:

$$\dagger_{Rk,seis} = \gamma_{N,seis,C2} \cdot S_{cv,N,C2} \cdot \dagger_{Rk,base} \quad [\text{N/mm}^2] \quad (3.68)$$

with  $\dagger_{Rk,base}$  as given in Equation (3.59) and

$\gamma_{N,seis,C2}$  = reduction factor  $\gamma$  as determined in Equation (3.48) for tests in which pullout (bond) failure occurred;

$S_{cv,N,C2}$  = reduction factor  $S_{cv}$  accounting for large scatter as determined in Equation (3.49) for tests in which pullout (bond) failure occurred.

### 3.3.2.2 Shear loading

Under shear loading only steel failure is considered in the evaluation. Pryout and concrete edge failure are taken into account in the design provisions.

The characteristic steel shear resistance under seismic shear loading,  $V_{Rk,s,seis}$ , to be reported in the ETA is determined as follows:

$$V_{Rk,s,seis} = \gamma_{V,seis,C2} \cdot S_{cv,V,C2} \cdot V_{Rk,0} \quad [\text{kN}] \quad (3.69)$$

where

$V_{Rk,0}$  = characteristic resistance for steel failure given in the ETA for static loading [kN];

$\gamma_{V,seis,C2}$  = reduction factor  $\gamma$  according to Equation (3.50);

$S_{cv,V,C2}$  = reduction factor  $S_{cv}$  accounting for large scatter according to Equation (3.51).

The characteristic resistance according to Equation (3.69) is valid for anchors with the tested embedment depth and all larger embedment depths. If more than one embedment depth has been tested the characteristic resistance for an intermediate embedment depth may be determined by linear interpolation.

### 3.3.2.3 Partial safety factor $\chi_{M,seis}$

The recommended partial safety factors under seismic action ( $\gamma_{M,seis}$ ) are the same as for static loading.

### 3.3.2.4 Displacements

The displacement values reported in the ETA are determined as given in Table 3.1.

**Table 3.1 Displacement information**

Displacement <sup>1)</sup>	Obtained from
$\delta_{N,seis}(DLS)$	Maximum of the mean value of displacements reported at $0,5 \cdot N/N_{max}$ or $0,5 \cdot N/N_{max,reduced}$ (as applicable) of C2.3 tests and the mean value of displacements reported at $w = 0,5$ mm of C2.5 tests.
$\delta_{N,seis}(ULS)$	Maximum of the mean value of displacements reported at $1,0 \cdot N/N_{max}$ or $1,0 \cdot N/N_{max,reduced}$ (as applicable) of C2.3 tests and the mean value of displacements reported at $w = 0,8$ mm of C2.5 tests.
$\delta_{V,seis}(DLS)$	Mean value of displacements reported at $0,5 \cdot V/V_{max}$ or $0,5 \cdot V/V_{max,reduced}$ (as applicable) of C2.4 tests.
$\delta_{V,seis}(ULS)$	Mean value of displacements reported at $1,0 \cdot V/V_{max}$ or $1,0 \cdot V/V_{max,reduced}$ (as applicable) of C2.4 tests.
<sup>1)</sup> DLS – Damage Limitation State (see EN 1998-1:2004, 2.2.1) ULS – Ultimate Limit State (see EN 1998-1:2004, 2.2.1)	

### 3.3.3 Content of the European Technical Approval (ETA)

In the ETA the seismic performance category C1 or C2 for which the anchor has been assessed shall be stated on the title page in the description of “Generic type and use of construction product” as well as in section 2.2 “Methods of verification”. The design provisions (EOTA Technical Report TR xxx “Design of Metal Anchors Under Seismic Actions” [4] or the corresponding CEN document) shall be stated in the section 4.2.1 “Design of anchorage”. It shall be stated that the recommended use of anchors according to the seismic performance categories C1 or C2 is given in the referenced design provisions.

An example of the information for characteristic values for design of anchors under seismic action is shown in Table 3.2 and Table 3.3.

**Table 3.2 Sample ETA seismic design information for seismic performance category C1**

<b>Anchor type</b>		<b>M...</b>	<b>...</b>	<b>M...</b>
<i>(static design information)</i>		XX		XX
<b>Seismic design information</b>				
$N_{Rk,s,seis}$	[kN]	XX		XX
$\gamma_{Ms,seis}^{1)}$	[-]	XX		XX
$N_{Rk,p,seis}$	[kN]	XX		XX
$(\tau_{Rk,seis}$ for bonded anchors)	[N/mm <sup>2</sup> ]			
$\gamma_{Mp,seis}^{1)}$	[-]	XX		XX
$V_{Rk,s,seis}$	[kN]	XX		XX
$\gamma_{Ms,seis}^{1)}$	[-]	XX		XX

1) The recommended partial safety factors under seismic action ( $\gamma_{M,seis}$ ) are the same as for static loading.

**Table 3.3 Sample ETA seismic design information for seismic performance category C2**

<b>Anchor type</b>		<b>M...</b>	<b>...</b>	<b>M...</b>
<i>(static design information)</i>		XX		XX
<b>Seismic design information</b>				
$N_{Rk,s,seis}^{2)}$	[kN]	XX		XX
$\gamma_{Ms,seis}^{3)}$	[-]	XX		XX
$N_{Rk,p,seis}^{2)}$	[kN]	XX		XX
$(\tau_{Rk,seis}$ for bonded anchors)	[N/mm <sup>2</sup> ]			
$\gamma_{Mp,seis}^{3)}$	[-]	XX		XX
$\delta_{N,seis(DLS)}^{1) 2)}$	[mm]	XX		XX
$\delta_{N,seis(ULS)}^{1)}$	[mm]	XX		XX
$V_{Rk,s,seis}^{2)}$	[kN]	XX		XX
$\gamma_{Ms,seis}^{3)}$	[-]	XX		XX
$\delta_{V,seis(DLS)}^{1) 2)}$	[mm]	XX		XX
$\delta_{V,seis(ULS)}^{1)}$	[mm]	XX		XX

DLS – Damage Limitation State (see EN 1998-1:2004, 2.2.1)  
 ULS – Ultimate Limit State (see EN 1998-1:2004, 2.2.1)

1) The listed displacements represent mean values.

2) A smaller displacement may be required in the design provisions stated in section “Design of Anchorage”, e.g. in the case of displacement sensitive fastenings or “rigid” supports. The characteristic resistance associated with such smaller displacement may be determined by linear interpolation or proportional reduction.

3) The recommended partial safety factors under seismic action ( $\gamma_{M,seis}$ ) are the same as for static loading.

#### 4 Test Report

In addition to the minimum requirements listed in ETAG 001, Annex A, the report shall include at least the following information regarding the optional seismic tests:

##### Test member

- Reinforcement ratio
- Drawing of test member (including dimensions and position of reinforcement)

## Test setup

- Loading device
- Type and positioning of crack measurement device(s)
- Particulars concerning restraining uplift in shear tests (where applicable)
- Verification method for anchor being located in crack over required length
- Method of crack creation
- Verification of approximately constant crack width throughout thickness of test member (where applicable)

## Measured values

- Frequency of load cycling (where applicable)
- (hairline) crack width before and after anchor installation
- Minimum and maximum loads in each cycling sequence of load cycling tests
- Annular gap of clearance hole for shear tests
- Crack width for residual capacity tests
- Alternating shear load cycling procedure
- Reduced load levels and reason for reduction (where applicable)
- Particulars of tests for category C1
  - Crack width  $U_w$
  - Anchor displacement as a function of number of load cycles
  - Constant load levels  $N_{eq}$ ,  $N_i$  and  $N_m$  on anchor and method of applying the load in test series C1.1
  - Constant load levels  $V_{eq}$ ,  $V_i$  and  $V_m$  on anchor and method of applying the load in test series C1.2
- Particulars of tests for category C2
  - Maximum loads  $N_{max}$  and  $V_{max}$  in test series C2.3 and C2.4, respectively
  - Type of loading cycles (sinusoidal or triangular) in test series C2.3
  - Anchor displacements at minimum and maximum load and crack width as a function of number of load cycles in test series C2.3 and C2.4
  - Anchor displacements at 0,5  $N/N_{max}$  and 1,0  $N/N_{max}$  in test series C2.3
  - Anchor displacements at 0,5  $V/V_{max}$  and 1,0  $V/V_{max}$  in test series C2.4
  - Constant load levels  $N_{w1}$  and  $N_{w2}$  on anchor and method of applying the load in test series C2.5
  - Frequency of crack cycling in test series C2.5
  - Initial compression force  $C_{ini}$  in test series C2.5
  - Compression force  $C_{test}$  in test series C2.5
  - Anchor displacements at minimum and maximum crack width and applied tension load as a function of number of crack cycles in test series C2.5
  - Anchor displacements at the end of crack cycling at level  $U_w = 0,5$  mm and  $U_w = 0,8$  mm in test series C2.5.

## 5 Abbreviation and Notation

### 5.1 Abbreviation

C1, C2	= seismic performance categories for prequalification of anchors
CV	= coefficient of variation
DLS	= Damage Limit State (see EN 1998-1:2004, 2.2.1)
ULS	= Ultimate Limit State (see EN 1998-1:2004, 2.2.1)

### 5.2 Notation

$a_g$	= design ground acceleration on type A ground (Ground types as defined in EN 1998-1, Table 3.1)
$A_g$	= cross section area of test member
$\underline{a}_{gR}$	= reference peak ground acceleration on type A ground (see EN 1998-1, 3.2.1)
$a_s$	= distance between anchor and nearest reinforcement bar
$A_s$	= stressed cross section area of steel element
$A_{s,re}$	= area of top and bottom reinforcement of the test member
$A_{c,ref}$	= $b_{ref} \cdot h_{ref}$ , reference cross section area for calculation of reinforcement ratio in 2.1.1
$b$	= width of test member



$b_{ref}$	= $4 \cdot h_{ef,i}$ , reference width for calculation of reinforcement ration in 2.1.1
$C_{ini}$	= initial centric compression force on concrete test member in test series C2.5
$C_{test}$	= centric compression force on concrete test member during crack cycling in test series C2.5
$d_s$	= diameter of the reinforcing bar (see Figure 2.2)
$h$	= thickness of test member
$h_{ef}$	= effective embedment depth of anchor
$h_{iz}$	= interaction zone between anchor and concrete
$h_{ltz}$	= effective load transfer zone of anchors
$h_{ref}$	= $2 \cdot h_{ef,i}$ , reference thickness of test member for calculation of reinforcement ratio in 2.1.1
$\ell_b$	= bond length (see Figure 2.2)
$\ell_{db}$	= de-bonding length (see Figure 2.2)
$n$	= normalization factor to account for concrete strength (ETAG 001 Part 5, 6.0(b))
$n_{cyc}$	= number of cycles
$N_{eq}$	= maximum tension load to be applied in the simulated seismic tension test series C1.1
$N_{eq, reduced}$	= reduced maximum tension load to be applied in the simulated seismic tension test series C1.1
$N_i$	= intermediate tension load to be applied in the simulated seismic tension test series C1.1
$N_m$	= minimum tension load to be applied in the simulated seismic tension test series C1.1
$N_{max}$	= maximum tension load to be applied in the pulsating tension load test series C2.3
$N_{Rk,s,seis}$	= characteristic steel tension resistance under seismic action reported in the ETA
$N_{Rk,p,seis}$	= characteristic tension pullout resistance under seismic action reported in the ETA
$N_{w1}$	= tension load to be applied in the serviceability range ( $w \leq 0,5$ mm) of the varying crack width test series C2.5
$N_{w2}$	= tension load to be applied in the suitability range ( $0,5$ mm $< w \leq 0,8$ mm) of the varying crack width test series C2.5
$S$	= soil factor (see e.g. EN 1998-1, 3.2.2)
$t$	= time
$T$	= torque
$T_{inst}$	= installation torque
$V_{eq}$	= maximum shear load to be applied in the simulated seismic shear test series C1.2
$V_{eq, reduced}$	= reduced maximum shear load to be applied in the simulated seismic shear test series C1.2
$V_i$	= intermediate shear load to be applied in the simulated seismic shear test series C1.2
$V_m$	= minimum shear load to be applied in the simulated seismic shear test series C1.2
$V_{max}$	= maximum shear load to be applied in the alternating shear load test series C2.4
$V_{Rk,s,seis}$	= characteristic steel shear resistance under seismic action reported in the ETA
$UW$	= crack width, which is additive to the width of the hairline crack after anchor installation but before anchor loading
$UW_{hef}$	= crack width at embedment depth $h_{ef}$
$UW_{top}$	= crack width at the top side of the test member in which the anchor is installed
$UW_{bottom}$	= crack width at the bottom side of the test member in which the anchor is installed
$\Gamma_{C2,x}$	= reduction factor resulting from assessment of test series C2.x
$N_{,seis}$	= seismic reduction factor for tension resistance
$V_{,seis}$	= seismic reduction factor for shear resistance
$S_{cv,N}$	= reduction factor for tension resistance resulting from large coefficients of variation
$S_{cv,V}$	= reduction factor for shear resistance resulting from large coefficients of variation
$u(N)$	= displacement of the anchor measured at tension load value $N$
$u_{N,lim}$	= displacement limit corresponding to excessive displacement of the anchor in the assessment of the results of test series C2.3 and C2.5

$U_{N,seis}$	= displacement of the anchor associated with the simulated seismic test series C2.3 and C2.5
$U_{V,lim}$	= displacement limit corresponding to excessive displacement of the anchor in the assessment of the results of test series C2.4
$U_{V,seis}$	= displacement of the anchor associated with the simulated seismic test series C2.4
$\chi_1$	= importance factor (see EN 1998-1, 4.2.5)
$\chi_{Mc}$	= partial factor for static loading and cracked concrete according to existing ETA
$\chi_{Ms}$	= partial factor for steel under static loading according to existing ETA
$\chi_{Mc,seis}$	= partial factor for concrete under seismic loading
$\chi_{Ms,seis}$	= partial factor for steel under seismic loading
$\dagger R_{k,seis1}$	= characteristic seismic bond resistance to be reported in the ETA
$\mu$	= reinforcement ratio

### 5.3 Definitions

non-structural element	= Building element, the failure of which results in medium consequence for loss of human life and considerable economic, social or environmental consequences, but does not result in the failure of the structure or part of the structure; examples: façade element, piping
structural element	= Building element, the failure of which may result in the failure of the structure or part of the structure; examples: column, beam, slab

## 6 References

- [1] EN 1998-1:2004, Eurocode 8: Design of structures for earthquake resistance – Part 1: General rules, seismic actions and rules for buildings, European Committee for Standardization (CEN), Brussels, Belgium, 2004.
- [2] EOTA TR 018, Assessment of torque-controlled bonded anchors, European Organization for Technical Approvals, Brussels, Belgium, 2003.
- [3] ISO 898-1, Mechanical properties of fasteners made of steel and alloy steel – Part 1: Bolts, screws and studs with specified property classes – Coarse thread and fine pitch thread, International Organization for Standardization, Geneva, Switzerland, 2009.