



red. Anm. Derzeit nicht in deutscher Fassung verfügbar.

ETAG 002

Edition November 1999

1st amendment: October 2001

2nd amendment: November 2005

3rd amendment: May 2012

GUIDELINE FOR EUROPEAN TECHNICAL APPROVAL FOR

STRUCTURAL SEALANT GLAZING KITS (SSGK)

Part 1: SUPPORTED AND UNSUPPORTED SYSTEMS

EOTA,
Kunstlaan 40 Avenue des Arts,
B - 1040 Brussels

SECTION ONE: INTRODUCTION.....	7
1 Preliminaries	7
1.1 Legal basis.....	7
1.2 Status of ETA Guidelines	7
2 Scope.....	9
2.1 Scope of Guideline.....	9
2.1.1 Structural sealant	11
2.2 Use categories	12
3 Terminology	13
3.1 Common terminology and abbreviations	13
3.1.1 Works and products	13
3.1.1.1 Construction works (and parts of works) (often simply referred to as “works”) (ID1.3.1)	13
3.1.1.2 Construction products (often simply referred to as “products”) (ID 1.3.2).....	13
3.1.1.3 Incorporation (of products in works) (ID 1.3.2).....	13
3.1.1.4 Intended use (ID 1.3.4).....	13
3.1.1.5 Execution (ETAG format)	13
3.1.2 Performance	13
3.1.2.1 Fitness for intended use (of products) (CPD 2.1).....	13
3.1.2.2 Serviceability (of works).....	13
3.1.2.3 Essential requirements (for works)	13
3.1.2.4 Performance (of works, parts of works or products) (ID 1.3.7).....	13
3.1.2.5 Actions (on works or parts of the works) (ID 1.3.6)	14
3.1.2.6 Classes (for Essential Requirements and for related product performances) (ID 1.2.1).....	14
3.1.3 ETAG format.....	14
3.1.3.1 Requirements (for works)	14
3.1.3.2 Methods of verification (for products).....	14
3.1.3.3 Specifications (for products)	14
3.1.4 Working life	14
3.1.4.1 Working life (of works or parts of the works) (ID 1.3.5(1))	14
3.1.4.2 Working life (of products).....	14
3.1.4.3 Economically reasonable working life (ID 1.3.5(2)).....	14
3.1.4.4 Maintenance (of works) (ID 1.3.3(1))	14
3.1.4.5 Normal maintenance (of works) (ID 1.3.3(2)).....	14
3.1.4.6 Durability (of products)	15
3.1.5 Conformity.....	15
3.1.5.1 Attestation and evaluation of conformity (of products)	15
3.1.5.2 Identification (of a product)	15
3.1.6 Abbreviations	15
3.1.6.1 Abbreviations concerning the Construction Products Directive	15
3.1.6.2 Abbreviations concerning approval:.....	15
3.1.6.3 General abbreviations:	15
3.2 Particular terminology:.....	16
SECTION TWO: GUIDANCE FOR ASSESSING FITNESS FOR USE	18
4 Requirements (for the works and indication of product-related aspects).....	18

4.0	Preamble.....	18
4.0.1	Economically reasonable working life.....	18
4.0.2	Initial considerations for the kit	18
4.0.3	Relation between the Essential Requirements and the product characteristics	19
4.1	ER1: Mechanical resistance and stability	19
4.2	ER2: Safety in case of fire.....	19
4.2.1	Reaction to fire.....	19
4.2.2	Resistance to fire	19
4.2.3	External fire performance	19
4.3	ER3: Hygiene, health and environment.....	20
4.4	ER4: Safety in use	20
4.4.1	Gravity	20
4.4.2	Effect of wind and snow load.....	20
4.4.3	Effects of building movements.....	20
4.4.4	Effect of temperature and barometric pressure	20
4.4.4.1	Effect of temperature.....	20
4.4.5	Table 2 - Relationship between the performance of the kit, its elements and the Essential Requirements	22
4.4.6	Effect of water	22
4.4.7	Accidental actions	23
4.4.8	Sill height	23
4.5	ER5: Protection against noise	23
4.6	ER6: Energy economy and heat retention.....	23
4.7	Durability.....	23
4.8	Accessories and ancillary products	23
4.9	Verifications necessary in case of interchange of components or suppliers.....	24
5	Methods of verification	26
5.0	Preamble.....	26
5.1	Verification methods related to the Essential Requirements.....	26
5.1.1	ER1: Mechanical resistance and stability	26
5.1.2	ER2: Safety in case of fire.....	26
5.1.2.1	Reaction to fire	26
5.1.2.2	Fire resistance.....	27
5.1.2.3	External fire performance	27
5.1.2.4	Partial collapse in case of fire.....	27
5.1.3	ER3: Hygiene, health and the environment	29
5.1.3.1	Performance with respect to air permeability, watertightness, wind resistance	29
5.1.3.2	Content and/or release of dangerous substances.....	30
5.1.4	ER4: Safety in use	30
5.1.4.1	Initial mechanical strength	32
5.1.4.2	Residual mechanical strength after artificial ageing.....	34
5.1.4.3	Mechanical devices	40
5.1.4.4	Tests of opening lights	42
5.1.4.5	Impact tests.....	42
5.1.4.6	Structural sealant - Physical properties	42
5.1.4.7	Method of calculating structural seal dimensions.....	47
5.1.4.8	Sill heights.....	47

5.1.4.9	Wind resistance.....	47
5.1.4.10	Partial collapse in case of fire	47
5.1.5	ER5: Protection against noise - Acoustic insulation.....	47
5.1.6	ER6: Energy economy and heat retention.....	48
5.1.6.1	Thermal insulation.....	48
5.1.6.2	Air permeability	48
5.1.7	Durability aspects.....	49
5.2	Verification methods related to the identification of the products	49
5.2.1	Structural sealant	49
5.2.1.1	Specific mass	49
5.2.1.2	Hardness.....	49
5.2.1.3	Thermogravimetric analysis.....	49
5.2.1.4	Colour	49
5.2.2	Anodised aluminium structural adhesion surface.....	49
5.2.2.1	Aluminium alloys	49
5.2.2.2	Anodising characteristics.....	50
5.2.2.3	Description of the anodising process.....	50
5.2.3	Glass adhesion surface.....	51
5.2.3.1	Identification of glass.....	51
5.2.3.2	Glass products	51
5.2.3.3	Coated glass	52
5.2.4	Stainless steel adhesion surface	53
5.3	Verifications necessary in case of interchange of components or suppliers.....	55
6	Assessing and judging the fitness of products for an intended use.....	55
6.0	Preamble.....	55
6.1	General - test result statistical interpretation.....	56
6.1.1	ER1: Mechanical resistance and stability - not relevant to SSGK.....	57
6.1.2	ER2: Safety in case of fire.....	57
6.1.3	ER3: Health, Hygiene and the Environment	58
6.1.4	ER4: Safety in Use.....	60
6.1.4.1	Initial Mechanical Strength	60
6.1.4.2	Residual strength after artificial ageing.....	60
6.1.4.3	Retaining Devices	60
6.1.4.6	Test of the structural sealant	61
6.1.5	ER 5: Protection against noise	62
6.1.7	Durability aspects.....	63
6.2	Verification methods related to the identification of the products	64
6.2.1	Structural sealant	64
6.2.2	Anodised aluminium structural adhesion surface.....	64
6.2.2.3	Description of the anodising process.....	64
6.2.3	Glass adhesion surface.....	65
6.2.4	Stainless steel adhesion surface -	65
6.2.5	ER2: Safety in case of fire.....	66
6.2.5.1	Reaction to fire	66
6.2.6	Fire resistance	66
6.2.7	External fire performance	66
6.3	Hygiene, health and the environment.....	66

6.3.1	Release of dangerous substances	66
7	Assumptions under which fitness for use is to be assessed	66
7.1	General	66
7.2	Design of the works.....	67
7.3	Execution of the works	67
7.3.1	Transport and storage.....	67
7.3.2	Installation.....	67
7.3.2.1	General	67
7.3.2.2	Weather sealing	68
7.4	Maintenance and repair.....	68
	SECTION THREE: ATTESTATION and EVALUATION OF CONFORMITY	69
8	Evaluation of conformity	69
8.1	EC decision.....	69
8.2	Responsibilities	70
8.2.1	Introduction	70
8.2.2	Tasks for the manufacturer	70
8.2.2.1	Factory production control (for the kit and structural sealant)	70
8.2.2.2	Testing of samples taken at the factory - Prescribed Test Plan (for kit and for structural sealant) 70	
8.2.2.3	Declaration of Conformity (System 2+) (for kit)	70
8.2.2.4	ITT for ETA on the kit	70
8.2.2.5	ITT for ETA on the structural sealant.....	70
8.3	Documentation (for kit and for structural sealant)	71
8.3.1	General	71
8.3.2	Detailed documentation.....	71
8.3.2.1	The ETA.....	71
8.3.2.2	Basic manufacturing process	71
8.3.2.3	Product and material specifications	71
8.3.2.4	Test plan as part of FPC.....	72
8.4	Prescribed test plan for the bonding workshop.....	79
8.4.1	General	79
8.4.2	Test procedure assessing a bonding workshop.....	79
8.5	Organisation of the certification - Route to CE marking	80
8.6	CE marking and information	80
	SECTION FOUR: ETA CONTENT	82
9	ETA content	82
9.1	ETA Content for SSGK.....	82
9.1.1	Performance	82
9.1.2	Specification.....	82
9.1.2.1	Dimensions	82
9.1.2.2	Components and accessories	83
9.1.3	Dangerous substances.....	84
9.1.4	Additional information.....	84
9.1.4.1	Content of the ETA technical file to be made available to other Approval Bodies (in addition to the information in the ETA).	84
9.1.4.2	Supplementary information to be provided to approval bodies (together with a copy of the ETA) for the purposes of evaluating conformity.	85
9.2	ETA content for structural sealant	85

9.2.1	Dangerous substances.....	86
9.2.2	Additional information.....	87
9.2.2.1	Content of the ETA technical file to be made available to other Approval Bodies (in addition to the information in the ETA).	87

SECTION ONE: INTRODUCTION

1 Preliminaries

1.1 Legal basis

This guideline for European Technical Approval has been established in full compliance with the provisions of Council Directive 89/106/EC (The Construction Products Directive) and has been established taking into account the following steps:

- Issuing of the final mandate by the EC : 18 April 1996.
- Adoption of the Guideline by EOTA (Executive Commission) : 2 June 1998.
- Endorsement of the document by the EC
 - SCC opinion of : 30 June - 1 July 1998.
 - EC letter of : 24 September 1998.
- SCC decision CONSTRUCT 00/427 concerning structural sealants as component of kit covered by existing ETAG
- Progress file endorsed by EOTA Excom (written endorsement) : November 2005

This document is published by the Member States in their official language or languages according to Art 11.3 of the CPD.

1.2 Status of ETA Guidelines

1.2.1 An ETA is one of the two main types of technical specifications in the sense of the EC Construction Products Directive (89/106/EEC). This means that Member States shall presume the approved products fit for their intended use, i.e. that they enable works in which they are used to satisfy the Essential Requirements for an economically reasonable working life, provided that:

- The works are properly designed and built
- The conformity of the products with the ETA has been properly attested

1.2.2 An ETA Guideline is a basis for ETAs, i.e. a basis for technical assessment of the fitness for an intended use¹.

ETA Guidelines express the common understanding of the approval bodies of the provisions of the EC Construction Products Directive and of the Interpretative Documents with regard to the products and uses concerned established within the framework of a mandate given by the EC Commission after consulting the EC Standing Committee for Construction.

1.2.3 ETA Guidelines are binding for the issuing of ETAs of the products concerned for an intended use when accepted by the EC Commission after consultation with the EC Standing Committee for Construction and published by the Member States in their official language or languages.

The applicability and the satisfaction of an ETA Guideline for a product and its intended use shall be assessed on a case-by-case basis by an authorised approval body.

Satisfaction of the provisions of an ETA Guideline (examinations, tests and evaluations) leads to a presumption of fitness for use only via this case-by-case evaluation.

Products that are outside the scope of an ETA Guideline may be considered where appropriate through the approved procedure without guidelines according to Art. 9.2 of the CPD.

¹ An ETA Guideline itself is not a technical specification in the sense of the CPD

ETA Guidelines requirements are set out in terms of objectives and of relevant actions to be taken. ETA Guidelines specify values and characteristics. Conformity with these carries the presumption that the requirements set out are satisfied, whenever the state of the art permits such. The ETA Guidelines may indicate alternative possibilities for demonstrating satisfaction of the requirements.

This ETA Guideline incorporates, by dated or undated reference, provisions from other publications. These normative references are cited at the appropriate places in the text and the publications are listed below. For dated references subsequent amendments to, or revisions of these publications, apply to this ETA-Guideline only when incorporated in it by amendment or revision. For undated references, the latest dated revision of the publications referred to applies.

2 Scope

2.1 Scope of Guideline

This Guideline relates to Structural Sealant Glazing Kits (SSGK) for use as facades and roofs, or parts thereof, with glazing at any angle between vertical and 7° above horizontal (see Figures 1, 3 and 4). This part of the Guideline covers the general requirements for assessing kits and structural sealants, and the specific requirements for supported (types I and II) and unsupported (types III and IV) systems (see Figure 1), where the structural seal adhesion surfaces are glass, either uncoated or with an inorganic coating, and anodised aluminium or stainless steel.

This part of the ETAG allows issuing ETAs on structural sealant glazing kits and on structural sealants. The SCC decision presently offers CE marking of the structural sealant as a possibility to the sealant producer, but this is not a requirement. The structural sealant may not be CE marked but assessed in the framework of SSGK. The structural sealant, if it contains its own CE marking, shall only be assessed for its suitability for use in SSGK.

Other parts of the document will cover the specific requirements for the assessment of the use of aluminium with a coating other than anodising, and the use of thermal breaks in SSG framing systems.

When needed, other parts of the Guideline are to be used together with this general document as indicated.

Structural Sealant Glazing Kits

Structural Sealant Glazing Systems use the technique of bonding glazing in order to redistribute loads to the facade structure via a structural sealant and a structural sealant support frame.

These systems are normally marketed as a “kit” of components (ref. EC Guidance Paper C "The treatment of kits and systems under the Construction Products Directive"), giving a designer the choice of components required for a particular facade.

The ETA will indicate details on the components it covers, to be used in accordance with the ETA holder's design rules and installation guide. Typically, some of the components will be manufactured by the ETA holder and some by other manufacturers.

This Guideline covers the performance aspects of a facade making use of the Structural Sealant Glazing System as shown in Figure 4, and allows for the options possible within the kit. The kit components may include the members required for the facade structure, but these are not covered by this Guideline (members indicated by dashes in Figure 4). They, however, will need to be taken into account when dealing with the pre-conditions specified in Chapter 7.

The product description shall include the components necessary to determine the performance as specified below (non-exhaustive list):

- A set of mutually compatible framing members and their assembly technique (corner, T - liaison) and their tightness technique. This set of members serves as the structural sealant support frame
- A set of accessory profiles and accessories (mechanical self-weight support, anchorage of the structural sealant support frame to the frame)
- The generic type of infill element (glass)
- An air and watertightness technique including
 - o The gaskets (material and geometry) and their corner assembling technique (bonding or welding)
 - o A rebate ventilation and drainage technique (section and distance between the drainage and ventilation holes)
 - o Any complementary provisions for tightness such as sealant ropes, etc.
- Ironworks identified by a trademark and a serial reference
- An infill element setting technique including
 - o The blocking of the infill elements in the framework and their setting blocks etc.
 - o The tightness of the infill panel by sealant or gasket (material and geometry)
- Any other components or accessories as relevant

SSGK can be constructed in four different ways. These are described below in Table 1 and depicted in Figure 1.

Devices to reduce danger in the event of bond failure may be required by national regulations.

Table 1 - SSGK types

Type I:	Mechanical transfer of the self-weight of the infill to the sealant support frame and from there to the structure. The structural seal transfers all other actions. Devices are used to reduce danger in the event of a bond failure
Type II:	Mechanical transfer of the self-weight of the infill to the sealant support frame and from there to the structure. The structural seal transfers all other actions, and no devices are used to reduce danger in the event of bond failure.
Type III:	The structural seal transfers all actions including the self-weight of the infill to the sealant support frame, and from there to the structure. Devices are used to reduce danger in the event of a bond failure.
Type IV:	The structural seal transfers all actions, including the self-weight of the infill, to the sealant support frame and from there to the structure. No devices are used to reduce danger in the event of bond failure.

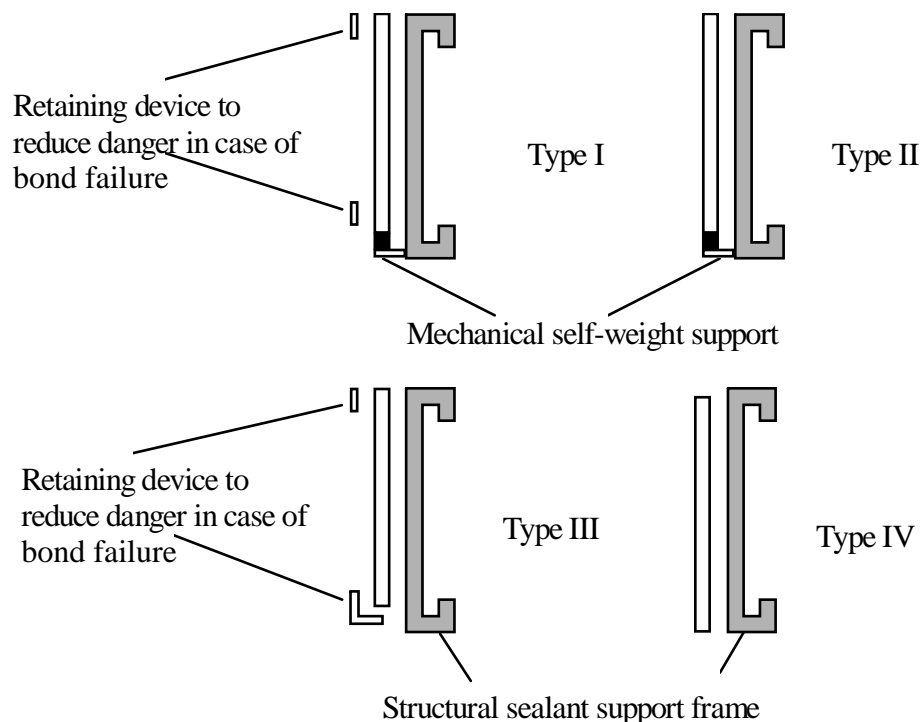

Figure 1 - Schematic examples of the different types of SSGK

Current state of the art necessitates a number of general restrictions:

- The structural bond is to be silicone in the form of a linear bead
- The design may include discontinuities in the structural bond, but no edge may be entirely free; some edges may be mechanically beaded
- The structural sealant is to be factory applied

In due course, further parts of the Guideline may be issued to reduce these restrictions.

It is assumed that system designers will follow normal good practice regarding such matters as glass supply condition (cleanliness, freedom from defects, etc) and application (use of heat-strengthened or laminated glass, etc. as required). These matters are not covered by this Guideline as they are adequately covered by the codes and standards. There are, however, a number of important

requirements that directly affect the design of SSG systems. The following list, though not exhaustive, sets out some of these requirements:

- The machining of glass (for example, when required for fitting glazing safety devices) may only be carried out by and/or in agreement with the glass manufacturer.
- Glass shall be selected to ensure it will safely transmit the wind load to the structural sealant support frame via the structural sealant in accordance with national design codes.
- Structural sealant adhesion on three surfaces is not permissible (see Figure 2). Adhesion to a spacer in an insulating glass unit shall not be considered a structural bond

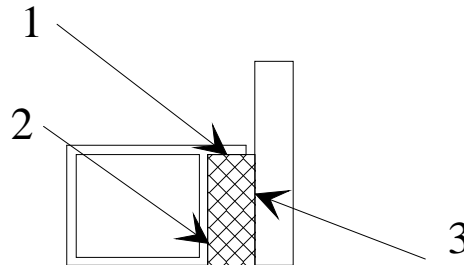

Figure 2 - Structural adhesion on three surfaces - not permissible

- The angle θ shows the range of permissible inclinations above 7° (see Figure 3)

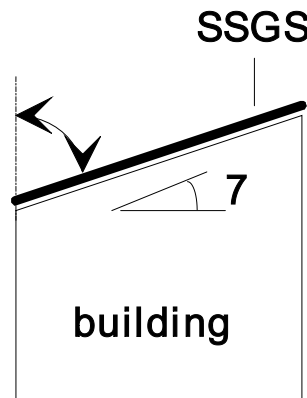

Figure 3 - Permissible inclination θ

- The present specifications do not apply to a composite system in which the interior pane of the IGU is mechanically fastened and the exterior pane is retained by structural sealant
- Types III and IV SSGK are only applicable to single glass units. For insulating glass units or laminated glass, each pane of glass shall be supported (type I or II)

2.1.1 Structural sealant

The structural sealants are to be used in a structural sealant glazing system (SSGK) to bond glazing products to metallic structural seal support frames and/or as the second barrier of the structural hermetic seal in insulating glass units. (See fig. 4)

The Essential Requirements ER2: Safety in case of fire, ER3: Hygiene, health and environment, ER4: Safety in use, ER6: Energy economy and heat retention shall be fulfilled, and failure of the structural bond would cause risk to human life and/or have considerable economic consequences.

The provisions made in this European Technical Approval Guideline are based on the assumed 25-year working life of the SSGK in bonding with a structural function. The assumed working life of a system cannot be taken as a guarantee given by the producer, but is to be used as a means for selecting the appropriate product in relation to the expected economically reasonable working life of the works.

The structural sealants are normally available on the market, independent of the kit, and can be CE marked as a kit component (ref. EC Guidance Paper C "The treatment of kits and systems under the Construction Products Directive").

The ETA will mention the generic and specific (when relevant) types of structural seal adhesion substrates it covers, and will detail the complementary assessment to be done in the framework of the kit ETA when the specific substrate is not mentioned in the ETA for the sealant.

2.2 Use categories

The specification of some SSG kits and the related approach to their assessment necessitates the application of a Use Category in respect of the following aspect of performance:

Use at low temperature

If specified by the manufacturer, kits may be tested at a very low temperature (see 5.1.4.1) to assess their suitability for use in cold regions, e.g. in Nordic countries.

3 Terminology

3.1 Common terminology and abbreviations

3.1.1 Works and products

3.1.1.1 Construction works (and parts of works) (often simply referred to as “works”) (ID1.3.1)

Everything that is constructed or results from construction operations and is fixed to the ground. (This covers both building and civil engineering works, and both structural and non-structural elements).

3.1.1.2 Construction products (often simply referred to as “products”) (ID 1.3.2)

Products that are produced for permanent incorporation in the works, and marketed as such. (The term includes materials, elements, components and prefabricated systems or installations.)

3.1.1.3 Incorporation (of products in works) (ID 1.3.2)

Permanent incorporation of a product in the works means:

- Its removal reduces the performance capabilities of the works, and
- The dismantling or replacement of the product are operations that involve construction activities

3.1.1.4 Intended use (ID 1.3.4)

Role(s) that the product is intended to play in the fulfilment of the Essential Requirements.

3.1.1.5 Execution (ETAG format)

Used in this document to cover all types of incorporation techniques such as installation, assembly, incorporation, etc.

3.1.2 Performance

3.1.2.1 Fitness for intended use (of products) (CPD 2.1)

The products have characteristics such that the works in which they are intended to be incorporated, assembled, applied or installed, can, if properly designed and built, satisfy the Essential Requirements.

(N.B. This definition covers only the intended fitness for intended use as far as relevant to the CPD.)

3.1.2.2 Serviceability (of works)

Ability of the works to fulfil their intended use and in particular the Essential Requirements relevant to this use.

The products shall be suitable for construction works that (as a whole and with respect to their separate parts) are fit for their intended use, subject to normal maintenance, for an economically reasonable working life. The requirements generally concern actions that are foreseeable (CPD Annex I, Preamble).

3.1.2.3 Essential requirements (for works)

Requirements applicable to works that may influence the technical characteristics of a product and that are set out in objectives in the CPD, Annex I (CPD, art. 3.1).

3.1.2.4 Performance (of works, parts of works or products) (ID 1.3.7)

The quantitative expression (value, grade, class or level) of the behaviour of the works, parts of works or of the products, for an action to which it is subject or which it generates under the intended service conditions (works or parts of works) or intended use conditions (products).

3.1.2.5 Actions (on works or parts of the works) (ID 1.3.6)

Service conditions of the works that may affect the compliance of the works with the Essential Requirements of the Directive and which are brought about by agents (mechanical, chemical, biological, thermal or electro-mechanical) acting on the works or parts of the works.

3.1.2.6 Classes (for Essential Requirements and for related product performances) (ID 1.2.1)

A classification of product performance expressed as a range of requirement levels applicable to the works, determined in the IDs or according to the procedure provided for in art. 20.2a of the CPD.

3.1.3 ETAG format

3.1.3.1 Requirements (for works)

Expression and application in more detail and in terms applicable to the scope of the Guideline, of the relevant requirements of the CPD (given concrete form in the IDs and further specified in the mandate), for works or parts of the works, taking into account the durability and serviceability of the works.

3.1.3.2 Methods of verification (for products)

Verification methods used to determine the performance of the products in relation to the requirements for the works (calculations, tests, engineering knowledge, evaluation of site experience, etc.)

3.1.3.3 Specifications (for products)

Transposition of the requirements into precise and measurable (as far as possible and proportional to the significance of the risk) or qualitative terms, related to the products and their intended use.

3.1.4 Working life

3.1.4.1 Working life (of works or parts of the works) (ID 1.3.5(1))

The period of time during which the performance will be maintained at a level compatible with fulfilment of the Essential Requirements.

3.1.4.2 Working life (of products)

Period of time during which the performance of the product is maintained – under the corresponding service conditions – at a level compatible with the intended use conditions.

3.1.4.3 Economically reasonable working life (ID 1.3.5(2))

Working life, which takes into account all relevant aspects such as costs of design, construction and use, costs arising from hindrance of use, risks and consequences of failure of the works during its working life, and cost of insurance covering these risks, planned partial renewal, costs of inspections, maintenance, care and repair, costs of operation and administration, of disposal and environmental aspects.

3.1.4.4 Maintenance (of works) (ID 1.3.3(1))

A set of preventive and other measures that are applied to the works in order to enable the works to fulfil all of their functions during their working life. These measures include cleaning, servicing, repainting, repairing, replacing parts of the works where needed, etc.

3.1.4.5 Normal maintenance (of works) (ID 1.3.3(2))

Maintenance, normally including inspections, which occurs at a time when the cost of the intervention to be made is not disproportionate to the value of the part of the works concerned, with account being taken of consequential costs.

3.1.4.6 Durability (of products)

Ability of the product to contribute to the working life of the works by maintaining their performance, subject to the corresponding service conditions, at a level compatible with the fulfilment of the Essential Requirements by the works.

3.1.5 Conformity

3.1.5.1 Attestation and evaluation of conformity (of products)

Provisions and procedures as laid down in the CPD and fixed according to the Directive, intended to ensure that the specified performance of the product is achieved by the on-going production with an acceptable level of probability.

3.1.5.2 Identification (of a product)

Product characteristics and methods for their verification that allow comparison between a given product and the one described in the technical specification.

3.1.6 Abbreviations

3.1.6.1 Abbreviations concerning the Construction Products Directive

AC: Attestation and Evaluation of Conformity
CEC: Commission of the European Communities
CEN: Comité Européen de Normalisation (European Committee for Standardization)
CPD: Construction Products Directive
EC: European Communities
EFTA: European Free Trade Association
EN: European Standards
FPC: Factory Production Control
ID: Interpretative Documents of the CPD
ISO: International Standardisation Organisation
SCC: Standing Committee for Construction of the EC

3.1.6.2 Abbreviations concerning approval:

EOTA: European Organisation for Technical Approvals
ETA: European Technical Approval
ETAG: European Technical Approval Guideline
TB: EOTA Technical Board
UEAtc: Union Européenne pour l'Agrément technique (European Approval Union).

3.1.6.3 General abbreviations:

IGU: Insulating Glass Unit
SSGK: Structural Sealant Glazing Kits
TC: Technical Committee
WG: Working Group.

3.2 Particular terminology

The terminology is shown in Figure 4 - a vertical section of a supported kit. Drainage is not shown.

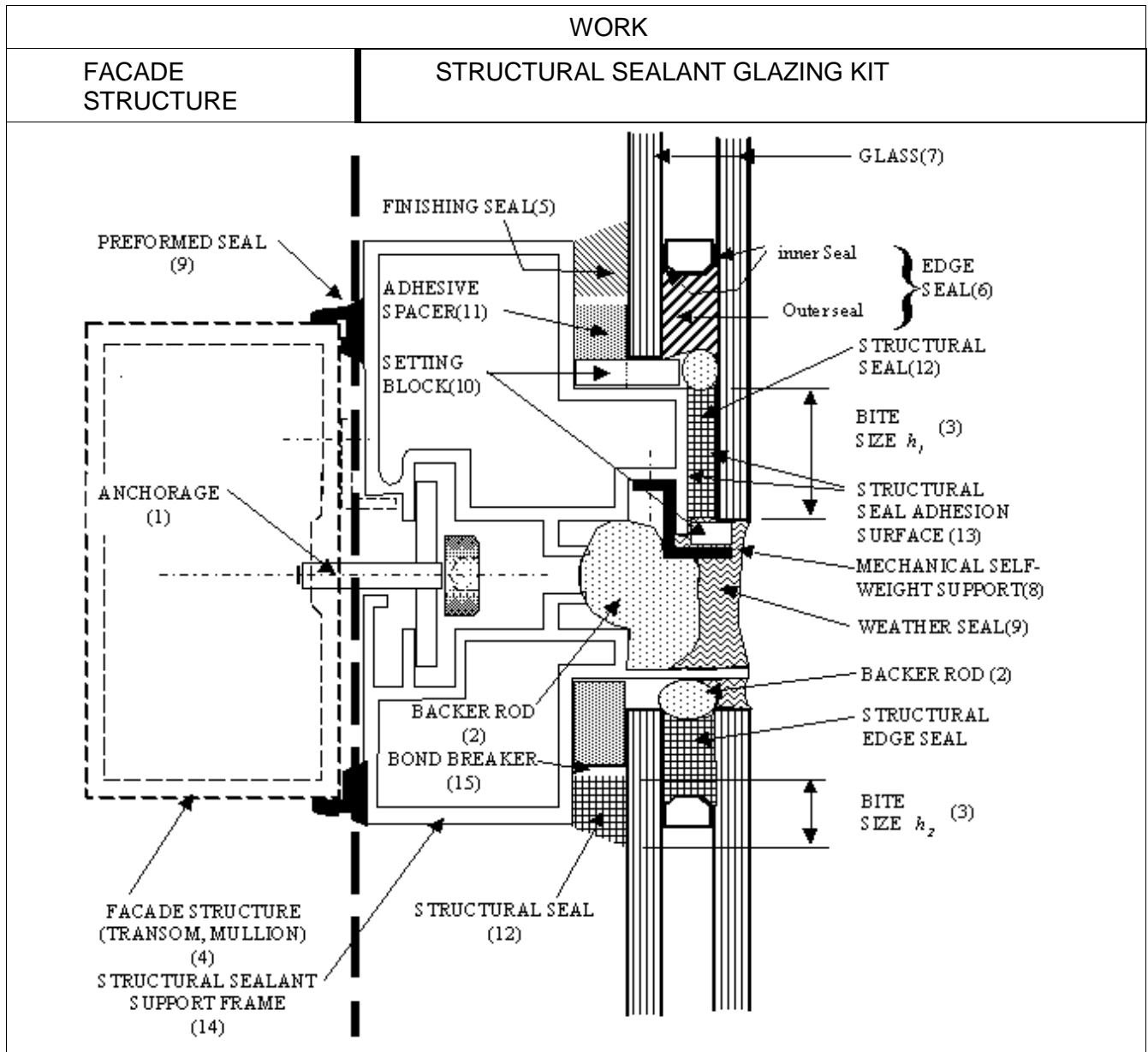

Figure 4 - Structural Sealant Glazing Kit - vertical section (illustration for terminology purposes only)
Numbers correspond to the numbers in Figure 4.

(1) Anchorage

Anchorage of the structural sealant support frame to the facade structure.

(2) Backer rod

Continuous preformed strip limiting the depth of a seal.

(3) Bite

The dimension of the structural seal as measured in the plane of a panel. This term also refers to the same dimension of the hermetic seal of an insulating glass unit.

(4) Facade structure

Members to which the structural sealant support frame are connected and that transmit forces to the building.

(5) Finishing seal

An extruded fillet of elastic sealant material of suitable cross-section, which when cured provides an adequate barrier to air and water, or a pre-formed gasket of cross-section.

(6) Hermetic (edge) seal

A means of providing an airtight seal at the perimeter of an insulating unit. It also resists water or vapour ingress, light and ozone, while remaining compliant to glass displacement due to wind or other loading. In some kit configurations, this seal may have a structural function.

(7) Glass

Glass element consisting of one of the following:

- A single pane (monolithic or laminated)
- An insulating glass unit (IGU) designed for use in SSGK

There can be two IGU types: the non-stepped IGU, where the two panes have the same nominal dimensions, and the stepped IGU, where the two panes of glass have different dimensions (see Figure 4).

See also references for CEN standards on glass.

(8) Mechanical self-weight support

Element positioned under the bottom edge of the glazing that transfers the weight of the glazing to the structural sealant support frame.

(9) Weather seal

Fillet of elastic material or a pre-formed gasket of suitable cross-section, providing an adequate barrier to air and water.

(10) Setting blocks

Load-bearing elements between the mechanical self-weight support and the lower edge of the glass intended to position the glazing unit in the structural sealant support frame.

(11) Adhesive spacer

A continuous preformed strip defining the cross-section of the structural seal and serving to position and align the glass with respect to the structural sealant support frame.

(12) Structural seal

Fillet of a factory-extruded elastic sealant that, when cured, is of sufficient cross-section to adequately transfer the forces between the glass and the structural sealant support frame, and between the panes in an insulating unit.

(13) Structural seal adhesion surface

A continuous surface on the glass or on the structural sealant support frame on which the structural sealant adheres.

(14) Structural sealant support frame

Metal element to which the glass is bonded.

(15) Bond breaker

A non-adhesive interfacial surface that prevents sealant adhesion.

- Complementary terminology (items not shown in Figure 4)

(16) Location block

Resilient material between the structural sealant support frame and a glass edge, other than the bottom edge, to position the glazing unit in the structural sealant support frame.

(17) Mullion

A vertical frame member supporting the vertical edges of the glass element. It may limit the flexibility of the glass element.

(18) Retaining device

A means of retaining the glass to reduce danger in the event of sealant failure.

(19) Transom

A horizontal frame member.

SECTION TWO: GUIDANCE FOR ASSESSING FITNESS FOR USE

4 Requirements (for the works and indication of product-related aspects)

4.0 Preamble

This chapter identifies the performance aspects to be examined in order to satisfy the relevant Essential Requirements, by:

- Expressing in more detail, and in terms applicable to the scope of the Guideline, the relevant Essential Requirements of the CPD (given concrete form in the Interpretative Documents and further specified in the mandate), for works or parts of the works, taking into account the durability and serviceability of the works.
- Applying these to the scope of the ETAG (product/kit and intended use), and indicating the resulting relevant product characteristics and ultimately other aspects.

4.0.1 Economically reasonable working life

This Guideline is written on the assumption that the kit is intended to have a working life of 25 years.

All the product specifications and assessment methods derived from the Essential Requirements for the works and the further requirements for the products shall take account of this assumed working life. The assumed working life of a kit may not be taken as a guarantee given by the producer or the approval body.

All materials used shall exhibit properties or shall be treated to ensure that during the overall working life of the SSGK, under normal conditions of use, there is no risk of major deterioration due to internal or external actions such as those from liquid water, water vapour, solar radiation, temperature, etc.

4.0.2 Initial considerations for the kit

When deciding upon the ways in which the Essential Requirements bear upon an SSGK, it is necessary for the approval body undertaking the technical assessment to obtain full details of the elements included in the kit and those to be covered by the ETA and, having obtained the details, to decide how to apply the verification methods given in Table 3 to the kit in question. The details of the kit would normally be supplied by the organisation (designer/manufacturer) responsible for placing the SSGK on the market.

The submission shall include, as a minimum, the following details:

- (i) The claimed basic levels of performance of the kit and any special claims made, particularly in relation to behaviour in fire, acoustic performance or thermal performance.
- (ii) The structural sealant type, manufacturer and description.
- (iii) The types of glass to be used including the coatings, edge treatment, delivery condition, thickness range, sheet sizes and dimensional tolerances.
- (iv) The type of insulating glass unit (detail whether or not the hermetic (edge) seal has a structural function), if relevant.
- (v) The material and coating type for the sealant support frame.
- (vi) Details, including dimensions and materials specification of ancillary components: spacers, setting blocks, backer rods, weathering components, anchorage.

The type or types of primer to be used to prepare the surfaces, and any necessary conditions required for the application if relevant.

- (viii) The type or types of cleaning product to be used on the complete facade.
- (ix) The calculation method used in determining the required dimensions of the structural sealant in particular applications.

Drawings of the assembled kit, showing details including sealing and drainage arrangements, mechanical fixings of the sealant support frame, the arrangement of retaining devices, details of infill and the arrangements for opening lights (if relevant).

- (xi) For kits allowing for opening lights, the design and supplier details for all hardware used.
- (xii) A copy of the applicant's site installation instructions.

Generally, the declared range of components and materials are used when test samples are prepared. Some concessions are permissible in relation to this requirement, and these are stated in chapter 5.

4.0.3 Relation between the Essential Requirements and the product characteristics

The relationship between the performance of the kit and its elements, the structural sealants, and the Essential Requirements of the Construction Products Directive and the Interpretative Documents is given in Table 2. The table also indicates the relationship between the performance characteristics of the mandate and those used for the assessment of the kit and its components. The Table is to be used in the preparation of a test programme for a kit or components.

4.1 ER1: Mechanical resistance and stability

This Essential Requirement is not relevant to SSGK.

4.2 ER2: Safety in case of fire

The Essential Requirement laid down in Council Directive 89/106/EEC is as follows:

The construction works must be designed and built in such a way that in the event of an outbreak of fire:

- The load bearing capacity of the construction can be assumed for a specific period of time
- The generation and spread of fire and smoke within the works are limited
- The spread of fire to neighbouring construction works is limited
- Occupants can leave the works or be rescued by other means
- The safety of rescue teams is taken into consideration

The following performance aspects are relevant to this Essential Requirement for SSGK:

4.2.1 Reaction to fire

The reaction to fire performance of structural sealant glazing kit or the structural sealant shall be in accordance with laws, regulations and administrative provisions applicable to structural sealant glazing kit or the structural sealant in its intended end-use application. This performance shall be expressed in the form of a classification specified in accordance with EC Decision 2000/147/EC and the classification standard EN 13501 to EN 13501 -1, -2 and -5, respectively.

4.2.2 Resistance to fire

Kit performance with respect to resistance to fire of *curtain walling, the facade or part of these* shall be in accordance with laws, regulations and administrative provisions applicable to *curtain walling or the facade* in its intended end-use application. This performance shall be expressed in the form of a classification specified in accordance with the relevant EC decision and the appropriate CEN classification standard EN 13501 to EN 13501 -1, -2 and -5, respectively.

4.2.3 External fire performance

The external fire performance of *roofs made of SSGK* shall be in accordance with the laws, regulations and administrative provisions applicable to SSGK in their intended end-use application. This performance shall be expressed in the form of a classification specified in accordance with the relevant EC decision and the appropriate CEN classification standard EN 13501 to EN 13501 -1, -2 and -5, respectively.

4.3 ER3: Hygiene, health and environment

The construction works shall be designed and built such that there will be no threat to the hygiene or health of the occupants or neighbours. For facades incorporating SSGK, the following aspects shall be considered:

The relevant requirements are:

- 4.3.1 Air permeability
- 4.3.2. Content and or release of dangerous substances

The product shall be such that, when installed according to the appropriate provisions of the Member States, it allows for the satisfaction of the Essential Requirement 3 of the CPD as expressed by the national provisions of the Member States. Where applicable, the product shall also satisfy ER 3 in respect of the product being allowed to be placed on the market (for example meeting content restrictions)

- 4.3.3 Dampness

4.4 ER4: Safety in use

SSGK facades shall be stable under the combined stresses generated by self-weight, wind load, temperature, moisture, imposed loads, impact, movement of the structure, and snow and ice loads when applicable.

The actions are:

4.4.1 Gravity

Self-weight: Kits of types I and II shall be equipped with a mechanical means of supporting the weight of the glass such that the structural sealant is not required to carry this load. The bearing capacity of this mechanical device shall be determined. In unsupported kits (where there is no mechanical self-weight support), the bearing capacity of the structural seal under long-term shear loading shall be determined.

4.4.2 Effect of wind and snow load

The kit, taking into account (an) appropriate safety factor(s), shall exhibit mechanical resistance to the stresses due to pressure from snow loads and pressure, suction and vibrations caused by the wind.

Any retaining device used shall be designed to retain the glass until repair or replacement can take place should the structural sealant fail.

4.4.3 Effects of building movements

Building movements can result among others from:

- Loading in use (wind, temperature, traffic load ...)
- Differential deformation between members of the building structure
- Differential settlement of foundations
- Vibrations
- Seismic action

Building movements occurring due to any of these causes shall be accommodated by design features in the facade.

It is essential to protect the structural seal from stresses resulting from building movements.

4.4.4 Effect of temperature and barometric pressure

4.4.4.1 Effect of temperature

Extremes of temperatures shall not destroy or irreversibly deform the components of the SSGK.

For practical purposes, surface temperatures of -20°C and 80°C are generally regarded as the limits of temperature range.

For local climatic conditions, temperatures outside these limits can be considered (e.g. in Nordic countries, a temperature of -40°C can be applicable).

For the case in question, in general the thermal movement of the glass and the structural sealant support frame shall be calculated for a temperature range as follows: (for symbols, see Annex 2)

- In summer conditions $UT = T_v - T_c = + 25 \text{ K}$
- In winter conditions $UT = T_v - T_c = - 25 \text{ K}$

However:

- If the sealant support frame is in contact with the external environment around its entire perimeter, it is advisable to make a calculation with $T_v = T_c = 80^\circ\text{C}$, as representative of the most severe conditions.
- In some situations (e.g. special glass, local external conditions, etc.), UT can be modified,

For example:

- Transparent glazing: maximum temperature $T_v=80^\circ\text{C}$
- Opaque glazing: maximum temperature $T_v=100^\circ\text{C}$

The type of glazing shall be suitable and heat accumulation avoided to ensure that excessive temperature variations will not lead to any breakage of the glass.

Barometric pressure

It shall be ensured that the barometric pressure differences between the fabrication site and construction site will not adversely affect the durability of the kit or any of its components.

4.4.5 Table 2 - Relationship between the performance of the kit, its elements and the Essential Requirements

ER	ID #	ID clause for the works	element involved *	performance of the element (with reference to the ID)	characteristics specified in the mandate	corresponding characteristics in the WP	test or evaluation method			
2	2	4.2.3.4 Limitation of the spread of fire and smoke beyond the room of origin	K	4.3.1.3.5.2 Facades, external walls fire resistance performance and fire propagation aspects for external walls including glazing elements	resistance to fire	resistance to fire	Testing determined by the CEN classification standard EN 13501 to EN 13501 -1, -2 and -5, respectively.			
		4.2.4 Limitation of the spread of the fire to neighbouring construction works	K	4.3.1.2.2 Roof exposed to an external fire		"	Idem dito			
		4.2.5 Evacuation of occupants	G	4.3.1.1 Products subject to reaction to fire requirements	reaction to fire	reaction to fire	Idem dito			
3	3	3.3.1.1 Indoor environment - Air quality	K	3.3.1.1.2 - Control of pollutants	water tightness	chemical composition of kit elements	checklist of dangerous substances			
		3.3.1.2 Indoor environment - Dampness	K	3.3.2.2 - Control of dampness		tightness of the kit	air, water test of the kit - moisture presence also ER6 re thermal characteristics			
4	4	3.3.2 Direct impacts	S SF G S+SF+G D K K K G K K	3.3.2.3 Essential characteristics of the products prevention of falling glazed element or piece of glass	bond strength	mechanical resistance and stability	identification of the structural sealant physical and mechanical properties			
		3.3.2.1 Description of the risk - Impact of falling objects forming part of the works upon users						"	"	identification of structural sealant support frame
		"						"	"	identification of glazing mechanical properties of the coupling S + SF + G in the new state and after conditioning and ageing
		"						"	"	mechanical test of devices fatigue test on openable part
		"						"	"	wind resistance test
		"						"	"	creep under long-term shear and cyclic tensile loading
		"						safe breakage	adapted fire resistance test (smouldering curve)	
		"						thermal shock	identification of glass (fragmentation)	
		"						mechanical resistance stability and safe breakage	impact test	
		"						sill height	definition of geometry	
5	5	5.2.3.1 Protection against airborne noise from outside the works	K	4.3.2 Acoustic properties and their expression Acoustic performance of the kit	airborne sound insulation	acoustic insulation	airborne sound insulation			
6	6	6.3.2.2 Space heating, space cooling and humidity control	S	4.3.2 Characteristics of products which may be relevant to the ER The kit and its components shall be designed to limit the amount of energy required for heating and cooling	thermal resistance	thermal insulation	determination of the steady state thermal transmission properties			
		3.2.4 Ventilation						air permeability	tightness of the kit	air, water test of the kit

* K = kit, SF = structural seal support frame, G = glass, S = sealant, D = devices (self-weight support, retaining devices, anchorage of the support frame to the facade structure).

4.4.6 Effect of water

In addition to the normal practice of drainage, the SSGK shall be designed to keep the structural sealant free from stagnant water. The facade shall be designed to prevent water from collecting in the vicinity of the structural bond.

4.4.7 Accidental actions

The design of the structural seal and the specification of the components (e.g. IGU) shall, where necessary, allow for accidental actions such as falling objects, human impact or static human loads.

4.4.8 Sill height

Minimum sill heights are defined in some national regulations. The declared sill height shall comply with the national regulations of the place of use.

4.5 ER5: Protection against noise

The construction works shall be designed and built in such a way that noise transmitted through the SSGK facade from outside is kept to a level that will not threaten the health of occupants and will allow them to sleep, rest and work in satisfactory conditions.

The acoustic performance of the facade depends to an important extent upon the glazing, and when necessary is designed according to the requirements of the intended project. The action of the structural sealant as a sound break may be taken into account.

Where necessary, flanking airborne sound insulation shall be determined for the works in which the kit is to be incorporated.

4.6 ER6: Energy economy and heat retention

The construction works shall be designed and built in such a way that the thermal transmission coefficient of the facade including the SSGK is in accordance with the relevant national regulation for the intended use.

The relevant requirements are:

- 4.6.1 Thermal insulation
- 4.6.2 Air permeability

Note: In some Member States, national regulations may be included in national standards.

4.7 Durability

The action of water, temperature, ultraviolet light and other aspects affecting overall durability have been considered under previous headings.

4.8 Accessories and ancillary products

The accessories normally encountered in an SSGK are the backer rod, setting blocks, gasket weather seal, weather sealant and spacer. This list is not exhaustive.

The fitness for use of these accessories and ancillary products shall be demonstrated for the particular use in the kit, notably:

- Spacer: permeability to water vapour and to structural sealant solvent shall be sufficient to allow cross-linking (curing) at the core of the structural sealant, regardless of whether the latter is a single-component or two-component type. The spacer shall be chemically compatible with its environment and particularly with the structural sealant (test clause 5.1.4.2.5).
- Backer rod: the backer rod shall be chemically compatible with its environment and particularly with the structural sealant (test clause 5.1.4.2.5).
- Setting block: the setting block shall have adequate hardness to support the glazing without damage (Shore D hardness: 70), and be durable and chemically compatible with its

environment (test clause 5.1.4.2.5).

- Weather sealant: the weather sealant is used on the exterior to seal the joint between the glazed elements and as a finishing seal to protect the rebate against cleaning and condensation water. The sealant shall be durable and fit for use in the SSG kit. This can be demonstrated, for example, by compliance with EN ISO 11600.

(+) 1 – EN ISO 11600:2002 Building construction - Jointing products - Classification and requirements for sealants

The weather sealant shall be chemically compatible with its environment and particularly with the structural sealant (test clause 5.1.4.2.5). Low modulus sealants (type G-LM to EN ISO 11600) are advisable for this application.

- Gasket weather seal: the gasket is used on the exterior to seal the joint between the glazed elements and as a finishing seal to protect the rebate against cleaning and condensation water. The gasket shall be durable and fit for use in the SSG kit. This can be demonstrated, for example, by compliance with

(+) 2 - EN 12365:2003 Building hardware - Gasket and weatherstripping for doors, windows, shutters and curtain walling

The weather gasket shall be chemically compatible with its environment and particularly with the structural sealant (test clause 5.1.4.2.5).

- Finishing seal: the finishing seal is used on the interior to seal the joint between the glazed elements and the structural sealant support frames to protect the rebate from surface cleaning water and condensation. The sealant shall be durable and fit for use in the SSG kit. When an extruded sealant is used, a low modulus type is advised. The finishing seal shall be chemically compatible with its environment and particularly with the structural sealant (test clause 5.1.4.2.5).

To assess the fitness for use of these ancillaries, the approval body may make use of information derived from documented sources, such as listed experience, previous approval procedures, references to standards, etc. The specific suitability of the components in the kit can only be demonstrated by compliance with the relevant parts of chapter 5.

4.9 Verifications necessary in case of interchange of components or suppliers

The components and materials of an SSG kit may be specified in one of two ways, by reference to:

- (i) Specific manufactured products, using brand names, part numbers, etc.
- (ii) Generic specifications such as European Standards.

Any kit is likely to include components conforming to both types of specification, taking account of the various components. It is likely that during the lifetime of an ETA, the holder will wish to change the specifications and/or supplier of some components.

Interchanging of a component and/or supplier is to be reported by the approval holder to the approval body issuing the ETA, and to the approved body responsible for Attestation and evaluation of Conformity. It is the responsibility of the approval body to ensure the adequacy of the components, and reference to their specification is to be included in the ETA.

If a component has been specified in terms of a particular manufacturer's product or if a generic specification does not fully cover the fitness of a component for use in an SSGK, any change can only be approved by the approval body issuing the ETA, on completion of such testing as is deemed necessary.

Generally, in such cases, the issuing of a modified ETA will be necessary, with the consequent amendment of the instructions to the approved body.

If a component of an SSG kit is specified generically and the approval body has confirmed the full adequacy of this specification in the ETA, to confirm the fitness of the component for use in the SSG kit, a change of supplier will be acceptable. The approved body checks documentation as deemed necessary by the approval body issuing the ETA. In case of doubt, reference shall be made to the approval body.

5 Methods of verification

5.0 Preamble

Chapter 5 refers to the verification methods used to determine the various performance aspects of the products in relation to the requirements for the works (calculations, tests, engineering knowledge, site experience, etc.).

The tests in this section are designed to identify the structural sealant, to examine the suitability of the structural adhesion surfaces and to verify the performance of the SSGK in relation to the Essential Requirements. There are limitations to the extent to which the latter aspect can be evaluated without knowledge of the design of particular buildings.

Table 3 lists the tests used to verify the performance of the kit components and the kit as a whole in relation to the Essential Requirements. Many of the tests are used to verify more than one aspect, or subdivision, of an Essential Requirement. Hence, it is not possible to list the methods of verification in the same order as the subdivisions of the Essential Requirements.

A number of tests make reference to non-CEN standards. When an appropriate CEN standard becomes available, it may replace the standard currently quoted and the relevant part of the Guideline.

The claimed levels of kit performance shall be declared to the approval body by the organisation (manufacturer or designer) responsible for putting the kit on the market. These claims then will be investigated by the approval body and a judgement made of the kit's adequacy.

If tests are to be conducted on a complete kit, the approval body shall ensure that sufficient tests are undertaken to fully examine the kit details as proposed by the applicant. This will depend on the complexity of the kit and the number of design options it supports. The tests, particularly those under ER4 (Safety in Use), take account of this possible complexity.

The fitness for use of the insulating glass units (IGU), whether or not the hermetic seal has a structural function, shall be demonstrated in accordance with

(+) 3 - EN 1279 Insulating glass units - Part 1: Generalities and dimensional tolerances.

The sealant used as the second barrier of the IGU shall be UV-resistant and chemically compatible with its environment (test clause 5.1.4.2.5). When this second barrier has a structural function, the sealant used is considered a structural sealant, and shall meet all the relevant requirements of Chapter 5 of this Guideline. Normally, the minimum thickness of the outer seal of a structural hermetic seal is 6 mm. All the test methods given relate to supported kits with the exception of the long-term creep test, which is an additional test relevant only to unsupported kits.

5.1 Verification methods related to the Essential Requirements

5.1.1 ER1: Mechanical resistance and stability

This requirement is not relevant to an SSGK (see ER4: Safety in Use).

5.1.2 ER2: Safety in case of fire

5.1.2.1 Reaction to fire

5.1.2.1.1 In the intended end-use conditions

Except where the reaction to fire performance of the SSGK may be known in accordance with other harmonised technical specifications, the SSGK and its components shall be tested, using the test methods relevant to the corresponding reaction to fire class, in order to be classified according to EN 13501-1.

(+) 4 EN 13501-1:2011 - Fire classification of construction products and building elements Part 1: Classification using data from reaction to fire tests

If all the components of the kit are class A1 without testing according to Decision 96/603/EEC as amended, the whole kit may be classified Class A1 without testing. If one or more of the components is classified according to a CWFT Decision, the whole kit may be classified into the lowest class of any component.

The potential contribution of a product to a fire depends not only on its intrinsic properties and the nature of the thermal attack, but also to a large extent on its end-use situation when incorporated in the works. Therefore, tests shall be conducted to simulate its end-use situation.

The reaction to fire classification and relevant testing shall be given for the entire kit.

For the time being, performing assessments according to the reaction to fire tests are judged sufficient in some countries for determining the SSGK's behaviour in fire; in Member States where regulatory requirements demand full-scale facade testing, such testing shall be performed according to national provisions (no European method currently existing). Such testing does not form part of the ETA assessment.

5.1.2.1.2 Fire from rear side

Asymmetrically composed SSGK elements may have to be tested and classified for fire from the rear side according to the provisions of EN 13501-1:2007. When tested in the SBI test rig (EN 13823), the test shall involve a free-hanging arrangement with the flame impingement on the rear side in accordance with EN 13823 (test arrangement without open joints between the SSGK elements on A1 or A2 substrate, so that the distance between the substrate and the SSGK elements amounts to at least 80 mm).

(+) 5 EN 13823:2010 - Reaction to fire tests for building products. Building products excluding floorings exposed to the thermal attack by a single burning item

5.1.2.2 Fire resistance

The part of the works or assembled system in which the SSGK is intended to be incorporated shall be tested, using the test method relevant to the corresponding fire resistance class, in order to be classified according to EN 13501-2. Tests shall be conducted in accordance with EN 1364-3- or -4.

(+) 6 EN 13501-2:2007 - Fire classification of construction products and building elements Part 2: Classification using data from fire resistance tests, excluding ventilation services

(+) 7 EN 1364-3:2006 - Fire resistance tests for non-loadbearing elements. Curtain walling. Full configuration (complete assembly)

(+) 8 EN 1364-4:2007 - Fire resistance tests for non-loadbearing elements. Curtain walling. Part configuration

5.1.2.3 External fire performance

The assembled SSGK, intended to be used as roofs or parts thereof, shall be tested in accordance with the appropriate test method in TS 1187:2012 for the corresponding external performance roof class for the Member State concerned, in order to be classified according to EN 13501-5.

(+) 9 TS 1187: 2012 - Test methods for external fire exposure to roofs

5.1.2.4 Partial collapse in case of fire

See clause 5.1.4.10

Table 3 - Verification of performance

Performance	Reference (see Annex 3)	term (1)	element involved (2)
5.1.1 Mechanical resistance and stability	-		N/A
5.1.2 Safety in case of fire			
5.1.2.1 Reaction to fire	EN 13501-1		K
5.1.2.2 Resistance to fire	EN 13501-2		
5.1.2.3 External fire performance	EN 13501-5		
5.1.2.4 Partial collapse in case of fire	EN 13501-2		
5.1.3 Hygiene, health and the environment			
5.1.3.1 Air/water performance of SSG elements (curtain walling) (Window)	EN 12153 / EN 1026 EN 12155 / EN 1027		K
5.1.3.2 Air quality and dangerous substances	Check EU + national reg. (e.g. EU database)		
5.1.3.3 Dampness			
5.1.4 Safety in use			
5.1.4.1 Initial Mechanical Strength			
5.1.4.1.1 Tension rupture and stiffness	EN 28-339	ST	S, G, SF
5.1.4.1.2 Shear rupture	EN 28-339	ST	S, G, SF
5.1.4.2 Residual mechanical strength after artificial ageing			
5.1.4.2.1 Immersion in water at high temperature	(4)	LT	S, G, SF
5.1.4.2.2 Humidity and NaCl	ISO 9227	ST	S, G, SF
5.1.4.2.3 Humidity and SO ₂	ISO 3231	ST	S, G, SF
5.1.4.2.4 Facade cleaning products	UEAtc SSGK	ST	S, G, SF
5.1.4.2.5 Effects of materials in contact	-	LT	K
5.1.4.3 Mechanical devices			
5.1.4.3.1 Test of the mechanical self-weight support	-	ST	D
5.1.4.3.2 Test of the anchorage of the sealant support frame to the facade structure	-	ST	D
5.1.4.3.3 Test of retaining devices	-	ST	D
5.1.4.4 Tests of openable parts	EN 1191	-	K
5.1.4.5 Impact tests	EN 13049 - EN 14019	-	S
5.1.4.6 Structural Sealant			
5.1.4.6.1 Gas inclusion	UEAtc SSGK	LT	S
5.1.4.6.2 Elastic recovery	EN 27389	LT	S
5.1.4.6.3 Shrinkage	ISO 10563	ST	S
5.1.4.6.4 Resistance to tearing	UEAtc SSGK	ST	S
5.1.4.6.5 Mechanical fatigue	UEAtc SSGK	LT	S
5.1.4.6.6 UV resistance	EN ISO 527	ST	S
5.1.4.6.7 Elastic modulus	EN ISO 527-3	LT	S
Creep under long term shear and cyclic tensile loading	-	LT	S
5.1.4.7 Method of calculating seal dimensions	-	-	K
5.1.4.8 Sill height	-	-	K
Wind resistance test (Curtain walling / window)	EN 12179 / EN 12211	ST	K
5.1.5 Protection against noise	EN ISO 140-3	ST	K
5.1.6 Energy economy and heat retention			
5.1.6.1 Thermal insulation	EN 12412-2 - EN ISO 10077-2	ST	K
5.1.6.2 Air permeability (Curtain walling / window)	EN 12153 / EN 12207	ST	K
5.1.7 Durability aspects	-	-	-
5.2 Verification methods related to the identification of the products			
5.2.1 Structural sealant			
5.2.1.1 Specific mass	ISO 1183-1	ST	S
5.2.1.2 Hardness	ISO 868	ST	S
5.2.1.3 Thermogravimetric analysis	ISO 7111	ST	S
5.2.1.4 Colour	ISO 4660/ISO 7724-1 to -3	ST	S
5.2.2 Anodised aluminium structural adhesion surface			
5.2.2.1 Aluminium alloy	EN 573-3	-	-
5.2.2.2 Characteristics of the anodising			
5.2.2.2.1 Measuring thickness	EN ISO 2360/ISO1463/EN 12373-2-3	ST	SF
5.2.2.2.2 Sealing test	EN 12373-4-5-6	ST	SF
5.2.2.3 Description of the process			
5.2.2.3.1 Scouring	-	-	SF
5.2.2.3.2 Anodising	-	-	SF
5.2.2.3.3 Sealing the anodised layer	-	-	SF
5.2.3 Glass and coated glass	EN 1096-1, -2, -4 and ETAG 002	-	G
5.2.4 Stainless steel structural adhesion surface	EN 10088-1 to 3	-	SF

(1) ST : short-term or initial state, LT : long-term or aged state. (2) K = kit, SF = structural sealant support frame, G = glass, S = sealant, D = devices (mechanical self-weight support, retaining devices, anchorage of the support frame to the facade structure)
(+) 10 - UEAtc Guideline: "Technical Guide for the Approval of Structural Sealant Glazing systems"

5.1.3 ER3: Hygiene, health and the environment

5.1.3.1 Performance with respect to air permeability, watertightness, wind resistance

The assessment of air permeability and watertightness may require the application of wind load to the sample as a conditioning process; therefore, the wind load test procedure is included here for convenience. The structural effects of wind loading are relevant to ER4 (Safety in use) and reference to deflection under load is to be included in the ETA.

The purpose of these tests is to determine, by using the components of the defined SSGK, whether it is possible to build a facade fit for purpose with respect to air permeability, watertightness and wind resistance. Exceptionally, kits may be offered for use only where air permeability and watertightness are not claimed (building entrances, covered gangways, etc.). In such cases, tests need not be conducted.

5.1.3.1.1 Test assembly

The test assembly shall be fully representative of the kit. For example, it shall include an opening light where these are supported by the kit and be designed so that at least one of the elements has the largest surface area for which the drainage arrangements are designed. Tests of a number of separate assemblies or modifications to the original assembly may be necessary in order to include all the declared options, such as inside corners, outside corners and areas of non-vertical glazing. If the use of single – or double – glazing is permissible and the weather sealing details vary as a result, these options shall also be tested.

The supporting structure shall be designed by conventional calculation not to exceed the maximum deflection allowable for the kit at the maximum envisaged wind load.

The sample shown in Figure 5 is only an example of the possible configurations.

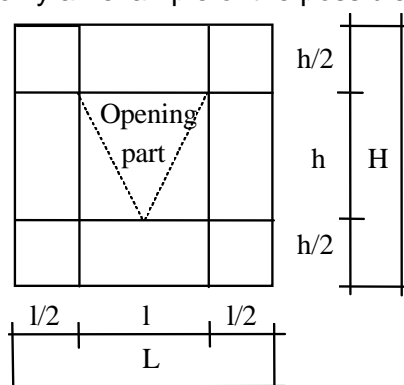

Figure 5 - Example of test assembly

5.1.3.1.2 Air permeability

As a function of the SSGK, which may have the function of a window or curtain walling, this test shall be conducted in accordance with

(+) 11 - EN 12153:2000 — Curtain walling — Air permeability — Test method or

(+) 12 - EN 1026:2000 - Windows and door – Air permeability – Test method

5.1.3.1.3 Watertightness under static pressure

As a function of the SSGK, which may have the function of a window or curtain walling, this test is to be conducted in accordance with

(+) 13 - EN 12155:2000 - Curtain walling — Watertightness — Laboratory test under static pressure

or

(+) 14 - EN 1027:2000- Windows and door – Watertightness – Test method

5.1.3.1.4 Air, wind, water tests – testing sequences

If the windows standards are being used, no testing sequence is established by the EN standards. The testing sequence given in annex 4 shall then be adopted.

If the curtain walling standards are used, the testing sequence for different performance with respect to air, wind and water is given in - § 5.2.EN 13830

(+) 15 - EN 13830:2003 Curtain walling - Product standard

5.1.3.2 Content and/or release of dangerous substances

The applicant shall

- submit the chemical constitution and composition of the *[product and/or constituents of the product]* to the Approval Body which will observe strict rules of confidentiality; or
- submit a written declaration to the Approval Body stating whether or not and in which concentration the *[product and/or constituents of the product]* contains substances which have to be classified as dangerous according to Directive 67/548/EEC and Regulation (EC) No **1272/2008** and listed in the "Indicative list on dangerous substances" of the EGDS - taking into account the installation conditions of the construction product and the release scenarios resulting from there.

The use of recycled materials shall always be indicated, because this could lead to the implementation of further assessment and verification methods.

The information concerning the presence of dangerous substances listed in Council Directive 67/548/EEC and Regulation (EC) No **1272/2008** regulated at European level and listed in the "Indicative list on dangerous substances" of the EGDS and/or of other dangerous substances, shall be circulated as part of the evaluation report by the issuing Approval Body to the other Approval Bodies, under strict conditions of confidentiality.

The product and/or constituents of the product listed in the EOTA TR 034: "General Checklist for ETAGs/CUAPs/ETAs -Content and/or release of dangerous substances in products/kits", which have to be considered will be verified by the given methods taking into account the installation conditions of the construction product and the release scenarios resulting from there. Regulations related to placing the product on the market may also need to be taken into account.

Regarding the release scenarios referred to in the EOTA TR 034, the following use categories have to be considered:

- Category S/W1: Product with direct contact to soil-, ground- and surface water
- Category S/W2: Product with no direct contact to but possible impact on soil-, ground- and surface water
- Category S/W3: Product with no contact to and no impact on soil-, ground- and surface water
- Category S/W1 is applicable for products which are in contact with soil or water in a way that dangerous substances could be released directly out of the product.
- Category S/W2 is applicable for products which can be leached by rain (e.g. external claddings) and could release dangerous substances which can have impact on soil and water.
- Category S/W3 is applicable for products which are completely covered with tight products capable of avoiding any kind of migration of dangerous substances to soil or water.

Note: Content restrictions have to be considered in all cases.

5.1.4 ER4: Safety in use

General

To study the combination of the structural sealant with the bonding surfaces, a number of mechanical properties and the effects of potentially degrading agents need to be known. The following tests are used to determine these properties.

Reminder: Unless otherwise specified elsewhere in this Guideline, the tests given in clause 5.1.4 are only intended for silicone sealant and structural seal adhesion surfaces of glass (uncoated or with an inorganic coating), and anodised aluminium or stainless steel.

- Test pieces for mechanical performance

The test pieces are to be assembled by the manufacturer or in accordance with the manufacturer's instructions with the same material specifications used in the kit, i.e. the structural sealant, the glass and the metal substrate as well as the surface preparation products (cleaning product, primer, etc.) and treatment of surface (anodising, glass coating, etc.).

The relevant reference paragraph of this document, the groups of test pieces for tensile testing, those for shear testing and the type of test pieces that need to be used, are given in Table 4.

Table 4 - Type and number of test pieces

Paragraph reference	Tensile test	Shear test	Test pieces illustrated
Initial mechanical stress			
5.1.4.1	group 1, 20 test pieces	group 2, 20 test pieces	Figure 6
Artificial ageing or conditioning			
5.1.4.2.1	group 1, 10 test pieces	-	Figure 6
5.1.4.2.2	group 1, 10 test pieces	-	Figure 6
5.1.4.2.3	group 1, 10 test pieces	-	Figure 6
5.1.4.2.4	group 1, 10 test pieces	-	Figure 6
5.1.4.2.5 a	5 + 2 test pieces or 10 + 2 test pieces		Figure 10
5.1.4.2.5 b	5 test pieces		Figure 11

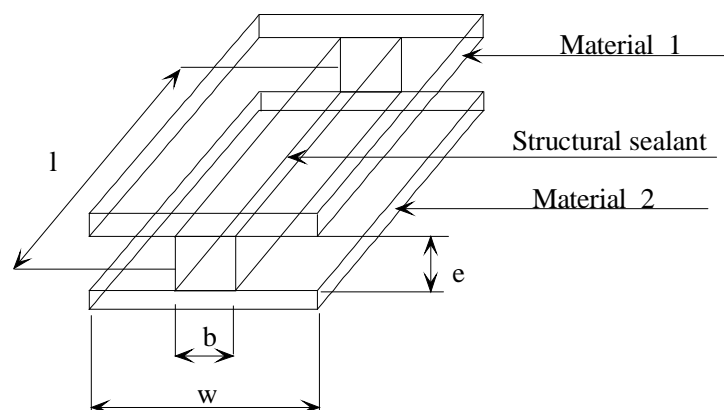

Figure 6 - Dimensions of test pieces

The substrate shall be sufficiently stiff to avoid bending.

For the tests mentioned in ETAG 002 Table 4, the sample described in EN 28339 Figure 2 can be used as well as the one described in ETAG 002 Figure 6.

Table 5 - Dimensions of test pieces

Symbol	Dimensions and tolerances (mm)
b :	12 ± 1
e :	12 ± 1
l :	50 ± 2
w :	40 ± 10

(+) 16 EN 28339:1991 - Building construction. Jointing products. Sealants. Determination of tensile properties

Special care shall be taken to produce symmetrical test pieces.

If the test is conducted on the actual profile of the kit, tension shall be applied without bending the profile.

The clamps of the apparatus for tensile testing shall move in pure axial translation.

All the test samples are conditioned initially for 28 days after manufacture at a temperature of (23 ± 2)°C and at (50 ± 5)% relative humidity. Unless otherwise stated, these shall also be the ambient conditions during testing.

The breaking stress of each sample shall be calculated using each breaking force and the measured dimensions of this sample. These values are then used to determine the mean value of X_{mean} and $R_{u,5}$.

5.1.4.1 Initial mechanical strength

After initial conditioning, the test pieces shall be subjected to tensile tests as shown in Figure 7 and shear tests as shown in Figure 8.

5.1.4.1.1 Tension, rupture

The aim of this test is to evaluate the resistance of the structural sealant to the tensile forces acting on the joints.

After initial conditioning, the test specimens shall be further conditioned for (24 ± 4) hours as follows:

- 5 test specimens conditioned at - 20°C⁽¹⁾
- 10 test specimens conditioned at + 23°C
- test specimens conditioned at + 80°C.

⁽¹⁾ This temperature can be -40°C for European Nordic countries if required by the Applicant (see clause 2.2) and then subjected to tension until failure in accordance with Figure 7.

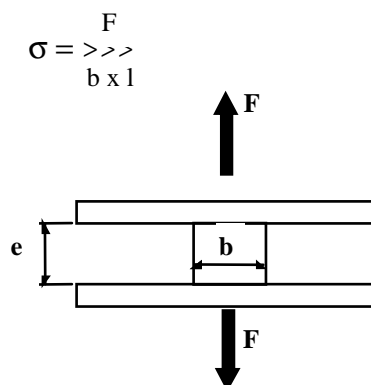

Figure 7 - Sample for tensile test - tension speed: 5 mm/min

Where

- F: tensile force

- : Tensile stress
 - b and l are respectively the width and the length of the sealant section
- From the stress-at-elongation graph recorded, the following shall be noted:
- The type of failure - whether cohesive or adhesive;
 - Stress at elongations of 5, 10, 15, 20 and 25%;
 - The stress and elongation at rupture, only for test specimens conditioned at + 23°C.

5.1.4.1.2 Shear, rupture

The aim of this test is to evaluate the inherent resistance of structural sealants to the shear forces acting on the joints.

After initial conditioning, the test specimens shall be further conditioned for (24 ± 4) hours as follows:

- 5 test specimens conditioned at - 20°C⁽¹⁾
- 10 test specimens conditioned at + 23°C
- 5 test specimens conditioned at + 80°C.

⁽¹⁾ This temperature can be -40°C for European Nordic countries if required by the Applicant (see clause 2.2) and then are subjected to a shear test to rupture in accordance with Figure 8.

The test is conducted at a speed of 5 mm/min.

From the stress-at-elongation graph recorded, the following shall be noted:

- The type of rupture - whether cohesive or adhesive
- Stress at relative displacement to thickness of the substrate (d) of 5, 10, 15, 20 and 25% and at rupture for test specimens conditioned at +23°C.

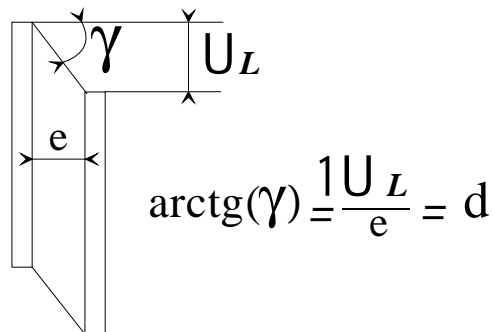

Figure 8.a - Measurement of shear displacement

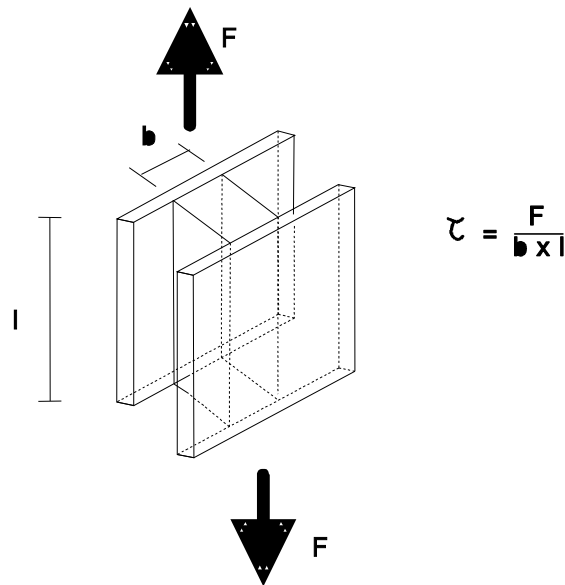

Figure 8.b - Sample for shear test - Shear speed 5 mm/min

5.1.4.2 Residual mechanical strength after artificial ageing

5.1.4.2.1 Immersion in water at high temperature with or without solar radiation (see also clause 5.1.4.6.6)

The aim of this test is to examine the effect of artificial ageing on the residual mechanical strength of the structural sealant. A direct correlation between natural solar ageing and accelerated UV ageing has not been fully established at present.

Materials and equipment

- Supports of glass and metal, for the preparation of test specimens and reference specimens with dimensions as described in Figure 6 and Table 5.
- Spacers for the preparation of the specimens, with dimensions 12 mm x 12 mm x 12.5 mm, with anti-adherent surface.

If spacers are made of material to which the sealant adheres, their surfaces shall be made anti-adherent, e.g. by applying a thin wax coating.

- Anti-adherent substrate, for the preparation of test specimens, e.g. polytetrafluorethylene (PTFE) film or vellum paper, preferably according to the advice of the sealant manufacturer.
- Water container with heating device for immersing the test specimens, capable of maintaining a water temperature of $(45 \pm 1)^\circ\text{C}$, and a constant level of water
- Artificial light source with a spectral distribution characterised as follows:
 - o Type of lamp: Xenon (ISO 4892-2) or equivalent

(+) 17 - ISO 4892-2:1994 - Methods of exposure to laboratory light sources - Part 2 Xenon-arc source

- o Power: $(60 \pm 5) \text{ W/m}^2$ measured at the level of the sample, and between 300 and 400 nm
- o Total energy of the lamp: 500 to 600 watts
- o Black panel thermometer with a blackened absorbing metal plate that approximates the absorption characteristics of a "black body". The plate shall be at least 1 mm thick and of a size to fit the test specimen holders. The temperature of the metal plate is measured by a suitable thermometer or thermocouple with good thermal contact. For measuring the test temperature, it shall be mounted in a test specimen holder with the blackened side of the metal plate facing the artificial light source.

- Readings shall only be taken after sufficient time has elapsed for the temperature to become steady. The temperature shall be controlled by adjusting the air exchange rate.
 - Note – Temperature control may be achieved by means of a thermostat, the sensor of which is placed in the climate chamber.
- Test machine with recording device, capable of extending the test specimens at a rate of 5 to 6 mm/min.

Test procedure

The test specimen shall be stored for 21 days in demineralised water (resistivity 1 to 10 MΩ) of $(45 \pm 1)^\circ\text{C}$

For glass substrates, the test procedure combines immersion in water at high temperature with solar radiation.

(see Figure 6, with material 1 a glass product and material 2 a metallic product)

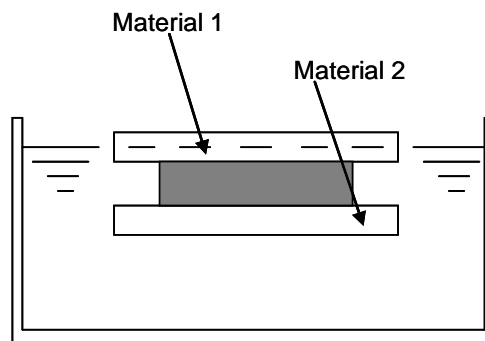

Figure 8.c - Position of samples with glass substrate

For metallic substrates, the test procedure involves full immersion in water at high temperature without solar radiation.

(see Figure 6, with material 1 a metallic product and material 2 a metallic product)

The test pieces are fully immersed (at least 20 mm under water level) in demineralised (resistivity 1 to 10 MΩ) hot water, temperature $(45 \pm 1)^\circ\text{C}$.

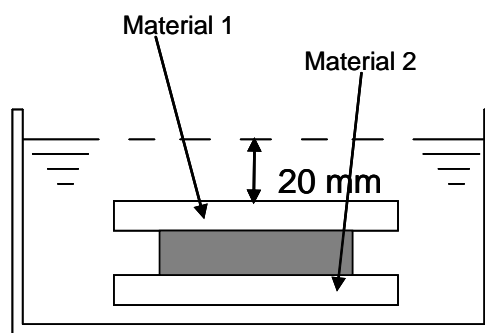

Figure 8.d - Position of samples with metallic substrates

For both substrate combinations, the procedure is as follows:

After 21 days ((504 ± 4) hours) of conditioning, five test pieces are to be removed from the chamber and conditioned for 24 ± 4 hours at a temperature of $(23 \pm 3)^\circ\text{C}$ and $(50 \pm 5)\%$ relative humidity.

The test pieces are then to be subjected to a tensile test in accordance with clause 5.1.4.1.1.

After a further 21 days ((504 ± 4) hours), the five remaining test samples are to be removed from the chamber and subjected to the same tensile test after the same conditioning.

The test results shall include:

- The date and time the test started
- The temperature, relative humidity and period of initial conditioning

During immersion in water:

- A record of the water temperature
- A record of the temperature at the interface of the control samples
- Water conductance values, noting the date and time of measurement.

After removal from the water:

- The dates and times the samples were removed
- A record of the temperature, relative humidity and conditioning period after immersion in water
- The date, time, temperature and relative humidity during the tensile test
- The stress/strain curve

5.1.4.2.2 Humidity and NaCl atmosphere

The conditioning shall be carried out in accordance with ISO 9227 - atmosphere NSS maintained for 480 hours for uncoated glass, glass coated on face 4 (see Figure 9) and other substrates, and for 240 hours for glass coated on faces 2 and 3.

(+) 18 - ISO 9227:1990 - Corrosion test in artificial atmosphere - Salt spray test

The test pieces are placed on PVC trays. The test pieces are to be rotated every 24 hours to expose each longitudinal cut edge in turn.

After conditioning, the test pieces shall be conditioned for a further (24 ± 4) hours at a temperature of $(23 \pm 2)^\circ\text{C}$ and $(50 \pm 5)\%$ relative humidity. They shall then to be subjected to tensile tests in accordance with clause 5.1.4.1.

5.1.4.2.3 Humidity and SO₂ atmosphere

The 10 test pieces shall be conditioned in accordance with ISO 3231.

(+) 19 - ISO 3231:1993 - Determination of resistance to humid atmospheres containing sulphur dioxide

Corrosion test in artificial atmosphere - Salt spray test

- Atmosphere 0.20 litres of SO₂
- 20 cycles for uncoated glass, glass coated on face 4 (see Figure 9) and other supports
- 10 cycles for glass coated on faces 2 and 3.

After conditioning, the test pieces shall be removed from the chamber and further conditioned for (24 ± 4) hours at a temperature of $(23 \pm 2)^\circ\text{C}$ and $(50 \pm 5)\%$ relative humidity.

Then they shall be subjected to tensile tests in accordance with clause 5.1.4.1.1.

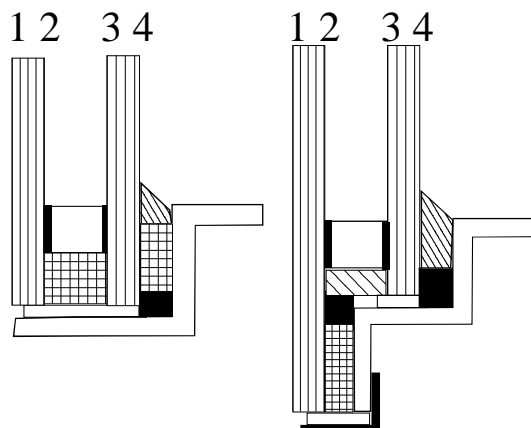

Figure 9 - Numbering of insulating unit faces

5.1.4.2.4 Facade cleaning products

The aim of this test is to assess the effect of cleaning products on the structural bond.

The test pieces shall be immersed for 21 days in the cleaning product(s) (as used in practice) and stored at a temperature of $(45 \pm 2)^\circ\text{C}$. The products shall be those recommended by the facade supplier.

After conditioning, the test pieces shall be removed from the cleaning products and further conditioned for (24 ± 4) hours at a temperature of $(23 \pm 2)^\circ\text{C}$ and $(50 \pm 5)\%$ relative humidity. They shall then to be subjected to tensile tests in accordance with clause 5.1.4.1.1

5.1.4.2.5 Effects of materials in contact

The stability of an SSGK can be affected by incompatibility between the structural sealant and other materials, which may be indicated by discoloration of one of the materials. The following test is designed to investigate this interaction.

It is vital for the test pieces to be prepared with all the material specifications used in the kit, such as structural sealant, weather sealant, spacer materials, aluminium and glazing, as well as manufacturing materials, such as preparatory and cleaning products.

Two test methods are proposed to verify compatibility. It is for the approval body to decide the most appropriate, taking into consideration the risk of UV exposure in service. It may be necessary in some cases to conduct both tests.

a) Method without UV

Seven test pieces shall be produced as shown in Figure 10 and conditioned at a temperature of $(60 \pm 2)^\circ\text{C}$ and $(95 \pm 5)\%$ relative humidity, five for 28 days and the remaining two for 56 days.

Special care shall be taken to produce symmetrical test pieces. The sequence of operations when producing the samples shall reproduce that used in practice.

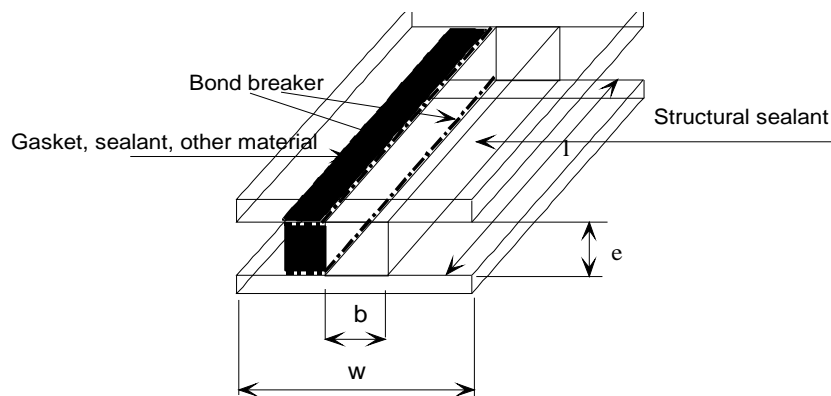

Figure 10 - Typical sample for compatibility test

The samples shall be tested as follows:

Mechanical strength : Five test pieces shall be subjected to the tensile test in accordance with clause 5.1.4.1.1 after 28 days conditioning. The material to be tested for compatibility should be removed before the tensile test so that the results relate only to the bond between the structural sealant and glass and to the structural sealant itself.

If the two materials in the samples cannot be separated without damage, it will be necessary to take five additional samples and test these, as controls, with the secondary material in place and without conditioning.

- Effect on colour : Two test pieces shall be examined for discoloration every 14 days throughout the 56-day conditioning period

b) Method with UV

Test procedure

Five test pieces shall be made as shown Figure 11.

Products 2 and 3 are sealants with which compatibility with product no. 1 is being checked. It may be necessary in some cases to conduct this test with a pale colour sealant specially supplied for this purpose, in order to ensure that any migration is visible. The pale colour sealant shall have the same curing kit as the product normally used.

After 1 to 3 days of curing of the various products, the test pieces are submitted to irradiation using a UV lamp.

- Type of lamp: Xenon (ISO 4892-2) or equivalent
- Power: $(60 \pm 5) \text{ W/m}^2$ measured at the level of the sample, and between 300 and 400 nm
- Temperature: $(60 \pm 2)^\circ\text{C}$
- Duration: (504 ± 4) hours

If adhesion has occurred between products no. 1 and 2, or 1 and 3, a clean incision shall be made to separate them.

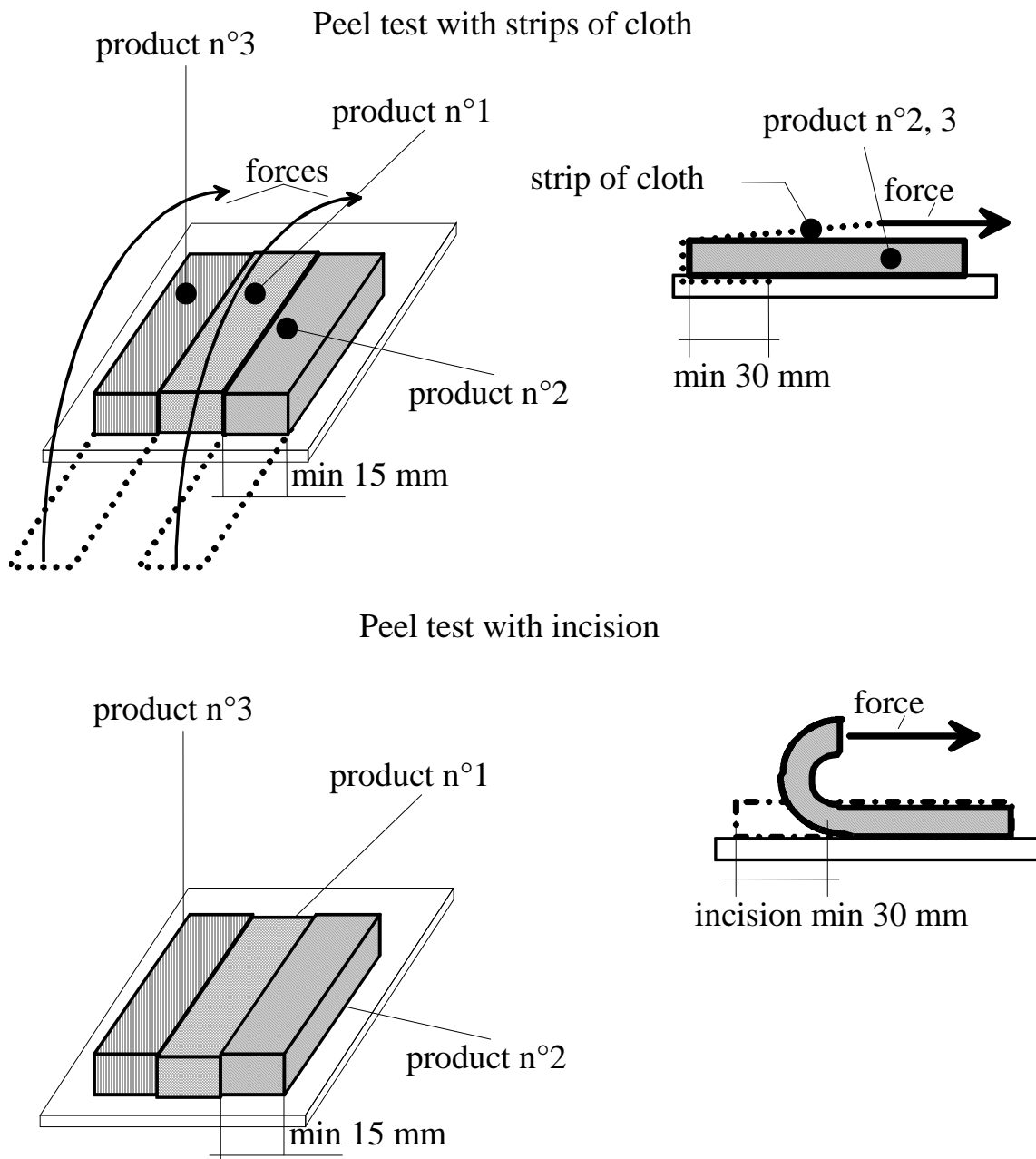

Figure 11 - Peel test - alternatives

Peel test with strips of cloth:

The samples are placed in a tensile test machine and the embedded cloth is peeled back at 180° to the substrate.

Peel test with incisions:

Clean incisions are made at the interface of the substrate and products no. 2 and 3.

The sealant beads are manually peeled back at 180° to the substrate.

Any signs of staining in the pale coloured sealant are noted.

5.1.4.3 Mechanical devices

5.1.4.3.1 Test of the mechanical self-weight support

Normally, the structural adequacy of such supports is assessed using conventional calculations based upon the strength of the materials, and testing will not be required. If the design incorporates novel features, the following test can be used.

Remark: the supporting devices shall not cause any damage to the glass.

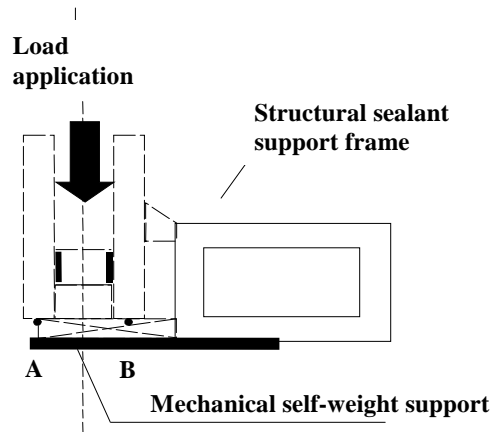

Figure 12 - Test of mechanical self-weight support

The test piece comprises a mechanical self-weight support connected to the structural sealant support frame. The test piece shall reproduce the shape and the usage in the SSGK.

A vertical force simulating the self-weight of the glass is applied at the theoretical centre of gravity of the insulating unit by a means that guarantees that the line of action is vertical.

When loaded, the displacement of the mechanical self-weight support is measured at points A and B (see Figure 12).

5.1.4.3.2 Test of the anchorage of the sealant support frame to the facade structure

Normally, these fixings may be assessed by conventional calculation. If the design precludes this, one of the following tests may be used.

Definitions applicable to both methods:

- F_{des} = design resistance
- γ = safety factor
- $F_{u,5}$ = the characteristic force giving 75% confidence that 95% of the test results will be higher than this value
- F_{mean} = the mean breaking force
- $\tau_{\alpha\beta}$ = eccentricity of 5% with 75% confidence
- s = the standard deviation of the series under consideration
- $P_{br,n}$ = breaking pressure, initial state
- $P_{br,c}$ = breaking pressure, after ageing test
- γ_G = dead load partial factor

a) Method I

The test apparatus shall accurately reproduce the manner in which the fixing is loaded.

- For metallic anchorages, or when $\tau = 3$ is required by the applicant, only a static test shall be conducted.

Static test:

Five anchorages shall be submitted to tension until breaking, using a tension speed of 1 mm / minute

The characteristic static breaking force $F_{u,5}$ value shall be calculated using the formula:

$$F_{u,5} = F_{\text{mean}} - \tau_{\alpha\beta} \cdot s \quad \text{where } \tau_{\alpha\beta} = 2,46 \text{ (see Table 7 section 6)}$$

$$F_{\text{des}} = F_{u,5} / \gamma$$

- For other anchorages, or when $2 \leq \gamma \leq 3$ is required by the applicant, a static and dynamic test shall be conducted.

Static test:

See above static test for metallic anchorage with $\gamma = 3$

Dynamic test:

Five anchorages shall be subjected to repetitive tensile loads with the cycle described in Figure 16, as follows:

- 100 times from $0.1 \times F_{\text{des}}$ to F_{des}
- 250 times from $0.1 \times F_{\text{des}}$ to $0.8 \times F_{\text{des}}$
- 5000 times from $0.1 \times F_{\text{des}}$ to $0.6 \times F_{\text{des}}$.

(for a description of the cycle, see Figure 16 - Stress cycle for fatigue test).

b) Method II

When it is impossible to separately test the anchorage of the sealant support frame to the facade structure, the anchorage can be tested on a glazed test assembly as shown in Figure 13.

When the anchorage is designed to also handle the dead load as well as the wind, the test sample will be submitted to the maximum dead load allowed at each anchorage with a safety factor γ_G of 1.1.

Static pressure to rupture:

One assembly equipped with four anchorages on a pressure test wall shall be submitted to pressure to the point of rupture. The pressure shall always simulate external suction. $P_{br,n}$ is the rupture pressure. The sample is preferably a square.

Dynamic test:

A second sample shall be subjected to fatigue cycles, as follows:

- 20 times from $0.1 \times P_{br,n}$ to $0.75 P_{br,n}$; gust of max. 8 seconds, gust cycle, see Figure 16
- 200 times from $0.1 \times P_{br,n}$ to $0.50 \times P_{br,n}$; gust of max. 8 seconds, gust cycle, see Figure 16
- 200,000 times from $0.1 \times P_{br,n}$ to $0.25 \times P_{br,n}$; gust of 1 second, no particular cycle required
- 1 time from $0.1 \times P_{br,n}$ to $0.9 \times P_{br,n}$; $0.9 \times P_{br,n}$ is the cycle peak value, no particular cycle required

After the dynamic test, the static test to rupture is conducted on the second sample in order to determine $P_{br,c}$

If the criterion of clause 6.1.4.3.2 of table 8 is met, F_{des} is defined as follows:

$$F_{\text{des}} = P_{br,n} \times a^2 / 4 \times \gamma \quad \text{where } \gamma \geq 2 \text{ and 'a' = side of the rig see Figure 13}$$

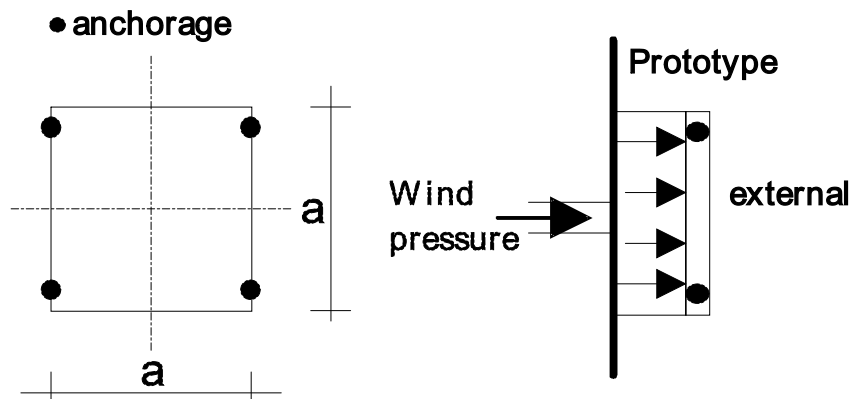

Figure 13 - Test assembly for Method II

5.1.4.3.3 Tests of retaining devices

The performance of the devices shall be assessed from the results of tests or from calculations that allow for the method of attachment to the frame. The variety of designs is such that the approval body will decide upon a relevant approach. The devices themselves shall not cause damage to the glazing.

5.1.4.4 Tests of opening lights

The following tests are to be conducted in order to assess the effect of operation on the structural bond:

- Mechanical tests applicable to opening windows:

(+) 20 - EN 14609: Windows – Determination of the resistance to static torsion.

(+) 21 - EN 14608: Windows – Determination of the resistance to racking

- Durability tests: 10,000 cycles of opening and closing the windows in accordance with

(+) 22 - EN 1191 – Windows and doors - Resistance to repeated opening and closing – Test method

To assess the overall fitness for use of the hardware fitted to opening lights, the approval body may make use of information derived from documented sources, such as listed experience, previous approval procedures, and references to standards.

5.1.4.5 Impact tests

The impact resistance of a light facade is governed by its design features; therefore, impact resistance can vary from building to building using the same SSGK.

If required, the impact resistance of the SSGK, being a facade or a window, shall be tested following the procedure described below:

(+) 23 - EN 13049:2003 Window – Soft and heavy body impact – Test method – Safety requirement and classification

(+) 24 - EN 14019 Curtain walling – Impact resistance – Performance requirement

5.1.4.6 Structural sealant - Physical properties

5.1.4.6.1 Gas inclusions

With certain structural sealants, gas bubbles can form at the glass/aluminium structural sealant interfaces; these can affect the performance of the structural sealant.

One test piece (see Figure 14) with a float glass upper face is prepared in accordance with the structural sealant manufacturer's specifications. The structural sealant shall completely fill the space created between the glass and the aluminium, without any air pockets.

The test specimen shall be stored at a temperature of $(23 \pm 2)^\circ\text{C}$ and at a relative humidity of $(50 \pm 5)\%$ for 21 days. The test specimen shall be checked visually every 7 days. Generation of gas bubbles and their rate of growth shall be recorded.

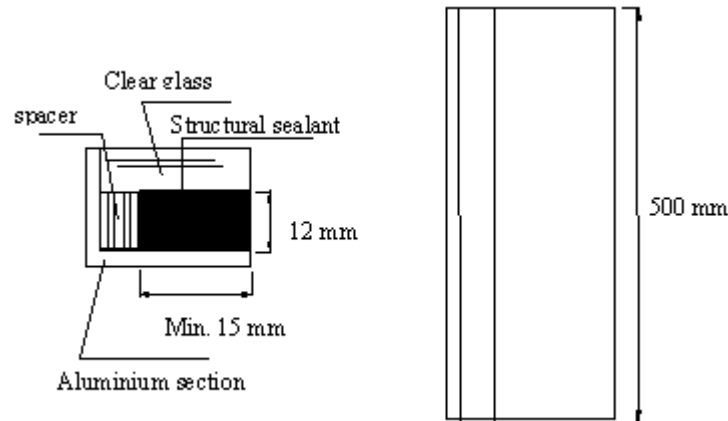

Figure 14 - Sample for gas inclusion test

5.1.4.6.2 Elastic recovery

This test is to be used to evaluate the elastic relaxation behaviour and consequently the relaxation behaviour after long-term loading.

The test shall be conducted on three samples in accordance with EN 27389 standard (ISO 7389), method A with 25% extension.

(+) 25 - EN 27389 / ISO 7389:2002 Building construction - Jointing products - Determination of elastic recovery of sealants

The following shall be noted:

- The initial stress and elongation
- The final stress and elongation
- The elongation after unloading the test pieces.

5.1.4.6.3 Shrinkage

The aim of this test is to evaluate the degree of shrinkage of the structural sealants to limit the initial stresses in the SSG joints. The test shall be conducted on three samples in accordance with ISO 10563.

(+) 26 - ISO 10563:1991 Building construction -- Sealants for joints -- Determination of change in mass and volume

5.1.4.6.4 Resistance to tearing

The aim of this test is to establish the mode of propagation of a cut in the structural sealant.

Five test samples shall be produced and cut at the ends of the structural sealant as shown in Figure 15. The incisions shall be clean, without removal of material. The samples shall then be subjected to a tensile test in accordance with clause 5.1.4.1.1.

The average breaking stress for the reduced measured surface (e.g. $40 \times 12 = 480 \text{ mm}^2$) is calculated.

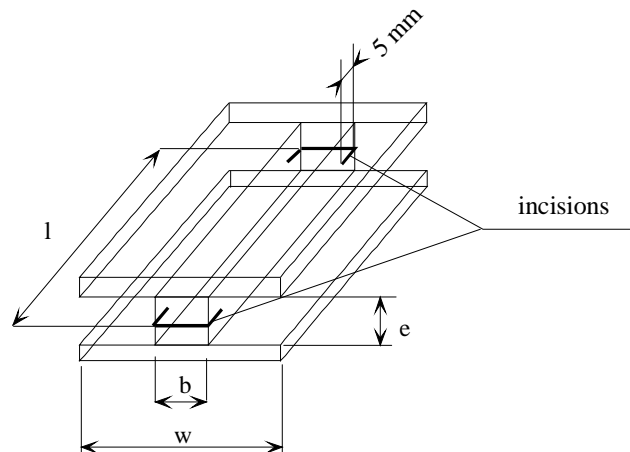

Figure 15 - Sample for incision test

5.1.4.6.5 Mechanical fatigue

The aim of this test is to examine the effect of fatigue stresses on the residual mechanical strength of the sealant bond.

Ten test pieces in accordance with Figure 6 are to be conditioned for 28 days at a temperature of $(23 \pm 2)^\circ\text{C}$ and $(50 \pm 5)\%$ relative humidity.

The test pieces are then to be subjected to repetitive tensile loads with a cycle time of 6 seconds (Figure 16):

- 100 times from $0.1 \sigma_{\text{des}}$ to the design stress σ_{des}
- 250 times from $0.1 \sigma_{\text{des}}$ to $0.8 \times$ the design stress σ_{des}
- 5000 times from $0.1 \sigma_{\text{des}}$ to $0.6 \times$ the design stress σ_{des}

where $\sigma_{\text{des}} = R_{u,5} \gamma_{\text{tot}}$ (see clause 6.1.4.1.1 in Table 8, with $R_{u,5}$ at 23°C)

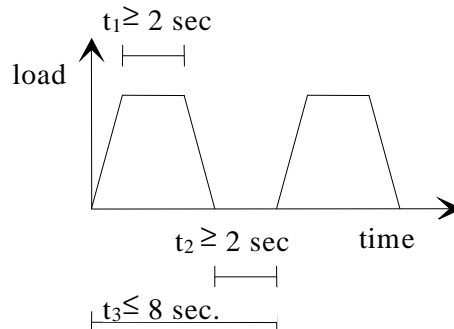

Figure 16 - Stress cycle for fatigue test

with "t₁": duration of the peak load, "t₂": rest time, "t₃": total time of the cycle

After cycling, the structural bonds shall be visually inspected.

The ten test pieces shall then be conditioned for a further (24 ± 4) hours at a temperature of $(23 \pm 2)^\circ\text{C}$ and $(50 \pm 5)\%$ relative humidity, and then subjected to the tensile test in accordance with clause 5.1.4.1.

5.1.4.6.6 UV resistance of the sealant

If necessary, for example to determine the cause of problems occurring during the test detailed in clause 5.1.4.2.1 with UV, the resistance to UV of the structural sealant itself can be assessed using the following method. It should be noted that the number of UV hours applied in this test is

intended to distinguish between products that behave well under such radiation and those that do not. A direct correlation between natural solar ageing and accelerated UV ageing has not been fully established at present.

Ten test pieces are manufactured as type-5 test pieces according to EN ISO 527-3 with all the test pieces having a thickness of $(2,2 \pm 0,2)$ mm (these samples may also be used for the tests prescribed in clause 5.1.4.6.7).

(+) 27 - EN ISO 527-3:1995 Plastics - Determination of tensile properties - Part 3: Test conditions for films and sheets

Five test pieces are then to be subjected to the tensile test according to EN ISO 527-3, at a speed of 5 mm/min.

- Five test pieces are subjected to UV irradiation as follows:
- Type of lamp: Xenon, or equivalent
- Power: (50 ± 5) W/m² measured at the level of the sample, between 300 and 400 nm.
- Duration: (504 ± 4) hours

After irradiation, these five test pieces are to be subjected to the tensile test according to EN ISO 527-3, at a speed of 5 mm/min.

5.1.4.6.7 Elastic modulus of the sealant

The aim of this test is to determine the calculation modulus E_0 to be included in the calculation method given in ANNEX 2.

Five test pieces shall be manufactured as type-5 test pieces according to EN ISO 527-3, with all the test pieces having a thickness of $(2,2 \pm 0,2)$ mm. The test procedure is described in EN ISO 527-3, with a speed of 5 mm/min. The manufacturer shall provide the modulus type to be introduced in the calculation, either tangent or secant to the origin. In the latter case, the boundaries of the curve (deformation, stress (ϵ_1, σ_1) , (ϵ_2, σ_2)) between which the calculation modulus is to be performed shall also be given.

The maximum relative elongation allowed in the calculation shall be that corresponding to the upper boundary used to determine the calculation modulus.

The test report shall contain the graphs (deformation, stress) for each sample.

5.1.4.6.8 Creep under long-term shear and cyclic tensile loading

The aim of this test is to evaluate the creep under long term shear and tensile loading and to determine the creep factor γ_c .

Creep factor - definition

Factor γ_c by which the Γ_{des} shall be divided to obtain a stress Γ_∞ for which no creep is measurable following the criteria of the test described below. γ_c shall always be ≥ 10 :

where

- Γ_{des} : see ANNEX 2,
- Γ_∞ : given by the manufacturer

$$\chi_c = \frac{\Gamma_{des}}{\Gamma_\infty}$$

a) Test specimen

Three test pieces (as illustrated in Figure 17) shall be assembled by the manufacturer or in accordance with its instructions. The support thickness shall be ≥ 6 mm. The sample dimension "e" (see in Figure 17) is to be provided by the sealant manufacturer.

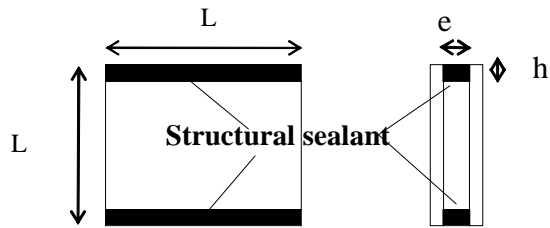

Figure 17 - Sample geometry

b) Test procedure

All the test samples shall be conditioned for 28 days after manufacture at a temperature of $(23 \pm 2)^\circ\text{C}$.

The creep test is performed at room climatic conditions $((21 \pm 1)^\circ\text{C}$ and R.H. $(50 \pm 5)\%$).

Loading (see Figure 18)

- Tensile loading

The three test pieces are subjected to tensile loading M_1 with loading steps of:

$$M_1 = 2 \cdot h \cdot l \cdot P_t$$

with $l = 200 \text{ mm}$,

$$h = 9 \text{ mm}$$

$$M_1 = 3600 \cdot P_t$$

$$P_t = 0,3 \times \sigma_{\text{des. for 91 days}}$$

and $\sigma_{\text{des}} = R_{u,5}/\gamma_{\text{tot}}$ with $R_{u,5}$ set at 23°C see clause 6.1.4.1.2 in Table 8

- Permanent shear loading

Simultaneous with the tensile loading above, the samples shall be loaded with a weight M_2 calculated on the basis of the permanent shear stress provided by the manufacturer Γ_∞ , taking into account a minimum creep factor of 10.

$$M_2 = 2 \cdot h \cdot l \cdot \Gamma_\infty$$

with $h = 9 \text{ mm}$,

$$l = 200 \text{ mm}$$

$$M_2 = 3600 \cdot \Gamma_\infty$$

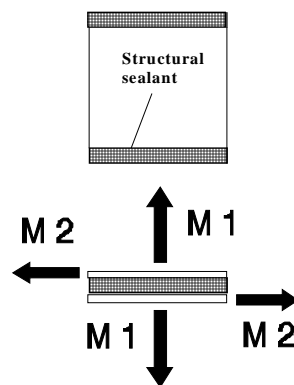

Figure 18 - Loading principle

Test duration

The overall duration of the test shall be 91 days, and the interval time for creep measurements 1 day, 3 days, 7 days, then every 7 days after the loading steps. Measurements shall be made on the loaded sample.

The test results shall include:

- The date and time the test started
- The temperature and relative humidity during the period of initial conditioning
- The creep evolution at 1 day, 3 days, 7 days, then every 7 days after the loading steps
- The deformation after 91 days before unloading
- The residual deformation 24 hours after unloading

5.1.4.7 Method of calculating structural seal dimensions

The normal limits for the SSGK are:

- Minimum thickness of the seal: 4 mm
- $6 \text{ mm} \leq \text{bite of the seal} \leq 20 \text{ mm}$
- Maximum sealant support frame deflection: 1/200 between anchorages, ignoring glass stiffness
- Maximum deflection in the middle of the pane 1/100 (smallest side)

For the detailed methods of calculation, see ANNEX 2.

5.1.4.8 Sill heights

The range of possible sill heights is noted.

5.1.4.9 Wind resistance

As a function of the SSGK, which may have the function of a window or curtain walling, this test shall be conducted in accordance with

(+) 28 - EN 12179:2000 - Curtain walling - Resistance to wind load - Test method or

(+) 29 - EN 12211:2000 - Windows and doors - Resistance to wind load - Test method

and with a test sample as described in 5.1.3.1.1.

5.1.4.10 Partial collapse in case of fire

In order to avoid entire glass panes falling in case of fire, a test should be performed according to EN 13501-2, using the slow heating curve. This is especially relevant when the SSGK is equipped with fire resistant glass.

5.1.5 ER5: Protection against noise - Acoustic insulation

The acoustic insulation of a facade will be governed by the design (size of the glazed elements, presence of opening lights, type and width of glazing, etc.) and the installation (air tightness, etc.).

No standardised calculation method or model has been established at present with which to determine the acoustic insulation of a facade. However, a number of methods of calculation are available based on the fundamental mathematical laws concerned with acoustic insulation, i.e. the laws of mass and frequencies, etc.

These methods generally are complicated, and the result obtained on site is greatly influenced by the care taken in assembly of the facade.

Where specific acoustic properties are claimed, these claims shall be checked by subjecting samples to

(+) 30 - EN ISO 140-3: 1998 Acoustics - Measurement of sound insulation in buildings and of building elements - Part 3: Laboratory measurements of airborne sound insulation of facade elements and facades (ISO 140-3:1998) and by classifying them in accordance with EN ISO 717-1.

5.1.6 ER6: Energy economy and heat retention

5.1.6.1 Thermal insulation

The thermal insulation and/or the susceptibility to condensation of a facade will be governed by the design (size of the glazed elements, the presence of opening lights, type and width of glazing, etc.) and the installation (air tightness, etc.).

Taking into consideration the typical detail shown in Figure 4, it is necessary to allow for a number of materials and their interactions, resulting in a number of different U (thermal transmittance) values.

Thermal insulation and/or susceptibility to condensation (see 5.1.3.3) may be determined by test or calculation, as follows:

a) Aggregate test method

This method involves determining the laboratory steady-state thermal transmission properties of building components for industrial use according to

(+) 31 - EN ISO 12567-1:2000 - Thermal performance of windows and doors - Determination of the thermal transmittance by hot box: method - Part 1: Complete windows and door

(+) 32 EN ISO 12567-2: 2006 - Thermal performance of windows and doors - Determination of thermal transmittance by hot box method - Part 2: Roof windows and other projecting windows

(+) 33 - ISO 8990:1994 - Thermal insulation -- Determination of steady-state thermal transmission properties - Calibrated and guarded hot box (This standard is general and can be used for windows and facade)

(+) 34 - EN 12412-2:2003 - Thermal performance of windows, doors and shutters - Determination of thermal transmittance by hot box method - Part 2: Frames

(+) EN 12412-4: Thermal performance of windows, doors and shutters - Determination of thermal transmittance by hot box method - Part 4: Roller shutter boxes

b) Calculation method

Thermal modelling of an SSGK can be done using thermal conductivity (λ) values determined by the relevant European methods in conjunction with various computer applications. For the results of these programmes to be useable, the programmes shall be at least two-dimensional and cover all the required parameters. The following standard can be taken for evaluation

(+) 35 - EN 10077-2:2003 - Thermal performance of windows, doors and shutters - Calculation of thermal transmission - Part 2 - Numerical method for frame

(+) 36 - EN ISO 10211 - Thermal bridges in building construction - Heat flow surface temperature - Detailed calculations

(+) 37 EN 13947: Thermal performance of curtain walling - Calculation of thermal transmittance-

(+) 38 EN ISO 13789: Thermal performance of buildings - Transmission and ventilation heat transfer coefficients - Calculation method

c) Susceptibility to condensation

Susceptibility to condensation can be assessed in accordance with

(+) 39 - EN ISO 13788:2001 - Hydrothermal performance of building components and building elements - Internal surface temperature to avoid critical surface humidity and interstitial condensation - Calculation methods - Annex D

5.1.6.2 Air permeability

The determination of air permeability is covered under 5.1.3 Hygiene, health and the environment

5.1.7 Durability aspects

There are no specific durability aspects to be tested or assessed that have not been covered under other headings.

5.2 Verification methods related to the identification of the products

5.2.1 Structural sealant

The following determinations of characteristics are valid for all types of silicone structural sealant used in SSG kits.

The identification tests constitute the structural sealant's identity card, comprising at least the graphs and values obtained from the following tests when carried out under well-defined conditions.

5.2.1.1 Specific mass

Determination of the specific mass on three specimens in accordance with

(+) 40 - ISO 1183-1:2004 Plastics -- Methods for determining the density of non-cellular plastics -- Part 1: Immersion method, liquid pycnometer method and titration method

5.2.1.2 Hardness

Measuring shore A hardness in accordance with ISO 868.

(+) 41 - ISO 868:2003 Plastics and ebonite -- Determination of indentation hardness by means of a durometer (Shore hardness)

The measurement shall be carried out on three test pieces after full polymerisation, i.e.:

- After 28 days for single-component silicones
- After 7 days for two-component silicones

5.2.1.3 Thermogravimetric analysis

This identification test seeks to determine the products of the thermal decomposition. Losses are quantified as a function of an even temperature increase.

The test shall be carried out on one specimen in accordance with:

(+) 42 - ISO 7111:1987 - Thermogravimetry of polymers - Temperature scanning method

The results are drawn from the graph of the readings expressed in terms of:

- TG, the percentage of cumulative losses up to 900°C
- DTG, the zones of maximum loss due to volatilisation
- DTA, exothermal or endothermal conversion zones

5.2.1.4 Colour

The colour shall be by reference to ISO 4660 or ISO 7724

(+) 43 - ISO 7724-1:1984 - Paints and varnishes -- Colorimetry -- Part 1: Principles

(+) 44 - ISO 7724-2:1984 - Paints and varnishes -- Colorimetry -- Part 2: Colour measurement

(+) 45 - ISO 7724-3:1984 - Paints and varnishes -- Colorimetry -- Part 3: Calculation of colour differences

(+) 46 - ISO 4660:1999 - Rubber, raw natural - Colour index test

5.2.2 Anodised aluminium structural adhesion surface

5.2.2.1 Aluminium alloys

The specification for the aluminium alloy shall be examined for suitability in the SSGK.

(+) 47 - EN 573-3:2003 - Aluminium and aluminium alloys - Chemical composition and form of wrought product - Part 3: Chemical composition

(+) 48 - EN 515:1993 - Aluminium and aluminium alloys - Wrought product - Temper designation

5.2.2.2 Anodising characteristics

The aluminium structural adhesion surface on which the tests in clause 5.1.4 are to be performed, are identified as follows (see Table 8.6 regarding possible use of the Qualanod mark):

(+) 49 - Specification for the quality sign for anodic oxidation coatings on wrought aluminium for architectural purposes - QUALANOD / EURAS - EWAA / European Aluminium Anodisers Association

5.2.2.2.1 Measuring thickness

The following methods may be used:

Eddy current test method according to

(+) 50 - EN ISO 2360:2003 Non-conductive coatings on non-magnetic electrically conductive basis materials - Measurement of coating thickness - Amplitude-sensitive eddy current method

Split-beam optical method according to

(+) 51 - EN 12373-3 - Aluminium alloy - Anodising - Part 3 - Determination of the thickness of anodic oxidation coating - Non-destructive measurement by split-beam microscope.

Microsection method according to

(+) 52 - ISO 1463:2003 Metallic and oxide coatings - Measurement of coating thickness - Microscopical method.

Gravimetric method according to

(+) 53 - EN 12373-2: 1999 - Aluminium alloy - Anodising - Part 2 - Determination of the mass per unit area (surface density) of anodic oxidation coating - Gravimetric method.

5.2.2.2.2 Sealing tests

The following methods may be used:

Stain test according to

(+) 54 - EN 12373-4 - Aluminium alloy - Anodising - Part 4 - Estimation of the loss of absorptive power of anodic oxidation coating after sealing by a spot test with prior acid treatment.

Immersion test according to

(+) 55 - EN 12373-6 - Aluminium alloy - Anodising - Part 6 - Assessment of the quality of a sealed anodic oxidation coating by measurement of loss of mass after immersion in phosphoric acid/chromic acid solution without prior acid treatment.

Measurement of admittance test at 1000 Hz according to

(+) 56 - EN 12373-5 - Assessment of the quality of a sealed anodic oxidation coating by measurement of admittance.

5.2.2.3 Description of the anodising process

The applicant shall provide the approval body with the following information:

5.2.2.3.1 Scouring

- Composition of the bath
- Aluminium bath immersion time

5.2.2.3.2 Anodic oxidation

- Composition of the bath
- Aluminium bath immersion time
- Bath temperature

5.2.2.3.3 Sealing ⁽¹⁾ of the anodised layer

- Bath composition or reference name
- Aluminium bath immersion time
- Bath temperature

Where cold sealing is proposed, additional proof shall be provided by the manufacturer.

The word "sealing" can give rise to a misunderstanding: it is a post-treatment, after anodising. The equivalent in French is "*colmatage*" and in German "*Verdichtung*"

5.2.3 Glass adhesion surface

5.2.3.1 Identification of glass

The applicable glass and glass products are identifiable by reference to the various European standards.

The type of glass used to create the samples for the adhesion-cohesion tests in chapters 5.1.4.1 and 5.1.4.2 is usually normal float glass. For safety reasons, special types of glass can be required for particular projects. Fragmentation shall be tested according to EN or prEN for the type of glass in question.

Possible extrapolation for adhesion between sealant and glass substrates:

When tests 5.1.4.1 and 5.1.4.2 are performed on non-coated float glass according to EN 572-2, the adherence of the glass-structural sealant can be extrapolated to the type of glass:

(+) 57 - EN 12150-1:2000 - Thermally toughened soda lime silicate safety glass - Part 1: Definition and description

(+) 58 - EN 1863-1:2000 - Heat strengthened soda lime silicate glass - Part 1: Definition and description

The present state of the art does not consider chemically toughened soda lime silicate glass (EN 12337) to be extrapolatable.

5.2.3.2 Glass products

5.2.3.2.1 Insulated glass unit:

If double or multiple-glazing units are to be used, these shall be suitable for use in SSG kits. The hermetic seal shall meet the requirements of the relevant standards; if it is required to act as a structural bond, it shall also prove its adequacy by meeting the requirements of this Guideline.

5.2.3.2.2 Laminated safety glass

Only laminated safety glass as defined in the EN 12543-2 is fit for use in structural glazing. No supplementary test of the adhesion/cohesion between the structural sealant and glass substrate used for laminated glass is required

(+) 59 - EN 12543-2:1999 - Laminated glass and laminated safety glass part 2: Laminated safety glass

The following exceptions apply:

- Fire resistant laminated glass
- Laminated glass with cast-in-place resin interlayer (e.g. acoustic glazing)

which can be assessed in the framework of a European Technical Approval according to Article 9.2 of the CPD.

5.2.3.2.3 Enamelled glass (spandrels): When applying the structural seal to enamelled glass, this enamelled glass substrate shall be considered a particular substrate to be tested as follows:

- Chapter 4 Requirements
 - Chapter 5 Methods of verification
- 5.1.4.1 Initial Mechanical Strength
- 5.1.4.1.1 Tension, rupture
- 5.1.4.2 Residual mechanical strength after artificial ageing
- 5.1.4.2.1 Immersion in water at high temperature with or without solar radiation
- 5.1.4.2.2 Humidity and NaCl atmosphere
- 5.1.4.2.3 Humidity and SO₂ atmosphere
- 5.1.4.2.4 Facade cleaning products

- Chapter 6 Assessing and judging the fitness of products for an intended use

Opacified glass with organic resin: These substrates may not be considered suitable substrates for structural bonding. If the opacified organic layer is applied to an inorganic coating, the opacified layer shall be removed and the subjacent inorganic coating assessed according to clause 5.2.3.3.

5.2.3.3 Coated glass

5.2.3.3.1 Suitable coatings

Suitable coatings are the inorganic coatings classified as A, S and B according to the European standard

(+) 60 - EN 1096-1:1999 - Glass in building - Coated glass - Part 1: Definitions and classification

(+) 61 - EN 1096-2:2001 - 2001 - Glass in building - Coated glass - Part 2: Requirements and test methods for class A, B and S coatings

Additional coatings may be added to an amended ETA when they have been shown to be suitable for use in SSG kits.

Other coatings meeting EN 1096 shall be removed along the structural sealant adhesion surface

5.2.3.3.2 Grouping the coatings in families - Representative coating of the family

If the applicant wishes to assess a large number of coatings, to limit the number of tests, the following conditions apply.

The rules contained in EN 1096-2 Annex F are also valid concerning the grouping of coatings into families based on the validity of durability tests for structural sealant glazing application

The representative coating(s) of the family then is/are the one (those) in which all the interfaces between the stacking layers of the family can be found. The interfaces "glass first layer of the stacking" and "last layer of the coating layer - particular sealant" are considered interfaces to be tested. The representative coating(s) - sealant shall be assessed according to clause 5.2.3.3.3 and the tests results are valid for all coated glass of the family.

5.2.3.3.3 Evaluation of the suitability of the bonding of coatings and their layers

For the product submitted for approval, the manufacturer shall provide a description conforming to EN 1096-1 chap 8.2 "identity card" and EN 1096-4 chap 4.1 regarding the coating layer compositions.

It shall be characterised and evaluated in accordance with chapters 4 and 5 of this ETAG

(+) 62 - EN 1096-1:1999 - Glass in building - Coated glass - Part 4: Evaluation of conformity

For each coating or family of coated glass representatives on a structural sealant adhesion surface, it shall be demonstrated that the bonding is sufficiently strong between glass and coating, between sealant and coating, and between the different layers of the coating. Such a demonstration consists of adhesion tests and assessment according to the following chapters of this Guideline:

- Chapter 4 Requirements
- Chapter 5 Methods of verification

5.1.4.1 Initial Mechanical Strength

5.1.4.1.1 Tension, rupture

5.1.4.2 Residual mechanical strength after artificial ageing

5.1.4.2.1 Immersion in water at high temperature with or without solar radiation

5.1.4.2.2 Humidity and NaCl atmosphere

5.1.4.2.3 Humidity and SO₂ atmosphere

5.1.4.2.4 Facade cleaning products

- Chapter 6 Assessing and judging the fitness of products for an intended use

5.2.3.3.4 Evaluation from existing test reports

When a coating is submitted for an evaluation for suitability, the manufacturer may present existing test reports containing the outcome of testing on coatings, consisting of:

- The bonding between the particular sealant and the particular top layer of the coating
- And/or the bonding between the glass and the particular base layer of the coating
- And/or the interlayer bonding between any two layers of the coating

5.2.3.3.5 Glass substrates for coated glass

When the tests of clause 5.2.3.3.2 are performed on one of the coated glass substrates listed below, the coated glass-structural sealant adherence can be extrapolated to other types of glass on this list:

(+) 63 - EN 572-2 Basic soda lime silicate glass products - Part 2: Float glass

(+) EN 12150-1 Thermally toughened soda lime silicate safety glass - Part 1: Definition and description

(+) EN 1863-1 Heat strengthened soda lime silicate glass - Part 1: Definition and description

5.2.4 Stainless steel adhesion surface

Structural sealant adhesion surfaces in the form of rolled or pressed stainless steel are within the scope of this document, if they can be shown to comply with the following chapters, and that structural sealant bonds made to them form a satisfactory kit when tested in accordance with this document:

(+) 64 - EN 10088-1:1995 - Stainless steels - Part 1: List of stainless steels

(+) 65 - EN 10088-2:1995 - Stainless steels - Part 2: Technical delivery conditions for sheet/plate and strip for general purposes

(+) 66 - EN 10088-3:1995 - Stainless steels - Part 3: Technical delivery conditions for semi-finished products, bars, rods and sections for general purposes

- Chapter 4 Requirements
- Chapter 5 Methods of verification

5.1.4.1 Initial Mechanical Strength

5.1.4.1.1 Tension, rupture

5.1.4.2 Residual mechanical strength after artificial ageing

53

- 5.1.4.2.1 Immersion in water at high temperature with or without solar radiation
- 5.1.4.2.2 Humidity and NaCl atmosphere
- 5.1.4.2.3 Humidity and SO₂ atmosphere
- 5.1.4.2.4 Facade cleaning products
 - Chapter 6 Assessing and judging the fitness of products for an intended use

5.3 Verifications necessary in case of interchange of components or suppliers

In the case of component interchange, it shall be ensured that the new component does not have a negative influence on the performance level or the life of the SSGK.

For components specified as described in 4.9 (i), it shall be proven that the new components have the same characteristics as the ones they replace, and that they have little or no influence on the characteristics of the SSGK. Furthermore, it shall be ensured that the new component is compatible with the other components for the envisaged lifetime. Compatibility tests shall be performed to ensure that the exchanged components do not have a negative influence or effect on the components with which it interacts in the kit. For components specified as described in 4.9 (ii), the origin has no influence on the performance as long as the declared characteristics remain the same.

When interchanging a component specified in terms of 4.9(i), the approval body issuing the ETA will determine the test regime based on its experience, as deemed necessary, and using the table below. If in doubt, the issuing approval body may consult the other European approval bodies.

The following table lists the components likely to be substituted and the tests for their assessment, if necessary. Substitution of more than one component may require deeper analysis, since the overall basis for acceptance of the kit may no longer be valid. The table is not exhaustive and can be adapted to the peculiarities of certain kits.

The tests refer either to tests in this Guideline or to CEN standards.

Table 6 - Component interchange

Component	Test for characteristics	Identification tests
Structural seal	5.1.2 - 5.1.4.1 ;5.1.4.2 ;5.1.4.4 ;5.1.4.6	5.2.1
Mechanical self-weight support	5.1.4.3.1	
Anchorage	5.1.4.3.2	
Safety devices	5.1.4.3.3	
Glass	-	5.2.3.1
Coating for glass	See 5.2.3.3	
Aluminium anodising	5.1.4.1 Initial Mechanical Strength 5.1.4.1.1 Tension, rupture at 23°C 5.1.4.2 Residual mechanical strength after artificial ageing 5.1.4.2.1 Immersion in water at high temperature with or without solar radiation 5.1.4.2.2 Humidity and NaCl atmosphere 5.1.4.2.3 Humidity and SO ₂ atmosphere 5.1.4.2.4 Facade cleaning products	5.2.2
Weather seal	Compatibility test clause 5.1.4.2.5	
Setting block	Compatibility test clause 5.1.4.2.5 and SHORE 70	
Spacer, backer rod	Compatibility test clause 5.1.4.2.5	

6 Assessing and judging the fitness of products for an intended use

6.0 Preamble

Chapter 6 details the performance requirements to be met by Structural Sealant Glazing Kits into precise and measurable (as far as possible and proportional to the importance of the risk) or qualitative terms, related to the products and their intended use, using the verification methods (chapter 5).

Each performance requirement to be met for a given intended use is assessed with respect to classes, use-categories or numerical values. The ETA in general shall indicate either the results of these assessments or state "No performance determined" (for countries/regions/buildings where no applicable requirements are foreseen in laws, regulations and administrative provisions). This statement does not mean that the SSGK performs poorly, but merely that this specific performance property has not been declared.

For results outside the requirements given below, the approval body shall subject these to a deeper analysis based on a larger number of test pieces, repeating any questionable tests or other measurements related to the problem concerned.

6.1 General - test result statistical interpretation

$$R_{u,5} = X_{\text{mean}} - \tau_{\alpha\beta} \cdot s$$

$$\Delta X_{\text{mean}} = X_{\text{mean,c}}/X_{\text{mean,n}}$$

where

- $R_{u,5}$ = the characteristic breaking stress giving 75% confidence that 95% of the test results will be higher than this value.
- X_{mean} = the average breaking stress, either under tension or shear.
- $X_{\text{mean,n}}$ = the average breaking stress, either under tension or shear in the initial state.
- $X_{\text{mean,c}}$ = the average breaking stress, either under tension or shear after conditioning or ageing.
- $\tau_{\alpha\beta}$ = the eccentricity of 5% with 75% confidence (see Table 7)
- s = the standard deviation of the series under consideration

and also

- V_{mean} = mean value
- K_x = stiffness of the sample at x% elongation in the initial state
- $K_{x,c}$ = stiffness of the sample at x% elongation after conditioning
- R_{des} = design resistance
- $F_{u,5}$ = the characteristic force giving 75% confidence that 95% of the test results will be higher than this value
- F_{mean} = the average breaking force

Table 7 - The variable $\tau_{\alpha\beta}$ as a function of the number of test pieces (see ISO 3207)

Number of pieces	5	6	7	8	9	10	15	30	∞
Variable $\tau_{\alpha\beta}$	2.46	2.33	2.25	2.19	2.14	2.10	1.99	1.87	1.64

(+) 67 - ISO 3207:1975 Statistical interpretation of data -- Determination of a statistical tolerance interval -

Type of rupture:

A number of tests prescribe "Rupture \geq 90% cohesive", i.e. at least 90% of the sample ruptures shall be located within the sealant, and a maximum of 10% at the interface between the sealant and the glass or metallic substrate.

Table 8.1 - **ER1 and ER2**

Reference	Verification methods	Clause n°	Treatment of results and requirements - Criteria
6.1.1	ER1: Mechanical resistance and stability - not relevant to SSGK		
6.1.2	ER2: Safety in case of fire		
5.1.2.1	Reaction to fire	6.1.2.1	Classification according to EN 13501-1, 2, 3, 5 as relevant
5.1.2.2	Resistance to fire	6.1.2.2	
5.1.2.3	External fire performance	6.1.2.3	
5.1.2.4	Partial collapse in case of fire	6.1.2.4	

Table 8.2 - ER3

Reference	Verification methods	Clause n°	Treatment of results and requirements - Criteria
6.1.3 ER3: Health, Hygiene and the Environment			
5.1.3.1	Air permeability Watertightness	6.1.3.1	Windows: EN 12207 and EN 12208 - No performance-determined option possible Curtain walling: EN 12152 and EN 12154 - No performance-determined option possible
5.1.3.2	Air quality / Dangerous substances	6.1.3.2	No prolonged moisture condensation may occur out of the drained zone or on the interior face of the facade. Handling see clause 6.2 - no performance-determined option possible.

- (+) 68 - EN 12154:2000 Curtain walling - Watertightness - Performance requirements and classification
- (+) 69 - EN 12152:2000 Curtain walling - Air permeability - Performance requirements and classification
- (+) 70 - EN 12207:2000 Windows and doors - Air permeability - Classification
- (+) 71 - EN 12208:2000 Windows and doors - Watertightness - Classification

Table 8.3 - **ER4**

Reference	Verification methods	Clause n°	Treatment of results and requirements - Criteria
6.1.4 ER4: Safety in Use			
6.1.4.1 Initial Mechanical Strength			
5.1.4.1.1	K _{12,5} Tension: -20°C, 23°C, 80°C	6.1.4.1.1	Value expressing the secant stiffness at 12.5%, K _{12,5} (see Annex 1) $R_{u,5} = X_{\text{mean},n} - \tau_{\text{cfs}} \cdot s$ for test at -20°C, +23°C, +80°C
5.1.4.1.2	Shear: -20°C, 23°C, 80°C	6.1.4.1.2	$R_{u,5} = X_{\text{mean},n} - \tau_{\text{cfs}} \cdot s$ for test at -20°C (or -40°C) +23°C, +80°C <u>For tension and shear:</u> $\Delta X_{\text{mean}} = X_{\text{mean}, -20^\circ\text{C}} / X_{\text{mean}, n, 23^\circ\text{C}} \geq 0.75$ - $\Delta X_{\text{mean}} = X_{\text{mean}, 80^\circ\text{C}} / X_{\text{mean}, n, 23^\circ\text{C}} \geq 0.75$ Rupture $\geq 90\%$ cohesive
6.1.4.2 Residual strength after artificial ageing			
5.1.4.2.1	Immersion in hot water	6.1.4.2.1	The minimum requirement is 1000 hours immersion 1) $\Delta X_{\text{mean}} \geq 0.75$ test at +23°C 2) For the $0 \leq x \% \leq 12.5$ of the deformation/stress curve (see Annex 1), the stiffness shall be as follows: $0.5 \leq K_{x,0} / K_x \leq 1.10$ - Rupture $\geq 90\%$ cohesive
5.1.4.2.2	Humidity and NaCl	6.1.4.2.2	$\Delta X_{\text{mean}} \geq 0.75$ test at +23°C - Rupture $\geq 90\%$ cohesive
5.1.4.2.3	Humidity and SO ₂	6.1.4.2.3	$\Delta X_{\text{mean}} \geq 0.75$ test at +23°C - Rupture $\geq 90\%$ cohesive
5.1.4.2.4	Facade cleaning Products	6.1.4.2.4	$\Delta X_{\text{mean}} \geq 0.75$ test at +23°C - Rupture $\geq 90\%$ cohesive
5.1.4.2.5	Materials in contact	6.1.4.2.5	<i>Method without UV:</i> Neither discoloration or $R_{u,5}$ after conditioning $0.85 R_{u,5}$ initial is permitted - Rupture: 90% cohesive <i>Method with UV:</i> After exposure, compatibility is determined by observation for discoloration with normal corrected vision Peel test requirement: no adhesion ruptures permitted during the peel test
6.1.4.3 Retaining Devices			
5.1.4.3.1	Mechanical self-weight support	6.1.4.3.1	The load is noted at which a maximum deflection of 0.5 mm is produced between A and B.
5.1.4.3.2	Anchorage	6.1.4.3.2	<i>Method I:</i> Calculated value: Static: $F_{u,5 \text{ static}} = F_{\text{mean}} - \tau_{\text{cfs}} \cdot s$ and $F_{\text{des}} = F_{u,5} / \gamma$ Dynamic: 5,350 cycles shall take place without damage to the 5 anchorages tested <i>Method II:</i> $P_{\text{br},0} / P_{\text{br},n} \geq 0.75$ - $F_{\text{des}} = P_{\text{br},n} \times a^2 / 4 \times \gamma$
5.1.4.3.3	Safety devices	6.1.4.3.3	The variety of designs is such that the approval body will decide upon a relevant approach.
5.1.4.4	Opening lights	6.1.4.4	Class according to EN 13115 - After the test, no damage to the structural sealant shall be evident. The windows shall be examined before, during and after the tests, noting the appearance of any defects, for example glazing breakage, detachment, etc.

Reference	Verification methods	Clause n°	Treatment of results and requirements - Criteria
6.1.4 ER4: Safety in Use			
5.1.4.5	Impact tests	6.1.4.5	EN 14019 and EN 13049 No performance-determined option is possible.
6.1.4.6 Test of the structural sealant			
5.1.4.6.1	Gas inclusions	6.1.4.6.1	No visible gas bubbles allowed using normal corrected vision
5.1.4.6.2	Elastic recovery	6.1.4.6.2	Elongation 24 hours after unloading shall be < 5% of the initial elongation.
5.1.4.6.3	Shrinkage	6.1.4.6.3	Shrinkage shall be less than 10%.
5.1.4.6.4	Resistance to tearing	6.1.4.6.4	USE CATEGORY 1 : $\Delta X_{\text{mean}} > 0.75$ kit with insert in the structural seal (e.g. mechanical self-weight support, safety devices, other elements as relevant...) USE CATEGORY 2 : $\Delta X_{\text{mean}} \geq 0.50$ kit without insert in the structural seal
5.1.4.6.5	Mechanical fatigue	6.1.4.6.5	$\Delta X_{\text{mean}} \geq 0.75$; Rupture $\geq 90\%$ cohesive
5.1.4.6.6	U.V. resistance of the sealant	6.1.4.6.6	$\Delta X_{\text{mean}} \geq 0.75$ for elongation and breaking stress
5.1.4.6.7	Elastic modulus of the sealant	6.1.4.6.7	Declared value resulting from the test As a function of the type of curve obtained (a, b, c, d according to Figure 1 of EN ISO 527), the following pairs of values will be given (ϵ_1, σ_1), (ϵ_2, σ_2), (ϵ_m, σ_m), (ϵ_y, σ_y), (ϵ_B, σ_B) $E = \frac{\sigma_2 - \sigma_1}{\epsilon_2 - \epsilon_1}$ The calculation modulus: $E = \frac{\sigma_2 - \sigma_1}{\epsilon_2 - \epsilon_1}$
5.1.4.6.8	Creep under long-term shear and cyclic tensile loading	6.1.4.6.8	For all samples, the maximum relative horizontal displacement 24 hours after unloading is 0.1 mm - movement shall be stabilised after 91 days - the maximum movement measured before unloading shall be compatible with that which the kit can accommodate. - "e" (see Figure 17) is the maximum authorised structural seal width
5.1.4.7	Method of calculating the seal dimensions	6.1.4.7	See ANNEX 2
5.1.4.8	Sill height	6.1.4.8	The range of possible sill heights is noted.

Reference	Verification methods	Clause n°	Treatment of results and requirements - Criteria
6.1.4 ER4: Safety in Use			
5.1.4.9	Wind resistance	6.1.4.9	Windows: Classification according to EN 12210 - Windows and doors - Resistance to wind load - Classification. The maximum deflection of the prototype shall be mentioned in the ETA. Curtain walling: Performance prescription according to EN 13116. The design pressure used in the test shall be mentioned in the ETA. Convener note: the horizontal deflection criteria given in EN 13830 § 4.3.1 contradicts that in ENV 1999
5.1.4.10	Partial collapse in case of fire (see also ER2)	6.1.4.10	Classification according to EN 13501-1, 3, 5 as relevant
6.1.5 ER 5: Protection against noise			
5.1.5	Protection against noise	6.1.5	The applicant shall declare the performance level claimed Rating of sound insulation and presentation of result: EN 717-1 No performance-determined option is possible.
6.1.6			
5.1.6.1	Thermal insulation	6.1.6.1	Aggregate or calculation method / susceptibility to condensation: The results are expressed in accordance with the relevant chapter(s) given in the standard(s) of the chosen method. When the number of component combinations is too large, the necessary information shall be given in the ETA to allow determination of performance (see GP C § 3.4) No performance-determined option is possible. See Clause 6.1.3.1
5.1.6.2	Air permeability	6.1.6.2	No performance-determined option is possible.

(+) 72 - EN 13115:2001: Windows: - Classification of mechanical properties - Racking, torsion and operating forces

(+) 73 - EN 12210:2000 - Windows and doors - Resistance to wind load

(+) 74 - EN 13116:2001 - Curtain walling - Resistance to wind load - Performance requirements

(+) 75 - EN ISO 717-1:1997: Acoustics - Rating of sound insulation in buildings and of building elements - Part 1: Airborne sound insulation (ISO 717-1:1996)

Table 8.4 - **ER5 and ER6**

6.1.7 Durability aspects

It is assumed that the entire testing programme is necessary and sufficient to assess durability.

Reference	Verification methods	Clause n°	Treatment of results and requirements - Criteria
6.2 Verification methods related to the identification of the products			
6.2.1 Structural sealant			
5.2.1.1	Specific mass	6.2.1.1	V _{mean} and S
5.2.1.2	Hardness	6.2.1.2	V _{mean} and S
5.2.1.3	Thermogravimetric analysis	6.2.1.3	Thermogravimetric curve
5.2.1.4	Colour	6.2.1.4	Colour parameters ISO 4660/ ISO 7724
6.2.2 Anodised aluminium structural adhesion surface			
5.2.2.1	Aluminium alloys	6.2.2.1	Chemical composition: The aluminium alloys commonly used in architecture for this type of application are alloys EN AW-6060 and EN AW-6063 to EN 573-3. Other alloys may be used provided they meet the relevant requirement of this Guideline
5.2.2.2	Anodising characteristics	6.2.2.2	
5.2.2.2.1	Measuring thickness	6.2.2.2.1	Minimum average thickness 15 µm
5.2.2.2.2	Sealing tests	6.2.2.2.2	For EN 12373-4: Values from 0-2 on the EWAA/EURAS scale are acceptable For EN 12373-6: Maximum weight loss 30 mg/dm ² For EN 12373-5: the admittance < 20 µS If the anodising on the aluminium alloy has a QUALANOD mark corresponding to the requirements above, it may be taken into account by the approval body Important note: The methods mentioned above are not appropriate to some anodic oxidation processes, especially if coloured. In this case, the approval body shall identify and assess the anodic oxidation using the appropriate methods. If necessary, an alternative method shall be jointly agreed between the manufacturer and the approval body.
6.2.2.3 Description of the anodising process			
5.2.2.3.1	Scouring	6.2.2.3.1	no criteria, description
5.2.2.3.2	Anodic oxidation	6.2.2.3.2	no criteria, description

Reference	Verification methods	Clause n°	Treatment of results and requirements - Criteria
6.2 Verification methods related to the identification of the products			
5.2.2.3.3	Sealing the anodised layer	6.2.2.3.3	no criteria, description
6.2.3 Glass adhesion surface			
5.2.3.1	Identification of the glass	6.2.3.1	Relevant EN for the type of glass
5.2.3.2	Glass product	6.2.3.2	Criteria for the relevant set of applicable tests. See 5.1.4 and 5.2.3.2.
5.2.3.3	Coated glass	6.2.3.3	Only glass coatings A, B, S to EN 1096 are suitable for structural bonding. In addition, the glass coating shall meet the requirements of the relevant set of applicable tests. See clauses 5.1.4 and 5.2.3.3.
6.2.4 Stainless steel adhesion surface -			
5.2.4	Stainless steel alloy	6.2.4	Stainless steel material shall be austenitic alloy, reference X5CrNi18-10 and X5CrNiMo17-12-2 to EN 10088 (304 and 316, according to AISI ASTM) in a condition suitable for bending or welding. Only the tested surface finish may be actually used in practice.

Table 8.5 - Verification methods related to the identification of the products

6.2.5 ER2: Safety in case of fire

6.2.5.1 Reaction to fire

6.2.5.1.1 In the intended end-use conditions

SSGK and its components shall be classified according to EN 13501-1:2007 (to be applied in accordance with the provision of relevant EC Decision).

If all the components of the kit are class A1 without testing according to Decision 96/603/EEC as amended, the whole kit may be classified Class A1 without testing. If one or more of the components is classified according to a CWFT Decision, the whole kit may be classified into the lowest class of any component.

It shall be indicated that, since the SSGK has not been assessed according to facade fire scenarios, an additional demonstration of the fitness for use in this context might still be required in some countries at national level, if the harmonised system is not available.

6.2.5.1.2 Fire from rear side

SSGK and its components are classified according to EN 13501-1:2007 (to be applied in accordance with the provision of relevant EC Decision).

If all the components of the kit are class A1 without testing according to Decision 96/603/EEC as amended, the whole kit may be classified Class A1 without testing. If one or more of the components is classified according to a CWFT Decision, the whole kit may be classified into the lowest class of any component.

6.2.6 Fire resistance

The part of the works or assembled system in which the SSGK is intended to be incorporated, installed or applied shall be classified according to EN 13501-2.

6.2.7 External fire performance

If SSGK are used as roofs, or parts thereof, test results in accordance with TS 1187:2011 shall be used to classify the relevant roof of which the kit forms part of the assembled system, in accordance with EN 13501-5. The ETA shall clearly define the build of the roof receiving this classification.

6.3 Hygiene, health and the environment

6.3.1 Release of dangerous substances

The product and/or constituents of the product listed in the EOTA TR 034: "General Checklist for ETAGs/CUAPs/ETAs Content and/or release of dangerous substances in products/kits" (or equivalent EOTA document), and the related dangerous substances which have to be considered, will be assessed by the given methods taking into account the installation conditions of the construction product and the release scenarios resulting from there.

7 Assumptions under which fitness for use is to be assessed

7.1 General

Chapter 7 sets out the preconditions for design, execution, maintenance and repair that are assumed for assessing fitness for use according to the Guideline (only when necessary and where they have a bearing on the assessment or the products).

In assessing the fitness for use of an SSG kit, the kit should be considered in relation to existing codes of practice for installation, particularly those for glass and glazing. Where particular features of the kit and, in particular, the site installation procedure, are unusual and outside the scope of existing codes, these features shall be noted in the ETA, and details given of the precautions necessary on site to ensure correct installation and therefore the required level of performance.

An overall assumption is made that surfaces deemed suitable for structural bonding will not be rendered unsuitable by unapproved actions during processing; for example, the application of lanolin subsequent to anodising of aluminium is unacceptable.

7.2 Design of the works

In many important respects, the design of a facade incorporating an SSG kit will be specific to the building on which it will be used.

This includes the overall structural performance of the facade, its impact resistance, acoustic performance (where relevant), and hygrothermal behaviour.

The ETA for the SSG kit will indicate the thermal properties of elements of the SSG kit and will give guidance on likely acoustic behaviour. It is to be assumed that specific calculations and, in some cases, tests will be necessary for each application. Similarly, calculations and, if necessary, tests will be required to determine the overall structural adequacy of the facade and that of the structure to which the SSGK components are attached. It is up to the specifier to ensure that the facade as installed in the building will provide the required performance based on the information given in the ETA.

In order for a facade incorporating the SSGK to perform its function, it is necessary for the facade structure to meet the preconditions defined in the ETA (see Chapter 9). The following list indicates likely pre-conditions, but this list is not exhaustive and can be adapted to particular kits:

- There shall be a limit to the acceptable deflection of mullions and transoms
- The joint between mullions and transoms in the facade structure shall resist, without deterioration or permanent deflection, the operational loads and the dead weight of the sealant support frame and the glazing
- The facade structure shall be equipped with expansion joints and be electrically earthed
- The maximum calculated deflection of the structural sealant support frame without glass, between two adjacent anchorages on the same edge (see terminology clause 3.2.01), shall be 1/300 (see also clause 5.1.4.7)

Where a no performance-determined option applies to a kit, the performance requirement can be met by adopting other measures suitable to the work.

If the design of the works means that a particular regulatory requirement (e.g. resistance to fire) is met without any contribution from the SSGK, the ETA holder may declare "NPD" for this characteristic, as long as the installation of the SSGK does not reduce the performance of the entire works.

7.3 Execution of the works

7.3.1 Transport and storage

The approval body shall verify that the manufacturer intends to take suitable precautions during transport and storage to ensure that glazed sealant support frames are protected against damage by, e.g. breakage, scratching, spalling or contamination.

Suitable arrangements shall be made to prevent the application of unacceptable loads to the structural seal, for example by the provision of suitable racks. Or, to prevent exposure to water, solar radiation or significant changes in temperature, protection with covers may be required.

7.3.2 Installation

7.3.2.1 General

The supplier of the SSG kit shall provide detailed instructions regarding fixing the glazed sealant support frame to the facade structure, including the procedure for precise alignment of the units and subsequent weatherproofing.

Installation of the SSG kit shall be possible under normal site conditions. This Guideline requires that all structural bonds are factory made, in well-controlled conditions. However, even when this

important requirement is respected, it is still possible for the long-term integrity of the structural bond to be affected by poor installation. This problem is more likely to arise if the process on site is difficult, requiring an unusually high level of skill and training.

The approval body shall examine the site fixing instructions or advisory arrangements provided by the SSG kit supplier. The purpose of this examination is to ensure that the instructions are adequate to allow installation by site operatives with normal skill levels, with some special training as required. It is expected that certain aspects will always be covered in the instructions: for example, commenting on the need to prevent blockage of drainage apertures when applying a weathering sealant, ensuring the correct positioning of safety devices to avoid concentrated loads on glazing, and the requirements for correct lifting of the units.

During the assessment, it shall be determined whether the design of the kit presents particular difficulties for site installation. Assembly of the samples for air-leakage, wind load and water-leakage testing presents a suitable opportunity for an assessment.

A number of design aspects require particular attention for ease of installation. The following notes draw attention to some of these, but the list should not be considered exhaustive:

- i Site fixing of the mechanical support for glass self-weight.
- ii Site installation of setting blocks [usually in conjunction with i].

The installation sequence (particularly installation of setting blocks) shall not allow the application of undue shear stress to the structural bond.

- iii Dimensional tolerances of interconnecting elements.
- iv Site fixing of safety devices.

7.3.2.2 Weather sealing

The requirements for weather sealing will vary depending on the type of kit used. If a sealant is used, normally it will be necessary to thoroughly prepare the sealing surfaces, apply a primer where specified, insert any backer rod and seal with the specified sealant.

If a preformed gasket is to be used, it will be necessary to ensure that the gasket aperture in the facade is clean and that the tolerances on its dimensions are within the specified limits.

Variations on these procedures shall be examined to ensure that the required performance will be achieved and that the procedure is feasible on site.

7.4 Maintenance and repair

It will be necessary to examine the manufacturer's recommendations for the frequency of cleaning and maintenance of the facade, and the method to be used.

The procedure for cleaning shall allow only the use of those products assessed as compatible with the SSGK components. The use of non-abrasive cleaning tools may be acceptable if no damage to a coating on glass side 1 will result.

Due to the difficulty of quality control during on-site repair, a factory-glazed replacement frame shall be installed. Therefore, it is necessary to make an assessment and comment on the ease of future replacement.

Replacement of weather seals should be done using procedures and materials approved by the SSGK supplier and covered by the ETA.

SECTION THREE: ATTESTATION and EVALUATION OF CONFORMITY

8 Evaluation of conformity

8.1 EC decision

The systems of attestation of conformity of SSGK specified by the European Commission detailed in the EC Mandate are as follows [Commission decision of 24/06/96, published in the EC Official Journal L254 of 08/10/96].

- System 1 (without audit testing of samples) for SSG kits, Types II and IV.
- System 2+ [first possibility, including certification of the factory production control (FPC)] by an approval body on the basis of its continuous surveillance, assessment and approval for SSG kits Types I and III.

[The systems being as described in Council Directive 89/106 EEC, Annex III.2.(i) and (ii) respectively].

Concerning the structural sealants, which are marketed as such, it is impossible to determine in advance the Type of kits in which the sealant is to be used.

As a consequence, only system 1 applies.

System 1

a. Tasks for the manufacturer

- Factory production control
- Testing of samples taken by the manufacturer at the factory in accordance with a prescribed test plan.

b. Tasks for the approval body

- Initial type testing of the product
- Initial inspection of the factory, and of factory production control
- Continuous surveillance, assessment and approval of the factory production control.

System 2+

a. Tasks for the manufacturer

- Initial type testing of the product
- Factory production control

b. Tasks for the approval body

- Initial inspection of the factory, and of factory production control
- Continuous surveillance, assessment and approval of the factory production control

In practice, the operation of systems 1 and 2+ will be very similar for SSG kits, for the following reasons:

a. The results of testing will normally be available as part of the work required for assessing the products for ETA, and these tests normally are used for the purposes of initial type testing

b. The nature of the product is such that testing of samples taken by the manufacturer at the factory will be required under the FPC arrangements.

8.2 Responsibilities

8.2.1 Introduction

The following chapter is relevant to certification of the SSGK and structural sealant products as determined in chapter 8.1

8.2.2 Tasks for the manufacturer

8.2.2.1 Factory production control (for the kit and structural sealant)

The manufacturer shall exercise permanent internal control of production. In the context of the SSG kit, the term manufacturer relates to the company responsible for putting the kit on the market.

All the elements, requirements and provisions adopted by the manufacturer shall be systematically documented as written policies and procedures. This production control system shall ensure that the product is in conformity with the criteria for a European Technical Approval (ETA).

Manufacturers having an FPC system complying with EN ISO 9001 and addressing the requirements of their ETA(s) are recognised as satisfying the FPC requirements of the Directive.

(+) 76 - ISO 9001:2000: Quality management systems - Requirements

8.2.2.2 Testing of samples taken at the factory - Prescribed Test Plan **(for kit and for structural sealant)**

This only concerns taking samples representative of the final product. The testing of "H" pieces and peel tests, as part of the FPC, provide the necessary evidence.

8.2.2.3 Declaration of Conformity (System 2+) **(for kit)**

When all the criteria of the conformity attestation are satisfied, the manufacturer shall make a Declaration of Conformity.

Tasks for the manufacturer or the approval body - Initial type testing

8.2.2.4 ITT for ETA on the kit

Approval tests will have been conducted by the approval body or under its responsibility (may include some tests conducted by a specified laboratory or by the manufacturer witnessed by the approval body) in accordance with Chapter 5 of this ETAG. The approval body will have assessed the results of these tests in accordance with Chapter 6 of this ETAG, as part of the ETA issuing procedure. These tests are normally used for the purposes of Initial Type Testing.

For System 1, this work is validated by the approval body in the framework of the Certificate of Conformity, in particular for the following characteristics (all except water tightness, acoustic insulation and thermal resistance). For System 2+, the Declaration of Conformity activity is taken over by the manufacturer.

8.2.2.5 ITT for ETA on the structural sealant

Approval tests will have been conducted by the approval body or under its responsibility (may include some tests conducted by a specified laboratory or by the manufacturer witnessed by the approval body) in accordance with Chapter 5 of this ETAG.

The following tests shall be performed on at least 2 generic substrates, one metallic and the other glass.

- Chapter 4 Requirements
- Chapter 5 Methods of verification

5.1.4.1 Initial Mechanical Strength

5.1.4.1.1 Tension, rupture

5.1.4.1.2 Shear rupture

- 5.1.4.2 Residual mechanical strength after artificial ageing
- 5.1.4.2.1 Immersion in water at high temperature with or without solar radiation
- 5.1.4.2.2 Humidity and NaCl atmosphere
- 5.1.4.2.3 Humidity and SO₂ atmosphere
- 5.1.4.2.4 Facade cleaning products (optional, can be performed in the framework of the kit)
- 5.1.4.2.5 Effect of material in contact (optional, can be performed in the framework of the kit)

- Chapter 6 Assessing and judging the fitness of products for an intended use

The approval body will have assessed the results of these tests in accordance with Chapter 6 of this ETAG, as part of the ETA issuing procedure. These tests are used for the purposes of Initial Type Testing.

For System 1, this work is validated by the approval body in the framework of the Certificate of Conformity

8.3 Documentation (for kit and for structural sealant)

8.3.1 General

The approval body issuing the ETA shall supply the information detailed below. This information and the requirements given in EC Guidance Paper B will form the basis on which the factory production control (FPC) is assessed by the approval body:

- (i) The ETA
- (ii) Basic manufacturing process
- (iii) Product and materials specifications
- (iv) Test plan as part of FPC
- (v) Other relevant information.

This information shall initially be prepared or collected by the approval body, and shall be agreed with the manufacturer. The following details indicate the type of information required:

8.3.2 Detailed documentation

8.3.2.1 The ETA

See section 4 of this Guideline.

8.3.2.2 Basic manufacturing process

The basic manufacturing process shall be described in sufficient detail to support the proposed FPC methods.

Normally, the correct handling, storage and pre-treatment of SSGK components is critical. Specific requirements are emphasised in the description of the manufacturing process.

8.3.2.3 Product and material specifications

Product and material specifications will be required for the various components, many of which will be bought-in. The information required may take a number of forms, including the following:

- Detailed drawings (including manufacturing tolerances)
- Declaration on raw material specifications
- References to appropriate specifications
- Manufacturer's data sheet

8.3.2.4 Test plan as part of FPC

The manufacturer and the approval body issuing the ETA shall agree on a test plan (CPD Annex III 1b).

An agreed test plan is necessary as current standards relating to quality management systems (Guidance Paper Number B, EN ISO 9001, etc.) do not ensure that the product specification remains unchanged and they cannot address the technical validity of the type or frequency of checks/tests.

The validity of the type and frequency of checks/tests conducted during production and on the final product shall be considered. This will include the checks conducted during manufacture on properties that cannot be inspected at a later stage and checks on the final product. These normally will include:

8.3.2.4.1 In the case of ETA for the structural sealant

Checks on incoming material

The raw materials (sealant constituents of the base and the catalyst when relevant) are identified with internal codes or complete formulations.

The raw material may be received and accepted based on lot certificates provided by the raw material producer and/or reception tests on incoming material.

The purchase specifications of all raw materials shall be made available to the notified body.

Where these raw materials and purchase specifications are considered confidential, a copy signed by the Approval Body responsible shall be made available to the notified body by the manufacturer.

Checks during the fabrication of the structural sealant (on the base and catalyst when relevant)

The method for control of the mixing ratio of the different constituents and the mixing technique(s) shall be identified and scrutinised.

Checks on the finished product: the structural sealant

On the fresh sealant (on the base and on the catalyst when relevant)

Controls on the fresh product(s) are to be analysed. This may be done on the basis of physical characteristics such as flow, viscosity, pH tests, appearances, colour.

The control procedure, the frequencies and criteria shall be recorded.

If the detailed test procedure is considered confidential, a copy signed by the approval body responsible shall be made available to the notified body by the manufacturer.

On the cured structural sealant

On each batch of sealant (production in one run, which can involve several barrels)

Adhesion-cohesion under tension to rupture, on float glass and on a reference metal (aluminium or stainless steel).

Six test pieces in the case of conditioning C1, or nine test pieces in case of conditioning C2, in accordance with Figure 6, are manufactured and stored according to the structural sealant manufacturer's instructions.

These three test pieces are then subjected to a tensile test to rupture.

The remaining test pieces are subjected to one of 2 alternative conditionings:

- C1: 3 test pieces - immersion in water at $(95 \pm 2)^\circ\text{C}$ for 24 hours.
- or
- C2:
 - 3 test pieces: immersion in water at $(23 \pm 2)^\circ\text{C}$ for 7 days

- 3 test pieces: in an oven at $(100 \pm 2)^\circ\text{C}$ for 7 days

They are then conditioned for (48 ± 4) hours at a temperature of $(23 \pm 2)^\circ\text{C}$ and $(50 \pm 5)\%$ relative humidity. The conditioned test pieces C1 or C2 are then subjected to the tensile tests to rupture.

Table 9 - Treatment of results and requirements

Tests	Treatment of results and requirements
For C1 (3 test pieces) or for C2 (6 test pieces) Adhesion-cohesion under tension to rupture before and after immersion in water	Rupture 90% cohesive Rupture value to be checked and noted. The minimum rupture value under the defined test conditions (T° , R.H., ...) is to be provided by the sealant manufacturer.

8.3.2.4.2 In the case of ETA for the SSG kit

1° - Checks on incoming material

The documentation shall make it clear that the incoming material corresponds to that listed in the ETA.

If incoming material or components are manufactured and tested by the supplier in accordance with agreed methods, further testing by the SSG kit manufacturer usually is not necessary. If the supplier does not conduct such tests, the kit manufacturer shall conduct appropriate checks/tests before acceptance.

- (i) On each batch of sealant (production in one run, which can involve several barrels)

When the structural sealant(s) are not covered by an ETA and CE marking, the tests on cured sealant required in the framework of the ETA on structural sealant are to be performed.

- (ii) On each batch of anodised aluminium (e.g. group of aluminium profiles anodised in the same bath at the same time for one day maximum)

Anodising manufacturers having a certification and FPC system complying with the Qualanod label and addressing the requirements of the ETA are recognised as satisfying the FPC requirements of the Directive with respect to anodising.

One electrical measurement per batch of the admittance and thickness of the anodising will demonstrate the consistency and conformity of the anodising to the ETA, for one batch and between several batches:

Method for characterising surface properties of the anodised aluminium layer:

Two properties have been selected to check the stability of anodised aluminium profiles:

- The thickness of the aluminium oxide layer
- The level of sealing, i.e. the level of surface porosity.

The thickness of the aluminium oxide layer is measured using the same methods (at least one) as used during ITT (see the method in clause 5.2.2.2.1)

- (iii) On stainless steel

The certificate provided by the stainless steel producer is used to establish that the stainless steel product supplied for the project is identical to the product described in the ETA (the alloy and the surface finish). No specific test is required. If necessary, the approval body can request the relevant performance report from the initial type testing.

- (iv) On glass

No specific test is required.

- (v) On coated glass

No specific test is required. The technical file accompanying the coated glass delivery shall include a declaration that the coated glass is manufactured in accordance with classes A, B, S of the EN 1096 series.

(vi) On insulating glass units

No specific test by the ETA holder is required.

However, it shall communicate the IGU specifications to the supplier so that IGUs can be manufactured in accordance with the ETA, providing at least the following information:

If the outer edge seal has no structural function:

- The list of IGU sealant(s) compatible with the SSGK kit,
- The dimensional tolerances (in relation to the essential requirements) applicable to the IGU,
- Essential characteristics, in deviation from EN 1279-1,
- ...

Additional information if the outer edge seal has a structural function:

- $R_{u,5}$, the characteristic breaking stress of the IGU structural sealant(s),
- Dimensions and tolerances of the bite of the structural edge seal or the detailed calculation method for the bite of the structural edge seal, its permissible tolerance and the value of the variable to be used in the calculation method.
- The list of coatings to which the structural edge sealant can be applied (on faces 2, 3 of the IGU)
- The list of the coatings to which the structural sealant can be applied (on stepped IGU face 2, non-stepped IGU face 4),
- others, ...

The technical file accompanying the IGU delivery shall include:

- A declaration that the IGUs are manufactured in accordance with the EN 1279 series
- A declaration that the IGUs are manufactured in accordance with ETA specifications provided by the ETA holder:

Additionally, if the outer edge seal has a structural function:

- A summary of the test records collected during the factory production control of the IGU:
- The test programme shall either conform to Table 10 (Table 10, point 3, in this case not relevant), or it shall be as described in EN 1279-6, Annex F with the following modifications:
 - Sample
Geometry: described in EN 1279-6, Annex F, Fig. F.2, "glass, glass sample"
The glass samples shall be coated for the present project.
 - The test procedure: EN 1279-6, Annex F, § F.3.3, shall be modified as follows:
The tensile test shall be continued until rupture of the sample.
Minimum requirement: rupture 90% cohesive.
Rupture value to be checked and noted. The minimum rupture value under the defined test conditions (T°, R.H., ...) shall be provided by the sealant manufacturer.
Special delivery conditions may demand that the above requirement be set at a higher level.
Frequency: Three samples in the morning, three in the afternoon and three samples at each packaging change (each time a component to be assembled comes from a different package, e.g. for the sealant, each time a new barrel is opened)

(+) 77 EN 1279-6:2002 - Glass in building. Insulating glass units. Factory production control and periodic tests

2° - Checks on suitability for bonding of structural sealant on anodised aluminium

Those tests are to be performed prior to bonding runs on aluminium anodising. Normally, the result of these checks remains valid for 6 months from the anodising date if the aluminium is stored in a

dry condition (relative humidity 60%). If not stored in suitable conditions, the test in clause 1° shall be conducted.

Depending on the deviation contained in the previous results, for example with respect to voluntary certification for applying structural sealant to the anodising, it is possible to also control the fitness for bonding of the anodised aluminium for each batch

Adhesion-cohesion under tension to rupture of one reference batch of the structural sealant referred to in the ETA and on each bath of aluminium (e.g. group of aluminium profiles anodised in the same bath at the same time for one day maximum)

Six test pieces in the case of conditioning C1, or nine test pieces in case of conditioning C2, in accordance with Figure 6, are manufactured and stored according to the structural sealant manufacturer's instructions.

These three test pieces are then subjected to a tensile test to rupture.

The remaining test pieces are subjected to one of 2 alternative conditionings:

- C1: 3 test pieces - immersion in water at $(95 \pm 2)^\circ\text{C}$ for 24 hours.
- or
- C2:
 - 3 test pieces: immersion in water at $(23 \pm 2)^\circ\text{C}$ for 7 days
 - 3 test pieces: in an oven at $(100 \pm 2)^\circ\text{C}$ for 7 days

They are then conditioned for (48 ± 4) hours at a temperature of $(23 \pm 2)^\circ\text{C}$ and $(50 \pm 5)\%$ relative humidity. The conditioned test pieces C1 or C2 are then subjected to the tensile tests to rupture.

Table 10 - Treatment of results and requirements

Tests	Treatment of results and requirements
For C1 (3 test pieces) or for C2 (6 test pieces) Adhesion-cohesion under tension to rupture before and after immersion in water	Rupture 90% cohesive Rupture value to be checked and noted. The minimum rupture value under the defined test conditions (T° , R.H., ...) is to be provided by the sealant manufacturer.

Note: for the other types of substrate (stainless steel, glass, ...), no test equivalent to (ii) is necessary.

3° - Checks during the application of structural sealant.

Table 11 - Checks necessary over a two-day production cycle

Production date: Company:		Project reference:			
	First day, third day, fifth day		Second day, fourth day, sixth day		Packaging change
	Morning	Afternoon	Morning	Afternoon	
<u>1. General</u> extrusion machine cleaning (1)	reference to cleaning solvent	not applicable	not applicable	not applicable	reference to cleaning solvent
temperature (°C)	value	value	value	value	not applicable
relative humidity (%)	value	value	value	value	not applicable
<u>2. Structural sealant</u> silicone lot number for 2 comp, base + catalyst	reference	not applicable	reference	not applicable	reference
base / catalyst ratio (1), (3)	ratio value	ratio value	ratio value	ratio value	ratio value
glass plate (marble) test (1), (2)	pass/fail	pass/fail	pass/fail	pass/fail	pass/fail
<u>3. Metal</u> type lot number surface finishing	alloy reference type	not applicable not applicable not applicable	not applicable not applicable not applicable	not applicable not applicable not applicable	alloy reference type
cleaning product name and lot number	reference	not applicable	not applicable	not applicable	reference
if any - primer name and lot number	reference	not applicable	not applicable	not applicable	reference
<u>4. Glass</u> surface finishing (5)	coating reference	not applicable	not applicable	not applicable	coating reference
cleaning product name and lot number	reference	not applicable	not applicable	not applicable	reference
if any - primer name and lot number	reference	not applicable	not applicable	not applicable	reference
<u>5. Adhesion testing on H - pieces (4)</u> sample 1 curing time: ... rupture ≥ 90% cohesive rupture 100% cohesive tensile strength (N)	H - pieces (4) value pass/fail not applicable value	<u>Peel test (6)</u> on glass value not applicable pass/fail not applicable	<u>Peel test (6)</u> on glass value not applicable pass/fail not applicable	<u>Peel test (6)</u> on glass value not applicable pass/fail not applicable	H - pieces (4) value pass/fail not applicable value
sample 2 curing time: ... rupture ≥ 90% cohesive rupture 100% cohesive tensile strength (N)	value pass/fail not applicable value	on metal value not applicable pass/fail not applicable	on metal value not applicable pass/fail not applicable	on metal value not applicable pass/fail not applicable	value pass/fail not applicable value
sample 3 curing time: ... rupture ≥ 90% cohesive rupture 100% cohesive tensile strength (N)	value pass/fail not applicable value	not applicable	not applicable	not applicable	value pass/fail not applicable value

Table 11 notes

(1) Only for two-component silicones

(2) The glass plate (marble) test is used to check the homogeneity of the mixture.

A quantity of silicone product (mixed by the pump) is placed on one glass plate and squeezed by placing a second glass plate on top. If grey or white traces are visible, this indicates insufficient mixing, in which case bonding shall not commence until further mixing has been done and a successful glass plate test has been conducted.

(3) All two-component mixing equipment incorporates two tubes in which small quantities of base and catalyst can be placed to check that the actual mix ratio is compliant.

The H pieces are test pieces of silicone (12 x 12 x 50 mm) between two substrates. The samples shall be made with the products actually used in the project (metal and surface finishing, glass and coating, structural sealant). The coated glass manufacturer shall furnish the bonding company with the samples necessary to allow the bonding company to perform the tests in accordance with Table 11.

Shaping of the test pieces can be assisted by e.g. treating wooden blocks with a soap solution to avoid adhesion of the silicone, or with spacer tape with release paper retained in place. With single component sealant, it shall be ensured that spacers are not air and vapour tight; otherwise, curing of the silicone may not take place.

(4) The H test pieces are subjected to tensile test to rupture. The minimum rupture value is to be provided by the sealant manufacturer. As soon as the first H test piece obtains a satisfactory result, the remaining test pieces are not tested and are stored for possible further testing.

(5) Where a special type of coated thermally-strengthened or heat-strengthened glass is prescribed in the project specifications, the glass manufacturer shall furnish the bonding company with the samples of coated float glass necessary for testing in accordance with Table 11.

(6) Peel test description

The peel test samples shall be made with the products actually used in the project (metal and surface finishing, glass and coating, structural sealant). The coated glass manufacturer shall furnish the bonding company with the samples necessary to allow the bonding company to perform the tests in accordance with Table 10.

The peel test samples are made as follows (see Figure 19):

Two short pieces of bond breaker are placed on the substrate, 200 mm apart. A bead of structural sealant about 25 x 6 x 250 mm in length is extruded between the bond breakers in accordance with Figure 19.

The peel test samples shall be stored under the same environmental conditions as the manufactured elements during production. After the minimum curing time as provided by the manufacturer, the structural sealant bead is peeled as follows:

The bead is detached from the substrate at one end and manually peeled back at 180° until rupture of the bead occurs. When rupture occurs, the next peel test is initiated via cuts with a knife at the interface structural seal/substrate or at the other end of the bead.

Cutting and peeling is repeated until the bead is totally peeled off the substrate.

The failure pattern is assessed. 100% cohesive failure is required (adhesive failure is unacceptable - see Figure 20).

A peel test may always be replaced by tests of H pieces (see point (4) above).

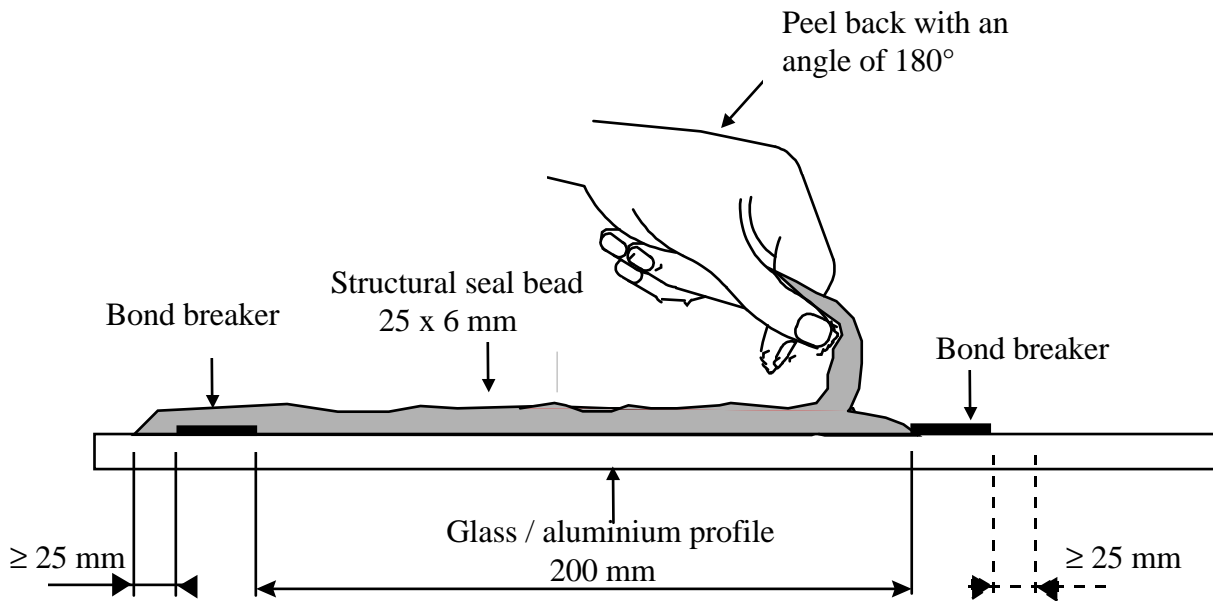

Figure 19 - Peel test description

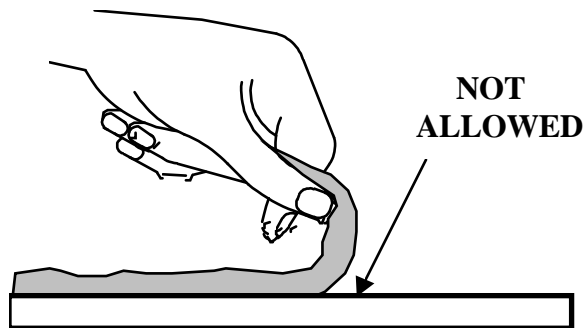

Figure 20 - Unacceptable failure pattern

4° - Checks on assembled SSG elements

The list of checks given below is not exhaustive and may be adapted in each individual case:

- Visual inspection of the finished element (verification that gas inclusions are not present)
- Checks on the joint dimensions
- Glass assembly as a function of the specification
- Relative position of the bonded element
- Correct provision of drainage/pressure equalisation as required by the specification
- Correct fixing of mechanical devices
- Correct provision and placing of spacers, if these are factory fitted

8.4 Prescribed test plan for the bonding workshop

8.4.1 General

The 'bonding workshop' referred to in these paragraphs concerns all bonding workshops operating under CE marking, i.e. the cladding specialist's internal bonding facilities or those of its subcontractors.

The notified certification body knows the potential performance of the kits based on the approval testing programme conducted on samples by the kit designer. The question that needs to be answered is: "Can the cladding specialist reproduce the level of performance obtained during the ITT on the kit designer's representative assemblies?"

When a bonding workshop is involved for the first time in bonding work that is part of the manufacturing process for the SSGK kit having an ETA, the NB shall perform the following procedures:

- Verification that the FPC of the cladding specialist addresses correct procedures to produce efficient facades, in accordance with the minimum requirements specified in the ETA.
- Perform or witness a short and efficient test (see clause 8.4.2) to establish, with sufficient confidence, that the bonding workshop is able to reproduce the performance of the bonding tested during the ETA assessment.

8.4.2 Test procedure assessing a bonding workshop

The test procedure to be used is the test already required in the ETA Guideline, chapter 8 "FPC" to verify the properties of the structural sealant. The same test procedure serves to demonstrate that the bonding workshop is able to carry out correct bonding work. The number of test pieces is increased to 20 to make the assessment statistically significant.

Adhesion-cohesion under tension to rupture, on float glass and on a reference metal (aluminium or stainless steel)

Conditioning alternative 1

Twenty test pieces, in accordance with Figure 6 in ETAG 002 part 1, are made and stored according to the structural sealant manufacturer's instructions.

Ten test pieces are then subjected to a tensile test to rupture in the initial state.

The ten remaining test pieces are immersed in water at $(95 \pm 2)^\circ\text{C}$ for 24 hours. They are then conditioned for (48 ± 4) hours at a temperature of $(23 \pm 2)^\circ\text{C}$ and $(50 \pm 5)\%$ relative humidity. These three test pieces are then subjected to the tensile test to rupture.

Conditioning alternative 2

Twenty test pieces, in accordance with Figure 6 in ETAG 002 part 1, are made and stored according to the structural sealant manufacturer's instructions.

Ten test pieces are then subjected to a tensile test to rupture in the initial state.

Eight test pieces are immersed in water at $(23 \pm 2)^\circ\text{C}$ for 7 days

Four test pieces are conditioned in an oven at $(100 \pm 2)^\circ\text{C}$ for 7 days

They are then conditioned for (48 ± 4) hours at a temperature of $(23 \pm 2)^\circ\text{C}$ and $(50 \pm 5)\%$ relative humidity. These three test pieces are then subjected to the tensile test to rupture.

Tests	Treatment of results and requirements
Adhesion-cohesion under tension to rupture Conditioning alternatives 1 and 2	Rupture 90 % cohesive - $\Delta X_{\text{mean}} \geq 0.75$ test at $+23^\circ\text{C}$ Rupture value to be checked and noted. The minimum rupture value under the defined test conditions (T° , R.H.,...) is to be provided by the sealant manufacturer.

Table 11 - Treatment of results and requirements

8.5 Organisation of the certification - Route to CE marking

Guidance document NB-CPDSG05 03 007 endorsed by the EC services explains how to certify the conformity of the product to an ETA, following the three manufacturing routes most often used. If other routes are used, an appropriate certification of conformity scheme shall be specified in the ETA (or in supporting document(s)) such that the relevant tasks are performed, possibly using a case-by-case approach, taking into account the fact that CE marking is not an instrument to be imposed on the market or a particular organisation, but ensuring that all responsibilities related to CE marking are clearly allocated for a given solution. The notified body will work accordingly.

8.6 CE marking and information

According to the CPD, Annex III, paragraph 4.

Marking, labelling and further information (content and format) are to be provided by the manufacturer in addition to the ETA publication, in conformity with CE Guidance Paper D on CE marking.

Example

	<p>"CE" symbol</p>
<p>A</p> <p>Any Company Rue du Producteur, 50 Country</p> <p>xx xxxx-CPD-xxxx</p>	<p>Xxxx Number of Notified Body</p> <p>Name and address of the manufacturer or its representative established in the EEA and of the plant where the product was manufactured</p> <p>Two last digits of year of affixing CE Marking Number of EC Certificate of Conformity</p>
<p>ETA No. XX/XXXX ETAG 002, Parts 1 and 2 Structural sealant glazing system</p> <p>Type X Resistance to tearing: use category x (for sealant only)</p>	<p>ETA Number ETAG reference and date of publication</p> <p>Relevant performance characteristics and/or designation code for Type of mechanical design for structural kits: I to IV Resistance to tearing: use category for ETA on structural sealant only: use category 1 or 2</p>

SECTION FOUR: ETA CONTENT

This section applies to all ETAG 002 parts

9 ETA content

9.1 ETA Content for SSGK

The format of the ETA shall be based on the Commission Decision of 22/7/97 - EC Official Journal L236 of 27/08/97.

For an SSG kit, the following information shall be provided as a minimum:

9.1.1 Performance

- The SSGK type and product description (reference Section One, 2.1.1)
- Reaction to fire, resistance to fire and external fire performance
- Use categories (where relevant) in relation to low temperatures
- Performance characteristics in relation to wind resistance, air tightness and watertightness, partial collapse in case of fire, thermal performance, impact resistance, acoustic performance and release of dangerous substances.

No performance-determined options are possible for some of these characteristics (see Tables: 8.1 to 8.6)

For dangerous substances falling under the scope of the CPD for which:

- no assessment and verification methods are given (or cannot be found in TR 034); or
- "npd" is declared; or
- the chosen verification and assessment method does not comply with the regulatory requirement of a particular Member State

there might be the necessity for an additional assessment.

9.1.2 Specification

The ETA shall show a horizontal and vertical cross section of a typical assembly and shall contain, as a minimum, the following details of the SSG kit.

9.1.2.1 Dimensions

The following dimensions shall be provided, together with tolerances where relevant.

- For the glass

Thickness and maximum overall dimensions with tolerances including flatness

- For IGUs

The glass details (as above) and the unit width.

- For the sealant support frame

External dimensions, with tolerances of squareness, flatness and straightness of members

- For the module formed by transoms and mullions

External dimensions, with tolerances of squareness

- For all metal sections and preformed sealing profiles

Cross section details and major dimensions

- For the assembled kit

Centre-to-centre distance between anchorages of the structural sealant support frame to the facade structure.

9.1.2.2 Components and accessories

The following general details of the major component and accessory specifications shall be given in the ETA:

- Structural sealant
 - The manufacturer and type designation
 - The instructions for applying the sealant, in particular
 - Working time
 - Skin-over time and tack-free time
 - Time before handling
 - Mechanical characteristics ($R_{u,5}$; σ_{des} ; τ_{des} ; τ_{∞} ; E_0 ; ...)
- The generic and specific type of substrates
 - Glass
 - Information necessary for identification (standard references, etc.)
 - Where relevant, details of coatings by layers and for IGUs by surface
- Aluminium and anodising/stainless steel and surface finishes
 - The designation of the aluminium or the metallic alloy
 - Anodising or surface finishing characteristics.
- Weather seal
 - Identification of the material used (gasket, sealant, etc.)
 - Cross section in the case of a pre-formed gasket
- Backer rod

Identification of the material used

- Spacer

Identification of the material

- Setting and location blocks
 - Type of material
 - Shore hardness
- Mechanical self-weight support

Description of geometry and materials used

- Anchorage of the sealant support frame to the façade

Description of geometry and materials used

- Retaining devices (where used)

Description of geometry and materials used

- Opening-light hardware
 - General type details
 - Type of material and protection against corrosion
- Sill height: special devices, if any, and the range of possible sill heights are noted

In addition to the above, the ETA shall contain details of the approach used in calculating the structural seal and give the minimum permissible dimensions.

The ETA shall also contain any details of the installation that the approval body considers worthy of note, as described in Chapter 7 of this Guideline, and details of the maximum acceptable deflection in the facade structure.

9.1.3 Dangerous substances.

In section II.2 Characteristics of products and methods of verification, the ETA shall include the following note:

“In addition to the specific clauses relating to dangerous substances contained in this European Technical Approval, there may be other requirements applicable to the products falling within its scope (e.g. transposed European legislation and national laws, regulations and administrative provisions). In order to meet the provisions of the EU Construction Products Directive, these requirements need also to be complied with, when and where they apply.”

9.1.4 Additional information

9.1.4.1 Content of the ETA technical file to be made available to other Approval Bodies (in addition to the information in the ETA).

9.1.4.1.1 Structural sealant

The file shall contain the following information:

- Reports of tests required, according to the details in Table 8
- Identification of the cleaning products tested according to clause 5.1.4.2.4
- Manufacturer’s specifications regarding application of the sealant

If the hermetic seal of the insulating unit acts as a structural seal, the information stated above is to be provided regarding the silicone sealant of the hermetic seal.

9.1.4.1.2 Glass

For the glass used to perform the tests described in clauses 5.1.4.1, 5.1.4.2 and 5.1.4.6, the file shall contain the following information:

- Reports of the tests required, according to the details in Table 8

9.1.4.1.3 Aluminium and anodising

For the aluminium used to perform the tests mentioned in clauses 5.1.4.1, 5.1.4.2 and 5.1.4.6, the file shall contain the following information:

- The characteristics of the anodisation, required in clause 5.1.4.2
- The shape of the aluminium adhesion surface
- Certificate of production under the Qualanod label, if any

The name of the anodising firm

The name of the primer and cleaning product applied before bonding

- Reports of tests required according to Table 8

9.1.4.1.4 Weather seal

- If applicable, the reports of material compatibility in accordance with clause 5.1.4.2.5
- Report of compatibility with the cleaning product(s)
- The necessary test report or the justification of fitness for use of the product in the particular SSGK (see clause 4.8).

9.1.4.1.5 Backer rod

- If applicable, the reports of material compatibility tests in accordance with clause 5.1.4.2.5
- The necessary test report or the justification of fitness for use of the product in the particular SSGK (see clause 4.8).

9.1.4.1.6 Spacer

- If applicable, the reports of material compatibility tests in accordance with clause 5.1.4.2.5
- Identification of the material
- The necessary test report or the justification of fitness for use of the product in the particular SGSS (see clause 4.8)

9.1.4.1.7 Setting and location blocks

- If applicable, the reports of material compatibility tests in accordance with clause 5.1.4.2.5.

9.1.4.1.8 Mechanical self-weight support

- If applicable, the reports of the bearing capacity test in accordance with clause 5.1.4.3.1
- If applicable, a calculation of the bearing capacity

9.1.4.1.9 Anchorage of the sealant support frame on the facade structure

- If applicable, the reports of the bearing capacity test in accordance with clause 5.1.4.3.2
- If applicable, a calculation of the bearing capacity

9.1.4.1.10 Retaining devices

- Description of the investigations made to ensure that the devices will not damage the glazing

9.1.4.1.11 Opening light hardware

- Basis for the acceptance of any components specifically covered by the ETA

9.1.4.1.12 SSG kit

The file shall contain the following information:

- Full description of the prototype used for whole kit testing
- Details for accommodating building movement
- Handbook for construction and maintenance of the facade

9.1.4.1.13 Stainless steel

- Alloy
- Surface finishing

9.1.4.2 Supplementary information to be provided to approval bodies (together with a copy of the ETA) for the purposes of evaluating conformity.

- Details of the manufacturing process, noting particular points of importance
- Details of components and suppliers, with standard references, where relevant (but excluding confidential details such as formulations)
- Details of sub-contractors providing services such as structural bonding

9.2 ETA content for structural sealant

The format of the ETA shall be based on the Commission Decision of 22/7/97 - EC Official Journal L236 of 27/08/97.

For structural sealants, the following information shall be provided as a minimum:

- The structural sealant use (reference Section One, 2.1.2) as bonding of IGU to the structural seal support frame and/or as IGU hermetic edge seal.
- Reaction to fire

- Use categories (where relevant) in relation to low temperatures.
- The following design and setting information
 - Design stress in tension: σ_{des}
 - Design stress in dynamic: shear: τ_{des}
 - Elastic modulus in tension or compression tangential to the origin: E_0
 - Elastic modulus in shear tangential to the origin G_0
 - Working time (at 25°C, 50% R.H.)
 - Skin over time (at 25°C, 50% R.H.)
 - Tack-free time (at 25°C, 50% R.H.)
 - Time before transport of the bonded frame
 - λ -value
- The identification characteristics as required in clause 5.2.1
 - Single or bi-component
 - Specific mass
 - Hardness A
 - Thermogravimetric analysis
 - Colours
- The product for preparing the structural sealant adhesion surfaces
 - Cleaning product (to clean the adhesion surface before the bonding operation)
 - Primer, if any
 - Facade cleaning product (to clean and maintain the facade)
- The general manufacturing instructions
- The suitable substrates for bonding

The ETA will mention the generic and specific (when relevant) types of structural seal adhesion substrates it covers, and detail the complementary assessment to be done in the framework of the kit ETA when the specific substrate is not mentioned in the ETA for the sealant.

The specific substrates shall be defined using manufacturer identification, brand names, part numbers, etc. When mentioning a typical substrate in a structural sealant ETA, the approval body shall insure that all the information (identification and fitness for use assessment) requested by the present ETAG 002 part 1 § 5.2 (glass products, anodised aluminium, stainless steel) has been verified accordingly and is present in the assessment file.

The generic substrates shall be defined using generic specifications such as European Standards.
- Specifications on the structural sealant application
- If relevant, the chemically compatible products such as backer rod, weather sealant, gasket material etc.

9.2.1 Dangerous substances.

In section II.2 Characteristics of products and methods of verification, the ETA shall include the following note:

“In addition to the specific clauses relating to dangerous substances contained in this European Technical Approval, there may be other requirements applicable to the products falling within its scope (e.g. transposed European legislation and national laws, regulations and administrative provisions). In order to meet the provisions of the EU Construction Products Directive, these requirements need also to be complied with, when and where they apply.”

9.2.2 Additional information

9.2.2.1 Content of the ETA technical file to be made available to other Approval Bodies (in addition to the information in the ETA).

The file shall contain the following information:

Reports of tests required, according to the details in Table 8, as detailed in the § of the present ETAG:

- Adhesion/cohesion test, once on each generic type of substrate
 - Clauses 5.1.4.1.1, 5.1.4.1.2, 5.1.4.2.1, 5.1.4.2.2, 5.1.4.2.3,
- Physical properties, once with the substrates described in the relevant §, if any
 - Clauses 5.1.4.6.1, 5.1.4.6.2, 5.1.4.6.3, 5.1.4.6.4, 5.1.4.6.5, 5.1.4.6.7,
 - If option clause 5.1.4.6.6 and/or clause 5.1.4.6.8 is chosen
- Identification of structural sealant (in this case, independent of any substrates)
 - Clauses 5.2.1.1, 5.2.1.2, 5.2.1.3, 5.2.1.4
- If relevant, identification of the facade cleaning products tested according to clause 5.1.4.2.4 and the test report
- If relevant, identification of the compatible material tested according to clause 5.1.4.2.5 and the test report
- The reference specification (EN, guide, ...) to which the different generic substrates conform
- Manufacturer's specifications regarding application of the sealant.

Additional tests required in the case of extension of fitness for use to specific substrates

In the case of anodised aluminium

- Adhesion/cohesion test
 - Clauses 5.1.4.1.1 only at 20°C, 5.1.4.2.1, 5.1.4.2.2, 5.1.4.2.3,
- Identification, characterisation, and process description required by section 5.2.2
- In the case of coated glass used as structural seal adhesion surface
 - Adhesion/cohesion test
 - Clauses 5.1.4.1.1 only at 20°C, 5.1.4.2.1, 5.1.4.2.2, 5.1.4.2.3,

Important note: in order to avoid test repetition, the coated glass chosen for the test should be representative of the family as defined in 5.2.3.3.2.

- Identification, characterisation, and process description required by section 5.2.3.3.2
- In the case of stainless steel
- Adhesion/cohesion test
 - Clauses 5.1.4.1.1 only at 20°C, 5.1.4.2.1, 5.1.4.2.2, 5.1.4.2.3,
- Alloy and surface finishing

In the case of coated aluminium, ETAG 002 part 2 is fully applicable

ANNEX 1 - STIFFNESS

This annex describes the linearisation method for the tension curves. It can be used for the elastic area of the material and for materials with a Poissons' ratio of approximately 0,5 (normal for sealants used in SSGK). This method has the following advantages:

- Greater accuracy for the modulus with a reduced number of test samples
- Verification of the relationship between the tensile, compressive and shear stiffness of the same material
- Greater reliability in applying the calculation models

A typical curve of deformation under tension is shown in figure A1.1. This curve shows irregularities. Given the application of a certain amount of pre-stressing, determination of the zero point can give rise to difficulties and affect the precision of the stiffness at different elongations. An improvement can be gained by linearising the curve in the elastic area of the structural sealant.

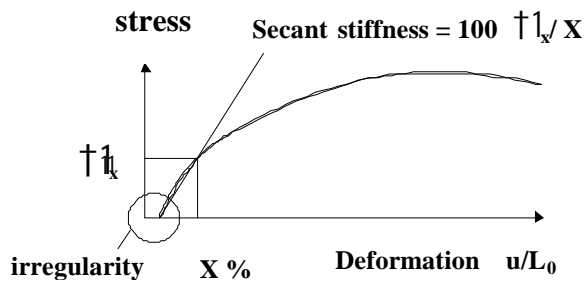

Figure A1.1 Secant stiffness

The linearisation is produced by a conversion of the deformation. For an initial length (L_0) of the test piece and the length of the loaded test piece (L , where $L = L_0 + \text{deformation}$), the scale for the deformation is expressed as:

$$\frac{u_c}{L_0} = \frac{(a - 1/a^2)}{3} \text{ where } a = L/L_0 \text{ (1)}$$

When this technique is applied to several points on the curve, a converted line of regression stress/deformation is obtained, the slope of which represents the tangent stiffness (K_0) at the origin.

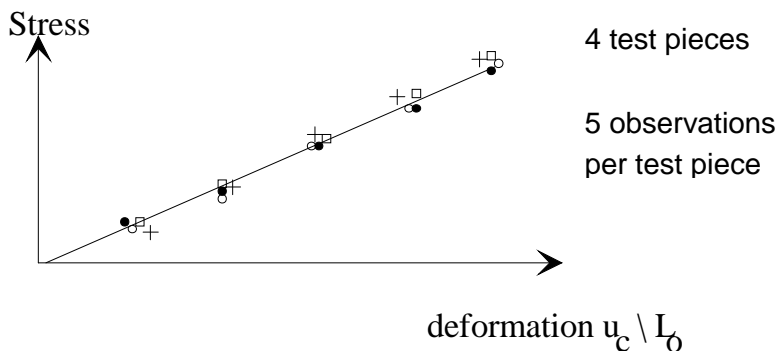

Figure A1.2 - Stress/deformation converted line of regression

(1) Paul Flory, Principle of polymer chemistry. Cornell Univ. Press, Ithaca, N. Y., USA (1953)

K_0 can be calculated directly from the measured points as follows:

$$K_0 = \sum_{i=1}^m \sum_{j=1}^m \frac{K_{ij}}{m \times n} \quad \text{with} \quad K_{ij} = \frac{3 \times \dagger_{ij}}{a_{ij} - 1/a_{ij}^2} ; \quad a_{ij} = \frac{e_i + u_{ij}}{e_i}$$

where:

- m = number of observations per test piece
- n = number of test pieces per test for the temperature concerned
- u_{ij} = the displacement under tension or compression ($e_i + u_{ij}$ represents L)
- e_i = the initial thickness per test piece representing L_0
- \dagger_{ij} = the tensile stress at the tensile displacement u_{ij} .

The relationships between the tangent stiffness at the origin on one hand and the secant stiffness on the other are defined and given in Table A.1.

Table A.1

Conversion of the elongation related to tension or displacement related to compression (u/L_0) for values of converted deformation (u_c/L_0)	
u/L_0 values	u_c/L_0 values = $(a - 1/a^2)/3$ ($a = L/L_0$)
0	0
0,05	0,048
0,10	0,091
0,125	0,112
0,15	0,131
0,20	0,169
0,25	0,203
0,30	0,236
0,35	0,267
0,40	0,297
0,45	0,325
0,50	0,352
0,55	0,378
0,60	0,403
0,65	0,428
0,70	0,451
0,75	0,474
0,80	0,497
0,85	0,519
0,90	0,541
0,95	0,562
1,00	0,583

The relationship between the secant stiffness and tangent stiffness at the origin is:

$$K_{\text{sec}} = K_0 \times \left(\frac{\frac{u_c}{L_0}}{\frac{u}{L_0}} \right)$$

ANNEX 2 - METHOD OF CALCULATION

A2.0 Introduction

This calculation method is based on 7 years experience with silicone.

An applicant, however, may present a different method of calculation based on simulation tests or research results. To allow the approval body to issue an ETA based on such an alternative calculation method, full justification shall be given. Confirmation tests, calculations and/or simulation may be required by the approval body.

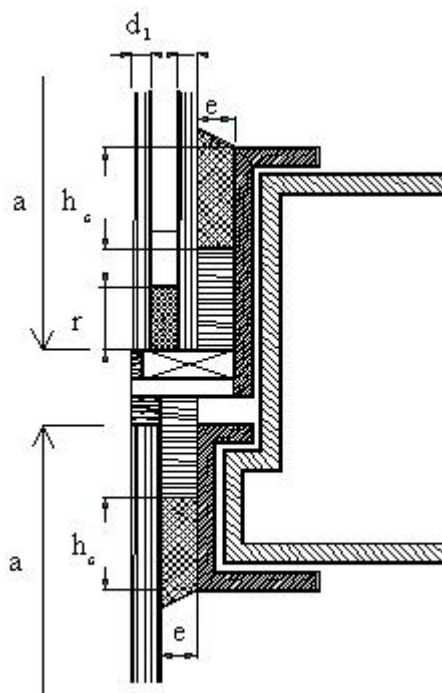

Figure A2 - Vertical section

A2.1 list of symbols

W	=	relevant combined actions of the wind, the snow, self-weight (Pa)
\dagger_{des}	=	tension design stress $\dagger_{des} = R_{u,5} / \chi_{tot}$ ($R_{u,5}$ given in clause 6.1.4.1.1 (23 °C))
X_{des}	=	shear design stress under dynamic load $\Gamma_{des} = R_{u,5} / \chi_{tot}$ ($R_{u,5}$ given in clause (23 °C))
$X_{\dot{c}}$	=	shear design stress under permanent load $X_{\dot{c}} = X_{des} / \chi_c$ (see clause 5.1.4.6.8)
E	=	modulus of elasticity in tension of the silicone, given by the test in clause 5.1.4.6.7
	=	the maximum thermal movement, as a combination of elongation in directions a and b
a	=	short side dimension of the glass pane
b	=	long side dimension of the glass pane
h_v	=	glazing height = vertical dimension a or b
χ_{tot}	=	total safety factor γ_{tot} = nationally determined parameter (6 can be used)
T_c	=	temperature of the metallic frame at moment t
T_v	=	temperature of the glass at moment t
T_0	=	temperature during silicone application
Γ_c	=	linear coefficient of thermal expansion of the structural sealant support frame
Γ_v	=	linear coefficient of thermal expansion of glass
e	=	thickness of the seal

UT	=	$T_c - T_v = 25^\circ\text{C}$ in the case under consideration (see also clause 4.4.4.1)
h_c	=	bite, see also terminology
r	=	bite of the hermetic seal having a structural function
G	=	shear modulus $G = E/3$
P	=	glazing self-weight
d_1	=	outer glass thickness of the IGU
d_2	=	inner glass thickness of the IGU
d	=	single glass thickness

A2.2 Assumptions

The normal stresses in the section of the structural sealant have a uniform distribution

$$\tau_{des} = X_{des}$$

A2.3 Supported kits

A2.3.1 Determination of bite h_c

The stress at the centre of the longest side of the pane can be calculated as follows:

$$\tau_{centre} = a \cdot W/2 \cdot h_c \cdot E \cdot h_c \cdot \left[a \cdot W/2 \cdot \tau_{des} \right]$$

$(h_c \text{ limits, see clause 5.1.4.7})$

A2.3.2 Determination of the thickness e

The thickness of the structural sealant is related to the design shear stress Γ_{des} (Pa) of the silicone

$$e = (G \times U) / (X_{des})$$

$e \geq 6 \text{ mm}$ is advisable

Value of Δ

$b > a$ the pane is supported at side a



$$\Delta = [(T_c - T_0) \cdot r_c - (T_v - T_0) \cdot r_v] \cdot \sqrt{(a/2)^2 + b^2}$$

$b > a$ the pane is supported at side b



$$\Delta = [(T_c - T_0) \cdot r_c - (T_v - T_0) \cdot r_v] \cdot \sqrt{a^2 + (b/2)^2}$$

with typical values:

- $T_c = 55^\circ\text{C}$
- $T_v = 80^\circ\text{C}$, see also clause 4.4.4.1

- $T_0 = 20^\circ\text{C}$
- $r_c = 24 \cdot 10^{-6} / \text{K}$ for aluminium; $= 12 \cdot 10^{-6} / \text{K}$ for steel
- $r_v = 9 \cdot 10^{-6} / \text{K}$ for glass

A2.3.3 Relation between h_c and e

Given the present state of knowledge, it is advisable to respect the following relationship:

$$e \leq h_c \leq 3e$$

A2.3.4 Calculation of the hermetic seal of the insulating unit working as a structural sealant

$$r \geq \frac{S \times a \times W}{2 \times \dagger_{des}}$$

$$r \geq 6 \text{ mm}$$

β is the part of the wind load carried by the outer glass component

- if $d_1 \leq d_2 \rightarrow \beta \simeq 1/2$, then $\beta \equiv 1/2$
- if $d_1 > d_2 \rightarrow \beta > 1/2$, then $\beta = 1$

For small units or non-rectangular shapes, climatic effects shall be taken into account.

A2.4 Unsupported kits

A2.4.1 Determination of the thickness e

The thickness of the structural sealant is related to the design shear stress Γ_{des} (Pa) of the silicone

$$e = \lceil (G \times \Delta) / (\Gamma_{des}) \rceil$$

$$e \geq 6 \text{ mm is advisable}$$

$$\Delta = [(T_c - T_0) \cdot r_c - (T_v - T_0) \cdot r_v] \cdot \sqrt{(a/2)^2 + (b/2)^2}$$

A2.4.2 Value of Δ

with typical values:

- $T_c = 55^\circ\text{C}$
- $T_v = 80^\circ\text{C}$, see also 4.4.5.1
- $T_0 = 20^\circ\text{C}$
- $\alpha_c = 24 \cdot 10^{-6} / \text{K}$ for aluminium; $= 12 \cdot 10^{-6} / \text{K}$ for steel
- $\alpha_v = 9 \cdot 10^{-6} / \text{K}$ for glass

A2.4.3 Bearing capacity under permanent shear loading

The glazing self-weight is considered to be supported along the glazing height h_v .

$$h_c \geq \frac{P}{2 \cdot \Gamma_{\infty} \cdot h_v}$$

$$h_v = a \text{ or } b$$

It is always necessary to verify that: $h_c \geq \lceil a \times W/2 \dagger_{des} \rceil$

Given the present state of knowledge, it is advisable to respect the following relationship:

$$e \approx h_c \approx 3e$$

ANNEX 3 - Reference documents

(+) 1 – EN ISO 11600:2002 Building construction - Jointing products - Classification and requirements for sealants.....	24
(+) 2 - EN 12365:2003 Building hardware - Gasket and weatherstripping for doors, windows, shutters and curtain walling	24
(+) 3 - EN 1279 Insulating glass units - Part 1: Generalities and dimensional tolerances.....	26
(+) 4 EN 13501-1:2011 - Fire classification of construction products and building elements Part 1: Classification using data from reaction to fire tests	27
(+) 5 EN 13823:2010 - Reaction to fire tests for building products. Building products excluding floorings exposed to the thermal attack by a single burning item.....	27
(+) 6 EN 13501-2:2007 - Fire classification of construction products and building elements Part 2: Classification using data from fire resistance tests, excluding ventilation services.....	27
(+) 7 EN 1364-3:2006 - Fire resistance tests for non-loadbearing elements. Curtain walling. Full configuration (complete assembly) ...	27
(+) 8 EN 1364-4:2007 - Fire resistance tests for non-loadbearing elements. Curtain walling. Part configuration	27
(+) 9 TS 1187: 2012 - Test methods for external fire exposure to roofs	27
(+) 10 - UEAtc Guideline: "Technical Guide for the Approval of Structural Sealant Glazing systems"	28
(+) 11 - EN 12153:2000 — Curtain walling — Air permeability — Test method or	29
(+) 12 - EN 1026:2000 - Windows and door – Air permeability – Test method.....	29
(+) 13 - EN 12155:2000 - Curtain walling — Watertightness — Laboratory test under static pressure	29
(+) 14 - EN 1027:2000- Windows and door – Watertightness – Test method.....	30
(+) 15 - EN 13830:2003 Curtain walling - Product standard.....	30
(+) 16 EN 28339:1991 - Building construction. Jointing products. Sealants. Determination of tensile properties.....	32
(+) 17 - ISO 4892-2:1994 - Methods of exposure to laboratory light sources - Part 2 Xenon-arc source	34
(+) 18 - ISO 9227:1990 - Corrosion test in artificial atmosphere - Salt spray test.....	36
(+) 19 - ISO 3231:1993 - Determination of resistance to humid atmospheres containing sulphur dioxide	36
(+) 20 - EN 14609: Windows – Determination of the resistance to static torsion.	42
(+) 21 - EN 14608: Windows – Determination of the resistance to racking.....	42
(+) 22 - EN 1191 – Windows and doors - Resistance to repeated opening and closing – Test method.....	42
(+) 23 - EN 13049:2003 Window – Soft and heavy body impact – Test method – Safety requirement and classification	42
(+) 24 - EN 14019 Curtain walling – Impact resistance – Performance requirement	42
(+) 25 - EN 27389 / ISO 7389:2002 Building construction - Jointing products - Determination of elastic recovery of sealants.....	43
(+) 26 - ISO 10563:1991 Building construction -- Sealants for joints -- Determination of change in mass and volume	43
(+) 27 - EN ISO 527-3:1995 Plastics - Determination of tensile properties - Part 3: Test conditions for films and sheets	45
(+) 28 - EN 12179:2000 - Curtain walling - Resistance to wind load - Test method or.....	47
(+) 29 - EN 12211:2000 - Windows and doors - Resistance to wind load - Test method.....	47
(+) 30 - EN ISO 140-3: 1998 Acoustics - Measurement of sound insulation in buildings and of building elements - Part 3: Laboratory measurements of airborne sound insulation of facade elements and facades (ISO 140-3:1998) and by classifying them in accordance with EN ISO 717-1.	48
(+) 31 - EN ISO 12567-1:2000 - Thermal performance of windows and doors - Determination of the thermal transmittance by hot box: method - Part 1: Complete windows and door.....	48
(+) 32 EN ISO 12567-2: 2006 - Thermal performance of windows and doors - Determination of thermal transmittance by hot box method - Part 2: Roof windows and other projecting windows.....	48
(+) 33 - ISO 8990:1994 - Thermal insulation -- Determination of steady-state thermal transmission properties - Calibrated and guarded hot box (This standard is general and can be used for windows and facade)	48
(+) 34 - EN 12412-2:2003 - Thermal performance of windows, doors and shutters - Determination of thermal transmittance by hot box method - Part 2: Frames	48
(+) 35 - EN 10077-2:2003 - Thermal performance of windows, doors and shutters - Calculation of thermal transmission - Part 2 - Numerical method for frame.....	48
(+) 36 - EN ISO 10211 - Thermal bridges in building construction - Heat flow surface temperature - Detailed calculations.....	48
(+) 37 EN 13947: Thermal performance of curtain walling - Calculation of thermal transmittance.....	48
(+) 38 EN ISO 13789: Thermal performance of buildings - Transmission and ventilation heat transfer coefficients - Calculation method.....	48
(+) 39 - EN ISO 13788:2001 - Hydrothermal performance of building components and building elements - Internal surface temperature to avoid critical surface humidity and interstitial condensation - Calculation methods - Annex D.....	48
(+) 40 - ISO 1183-1:2004 Plastics -- Methods for determining the density of non-cellular plastics -- Part 1: Immersion method, liquid pycnometer method and titration method	49
(+) 41 - ISO 868:2003 Plastics and ebonite -- Determination of indentation hardness by means of a durometer (Shore hardness)	49
(+) 42 - ISO 7111:1987 - Thermogravimetry of polymers - Temperature scanning method.....	49
(+) 43 - ISO 7724-1:1984 - Paints and varnishes -- Colorimetry -- Part 1: Principles	49
(+) 44 - ISO 7724-2:1984 - Paints and varnishes -- Colorimetry -- Part 2: Colour measurement.....	49
(+) 45 - ISO 7724-3:1984 - Paints and varnishes -- Colorimetry -- Part 3: Calculation of colour differences.....	49

(+) 46 - ISO 4660:1999 - Rubber, raw natural - Colour index test.....	49
(+) 47 - EN 573-3:2003 - Aluminium and aluminium alloys - Chemical composition and form of wrought product - Part 3: Chemical composition.....	50
(+) 48 - EN 515:1993 - Aluminium and aluminium alloys - Wrought product - Temper designation.....	50
(+) 49 - Specification for the quality sign for anodic oxidation coatings on wrought aluminium for architectural purposes - QUALANOD / EURAS - EWAA / European Aluminium Anodisers Association.....	50
(+) 50 - EN ISO 2360:2003 Non-conductive coatings on non-magnetic electrically conductive basis materials - Measurement of coating thickness - Amplitude-sensitive eddy current method.....	50
(+) 51 - EN 12373-3 - Aluminium alloy - Anodising - Part 3 - Determination of the thickness of anodic oxidation coating - Non-destructive measurement by split-beam microscope.....	50
(+) 52 - ISO 1463:2003 Metallic and oxide coatings - Measurement of coating thickness - Microscopical method.....	50
(+) 53 - EN 12373-2: 1999 - Aluminium alloy - Anodising - Part 2 - Determination of the mass per unit area (surface density) of anodic oxidation coating - Gravimetric method.....	50
(+) 54 - EN 12373-4 - Aluminium alloy - Anodising - Part 4 - Estimation of the loss of absorptive power of anodic oxidation coating after sealing by a spot test with prior acid treatment.....	50
(+) 55 - EN 12373-6 - Aluminium alloy - Anodising - Part 6 - Assessment of the quality of a sealed anodic oxidation coating by measurement of loss of mass after immersion in phosphoric acid/chromic acid solution without prior acid treatment.....	50
(+) 56 - EN 12373-5 - Assessment of the quality of a sealed anodic oxidation coating by measurement of admittance.....	50
(+) 57 - EN 12150-1:2000 - Thermally toughened soda lime silicate safety glass - Part 1: Definition and description.....	51
(+) 58 - EN 1863-1:2000 - Heat strengthened soda lime silicate glass - Part 1: Definition and description.....	51
(+) 59 - EN 12543-2:1999 - Laminated glass and laminated safety glass part 2: Laminated safety glass.....	51
(+) 60 - EN 1096-1:1999 - Glass in building - Coated glass - Part 1: Definitions and classification.....	52
(+) 61 - EN 1096-2:2001 - 2001 - Glass in building - Coated glass - Part 2: Requirements and test methods for class A, B and S coatings.....	52
(+) 62 - EN 1096-1:1999 - Glass in building - Coated glass - Part 4: Evaluation of conformity.....	53
(+) 63 - EN 572-2 Basic soda lime silicate glass products - Part 2: Float glass.....	53
(+) 64 - EN 10088-1:1995 - Stainless steels - Part 1: List of stainless steels.....	53
(+) 65 - EN 10088-2:1995 - Stainless steels - Part 2: Technical delivery conditions for sheet/plate and strip for general purposes.....	53
(+) 66 - EN 10088-3:1995 - Stainless steels - Part 3: Technical delivery conditions for semi-finished products, bars, rods and sections for general purposes.....	53
(+) 67 - ISO 3207:1975 Statistical interpretation of data -- Determination of a statistical tolerance interval -.....	56
(+) 68 - EN 12154:2000 Curtain walling - Watertightness - Performance requirements and classification.....	58
(+) 69 - EN 12152:2000 Curtain walling - Air permeability - Performance requirements and classification.....	58
(+) 70 - EN 12207:2000 Windows and doors - Air permeability - Classification.....	58
(+) 71 - EN 12208:2000 Windows and doors - Watertightness - Classification.....	58
(+) 72 - EN 13115:2001: Windows: - Classification of mechanical properties - Racking, torsion and operating forces.....	62
(+) 73 - EN 12210:2000 - Windows and doors - Resistance to wind load.....	62
(+) 74 - EN 13116:2001 - Curtain walling - Resistance to wind load - Performance requirements.....	62
(+) 75 - EN ISO 717-1:1997: Acoustics - Rating of sound insulation in buildings and of building elements - Part 1: Airborne sound insulation (ISO 717-1:1996).....	62
(+) 76 - ISO 9001:2000: Quality management systems - Requirements.....	70
(+) 77 EN 1279-6:2002 - Glass in building. Insulating glass units. Factory production control and periodic tests.....	74

ANNEX 4 - SSGK - Testing sequence

