

ETAG 006

GUIDELINE FOR EUROPEAN TECHNICAL APPROVAL SYSTEMS OF MECHANICALLY FASTENED FLEXIBLE ROOF WATERPROOFING MEMBRANES

Table of Contents

FOREWORD

Section One: INTRODUCTION

1. PRELIMINARIES
2. SCOPE
3. TERMINOLOGY

Section Two: GUIDANCE FOR THE ASSESSMENT OF THE FITNESS FOR USE

GENERAL NOTES

4. REQUIREMENTS
5. METHODS OF VERIFICATION
6. ASSESSING AND JUDGING OF THE FITNESS FOR USE OF PRODUCTS FOR AN INTENDED USE
7. ASSUMPTIONS AND RECOMMENDATIONS under which the fitness for use of the products is assessed

Section Three: ATTESTATION OF CONFORMITY (AC)

8. ATTESTATION AND EVALUATION OF CONFORMITY

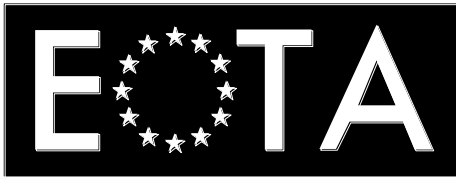

European Organisation for Technical Approvals
Europäische Organisation für Technische Zulassungen
Organisation Européenne pour l'Agrément Technique

red. Anm. Derzeit nur in englischer Fassung verfügbar

ETAG 006

Edition March 2000
Amended November 2012

GUIDELINE FOR EUROPEAN TECHNICAL APPROVAL
OF
SYSTEMS OF MECHANICALLY FASTENED
FLEXIBLE ROOF WATERPROOFING MEMBRANES

EOTA
Kunstlaan 40 Avenue des Arts,
B - 1040 Brussels

Table of Contents

FOREWORD.....	7
Section One: INTRODUCTION.....	8
1. PRELIMINARIES	8
1.1 Legal basis	8
1.2 Status of ETA-guidelines	8
2. SCOPE	8
2.1 Scope.....	8
2.2 Use categories, product families, systems	10
3. TERMINOLOGY	12
3.1 Common terminology and abbreviations	12
3.2 Particular terminology and abbreviations.....	12
Section Two: GUIDANCE FOR THE ASSESSMENT OF THE FITNESS FOR USE	15
GENERAL NOTES	15
4. REQUIREMENTS.....	17
4.1 Mechanical resistance and stability:.....	18
4.2 Safety in case of fire:.....	18
Reaction to fire / External fire performance	18
4.3 Hygiene, health and the environment.....	18
Indoor environment: Dampness.....	19
Outdoor environment	19
4.4 Safety in use.....	19
Slipperiness.....	20
Mechanical resistance and stability.....	20
4.5 Protection against noise	20
4.6 Energy economy and heat retention	20
4.7 Related aspects of serviceability	21
Dimensional stability.....	21
Resistance to deterioration	21
Physical agents	21
Chemical agents	21
5. METHODS OF VERIFICATION.....	22
5.1 System	23
5.1.2 Safety in case of fire.....	23
5.1.2.1 Reaction to fire / External fire performance	23
5.1.3 Hygiene, health and the environment.....	23
5.1.3.1 Content and /or release of dangerous substances	23
5.1.4 Safety in use.....	24
5.1.4.1 Wind uplift test.....	24
Concept of full scale and small scale testing	24
5.1.5 Protection against noise	32
5.1.6 Energy economy and heat retention	32
5.1.7 Aspects of durability, serviceability and identification.....	32
5.2 Components/membrane	32
5.2.1 Mechanical resistance and stability.....	32
5.2.2 Safety in case of fire.....	32
5.2.2.1 Testing of reaction to fire.....	32
5.2.3 Hygiene, health and the environment.....	33
5.2.3.1 Testing of peel resistance of joints.....	34
5.2.3.2 Testing of shear resistance of joints	35
5.2.3.3 Resistance to tear	35
5.2.3.4 Resistance to cold bending	35
5.2.3.5 Testing of resistance to water pressure	35

5.2.3.6	Determination of water vapour permeability	35
5.2.3.7	Determination of tensile properties	35
5.2.3.8	Testing of resistance to static loading and impact loading.....	35
5.2.3.9	Dimensional stability.....	35
5.2.3.10	Thickness	35
5.2.3.11	Flow resistance	36
5.2.4	Safety in use.....	36
5.2.4.1	Slipperiness.....	36
5.2.5	Protection against noise	36
5.2.6	Energy economy and heat retention	36
5.2.7	Related aspects of durability, serviceability and identification.....	36
5.2.7.1	Testing of peel resistance after long term exposure to heat and water	36
5.2.7.2	Testing of shear resistance after long term exposure to heat.....	37
5.2.7.3	Resistance to cold bending/folding after long term exposure to heat, UV and ozone.....	37
5.3	Components/mechanical fastenings	37
5.3.1	Mechanical resistance and stability	37
5.3.2	Safety in case of fire.....	37
5.3.3	Hygiene, health and the environment.....	38
5.3.4	Safety in use.....	38
5.3.5	Protection against noise	38
5.3.6	Energy economy and heat retention	38
5.3.7	Related aspects of durability, serviceability and identification.....	38
5.4	Components/insulation	39
5.4.1	Mechanical resistance and stability	39
5.4.2	Safety in case of fire.....	39
5.4.3	Hygiene, health and the environment.....	39
5.4.3.1	Compressibility test for insulation materials	39
5.4.4	Safety in use.....	39
5.4.5	Protection against noise	39
5.4.6	Energy economy and heat retention	40
5.4.6.1	Calculation or testing of thermal transmission	40
5.4.7	Related aspects of durability, serviceability and identification.....	40
6.	ASSESSING AND JUDGING OF THE FITNESS FOR USE of products for an intended use	41
6.1	System	42
6.1.1	Mechanical resistance and stability.....	42
6.1.2	Safety in case of fire.....	42
6.1.2.1	External fire performance.....	42
6.1.3	Hygiene, health and the environment.....	42
6.1.3.1	Content and /or release of dangerous substances	42
6.1.4	Safety in use.....	43
6.1.4.1	Resistance to wind uplift.....	43
6.1.5	Protection against noise	43
6.1.6	Energy consumption and heat retention.....	43
6.1.7	Aspects of durability, serviceability and identification.....	43
6.2	Components/membrane	43
6.2.1	Mechanical resistance and stability	43
6.2.2	Safety in case of fire.....	43
6.2.2.1	Reaction to fire	43
6.2.3	Hygiene, health and the environment.....	43
6.2.3.1	Peel resistance of joints	43
6.2.3.2	Shear resistance of joints	43
6.2.3.3	Tear resistance	43
6.2.3.4	Resistance to cold bending	43
6.2.3.5	Resistance to water pressure.....	43
6.2.3.6	Water vapour permeability	44
6.2.3.7	Tensile properties.....	44
6.2.3.8	Resistance to static loading and impact loading	44
6.2.3.9	Dimensional stability.....	44
6.2.3.10	Thickness	44
6.2.3.11	Flow resistance	44

6.2.4	Safety in use.....	44
6.2.4.1	Slipperiness.....	44
6.2.5	Protection against noise.....	44
6.2.6	Energy consumption and heat retention.....	44
6.2.7	Related aspects of durability, serviceability and identification.....	44
6.2.7.1	Peel resistance after long term exposure to heat and water.....	44
6.2.7.2	Shear resistance after long term exposure to heat.....	44
6.2.7.3	Resistance to cold bending/folding after long term exposure to heat, UV and ozone.....	45
6.3	Components/mechanical fasteners	45
6.3.1	Mechanical resistance and stability.....	45
6.3.2	Safety in case of fire.....	45
6.3.3	Hygiene, health and the environment.....	45
6.3.4	Safety in use.....	45
6.3.5	Protection against noise.....	45
6.3.6	Energy consumption and heat retention.....	45
6.3.7	Related aspects of durability, serviceability and identification.....	45
6.4	Components/insulation	46
6.4.1	Mechanical resistance and stability.....	46
6.4.2	Safety in case of fire.....	46
6.4.2.1	Reaction to fire.....	46
6.4.3	Hygiene, health and the environment.....	46
6.4.3.1	Compressibility test for insulation materials.....	46
6.4.4	Safety in use.....	46
6.4.5	Protection against noise.....	46
6.4.6	Energy economy and heat retention.....	46
6.4.6.1	Thermal resistance.....	46
6.4.7	Related aspects of durability, serviceability and identification.....	46
6.8	Identification of the product.....	46
7.	ASSUMPTIONS AND RECOMMENDATIONS under which the fitness for use	
	of the products is assessed	48
7.1	Design and execution of Systems of mechanically fastened flexible roof	
	waterproofing membranes into the works.....	48
7.2	Packaging, transport and storage.....	49
7.3	Execution of works.....	49
7.4	Maintenance and repair.....	50
	Section Three: ATTESTATION OF CONFORMITY	51
8.	ATTESTATION AND EVALUATION OF CONFORMITY	51
8.1	EC-Decisions.....	51
8.2	Responsibilities.....	51
8.2.1	Task of the manufacturer covering the factory production control.....	51
8.2.1.1	Factory production control.....	51
8.2.1.2	Declaration of conformity.....	51
8.2.2	Task of the manufacturer covering the product.....	51
8.2.2.1	Initial type testing.....	51
8.2.3	Tasks of the approved body.....	51
8.2.3.1	Assessment of the factory production control - initial inspection	
	and continuous surveillance.....	51
8.2.3.2	Certification of factory production control.....	52
8.3	Documentation.....	52
8.4	EC marking and information.....	53
	Section Four: ETA CONTENT	54
9.	THE ETA CONTENT	54
9.1	The ETA content.....	54
9.2	Additional information.....	56
Annex A	List of reference documents.....	57

Annex B	Common terminology and abbreviations	61
Annex C	Site pullout test	65
Annex D	Procedure for issue of ETA's for fasteners	67

FOREWORD

Background of the subject

This Guideline has been drawn up by the EOTA Working Group 04.02/02 Systems of mechanically fastened flexible roof waterproofing membranes.

The WG consisted of members from 11 EU-countries (Denmark (Convenor), Sweden, Belgium, Finland, France, Germany, Netherlands, Italy, Portugal, Spain and the United Kingdom), one EFTA-country (Norway), two observers (Hungary and Poland) and three European industrial organisations (IFD - International Federation of Roofing Contractors, CEO - European Tool Committee and ESWA - European Synthetic Waterproofing Association). Representatives of European fastener manufacturers attended the meetings as invited experts. In the absence of an official European trade organisation representatives of the European fastener manufacturers have formed a European Fastener Group with the purpose of providing technical input for the elaboration of this Guideline.

It is important to distinguish between EOTA- and CEN-involvement in the area of Systems of mechanically fastened flexible roof waterproofing membranes. EOTA deals with the combined system of membrane and fastening as described in the scope of this Guideline, whilst CEN deals with membranes in general. As it appears from the Guideline, existing CEN test methods are used as far as possible.

The Guideline sets out the performance requirements for Systems of mechanically fastened flexible roof waterproofing membranes, the verification methods used to examine the various aspects of performance, the assessment criteria used to judge the performance for the intended use and the presumed conditions for the design and execution.

The general assessment approach of the Guideline is based on relevant existing knowledge and testing experience.

The UEAtc Supplementary guide for the assessment of mechanically fastened roof waterproofing (April 1991) has formed the basis for the Guideline.

Reference documents

Reference documents are referred to within the body of the EOTA and are subject to the specific conditions mentioned therein.

The **list of reference documents** for this ETAG is given in Annex A. When additional parts for this ETAG are written afterwards, they may comprise modifications to the list of reference documents applicable to that part.

EOTA comprehension documents will permanently take on board all useful information on the updating of reference documents and on general understanding of this ETAG as developed when delivering ETA's in consensus by the EOTA members.

EOTA technical reports go into detail in some aspects and as such are not part of the ETAG but express the common understanding of existing knowledge and experience of the EOTA bodies at that moment. When knowledge and experience is developing, especially through approval work, these reports can be amended and supplemented. When this happens, the effect of the changes upon the ETAG will be determined by EOTA and laid down in the relevant comprehension document.

Section One: INTRODUCTION

1. PRELIMINARIES

1.1 LEGAL BASIS

This ETAG has been established in compliance with the provisions of the Council Directive 89/106/EEC (CPD) and has been established taking into account the following steps:

- the final mandate issued by the EC : 25 June 1997
- the final mandate issued by the EFTA : 25 June 1997
- adoption of the Guideline by the Executive Commission of EOTA : 13 October 1999
- opinion of the Standing Committee for Construction : 9-10 December 1999
- endorsement by the EC : 18 August 2000

This document is published by the Member States in their official language or languages according to art. 11.3 of the CPD.

ETAG 006 edition March 2000 is superseded.

1.2 STATUS OF GUIDELINES

1.2.1 An ETA is one of two types of technical specifications in the sense of the EC Construction Products Directive (89/106/EEC), that means that Member States shall presume the approved products fit for their intended use, i.e. that they enable works in which they are employed to satisfy the essential requirements during an economically reasonable working life, provided that:

- the works are properly designed and built
- the conformity of the products with the ETA has been properly attested.

1.2.2 An ETA-Guideline is a basis for ETAs, that is a basis for technical assessment of the fitness for use for an intended use¹.

ETA-Guidelines express the common understanding of the approved bodies of the provisions of the EC Construction Products Directive and of the Interpretative Documents with regard to the products and uses concerned established within the framework of a mandate given by the EC-Commission after consulting the EC-Standing Committee for Construction.

1.2.3 ETA-Guidelines are binding for the issuing of ETAs of the products concerned for an intended use when accepted by the EC-Commission after consultation with the EC-Standing Committee for Construction and published by the Member States.

The applicability and the satisfaction of an ETA-Guideline for a product and its intended use have to be assessed in a case by case evaluation by an authorised approval body.

Satisfaction of the provisions of an ETA-Guideline (examinations, tests and evaluations) leads to a presumption of fitness for use only through this case by case evaluation.

Products which are outside of the scope of an ETA-Guideline may be considered where appropriate through the approved procedure without guidelines according to art. 9.2 of the CPD.

The requirements in ETA-Guidelines are set out in terms of objectives and of relevant actions to be taken into account. ETA-Guidelines specify values and characteristics, the conformity with which the presumption that the requirements set out are satisfied whenever the state of the art permits to do so. The ETA-Guidelines may indicate alternative possibilities for the demonstration of the satisfaction of the requirements.

2. SCOPE

2.1 SCOPE

¹An ETA-Guideline is not in itself a technical specification in the sense of the CPD.

Kits of mechanically fastened flexible roof waterproofing membranes.

The system consists of single or multi-layer waterproof coverings connected to the load-bearing structure by point or linear fasteners. Furthermore, the system may include the insulation material as an integrated part of the system.

The waterproof coverings are limited to continuous watertight kits based on flexible sheets made of e.g. polymeric, bituminous or rubber materials and manufactured in the factory.

The fasteners are made of either metal and/or plastics.

The load-bearing structures can be made from e.g. metal, concrete or timber.

Kits consisting of bituminous sheets or polymeric and rubber sheets on timber structures fastened by clout nails are **outside** the scope of this Guideline

The guideline does not assess the whole roof, but in assessing the waterproofing system account has to be taken to those elements of the roof structure that may affect the performance of the waterproofing system.

In the context of this ETAG the kits are considered to be the product

Figure 1 gives examples of mechanically fastened roof waterproofing membranes. The listed range of examples is non-exhaustive:

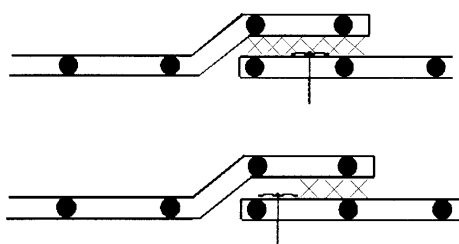

a: Fastenings at seams:
Linear individual fastening in area of overlapping at edge of roofing

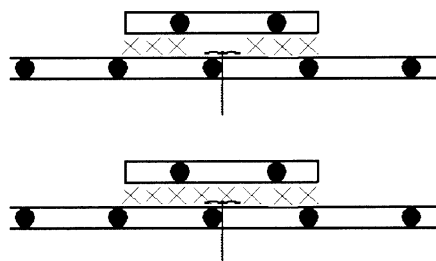

b: Non self-sealing fastening in the plane of the roof.
Individual fastening, independent of seams, penetrating the roofing and covered with plates or strips of roofing material welded thereon

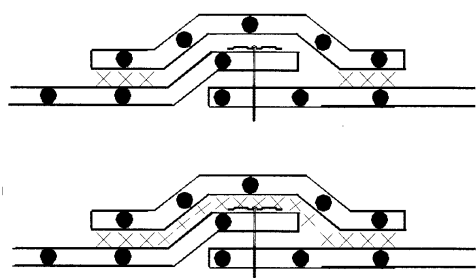

c: Covered fastenings at seams.
Linear individual fastening of overlapping edges of roofing with welded-on strips of roofing

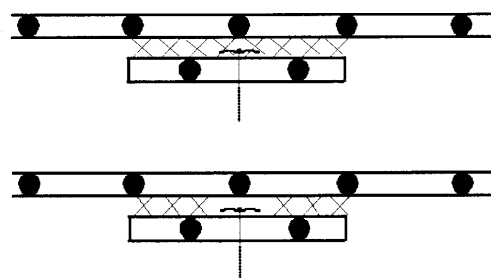

d: Fastening at underside.
Plates or strips of roofing material or composite sheet metal fixed by means of individual fastenings and covered with roof waterproofing bonded or welded thereon

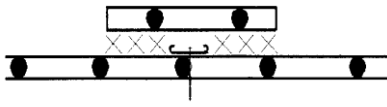

e: Linear fastening bars
Linear fastenings using profiles covered with strips of roofing welded thereon

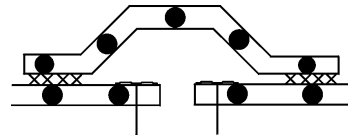

f: Covered fastenings at seams
Joint realised by end to end position of the membranes fixed on both sides and covered with a welded overlap strip

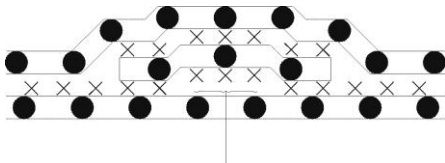

g. Fastening in under layer
Two layer system with fully fastened under layer and top layer, which is torched or adhered to the under layer (normally bituminous)

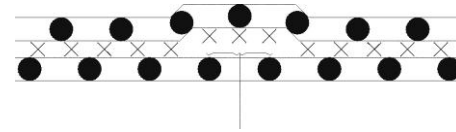

h. Fastening in under layer
Two layer system with fully fastened under layer and top layer, which is torched or adhered to the under layer (normally bituminous)

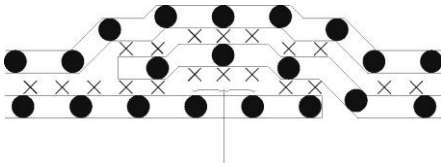

i. Fastening in under layer
Two layer system with fully fastened under layer and top layer, which is torched or adhered to the under layer (normally bituminous)

Key to the examples:

xxxxx = bond, welding

 = flexible membranes

Figure 1. Examples of mechanically fastened roof waterproofing membranes

The examples shown above are all examples of kits with flexible membranes. The examples where the joint is fully welded are kits with bituminous, rubber or polymeric membranes with adhered joints. The examples with welded seams are bituminous membranes (hot air) or polymeric membranes (hot air or chemicals).

Two fasteners at spacings less than or equal to 120 mm in the same top flange are regarded as one fastener.

2.2 USE CATEGORIES, PRODUCT FAMILIES, SYSTEMS/KITS, COMPONENTS

In accordance with EC Guidance Paper C, ETA's for kits or components of kits of mechanically fastened flexible roof waterproofing membranes may be issued for one (or more), of the following situations. In

situations (ii) and (iii) the ETA(s) shall be based on testing and assessment of the entire kit and on consent between the ETA holder and all the component suppliers.

Kit approval:

i) The whole kit, including membrane, fastener and (sometimes) insulation, is marketed and supplied by the ETA holder who takes full responsibility for it.

ii) As i) above, except that the components, which are specified in the ETA may be obtained, from other suppliers, in separate transactions.

Fastener Approval:

iii) The fastener is marketed separately, with an individual ETA.

3. TERMINOLOGY

3.1 COMMON TERMINOLOGY AND ABBREVIATIONS

See Annex B

3.2 PARTICULAR TERMINOLOGY AND ABBREVIATIONS related to Kits of mechanically fastened flexible roof waterproofing membranes.

3.2.1 Axial fastener failure

Equal to the pull out of a fastener, or failure of a fastener in the direction perpendicular to the surface

3.2.2 Component

A defined constituent part of a kit.

3.2.3 Declared value

Value declared according to the relevant product standard or to this Guideline.

3.2.4 Fastener

A fastener can be made of a washer, a metal sleeve and a screw or of a plastic washer with an integrated sleeve and a metal shank. The sketch below is an example of a fastener **for terminology purposes only**.

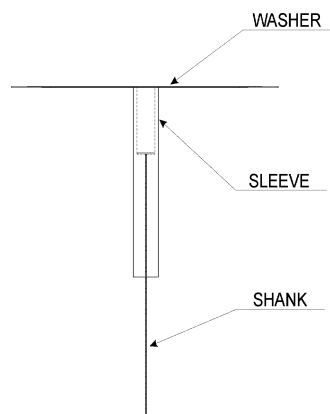

3.2.5 Fastening system

An assembly of components intended to secure a waterproofing system to the load-bearing structure by means of point fasteners or linear fasteners. Whilst primarily intended to secure the covering against wind uplift forces, the system may contribute to securing intermediate layers such as thermal insulation, or a vapour control layer.

3.2.6 Insulating material

A pre-fabricated product with a high thermal resistance which is intended to impart insulating properties to the substrate to which it is applied.

3.2.7 Jointing technique

Sealing of at least two layers of waterproofing membranes, e.g. bond (torch, adhesive) or welding (hot air, chemicals).

3.2.8 Linear fastener

Commonly a continuous strip or lath of metal or other material perforated by point fasteners intended to secure the waterproof covering in the general area of the roof and/or at its perimeter.

3.2.9 Loads

Admissible (design) load (W_{adm}) = the load per fastener derived from the test load

Test load (W_{test}) = maximum load in the cycle preceding the failure cycle measured in the wind uplift test (see 5.1.4.1)

Corrected load ($W_{corr.}$) = test load modified by correction factors (see 5.1.4.1)

3.2.10 MEFAWAME (CEC abbreviation)

Kits of mechanically fastened flexible roof waterproofing membranes.

3.2.11 Point fastener

Commonly a shaft, in the form of a screw, nail or expanding anchor, together with a disc-shaped washer or collar. Forces may be transmitted to the fastener by the clamping action of the washer or by bond between a plastic surface on the washer and a plastic roof covering, or by other means.

3.2.12 Powder actuated fastener

Fastener which is shot fired into the substrate

3.2.13 Roof

The structural deck and all the layers on it, including the surface that is exposed to the weather and including the necessary details.

3.2.14 Sample

A representative part of a waterproofing system as a final product or its components for the purpose of identification and/or verification of its characteristics.

3.2.15 Structural deck

The part of the roof that, as a construction element, has to transfer both permanent and variable loads to the other parts of the building.

3.2.16 Supporting layer

A layer of material which forms the base of a final product

3.2.17 Test load

Load determined from the various test methods.

3.2.18 Test specimen

A part of a sample taken as defined by a specific method of verification and/or test method.

3.2.19 Unwinding

The turning or rocking motion of the screw which makes it withdraw from the substrate

3.2.20 Vapour control layer

A layer of material used to limit the transportation of water vapour into or through any part of the works.

3.2.21 Waterproofing

The act preventing the passage of water from one plane to another.

3.2.22 Waterproofing system

A particular combination of a defined set of components, such as one or more waterproofing sheets or welding materials installed in the works by application and/or incorporation and/or assembly of the components in conformity with particular design methods and/or particular execution methods to form a watertight layer on top of the roof.

Section Two: GUIDANCE FOR THE ASSESSMENT OF THE FITNESS FOR USE

GENERAL NOTES

a) Applicability of the ETAG

This ETAG provides guidance on the assessment of a family of Systems of mechanically fastened flexible roof waterproofing membranes (MEFAWAME) and their intended uses. It is the manufacturer or producer who defines the kit for which he is seeking an ETA and how it is to be used in the works, and consequently the scale of the assessment.

Annex D of this ETAG additionally provides the basis for assessment of fasteners for mechanically fixing of roofing sheets with the purpose of issuing component ETA's for the fasteners.

b) General lay out of this section

The assessment of the fitness of MEFAWAME with regard to their fitness for intended use in construction works is a process with four (highlighted in bold below) main steps:

- Chapter 4 clarifies the **specific requirements for the works** relevant to the MEFAWAME and uses concerned, beginning with the Essential Requirements for works (CPD art. 11.2) and then listing the corresponding relevant characteristics of the MEFAWAME
- Chapter 5 extends the list in chapter 4 into more precise definitions and **the methods available to verify** product characteristics and to indicate how the requirements and the relevant product characteristics are described. This is done by test procedures, methods of calculation and of proof, etc
- Chapter 6 provides guidance on the **assessing and judging methods** to confirm fitness for the intended use of the MEFAWAME
- Chapter 7, **assumptions and recommendations** are only relevant in as far as they concern the basis upon which the assessment of the MEFAWAME is made concerning the fitness for the intended use

c) Levels or classes related to the Essential Requirements and to the product performance (see ID clause 1.2 and EC Guidance Paper E)

According to the CPD, "Classes" in this ETAG refer only to mandatory levels or classes laid down in the EC-mandate.

This ETAG indicates however the compulsory way of expressing relevant performance characteristics for the MEFAWAME. If, for some uses at least one Member State has no regulations, a manufacturer always has the right to opt out of one or more of them, in which case the ETA will state "no performance determined" against that aspect, except for those properties for which, when no determination has been made, the MEFAWAME does not any longer fall under the scope of this Guideline.

d) Working life (durability) and serviceability

The provisions, test and assessment methods in this ETAG or referred to have been written based on the assumption that the estimated working life of the product for the intended use is at least 10 years, provided that the product is subjected to normal use and maintenance. These provisions are based upon the current state of art and the available knowledge and experience.

An "assumed intended working life" means that it is expected that, when an assessment following the ETAG provisions is made, and when this working life has elapsed, the real working life may be, in normal use conditions, considerably longer without major degradation affecting the Essential Requirements.

The indication given as to the working life of a product cannot be interpreted as a guarantee given by the producer or the approval body. They shall be regarded as a means for the specifiers to choose the appropriate criteria for products in relation to the expected economically reasonable working life of the works (based upon ID. par. 5.2.2).

Many systems may have a working life well in excess of 10 years but higher working lives are not part of the assessments in this ETAG. Claims for longer working lives shall be verified independently by a special procedure according to the Construction Products Directive art. 9.2.

e) Fitness for the intended use

According to the CPD it has to be understood that within the terms of this ETAG, products shall “have such characteristics that the works in which they are to be incorporated, assembled, applied or installed, can if properly designed and built, satisfy the Essential Requirements” (CPD art. 2.1)

Hence, the MEFAWAME shall be suitable for use in construction works which (as a whole and in their separate parts) are fit for their intended use, account being taken of economy, and in order to satisfy the Essential Requirements. Such requirements shall, subject to normal maintenance, be satisfied for an economically reasonable working life. The requirements generally concern actions which are foreseeable (CPD, Annex I, preamble).

4. REQUIREMENTS

4.0 General

This chapter sets out the aspects of performance to be examined in order to satisfy the relevant Essential Requirements for Systems for mechanically fastened flexible roof waterproofing membranes, by:

- expressing in more detail, within the scope of the Guideline, the relevant Essential Requirements of the CPD, in the Interpretative Documents and in the mandate, for works or parts of the works, taking into account the actions to be considered, as well as the expected durability and serviceability of the works
- applying them to the scope of the Guideline (product and where appropriate its constituents, components and intended uses), and providing a list of relevant product characteristics and other applicable properties.

When a product characteristic or other applicable property is specific to one of the Essential Requirements, it is dealt with in the appropriate place. If, however, the characteristic or property is relevant to more than one Essential Requirement, it is addressed under the most relevant one with cross reference to the other(s). This is especially important where a manufacturer claims “No performance determined” for a characteristic or property under one Essential Requirement and it is critical for the assessing and judging under another Essential Requirement. Similarly, characteristics or properties which have a bearing on durability assessments may be dealt with under ER 1 to ER 6, with reference under 4.7. Where there is a characteristic which only relates to durability, this is dealt with in 4.7.

This chapter also takes into account further requirements, if any (e.g. resulting from other EC Directives) and identifies aspects of serviceability including specifying characteristics needed to identify the products (re. ETA-format par. II.2.).

Each Essential Requirement is considered in turn.

The relevant Essential Requirements, the relevant paragraphs of the corresponding IDs and the related requirements to product performances are indicated in Table 1:

Table 1. Link between the mandate, the IDs and the related requirements to product performance

ER	Corresponding ID paragraph for works	Corresponding ID paragraph for product performance	Mandate product characteristic	ETAG paragraph on product performance
1	-	-	-	-
2	§ 4.2.4.2a Limitation of spread of fire to neighbouring construction works: roof coverings	§ 4.3.1.2.2 Roofs exposed to an external fire	External fire performance Reaction to fire of components	External fire performance Reaction to fire of relevant components
3	§ 3.3.1.2 Indoor environment: Dampness	§ 3.3.1.2.3.e.3 Dampness control: roofs, roofing materials	Watertightness Water vapour permeability Strength	Watertightness Water vapour permeability Strength
4	§ 3.3.1.2 Falling after slipping § 3.3.2.2 Impact of falling objects	§ 3.3.1.3 Falling after slipping § 3.3.2.3 Mechanical resistance and stability	Slipperiness Resistance to wind load	Slipperiness Resistance to wind load

5	-	-	-	-
6	§ 4.2 Energy consumption limitation	§ 4.3.2.2 Fabric components Table 4.2 Component characteristics	Thermal resistance	Thermal resistance
*)				Dimensional stability Resistance to deterioration caused by - physical agents - chemical agents

*) Aspects of durability, serviceability and identification

4.1 MECHANICAL RESISTANCE AND STABILITY:

Not relevant.

4.2 SAFETY IN CASE OF FIRE:

The Essential Requirement laid down in the COUNCIL DIRECTIVE 89/106/EEC is as follows:

The construction works shall be designed and built in such a way that in the event of an outbreak of fire:

- *the load bearing capacity of the construction can be assumed for a specific period of time.*
- *the generation and spread of fire and smoke within the works are limited.*
- *the spread of fire to neighbouring construction works is limited.*
- *occupants can leave the works or be rescued by other means.*
- *the safety of rescue teams is taken into consideration.*

The following aspects of performance are relevant to this Essential Requirement for Systems of mechanically fastened flexible roof waterproofing membranes:

External fire performance

The requirements for the external fire performance of the mechanically fastened flexible roof waterproofing kits shall be in accordance with laws, regulations and administrative provisions, applicable for the location where the product is incorporated in the works and will be classified via EN 13501-5.

Reaction to fire

Requirements for the reaction to fire of the components of the kits will be classified via EN 13501-1 and shall be in accordance with law, regulations and administrative provisions, applicable to the end use.

4.3 HYGIENE, HEALTH AND THE ENVIRONMENT

The Essential Requirement laid down in the COUNCIL DIRECTIVE 89/106/EEC is as follows:

The construction work shall be designed and built in such a way that it will not be a threat to the hygiene or health of the occupants or neighbours, in particular as a result of any of the following:

- *the giving-off of toxic gases*
- *the presence of dangerous particles or gases in the air*
- *the emission of dangerous radiation*
- *pollution or poisoning of the water or soil*
- *faulty elimination of waste water, smoke, solid or liquid wastes*
- *the presence of damp in parts of the works or on surfaces within the works.*

The following aspects of performance are relevant to this Essential Requirement for Systems of mechanically fastened flexible roof waterproofing membranes:

Indoor environment: Dampness

All materials and associated ancillary components of the roof covering shall be such that there will be no threat to the health of the occupants when the product is in service as a result of:

- vapour permeability
- water tightness

Systems of mechanically fastened flexible roof waterproofing membranes shall have sufficient strength so they will not be a threat to the hygiene or health of the occupants.

This means that they shall have sufficient strength to withstand accidentally large static and dynamic loads from the action of persons or objects and to withstand the static or dynamic loads from the fastening system without rupture of the membrane causing damp to penetrate the structure.

The loads may be in the form of:

- wind loads, snow loads, traffic loads etc.
- persons stepping directly on or beside one or more fasteners
- loads on joints and fasteners from snow, traffic, standing water etc.

Outdoor environment: Content and/or release of dangerous substances

Systems of mechanically fastened flexible roof waterproofing membranes shall be such that, when installed according to the appropriate provisions of the Member States, it allows for the satisfaction of the Essential Requirement 3 of the CPD as expressed by the national provisions of the Member States. Where applicable, the product shall also satisfy ER 3 in respect of the product being allowed to be placed on the market (for example meeting content restrictions).

4.4 SAFETY IN USE:

The Essential Requirement laid down in the COUNCIL DIRECTIVE 89/106/EEC is as follows:

The construction works shall be designed and built in such a way that it does not present unacceptable risks of accidents in service or in operation such as slipping, falling, collision, burns, electrocution, injury from explosion.

The following aspects of performance are relevant to this Essential Requirement for Systems of mechanically fastened flexible roof waterproofing membranes:

Slipperiness

The surface of the mechanically fastened flexible roof waterproofing membrane shall not be slippery due to either the inherent surface conditions or the presence of water or grease on the surface so that it will influence the probability of falling after slipping and thereby causing a risk for the occupants.

Mechanical resistance and stability

The systems of mechanically fastened flexible roof waterproofing membranes shall have sufficient strength to withstand the dynamic loads caused by wind loads without failure of the system in the form of:

a) Point or linear fasteners:

- failure of the fastener
 - in tension
 - in shear
 - in bending
 - in compression
- detachment of washer from fastener shaft
- failure of fastener sleeve or shank

b) Junction between point or linear fastener and load-bearing structure

- pull-out of fastener shaft
- loosening of junction between fastener shaft and load-bearing structure (lifting movement)
- unwinding of the fastener (pulsating movement)

c) Joints

- opening of the joint

d) Membrane

- mechanical failure of the membrane around the washer

4.5 PROTECTION AGAINST NOISE:

Not relevant.

4.6 ENERGY ECONOMY AND HEAT RETENTION

The Essential Requirement laid down in the COUNCIL DIRECTIVE 89/106/EEC is as follows:

The construction works and its heating and ventilation installations shall be designed and built in such a way that the amount of energy required in use shall be low, having regard to the climatic conditions of the location and the occupants.

The following aspects of performance are relevant to this Essential Requirement for systems of mechanically fastened flexible roof waterproofing membranes:

The entire roof shall be built with adequate properties in order to

- control energy consumption
- control water vapour condensing within the roof as a result of cold bridges from the metallic fasteners

Water vapour permeability is also related to ID3 and has therefore already been dealt with.

4.7 ASPECTS OF DURABILITY, SERVICEABILITY AND IDENTIFICATION

The requirements considered in the following are those which are related to the Essential Requirements, but not to any one in particular. As a consequence, failure to meet these requirements means that one or more of the Essential Requirements can no longer be met.

Dimensional stability

The mechanically fastened flexible roof waterproofing membrane including the system of fastening shall have sufficient dimensional stability in order to prevent reduction of mechanical or other properties.

Resistance to deterioration

Roof coverings shall have an adequate resistance to deterioration caused by physical or chemical agents in order to prevent reduction of mechanical or other properties. The agents include:

Physical agents

The loads may be in the form of:

- cyclic movement
- effect of high/low temperature
- effect of UV radiation
- ageing

Chemical agents

Water, carbon dioxide, oxygen (possible corrosion), sodium chloride solution (NaCl), saturated limewater ($\text{Ca}(\text{OH})_2$), sulphuric acid solution (H_2SO_4) and other normal chemical hazards, e.g. as mentioned for bituminous membranes in EN 13707, Annex C and for polymeric membranes in EN 13956, Annex C, likely to come into contact.

5. METHODS OF VERIFICATION

5.0 General

Chapter 5 refers to the verification methods used to determine the various aspects of performance of the products in relation to the requirements for the works (calculations, tests, engineering knowledge, site experience, etc.).

The relevant Essential Requirements, the related requirements for product performance (as given in chapter 4), the corresponding product characteristics to be assessed and the corresponding verification methods are indicated in the Table 2.

The possibility exists to use existing data in accordance with the EOTA Guidance Document on The Provision of Data for Assessments Leading to ETA.

The parts of Table 2 which are accentuated by “bold” framing indicate the minimum testing necessary to obtain an ETA for a kit (or the fastener), provided the characteristics of the membrane and insulation are given by CE marking based on other European technical specifications (see art 5.2).

Table 2. Product characteristics and corresponding verification methods

ER	ETAG paragraph on product performance	ETAG paragraph on verification method of product characteristic	
		SYSTEM	COMPONENT
2	§ 4.2 External fire performance Reaction to fire	§ 5.1.2 SYSTEM § 5.1.2.1 Testing of external fire performance	§ 5.2.2 MEMBRANE § 5.2.2.1 Testing of the reaction to fire § 5.4.2 INSULATION § 5.4.2.1 Testing of the reaction to fire
3	§ 4.3 Water tightness Water vapour permeability Strength Content and/or release of dangerous substances	§ 5.1.3 SYSTEM § 5.1.3.1 Content and/or release of dangerous substances	§ 5.2.3 MEMBRANE § 5.2.3.1 Testing of peel resistance (joint) § 5.2.3.2 Testing of shear resistance (joint) § 5.2.3.3 Testing of resistance to tear § 5.2.3.4 Testing of resistance to cold bending/folding § 5.2.3.5 Testing of resistance to water pressure § 5.2.3.6 Determination of water vapour permeability § 5.2.3.7 Determination of tensile properties § 5.2.3.8 Testing of resistance to static loading and impact loading § 5.2.3.9 Determination of dimensional stability § 5.2.3.10 Determination of thickness § 5.2.3.11 Determination of flow resistance § 5.4.3 INSULATION § 5.4.3.1 Compressibility test
4	§ 4.4 Slipperiness Resistance to wind load	§ 5.1.4 SYSTEM § 5.1.4.1 Wind uplift test	§ 5.2.4 MEMBRANE § 5.2.4.1 Slipperiness § 5.3.4 MECHANICAL FASTENERS See annex D

6	§ 4.6 Thermal resistance		§ 5.4.6 INSULATION § 5.4.6.1 Calculation or testing of thermal transmission
)	§ 4.7 Dimensional stability Resistance to deterioration caused by - physical agents - chemical agents		§ 5.2.7 MEMBRANE § 5.2.7.1 Testing of peel resistance after long term exposure to heat and water) § 5.2.7.2 Testing of shear resistance after long term exposure to heat and water*) § 5.2.7.3 Resistance to cold bending/folding after long term exposure to heat, UV, water and ozone § 5.3.7 MECHANICAL FASTENERS See annex D

*)Aspects of durability, serviceability and identification

5.1 SYSTEM

5.1.1 MECHANICAL RESISTANCE AND STABILITY (ER1)

Not relevant

5.1.2 SAFETY IN CASE OF FIRE (ER2)

5.1.2.1 External fire performance

The roof (including the complete roof covering) in which the kit is intended to be incorporated, installed or applied shall be tested using the test method relevant for the corresponding external fire performance roof class, in order to be classified according to EN 13501-5.

Or

The roof (including the complete roof covering) in which the kit is intended to be incorporated, installed or applied is considered "deemed to satisfy" all the provisions for external fire performance of all national regulations of the Member States without the need for testing on the basis that it is included within the definitions given in EC decision 2000/553/EC and provided that any national provisions on the design and execution of works are fulfilled.

Or

The roof (including the complete roof covering) in which the kit is intended to be incorporated, installed or applied is considered to satisfy the requirements for the relevant performance class of the characteristic external fire performance in accordance with the EC decision ...*(add reference)* without the need for further testing on the basis of its conformity with the specification of the product detailed in that decision and its intended end use application being covered by that decision..

5.1.3 HYGIENE, HEALTH AND THE ENVIRONMENT (ER3)

5.1.3.1 Content and/or release of dangerous substances

The applicant shall either

- submit the chemical constitution and composition of the materials and components of the systems of mechanically fastened flexible roof waterproofing membranes to the Approval Body which will observe strict rules of confidentiality

or

- submit a written declaration to the Approval Body stating whether or not and in which concentration the materials and components of the systems of mechanically fastened flexible roof waterproofing membranes contain substances which have to be classified as dangerous according to Directive 67/548/EEC and Regulation (EC) No 1272/2008 and listed in the "Indicative list on dangerous substances" of the EGDS - taking into account the installation conditions of the construction product and the release scenarios resulting from there.

Biocides in general and chemicals used to protect the membrane from root penetration shall be indicated with product name and content.

The use of recycled materials shall always be indicated, because this could lead to the implementation of further assessment and verification methods.

The information concerning the presence of dangerous substances listed in Council Directive 67/548/EEC and Regulation (EC) No 1272/2008 regulated at European level and listed in the "Indicative list on dangerous substances" of the EGDS and/or of other dangerous substances, shall be circulated as part of the evaluation report by the issuing Approval Body to the other Approval Bodies, under strict conditions of confidentiality.

5.1.3.1.1 Method of verification

Materials and components of the systems of mechanically fastened flexible roof waterproofing membranes listed in the EOTA TR 034 "General Checklist for ETAGs/CUAPs/ETAs - Content and/or release of dangerous substances in products/kits ", which have to be considered will be verified by the given methods, taking into account the installation conditions of the assembled system/component of the assembled system and the release scenarios resulting from there. Regulations related to placing the product on the market may also need to be taken into account.

Regarding the release scenarios referred to in the EOTA TR 034, the following use categories have to be considered:

- | | |
|----------------|---|
| Category S/W1: | Product with direct contact to soil-, ground- and surface water |
| Category S/W2: | Product with no direct contact to but possible impact on soil-, ground- and surface water |
| Category S/W3: | Product with no contact to and no impact on soil-, ground- and surface water |

Category S/W1 is applicable for products which are in contact with soil or water in a way that dangerous substances could be released directly out of the product.

Category S/W2 is applicable for products which can be leached by rain and could release dangerous substances which can have impact on soil and water.

Category S/W3 is applicable for products which are completely covered with tight products capable of avoiding any kind of migration of dangerous substances to soil or water.

Note: Content restrictions have to be considered in all cases.

5.1.4 SAFETY IN USE (ER4)

5.1.4.1 Wind uplift test

Concept of full scale and small scale testing:

Full scale testing

At least one combination of components is tested in the full scale wind uplift test. Determination of a representative combination to be tested is done in co-operation with the applicant. The combination that is tested will have the highest characteristic resistance of the combinations mentioned in the approval. The characteristic resistances of other combinations are found by interpolation based on either calculation, if possible, or on small scale testing. Extrapolation to a higher value from the full scale test results is **not** an option because of the uncertainty of the failure mode. Depending on the

experience of the approval body and test laboratory a full scale wind uplift test can be performed on the weakest assembled system as well, to determine the lower boundary of the interpolation.

Whilst there will always be at least **one** full scale wind uplift test, the applicant can always request additional full scale wind uplift tests on other combinations.

Small scale testing

Purpose of small scale testing:

- to form the basis for interpolation
- to reduce the amount of full scale testing

Principles/limitations on the use of small scale testing:

The test results are used to calculate a k-value smaller than 1.

Each change of component will lead to a k-value. Additional changes will lead to additional application of the k-value

Additional limitations on the use of the small scale test concept shall be determined by the test laboratory and the approval body in co-operation, based on their experience.

Procedure for the use of small scale testing:

Based on the characteristic resistance of the kit determined in the full scale wind uplift test, the characteristic resistance of other combinations can be calculated using the following formula:

$$W_{adm,nc} = k \times W_{adm,oc}$$

where

$W_{adm,nc}$ is the admissible (design) load per fastener of the new combination

$W_{adm,oc}$ is the admissible (design) load per fastener of the original combination (as determined in the full scale wind uplift test)

k is a correlation factor between the strength of the new combination and the original combination, both determined by small scale testing.

The factor k can never be smaller than 0,5 or larger than 1,0. If the k-value is smaller than 0,5, the small scale concept can not be used and a new full scale test is necessary

Determination of k value:

The determination method is based on the characteristics of each **component** either derived by small scale testing or obtained from the documents accompanying a CE-marked product. In case of testing, the tests are performed on new materials.

There are four possibilities for changes which can be covered by small scale testing: Variations to the fastener, variations to the membrane, variations to the jointing technique and variations in the substrate. Variations to the fastener are covered by the annex D concerning the issue of ETA's for fasteners and table D.1 describes the conditions for the assessment. The following clauses give an overview of possible changes and where the small scale tests can be used and which tests should be performed.

Changing of the membrane

Table 3a. Overview of small scale testing for changing the membrane

Change of the membrane element	Test concept applicable		
	Tensile test, T	Tear test, Te	Peel test, P
• Material group (within family)*)	X	X	-
• Reinforcement (within family)	X	X	X
• Thickness	X	X	-

*) Distinction is made between material families; bitumen reinforced sheets according EN 13707 and plastic and rubber sheets according EN 13956.

Within EN 13707 distinctions are made between material groups: oxidized bitumen, elastomeric bitumen and plastomeric bitumen. This grouping shall be taken into account

Example of material type: SBS, APP

Within EN 13956 distinctions are made between material groups: plastics, rubbers and thermoplastic rubbers. This grouping shall be taken into account Example of material groups: EVAC, FPP, PIB, PVC, EPDM, TPE, FPO, ECB

The small scale concept is only possible between products from the same material group.

The above concept is valid only if the following conditions are fulfilled:

$$0,7 < T_{nc} / T_{oc} \text{ (if } T_{nc} / T_{oc} > 1 \text{ then maximum calculation value} = 1)$$

$$0,7 < Te_{nc} / Te_{oc} \text{ (if } Te_{nc} / Te_{oc} > 1 \text{ then maximum calculation value} = 1)$$

$$k = (T_{nc} / T_{oc}) * (Te_{nc} / Te_{oc})$$

$$0,7 < P_{nc} / P_{oc} \text{ (if } P_{nc} / P_{oc} > 1 \text{ then maximum calculation value} = 1)$$

$$k = (T_{nc} / T_{oc}) * (Te_{nc} / Te_{oc}) * (P_{nc} / P_{oc})$$

For changes only affecting the peel resistance, the following reduction factor shall be taken into account.

$$k = P_{nc} / P_{oc}$$

P_{nc}: peel resistance of new element

P_{oc}: peel resistance of old element

Changing of the jointing technique

Table 3b. Overview of small scale testing for changing the jointing technique

Changes to jointing technique	
	Peeling test
▪ New jointing technique (see 3.2.7)	X

$$k = P_{nc} / P_{oc}$$

P_{nc}: peel resistance of new element

P_{oc}: peel resistance of old element

Description of the small scale tests

Peel resistance: According to § 5.2.3.1 of this Guideline

Tear resistance: According to § 5.2.3.3 of this Guideline

Tensile properties: According to § 5.2.3.7 of this Guideline

Changing of the substrate

The following principles apply when changing the substrate within the same family.

If a new timber or steel substrate is thicker and/or stronger or if a new concrete substrate has a higher compressive strength and density than the one used in the full scale test, a new test is not necessary. The value determined in the full scale test will be valid for the new substrates. The factor k is in this case k=1.

In addition, the value determined in the full scale test on a steel substrate can be valid for other substrates (concrete, aerated concrete, wood and wood based panels), provided that the characteristic axial loading resistance of the fastener in the other substrate is greater than or equal to the characteristic axial loading resistance of the fastener in the steel substrate (as applied in the full scale test). The factor k is in this case 1.

Changing of the fastener

The overview of small scale testing for variations in the fasteners is given in annex D. The following reduction factor(s) shall be taken into account:

$$k = R_{nc}/R_{oc}$$

R_{nc}: Resistance of new element

R_{oc}: Resistance of old element

Full scale wind uplift test

The test can be carried out in accordance with EN 16002 or as described below. The test results are considered to be equivalent.

General

The test is performed on the whole assembled system, i.e. the load-bearing structure, the insulation (if part of the system) and the mechanically fastened membrane. Even if a vapour control layer is a part of the system the test is carried out without the vapour control layer, since this may influence the failure loads in a positive way and the test shall be carried out in a worst case scenario. The test results will also then be applicable when the vapour control layer is included in the assembled system.

For systems with a mineral wool insulation thickness of $0 \text{ mm} < t \leq 350 \text{ mm}$, the thickness of the insulation material used in the test shall be 100 mm. The insulation material used in the test shall be specified by the applicant and stated in the ETA. The compressibility (10 %) according to EN 826 and the point load behaviour according to EN 12430 shall be specified and the results are valid for insulation materials with a compressibility higher than or equal to the one used in the test.

Apparatus

Pressure chamber of sufficient length and width to accommodate the dimensions of the test specimen and with such height, that the applied pressure is equally distributed and not affected by deformations, if any, of the test specimen.

Tests may be performed on systems of different dimensions, however the minimum effective dimension of the test rig for the full scale wind uplift test shall be 2 m × 2 m:

A test system of standard dimensions is preferred:

$$(\alpha \times a + 200 \text{ mm}) \times (\beta \times b + 200 \text{ mm})$$

consisting of $(\alpha + 1)$ rows and $(\beta + 1)$ fasteners

where α = number of spaces between rows of fasteners
 β = number of spaces between fasteners
 a = maximum spacing between rows of fasteners
 b = spacing between individual fasteners in a row

and consisting of at least 3 rows of 5 fasteners

$$(2 \times a + 200 \text{ mm}) \times (4 \times b + 200 \text{ mm})$$

or consisting of at least 4 rows of 4 fasteners

$$(3 \times a + 200 \text{ mm}) \times (3 \times b + 200 \text{ mm})$$

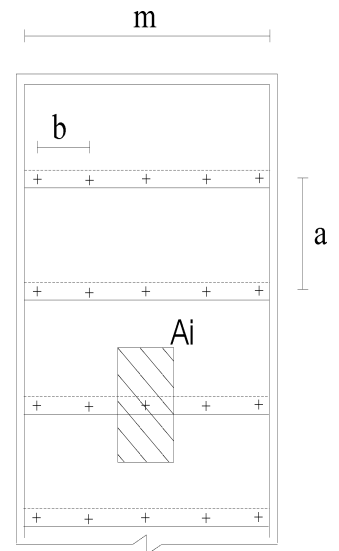

Figure 2: Definition of dimensions

The pressure chamber is provided with one or more windows, in such a way, that the test specimen can be observed during the testing.

The pressure chamber shall be capable of resisting a suction of 10 kPa. It shall be possible to create an airtight seal between the test specimen and the pressure chamber.

Fan, controlling equipment and recording equipment is connected to the pressure chamber, to achieve dynamic pressure cycles, each with a proportional sequence of loads according to figure 3 and a load accuracy of $\pm 10\%$ for loads above 2000 Pa.

The substrate of the test rig will depend on the type of fastener and the wishes of the applicant. If the applicant does not specify a particular substrate the following shall be used depending on whether the fastener is for concrete, timber or steel:

- Concrete shall generally be normal weight concrete strength class C25 according to EN 206 with a thickness of at least 100 mm. If there is a range of concrete strengths, the most critical shall be tested and the value found shall be used for other types of concrete.
- Plywood shall be grade 2 or 3 according to EN 636 with a nominal thickness of 19 mm, unless otherwise required by the applicant.
- Steel decks shall be galvanised, min. 0,70 mm, specifications min. S280 according to EN 10346 and the value found may be valid for all thicker and/or stronger steel decks.

If the applicant wishes the test to be performed on another specific substrate (for example oriented strand board (OSB) or aerated or lightweight concrete or profiles steel sheets with a thickness lower than 0,7 mm, i.e. 0,65 mm S320 GD+Z or S320 GD+Z) this shall be used in the test and the value found can be valid for other stronger substrates of the same type.

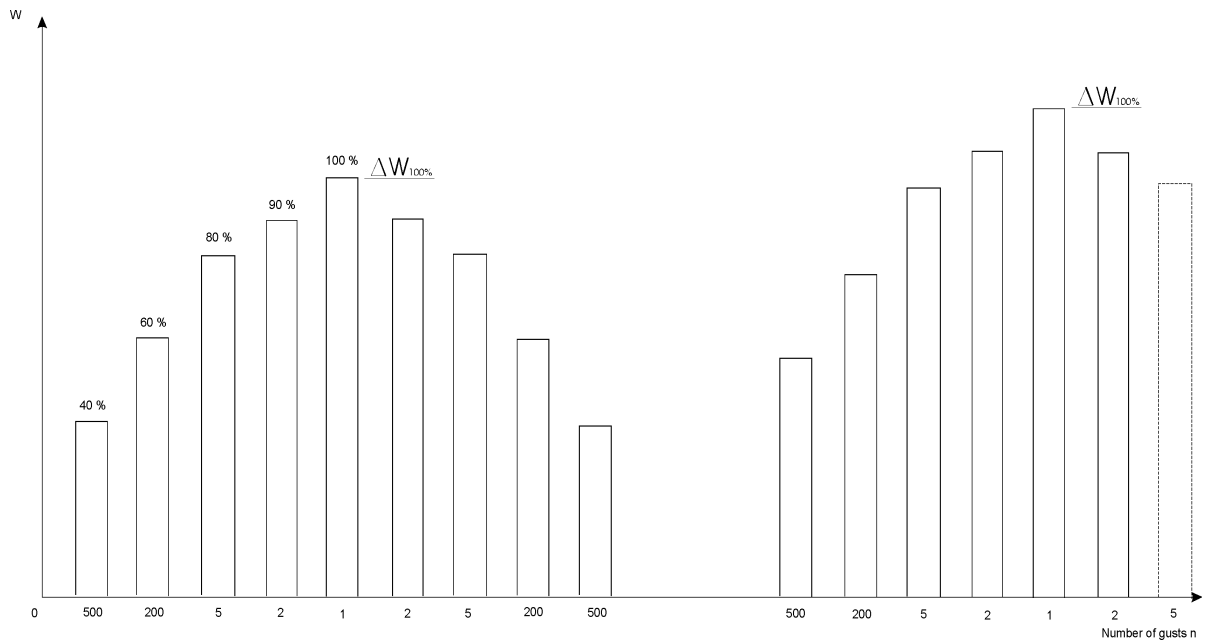

Figure 3: Proportional sequence of suction loads.

Test specimen

The test specimen is a model of a roof construction, incorporating a mechanically fastened flexible roof waterproofing membrane kit. If the insulation material is an integral part of the system the kit it shall be described in as much detail as possible by giving information on the compressive strength, density and other characteristics.

The sheets shall be symmetrically positioned and, independently of the width of the sheets, there shall be three rows of fasteners and the middle row shall run through the centre of the box. The kit shall be installed according to the manufacturers installation guide.

The number of test specimens is one.

The test specimen shall be conditioned at $23^{\circ}\text{C} \pm 5^{\circ}\text{C}$ for at least 16 h.

Test procedure

The test shall be carried out at $23^{\circ}\text{C} \pm 5^{\circ}\text{C}$

The test specimen shall be fixed symmetrically in the pressure chamber. The membrane shall be clamped airtight between the edges of the pressure chamber and the support structure to assure an airtight seal over the complete length of the edges. For kits with linear fasteners the edge can be made with an expansion loop on the membrane.

The fan, the controlling and recording equipment shall be used to apply and control the proportional load pattern and number of gusts (cycles) (figure 3) as dynamic pressure cycles on the test specimen.

The peak loads of each cycle in figure 3 are listed in Table 4:

Table 4. Peak loads of each cycle ($\Delta W_{100\%}$)

Number of cycles	Load per fastener in N ($\Delta W_{100\%}$)
1	300
1	300
1	300
1	300
1	400
1	500
1	600
1	700
.	.
.	.
.	.
1	2000
1	2100

The applied load shall correspond with the time/pressure diagram shown in figure 4. The tolerance on the time is $\pm 0,1$ sec and 90 % of the peak load shall be reached in between 0,7 - 1,0 sec. after the loading has started.

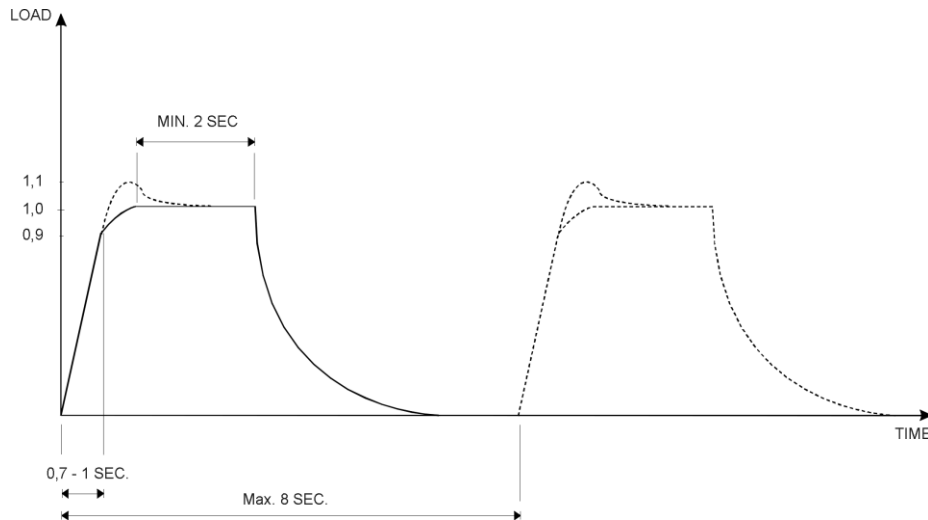

Figure 4: Time/pressure diagram

The behaviour of the test specimen shall be observed during each cycle; the stage, the number of cycles and the mode of failure, at which the system fails, shall be recorded.

The test is carried out with increasing loads (in steps of 100 N as indicated in Table 4) until failure of the system or to the limit of the test equipment. The loads quoted per fastener are calculated loads derived

by multiplication of the area of influence A_i (see Figure 2) by the difference between the laboratory pressure P_{lab} and the reduced pressure in the pressure chamber $P_{chamb.}$:

$$W_{test} = P_w \times A_i = (P_{lab} - P_{chamb.}) \times A_i$$

It shall be ensured that, for each application, the pressure effectively stresses the membrane. The pressure under the membrane and the pressure in the laboratory are monitored and if the deviation is more than 10% the substrate shall be perforated additionally to fully stress the membrane.

The test load W_{test} in N is converted in kPa according to the following formula:

$$(\text{Load in N/1000}) \times \text{amount of fasteners pr. m}^2$$

To obtain the corrected load $W_{corr.}$ of a fastener the test load W_{test} is reduced by the factors C_a and C_d as indicated below. The values of C_a and C_d are selected as a function of the chosen test system.

$$W_{corr.} = W_{test} \times C_a \times C_d$$

where W_{test} = maximum load in the cycle preceding the failure cycle

$W_{corr.}$ = corrected load taking into account the correction factors C_a and C_d

C_a = a geometric factor allowing for the difference between the deformation of the waterproof covering in the test and the real deformation for the membrane on a complete roof. The factor C_a depends on the parameters a/b and m/b , where m is the length of the shorter side of the test system. The factor C_a can be determined from figure 5 and for the three test systems given below, is ≤ 1

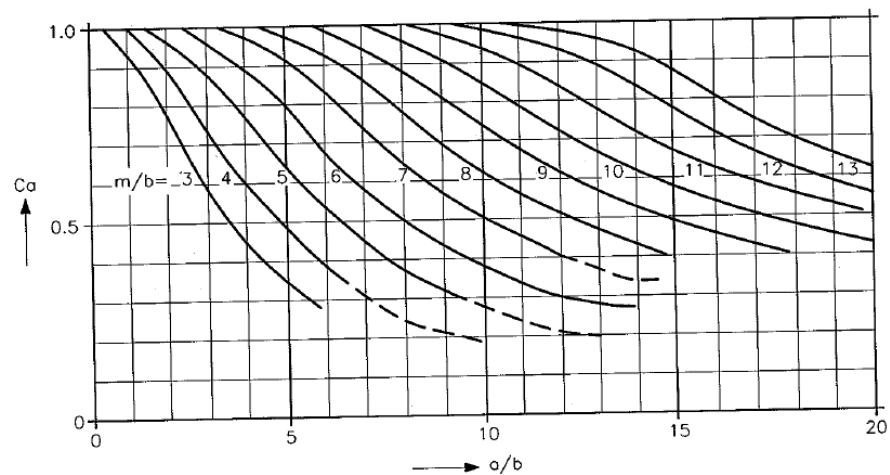

Figure 5: Determination of the factor C_a

On substrates where the fasteners are fixed through the substrate, the correction factor C_a can also be obtained by using a load-cell during the test. In order to perform a representative test it is important that the fixing pattern is regular. The washer and the upper part of the fastener shall be representative of the fastening system being evaluated. The lower part of the fastener is connected to the load-cell through a hole in the substrate. At installation of the model the washer shall be pressed on to the system with a force of $220 \text{ N} \pm 10 \%$.

At the maximum pressure just before the sample collapses the actual force is registered. As soon as the initial force of 220 N has dropped to 20 N the system is also deemed to have collapsed.

The correction factor is specified as:

$$C_a = \text{measured force/theoretical force at the same point}$$

C_d = a statistical factor allowing for the reduction in the probability of failure of one fastener, due to the reduced number of fasteners in the test system. The values of C_d as a function of the dimension of the chosen test system are given below

for	$(2 \times a + 200 \text{ mm}) \times (4 \times b + 200 \text{ mm})$	$C_d = 0,85$
for	$(3 \times a + 200 \text{ mm}) \times (3 \times b + 200 \text{ mm})$ and $(2 \times a + 200 \text{ mm}) \times (5 \times b + 200 \text{ mm})$ and $(2 \times a + 200 \text{ mm}) \times (6 \times b + 200 \text{ mm})$ etc.	$C_d = 0,90$
for	$(3 \times a + 200 \text{ mm}) \times (4 \times b + 200 \text{ mm})$	
	for larger dimensions	$C_d = 1,0$

The dimensions $(2 \times a + 200 \text{ mm}) \times (3 \times b + 200 \text{ mm})$ are not allowed.

The admissible (design) load per fastener, W_{adm} is calculated according to the following formula:

$$W_{adm} = W_{corr}/1,5$$

Where 1,5 is relating to the effects of materials, quality of installation and the fact that only one test is performed.

5.1.5 PROTECTION AGAINST NOISE (ER5)

Not relevant

5.1.6 ENERGY ECONOMY AND HEAT RETENTION (ER6)

Only considered in relation to kits with a thermal insulation product as a component, see 5.4.6.1.

5.1.7 ASPECTS OF DURABILITY, SERVICEABILITY AND IDENTIFICATION

Not relevant.

5.2 COMPONENT / MEMBRANE

Where the membrane is already CE marked according to EN 13707 or EN 13956 and tested in accordance with the test methods mentioned hereafter, it is not necessary to repeat the tests. However, assessment still has to be carried out according to chapter 6 of this Guideline to ensure that the membrane is fit for the intended use. Where the membrane is not CE-marked the tests in this chapter shall be performed and an assessment according to the provisions in chapter 6 shall be carried out.

The test methods marked with *) in the following are repeated for durability purposes after appropriate ageing as described in art. 5.2.7.

5.2.1 MECHANICAL RESISTANCE AND STABILITY (ER1)

Not relevant

5.2.2 SAFETY IN CASE OF FIRE (ER2)

5.2.2.1 Testing of reaction to fire

The membrane shall be tested, using the test method(s) relevant for the corresponding reaction to fire class, in order to be classified according to EN 13501-1

Or

The membrane is considered to satisfy the requirements for performance class A1 of the characteristic reaction to fire, in accordance with the provisions of EC decision 96/603/EC (as amended) without the need for testing on the basis of its listing in that decision.

Or

The membrane is considered to satisfy the requirements for performance class ... (*indicate class*) of the characteristic reaction to fire in accordance with the EC decision (*add reference*) without the need for further testing on the basis of its conformity with the specification of the product detailed in that decision and its intended end use application being covered by that decision.

5.2.3 HYGIENE, HEALTH AND THE ENVIRONMENT (ER3)

The following table gives an overview of the required tests for different membrane types

Table 5. required tests for different membrane types

Characteristics	What to test for each material group			Remarks
	Plastic	Rubber	Bituminous (SBS; APP, OX)	
5.2.3.1 Peel resistance of joints	only perpendicular to the length of the seam minimum thickness each welding method homogenous and reinforced	only perpendicular to the length of the seam minimum thickness each assembly system homogenous and reinforced	only one direction (width) minimum thickness each welding method	
5.2.3.2 Shear resistance of joints	only perpendicular to the length of the seam minimum thickness each welding method homogenous and reinforced	only perpendicular to the length of the seam minimum thickness each assembly system homogenous and reinforced	only one direction (width) minimum thickness each welding method	
5.2.3.3 Tear resistance	minimum thickness direction of lowest tensile strength homogenous and reinforced	minimum thickness both directions homogenous and reinforced	minimum thickness only one direction (width) direction of lowest tensile strength each reinforcement	
5.2.3.4 Cold bending	maximum thickness* homogenous and reinforced	maximum thickness* homogenous and reinforced	maximum thickness	*only on the upper side of the membrane
5.2.3.5 Water pressure	minimum thickness homogenous and reinforced	minimum thickness homogenous and reinforced	minimum thickness	
5.2.3.6	one thickness	one thickness	one thickness	Other thicknesses can

Vapour permeability				be calculated
5.2.3.7 Tensile properties	minimum thickness homogenous and reinforced	minimum thickness homogenous and reinforced	minimum thickness each reinforcement	
5.2.3.8 Static loading	minimum thickness homogenous and reinforced	minimum thickness homogenous and reinforced	minimum thickness	
5.2.3.8 Impact loading	minimum thickness homogenous and reinforced	minimum thickness homogenous and reinforced	minimum thickness	
5.2.3.9 Dimensional stability	minimum thickness Direction length	minimum thickness Direction length	minimum thickness Direction length	
5.2.3.10 Thickness	All thicknesses	All thicknesses	All thicknesses	
5.2.3.11 Determination of the flow resistance at elevated temperatures	Not relevant	Not relevant	Minimum thickness	
5.2.4.1 Slipperiness	one test per polymer base and per profile type	one test per polymer base	not relevant	
Ageing tests				
5.2.7.1 Peel resistance of joints after water/heat exposure	only perpendicular to the length of the seam minimum thickness each welding method homogenous and reinforced	only perpendicular to the length of the seam minimum thickness each jointing technique homogenous and reinforced	only one direction minimum thickness each welding method	
5.2.7.2 Shear resistance of joints after heat exposure	only perpendicular to the length of the seam minimum thickness each welding method homogenous and reinforced	only perpendicular to the length of the seam minimum thickness each jointing technique homogenous and reinforced	only one direction minimum thickness each welding method	-
5.2.7.3 Cold bending after heat/UV exposure	maximum thickness homogenous and reinforced	maximum thickness homogenous and reinforced	thickest	EN 1297 can be used

5.2.3.1 Testing of peel resistance of joints (for single-layer waterproof coverings only)*

Testing of the membrane with respect to peel resistance is performed as described in:

EN 12316-1 for bitumen sheets and EN 12316-2 for plastic and rubber sheets

5.2.3.2 Testing of shear resistance of joints (for single-layer waterproof coverings only)*)

Testing the system with respect to joint strength is performed as described in
EN 12317-1 for bitumen sheets and EN 12317-2 for plastic and rubber sheets

5.2.3.3 Resistance to tear

Testing of the membrane with respect to tear resistance is performed as described in:
EN 12310-1 for bitumen sheets and EN 12310-2 for plastic and rubber sheets

5.2.3.4 Resistance to cold bending/folding *)

Testing of the membrane with respect to resistance to cold bending is performed as described in:
EN 1109 for bitumen sheets and EN 495-5 for plastic and rubber sheets

5.2.3.5 Testing of resistance to water pressure

Testing of the membrane with respect to resistance to water pressure is performed as described in:
EN 1928; test A or B at ≥ 10 kPa

5.2.3.6 Determination of water vapour permeability

Declaration of a generic value or testing of the membrane with respect to water vapour permeability is performed as described in:
EN 1931

5.2.3.7 Determination of tensile properties

Testing of the membrane with respect to tensile properties is performed as described in:
EN 12311-1 for bitumen sheets and EN 12311-2 for plastic and rubber sheets

5.2.3.8 Testing of resistance to static loading and impact loading

Testing of the kit with respect to resistance to static loading and impact loading is performed as described in:
EN 12730 for static loading and EN 12691 for impact resistance.

5.2.3.9 Determination of dimensional stability

Testing of the membrane with respect to dimensional stability is performed as described in:
EN 1107-1 for bitumen sheets and EN 1107-2 for plastic and rubber sheets

5.2.3.10 Determination of thickness

Testing of the membrane with respect to the thickness is performed as described in:
EN 1849-1 for bitumen sheets and EN 1849-2 for plastic and rubber sheets

5.2.3.11 Determination of the flow resistance at elevated temperature for bituminous sheets

Testing of the membrane with respect to the flow resistance at elevated temperature is performed as described in:

EN 1110 for bitumen sheets

5.2.4 SAFETY IN USE (ER4)

5.2.4.1 SLIPPERINESS

The coefficient of friction is determined in accordance with the Swedish standard

SS 92 35 15, (2) – Method for determination of the coefficients of friction of various materials with respect to slipping.

Roof surfaces of bituminous products are considered deemed to satisfy the requirements and the test is not performed on this material.

5.2.5 PROTECTION AGAINST NOISE (ER5)

Not relevant

5.2.6 ENERGY ECONOMY AND HEAT RETENTION (ER6)

Not relevant

5.2.7 ASPECTS OF DURABILITY, SERVICEABILITY AND IDENTIFICATION

5.2.7.0 General

Ageing tests specific for the membrane as component of a MEFAWAME kit.

The characteristics to be tested and assessed and the relevant ageing media are shown in Table 6.

Table 6. Characteristics to be tested and assessed and ageing media

(N/A means Not Applicable)

Ageing media	HEAT	UV	WATER	OZONE
Characteristics				
PEEL RESISTANCE	ETAG art. 5.2.7.1 ETAG art. 6.2.7.1	N/A N/A	ETAG art. 5.2.7.1 **) ETAG art. 6.2.7.1 **)	N/A N/A
SHEAR RESISTANCE	ETAG art. 5.2.7.2 ETAG art. 6.2.7.2	N/A N/A	N/A N/A	N/A N/A
RESISTANCE TO COLDBENDING/FOLDING	ETAG art. 5.2.7.3 ETAG art. 6.2.7.3	ETAG art. 5.2.7.3 ETAG art. 6.2.7.3	N/A N/A	ETAG art. 5.2.7.3 ETAG art. 6.2.7.3

**) for adhered joints only

5.2.7.1 Testing of peel resistance after long term exposure to heat and water

The membrane is conditioned as described in:

- for heat: EN 1296 (for bituminous and polymeric membranes) for 28 days at $70 \pm 2^\circ\text{C}$
- for water: EN 1847 for 28 days at $60 \pm 2^\circ\text{C}$ (for polymeric membranes)

After each conditioning the membrane is tested with respect to peel resistance after ageing and performed as described in 5.2.3.1 of this Guideline.

5.2.7.2 Testing of shear resistance after long term exposure to heat

The membrane is conditioned as described in:

- for heat: EN 1296 (for bituminous and polymeric membranes) for 28 days at $70 \pm 2^\circ\text{C}$

After each conditioning the membrane is tested with respect to shear resistance after ageing and performed as described in 5.2.3.2 of this Guideline.

5.2.7.3 Resistance to cold bending/folding after long term exposure to heat, UV and ozone

The membrane is conditioned as described in:

- for heat: EN 1296 (for bituminous membranes) for 84 days at $70 \pm 2^\circ\text{C}$
- for UV: according to EN 1297 during 1000 h according to the product standard or according to EOTA Technical Report no. 10 using Climate Class S and a radiant exposure equivalent to 2 years *)
- for ozone: according to EN 1844 for 168 hours at $40 \pm 2^\circ\text{C}$ and relative humidity $65 \pm 5\%$ **)

After each conditioning the membrane is tested with respect to resistance to cold bending/folding after ageing and performed as described in 5.2.3.4 of this Guideline.

*) The UV test is not performed on mineral finished materials with a good granule retention (according to EN 12039).

***) The ozone test only applies to elastomeric membranes.

5.3 COMPONENT / MECHANICAL FASTENINGS

See annex D

5.3.1 MECHANICAL RESISTANCE AND STABILITY (ER1)

Not relevant

5.3.2 SAFETY IN CASE OF FIRE (ER2)

The fastening shall be tested, using the test method(s) relevant for the corresponding reaction to fire class, in order to be classified according to EN 13501-1

Or

The fastening is considered to satisfy the requirements for performance class A1 of the characteristic reaction to fire, in accordance with the provisions of EC decision 96/603/EC (as amended) without the need for testing on the basis of its listing in that decision.

Or

The fastening is considered to satisfy the requirements for performance class ...(*indicate class*) of the characteristic reaction to fire in accordance with the EC decision (*add reference*) without the need for further testing on the basis of its conformity with the specification of the product detailed in that decision and its intended end use application being covered by that decision

5.3.3 HYGIENE, HEALTH AND THE ENVIRONMENT (ER3)

Not relevant

5.3.4 SAFETY IN USE (ER4)

See annex D

5.3.5 PROTECTION AGAINST NOISE (ER5)

Not relevant

5.3.6 ENERGY ECONOMY AND HEAT RETENTION (ER6)

Not relevant

5.3.7 ASPECTS OF DURABILITY, SERVICEABILITY AND IDENTIFICATION

See annex D

5.4 COMPONENT / INSULATION

Generally the insulation material shall be classified according to the relevant harmonised standards

Where the insulation material is already CE marked and tested in accordance with the test methods mentioned hereafter, it is not necessary to repeat the tests. However, assessment still has to be carried out according to chapter 6 of this Guideline to ensure that the insulation material is fit for the intended use. Where the insulation material is not CE-marked the tests in this chapter shall be performed and an assessment according to the provisions in chapter 6 shall be carried out.

5.4.1 MECHANICAL RESISTANCE AND STABILITY (ER1)

Not relevant

5.4.2 SAFETY IN CASE OF FIRE (ER2)

5.4.2.1 Testing of reaction to fire

The insulation material shall be tested, using the test method(s) relevant for the corresponding reaction to fire class, in order to be classified according to EN 13501-1

Or

The insulation material is considered to satisfy the requirements for performance class A1 of the characteristic reaction to fire, in accordance with the provisions of EC decision 96/603/EC (as amended) without the need for testing on the basis of its listing in that decision.

Or

The insulation material is considered to satisfy the requirements for performance class ... (*indicate class*) of the characteristic reaction to fire in accordance with the EC decision (*add reference*) without the need for further testing on the basis of its conformity with the specification of the product detailed in that decision and its intended end use application being covered by that decision.

5.4.3 HYGIENE, HEALTH AND THE ENVIRONMENT (ER3)

5.4.3.1 Compressibility test for insulating materials

Determination of the compression behaviour and point load behaviour of the insulating materials is performed as described in:

EN 826 for the compression behaviour and additionally for the relevant insulation materials (EPS and MW)
EN 12430 for the point load behaviour.

5.4.4 SAFETY IN USE (ER4)

Not relevant

5.4.5 PROTECTION AGAINST NOISE (ER5)

Not relevant

5.4.6 ENERGY ECONOMY AND HEAT RETENTION (ER6)

5.4.6.1 Calculation or testing of thermal transmission

Calculation of the thermal insulation characteristics is performed as described in:

EN/ISO 6946:, Building components and building elements – Thermal resistance and thermal transmittance – Calculation method.

Testing of thermal resistance is performed as described in:

EN/ISO 8990, Thermal insulation – Determination of steady-state thermal transmission properties – calibrated and guarded hot box

EN 12667, Building materials – Determination of thermal resistance by means of guarded hot plate and heat flow meter methods – Products of high and medium thermal resistance

EN 12939, Building materials – Determination of thermal resistance by means of guarded hot plate and heat flow meter methods – Thick products of high and medium thermal resistance

EN/ISO 10211-1, Thermal bridges in building – Heat flows and surface temperatures – General calculation methods.

5.4.7 ASPECTS OF DURABILITY, SERVICEABILITY AND IDENTIFICATION

5.4.7.1 Durability of insulating materials

The durability of the thermal resistance of the insulation material is tested as described in in the relevant harmonized technical specification:

The durability of the thickness of the insulation material is tested as described in

EN 1604 – Thermal insulating products for building applications – Determination of dimensional stability under specified temperature and humidity conditions

The combination of the tests on the durability of the thermal resistance and of the thickness will provide information on the durability of the λ -value.

6. ASSESSING AND JUDGING OF THE FITNESS FOR USE OF PRODUCTS FOR AN INTENDED USE

6.0 General

Chapter 6 details the performance requirements to be met by a System of mechanically fastened flexible roof waterproofing membranes (chapter 4) into precise and measurable (as far as possible and proportional to the importance of the risk) or qualitative terms, related to the products and their intended use, using the verification methods (chapter 5).

The possible ways of expressing the results of the assessment of the mandatory performance requirements are shown in Table 7.

Table 7. Product performance and assessment criteria

ER	ETAG paragraph on product characteristic to be assessed	Category/Class/ Numeric value
2	§ 6.1.2 SYSTEM	Classification
	§ 6.1.2.1 External fire performance	
	§ 6.2.2 COMPONENT/MEMBRANE	Classification
	§ 6.2.2.1 Reaction to fire	
§ 6.4.2 COMPONENT/INSULATION	§ 6.4.2.1 Reaction to fire	Classification
3	§ 6.1.3 SYSTEM	Declaration
	§ 6.1.3.1 Content and/or release of dangerous substances	
	§ 6.2.3 COMPONENTS/MEMBRANE	Declared value Declared value Declared value Declared value Declared value Declared values Declared values Declared value Declared value Declared value
	§ 6.2.3.1 Peel resistance (joint) *)	
	§ 6.2.3.2 Shear resistance (joint) *)	
	§ 6.2.3.3 Tear resistance	
	§ 6.2.3.4 Resistance to cold bending/folding	
	§ 6.2.3.5 Resistance to water pressure	
	§ 6.2.3.6 Water vapour permeability	
	§ 6.2.3.7 Tensile properties	
	§ 6.2.3.8 Resistance to static loading and impact loading	
	§ 6.2.3.9 Dimensional stability	
	§ 6.2.3.10 Thickness	
§ 6.2.3.11 Flow resistance		
§ 6.4.3 COMPONENTS/INSULATION	Category	
§ 6.4.3.1 Compressibility of insulation materials		
4	§ 6.1.4 SYSTEM	Admissible (design) load
	§ 6.1.4.1 Resistance to wind uplift	
	§ 6.2.4 COMPONENT / MEMBRANE	Declared value or no performance determined
	§ 6.2.4.1 Slipperiness	

	§ 6.3.4 COMPONENTS/MECHANICAL FASTENERS § 6.3.4.1 Axial loading of fastener § 6.3.4.2 Resistance to unwinding § 6.3.4.3 Mechanical resistance of sleeve	See annex D
6	§ 6.4.6 COMPONENTS/INSULATION § 6.4.6.1 Thermal resistance	Characteristic value or No performance determined
**)	§ 6.2.7 COMPONENTS/MEMBRANE § 6.2.7.1 Peel resistance after long term exposure to heat and water § 6.2.7.2 Shear resistance after long term exposure to heat and water § 6.2.7.3 Resistance to cold bending/folding after long term exposure to heat, UV and water	Declared value and conclusion Declared value and conclusion Declared value and conclusion
	§ 6.3.7 COMPONENTS/MECHANICAL FASTENERS § 6.3.7.1 Resistance to corrosion of metallic fasteners § 6.3.7.2 Mechanical resistance after heat ageing of plastic fasteners	See annex D

*) for single layer systems only

***) Aspects of durability, serviceability and identification

6.1 SYSTEM

6.1.1 MECHANICAL RESISTANCE AND STABILITY (ER1)

Not relevant

6.1.2 SAFETY IN CASE OF FIRE (ER2)

6.1.2.1 External fire performance

The roof (including the complete roof covering) in which the kit is intended to be incorporated, installed or applied shall be classified according to EN 13501-5.

6.1.3 HYGIENE, HEALTH AND THE ENVIRONMENT (ER3)

6.1.3.1 Outdoor environment

Content and/or release of dangerous substances:

Systems of mechanically fastened flexible roof waterproofing membranes and/or constituents of the kit listed in the EOTA TR 034: "General Checklist for ETAGs/CUAPs/ETAs Content and/or release of dangerous substances in products/kits" (or equivalent EOTA document), and the related dangerous substances which have to be considered, will be assessed by the given methods taking into account the installation conditions of the construction product and the release scenarios resulting from there.

6.1.4 SAFETY IN USE (ER4)

6.1.4.1 Resistance to wind uplift

Admissible (design) load determined as the result of the wind uplift test and the possible small scale tests.

6.1.5 PROTECTION AGAINST NOISE (ER5)

Not relevant

6.1.6 ENERGY CONSUMPTION AND HEAT RETENTION (ER6)

Only considered in relation to kits with a thermal insulation material as a component (see 6.4.6.1).

6.1.7 ASPECTS OF DURABILITY, SERVICEABILITY AND IDENTIFICATION

Not relevant.

6.2 COMPONENT / MEMBRANE

6.2.1 MECHANICAL RESISTANCE AND STABILITY (ER1)

Not relevant

6.2.2 SAFETY IN CASE OF FIRE (ER2)

6.2.2.1 Reaction to fire

The product shall be classified according to EN 13501-1

6.2.3 HYGIENE, HEALTH AND THE ENVIRONMENT (ER3)

Test results marked with *) are also for durability purposes as described in art. 6.2.7.

6.2.3.1 Peel resistance of joints*)

Declared value

6.2.3.2 Shear resistance of joints*)

Declared value

6.2.3.3 Tear resistance *)

Declared value

6.2.3.4 Resistance to cold bending/folding*)

Declared value

6.2.3.5 Resistance to water pressure

Declared value

6.2.3.6 Water vapour permeability

Declared value

6.2.3.7 Tensile properties

Declared value

6.2.3.8 Resistance to static loading and impact loading

Declared value

6.2.3.9 Dimensional stability

Declared value

6.2.3.10 Thickness

Declared value

6.2.3.11 Flow resistance

Declared value

6.2.4 SAFETY IN USE (ER4)

6.2.4.1 Slipperiness

Indication of characteristic value or no performance determined.

6.2.5 PROTECTION AGAINST NOISE (ER5)

Not relevant

6.2.6 ENERGY CONSUMPTION AND HEAT RETENTION (ER6)

Not relevant

6.2.7 ASPECTS OF DURABILITY, SERVICEABILITY AND IDENTIFICATION

6.2.7.1 Peel resistance after long term exposure to heat and water

If the decrease in the peel resistance is equal to or less than 20 % after ageing this may be considered to be applicable to an expected working life of at least 10 years since the overall quality of the kit is proven by the wind uplift test.

If the decrease in the peel resistance is more than 20 % after ageing further investigations (e.g. establishing further points on the degradation curve and/or level of declared value after ageing) shall be undertaken by the Approval Body. This assessment shall be carried out in accordance with the provisions in EOTA Guidance Document for the Assessment of Working Life of Products, EOTA GD003, paragraph 4.3.4 Accelerated ageing conditions.

6.2.7.2 Shear resistance after long term exposure to heat and water

If the decrease in the shear resistance is equal to or less than 20 % after ageing this may be considered to be applicable to an expected working life of at least 10 years since the overall quality of the kit is proven by the wind uplift test.

If the decrease in the shear resistance is more than 20 % after ageing further investigations (e.g. establishing further points on the degradation curve and/or level of declared value after ageing) shall be undertaken by the Approval Body. This assessment shall be carried out in accordance with the provisions in EOTA Guidance Document for the Assessment of Working Life of Products, EOTA GD003, paragraph 4.3.4 Accelerated ageing conditions.

6.2.7.3 Resistance to cold bending/folding after long term exposure to heat, UV, water and ozone (for elastomeric membranes)

If the decrease in the resistance to cold bending/folding is equal to or less than 15°C after ageing this may be considered to be applicable to an expected working life of at least 10 years since the overall quality of the kit is proven by the wind uplift test.

If the decrease in the resistance to cold bending/folding is more than 15°C after ageing further investigations (e.g. establishing further points on the degradation curve and/or level of declared value after ageing) shall be undertaken by the Approval Body. This assessment shall be carried out in accordance with the provisions in EOTA Guidance Document for the Assessment of Working Life of Products, EOTA GD003, paragraph 4.3.4 Accelerated ageing conditions.

6.3 COMPONENT / MECHANICAL FASTENERS

See annex D

6.3.1 MECHANICAL RESISTANCE AND STABILITY (ER1)

Not relevant

6.3.2 SAFETY IN CASE OF FIRE (ER2)

Not relevant

6.3.3 HYGIENE, HEALTH AND THE ENVIRONMENT

Not relevant

6.3.4 SAFETY IN USE (ER4)

See annex D

6.3.5 PROTECTION AGAINST NOISE (ER5)

Not relevant

6.3.6 ENERGY CONSUMPTION AND HEAT RETENTION (ER6)

Not relevant

6.3.7 ASPECTS OF DURABILITY, SERVICEABILITY AND IDENTIFICATION

See annex D

6.4 COMPONENT / INSULATION

6.4.1 MECHANICAL RESISTANCE AND STABILITY (ER1)

Not relevant

6.4.2 SAFETY IN CASE OF FIRE (ER2)

6.4.2.1 Reaction to fire

The product shall be classified according to EN 13501-1:2002

6.4.3 HYGIENE, HEALTH AND THE ENVIRONMENT (ER3)

6.4.3.1 Compressibility test for insulation materials

Indication of category in accordance with EN 826 and additionally for relevant insulation materials (EPS and MW) EN 12430.

Compressibility (10 %) according to EN 826 and for the relevant insulation materials the point load behaviour according to EN 12430 used in the test shall be declared in the ETA. The compressibility applies to homogenous materials and the top layer of multi-layer or composite products.

6.4.4 SAFETY IN USE (ER4)

Not relevant

6.4.5 PROTECTION AGAINST NOISE (ER5)

Not relevant

6.4.6 ENERGY ECONOMY AND HEAT RETENTION (ER6)

6.4.6.1 Thermal resistance

Where the insulation material does not form part of the kit an assessment is not carried out. Otherwise, the thermal resistance of the insulation material used in the kit is indicated according to the standards mentioned in 5.4.6.1.

6.4.7 ASPECTS OF DURABILITY, SERVICEABILITY AND IDENTIFICATION

6.4.7.1 Durability of the insulating materials

The durability is assessed in accordance with the relevant product standards

6.8 IDENTIFICATION OF THE PRODUCT

All components of the mechanically fastened flexible roof waterproofing membrane kit shall be clearly identified. Where possible, this shall preferably be done by reference to European Standards. If this is not possible the reference shall be made by trade name.

Where components are not covered by European Standards, they shall be precisely defined by reference to physical characteristics as indicated in this Guideline.

The determination of the product characteristics shall be based on testing in accordance with the appropriate CEN or EOTA test methods as far as they exist.

7. **ASSUMPTIONS AND RECOMMENDATIONS under which the fitness for use of the products is assessed**

7.0 **General**

Chapter 7 sets out the preconditions for design, execution, maintenance and repair which are a presumption for the assessment of the fitness for use according to the Guideline (only when necessary and in so far as they have a bearing on the assessment or on the products).

The issued European Technical Approvals shall state these conditions, where relevant.

7.1 **DESIGN AND EXECUTION OF SYSTEMS OF MECHANICALLY FASTENED FLEXIBLE ROOF WATERPROOFING MEMBRANES INTO THE WORKS**

The substrate is assumed to fulfil the following basic requirements:

Design

The design of the roof intended to be covered by the mechanically fastened roof waterproofing system shall take account of the following factors:

- Dead and imposed loads
- Design wind pressure
- Structural strength, stiffness and deflection limits
- Attachment of the roof deck to the structural framing
- The provision of insulation
- The assessment of condensation risk and the provision of vapour control layers
- Sound insulation
- Fire precautions
- Roof attachments, fixtures and penetrations
- Falls and drainage
- Means of access for inspection and maintenance

The desired properties of the roof shall be determined and specified accordingly.

Substrates

The substrate onto which the waterproofing kit is to be laid shall be sufficiently rigid, dense and dimensionally stable to support the system (membrane and insulation). Its nature will depend on the type of roof selected (warm deck, cold deck, or inverted) and in turn will have a direct influence on the method of attachment.

In order to support the loads imposed by traffic, insulation materials for use in warm decks shall be capable of resisting permanent deformation or damage when subjected to concentrated loads. They shall have a dust-free surface and sufficient laminar strength to resist with a margin of safety any stress imposed by wind uplift forces.

It is assumed that the insulation material used on site has at least the same characteristics as the insulation material used in the wind uplift test and as stated in the ETA.

When insulation materials with a compressibility of $<0,1\text{Nmm}^{-2}$ (at 10% compression) are used, the membrane may be vulnerable to puncture by the fastener penetrating through the underside. This may be prevented by using a fastener/washer, strip or lath with an "anti-pop-up" design. These designs are often marketed as "Treadfast" and may feature a mechanical interlock between the fastener and the washer strip or lath, which is engaged upon fastener installation. Examples of other

designs include a deep recess in the washer, strip or lath, or a plastic washer with integrated sleeve.

Roof materials

The following is a list of recommendations for roof deck materials to receive the mechanically fastened roof waterproofing system.

- *Reinforced concrete.* Where a roof slab of reinforced concrete is designed as the deck, which will directly support the waterproofing, it is preferable to lay the slab to provide adequate drainage falls and adequate provision shall be made for drying out the slab. A concrete surface, which is not adequately smooth, or does not provide even drainage falls, shall be screeded. The surface of the concrete shall be finished with a wood float to provide a reasonably smooth surface free from ridges and hollows.
- *Profiled metal decking.* Metal decking does not provide a continuous supporting surface for the application of the waterproofing membrane and therefore it shall always be used in conjunction with a continuous support, e.g. insulation material. The metal decking shall not be less than 0,70 mm.
- *Timber boarding, including OSB.* Roof decks of timber boarding shall be designed using naturally durable timber or pre-treated against infestation by wood boring insects and fungal decay. Any method of pre-treatment shall be compatible with the kit components. Boarding shall not be less than 19 mm nominal thickness, planed, closely clamped together with tongued and grooved joints or closely butted and secured by nailing with nail heads not protruding.
- *Plywood.* Roof decks of plywood shall be specified as “water boil proof” bonded veneer plywood and durable or treated with a compatible preservative and shall not be less than 19 mm nominal thickness. Plywood for roof decks may be square edged or tongued and grooved. Longitudinal joints shall occur on the centre of supporting joists. Cross joists shall be staggered and in the case of square edged boarding additional support is required, such as the use of noggins.

If there is doubt about the suitability of the substrate, e.g. on a construction site, a pullout test on site shall be performed to verify the performance of the kit (see Annex C). Furthermore, care shall be taken during design that bimetallic corrosion between metal parts, especially between the substrate and the screw, does not occur. Likewise, the use of insulation materials containing substances which can affect the performance of the fasteners shall be avoided.

It is assumed that further conditions for design and execution of the system into the works shall be taken from the manufacturer's installation guide. The quality and sufficiency of this installation guide shall be assessed, in particular concerning the aspects indicated in chapter 9.1 of this Guideline; Information on the design.

It is recommended that it is stated in the ETA that the installation guide forms part of the ETA. The ETA holder is responsible for delivering the installation guide to the roofing contractor. The ETA may take over the essential parts of the installation guide.

7.2 PACKAGING, TRANSPORT AND STORAGE

The components of the kit shall be handled and stored with care and be protected from accidental damage.

7.3 EXECUTION OF WORKS

The kit shall be installed in accordance with the ETA holder's installation instructions by competent roofing contractors. ETA holders may operate an approved contractors scheme.

Extra care shall be taken when handling and installing the insulation material.

7.4 MAINTENANCE AND REPAIR

The assessment of the fitness for use is based on the assumption that a normal maintenance of the system is performed.

This maintenance shall include:

- inspections of the roof at regular intervals, e.g. twice a year
- this inspection shall include:
 - cleaning of downpipes and leaf filters
 - removal of stones, branches and leaves etc.
 - inspection of flashings along the edge of the roof, chimneys, drains and roof lights
 - removal of organic growths such as vines
- Elastic joints around cover strips shall be inspected every year and replaced if necessary
- Flashings to caps, drains etc. shall be inspected every year and joint sealants shall be replaced if necessary
- Inspection, and if necessary, replacement of mineral finishes on bituminous membranes
- Abrasions and minor impact damage shall be repaired.

It is recommended that the ETA contains the following statement; "If replacement components are not approved by the manufacturer or covered by the ETA, there can be no guarantee that the kit will continue to perform in accordance with the manufacturer's declared performance. In addition, the manufacturer would no longer be responsible for the intended working life of the kit".

Section Three: ATTESTATION OF CONFORMITY (AC)

8. ATTESTATION AND EVALUATION OF CONFORMITY

8.1 EC DECISION

The system of attestation of conformity specified by the European Commission in mandate Construct 97/223 Annex 3 is system 2+ described in Council Directive (89/106/EEC) Annex III, 2(ii), First possibility and is detailed as follows:

(a) **Tasks of the manufacturer**

- initial type-testing of the product
- factory production control

(b) **Tasks of the approved body**

- initial inspection of factory and of factory production control
- continuous surveillance, assessment and approval of factory production control

8.2 RESPONSIBILITIES

8.2.1 Tasks of the manufacturer covering the factory production control

8.2.1.1 **Factory production control**

The manufacturer shall exercise permanent internal control of production. All the elements, requirements and provisions adopted by the manufacturer shall be documented in a systematic manner in the form of written policies and procedures. This production control system shall ensure that the product is in conformity with the European Technical Approval (ETA).

Manufacturers having an FPC system which complies with EN ISO 9001 **and** which addresses the requirements of an ETA are recognised as satisfying the FPC requirements of the Directive.

8.2.1.2 **Declaration of Conformity**

When all the criteria of the Conformity Attestation are satisfied the manufacturer shall make a Declaration of Conformity.

8.2.2 Tasks of the manufacturer covering the product

8.2.2.1 **Initial Type Testing**

Approval tests will have been conducted by the approval body or under its responsibility (which may include a proportion conducted by a laboratory or by the manufacturer, witnessed by the approval body) in accordance with section 5 of this ETAG. The approval body will have assessed the results of these tests in accordance with section 6 of this ETAG, as part of the ETA issuing procedure.

These tests shall be used for the purposes of Initial Type Testing².

This work shall be taken over by the manufacturer for Declaration of Conformity purposes.

8.2.3 **Tasks of the approved body**

8.2.3.1 **Assessment of the factory production control system - initial inspection and continuous surveillance**

²In this respect Approval Bodies shall be able to have open arrangements with relevant Approved Bodies to avoid duplication, respecting each others responsibilities.

Assessment of the factory production control system is the responsibility of the approved body.

An assessment shall be carried out of each production unit to demonstrate that the factory production control is in conformity with the ETA and any subsidiary information. This assessment shall be based on an initial inspection of the factory.

Subsequently continuous surveillance of factory production control is necessary to ensure continuing conformity with the ETA.

It is recommended that surveillance inspections be conducted at least twice per year. However, if the results of the first inspection are satisfactory, the inspection interval can be reduced to once per year.

8.2.3.2 ***Certification of Factory Production Control***

The approved body shall issue a Certificate of Factory Production Control.

8.3 DOCUMENTATION

In order to help the approved body make an evaluation of conformity the approval body issuing the ETA shall supply the information detailed below. This information together with the requirements given in EC Guidance Paper B will generally form the basis on which the factory production control (FPC) is assessed by the approved body.

This information shall initially be prepared or collected by the approval body and shall be agreed with the manufacturer. The following gives guidance on the type of information required:

(1) The ETA

See section 9 of this Guideline.

The nature of any additional (confidential) information shall be declared in the ETA.

(2) Basic manufacturing process

The basic manufacturing process shall be described in sufficient detail to support the proposed FPC methods.

The different components of MEFAWAME are generally manufactured using conventional techniques. Any critical process or treatment of the components which affects the performance shall be highlighted.

(3) Product and materials specifications

These may include:

detailed drawings (including manufacturing tolerances)
incoming (raw) materials specifications and declarations
references to European and/or international standards or appropriate specifications
manufacturers data sheets.

(4) FPC test plan

The manufacturer and the approval body issuing the ETA shall agree an FPC test plan.

An agreed FPC test plan is necessary as current standards relating to quality management systems (Guidance Paper B, etc), do not ensure that the product specification remains unchanged and they cannot address the technical validity of the type or frequency of checks/tests.

The validity of the type and frequency of checks/tests conducted during production and on the final product shall be considered. This will include the checks conducted during manufacture on properties that cannot be inspected at a later stage and for checks on the final product. These will normally include:

Membrane:

Checks on incoming materials:

Supplier's certificate of conformity possibly including tests and/or combined with a simple material related test, e.g. penetration test for bitumen. Frequency: Each batch.

Checks on process:

Process parameters, e.g. thickness, width and monitoring of speed and temperature, shall be included in the FPC. Frequency: At least at the beginning, the middle and the end of every shift.

Checks on finished products:

Test plan according to EN 13707 or EN 13956 where relevant. If the membrane is CE marked this test plan is assumed to be carried out.

Some of the above mentioned tests on finished products may not be necessary for certain applications.

Insulation materials:

Checks on incoming materials:

Supplier's declaration of conformity/certificate of conformity

Checks on process:

Supplier's declaration of conformity/certificate of conformity.

Checks on finished products:

Further to the test plan required by the CE marking of the insulation material:

Point load and compression behaviour

Thermal properties if these are not part of the CE marking.

Where materials/components are not manufactured and tested by the supplier in accordance with agreed methods, then where appropriate they shall be subject to suitable checks/tests by the manufacturer before acceptance.

Fasteners:

See annex D

8.4 CE MARKING AND INFORMATION

The ETA shall indicate the information to accompany the CE marking (see below) and the placement of CE marking and the accompanying information (the kit/components itself/themselves, an attached label, the packaging, or the accompanying commercial documents).

- name or identifying mark of the producer
- last two digits of the year in which the marking was affixed
- number of the ETA (valid as indications to identify the characteristics of the mechanically fastened flexible roof waterproofing system and the characteristics where the "no performance determined" approach is used)
- Number of ETAG
- Number of FPC certificate.

Section Four: ETA CONTENT

9. THE ETA CONTENT

9.1 THE ETA CONTENT FOR THE KIT

The format of the ETA shall be based on the Commission Decision of 1997-07-22, EC Official Journal L236 of 1997-08-27.

The ETA shall specify the kits/components covered by the ETA (type of membrane, type of fastener, possibly type of insulation, vapour control layers etc.) and basic requirements for the substrate (see art. 7.1). The ETA shall also state that on site pull out tests can be performed if there is doubt concerning the suitability of the substrate.

The technical part of the ETA shall contain the information listed hereafter. The ETA shall either give the appropriate indication, classification, statement or description or - where relevant – indicate the “no performance determined” option. The items are given with reference to the relevant clauses of this Guideline:

Information on the performance of the kit:

- Type of approval, kit or component (clause 2.2)
- declaration of the assumed working life (clause 4)
- Classification of the kit with respect to external fire performance (clause 6.1.2.1)
- Statement on the content and/or release or otherwise of dangerous substances (clause 6.1.3.1). The ETA shall include the following text in the clause of dangerous substances:

According to the chemical constitution and composition of the components of the kit or the written declaration on dangerous substances (*whichever applies*) submitted by the ETA-holder to the Approval Body:

(...)³

In addition to the specific clauses relating to dangerous substances contained in this European Technical Approval, there may be other requirements applicable to the kit falling within its scope (e.g. transposed European legislation and national laws, regulations and administrative provisions). In order to meet the provisions of the EU Construction Products Directive, these requirements need also to be complied with, when and where they apply.

Note: For dangerous substances falling under the scope of the CPD for which

- no assessment and verification methods are given (or cannot be found in TR 034)
or
 - “no performance determined” is declared
or
 - the chosen verification and assessment method does not comply with the regulatory requirement of a particular Member State
- there might be the necessity for an additional assessment.

- declaration of the performance characteristics with respect to wind uplift (clause 6.1.4.1)
- declaration of the calculated or tested thermal resistance of the kit (clause 6.4.6.1)

³ For the expression of the assessment results on dangerous substances in the ETA, the Approval Bodies will follow the provisions given in Annex 1 to the Addendum to EOTA GD 001, March 2012, “Criteria for the ETA content of dangerous substances information”

Information on the components:

- declaration of the performance characteristics of the membrane with respect to:
 - Reaction to fire (6.2.2.1) peel (clause 6.2.3.1)
 - shear (clause 6.2.3.2)
 - tear (clause 6.2.3.3)
 - cold bending/folding (clause 6.2.3.4)
 - water pressure (clause 6.2.3.5)
 - water vapour permeability (clause 6.2.3.6)
 - tensile properties (clause 6.2.3.7)
 - static and dynamic indentation (clause 6.2.3.8)
 - dimensional stability (6.2.3.9)
- declaration of the resistance to ageing of the membrane (clauses 6.2.7.1 - 6.2.7.5)
- declaration of the performance characteristics of the fastener with respect to:
 - pull-out (Annex D)
 - resistance of the sleeve (Annex D)
 - Indication of the resistance to corrosion of the fastener (Annex D)
 - Indication of the resistance to heat ageing of plastic fasteners (Annex D)
- declaration of the performance characteristics of the insulation with respect to:
 - Reaction to fire (6.4.2.1) Compressibility of insulating panels (clause 6.4.3.1)

Information on the design:

- Principle sketches:
 - type of mechanical fastening of membranes
 - type of arranging of fasteners at upstands and penetrations
- Membrane:
 - seam overlap according to detailing
- Fastening:
 - design of fastener spacing and areas according to national requirements
 - spacing of fasteners (according to kind of fastening)
 - minimum distance in row
 - maximum distance in row
 - distance of the washer to the seam edge
 - design of perimeter and edge fixation
 - fastener spacings at upstands and penetrations
 - fastening system and fastener spacings
 - linear fastening
 - with coated metal
 - with metal trim / -profile
 - spot fastening (linear fastening)
 - spot fastening in row and in seam overlap
 - spot fastening with cover strips
 - fastening with support construction, e.g. timber beam
- Insulation:
 - fixing of the insulation
- Design principles of upstands and flashings, e.g.
 - height of upstand
 - fastening
 - entire flashing area
 - intermediate fixations
 - support constructions
 - upper edge of flashings / upstands
 - air-tight roofing membrane / vapour barrier

- Design principles of penetrations fastening of installed parts / units

The ETA may include annotated drawings with the dimensions marked and drawn to an adequate scale. The drawings shall be accompanied by a description of particular installation details.

9.2 THE ETA CONTENT FOR THE FASTENER

The ETA shall specify the fasteners covered by the ETA and basic requirements for the substrate (see art. 7.1). The ETA shall also state that on site pull out tests can be performed if there is doubt concerning the suitability of the substrate, see annex D.6:

9.3 ADDITIONAL INFORMATION

It shall be stated in the ETA that the manufacturer's installation guide forms part of the ETA, see 7.1.

Similarly, it shall be stated in the ETA whether or not any additional information (possibly confidential) shall be supplied to the approved body for the evaluation of attestation of conformity, see 8.3 of this Guideline.

Annex A

A. List of reference documents

Updating conditions:

The edition of a reference document given in this list is that which has been adopted by EOTA for its specific use.

When a new edition becomes available, this supersedes the edition mentioned in the list only when EOTA has verified or re-established its compatibility with the ETAG.

Unless noted otherwise all standards are undated signifying that the latest version of the standard shall be used.

Council Directive 89/106/EEC (CPD) 21 December 1988 – O.J. L40 – 11 February 1989

EN 13501-5	Fire classification of construction products and building elements - Part 5: Classification using data from external fire exposure to roofs tests
EN 13501-1	Fire classification of construction products and building elements - Part 1: Classification using test data from reaction to fire tests
EN 206	Concrete – performance, production, placing and compliance criteria
EN 636	Plywood. Specifications
EN 10346	Continuously hot-dip zinc coated structural steel sheet and strip – technical delivery conditions
EN 12316-1	Flexible sheets for roofing – Determination of peel resistance of joints – Part 1: Bitumen sheets
EN 12316-2	Flexible sheets for roofing – Determination of peel resistance of joints – Part 2: Plastic and rubber sheets
EN 12317-1	Flexible sheets for roofing – Determination of shear resistance of joints – Part 1: Bitumen sheets
EN 12317-2	Flexible sheets for roofing – Determination of shear resistance of joints – Part 2: Plastic and rubber sheets
EN 12310-1	Flexible sheets for roofing – Determination of nail shank tear resistance – Part 1: Bitumen sheets
EN 12112-2	Flexible sheets for waterproofing – Determination of tear properties – Part 2: Thermoplastic and elastomeric sheets
EN 1109	Flexible sheets for roofing – Bitumen sheets – Determination of flexibility at low temperature
EN 495-5	Thermoplastic and elastomeric roofing and sealing sheets; low temperature folding test
EN 1928	Flexible sheets for waterproofing – Determination of water tightness
EN 1931	Flexible sheets for waterproofing – Determination of water vapour transmission properties

EN 12311-1	Flexible sheets for roofing – Determination of tensile properties – Part 1: Bitumen sheets
EN 12311-2	Flexible sheets for roofing – Determination of tensile properties – Part 2: Plastic and rubber sheets
EN 1844	Elastomeric and thermoplastic sheets for waterproofing – Determination of resistance to ozone cracking
EN 1847	Elastomeric and thermoplastic sheets for waterproofing – Method of exposure to liquid chemicals including water
EN 12730	Flexible sheets for roofing – Determination of resistance to static loading
EN 12691	Flexible sheets for waterproofing – Testing of roofing – Determination of resistance to impact loading
EN 1296	Flexible sheets for waterproofing – Bitumen, plastic and rubber sheets for roofing – Artificial ageing by long term exposure to elevated temperature
EN 1297	Flexible sheets for roofing; determination of resistance to UV and water ageing; part 1: bitumen sheeting
EN 12039	Flexible sheets for roofing – bitumen sheeting – Determination of loss of granules
EN 1107-1	Flexible sheets for roofing – Determination of dimensional stability; Part 1: Bitumen sheets
EN 1107-2	Flexible sheets for roofing – Determination of dimensional stability; Part 2: Plastic and rubber sheets
EN 1849-1	Flexible sheets for waterproofing - Determination of thickness and mass per unit area - Part 1: Bitumen sheets for roof waterproofing
EN 1849-2	Flexible sheets for waterproofing - Determination of thickness and mass per unit area - Part 2: Plastic and rubber sheets for roof waterproofing
EN 1110	Flexible sheets for waterproofing - Bitumen sheets for roof waterproofing - Determination of flow resistance at elevated temperature
EN 1297	Flexible Sheets for waterproofing – Bitumen, plastic and rubber sheets for roof waterproofing – Method of artificial ageing by long term exposure to the combination of UV radiation, elevated temperature and water
EN/ISO 6946	Building components and building elements – Thermal resistance and thermal transmittance – Calculation method.
EN/ISO 8990	Thermal insulation – Determination of steady-state thermal transmission properties – calibrated and guarded hot box
EN 12667	Building materials – Determination of thermal resistance by means of guarded hot plate and heat flow meter methods – Products of high and medium thermal resistance
EN 12939	Building materials – Determination of thermal resistance by means of

	guarded hot plate and heat flow meter methods – Thick products of high and medium thermal resistance
EN/ISO 10211-1	Thermal bridges in building construction – Heat flows and surface temperatures – Part 1: General calculation methods.
ISO 6988	Testing in alternating atmosphere containing sulphur dioxide
EN 10088-1	Stainless steel – Part 1: List of stainless steels
DIN 50018	Prüfung im Kondenswasser – Wechselklima mit schwefel-dioxidhaltiger Atmosphäre
EN 826	Thermal insulation products for building applications – Determination of compression behaviour
EN 12430	Thermal insulation products for building applications – Determination of behaviour under point load
CONSTRUCT 95/148 – Rev. 1	Working Document on Dangerous Substances and in accordance with CONSTRUCT 97/219 – Rev. 1 Guidance paper on the Treatment of Dangerous Substances under Construction Products Directive
EOTA Guidance Document for the Assessment of Working Life of Products, Final draft, March 1997	
EOTA Technical Report no. 10	Liquid Applied Roof Waterproofing Kits (LARWK) – Exposure procedure for artificial ageing
EOTA Technical Report no. 34	General ER 3 Checklist for ETAGs/CUAPs/ETAs-Content and/or release of dangerous substances in products/kits
Construct 97/223 – Rev. 1	Mandate to EOTA for Systems of mechanically fastened flexible roof waterproofing membranes
EN 13707	Flexible sheets for waterproofing – reinforced bitumen sheets for roof waterproofing – Definitions and characteristics
EN 13956	Flexible sheets for waterproofing – Plastic and rubber sheets for roof waterproofing – Definitions and characteristics
EN 10204	Metallic products – types of inspection documents
ISO 1183	Methods for determining the density and relative density (specific gravity) of plastics excluding cellular plastics
EC Guidance Paper C	The Treatment of Kits and Systems under the Construction Products Directive
EC Guidance Paper D	CE Marking under the Construction Products Directive
EC Guidance Paper E	Levels and Classes in the Construction Products Directive
SS 92 35 15 (2)	Methods for determination of the coefficients of friction of various materials with respect to slipping (Swedish standard)
EN 12310-2	Flexible sheets for waterproofing - Determination of resistance to tearing - Part 2: Plastic and rubber sheets for roof waterproofing

EN 10346	Continuously hot-dip coated steel flat products - Technical delivery conditions
EN 1990	Eurocode - Basis of structural design
EN ISO 9001	Quality management systems - Requirements
EN ISO 3167	Plastics - Multipurpose test specimens
EN 16002	Flexible sheets for waterproofing - Determination of the resistance to wind load of mechanically fastened flexible sheets for roof waterproofing

Annex B

B COMMON TERMINOLOGY AND ABBREVIATIONS

B.1 Works and products

B.1.1 *Construction works (and parts of works)* (often simply referred to as “works”) (ID1.3.1)

Everything that is constructed or results from construction operations and is fixed to the ground. (This covers both building and civil engineering works, and both structural and non-structural elements).

B.1.2 *Construction products* (often simply referred to as “products”) (ID 1.3.2)

Products manufactured for incorporation in a permanent manner in the works and placed as such on the market. (The term includes materials, elements and components of prefabricated systems or installations.)

B.1.3 *Incorporation* (of products in works) (ID 1.3.1)

Incorporation of a product in a permanent manner in the works means that:

- its removal reduces the performance capabilities of the works, and
- that the dismantling or the replacement of the product are operations involving construction activities.

B.1.4 *Intended use* (ID 1.3.4)

Role(s) that the product is intended to play in the fulfilment of the essential requirements.

B.1.5 *Execution* (ETAG-format)

Used in this document to cover all types of incorporation techniques, such as installation, assembling, incorporation, etc.

B.1.6 *Kit*

Construction product for which the ETA holder takes responsibility consisting of at least two separate components that need to be put together to be installed permanently in the works. The components may or may not be bought from one single supplier

B.2 Performances

B.2.1 *Fitness for intended use* (of products) (CPD 2.1)

Products have such characteristics that the works in which they are intended to be incorporated, assembled, applied or installed, can, if properly designed and built, satisfy the essential requirements.

B.2.2 *Serviceability* (of works)

Ability of the works to fulfil their intended use and in particular the essential requirements relevant for this use.

The products shall be suitable for construction works which (as a whole and in their separate parts) are fit for their intended use, subject to normal maintenance. The requirements shall be satisfied for

an economically reasonable working life. The requirements generally concern foreseeable actions (CPD Annex I, Preamble).

B.2.3 **Essential requirements (for works)**

Requirements applicable to works, which may influence the technical characteristics of a product, and are set out in terms of objectives in the CPD, Annex I (CPD, art. 3.1).

B.2.4 **Performance** (of works, parts of works or products) (ID 1.3.7)

The quantitative expression (value, grade, class or level) of the behaviour of the works, parts of works or of the products, for an action to which it is subject or which it generates under the intended service conditions (works or parts of works) or intended use conditions (products).

B.2.5 **Actions** (on works or parts of the works) (ID 1.3.6)

Service conditions of the works which may affect the compliance of the works with the essential requirements of the Directive and which are brought about by agents (mechanical, chemical, biological, thermal or electro-magnetic) acting on the works or parts of the works.

B.2.6 **Classes or levels (for essential requirements and for related product performances)** (ID 1.2.1)

A classification of product performance(s) expressed as a range of requirement levels of the works, determined in the ID's or according to the procedure provided for in art. 20.2a of the CPD.

B.3 **ETAG-format**

B.3.1 **Requirements** (for works) (ETAG-format 4)

Expression and application, in more detail and in terms applicable to the scope of the guideline, of the relevant requirements of the CPD (given concrete form in the ID's and further specified in the mandate, for works or parts of the works, taking into account the durability and serviceability of the works.

B.3.2 **Methods of verification** (for products) (ETAG-format 5)

Verification methods used to determine the performance of the products in relation to the requirements for the works (calculations, tests, engineering knowledge, evaluation of site experience, etc.)

B.3.3 **Specifications** (for products) (ETAG-format 6)

Transposition of the requirements into precise and measurable (as far as possible and proportional to the importance of the risk) or qualitative terms, related to the products and their intended use.

B.4 **Working life**

B.4.1 **Working life** (of works or parts of the works) (ID 1.3.5(1))

The period of time during which the performance will be maintained at a level compatible with the fulfilment of the essential requirements.

B.4.2 **Working life** (of products)

Period of time during which the performances of the product are maintained - under the corresponding service conditions - at a level compatible with the intended use conditions.

B.4.3 ***Economically reasonable working life*** (ID 1.3.5(2))

Working life which takes into account all relevant aspects, such as costs of design, construction and use, costs arising from hindrance of use, risks and consequences of failure of the works during its working life and cost of insurance covering these risks, planned partial renewal, costs of inspections, maintenance, care and repair, costs of operation and administration, of disposal and environmental aspects.

B.4.4 ***Maintenance*** (of works) (ID 1.3.3(1))

A set of preventive and other measures which are applied to the works in order to enable the works to fulfil all its functions during its working life. These measures include cleaning, servicing, repainting, repairing, replacing parts of the works where needed, etc.

B.4.5 ***Normal maintenance*** (of works) (ID 1.3.3(2))

Maintenance, normally including inspections, which occurs at a time when the cost of the intervention which has to be made is not disproportionate to the value of the part of the work concerned, consequential costs (e.g. exploitation) being taken into account.

B.4.6 ***Durability*** (of products)

Ability of the product to contribute to the working life of the work by maintaining its performances, under the corresponding service conditions, at a level compatible with the fulfilment of the essential requirements by the works.

B.5 **Approval and Approved Bodies**

B.5.1 **Approval Body**

Body notified in accordance with Article 10 of the CPD, by an EU Member State or by an EFTA State (contracting party to the EEA Agreement), to issue European Technical Approvals in (a) specific construction product area(s). All such bodies are required to be members of the European Organisation for Technical Approvals (EOTA), set up in accordance with Annex II.2 of the CPD.

B.5.2 **Notified Body**

Body nominated in accordance with Article 18 of the CPD, by an EU Member State or by an EFTA State (contracting party to the EEA Agreement), to perform specific tasks in the framework of the Attestation of Conformity decision for specific construction products (certification, inspection or testing). All such bodies are automatically members of the Group of Notified Bodies.

B.6 **Abbreviations**

B.6.1 ***Abbreviations concerning the Construction products directive***

AC: Attestation of conformity
CEC: Commission of the European Communities
CEN: Comité européen de normalisation (European Committee for Standardization)
CPD: Construction products directive
EC: European community
EFTA: European free trade association
EN: European Standards
ER : Essential Requirements
FPC: Factory production control
ID: Interpretative documents of the CPD
ISO: International standardisation organisation
SCC: Standing committee for construction of the EC.

B.6.2 **Abbreviations concerning approval:**

EOTA: European organisation for technical approvals
ETA: European technical approval
ETAG: European technical approval guideline
TB: EOTA Technical Board
UEAtc: Union Européenne pour l'Agrément technique dans la construction (European Union of Agreement).

B.6.3 **General abbreviations:**

WG: Working group.

Annex C

Site pullout test.

The following is a recommendation for the carrying out of an on site pullout test.

Purpose of test

The site pullout test is used to confirm the behaviour and ultimate pullout load at failure of the fastener. This is then divided by a safety factor to give the admissible (design) pullout load for that specific fastener type into that specific substrate on a given project.

Equipment

Although many variations are in use, a basic pullout test unit will comprise (see figure C1):

C.1 Base plate

Supports the unit on the roof surface.
Shall have a reasonable surface area.

C.2 Pulling plate/jaw

Fits under the head of the fastener.
Due to the wide range of fastener types it often has interchangeable inserts for different shank diameters or threaded collars for testing studding etc.

C.3 Tensioning device

Usually a threaded high tensile steel screw and handle.

C.4 Measuring scale/gauge

Usually hydraulic and measures the force applied by the tensioning screw. The test unit shall be calibrated frequently.

Method

Pullout testing requires a fixing with sufficient space beneath the head to insert the pulling plate. On a new build project or a refurbishment project involving new mechanical fixings, a partially driven fixing would be used. Any roofing material (e.g. membrane, existing insulation) that may influence the pullout values shall be removed before the test is performed. The fastener shall be installed using the same method as will be used during actual construction (i.e. depth of installation, hole diameter, installation tools).

A minimum of six samples per 5000 m² roof shall be tested. The tests shall be performed across the roof in various areas including corners and the perimeter, to provide a good cross section example of performance. The location of the tests shall allow for 50 % more tests in the corner and perimeter. Any area that is likely to have deck damage due to leaks shall be tested.

A sketch indicating the location of the pullout tests shall be available.

C.5 Procedure

- The correct insert or collar for the fixing to be tested is selected and fitted it into the pulling plate.
- If different indicator gauges are available the most suitable is selected and the Maximum Load indicator is set to zero.
- The testing unit is located over the fixing and the pulling plate insert is slid beneath to engage the head of the fixing.
- The load is applied to the fastener by slowly turning the tensioning handle and the Current and Maximum Load

needles are observed. The load is applied gradually, and the needle behaviour is noted until the Current Load needle starts to fall away.

- The travelling Maximum Load indicator will remain at the highest position to identify the maximum pullout figure
- The tension is gradually released and the pulling plate is returned to its flush starting position and withdrawn from the fixing.

Treatment of results

The admissible (design) pullout load is calculated from the following formula:

$$F_{adm} = X/v$$

- Where
- F_{adm} = admissible (design) load per fastener
 - X = mean value of all pullout tests
 - v = safety factor
 - 2,0 for steel decks
 - 2,5 for wood and aluminium decks
 - 3,0 for all concrete decks (poured, thin slabs, lightweight etc.)

For design purposes the lowest of either W_{adm} derived from full scale or small scale testing according to this Guideline or F_{adm} from the on site pullout test is to be used.

F_{adm} derived at building sites reflects only the pullout performance of the fastener and does not take into account other failure modes such as washer deformation or membrane tearing. Therefore, a value higher than W_{adm} determined according to this Guideline may never be used.

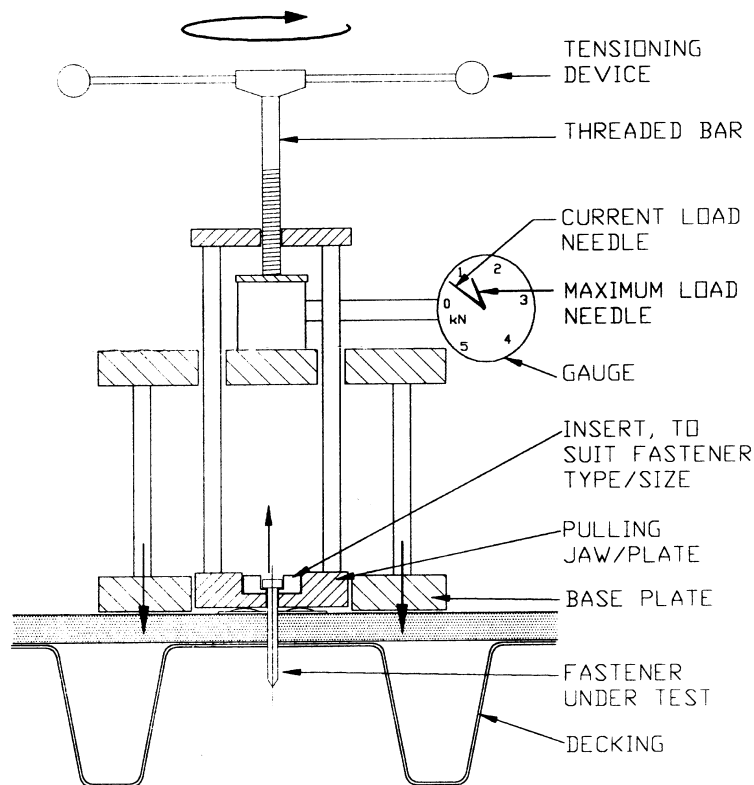

Figure C.1. Principle of on site pullout test

Annex D

Procedure to issue ETAs for fasteners for mechanically fastened roof waterproofing kits

Introduction

The present situation on the market place is such that very few kits in the strict sense of the definition of a kit are brought to the market. In order to establish the basis for issuing ETA for kits of mechanically fastened flexible roof waterproofing membranes, it has been determined that there is a need for the possibility for fastener manufacturers to obtain an ETA for the fasteners, which can form the basis for evaluation and assessment of the whole kit. The main purpose is to limit repetition of testing and assessments of fasteners.

D. 1. Scope

The purpose of this Annex is to establish a common basis for the issue of component ETA's for fasteners for mechanically fastened flexible roof waterproofing membranes according to ETAG 006.

This Annex describes the test and assessment methods necessary to issue a component ETA for fasteners based on ETAG 006 and it describes the provisions concerning evaluation of conformity to be implemented by the fastener manufacturers applying for an ETA for fasteners.

The following approaches solely relate to mechanical fasteners consisting of a screw and, plate or washer/sleeve element.

The following fixing systems are excluded from this annex:

- Clout nails used to fix bituminous membranes
- A powder actuated fastener which is covered by an existing CUAP which assesses its suitability for use in a roofing kit does not require assessment to the provisions of this annex.

D. 2. Test methods

The assessment of the fasteners for a component ETA is described below. Necessary supplementary testing in case of changes to the fasteners is described in chapter 4.

Tests required are:

- Axial loading,
- Resistance to unwinding,
- Mechanical resistance/brittleness of the plastic fastener,
- Corrosion resistance.

D. 2.1 Axial loading test

D. 2.1.1 Test method

This test method determines the axial failure of a fastener under static loading, irrespective of the failure mode.

Test apparatus

Test machine which can be operated with static tensile forces.

Load cell to measure the force.

Deformation gauge

Holding device for the substrate

Device for applying the force to the fastener. See principle in Figure D 1.

Test specimen

Plastic sleeves are stored for two weeks in the testing laboratory at $23 \pm 2^\circ\text{C}$ and $50 \pm 5\%$ RH.

The fasteners shall be installed in the specified substrate according to the manufacturer's installation guide.

The substrates used in the test are defined in art. 5.1.4.1 of ETAG 006.

The test is performed at $23 \pm 2^\circ\text{C}$, $50 \pm 5\%$ RH.

Procedure

The fastener and substrate are secured in the test machine in such a manner that any effects of bending are as far as possible avoided. The machine shall be operated at a speed of 5 - 10 mm/min.

10 specimens of fastener and substrate are tested.

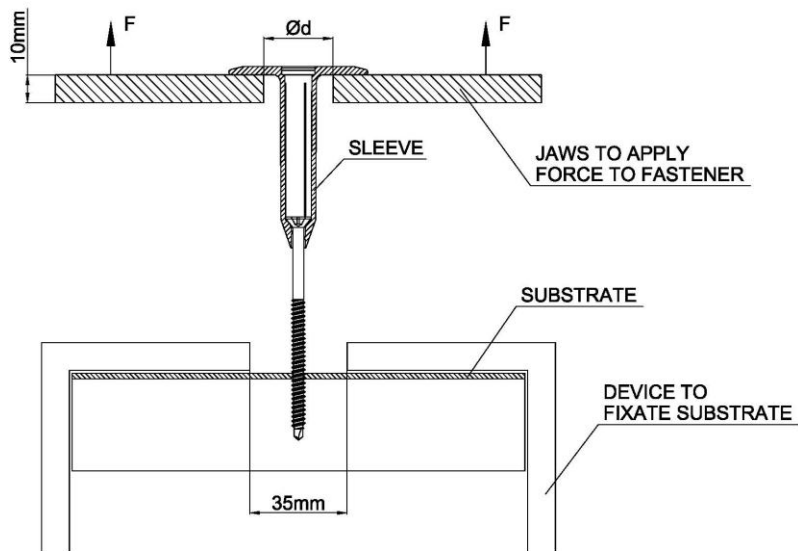

Figure D. 1. Principle of axial loading test

D. 2.1.2 Evaluation of test results

D. 2.1.2.1 General

The failure load of the fastener is found for each specimen. The mean value as well as the 5%-fractile are determined according to EN 1990 and the failure mode is noted. The 5%-fractile multiplied by a correction factor α is the characteristic value of the mechanical resistance (tension resistance) R_k of the fastener.

D. 2.1.2.2 Metal substrates

In order to determine the mean value and the 5%-fractile the single test results shall be multiplied by a correction factor α which depends on the failure mode:

Pull out failure:

$$\alpha = (R_m/R_{m,\text{test}}) \cdot (t_N/t_{\text{test}}) \leq 1,0$$

R_m = tensile strength of the metal substrate according to technical delivery condition

$R_{m,\text{test}}$ = tensile strength of the metal substrate used for the test

t_N = nominal core thickness of the metal substrate

t_{test} = core thickness of the metal substrate used for the test

Other failure modes:

$$\alpha = 1,0$$

D. 2.1.2.3 Concrete substrates

In order to determine the mean value and the 5%-fractile the single test results shall be multiplied by a correction factor α which depends on the failure mode.

Pull out failure of metallic anchors:

α shall be determined according to ETAG 001, chapter 6.0, as follows:

$$\alpha = (f_c/f_{c,\text{test}})^{0,5} \leq 1,0$$

f_c = nominal compression strength of the concrete

$f_{c,\text{test}}$ = compression strength of the concrete used for the test

Other failure modes and pull out failure of plastic anchors:

$$\alpha = 1,0$$

D. 2.1.2.4 Aerated concrete substrates

In order to determine the mean value and the 5%-fractile the single test results shall be multiplied by a correction factor α which depends on the failure mode.

Pull out failure:

α shall be determined as follows:

$$\alpha = (\rho^{3/4} f_c) / (\rho_{\text{test}}^{3/4} f_{c,\text{test}}) \leq 1,0$$

f_c = nominal compression strength of the aerated concrete in dry condition

$f_{c,\text{test}}$ = compression strength of the aerated concrete used for the test in dry condition

ρ = nominal density of the aerated concrete in dry condition

ρ_{test} = density of the aerated concrete used for the test in dry condition

Other failure modes:

$$\alpha = 1,0$$

D. 2.1.2.5 Timber substrates

In order to determine the mean value and the 5%-fractile the single test results shall be multiplied by a correction factor α which depends on the failure mode

Pull out failure:

$$\alpha = \rho / \rho_{\text{test}} \leq 1,0$$

ρ = nominal density of the timber

ρ_{test} = density of the timber used for the test

Other failure modes:

$$\alpha = 1,0$$

D. 2.2 Testing of resistance to unwinding (not relevant for linear fasteners)

D. 2.2.1 Test method

This test method defines the conditions for testing the unwinding resistance of the mechanical fasteners. The test is only relevant for fasteners fixed onto metal decks. The test relates to coupling mechanisms (fastener plus washers) intended to secure the roof waterproofing membrane, laid over an insulation, onto galvanised steel sheet.

For kits where the unwinding susceptibility of the fastener is known based on existing test and/or field experience the test is not necessary.

The test is performed with a bituminous membrane reinforced with polyester 180 g/m² (thickness of membrane: 4 mm).

The test can also be used to assess the effect any changes in the fastener design may have e.g. change in drill point diameter and thread geometry.

This test can also be performed with supports other than those envisaged in the following.

Principle of test:

The test involves subjecting an assembled specimen to the effects of alternating loads simulating the effect of wind induced ripples across the sheet in order to assess the likelihood of it unwinding.

Equipment:

Test apparatus as shown in Figure **D. 2**.

- Mechanical screwdriver with adapted bit
- Galvanised steel deck 0,7 mm, specifications min. S280 according to EN 10346
- bituminous membrane with polyester reinforcement 180 g/m² (thickness of membrane: 4 mm)
- Mineral wool insulation having a density of 150 kg/m³ ± 10 %, and a nominal thickness of 50 mm.
Dimensions: 300 mm x 250 mm (300 mm perpendicular to the direction of manufacture)

Test apparatus:

- | | |
|----------------------------|---|
| 1. Washer | 2. Bituminous membrane with polyester reinforcement |
| 3. Fastener | 4. Galvanised steel sheet |
| 5. Loading mechanism | 6. Mobile arm |
| 7. Insulating panel | 8. Dual action jack |
| 9. Test sample (plan view) | |

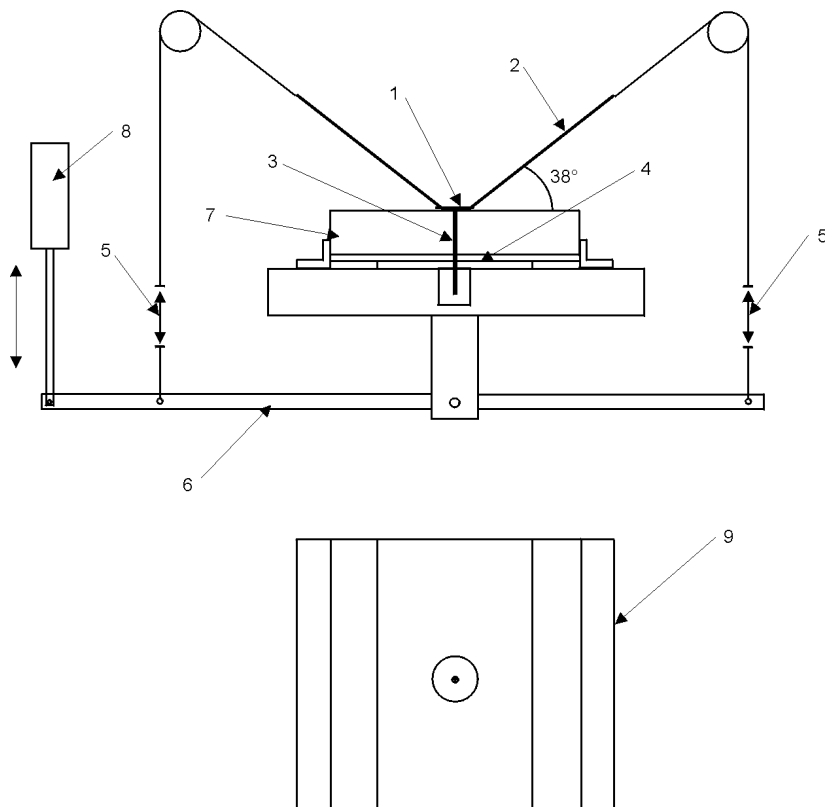

Figure D. 2. Test apparatus for unwinding test

Principles of test:

A dual action pneumatic jack equipped with adjustable limit switches activates an arm pivoted about a rigidly fixed axis.

This oscillating arm transmits alternating tensile loads to the roof waterproofing membrane (via the loading mechanism and cables) which then transmits these loads to the coupling.

A raked tensile angle of 38° is achieved via suitable positioned pulleys.

The loading mechanism limits the force to which the coupling will be subjected.

Cycle frequency: 90 ± 5 cycles per minute.

Number of cycles: 900. The test can be terminated when unwinding has taken place.

Preliminary adjustments:

- The mobile arm is positioned horizontally and the length of the cables are adjusted such that the load corresponds to a force of 0,1 kN.
- The jack limit switches are adjusted such that when the arm is at maximum inclination (in either direction) the extension of one loading mechanism corresponds to a force of 0,2 kN, the other loading mechanism is relaxed (i.e. zero load)

Procedure

Place the metal sheet into its housing, then position the specimen of insulation and the sample of roof waterproofing membrane centrally over the metal sheet.

Install the coupling at the centre of the sample using a mechanical screwdriver. Do not fully tighten the fastener. Use a manual screwdriver to finish tightening the fastener until the washer is flush with the surface of the waterproofing membrane (+0,-1 mm). If the fastener has an oblong washer the longitudinal axis shall be perpendicular to the direction of movement.

Using a fine felt-tipped pen, make a reference mark on the fastener head, washer and membrane in order to monitor the relative movement of the fastener head (possibly also of the washer) relative to the membrane.

Clamp the sample symmetrically onto the sheet and zero the test apparatus (0,1 kN on either side).

Commence the alternate mechanical cycles.

Note the number of cycles after rotation of the fastener head, i.e. $\frac{1}{4}$ and $\frac{1}{2}$ turn.

Repeat the test in the same way on 9 other samples.

D. 2.2.2 Requirements and evaluation of test results

All fasteners shall meet the requirements specified below.

For each fastener:

- Indicate the rotation made by the fastener head after 500 cycles. The rotation of the fastener head shall be less than or equal to $\frac{1}{4}$ turn.
- Indicate the rotation made by the fastener head after 900 cycles (end of test). The rotation of the fastener head shall be less than or equal to $\frac{1}{2}$ turn.
- Indicate any vertical movement made by the fastener head after 900 cycles. Allowing for the pitch of the fastener thread, the calculated vertical displacement shall be less than or equal to 1 mm per fastener turn.

D. 2.3 Mechanical resistance/brittleness of the plastic fastener

D. 2.3.1 Test method

This method is intended to test the impact resistance and brittleness of the plastic fastener before and after ageing.

The top edge of the washer is struck by a cylindrical drop weight at an angle of 45°. The angle of impact is obtained by placing the fastener in a special shoe.

The mechanical resistance of the washer is carried out according to:

EN 12691 Impact resistance

with the following amendments:

- The fasteners are stored for two weeks in the testing laboratory at $23 \pm 2^\circ\text{C}$ and $50 \pm 5\%$ RH
- The vacuum or pressure device is not needed
- The mass of the drop weight including the tool shall be $2,0 \pm 0,01$ kg
- The puncturing sphere is replaced by a $\varnothing 30$ mm cylindrical piston made of steel.
- The ballast ring and the expanded polystyrene panel is replaced by a wooden shoe to fix the fastener as shown in Figure 3. The fastener is fitted in the shoe and placed under the drop weight.
- The height is measured from the bottom edge of the puncturing tool to the top edge of the fastener in the shoe.
- The impact resistance is expressed as the drop height in mm which has not caused damage on the sleeve or washer of the fastener in any of the 5 specimens.

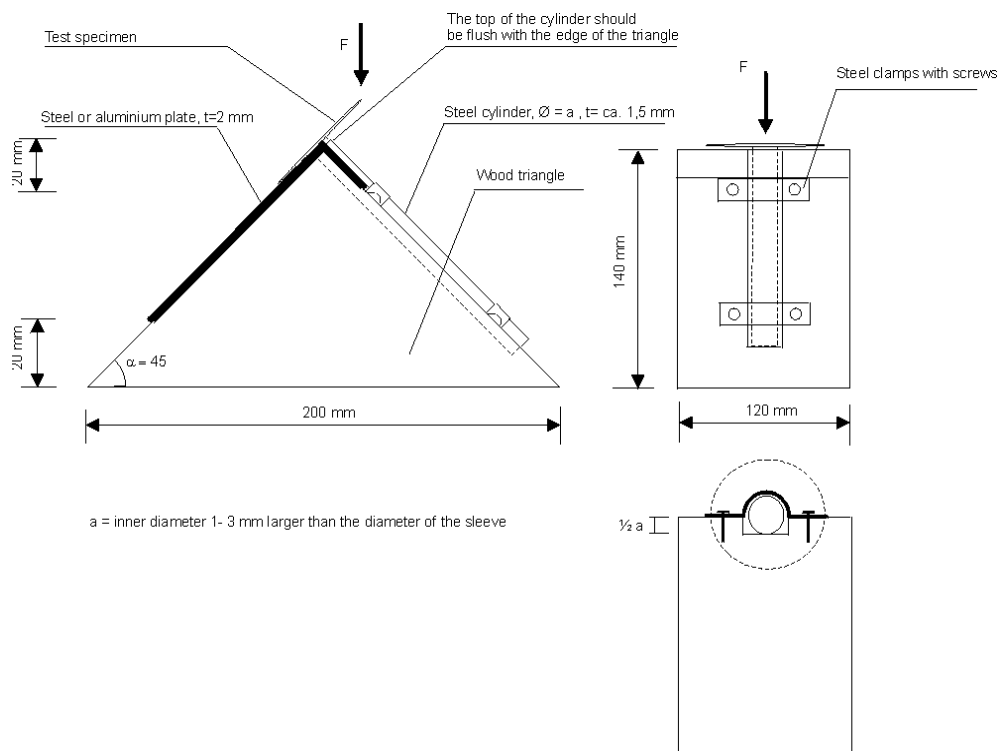

Figure D. 3: Test apparatus for impact test for plastic fasteners

D. 2.3.2 Requirements and evaluation of test results

Indication of drop height for new fasteners. The drop height shall be $\geq 1,0$ m.

D. 3. Aspects of durability

D. 3.1 Testing of resistance to corrosion of metallic fasteners

D. 3.1.1 Test method

The test described in this chapter shall be carried out on fasteners including metal parts unless they are made from materials which have been proven to be resistant to corrosion. Any fastener including metal components not composed of austenitic stainless steel according to EN 10088-1 shall be subjected to this test.

Determination of the corrosion behaviour of fasteners is made by testing in accordance with ISO 6988:1995 - Testing in alternating atmosphere containing sulphur dioxide - on a total of 10 fasteners.

The fasteners are to be incorporated into the roof system, as in practice, according to the specifications of the fastener manufacturer. The fasteners are installed in a substrate corresponding to the use of the fastener with a thermal insulation of expanded perlite or mineral wool with a density of at least 150 kg/m^3 and a thickness corresponding to the maximum clamping range of the fastener, unless the insulation forms part of the kit in which case the actual insulation is used. If the clamping range has no influence on the corrosion performance of the fastener, the thickness of the thermal insulation shall be 100 mm. This is not a model of the roof construction but a build up for testing purposes only. The length of the fastener which passes through or is embedded in the substrate shall be measured individually for each fastener and noted.

The fasteners are removed from the build up without causing further damage to the coating. This is facilitated by either cutting through the substrate and insulation, or - if unscrewing - ensuring that the fastener and washer are removed as a single item (i.e. that the screw thread does not spin in the washer)

The fasteners are subjected to either 2 or 7 or 15 exposure cycles in an alternating humid atmosphere containing 2 litres of sulphur dioxide, concentration SFW 2.0 S in accordance with DIN 50018:1997.

The test specimens are to be arranged centrally in the test chamber by suspending them vertically by the use of an inert thread, such as nylon, with a minimum spacing of 20 mm between them. Only test specimens of the same type are to be used for each test, to rule out test specimens with different corrosion protection systems affecting each other. Washers (in the case of point fasteners); profiles (in the case of linear fasteners); and fastener shafts are to be arranged in the test chamber separately from each other. In order to compensate for the small surface area of the fasteners a galvanised steel blanking plate shall be included to achieve the minimum surface test area of $0,5 \pm 0,1 \text{ m}^2$.

The test specimens are exposed to the effect of condensation from water to which 2 litres of sulphur dioxide (SO_2) has been added. The 2 litres of sulphur dioxide (SO_2) are charged immediately after the test chamber is closed. The heating is switched on to reach a test temperature of $40 \pm 3^\circ\text{C}$ in 95 ± 5 minutes. One cycle comprises two test stages and lasts for a total of 24 hours. In the first test stage, totalling 8 hours (after the heating is switched on), the test specimens are exposed at $40 \pm 3^\circ\text{C}$ to the condensation and the sulphur dioxide. The second test stage begins when the heating is switched off and the test chamber is opened or ventilated. The test specimens are to be left in the chamber, where drying will take place over 16 hours. After the second test stage, the base tank of the test chamber is emptied, cleaned, if necessary, and filled with fresh distilled or de-ionised water. The test chamber is closed and charged with sulphur dioxide. A new cycle begins when the heating is switched on.

When the 2 or 7 or 15 cycles have been completed, the test specimens are removed from the test chamber and examined for surface corrosion (rusting). Any corrosion which may have formed beneath the corrosion protection coating is also to be recorded. If it is clear that the requirements of 3.1.2 cannot be achieved before the 2, 7 or 15

cycles are completed, the result is considered unsatisfactory and the test may be terminated.

The head of the fastener and the part of the fastener which has passed through (metal) or is embedded in (concrete) the substrate, the rim around the external edges of the washer and profiles are not included in the determination of surface corrosion. Visual evaluation is made. In borderline cases, the evaluation shall be undertaken by 3 people, independently of each other.

D. 3.1.2 Requirements and evaluation of test results

Fasteners for use without restrictions on the risk of corrosion and condensation shall be made of materials which are deemed to satisfy the requirements on corrosion, e.g. fasteners made from austenitic stainless steel according to EN 10088-1.

Carbon steel fasteners shall have undergone an anti-corrosion treatment. In this respect, the moisture content of the material of the load-bearing structure and any condensation likely to occur shall be taken into account.

Carbon steel fasteners shall resist to 15 cycles (15% surface corrosion) with an exception of fasteners for bituminous multilayered systems (see figure 1 – d; g; h & i) where 2 cycles (0% surface corrosion) or 7 cycles (5% surface corrosion) can be accepted for buildings without humidity or condensation risks in the roof assembly and as long as it does not conflict with national provisions, provided that the use of the building does not change. The corrosion behaviour cycles are to be evaluated as follows:

- After 2 cycles with the test procedure in accordance with **D. 3.1.1**, the metallic parts of all tested fasteners shall not exhibit more than 0% surface corrosion (rust formation) or corrosion formation recognisable beneath the corrosion protection coating.
- After 7 cycles with the test procedure in accordance with **D. 3.1.1**, the metallic parts of all tested fasteners shall not exhibit more than 5% surface corrosion (rust formation) or corrosion formation recognisable beneath the corrosion protection coating.
- After 15 cycles with the test procedure in accordance with **D. 3.1.1**, the metallic parts of all tested fasteners shall not exhibit more than 15% surface corrosion (rust formation) or corrosion formation recognisable beneath the corrosion protection coating.

The number of cycles shall be stated in the ETA.

The Approval Body shall assess the acceptability of any corrosion below the surface layer and this shall be recorded in the ETA.

D. 3.2 Testing of mechanical resistance after heat ageing of plastic fasteners

D. 3.2.1 Test method

For plastic fasteners not exposed to UV or water, no assessment against these two factors is required. Where the fastener is exposed to either of these, an appropriate assessment method determined by the approval body shall be used

Plastic fasteners are tested as follows:

- Heat ageing of the plastic part of the fastener for 28 days at $80 \pm 2^\circ\text{C}$.
- Heat ageing of the charpy test specimen according to EN ISO 3167 for 28 days at $80 \pm 2^\circ\text{C}$.

Before and after ageing the plastic part of the fastener is submitted to testing as described in D. 2.3.1.

Before and after ageing the charpy test specimen is tested according to EN ISO 179-1.

D. 3.2.2 Requirements and evaluation of test results

Tests according to D. 2.3.1:

Indication of the drop height after ageing. The drop height shall be $\geq 1,0$ m.

Tests according to EN ISO 179-1:

The test results after ageing shall not deviate more than 20% from the test results before ageing.

D. 4. Supplementary tests in case of fastener modifications

Information about the necessary supplementary testing in case of fastener modifications is given in Table D.1. This simplified approach is only applicable if not more than one parameter affecting the mechanical resistance of the fastener is changed (e.g. washer or thread or drill point). For the number of the tests according to Figures D.1, D.4, D.5 and D.6 and the evaluation of the corresponding results the rules given in D.2.1 shall be applied. The characteristic value referring to the modified parameter is the mechanical resistance (tension resistance) $R_{k,N}$ of the modified fastener, provided that this characteristic value is lower than the characteristic value $R_{k,O}$ determined by the reference axial loading test ($R_{k,N}/R_{k,O} \leq 1,0$). Otherwise the characteristic value determined by the reference axial loading test is the relevant mechanical resistance (tension resistance) $R_{k,O}$.

The tests listed in Table D. 1 are not necessary if it is obvious that the modification of the relevant parameter improves the mechanical resistance of the fastener (e.g. modified washer is thicker than original washer of same material or modified material has higher material properties etc.).

Table D. 1 Modifications to fasteners and required tests

Changes to fastening elements	Test concept applicable						
	Washer pull-through test according to Fig. D.5 & D.6	Fastener pull- out test according to Fig. D.4	Axial loading test according to Fig. D.1	Corrosion test according to § D.3.1	Unwinding test according to § D.2.2	Mech. Res. & Brittleness according to § D.2.3	Influence on mechanical resistance of the fastener
Fastener							
Drill point or piercing point geometry	-	x	-	-	x	-	yes
Shank dimension	-	x ¹	-	-	-	-	yes
Head style	x	-	-	-	-	-	yes
Supporting threads	-	-	-	-	-	-	no
Change coating	-	-	-	x	-	-	no
Heat treatment specifications for steel parts	-	-	-	-	-	-	no
Material	-	x	-	x ²	-	-	yes
Length of the fastener	-	-	-	-	-	-	no
Thread geometry (thread pitch, inner- & outer diameter)	-	x	-	-	x	-	yes
Washer without integrated sleeve							
Washer outside dimensions, geometry and shape	x	-	-	-	-	-	yes
Washer thickness	x	-	-	-	-	-	yes

Washer strength, material specifications of metal	x	-	-	x²	-	-	yes
Washer coating	-	-	-	x	-	-	no
Dimple geometry, diameter	x	-	-	-	-	-	yes
Plastic materials	x	-	-	-	-	X	yes
Washer with integrated sleeve							
Plastic anchor expansion zone	-	-	x	-	-	-	yes
Plastic washer dimensions, geometry and shape	x	-	-	-	-	-	yes
Plastic materials	x	-	-	-	-	-	yes

1: Instead of pull-out tests, the tensile resistance of the shank can be calculated ($A_{Shank} \times f_{u,Shank}$); A_{Shank} = cross section of shank; $f_{u,Shank}$ = tensile strength of shank

2: Test is only required for change of austenitic stainless steel to carbon steel.

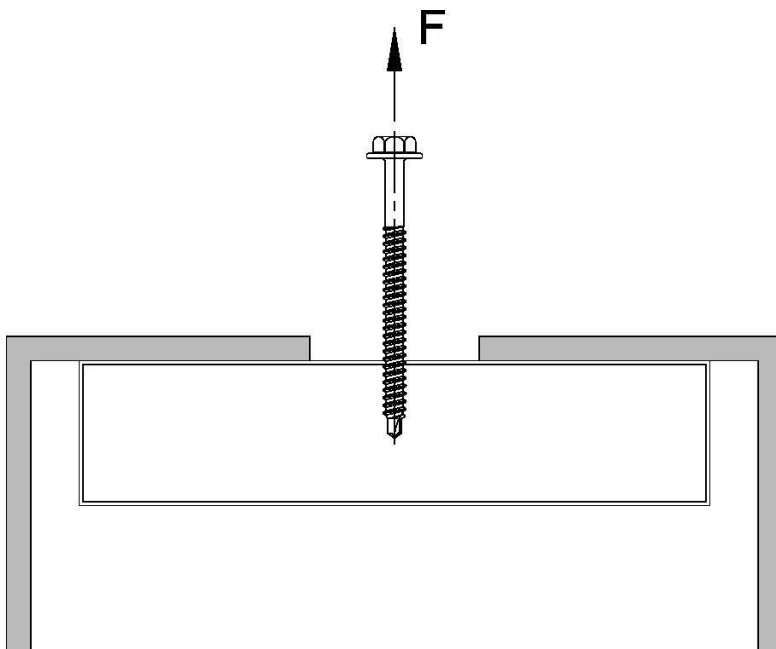

Figure D. 4: Principle of fastener pull-out test

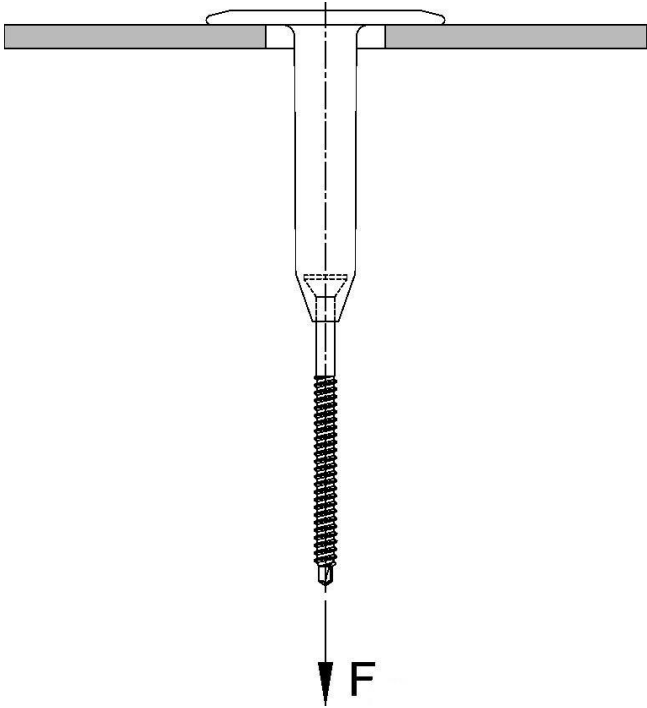

Figure D. 5: Principle of plastic washer pull-through test

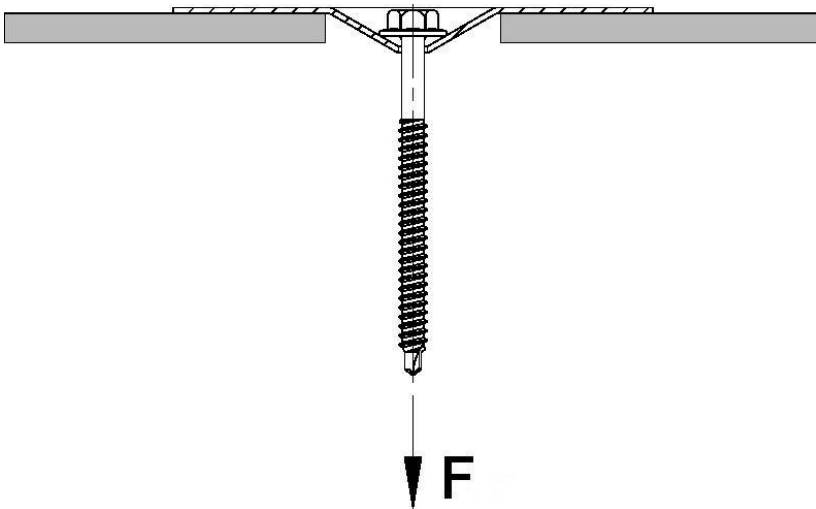

Figure D. 6: Principle of metallic washer pull-through test

D. 5. Evaluation of conformity

D. 5.1 General

The system of evaluation of conformity follows ETAG 006 and which is specified by the European Commission in mandate Construct 97/223 Annex 3 is system 2+ described in Council Directive (89/106/EEC) Annex III, 2(ii), First possibility and is detailed as follows:

Product	Intended use	Levels or classes	Attestation of conformity system
Fasteners for mechanically fastened flexible roof waterproofing membranes	For building works	-	2+

Table D.2 System of attestation of conformity applicable to fasteners for mechanically fastened flexible roof waterproofing membranes

System 2+:

Declaration of conformity of the product by the manufacturer on the basis of:
(See Annex III.2.(ii), first possibility, of the CPD):

- (a) Tasks for the manufacturer:
 - (1) Initial type–testing of the product;
 - (2) Factory production control;
 - (3) Testing of samples taken at the factory in accordance with a prescribed test plan.
- (b) Tasks for the notified body:
 - (4) Certification of factory production control on the basis of:
 - Initial inspection of factory and of factory production control;
 - Continuous surveillance, assessment and approval of factory production control.

D. 5.2 Tasks and responsibilities of manufacturer and notified bodies

In transposing the relevant systems of attestation of conformity to the approved product the approval body has to lay down the specific tasks of the manufacturer and the notified body (if relevant) in the process of attestation of conformity in control plans.

Both large and small companies produce these products and there is a wide variation in the materials and test methods used. Therefore a precise test plan can only be set up on a case-by-case basis.

In general it is not necessary to conduct tests on complete fasteners. Indirect methods will normally be sufficient, e.g. control of raw materials, manufacturing processes and properties of components.

The following gives general cornerstones on how to write these control plans for the product family of this Annex. They shall be specified and filled in by the approval body for the approved product under consideration of the specified production process of the manufacturer.

It is assumed that the characteristics given in following control plans have a correlation to the properties of the fasteners.

D. 5.2.1 Tasks of the manufacturer (Control plan)

Table D. 3 Tasks of the manufacturer

Type of control		Test or control method	Minimum extent/frequency of control
AoC element (acc. to CPD Annex III.1)	Product, raw/constituent material, product component and characteristic concerned		
Factory production control (including testing of samples in accordance with a prescribed test plan)	Identification of incoming materials	Suppliers certificate 3.1 according to EN 10204 for steel and plastic materials, including density according to ISO 1183 and Melt Flow Index (MFI) according to ISO 1183.	Every delivery
	<i>Checks on process:</i> Metal parts: Not applicable Plastic parts: Check the most important process parameters for plastic part manufacturing		per batch
	<i>Checks on finished products:</i> Check of <ul style="list-style-type: none"> • Dimensions • Geometry • Material properties • Coating 		per batch
Initial type test of the product	No tests necessary when the test leading to an ETA are done on products coming from the production process which is related with the ETA	-	-
	Identification of components		When starting the production process of the CE marked product or when starting a new production line

D. 5.2.1.1 Factory production control (FPC)

The manufacturer shall exercise permanent internal control of production. Elements are controlling of the production process including testing of materials before during and at the end of that process. All the elements, requirements and provisions adopted by the manufacturer shall be documented in a systematic manner in the form of written policies and procedures. This production control system shall ensure that the product is in conformity with the European Technical Approval (ETA).

Manufacturers having an FPC system which complies with EN ISO 9001 **and** which addresses the requirements of an ETA are recognised as satisfying the FPC requirements of the Directive.

D. 5.2.1.2 Testing of samples taken at the factory

These tests refer to finished product coming out of the production process. When the requirements of the FPC are fulfilled it is not necessary to have any more tests on samples taken at the factory.

D. 5.2.1.3 Initial Type Testing (ITT)

Approval tests will have been conducted by the approval body or under its responsibility (which may include a proportion conducted by a laboratory or by the manufacturer, witnessed by the approval body) in accordance with section 2 of ETAG 006. The approval body will have assessed the results of these tests in accordance with section 2 of ETAG 006, as part of the ETA issuing procedure.

These tests shall be used for the purposes of Initial Type Testing⁴ if they are done on samples coming from the current production process of the manufacturer which is referred to in the ETA. So further test are not necessary.

If the approval tests are done on samples e.g. of a prototype or if a new production line is started at the beginning of the of the new production process an additional ITT is necessary.

D. 5.2.1.4 Declaration of Conformity

When all the criteria of the Conformity Attestation on the basis of the tasks of the manufacturer and the tasks of the notified body (Certification) are satisfied the manufacturer shall make a Declaration of Conformity and has to assign the product with the CE-mark.

⁴In this respect Approval Bodies shall be able to have open arrangements with relevant Notified Bodies to avoid duplication, respecting each others responsibilities.

D. 5.2.2Tasks of the notified body (control plan)

Table **D.4:** Tasks of the notified body

Type of control		Test or control method	Minimum extent/frequency of control
AoC element (acc. to CPD Annex III.1)	Product, raw/constituent material, product component and characteristic concerned		
Initial inspection of factory and of factory production control	Inspection of the factory and the factory production control of the manufacturer as described in the MTD and the control plan	Control of devices and equipment and the documentation of the FPC	When starting the production process of the CE marked product or when starting a new production line
Continuous surveillance, assessment and approval of the factory production control	Surveillance, assessment and approval of the factory production control of the manufacturer as described in the MTD and the control plan	Control of the documentation of the FPC	At least twice per year, however if the results of the first inspection are satisfactory, a reduction to once a year can be considered.

D. 5.2.2.1 Assessment of the factory production control system - initial inspection and continuous surveillance

The Assessment of the factory production control system is the responsibility of the notified body.

The assessment shall be carried out of each production unit to demonstrate that the factory production control is in conformity with the ETA and any subsidiary information. This assessment shall be based on an initial inspection of the factory.

Subsequently continuous surveillance of factory production control is necessary to ensure continuing conformity with the ETA.

It is recommended that surveillance inspections be conducted once a year but if necessary i.e. if the results of the first inspection is unsatisfactory it may be required to be done more often e.g. twice per year.

D. 5.2.2.2 Certification of Factory Production Control

When the criteria of the assessment of the factory production control are fulfilled the notified body shall issue the Certification of the Factory Production Control.

D. 5.3 CE marking and accompanying information

According to Council Directive 93/68/EEC5 the CE marking consists of the letters "CE", followed by the identification number of the notified certification body,.

The ETA shall indicate the information to accompany the CE marking, i.e.

- The name and identifying mark of the producer and the manufacturing plant,
- The last two digits of the year in which the CE marking was affixed,
- the number of the EC certificate for the FPCThe number of the European technical approval,
- Name of the product.

Example of CE-Marking and accompanying information:

 Nnnn	<p>"CE"-symbol</p> <p>Number of Notified Body</p>
Any Company Street 1 Country Plant 1 Yy nnnn-CPD-xxxx	<p>Name and address of the ETA-holder or his representative established in the EEA and of the plant where the kit was manufactured</p> <p>Two last digits of year of affixing CE Marking</p> <p>Number of EC certificate for the FPC</p>
ETA-YY/WWWW ETAG XXX	<p>ETA Number</p> <p>ETAG Reference</p>

D. 5.4 Identification of the product

All components of the fasteners shall be marked with the manufacturers identification mark. This ensures that the fasteners correspond to the information given by the CE marking.

D. 6 The ETA content of fastener ETA

D.6.1 Definition of product and intended use

It shall be clearly stated in the ETA that the ETA only covers the performance characteristics of the fastener itself and that for the evaluation and use of the entire mechanically fastened roof waterproofing kit/system a separate ETA is necessary. Thus the wind uplift resistance of the entire system is enclosed in the system ETA.

The intended use of the fasteners according to D.3.1.2 shall be specified in the ETA.

Furthermore the corresponding substrate shall be specified.

D.6.2 Characteristics of product and method of verification

The following characteristics shall be given:

- Axial loading resistance according to D.2.1

5 (References)

- Unwinding resistance according to D.2.2 (if relevant)
- Mechanical resistance/brittleness of the plastic fastener according to D.2.3
- Aspects of durability according to D.3

The material properties shall be given in the ETA.

Furthermore a drawing of the fastener with the most important dimensions shall be given.

D.6.3 Evaluation of conformity of the product and CE marking

The criteria give in D.5 shall be taken into account.

D.6.4 Assumptions under which the fitness of the product for the intended use was favourably assessed

The criteria for manufacturing, design and installation shall be given.

D.6.5 Recommendations for the manufacturer

Recommendations for packaging, transport and storage shall be given.

It is recommended that plastic components are stored under normal climatic conditions in its original light-proof packaging. It is recommended that plastic components are kept in their original packaging until their immediately prior to use.