

European Organisation for Technical Approvals
Europäische Organisation für Technische Zulassungen
Organisation Européenne pour l'Agrément Technique

red. Anm. Diese nachstehende Bekanntmachung ist derzeit nur in der englischen Fassung verfügbar

ETAG 018

Edition January 2006
Amended May 2012

GUIDELINE FOR EUROPEAN TECHNICAL APPROVALS
OF

FIRE PROTECTIVE PRODUCTS

PART 3:

RENDERINGS AND RENDERING KITS
INTENDED FOR FIRE RESISTING APPLICATIONS

EOTA Kunstlaan 40, Avenue des Arts, B - 1040 Brussels

TABLE OF CONTENTS

FOREWORD	4
Section one: INTRODUCTION	6
1 PRELIMINARIES	6
1.1 Legal basis	6
1.2 Status of ETA-Guidelines	6
2 SCOPE	6
2.1 Scope	6
2.2 Use categories, product families, kits and systems	6
2.2.1 General	6
2.2.2 Use categories related to environmental conditions	7
2.2.3 Use categories related to the element to be protected	7
2.3 Assumptions	7
3 TERMINOLOGY	8
3.1 Common terminology and abbreviations	8
3.2 Particular terminology and abbreviations	8
Section two: GUIDANCE FOR THE ASSESSMENT OF THE FITNESS FOR USE	10
4 REQUIREMENTS	10
4.0 General	10
4.1 ER 1: Mechanical resistance and stability	10
4.2 ER 2: Safety in case of fire	10
4.3 ER 3: Hygiene, health and the environment	10
4.3.1 Content and/or release of dangerous substances	10
4.3.2 Water vapour permeability	10
4.4 ER 4: Safety in use	10
4.4.1 Mechanical resistance and stability	10
4.4.2 Resistance to impact / movement	10
4.4.3 Adhesion (bond strength)	10
4.5 ER 5: Protection against noise	10
4.6 ER 6: Energy economy and heat retention	10
4.7 Aspects of durability, serviceability and identification	11
4.7.1 Durability	11
4.7.2 Serviceability	11
4.7.3 Identification	11
5 SPECIFIC METHODS OF VERIFICATION	11
5.0 General	11
5.0.1 Use of methods of verification	11
5.0.2 Sampling and test specimens	12
5.0.3 Effects of drying	13
5.0.4 Conditioning of test specimens and test conditions	13
5.0.5 Assessment approach	13

5.1	Mechanical resistance and stability	17
5.2	Safety in case of fire	17
5.2.1	Reaction to fire	17
5.3	Hygiene, health and the environment	17
5.3.1	Content and/or release of dangerous substances	17
5.3.2	Water vapour permeability	18
5.4	Safety in use	18
5.5	Protection against noise	18
5.6	Energy economy and heat retention	18
5.6.1	Thermal insulation	19
5.6.2	Water vapour permeability	20
5.7	Related aspects of durability, serviceability and identification	19
5.7.1	Durability	19
5.7.2	Serviceability	20
5.7.3	Identification	24
6	ASSESSING AND JUDGING THE FITNESS OF PRODUCTS OR KITS FOR INTENDED USE	26
6.0	General	26
6.1	Mechanical resistance and stability	26
6.2	Safety in case of fire	26
6.2.1	Reaction to fire	26
6.2.2	Fire resistance	26
6.3	Hygiene, health and the environment	26
6.3.1	Content and/or release of dangerous substances	26
6.4	Safety in use	26
6.5	Protection against noise	26
6.6	Energy economy and heat retention	27
6.6.1	Thermal insulation	27
6.6.2	Water vapour permeability	27
6.7	Related aspects of durability, serviceability and identification	27
6.7.2	Serviceability requirements	28
6.7.3	Identification	29
7	ASSUMPTIONS AND RECOMMENDATIONS UNDER WHICH THE FITNESS FOR USE OF THE PRODUCTS IS ASSESSED	29
7.0	General	29
7.1	Design of works	29
7.2	Packaging, transport and storage	30
7.3	Execution of works	30
7.3.1	Site tests	31
7.4	Maintenance and repair	31
7.5	Auxiliary components	31

Section three: ATTESTATION OF CONFORMITY	32
8 ATTESTATION OF CONFORMITY	32
8.1 EC-decision	32
8.2 Responsibilities	32
8.2.1 Tasks for the ETA holder	32
8.2.2 Tasks for the Notified Product Certification Body	33
8.3 Documentation	33
8.4 CE-marking and information	34
Section four: ETA CONTENT	35
9 THE ETA CONTENT	35
9.1 The ETA-content	35
9.1.1 Identification of materials	35
9.1.2 Performance	35
9.1.3 Drawings	35
9.1.4 Installation	35
9.1.5 Maintenance and repair	37
9.2 Additional information	37
ANNEX A List of reference documents	38
ANNEX B Reaction to fire tests for building products – Mounting and Fixing Arrangements	41
B.1 Testing according to EN 13823 (SBI)	41
B.2 Testing according to EN ISO 11925-2 (small burner test)	41
B.3 Testing according to EN ISO 1716 and EN ISO 1182	41
ANNEX C Test method for evaluating corrosion of steel substrates induced by the rendering	45
ANNEX D Test Method for Air Erosion of Renderings	45
ANNEX E Durability Testing of Renderings	47
E.1 Introduction	47
E.2 Specimens	47
E.3 UV exposure	47
E.4 Heat – rain	47
E.5 High humidity	47
E.6 Heat – cold	47
E.7 Freeze-thaw	48
E.8 Adhesion – Test procedure	48
E.9 Insulation efficiency – Test procedure	49
E.10 Visual observations	50
ANNEX F Determination of the declared thermal conductivity and the conversion factor to high moisture content (for mineral wool based renderings)	51

FOREWORD

Background

This ETA-Guideline has been established by the EOTA WG 11.01/04 Fire Protective Products.

This ETA-Guideline - Part 3 "Renderings and rendering kits intended for fire resisting applications" shall be used in conjunction with the ETA-Guideline "Fire protective products" Part 1 "General". This complementary part expands and/or modifies the requirements given in Part 1 "General", taking into account the specific family of products referred to.

This ETA-Guideline can be used to issue an ETA for fire protective renderings and fire protective rendering kits.

There are three options:

- Option 1: The ETA only covers the fire protective rendering product (dry mix) evaluated in its end use application directly applied to the substrate without the use of additional components such as a bonding agent, reinforcing mesh, fixings, top coat/sealing coat or additives.
- Option 2: The ETA covers an actual kit comprising the rendering product (dry mix) plus one or more specified additional components such as a bonding agent, reinforcing mesh, fixings, top coat/sealing coat or additives; evaluated in the end use application as a rendering and being supplied by the producer as a rendering kit. All components need to be identified, and subjected to the assessment and all factory production control (FPC) requirements. The rendering kit shall comprise at least two components.

NOTE 1: Any additional components not supplied as part of an actual kit are considered to be a part of the final assembly under Option 3.

- Option 3: The ETA is issued for a "final assembly". The ETA only covers the rendering product (dry mix), but one or more identified additional components such as primer(s), bonding agent, reinforcing mesh, fixings, top coat/sealing coat or additives need adding on site to form the system. These are evaluated in the end use application as a rendering but with all additional components being placed on the market by other than the producer of the rendering product. The identification of the additional components may be specific (e.g. by trade name or type) or generic (e.g. family of primers or by minimum properties and/or performance). All components of the "final assembly" are subjected to the assessment, but only the rendering product (dry mix) is subjected to the FPC requirements.

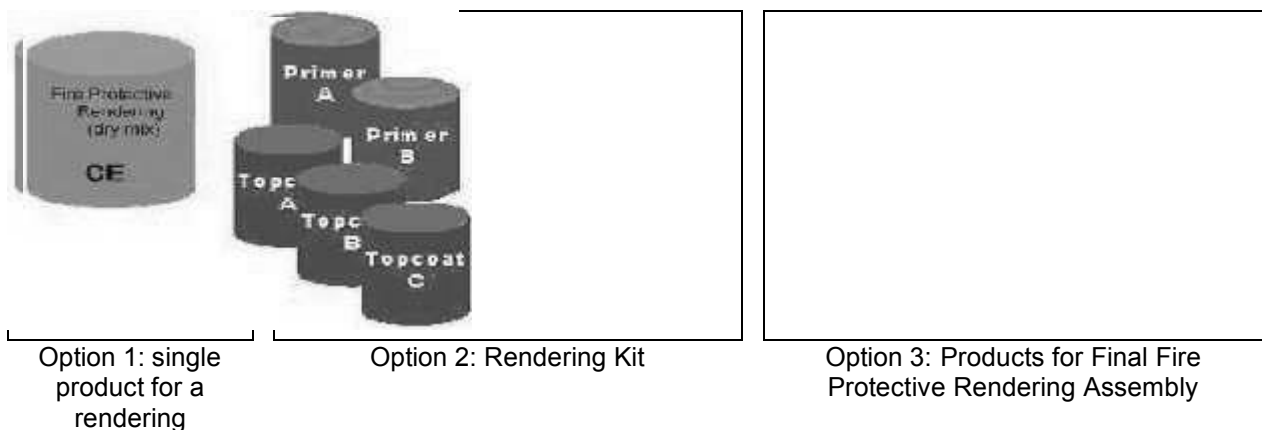

NOTE 2: The CE marking in the drawings indicates which component(s) will be covered by the ETA. In option 2, only the kit is CE marked, the individual components do not need to be.

List of reference documents

This ETA-Guideline Part 3 incorporates, by dated or undated reference, provisions from other publications. These normative references are cited at the appropriate places in the text and the publications are listed in Annex A. For dated references subsequent amendments to, or revisions of these publications, apply to this ETA-Guideline only when incorporated in it by amendment or revision. For undated references the latest dated revision of the publication referred applies.

Section one: INTRODUCTION

1 PRELIMINARIES

1.1 Legal basis

The legal basis of this ETA-Guideline is given in Part 1 “General”, 1.1.

1.2 Status of ETA-Guidelines

The status of ETA-Guidelines is given in Part 1 “General”, 1.2.

2 SCOPE

2.1 Scope

This Part 3 shall be used in conjunction with Part 1 “General”.

This ETA-Guideline Part 3 “Renderings and rendering kits intended for fire resisting applications” specifies the terminology and definitions, the specific methods of verification and for identification, the classification criteria for renderings and rendering kits intended for fire resisting applications and requirements for the identification of their component characteristics.

It also gives guidance for the assessment of the specific installation instructions and for the Attestation of Conformity. It is applicable to renderings and rendering kits intended for fire protective purposes applied to the following substrate materials:

- Steel¹,
- Concrete,
- Timber² (including wood based board products),
- Masonry,
- Boards (including, for example plasterboard and calcium silicate types).

NOTE 3: The Guideline does not deal with prefabricated shells or elements for curtain walls.

2.2 Use categories, product families, kits and systems

2.2.1 General

For the purpose of this ETA-Guideline, the Fire Protective Products have been divided into:

- Part 2 - “Reactive coatings for fire protection of steel elements”,
- Part 3 - “Renderings and rendering kits intended for fire resisting applications”,
- Part 4 - “Fire Protective Boards, Slab and Mat Products and Kits”.

In this Part, additional specifications are given for renderings and rendering kits. The component specifications are specified in:

- this ETA-Guideline, or
- European technical specifications as referred to in the Construction Products Directive, i.e.:

¹ Other metals are not excluded but additional verification methods may be required.

² The effect of any preservation treatment of timber and timber products is not considered. A case by case approach is necessary in order to demonstrate adhesion (bond strength) and compatibility for renderings without additional mechanical support.

- harmonised European product standards as published by CEN (see Annex A), or
- European Technical Approvals as published by EOTA.

2.2.2 Use categories related to environmental conditions

The use categories related to the type of environmental conditions are based on the general principles specified in Part 1 “General”, clause 2.2.1. The use categories are the following:

- Type X: Renderings and kits intended for all conditions (internal, semi-exposed and exposed),
- Type Y: Renderings and kits intended for internal and semi-exposed conditions. Semi-exposed includes temperatures below 0 °C, but no exposure to rain and limited exposure to UV (but the effect of UV exposure is not assessed),
- Type Z₁: Renderings and kits intended for internal conditions with humidity equal to or higher than 85 % RH, excluding temperatures below 0 °C³,
- Type Z₂: Renderings and kits intended for internal conditions excluding temperatures below 0 °C, with humidity lower than 85 % RH.

NOTE 4: Products that meet the requirements for type X, meet the requirements for all other types. Products that meet the requirements for type Y also meet the requirements for types Z₁ and Z₂. Products that meet the requirements for type Z₁ also meet the requirements for type Z₂.

NOTE 5: Requirements relevant for the establishment of the use categories are presented in the clauses 6.7.1.2 to 6.7.1.6.

It is acceptable for a rendering to be intended for internal applications only, however, the construction process may result in a rendering being subjected to outdoor conditions for an extended period before the building envelope is closed. In this case the conditions during the construction process could be more severe than intended for the final end use. The following possibilities shall be taken into consideration to avoid disadvantages:

1. Special provisions shall be made to protect temporarily the exposed rendering according to the instructions of the producer included or referenced in the ETA, or
2. the rendering shall be evaluated as if it were intended to be used for exposed applications (Type X), or
3. for established products only, evaluation of the rendering for use category type Y or type Z applications (as appropriate) and acceptance by the Approval Body of the possibility of short term exposure based on long term experience and evidence of such exposure.

This ETAG does not give specific test or assessment methods for resistance to specific environmental conditions, but this may be assessed on a case by case basis as necessary. The Approval Body shall obtain suitable evidence for the assessment and present details in the ETA.

For exposed and semi-exposed applications renderings may require the use of sealing coats / top coats to assist in the resistance to weathering.

The resistance of the product to specific environmental conditions shall be assessed on a case by case basis. The Approval Body shall obtain suitable evidence for the assessment and present details in the ETA.

2.2.3 Use categories related to the element to be protected

The use categories are identified in Part 1 “General” as Types 1 – 10. This Guideline covers the application of renderings to Types 1 to 10. Type 8 includes protection of plasterboard by plaster based rendering.

2.3 Assumptions

The assumptions made are given in Part 1 “General”, 2.3.

The provisions, test and assessment methods in this Guideline, or referred to, have been written based on an assumed working life of the product for the intended use of 25 years. The provisions are based upon the current state of the art and the available knowledge and experience.

³ These conditions apply for internal humidity class 5 in accordance with EN ISO 13788.

If a satisfactory performance of the product is not established in the durability tests then an estimated working life of 10 years may be attributed based on a favourable assessment of serviceability/identification tests (e.g. flexural and compressive strength and where possible adhesion/bond strength) but only for use category Z₂. Additional evidence of the product in actual service may also be taken into account.

3 TERMINOLOGY

3.1 Common terminology and abbreviations

The common terminology and abbreviations are given in Part 1 “General”, clause 3.1.

Unless the text is more specific, in this ETAG the term "product" means "product and/or kit"

3.2 Particular terminology and abbreviations

For the purpose of this ETA-Guideline Part 3, the particular terminology and abbreviations as given in Part 1 “General”, 3.2 apply. The following specific terminology and abbreviations shall also apply:

Rendering (spray or trowel applied fire protective material):

The applied product for fire protection comprises only:

- 1 Spray-applied gypsum or cement binder mixed with one or more aggregates and/or fibres. The product is mixed with water to produce a slurry and sprayed wet;
- 2 Spray-applied mineral wool mixed with a binder, filler or aggregates. The product is sprayed dry and mixed with water at the nozzle. The binder may be included as part of the dry mix in the bag or may be added with the water at the nozzle;
- 3 Trowel applied gypsum or cement binder mixed with one or more aggregates and/or fibres mixed as a slurry at a consistency which enables it to be trowel-applied to conform with the profile of the substrate;
- 4 The same materials as in 1, 2 and 3 above but trowel applied and mixed at a consistency which allows the “patch repair” of “small areas” of materials described in sections 1, 2 and 3 above.

The term ‘rendering’ used in this ETA-Guideline refers to the applied, dried and hardened material.

Mechanical fixings:

Mechanical fixings are components to key or to reinforce the rendering to the substrate.

- Keying mesh: mesh of metal or other material of relatively small aperture size, typically 10 mm to 25 mm which allows some penetration of spray to produce a good key and applied in close proximity or fixed to the substrate. Typical types: expanded metal lath, ribbed expanded lath, welded mesh, woven hexagonal mesh.
- Reinforcing mesh: mesh of metal or other material of relatively large aperture size, typically 25 mm which allows full penetration of the rendering and hence provides reinforcement. Typical types: welded mesh, woven hexagonal mesh. A reinforcing mesh is typically positioned in the middle third of the rendering thickness.

ETA applicants shall reference standard types of lath defined in EN 13658-2.

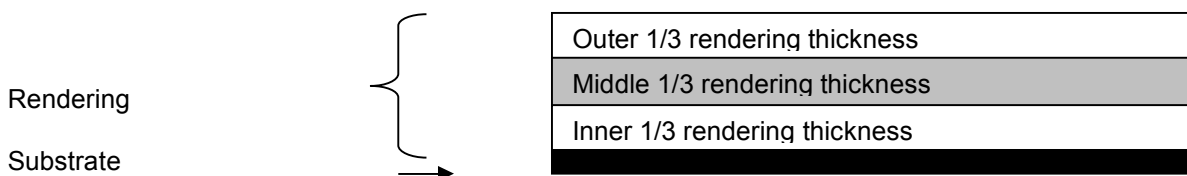

- Discontinuous metal fixings: pins welded, shot-fired or screwed to the substrate and bent, split or fixed with large diameter washers or spring clips to key the rendering or used to support keying or reinforcing mesh.

The mechanical properties of the fixings shall be in line with ISO 898-1, or if stainless-steel fasteners (bolts or screws) are used, with EN 3506-1.

Primer:

Primers are components used for:

- corrosion protection, a coating applied directly to a suitably prepared steel surface to provide corrosion protection, or
- bonding agent, a liquid component not part of the dry mix and not mentioned in its formulation, applied to the substrate separately or mixed with the rendering and applied as a thin first layer to ensure or to improve the adhesion (bond strength) of the rendering on the substrate, especially if no mechanical fixing is used.

Additives:

Additives are components not part of the dry mix and not mentioned in its formulation; added to the water or to the fresh mixed slurry before spraying to ensure or to improve the adhesion (bond strength) of the rendering, to accelerate or retard the setting process or to influence the porosity.

Rendering kit ('kit'):

The rendering kit comprises the dry mix (usually delivered in bags) and one or more other components such as bonding agent, reinforcing mesh, fixings, top coat / sealing coat or additives provided by the ETA holder.

Top coats / Sealing coats:

These materials are generally components of an "external grade" rendering kit where the rendering requires additional weathering resistance. They may also be used to protect the rendering from mechanical damage, or be provided purely for decorative purposes without any claimed contribution to performance.

These materials can be:

- coatings of low viscosity intended to soak into the surface of the rendering,
- coatings of high viscosity which are either spray or brush applied as a surface sealing coat over the rendering.

Product:

The product is the dry mix as supplied by the ETA applicant excluding fixings, reinforcement or other components incorporated into the dry or wet mix on site. Recycled material as a constituent of the dry mix is acceptable under this ETA-Guideline, as long as the recycled constituent is part of the assessment performed in accordance with this ETA-Guideline.

Shelf life:

The shelf life describes the maximum time for which the dry mix shall be stored under the specified storage conditions.

Pot life:

This term describes the maximum time within which the dry mix, once mixed with water and any other additives, shall be used and finally applied.

Batch:

Batch means the unit or quantity of production in a single complete production operation. The volume which constitutes a batch in converting the raw material into the finished product is called "batch size" .

Section two: GUIDANCE FOR THE ASSESSMENT OF THE FITNESS FOR USE

4 REQUIREMENTS

4.0 General

The performance requirements, establishing the fitness for use of fire protective renderings and kits, shall be in accordance with Part 1 "General" - Chapter 4, and with the following specific stipulations for this family of products.

The provisions, test and assessment methods in this Guideline, or referred to, have been written based upon the assumed intended working life of the product for the intended use of 10 or 25 years, provided that the product is subject to appropriate use and maintenance in accordance with Chapter 7. These provisions are based upon the current state of art and the available knowledge and experience.

4.1 ER 1: Mechanical resistance and stability

See Part 1 "General", Table 4.1.

4.2 ER 2: Safety in case of fire

See Part 1 "General", Table 4.1.

4.3 ER 3: Hygiene, health and the environment

See Part 1 "General", Table 4.1.

The provisions of EOTA Technical Report 034 (version July 2009) shall be taken into account.

4.3.1 Content and/or release of dangerous substances

The product shall be such that, when installed according to the appropriate provisions of the Member States, it allows for the satisfaction of the Essential Requirement 3 of the CPD as expressed by the national provisions of the Member States. Where applicable, the product shall also satisfy ER 3 in respect of the product being allowed to be placed on the market (for example meeting content restrictions)

4.3.2 Water vapour permeability

See clause 5.6.2

4.4 ER 4: Safety in use

4.4.1 Mechanical resistance and stability

See Part 1 "General".

4.4.2 Resistance to impact / movement

See Part 1 "General".

If this property of a vertical element is relevant, ISO 7892 shall be applied.

4.4.3 Adhesion (bond strength)

See Part 1 "General".

The fire protective rendering shall adhere to the substrates, such that the system will have the required fire protective performance.

NOTE 6: This requirement relates to other requirements as well, in particular to ER 2 and to aspects of serviceability.

4.5 ER 5: Protection against noise

See Part 1 "General", Table 4.1.

4.6 ER 6: Energy economy and heat retention

See Part 1 "General", Table 4.1.

4.7 Aspects of durability, serviceability and identification

4.7.1 Durability

Deterioration may be caused by physical, biological or chemical agents. But the materials and components of fire protective renderings shall not deteriorate during their assumed intended working life so as to affect significantly the performance of the products in relation to fulfilling all the Essential Requirements 2 to 6, especially the protective effects in case of fire. Where physical damage is able to be repaired, the specification, method and scope of damage repair together with any limitations shall be specified.

4.7.1.1 Behaviour under different environmental conditions

The fire behaviour of the fire protective rendering shall not change significantly during the working life, if the rendering is used in the defined use conditions. The ETA-Applicant shall claim durability of the rendering according to the use categories in clause 2.2.2.

4.7.1.2 Corrosion resistance

The rendering shall not react adversely with the intended substrate(s) and where required a primer shall provide corrosion protection to the substrate.

4.7.1.3 Resistance to chemicals

The fire protective rendering may or may not be influenced by chemicals. For specific areas of application, where rendering may be exposed to chemicals, additional verifications may be required.

The extent of testing of resistance to chemicals depends on the ETA-Applicant's claims.

4.7.1.4 Resistance against biological attack

Rendering products may be influenced by biological effects, i.e. mould growth and/or subject to deterioration due to attack by insects or mammals, e.g. rodents.

This ETA-Guideline foresees no assessment to cover this eventuality. In general, it is an assumption that design provisions will prevent deterioration from occurring (see Chapter 7). Where Approval Bodies expect biological attack to be of particular importance for specific products, additional, case-by-case assessment shall take place, taking into account the nature of the biological agent.

4.7.2 Serviceability

See Part 1 "General", clause 4.7.

4.7.3 Identification

See Part 1 "General".

The materials and components of the fire protective rendering shall be identifiable as to their properties which have an influence on the ability of the rendering to fulfil the Essential Requirements.

The determination of characteristics and properties of the product for identification purposes shall be as specified in the tests listed in clause 5.7.3.

5 SPECIFIC METHODS OF VERIFICATION

5.0 General

This chapter refers to the verification methods used to determine the various aspects of performance of the product in relation to the requirements for the works (calculation, tests, engineering knowledge, site experience, etc.). The methods of verification given in Part 1 "General" - Chapter 5 apply, except where modified or specified below (see Table 5.1).

5.0.1 Use of methods of verification

The performance characteristics for rendering kit components shall be verified in accordance with European technical specifications for the kit or component under consideration of:

- harmonised European product standards as published by CEN (see Annex A), or
- European Technical Approvals as published by EOTA,

unless this ETA-Guideline considers product characteristics (including identification, serviceability and

durability) that are not covered by those European technical specifications.

Kit components shall only be subjected to the verification methods specified below if the corresponding characteristics are relevant for the kit component under consideration and as far as relevant for its fitness for intended use(s). Characteristics for which the NPD-option is not allowed (see Part 1 "General", Table 6.1) shall always be verified.

5.0.2 Sampling and test specimens

Where possible, samples of the product for all approval tests shall be taken at the manufacturing site (production, storage) and shall be representative of the rendering for which approval is being sought.

All samples for test specimens for each product shall be taken at the same time, and from the same batch, in accordance with EC Guidance Paper K, ensuring that approval test results can be validated for initial type testing under attestation of conformity (see Chapter 8). If sampling at the same time is impossible for practical reasons, measures shall be taken to ensure that all samples taken have identical constituents and composition. In the latter case the Approval Body needs to provide relevant evidence of measures taken to those responsible for attestation of conformity (see Chapter 8).

The specimens for approval tests shall as far as possible be prepared at the same time and in accordance with the ETA-Applicant's application method in order to minimize differences caused by variations in specimen preparation. Simultaneously, samples for density determination shall be prepared (see below). This is in order to relate the characteristics of the material to the fire performance achieved.

Alternatively density may be determined by measurement of actual test specimens.

Density

In most cases, ETA-applicants shall specify both spray (large surfaces) and trowel (small surfaces) applied rendering. Therefore, unless the ETA-Applicant specifies the method of application, or the more onerous application method can be determined, tests shall be conducted with both spray and trowel applied material and the density of both shall be measured. The ETA shall specify the densities and their tolerances for trowel and spray applied⁴ renderings.

The density shall be determined by appropriate methods relating to the type of rendering under evaluation. For the assessment of the density the method given in EN 13381 (apply the Part which relates to the type of use to be tested) shall be used, where possible.

The density of all test specimens is required to be within $\pm 15\%$ of the mean value of the fire test specimens. If measured densities are outside of the prescribed tolerance, additional tests shall be conducted to evaluate a wider density range to be quoted in the ETA.

The quoted density of the applied rendering with its tolerance is deemed to be the value at which the performances declared in the ETA including fire resistance are valid.

In addition, a declared value of density with its tolerance may be specified in the ETA according to other methods⁵.

The method agreed to be used to declare density shall also be used for identification and FPC purposes. The declared values of density may also serve as benchmarks for site tests as referred to in clause 7.3.1.

Thickness

The thickness of the hardened rendering of all test specimens shall be measured using a 1 mm diameter probe or drill, which shall be inserted into the material at each measurement position until the tip of the probe or drill touches the surface of the test specimen substrate. The probe or drill shall carry a circular steel plate of approximate diameter 50 mm but at least 30 mm upon it, for accurate determination of the surface level.

For fire resistance tests, the thickness of the test specimen shall be measured in the proximity, between 50 mm and 100 mm away from each of the thermocouples fixed to the substrate, beneath the applied fire protection system.

⁴ The application method shall be specified in the ETA.

⁵ If appropriate, EN 1015-6, EN 1015-10 or other methods can be used to determine the declared density. In this case the mean value shall be determined on the basis of at least 10 measurements.

For all other test specimens, the measurements shall be geometrically uniformly distributed over the surface of the test specimen, but shall include measurement of any visibly smaller thicknesses. The minimum number of measurements per test specimen is 10.

The thickness of the test specimen shall not deviate by more than 20 % of the mean value over the whole of its surface. In this case, the mean value shall be used in the assessment of the results and the limits of applicability of the assessment. If it deviates by more than 20 %, the maximum thickness recorded shall be used in the assessment.

The surface of the substrate for the specimens shall reflect the surface conditions claimed by the ETA-Applicant, as specified in the application instructions for the product.

Unless specified differently for a particular test the following standard substrates shall be used for the tests :

a) Steel as specified according to EN 10025 grade S, except S185, of nominal size 500 mm x 500 mm and of thickness not less than 5 mm.

Where galvanized steel is used as substrate, EN ISO 1460 or EN ISO 1461 applies.

b) Concrete as specified in EN 1323 of minimum size 300 mm x 400 mm and of nominal thickness 40 mm.

c) Wood based panels (also covering solid timber) and particle boards as specified in EN 312:2010, of density $700 \text{ kg/m}^3 \pm 10 \%$, nominal size 500 mm x 500 mm and (20 ± 2) mm thick.

d) For boards other than those in c), the specific board type shall be used.

5.0.3 Effects of drying

The applied rendering is required to harden and cure with minimal shrinkage or cracking and to maintain dimensional stability and not crack during its working life. The samples prepared for the tests referenced in clauses 5.7.2.2.1, 5.7.2.2.2 or 5.7.2.2.3 and those for fire testing can be used to evaluate the effects of drying of the rendering.

Hairline cracks that develop as a result of drying may be accepted providing the desired results are achieved in the fire tests with the presence of cracking. Observations shall be made on the effect of drying and hardening with respect to shrinkage and cracking.

Cracks up to the size and density of those exhibited by the fire test specimens prior to test are acceptable. This shall be expressed in the ETA as maximum width of crack and total length of cracks per square metre of rendering.

5.0.4 Conditioning of test specimens and test conditions

The rendering test specimens shall be applied and fully cured according to the ETA-Applicant's instructions.

Except where conditioning is specified in a referenced test method, the prepared test specimens shall be conditioned at $(23 \pm 2) ^\circ\text{C}$ and $(50 \pm 5) \%$ relative humidity for at least 28 days or until constant mass, i.e. until two subsequent mass measurements differ less than 1 % over a 24 h period.

The laboratory conditions shall be $(20 \pm 10) ^\circ\text{C}$ and $(50 \pm 20) \%$ relative humidity.

5.0.5 Assessment approach

5.0.5.1 General

Approval Bodies will in many cases be confronted with a kit or "assembled system" (see the FOREWORD), consisting of the dry mix render and one or more primers and one or more top coats or an assessment that includes those other products. Primers, topcoats, reinforcements and mechanical fixings and additives may be referred to specifically (by trade name and type) or generically, by generic product or generic family in the case of primers. The kit-components are always referred to specifically. All others components, specific or generic, shall be specified in the ETA according to the available technical specifications (e.g. EN or ETA) or, when this is not possible, by reference to proprietary items, physical dimensions and material performance. In the case of primers, when they are not specific, reference to the generic families indicated in clause 5.0.5.2 shall be made.

Some rendering systems, with or without top coat, can be applied directly on the substrate. In the case of steel substrates, this is either due to the steel substrate not requiring additional protection, taking into account the intended use (e.g. weathering steels complying with EN 10025-2 or stainless steels complying with EN 10088 Part 2:2005 or Part 3:2005) or because the steel substrate has been protected by metallic coatings, using hot-dip galvanizing (EN 10326 or EN 10327) or thermal zinc or aluminium spraying. If the

rendering can be applied without primer, tests shall be performed accordingly.

It is recognized that in the majority of cases the steel elements will arrive on site already primed. In that case, it is necessary for the rendering applicator to ensure that the primer is compatible with the rendering. For this case provisions are given in Chapter 7.

If renderings can be applied with and without primer(s), both situations shall be assessed.

5.0.5.2 Primer evaluation

5.0.5.2.1 Bonding agents provided for the purpose of providing a 'key' for the rendering

If the rendering system is intended to be used with one or more specifically referenced bonding agents, all system tests, i.e. all tests not performed on the individual components, foreseen in this chapter shall be carried out using the specifically referenced bonding agent(s). The specifically referenced bonding agent(s) shall be identified in the ETA and be subjected to FPC as specified in this Guideline, if they are kit components.

5.0.5.2.2 Corrosion protection primers, specific or generic

There are two options for assessing primers and covering primers in the ETA: generic types or specific primers.

The most commonly used generic types of primer and their nominal thickness range are given in Table 5.0. Only one primer from a primer family is subjected to testing and primer types not covered by the generic types listed in Table 5.0 shall be the subject of a separate evaluation in accordance with Annex E.9. If a primer is tested on uncoated steel but is intended to be used on galvanised steel as well, a separate evaluation on galvanised steel shall be made. In this case the maximum thickness shall not be more than 50% of the tested thickness.

Each generic primer group shall be evaluated separately; where the ETA-Applicant specifies that water borne and solvent borne materials may be used, both shall be tested. Solvent free materials shall be classed in the same generic group as the solvent borne equivalent.

Table 5.0: Generic primer types

Generic primer type	Maximum approved thickness - permitted extension from the tested thickness (%) ⁶
Acrylic	+ 50
Short/medium oil alkyd	+ 50
Two component epoxy	+ 50
Zinc rich epoxy (containing about 80% by mass of metallic zinc powder)	+ 50
Zinc silicate	+ 50

In all cases the dry thickness of the primer shall not exceed the maximum dry thickness for each product as recommended by the ETA-Applicant.

Where the primer contains zinc metal there may be a requirement to include a further tie coat or pre-treatment, in which case this shall be included in the system to be tested.

When a primer from any generic group is tested, the generic approval will be limited to other primers in the group provided the maximum thickness is lower than the permitted extension given in Table 5.0. Any thicknesses below that tested shall be acceptable provided the lower thickness is not less than that recommended by the ETA-Applicant.

If no primer is used, the surface preparation shall be specified and tested in accordance with Annex E.9.

Compatibility testing carried out on steel panels will be acceptable for other ferrous substrates except stainless steel, which shall be evaluated separately in accordance with Annex E.9.

⁶ No (-) tolerance is permitted.

Primers not covered by the families identified above may be grouped in other families of primers based on the binder (e.g. oil alkyd or epoxy), carrier (organic, solvent/water) and pigment (e.g. inhibitive or non-inhibitive) type.

Durability testing with a primer from the generic type of zinc rich epoxy primer does not cover galvanized steel, for instance hot dip galvanized steel. Galvanized steel is treated as another form of “primer” and has to be tested separately.

All tests/assessments according to the clauses 5.2 to 5.7 shall be carried out with a primer chosen by the applicant. However, where the rendering is intended to be used with more than one primer family an insulation efficiency test (as specified in Annex E.9) is necessary for the additional primers. When fire tests are carried out without a primer, the efficiency test can be also used to assess the use of primers. Only one primer from a primer family shall be subjected to testing.

The tests are valid for primers with the same carrier (water borne or solvent borne) and for related similar thicknesses (a range of validity for tested dry film thickness shall be given).

It is assumed that the result “pass” within the insulation efficiency test is a basis for the assessment of a comparable behaviour in all other tests (e.g. fire resistance tests, durability test).

For the pass/fail criteria see clauses 6.7.1.2 to 6.7.1.8.

It is recognized that in the majority of cases the steel elements will arrive on site already primed. In such instances, it is necessary for the rendering applicator to ensure that the primer is compatible with the rendering. For this case provisions are given in Chapter 7.

However, where the primer is found to be a type not covered by the ETA, the ETA does not cover the use of the rendering intended to be applied and an additional assessment shall be done.

5.0.5.2.3 Existing data

For existing products, in some circumstances, it might be possible to assess the performance in fire of systems with alternative primers using existing data from tests other than to the specified EN standard (for example to equivalent national test standards).

If the alternative data is from a fire resistance test which is substantially similar to the specified EN test, this data may be used in conjunction with the EN test data, corresponding to one specific primer, to support an assessment for an alternative primer. In particular, if the alternative test is substantially similar to the specified EN test in terms of thermal exposure, mechanical stress, scale of deformation and deflection etc., the “stickability” and overall performance of the rendering system might be assessed.

It is likely that existing test data may be from fire resistance tests where the furnace heating regime was not exactly the same as that in the specified EN test. For example, the plate thermometer may not have been used for measuring furnace temperatures. Nevertheless, the existing data may still be used if it provides a comparison of performance between the alternative primers in the same heating regime and was conducted at an accredited, independent laboratory.

5.0.5.3 Top coat evaluation

All tests according to clause 5.7.2 shall be conducted without a top coat unless the top coat is necessary to provide the required performance under the particular exposure conditions. In this case the rendering shall be tested with the specified top coat.

The Approval Body shall decide which characteristics are dependent on the top coat for their performance, (e.g. adhesion may be independent of the top coat).

If the rendering is claimed to be equally suitable with and without top coat for environmental conditions types Z₁ and Z₂, the initial tests shall be performed with panels with and without top coat to show that the top coat has no influence on the insulation efficiency. For determining the insulation efficiency after exposure, it is sufficient to perform the tests without top coat. The top coat shall be specified in the ETA. The colour of the top coat has no influence on the result of the durability assessment for types Z₁ and Z₂. Therefore there is no need to test different colours of the top coat. The use category in the ETA is valid for all top coat colours.

For environmental use categories type Y and type X the test results could be influenced by the various top coat types and their colours. No generic approach is possible in relation to the type of top coat, so the applicant has to test all top coats. However, in order to cover all colours of a particular top coat, a colour

having an index $L < 50$ on the CIELAB⁷ scale (see ISO 7724:1984) shall be selected for test. The decision to choose the colour of the top coat used in durability assessment is taken by the Approval Body and the ETA-Applicant. The test results are valid for the tested top coat and all its different colours.

5.0.5.4 Reinforcements and mechanical fixings

All tests according to clause 5.7.2 shall be conducted without reinforcement or mechanical fixings unless the reinforcement or mechanical fixings are necessary to provide the required performance under the particular exposure conditions. In this case the rendering shall be tested with the specified reinforcement or mechanical fixings which shall be specified in the ETA.

NOTE 7: Determining the reinforcement(s) and/or mechanical fixing(s) that lead(s) to worst performances within each family of primers is a decision taken by the Approval Body and the ETA-Applicant, on a case-by-case basis, until European consensus can be achieved.

Table 5.1: Relationship between the ETAG paragraph on product performance and the ETAG paragraph on the verification method

ER	ETAG paragraph on product performance		ETAG paragraph on verification method of product characteristics	
			Rendering (renderings & fixings)	
1	4.1	Mechanical resistance and stability	Not relevant for these products	
2	4.2	Safety in case of fire	5.2.1	Reaction to fire
			5.2.2	Fire resistance
3	4.3	Hygiene health and environment	5.3.1	Release of dangerous substances
			5.3.2	Water vapour permeability
4	4.4	Safety in use	5.7.2	Serviceability
	4.4.1	Mechanical resistance and stability	5.7.2.1	Mechanical resistance and stability
	4.4.2	Resistance to impact/movement	5.7.2.2	Resistance to impact/movement
	4.4.3	Adhesion (bond strength)	5.7.2.6	Adhesion (bond strength)
5	4.5	Protection against noise	5.5	See Part 1 "General"
6	4.6	Energy economy and heat retention	5.6	See Part 1 "General"
			5.6.1	Thermal insulation
			5.6.1.1	Method for mineral wool based renderings
			5.6.1.2	Method for renderings other than mineral wool based ones
	4.7	Durability, serviceability and identification	5.7.1	Durability
	4.7.1	Durability	5.7.1.1	General
			5.7.1.2	Resistance to UV exposure
			5.7.1.3	Resistance to deterioration caused by heat and rain
			5.7.1.4	Resistance to deterioration caused by high humidity
			5.7.1.5	Resistance to deterioration caused by heat and cold
			5.7.1.6	Resistance to deterioration caused by freezing and thawing
			5.7.1.7	Resistance to corrosion of a steel substrate induced by the rendering
			5.7.1.8	Resistance to corrosion of the fixings induced by the rendering

⁷ "Commission International de l'Eclairage" (CIE) system of colour space defines lightness/darkness (L) scale in CIELAB units. White is defined as $L = 100$ and black as $L = 0$.

	4.7.2 Serviceability	5.7.2 Serviceability, See Part 1 "General" 5.7.2.1 Mechanical resistance and stability 5.7.2.2 Resistance to impact/movement 5.7.2.3 Air erosion 5.7.2.4 Water vapour permeability 5.7.2.5 Water absorption 5.7.2.6 Adhesion (bond strength)
	4.7.3 Identification	5.7.3 Identification

5.1 Mechanical resistance and stability

This Essential Requirement is not relevant for these products, see Part 1 "General", clause 5.1.

5.2 Safety in case of fire

5.2.1 Reaction to fire

See Part 1 "General", clause 5.2.1.

The rendering shall be classified in accordance with EN 13501-1⁸. If the rendering is intended to be used with and without a top coat, both situations shall be tested.

Guidance on mounting and fixing arrangements for the relevant tests is given in Annex B of this document.

5.2.2 Fire resistance

See Part 1 "General", clause 5.2.2.

In order for an ETA to be issued for the rendering or rendering kit it shall be the subject of at least one fire resistance test and shall be classified in accordance with EN 13501-2 and/or EN 13501-3 as appropriate.

Separate testing and classification shall be conducted for each type of substrate.

There also exists the possibility of applying calculation methods based on the Euro-codes, see Part 1 "General", clause 9.2.

5.3 Hygiene, health and the environment

5.3.1 Content and/or release of dangerous substances

5.3.1.1 General

The applicant shall

- submit the chemical constitution and composition of the product and/or constituents of the product to the Approval Body which will observe strict rules of confidentiality; or
- submit a written declaration to the Approval Body stating whether or not and in which concentration the product and/or constituents of the product contains substances which have to be classified as dangerous according to Directive 67/548/EEC and Regulation (EC) No 1272/2008 and listed in the "Indicative list on dangerous substances" of the EGDS - taking into account the installation conditions of the construction product and the release scenarios resulting from there.

The use of recycled materials shall always be indicated, because this could lead to the implementation of further assessment and verification methods.

The information concerning the presence of dangerous substances listed in Council Directive 67/548/EEC and Regulation (EC) No 1272/2008 regulated at European level and listed in the "Indicative list on dangerous substances" of the EGDS and/or of other dangerous substances, shall be circulated as part of the evaluation report by the issuing Approval Body to the other Approval Bodies, under strict conditions of confidentiality.

⁸ In this text "classification according to EN 13501 -1" means classification according to EN 13501 -1, or classification A1 according to Decision 96/603/EEC as amended or according to a relevant CWFT decision as stated in the FOREWORD of EN 13501-1.

5.3.1.2 Method of verification

The product and/or constituents of the product listed in the EOTA TR 034: "General Checklist for ETAGs/CUAPs/ETAs -Content and/or release of dangerous substances in products/kits", which have to be considered will be verified by the given methods taking into account the installation conditions of the construction product and the release scenarios resulting from there. Regulations related to placing the product on the market may also need to be taken into account.

Regarding the release scenarios referred to in the EOTA TR 034, the following use categories have to be considered:

Category IA1: Product with direct contact to indoor air

Category IA2: Product with no direct contact to (e.g. covered products) but possible impact on indoor air

Category IA3: Product with no contact to and no impact on indoor air

Category S/W1: Product with direct contact to soil-, ground- and surface water

Category S/W2: Product with no direct contact to but possible impact on soil-, ground- and surface water

Category S/W3: Product with no contact to and no impact on soil-, ground- and surface water

Categories IA1 and S/W1 are applicable for products which are in contact with indoor air, soil or water in a way that dangerous substances could be released directly out of the product.

Category IA2 is applicable for products which are covered with other products but nevertheless could release dangerous substances to indoor air (e.g. products covered with porous/unsealed coverings incapable of avoiding migration).

Category S/W2 is applicable for products which can be leached by rain and could release dangerous substances which can have impact on soil and water.

Categories IA3 and S/W3 are applicable for products which are completely covered with tight products capable of avoiding any kind of migration of dangerous substances to indoor air, soil or water.

Note that all content restrictions have to be considered in all cases.

5.3.2 Water vapour permeability

See clause 5.6.2.

5.4 Safety in use

The requirements of this Essential Requirement are covered by the clauses 5.7.2.1, 5.7.2.2 and 5.7.2.6.

5.5 Protection against noise

See Part 1 "General", clause 5.5.

5.6 Energy economy and heat retention

5.6.1 Thermal insulation

In addition to tabulated values, see Part 1 "General", clause 5.6, the following methods may be used to determine thermal insulation.

5.6.1.1 Method for mineral wool based renderings (Annex F)

5.6.1.1.1 Lambda fractile value at 10 °C, at dry conditions

The lambda fractile value at 10 °C, at dry conditions ($\lambda_{10,dry,90/90}$), representing at least 90 % of the production with a confidence limit of 90 % shall be stated in the ETA.

5.6.1.1.2 Moisture conversion factor ($f_{u,1}$)

The moisture conversion factor ($f_{u,1}$) for the conversion of $\lambda_{10,dry}$ to $\lambda_{23,50}$ shall be declared in the ETA.

5.6.1.1.3 Lambda declared at 23 °C and 50 % relative humidity $\bar{u}_{D(23,50)}$

The calculated value of the lambda declared at 23 °C and 50 % relative humidity shall be stated in the ETA.

5.6.1.1.4 Conversion factor to high moisture content ($f_{u,2}$)

The conversion factor to high moisture content ($f_{u,2}$), and the moisture content mass by mass (m/m) at 23 °C and 50 % relative humidity and 23 °C and 80 % relative humidity shall be given in the ETA.

It shall be stated in the ETA that in the value of the lambda declared at 23°C and 50% relative humidity the

influence of moisture has been taken into account.

5.6.1.2 Method for renderings other than those based on mineral wool

The determination of the thermal conductivity of renderings not covered by clause 5.6.1.1 shall be determined in accordance with one of the two following methods:

- a) EN 1745:2002, clause 4.2.2

The design value shall be determined in accordance with EN 1745:2002, clause 4.3.

It shall be stated in the ETA that the intended use of the product is restricted to places not exposed to wetting or weathering.

NOTE 8: However, in certain cases it may be necessary to know the influence of high moisture content in relation to the declared lambda value at 23 °C and 50 % relative humidity ($\lambda_{D(23,50)}$). This conversion factor to high the moisture content ($f_{u,2}$) then should only be seen as an information.

- b) method according to clause 5.6.1.1 (same method as for mineral wool based renderings)

5.6.2 Water vapour permeability

The water vapour transmission coefficient shall be determined on the basis of tabulated values in conformity with EN 12524:2000.

Where the ETA-Applicant claims specific water vapour transmission coefficient values, these shall be tested in accordance with EN ISO 12572, EN 12086 or similar European standards which are based on the same principle.

5.7 Related aspects of durability, serviceability and identification

5.7.1 Durability

5.7.1.1 General

The following verification methods shall be applied to the rendering, including if used, any mechanical fixings which are intended to be used as a part of a kit or "assembled system", unless similar tests have been performed on the basis of European product standards or European Technical Approvals. The need to conduct each of the following tests is determined by the claimed exposure and environmental conditions for the product or system as given in Table 5.2.

Durability is demonstrated by comparing the performance of unexposed specimens with specimens subjected to artificial ageing. The appropriate tests for the intended exposure types are given in Table 5.2. The references are to the detailed test requirements given in Annex E. The test indicated in E.9 of Annex E shall also be used to compare the insulation efficiency of the rendering with additional primers and different top coats, if relevant.

Table 5.2: Test requirements for different exposure types

Use categories (2.2.2)	UV	Moisture		Temperature (high/low)	Freeze/thaw
		Rain	High humidity		
X	Yes*, E.3	Yes, E.4	Yes, E.5	Yes, E.6	Yes, E.7a
Y	No	No	Yes, E.5	Yes, E.6	Yes E.7b
Z ₁	No	No	Yes, E.5	No	No
Z ₂	No	No	No	No	No

* only necessary for renderings with top coats of organic composition or such with organic binder or aggregates.

5.7.1.2 Resistance to UV exposure

This exposure condition is a requirement for renderings claimed to be suitable for type X climatic conditions. The test method is given in Annex E, E.3.

5.7.1.3 Resistance to deterioration caused by heat and rain

This exposure condition is a requirement for renderings claimed to be suitable for type X environmental conditions. The test method is given in Annex E, E.4.

5.7.1.4 Resistance to deterioration caused by high humidity

This exposure condition is a requirement for renderings claimed to be suitable for types Y and Z₁ environmental conditions. The test method is given in Annex E, E.5.

5.7.1.5 Resistance to deterioration caused by heat and cold

This exposure condition is a requirement for renderings claimed to be suitable for types X and Y environmental conditions. The test method is given in Annex E, E.6.

5.7.1.6 Resistance to deterioration caused by freezing and thawing

This exposure condition is a requirement for renderings claimed to be suitable for types X and Y environmental conditions. The test method for type X is given in Annex E, E.7a. The test method for type Y is given in Annex E, E.7b.

5.7.1.7 Resistance to corrosion of a steel substrate induced by the rendering

If the rendering is claimed by the ETA applicant to be suitable for direct application to un-primed steel, an assessment of the compatibility with and protective ability to the steel shall be made using the test method given in Annex C.

If a primer is part of the kit, and is claimed to provide corrosion protection, then the performance of the primer shall be proven by tests according to EN ISO 12944-6:1998.

5.7.1.8 Resistance to corrosion of the fixings induced by the rendering

Any fixing shall be contained entirely within the thickness of the rendering and therefore it will not be exposed to environmental conditions after installation. The fixings shall, however, be shown to be compatible with the rendering and not exhibit any adverse reaction. Since the suitability of fixings will depend on the chemical nature of the rendering, no specific test method can be prescribed. The Approval Body shall determine what is required to establish compatibility.

For galvanised steel reinforcement, the minimum thickness of zinc coating required is verified using the relevant EN method: EN ISO 1460 or EN ISO 1461.

5.7.2 Serviceability

5.7.2.1 Mechanical resistance and stability

The following tests for fixings are designed to define the minimum values required for the rendering system to achieve its designed performance. The tests for fixings are designed for metallic fixings. For non-metallic fixings or non-metallic reinforcement, additional assessment may be required. Fixings may either be discrete fixings or fixings used to secure keying or reinforcing mesh.

5.7.2.1.1 Pull off resistance of discontinuous fixings (into timber, masonry and concrete)

This test method shall be carried out for mechanically fixed systems only and establishes the pull-off resistance of a fixing system. This test shall be conducted on each substrate (including different types of concrete, softwood and hardwood, and masonry) for which the rendering is intended to be used and for each type of fixing.

For each substrate and fixing type, 5 samples are tested. The minimum sample size shall be 300 mm x 300 mm.

The apparatus consists of a dynamometer.

The fixing system is installed in accordance with the ETA-Applicant's specifications.

The tensile strength for pulling out the fixing shall be measured with a dynamometer. The tensioning speed is (20 ± 2) mm/min.

The pull-off resistance of each test is expressed in N. The test results, the mode of failure and mean value are recorded in the test report.

5.7.2.1.2 Bending resistance of discontinuous fixings (for steel)

These tests shall be carried out to confirm the bending resistance of fixings on each type of steel substrate to which the rendering kit is to be applied.

For “Straight fixing welded pins”, a purpose made tool (100 mm in length) shall be provided to sleeve over the fixing “pin”, leaving a gap of 15-20 mm between the end of the tool and the surface of the steel. The tool shall be bent to an angle of 45 ° and back to vertical without any failure of the pin or weld, see Figure 5.1. This shall be repeated on no less than 10 fixings without failure.

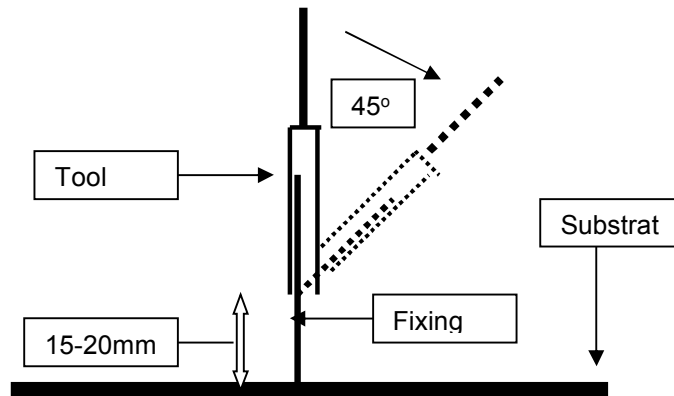

Figure 5.1 – Schematic of bending test for fixing pins

For “Helical welded pins”, a purpose made tool shall be used to twist the fixing through 90 ° and back without any failure of the pin or weld. This shall be repeated on no less than 10 fixings without failure. The tool is required to engage the top portion of the fixing in such a way as to allow the twisting motion required.

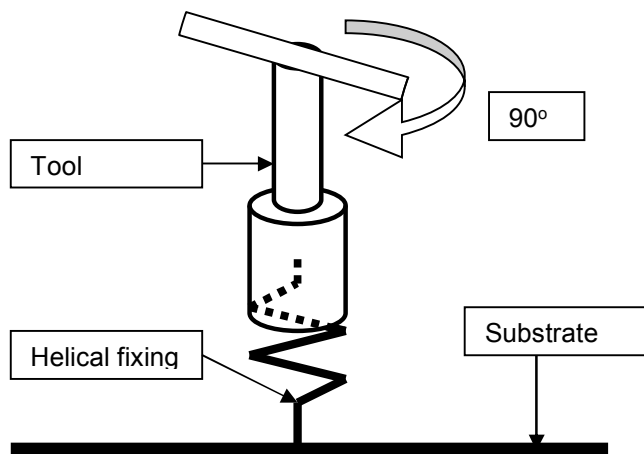

Figure 5.2 – Schematic of bending test for fixing pins

Fixings different from the types described above shall be tested following the principles of the two methods above. In addition to being an approval test to define the approved specification, this method, being non-destructive, is also suitable for use on site to check the efficacy of the fixings.

5.7.2.1.3 Pull off resistance of keying mesh

This test is to be carried out to test the weld strength (pull off resistance) of expanded metallic meshes where these are resistance welded to the substrate.

A "T - shaped" tool shall be inserted under the mesh adjacent to the welded strands so as to straddle two strands of the mesh aperture. A load is applied normal to the plane of the mesh and is measured with a simple spring balance. The load values in N are recorded.

5.7.2.1.4 Pull off resistance of rendering

This characteristic is addressed under clause 5.7.2.6

5.7.2.2 Resistance to impact / movement

5.7.2.2.1 Resistance to functional failure from hard body impact load – 0,5 kg steel ball

The need to evaluate the resistance to hard body impact is restricted to products intended to be used in applications where hard body impact to the rendering is likely to occur and for which impact resistance is claimed. Tests are not required where the rendering is protected by independent mechanical means.

If tests are not performed, the ETA shall limit the applications to those where impact will not occur.

Tests are not required to be conducted on structural steel sections provided that the material is continuously bonded to the steelwork, unless a top coat is used to improve impact resistance.

If the conditions above do not apply, the test shall be conducted in accordance with the test method as specified in EOTA Technical Report TR 001, for serviceability characteristics with the following modifications:

- a) For flat or essentially flat large surfaces the test sample shall be a section of substrate of minimum dimensions 1 m × 1 m.
- b) For flat, or essentially flat, large surfaces the impact resistance shall be measured both at fixing points, if any, and between fixings.
- c) For evaluation on structural steelwork the test sample shall be a section of steel rhs column of nominal size 1m long of section size 200 mm × 200 mm by 165 A/V. The rendering shall be mixed and sprayed in accordance with the ETA-Applicant's specification and incorporating the appropriate mechanical fixings, if any, as specified. The test shall be repeated at the minimum thickness of rendering for each intended type of substrate, variation of fixings, including no mechanical fixings if appropriate, and for each fixing pattern. If the worst case fixings and fixing pattern is able to be identified only the worst case need be tested.
- d) For structural steelwork the impact resistance shall be measured at three points determined to be the weakest points, e.g. at corners and ends of flanges.

The height of the ball before the release shall depend on the claims made by the ETA-Applicant.

The sample shall be inspected for visible signs of damage (cracking, spalling or delamination from the substrate) and the dimensions of any detached pieces measured.

The test report shall show the impact resistance (energy in Nm) that the system resisted without visible damage. The test report shall record all visible damage sustained at higher impact levels.

5.7.2.2.2 Resistance to functional failure from soft body impact load – 50 kg bag

The need to evaluate the resistance to soft body impact is restricted to products intended to be used in applications on large flat vertical surfaces (greater than 1 m by 1 m) in zones where soft body impact is likely to occur. If tests are not performed, the ETA shall limit the applications to those where impact will not occur. Tests are not required to be conducted on structural steel sections provided that the material is continuously bonded to the steelwork.

Separate tests shall be conducted on each type of substrate for which the rendering is intended to be used, except that the results of tests conducted on rendering applied to sheet steel may be applied to all other substrates defined in this ETA-Guideline. The steel sheet shall be of the minimum thickness for which the rendering is suitable and the steel shall be supported as it would be in practice.

The test method is specified in EOTA TR 001 with the following modifications:

The test sample shall be a section of substrate of minimum dimensions 1 m × 1 m. The rendering shall be mixed and sprayed in accordance with the ETA-Applicant's specification and incorporating the appropriate mechanical fixings, if any, as specified. The test shall be repeated for each intended type of substrate, maximum and minimum thickness of rendering, variation of fixings, including no mechanical fixings if appropriate, and for each fixing pattern. If the worst case fixings and fixing pattern can be identified only the

worst case need be tested.

The bag is suspended at a specified height above the impact point and released. The point of impact shall be the centre of the sample.

The height of the bag before the release shall depend on the claims made by the ETA-Applicant. To prevent progressive damage from influencing the test results, the impact resistance test shall always be conducted on new assemblies.

The sample shall be inspected for visible signs of damage (cracking, spalling or delamination from the substrate) and the dimensions of any detached pieces measured.

The test report shall show the impact resistance (energy in Nm) that the system resisted without damage. The test report shall record all visible damage sustained at higher impact levels.

5.7.2.3 Air erosion

In applications where the rendering is subject to air movement, such as in a plenum or ducting, the erosion of the material shall be evaluated in accordance with the test method given in Annex D.

The evaluation of erosion by air is only required for applications where the rendering is intended to be subjected to higher than normal air flow such as would be experienced in a duct or plenum used to carry air. If tests are not performed, the ETA shall limit the applications to those where the rendering is not subjected to higher than normal airflows.

5.7.2.4 Water vapour permeability

The test specified in clause 5.6.2 is also applicable for serviceability.

5.7.2.5 Water absorption (capillarity test)

This test need only be performed for intended use category type X and if the intended use involves conditions, such as contact with the ground, which would make capillarity relevant. In that case the method given in ETAG 004 for ETICS shall be used. If tests are not performed, the ETA shall limit the applications to those where capillarity will not occur.

5.7.2.6 Adhesion (bond strength)

The following tests are designed to establish the minimum values required for the rendering to achieve the requisite fire performance. See clause 5.0.2 regarding sample preparation for tests which in the case of adhesion (bond strength) may alternatively be conducted on the fire test sample itself. It is assumed that adhesion (bond strength) adequate for fire performance will also be appropriate for serviceability. As a minimum, a value for adhesion (bond strength) shall be determined at the minimum and maximum intended rendering thicknesses. Most timber structures require supplementary fixing but, if no fixings are used, the adhesion (bond strength) shall be tested as for other substrates.

The adhesion (bond strength) of renderings which do not incorporate either a keying or reinforcing mesh shall be determined. Examples of suitable test methods are EGOLF method EA 5 or EN 1015-12 and particularly for low adhesion products, ASTM E 736.

For renderings which incorporate a continuous keying or reinforcement mesh there is no requirement for testing since it is assumed that the reinforcement is independently fixed to the substrate and the fixings are evaluated separately.

NOTE 9: Testing of adhesion (bond strength) is mandatory because it is essential that a minimum value of bond strength for fire resistance is established for every substrate.

When conducting adhesion (bond strength) tests, the following points shall be observed:

- a) Minimum and maximum rendering thicknesses shall be measured.
- b) Specimens of renderings based on mineral wool fibres are very sensitive to cutting but it is possible, if done with special care and adequate tools.
- c) The bonding shall ensure that the whole surface of the rendering is fixed to the circular steel plate. Usually, fire protective renderings based on mineral wool show irregular surfaces, which can lead to an inefficient bonding of the circular steel plate. Therefore, in order to ensure a good bonding, the necessary amount of adhesive (in accordance with the ETA-Applicant's specification) shall be spread over the rendering surface to fill all the irregularities. Next, the steel plate shall be put on the

test specimen and shall be pressed slightly to avoid damage on the test specimen.

Before performing the test, it is necessary to check that no adhesive has penetrated inside the cut between the test piece and the surrounding material.

- d) Load rate. In accordance with the test method, tensile force shall be applied to the test piece, manually or automatically, at a steady rate according to the performance rating of the load cell (capacity 1 kN to 10 kN), or by a steady application of increasing dead weights. The load applying device (tensiometer or dead weights system) shall be able to apply loads from almost 0 kN. The load rate shall be adequate for the tested material. It shall be recorded and specified in the test report.
- e) Test specimen dimensions may need to be smaller than specified in the test method, for example because of the specimen profile (re-entrant or trapezoidal profiles, see figure 5.3), because of weight considerations or to fit test apparatus at laboratories.

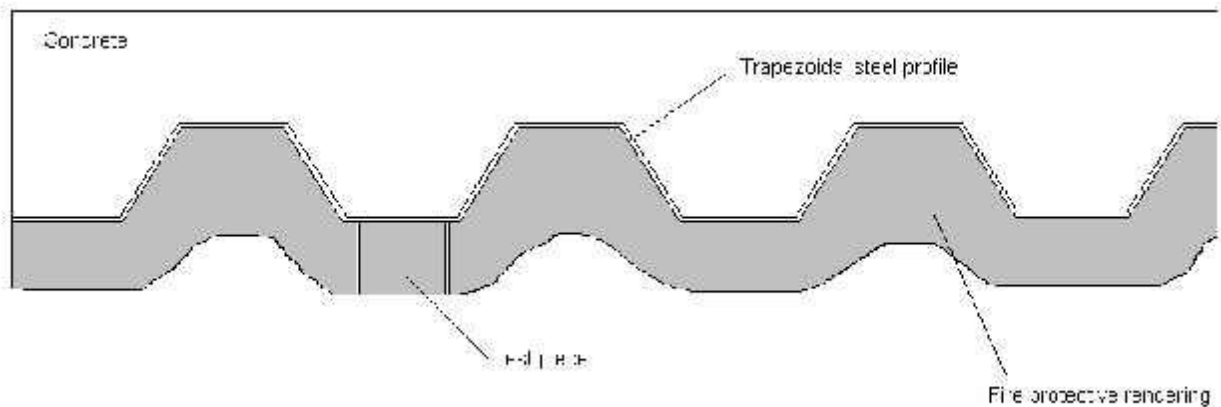

Figure 5.3
Sampling for trapezoidal steel profiles

NOTE 10: Failure in the test will be either adhesive or cohesive, depending on which is weaker. It is not possible to predetermine the mode of failure and accordingly not possible to measure bonding between different layers by design.

For renderings which incorporate discontinuous fixings, the fixings shall be tested in accordance with clause 5.7.2.1.

5.7.3 Identification

Regardless of which option is chosen for the rendering or the rendering kit (see Foreword) products, components and materials used in fire protective rendering shall be identified, either through verification methods specified in a European product standard, a European Technical Approval or as detailed in this Guideline. See Part 1 “General”, 5.7.2.

Table 5.3 includes examples of methods which may be used. Methods adopted shall be appropriate to the type of rendering being evaluated and be agreed with the Approval Body. Ancillary components including additives shall be identified by reference to name, reference codes, formulation, ETA holder, compliance with the relevant EN, corrosion protection, dimensions or other appropriate means. When any additional components are supplied as part of a kit, the rendering producer shall obtain a declaration of conformity from the supplier with the agreed specification.

Table 5.3: Testing for identification

Properties	Dry mix	Fresh mortar	Rendering	Bonding agent primer/s, top coat/s	Reinforcement/s	Fixings
Description	X		X	X		
Formulation, or fingerprint, providing the following information: binder and pigment content, infrared spectra, non-volatile matter by mass	X			X		
Fingerprint ⁹	X			X		
Mixing ratio (if applicable)		X		X		
Colour (visual verification)	X		X	X		
Particle size (grading) ¹⁰ ,	X					
Fibre type length and aspect ratio (mineral wool only)	X					
Density: - Mean density (dry mix) - Bulk density (fresh mortar) - Density (hardened mortar)	X	X	X			
Density (relevant part of EN ISO 2811, determined at (23 ± 2) °C and (50 ± 5) % RH)				X		
pH value		X		X		
Dry extract (105 °C)	X			X		
Ash content (450 °C or 900 °C)				X		
Flexural and compressive strength of hardened mortar (e.g. EN 1015-11)			X			
Volatile organic components (VOC) (ISO 3233, determined at (23 ± 2) °C and (50 ± 5) % RH)				X		
Nominal film thickness				X		
Description of the component (incl. corrosion resistance)					X	X
Geometry					X	X
Tensile strength					X	X

⁹ If "Fingerprinting" is used, for most products FTIR (Fourier Transform Infra -Red Spectroscopy), TGA (Thermo-Gravimetric Analysis) or DTA (Differential Thermal Analysis) will be appropriate. X-ray diffraction may also be considered.

¹⁰ For fibrous materials: fibre-diameter/length/aspect ratio e.g. for mineral wool.

6 ASSESSING AND JUDGING THE FITNESS OF PRODUCTS OR KITS FOR INTENDED USE

6.0 General

The assessment and judging shall be performed in accordance with Part 1 "General", Chapter 6, except where modified or specified below.

Unless other specifications have been given in this chapter, extended application of the test result (if any) shall be declared in the ETA, under the responsibility of the Approval Body.

The Approval Body shall assess and judge the fitness for use of the product or kit for each characteristic that was verified. Every declaration in the ETA represents a favourable assessment of the product's or kit's performance, made under the responsibility of the Approval Body, taking in to account the intended use.

The mean value of density of the resistance to fire test specimens shall be taken as the nominal value that together with a tolerance of $\pm 15\%$ representing the field of direct application shall be quoted in the ETA. A larger upper tolerance may be able to be established based on further consideration of the implications of increased mass. This constitutes a field of extended application (see also 9.1.4).

6.1 Mechanical resistance and stability

Not relevant for these products, see Part 1 "General", 6.1.

6.2 Safety in case of fire

See Part 1 "General", 6.2.

6.2.1 Reaction to fire

The fire protective rendering shall have a declared fire reaction classification, in accordance with EN 13501-1.

6.2.2 Fire resistance

The fire resistance shall be classified in accordance with EN 13501-2 and/or EN 13501-3 as appropriate and shall specify the elements (substrate) to be protected and the specification of those elements, e.g. the steel section.

Because a rendering does not possess fire resistance in its own right, the classification applies to the protected element, including the rendering, and not to the protection itself.

The ETA shall include the characterization data and the field of application.

6.3 Hygiene, health and the environment

See Part 1 "General".

6.3.1 Content and/or release of dangerous substances

The product and/or constituents of the product listed in the EOTA TR 034: "General Checklist for ETAGs/CUAPs/ETAs Content and/or release of dangerous substances in products/kits" (or equivalent EOTA document), and the related dangerous substances which have to be considered, will be assessed by the given methods taking into account the installation conditions of the construction product and the release scenarios resulting from there.

6.3.2 Water vapour permeability

See clause 6.6.2

6.4 Safety in use

See clause 5.4

6.5 Protection against noise

See Part 1 "General", 6.5.

6.6 Energy economy and heat retention

6.6.1 Thermal insulation

See Part 1 "General", 6.6.

The tabulated or measured value of the thermal resistance or thermal transmittance shall be declared.

6.6.2 Water vapour permeability

The water vapour transmission coefficient shall be declared.

6.7 Related aspects of durability, serviceability and identification

6.7.1 Durability

6.7.1.1 General

- working life of 25 years:

This shall be the favourable assessment for the relevant complete durability verification of the rendering. The relevancy depends on the intended use based on the environmental conditions and will be possible for new products if

- a satisfactory performance for the declared exposure category is available or
- the intended use is restricted to use category type Z₂

- working life of 10 years:

If a satisfactory performance of the product is not established in the durability verification tests then an estimated working life of 10 years may be attributed based on the applicant's demonstration of the satisfactory use of the rendering system for a period of 10 years in the environmental conditions claimed.

6.7.1.2 Resistance to UV exposure

Relevant for use category type X.

After exposure to the conditions prescribed in clause 5.7.1.2 the adhesion (bond strength) shall be not less than 80 % of that achieved by the unexposed samples. Where the result falls outside this criterion, four additional specimens may be exposed, tested and assessed. All four specimens shall fulfil the pass criteria.

6.7.1.3 Resistance to deterioration caused by heat and rain

Relevant for use category type X.

After exposure to the conditions prescribed in clause 5.7.1.3 the adhesion (bond strength) shall be not less than 80 % of that achieved by the unexposed samples nor shall the insulation efficiency be less than 85 % of the mean value of the unexposed samples. Where the result falls outside these criteria, four additional specimens may be exposed, tested and assessed. All four specimens shall fulfil the pass criteria.

6.7.1.4 Resistance to deterioration caused by high humidity

Relevant for use categories types Y and Z₁.

After exposure to the conditions prescribed in clause 5.7.1.4 the adhesion (bond strength) shall not be less than 80 % of that achieved by the unexposed samples nor shall the insulation efficiency be less than 85 % of the mean value of the unexposed samples. Where the result falls outside these criteria, four additional specimens may be exposed, tested and assessed. All four specimens shall fulfil the pass criteria.

6.7.1.5 Resistance to deterioration caused by heat and cold

Relevant for use categories types X and Y.

After exposure to the conditions prescribed in clause 5.7.1.5 the adhesion (bond strength) shall be not less than 80 % of that achieved by the unexposed samples nor shall the insulation efficiency be less than 85 % of the mean value of the unexposed samples. Where the result falls outside these criteria, four additional specimens may be exposed, tested and assessed. All four specimens shall fulfil the pass criteria.

6.7.1.6 Resistance to deterioration caused by freezing and thawing

Relevant for use category type X and type Y.

After exposure to the conditions prescribed in clause 5.7.1.6 the adhesion (bond strength) shall be not less than 80 % of that achieved by the unexposed samples nor shall the insulation efficiency be less than 85 % of the mean value of the unexposed samples. Where the result falls outside these criteria, four additional specimens may be exposed, tested and assessed. All four specimens shall fulfil the pass criteria.

6.7.1.7 Resistance to corrosion of the substrate induced by the rendering

The value of loss of mass shall be declared. The 'No performance determined' option is permitted.

6.7.1.8 Resistance to corrosion of the fixings induced by the rendering

Compatibility of the fixings and rendering is established by the particular test for the specific fixing/rendering combination.

For galvanized fixings/reinforcement the thickness of zinc coating shall be declared.

6.7.1.9 Demonstration of experience of 10 years favourable performance

If the ETA-Applicant uses the option of providing documented proof that the product has been used satisfactorily for at least 10 years, the ETA shall specify which evidence was presented to the Approval Body. The Approval Body may restrict the use of the product as specified in the ETA and the decision shall be dependent on the composition of the product having not changed significantly in the 10 year period. If the Approval Body considers the evidence provided as sufficient, the working life as specified in the ETA shall be 10 years. The evidence provided becomes part of the Approval Body's confidential file.

6.7.2 Serviceability requirements

See Part 1 "General", clause 6.7.

Durability characteristics identified in clause 6.7.1 can also be used for the purpose of defining serviceability.

6.7.2.1 Mechanical resistance and stability¹¹

6.7.2.1.1 Pull off resistance of discontinuous fixings (into timber, masonry and concrete)

The value, expressed in N, shall be quoted in the ETA.

6.7.2.1.2 Bending resistance of discontinuous fixings (on steel)

The value, expressed in N, shall be quoted in the ETA.

6.7.2.1.3 Pull off resistance of keying mesh

The value, expressed in N, shall be quoted in the ETA.

6.7.2.1.4 Pull off resistance of rendering

See clauses 5.7.2.1.4, 5.7.2.6 and 6.7.2.6.2

6.7.2.2 Resistance to impact / movement

6.7.2.2.1 Resistance to functional failure from hard body impact load – 0,5 kg steel ball

The value of impact energy, expressed in Nm, sustained without damage shall be declared.

The 'No performance determined' option is permitted.

6.7.2.2.2 Resistance to functional failure from soft body impact load – 50 kg bag

The value of impact energy, expressed in Nm, sustained without damage shall be declared.

The 'No performance determined' option is permitted.

6.7.2.3 Air erosion

The value as the loss of mass, expressed in g/m²/24h, shall be declared.

¹¹ For products which do not contain any fixing or keying mesh the requirements of 6.7.2.1 to 6.7.2.3 are not relevant.

The 'No performance determined' option is permitted.

6.7.2.4 Water vapour permeability

The measured or tabulated value of the water vapour transmission coefficient (μ -value) shall be declared.

The 'No performance determined' option is permitted.

6.7.2.5 Water absorption (capillarity test)

The water absorption of the rendering system after one hour shall be less than 1 kg/m².

The 'No performance determined' option is permitted.

6.7.2.6 Adhesion (bond strength)

6.7.2.6.1 Bond strength

For renderings which do not include reinforcement or discontinuous fixings, the bond strength, expressed in N/mm², shall be declared for every substrate tested. 'No performance determined' is not permitted.

A value for the adhesion (bond strength) of the rendering to the substrate shall be established since it is necessary to determine the exact conditions under which the fire resistance is achieved.

6.7.2.6.2 Pull-off resistance of the fixings

For renderings which rely on discontinuous fixings the bending resistance or pull-off resistance of the fixings shall be declared (see 6.7.2.1).

6.7.2.6.3 Continuous keying

No value is required for renderings which incorporate a continuous keying or reinforcement mesh.

The 'No performance determined' option is therefore permitted.

6.7.3 Identification

Products and materials used in fire protective renderings and kits shall be identified, either by the means specified in a European product standard, a European Technical Approval or as specified in this Guideline.

The rendering shall be characterized by appropriate means from the options used in 5.7.3 to declare values and tolerances.

7 ASSUMPTIONS AND RECOMMENDATIONS UNDER WHICH THE FITNESS FOR USE OF THE PRODUCTS IS ASSESSED

7.0 General

This chapter sets out the assumptions and recommendations for design, installation and execution, packaging, transport and storage, use, maintenance and repair under which the assessment of the fitness for use according to the ETA-Guideline can be made (only when necessary and in so far as they have a bearing on the assessment or on the products).

7.1 Design of works

See ETA-Guideline Part 1 "General".

Fire protective renderings and kits shall be assessed under the presumption that the element being protected, the substrate, is suitable for the rendering to be used in the way intended and in full compliance with the ETA such that when installed in the prescribed manner the works will comply with all relevant Essential Requirements.

The Approval Body shall assess the risks involved and, if deemed necessary, carry out relevant tests from those described in Chapter 5 or foresee limitations in order for the rendering or rendering kit to be fit for application in the intended use.

An ETA holder may place on the market bags of dry mix only, for use without any additional components such as fixings or reinforcement (this is 'Option 1' as defined in clause 2.1). Any other components required to be used but supplied by others, e.g. fixings, mesh, additives, shall be specified in the ETA according to the available technical specifications (e.g. EN or ETA), and when it is not possible by reference to

proprietary items, physical dimensions and material performance or by compliance with relevant product specifications (this is 'Option 3' as defined in clause 2.1). It is therefore assumed that in designing the works the correct components will be used.

Alternatively an ETA applicant may place on the market bags of dry mix plus one or more other components such as bonding agent, reinforcing mesh, fixings and additives. This constitutes a 'kit' and in this case the ETA covers the 'kit' and the ETA applicant is responsible for both the specification and compliance with specification of all the components he supplies as part of the kit (this is 'Option 2' as defined in clause 2.1). It is assumed that the design of the works will accommodate the kit as supplied and that the kit will be installed as specified.

It is assumed that the possible effect of other fire protection measures, such as sprinklers, on the rendering will be taken into account in the design of the building.

It is assumed that where the works may be subject to say, vibration either during the construction or during use that precautions will be specified, for example the use of a keying or reinforcement mesh.

Biological attack

In rare cases, deterioration of these products may occur due to biological attack, i.e. mould growth on the products and/or the products being subject to deterioration due to insects or mammals infestation. This ETA-Guideline does not foresee product assessment for resistance to biological attack, but where Approval Bodies expect biological attack to be of particular importance for specific products, additional, case-by-case assessment shall take place (see clause 4.7.1.1).

Moulds and other fungi that may damage products require warm (10 °C to 35 °C), humid conditions (relative humidity > 70 %), and a suitable food source. Mould growth is encouraged by dark conditions and lack of air movement. Design solutions shall prevent the possibility of mould growth by ensuring that areas where these products are used can be ventilated sufficiently. Users shall ensure that adequate ventilation is provided to discourage mould and fungal growth.

Proper water tightness of the building envelope, using appropriate design principles and details are essential. During the exposed and partially enclosed phases of construction, to minimize the potential for mould growth, it is important to minimize the risk of water damage and wet surfaces due to external factors such as rain, snow, flooding, and high relative humidity. During construction, the following shall be considered to minimize the potential for mould growth: minimizing the exposure of interior building products to exterior conditions; protecting stored materials from moisture; minimizing moisture accumulation within the building; preventing spillage of water within the building; maintaining the integrity of the building envelope components through ongoing monitoring and inspections; achieving balance control of thermal comfort and relative humidity in the building; checking all material deliveries to validate that components are dry and clean; rejecting wet or mouldy materials, and monitoring installations to ensure they remain clean and dry (including heating, ventilation and air conditioning systems).

In addition, where animals (insects or mammals) might attack these products, design solutions shall prevent animal access to places where the products have been used and habitable voids that might harbour animals shall be either avoided or sealed.

7.2 Packaging, transport and storage

It is assumed that the ETA holder takes suitable precautions to limit the risk of damage or deterioration during transport and storage.

7.3 Execution of works

It is assumed the site environmental conditions of exposure, temperature and humidity will be within the parameters prescribed for the application of the rendering.

Rendering systems intended for indoor applications may be temporarily exposed before the building envelope is closed. If the rendering is able to sustain short term exposure this shall be stated in the ETA and recommendations shall be given as to how to deal with this situation. This shall include, for example, how to dry the material if it has become wet; details of inspection required for cracks, delamination and mould growth; details of measurement of thickness and adhesion (bond strength) and a procedure for patch repair of damaged areas.

It is also assumed that the elements (substrates) to be protected are suitably prepared to the requirements specified in the ETA and, where appropriate, a suitable primer applied.

The primer used in the approval tests shall be specified in the ETA. The ETA may also include

generic/primer families for which the compatibility and adhesion (bond strength) have been proved by testing.

Where rendering is to be applied on steel that is already primed, the compatibility of the primer shall be established. If its identification or generic type is not known the adhesion between the primer and rendering with a bonding agent, if used, shall be tested.

For cement-rich primers the pH value of the primer to be used shall be tested and be within the limits prescribed for the rendering.

The ETA-Guideline is not designed to cover the application of rendering over any existing coating (e.g. 'old existing paint') or rendering. It is therefore assumed that:

- a) any existing coating or rendering is completely removed, or;
- b) if it is not removed, that the compatibility and adhesion (bond strength) between the new rendering and the existing coating or rendering is not less than 80 % of that which would exist between the new rendering and the substrate, or;
- c) mechanical fixing is employed e.g. a keying mesh secured independently of the existing coating or rendering direct to the substrate.

It is assumed that there is no contribution to performance from the existing substrate.

It is assumed that special attention will be paid to any additives required to be used with the rendering. In particular their specification, quantity, ratio and conditions of use as specified in the ETA and in the ETA applicant's instructions shall be considered.

Preparation of the product and its application is critical to the performance of renderings and their ability to fulfil the Essential Requirements. The ETA holder shall provide comprehensive installation instructions which shall clearly identify the installation criteria for the rendering or rendering kit together with training requirements for operatives. These shall accompany the product or associated documentation and contain, as a minimum, the information specified in 9.1.4 Installation and 9.1.5 Maintenance and repair.

7.3.1 Site tests

Where fixings are required to be used the evaluation tests of pins and keying mesh prescribed in 5.7.2.1.1, 5.7.2.1.2 and 5.7.2.1.3, being non-destructive, are appropriate to use as quality control tests on site to check the efficacy of fixings and are recommended to ensure that the same performance is achieved in practice as was type tested.

Where the rendering is self-bonded to the substrate without fixings the method described in 5.7.2.6.1 is appropriate to ensure that at least 80 % of the value of the bonding is achieved in practice as was type tested.

The thickness shall be measured at a frequency sufficient to determine the mean and minimum thickness. A suitable method for thickness measurement is given in 5.0.2 (for non-fire tests).

The density of the rendering shall be measured by a method recommended by the ETA holder. It shall be within the tolerances specified in the ETA. Suitable methods to measure the density are given in clause 5.0.2. If EN 1015-6 and EN 1015-10 will be used, the number of samples may be reduced to an appropriate level. Other methods may be applied.

When some renderings dry and cure, a certain amount of shrinkage of the material inevitably occurs with resultant cracking. Within limits this behaviour is acceptable. Hairline cracks are acceptable up to the size and number of those recorded in the fire test samples before testing. The maximum degree of cracking permitted for a rendering shall be included in the ETA.

7.4 Maintenance and repair

See Part 1 – "General".

Renderings can generally be repaired, when there are small areas of damage caused by accident or disruption by other trades. The requirements for the repair: shape and maximum size of repair, preparation, the material, fixings, reinforcement and the method of application shall be specified in the instructions. Particular attention shall be paid to the difficulties in bonding the repair to old rendering.

7.5 Auxiliary components

See Part 1 – "General".

Section three: ATTESTATION OF CONFORMITY

8 ATTESTATION OF CONFORMITY

8.1 EC-decision

The EC-decision is given in Part 1 “General”, 8.1.

8.2 Responsibilities

Unless modified or supplemented below, the responsibilities are given in Part 1 “General”, 8.2.

8.2.1 Tasks for the ETA holder

8.2.1.1 Factory Production Control (FPC)

See Part 1 “General”.

8.2.1.2 Inspection and testing

8.2.1.2.1 General

The ETA holder remains responsible for the product and any components supplied as part of a kit although the ETA holder may not manufacture all or any of them. The ETA holder’s FPC system shall identify the evaluation to be conducted to ensure consistency of manufacture and equivalent confidence in all components together with who is responsible (e.g. supplier or ETA holder) for conducting the evaluation.

If the product or kit components are supplied to the ETA -holder, the supplier shall meet the requirements in Table 8.1 and the ETA-holder shall ensure conformity with the supplier’s declaration of conformity, by sample inspection of the incoming product or incoming components.

Supplier’s declarations of conformity shall correspond with the principles of EN ISO 17050-1 and -2.

8.2.1.2.2 Inspection and testing of kit components

Where the ETA holder offers a rendering kit the FPC shall address appropriate conformity testing or inspection of all items in the kit to ensure consistency of performance of the rendering¹². Batch sampling of components may be appropriate dependent on the volume of production of such items.

In circumstances where the kit components are manufactured on the ETA holder’s behalf, the FPC shall address sample inspection of incoming components. Where the material from which the components are made is critical to the component’s end use or a corrosion resistant coating may be required on the component in order for it not to create a detrimental effect on the primary product with which it is used, these criteria shall be addressed in the FPC. Where such criteria are critical to the overall performance of the kit, the ETA holder shall require declarations of conformity to accompany the externally manufactured components.

Where incoming material is released for urgent production purposes prior to verification it shall be identified and recorded in order to facilitate immediate recall in the event of non conformity.

8.2.1.2.3 Product testing

On-going semi-manufactured and finished product testing shall be carried out in accordance with the ETA holder’s documented FPC in order to verify continued conformity with the product specification. All materials, semi manufactured and finished products subject to testing and inspection shall be traceable through batch numbers or other ETA holder production references.

This production related testing shall be carried out by suitably trained / qualified personnel either directly employed by the ETA holder or by an external body acting on behalf of the ETA holder.

Records of all semi-manufacturing / finished product inspection and testing shall be traceable to raw material/ admix constituent conformity testing records.

¹² The constancy of the products also could be checked by other means, e.g. by checking the constancy of the formulation/composition (“Fingerprint”) of the product and of its production process.

8.2.1.2.4 Inspection and test status

The ETA holder's FPC shall detail the methods employed to demonstrate the inspection and test status of raw materials / admix constituents, semi manufactured product and finished product.

8.2.2 Tasks for the Notified Product Certification Body

8.2.2.1 Initial type testing of the product

See Part 1 "General".

8.2.2.2 Assessment of the factory production control system – initial inspection and continuous surveillance

See Part 1 "General".

The factory production control shall be subject to initial inspection by the Notified Product Certification Body and to continuing surveillance at a frequency of not less than twice a year to ensure continuing compliance with the ETA.

8.2.2.3 Certification of Conformity

The Notified Product Certification Body shall issue the Certification of Conformity of the product.

8.3 Documentation

The documentation is given in Part 1 "General", clause 8.3.

Table 8.1: Properties and ETA holder's Test Plan

No	Property	Relevant test method	Basis of acceptance	Minimum frequency of tests
Dry mix and top coat (manufactured by the rendering ETA holder)				
1	Incoming materials	Declaration of conformity	ETA holder's specification	Every batch supplied
2	Bulk density of aggregates		ETA holder's specification	Once per batch
3	Bulk density of dry mix		ETA holder's specification	Once per batch or five times per day (24 h) at regular intervals
Rendering (fresh mortar)				
4	Apparent density		As established in approval tests	Once per batch or five times per day (24 h) at regular intervals
5	Setting time/workability (pot life)		ETA holder's specification	Once per batch or five times per day (24 h) at regular intervals
Rendering (hardened mortar)				
6	Density		As established in approval tests	Once per month
7	Adhesion (bond strength) on substrate			Once per month
8	Insulation efficiency or any alternative test designed to ensure consistency of fire	Annex E.9	Time to reach 500 °C	Once per month

	performance (to be agreed between the AB, the NB and the ETA holder)			
Additional components				
9	Bonding agent Top coat (manufactured by others)	Agreed specification based on e.g. description, type of material, viscosity, pH value, colour, volatile content	ETA holder's specification	Every delivery
10	Fixings, lath and reinforcement	Agreed specification based on e.g. description, type of material, coating, dimensions, geometry, design	ETA holder's specification	Every delivery

8.4 CE-marking and information

The general requirements for CE marking and information instructions are given in Part 1 "General", clause 8.4.

The CE marking shall be applied to the immediate packaging (bag or container).

Kit components other than the bags of dry mix shall not be CE marked as a component of the kit which is the subject of the ETA but shall be described in detail in the documentation accompanying the bags of dry mix.

 xxxx
Any Company Rue du Producteur, 50 Country Xx xxxx-CPD-xxxx
ETA N° XX/XXXX ETAG 018, Parts 1 and 3 Fire Protective Rendering/Rendering Kit "XXX" See ETA for relevant characteristics

"CE"-marking

Number of Notified Product Certification Body

Name and address of the producer (legal entity responsible for placing the product onto the market)

Last two digits of year of affixing CE marking
Number of EC certificate of conformity (where relevant)

ETA Number

ETAG Reference and kind of product

Name of the product

Section four: ETA CONTENT

9 THE ETA CONTENT

9.1 The ETA-content

The requirements for the content of the ETA are given in Part 1 “General” , Chapter 9.

The ETA shall specify any components in addition to the product (dry mix) supplied or that may be supplied by the ETA holder as part of a kit and hence intended to be covered by the same CE Marking.

The specification of components supplied by other than the ETA holder shall also be specified in terms of their characteristics or by reference to proprietary details.

The ETA shall specify the results of the assessment.

The ETA shall identify an assumed working life for the cured rendering when in situ.

9.1.1 Identification of materials

See Part 1 “General”, clause 9.1.2.3.

9.1.2 Performance

See Part 1 “General”, clause 9.1.2.4.

In addition the ETA shall specify the required different thicknesses of rendering for different substrates and periods of fire resistance. It is recommended that for application to structural steel elements this is best expressed in the form of a matrix showing the section factor A/V versus the period of fire resistance.

- Dangerous substances

In section II.2 Characteristics of products and methods of verification, the ETA shall include the following text in the clause of dangerous substances:

According to the chemical constitution and composition of the product (or components of the kit) / the written declaration on dangerous substances [whichever applies] submitted by the ETA-holder to the Approval Body:

(...)¹³

In addition to the specific clauses relating to dangerous substances contained in this European Technical Approval, there may be other requirements applicable to the kit falling within its scope (e.g. transposed European legislation and national laws, regulations and administrative provisions). In order to meet the provisions of the EU Construction Products Directive, these requirements need also to be complied with, when and where they apply.

NOTE 11:

For dangerous substances falling under the scope of the CPD for which

- no assessment and verification methods are given (or cannot be found in TR 034) or
- “no performance determined” is declared or
- the chosen verification and assessment method does not comply with the regulatory requirement of a particular Member State

there might be the necessity for an additional assessment.

9.1.3 Drawings

See Part 1 “General”, clause 9.1.2.5.

9.1.4 Installation

The specification of components of the kit, e.g. fixings and reinforcement, shall be given together with a description of how they are used.

The installation / application instructions shall identify the minimum requirements for satisfactory installation of the product in respect of training, competence and / or experience.

¹³ For the expression of the assessment results on dangerous substances in the ETA, the Approval Bodies will follow the provisions given in Annex 1 to the Addendum to EOTA GD 001, March 2012, “Criteria for the ETA content of dangerous substances information”

Where the sale of the product is restricted by the ETA holder to specialist fire protection industry contractors this shall be clearly identified on the packaging in addition to inclusion in the installation instructions.

The instructions shall clearly identify the correct tools and equipment for application of the rendering or rendering kit in all of the various forms (clearly identifying equipment which may be additional to the "norm" for certain types of application).

The ETA shall state if a rendering intended for indoor or semi-exposed applications is approved to be temporarily exposed to outdoor conditions before the building envelope is closed. Instructions shall identify any special provisions such as; to temporarily protect the rendering or, for example, drying, adhesion testing and inspection requirements in the event of exposure.

The installation instructions shall clearly describe the method of installation of the product or kit including but not restricted to:

- storage conditions for the products, including the shelf life of the bagged product, and other components where relevant; the 'pot life', or 'workability' of prepared material and the time to full cure,
any substrate preparations required before application (including levels of substrate cleanliness, compatibility of the rendering with different substrates),
- any substrate key-coat / barrier coat which may be required in certain circumstances including the detailed instructions for mixing (as applicable), environmental conditions required for application and requirements for correct application,
- details of the requirements for primers on substrates and for the checking of compatibility with the rendering (by reference to pH, for example) and solution if not compatible (see below),
- the circumstances under which the product requires additional support / reinforcement for example when the substrate is coated with an unsuitable or unknown product where compatibility with the rendering, and hence the degree of adhesion (bond strength), cannot be established,
- details on the type / size of fixing required to reinforce or retain reinforcement to the substrate to be coated. The frequency, fixing pattern and method of installing the fixings (where required),
- the test methods to be used on site to determine adequacy of fixings and of primer coats,
- the test methods to be used on site to determine adhesion (bond strength) of the rendering together with the minimum values given in the ETA,
- the values required to be achieved for fixing strength and adhesion (bond strength) shall be 80 % of the values achieved in the approval tests,
- the specification for the reinforcement media (which may be fixed to the pre-installed fixings) for the particular scenario,
- the installation instructions for the location and retention of the reinforcement media (including its intended end position within the rendering thickness),
- the environmental conditions under which the rendering product may be mixed (as applicable) and applied,
- the instructions for mixing (as applicable) including product to water quantity ratios; the quality of water, e.g. 'potable'; any additives, their specification, ratio and conditions of use; the type of equipment required to effect correct mixing of the product and the mixing cycle time,
- the pressure settings and recommended spray tip sizes for correct application of the rendering using the specified type of equipment (where rendering is sprayed),
- if not sprayed, the method of application of the product,
- details of rendering thicknesses (with tolerances) required for different periods of fire resistance and substrate type and section size,
- instructions on overcoat times and restrictions (if any) on re-coating,
- guidance on trowelling, tamping or any other form of truing the surface of the rendering to produce a more regular finish than that achievable by initial application (if required),
- details of the maximum amount of cracking permitted expressed in the ETA as a maximum width of crack and total length of cracks per square metre of rendering,
- details on over-coating the rendering with either proprietary coatings of another manufacture or those made by the rendering ETA holder as part of the kit (if necessary) e.g. for better weather protection,
- guidance on masking work locations during the application of such products.

The mean density quoted in the ETA is that at which the approval tests were conducted and for which the performance characteristics are valid. A tolerance of $\pm 15\%$ on the quoted mean is accepted as the field of 'direct application' for which the quoted performance characteristics are deemed valid.

It is recognized that in practice it is difficult to control the density of the sprayed mix. However, the density of the sprayed rendering shall not fall outside the lower tolerance. If the density exceeds the upper tolerance it will be necessary to evaluate other parameters. This constitutes a field of extended application. Although performance characteristics are unlikely to be compromised at higher densities the effect of additional mass needs to be considered. Consequently, adhesion/bond strength (if the rendering is not reinforced or mechanically fixed), the thickness of the rendering and the substrate type, for example flat or with re-entrant angles, need to be examined in order to establish the acceptability or otherwise of the higher density. As a guide a density of the mean plus 20% might be acceptable except possibly at the upper limit of thickness (e.g. a high fire resistance period combined with a slender steel profile with high A/V), where the additional mass of the rendering may give rise for concern.

Similarly, if sprayed at thicknesses greater than those specified whilst not detracting from performance the additional mass shall be considered, particularly if combined with a higher density.

The installation information shall also clearly specify any limitations for the product's use such as the product's incompatibility with certain environments or fire protection scenarios.

If the product cannot withstand mechanical damage without additional cladding of a specified type, this shall be identified.

Recommendations shall be given on the sequencing of works such that rendering is not applied until adjacent works, which might cause damage to it, are completed.

A recommendation to provide ventilation around completed works to avoid biological attack such as mould growth shall be included.

If the works are, for example, likely to be subject to vibration, special provisions such as the use of keying or reinforcing mesh may need to be specified.

Where the product is not compatible with being used in conjunction with another fire protective products to effect a fire protected structure this shall be identified.

Information shall be included on how to deal with junctions between elements and between old and new areas of rendering.

Guidance shall be given on how to deal with over-spraying existing rendering (if that is a recommended practice).

9.1.5 Maintenance and repair

The ETA holder shall identify in the installation instructions for the application/installation of the rendering specific instructions relating to the maintenance and repair of the rendering.

This shall include routine inspections of the rendering to check for damage, cleaning, re-application of the top coat / sealing coat (as applicable).

The repair procedure shall identify the controls to be imposed on the repair activity relating to:

- preparation of the damaged rendering for repair including the removal of damaged material and "dressing" of the surrounding rendering to achieve a sound perimeter bond surface,
- cleaning of the substrate and remaining original rendering,
- instructions on the replacement of reinforcing media (as applicable),
- identifying whether a special repair rendering product is required or whether the original product can be used effectively,
- mixing (as applicable) of the repair material,
- application of the repair material,
- re-application of top coat / sealing coat (as applicable).

9.2 Additional information

The additional information is given in Part 1 "General", Chapter 9.

ANNEX A LIST OF REFERENCE DOCUMENTS

EN 312:2010	Particle Boards - Specification
EN 1015	Methods of test for mortar for masonry; Part 6: Determination of bulk density of fresh mortar Part 10: Determination of dry bulk density of hardened mortar Part 11: Determination of flexural and compressive strength of hardened mortar Part 12: Determination of adhesive strength of hardened rendering and plastering mortars on substrates
EN ISO 1182	Reaction to fire tests for building products - Non-combustibility test
EN 1323	Adhesives for tiles - Concrete slab for test
EN 1363-1	Fire resistance tests; Part 1: General requirements
EN ISO 1460	Metallic coatings - Hot dip galvanized coatings on ferrous materials - Gravimetric determination of the mass per unit area
EN ISO 1461	Hot dip galvanized coatings on fabricated iron and steel articles - Specifications and test methods
EN ISO 1716	Reaction to fire tests for building products - Determination of the heat of combustion
EN 1745:2002	Masonry and masonry products - Methods for determining design thermal values
EN ISO 2811	Paints and varnishes
EN ISO 3506-1	Mechanical properties of corrosion-resistant stainless-steel fasteners; Part 1: Bolts, screws and studs
EN ISO 4892-3:2006	Plastics - Methods of exposure to laboratory light sources; Part 3: Fluorescent UV lamps
EN 10025	Hot rolled products of non-alloy structural steels; Part 1: General delivery conditions Part 2: Technical delivery conditions for flat products
EN 10088:2005	Stainless steels; Part 2: Technical delivery conditions for sheet/plate and strip of corrosion resisting steels for general purposes Part 3: Technical delivery conditions for semi-finished products, bars, rods and sections and bright products of corrosion resisting steels for general purposes
EN 10326	Continuously hot-dip coated strip and sheet of structural steels – Technical delivery conditions
EN 10327	Continuously hot-dip coated strip and sheet of low carbon steels for cold forming – Technical delivery conditions
EN ISO 11925-2	Reaction to fire tests – Ignitability of building products subjected to direct impingement of flame; Part 2: Single-flame source test
EN 12086	Thermal insulating materials for building application - Determination of water vapour transmission properties
EN 12467:2006	Fibre-cement flat sheets – Product specification and test methods
EN 12524:2000	Building materials and products - Hygrothermal properties
EN ISO 12572	Hygrothermal performance of building materials and products - Determination of water vapour transmission properties
EN 12667	Thermal performance of building materials and products - Determination of thermal resistance by means of guarded hot plate and heat flow meter methods - Products of high and medium thermal resistance

EN 12939	Thermal performance of building materials and products - Determination of thermal resistance by means of guarded hot plate and heat flow meter methods - Thick products of high and medium thermal resistance
EN ISO 12944-6:1998	Paints and varnishes - Corrosion protection of structures by protective paint systems, Part 6: Laboratory performance test
EN 13162:2009	Thermal insulation products for buildings - Factory made mineral wool products - Specification
EN 13169:2008	Thermal insulation products for buildings - Factory made products of expanded perlite (EPB) - Specification
EN 13238:2010	Reaction to fire tests for building products - Conditioning procedures and general rules for selection of substrates
EN 13381	Test methods for determining the contribution to the fire resistance of structural members Part 1: Horizontal protective members Part 2: Vertical protective members Part 3: Applied protection to concrete members Part 4: Applied passive protection products to steel members Part 5: Applied protection to concrete/profiled sheet steel composite members Part 6: Applied protection to concrete filled hollow steel columns Part 7: Applied protection to timber members Part 8: Applied reactive protection to steel members
EN 13501	Fire classification of construction products and building elements; Part 1: Classification using test data from reaction to fire tests Part 2: Classification using data from fire resistance tests, excluding ventilation services Part 3: Classification using data from fire resistance tests systems and services
EN 13658-2	Metal lath and beads - Definitions, requirements and test methods; Part 2: External rendering
EN ISO 13788	Hygrothermal performance of building components and building elements - Internal surface temperature to avoid critical surface humidity and interstitial condensation - Calculation methods
EN 13823	Reaction to fire tests for building products - Building products excluding floorings exposed to the thermal attack by a single burning item
EN ISO 17050	Conformity assessment - Supplier's declaration; Part 1: General requirements Part 2: Supporting documentation
ISO 898-1	Mechanical properties of fasteners made of carbon steel and alloy steel; Part 1: Bolts, screws and studs
ISO 3233	Paints and varnishes - Determination of percentage volume of non-volatile matter by measuring the density of a dried coating
ISO 7724:1984	Paints and varnishes – Colourimetry Part 1: Principles Part 2: Colour measurement
ISO 7892	Vertical building elements - Impact resistance tests - Impact bodies and general test procedures
ISO 10456:2010	Building materials and products - Hygrothermal properties - Tabulated design values and procedures for determining declared and design thermal values
Guidance Paper K:	The Attestation of Conformity Systems and the Role and Tasks of the Notified Bodies in the Field of the CPD, December 2004
ETAG 004; vers March 2000	ETA-Guideline for external thermal insulation composite systems with rendering
EOTA TR 001: vers February 2003	Determination of impact resistance of panels and panel assemblies

EOTA TR 034	General ER3 Checklist for ETAG/CUAP/ETA – Content and/or release of dangerous substances in products/kits;
EGOLF EA 5	Fire Testing; Method for the measurement of bonding properties of fire protection materials applied to steel, concrete and steel/concrete composite structures
ASTM E 736	Standard Test Method for Cohesion/Adhesion of Sprayed Fire-Resistive Materials Applied to Structural Members

ANNEX B REACTION TO FIRE TESTS FOR BUILDING PRODUCTS – MOUNTING AND FIXING ARRANGEMENTS FOR RENDERINGS

B.1 Testing according to EN 13823 (SBI)

- Rendering and rendering kits intended for fire resisting applications shall be tested when applied in a laminar fashion to the substrate. The test shall be configured as the product will be used in practice e.g. with reinforcing fabric enclosed in the rendering and with any surface coating.
- Specimens for each wing are to be produced separately. Specimens shall be prepared according to clause 5.0.2 and conditioned according to clause 5.0.4. Assembly of both wings shall be performed on the sample trolley of the SBI testing device.
- A standard substrate according to EN 13238:2010 shall be used, which is to be set up at a distance of ≥ 80 mm to the backing board. The result applies to all substrates used in practice which are represented in this standard. If a non-standard substrate is used for testing the result applies only to that substrate.
- On substrates of classes A1 or A2 the renderings and rendering kits shall be tested with the maximum applied dry thickness. The result applies to all application thicknesses up to the thickness tested.
- For substrates of classes B, C, D, or E the renderings and rendering kits shall be tested with the maximum and minimum applied dry thickness. Three specimens shall be tested at each thickness. The result¹⁴ applies to all thicknesses between and including the thicknesses tested.
- If the renderings and rendering kits have surface coatings, the test shall be carried out with that coating which from experience based on formulation, existing experience or testing could cause the worst result.

In case of combustible substrates (i.e. those classified as other than A1) the joint between the wings shall be protected by A1 classified mineral wool or similar material to prevent a contribution to the energy release from the substrate that would never happen in practice (see Figure B.1).

- Wire mesh may need to be fixed to the substrate to ensure that the rendering adheres to the wings.

B.2 Testing according to EN ISO 11925-2 (small burner test)

- If used, the production of the test specimens and execution of the test shall be carried out in accordance with the requirements of EN ISO 11925-2.

B.3 Testing according to EN ISO 1716 and EN ISO 1182

- The production of test specimens and execution of the tests shall be carried out in accordance with the requirements of EN ISO 1716 and EN ISO 1182.
- The tests shall be carried out with that coating which from experience based on formulation, existing experience or testing could cause the worst result.

¹⁴ If the test results lead to two different classifications, the worst result will be considered or further tests could be carried out if requested by the ETA -Applicant.

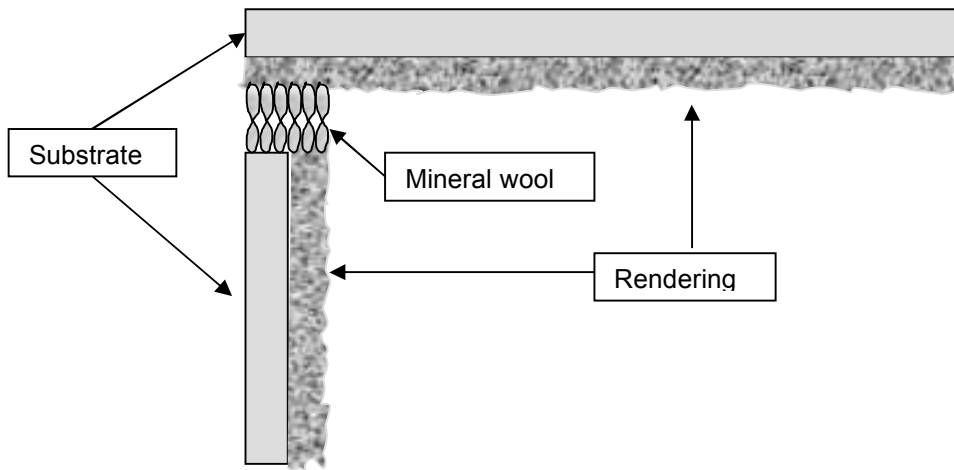

Figure B.1
Configuration of the vertical joint for testing a rendering system

ANNEX C TEST METHOD FOR EVALUATING CORROSION OF STEEL SUBSTRATES INDUCED BY THE RENDERING

C.1 Scope

This test method covers a procedure for measuring corrosion to steel induced by renderings.

C.2 Summary of test method

In this test method panels of bare, primed and galvanized steel are sprayed with rendering and subjected to room temperature and humidity conditions for 240 h in a temperature and humidity controlled chamber. Corrosion is determined by the loss of mass of the sheets.

Only steel with the finishes claimed by the ETA holder to be suitable for use with the rendering are required to be tested.

C.3 Significance and use

It is the intent of this test method to determine the relative corrosive properties of renderings to provide an indication of serviceability. Satisfactory performance of a rendering applied to structural members and assemblies depends upon its ability to withstand the various influences that occur during the life of the structure, as well as upon its satisfactory performance under fire conditions.

This test method evaluates the relative corrosion of steel induced by rendering and determines whether the presence of rendering increases or has no effect on the corrosion characteristics of steel.

C.4 Apparatus

- Standard Temperature Humidity Cabinet, equipped to maintain a temperature of $(35 \pm 2)^\circ\text{C}$ and $(95 \pm 5)\%$ relative humidity. The cabinet and all accessories shall be of a material that does not affect the corrosiveness of the atmosphere in the cabinet. Additionally, all parts that come into contact with the test samples shall be made of a material that does not cause electrolytic corrosion. Adequate circulation of the atmosphere over the samples shall be provided.
- Weighing Scales, having a capacity of 5 kg and a sensitivity of $\pm 0,1$ g.
- Wire Brush, with brass wire bristles approximately 25 mm long mounted in a handle. The bristle section shall be 127 mm long by 19 mm wide.

C.5 Materials

This test method requires the application of rendering in accordance with the ETA-Applicant's instructions. The apparatus, materials, and procedures used to apply the rendering shall be representative of application for the fire test and in practice.

The density of the prepared sample shall be the same as the density fire tested within $\pm 15\%$ of the declared tolerance.

Steel sheets shall be 200 mm \times 200 mm \times 5 mm and shall be:

bare steel	to EN 10025 grade S, except S185
primed	to EN 10025 grade S, except S185, steel coated with iron oxide alkyd primer, or other specified by the ETA-Applicant
galvanized steel	to EN 10025 grade S, except S185 galvanised in accordance with EN 10326

C.6 Laboratory test samples

There shall be four steel sheets of each type to be evaluated, e.g. bare, primed, galvanised steel.

The sheets in each set shall be designated a, b, c and d.

The steel sheets shall be free of all surface rust.

C.7 Procedure

Wash the steel sheets with alcohol or acetone to remove any oil or grease. Dry at room temperature.

Weigh each sheet to the nearest 0,1 g and record its mass.

Protect the edges of the sheets and apply a suitable coating to one face. This coating shall be stable under the conditions of this test method and shall not promote corrosion; paraffin wax is suggested.

Apply the rendering at a minimum thickness for which the ETA-Applicant has a fire resisting classification.

Determine the density and thickness of each laboratory prepared sample.

Samples a and b of each set:

- Condition the samples for (240 ± 2) h at room temperature (23 ± 2) °C and relative humidity not greater than 60%.
- Remove the rendering, as well as the protective wax coating, from the steel sheets.
- Remove all surface rust from the sheets with the wire brush described in clause C.4 and clean with solvent (alcohol or acetone).
- Weigh the sheets to the nearest 0,1 g, and record their mass.

Samples c and d of each set:

- Place the sheets into the temperature humidity cabinet and keep at (35 ± 2) °C and (95 ± 5) % relative humidity for a duration of (240 ± 2) h.
- At the completion of the 240 h period, remove the samples from the cabinet.
- Remove the rendering and the protective wax coating, from the sheets.
- Remove all surface rust from the sheets with the wire brush described in clause C.4 and clean with solvent (alcohol or acetone).
- Weigh the sheets to the nearest 0,1 g, and record its mass.

C.8 Calculation

Calculate the mean loss of mass at the end of the initial ageing period of samples a and b and the loss of mass at the end of the 240 h humidity test of samples c and d as follows:

For each sample: $\text{loss of mass (g/mm}^2\text{)} = \frac{\text{mass before (g)} - \text{mass after (g)}}{\text{Area of sheet (mm}^2\text{)}}$

Calculate the mean loss of mass at the end of the initial ageing period (a and b), and the mean loss of mass at the end of the 240 h humidity test (c and d) as follows:

$$\text{mean loss of mass}_1 = \frac{\text{loss of mass of sample a} + \text{loss of mass of sample b}}{2}$$

$$\text{mean loss of mass}_2 = \frac{\text{loss of mass of sample c} + \text{loss mass of sample d}}{2}$$

C.9 Report

Report the thickness of the rendering in millimetres, the density of the rendering in kg/m³ and the individual and mean loss of mass in g/mm² of each sample and set.

Report all information on the steel including the grade; the nature of the primer, including the product name and manufacturer, the measured dry film thickness and the elapsed time (number of days or hours) between application of primer and application of rendering.

ANNEX D TEST METHOD FOR AIR EROSION OF RENDERINGS

D.1 Scope

This test method covers a procedure for determining the effect of an air stream upon renderings.

D.2 Terminology

Definitions:

denier, n:	the number of grams per 9 000 m.
end (fabric), n:	an individual warp yarn (single or ply) cord.
pick, n:	an individual filling yarn.
air erosion:	the action or process of being eroded by an air stream.

D.3 Summary of test method

This test method covers a procedure for determining the effect of an air stream upon renderings in plenums. The rendering is subjected to a tangential air stream for a minimum of 24 h. Collection filters downstream from the sample are weighed at frequent intervals to determine the amount of material removed from the sample.

D.4 Significance and use

It is the intent of this test method to determine properties of renderings that may be used to provide an indication of serviceability. Satisfactory performance of a rendering depends upon its ability to withstand the various influences that may occur during construction and during the life of the system, as well as upon its performance under fire conditions.

Air erosion tests on renderings are conducted to evaluate the behaviour of the rendering when subjected to plenum air streams during normal service conditions. Such tests evaluate the resistance to dusting, flaking, spalling, and delamination of the rendering.

D.5 Apparatus

- Duct System, made of galvanized steel, horizontally positioned, with one rectangular opening of minimum size 0,36 m² in the centre of the top of the duct and 50 mm from each vertical side.
- Pitot Tube, used in conjunction with a suitable manometer to measure air velocities in the duct.
- Blower, capable of moving air at a temperature of (20 ± 10) °C and (50 ± 20) % RH through the entire cross section of the duct at a velocity sufficient to handle the test requirement.
- Filters, upstream from the test sample (at the blower end) and located downstream of the test sample. These filters shall be made of 30-denier nylon. The nominal construction of the fabric shall be 37 ends per 10 mm and 32 picks per 10 mm, or finer.
- Scale, having a capacity of 100 g and a sensitivity of ± 0,001 g.

D.6 Materials

This test method requires the application of rendering in accordance with the ETA-Applicant's normal method and representative of application on site.

The density of the prepared sample shall be similar to that of the fire tested sample(s)¹⁵.

D.7 Test sample

The test sample shall consist of rendering applied to the substrate. A separate test shall be conducted for each substrate intended to be used.

The substrate shall be of minimum area 0,36 m² with the rendering being applied at the thickness recommended by the ETA-Applicant.

Prepare duplicate samples and allow to dry and harden at a temperature of (20 ± 10) °C and an RH not

¹⁵ Tolerances of density as indicated in clause 5.0.2.

greater than 60 % until successive mass reading, taken at 24 h intervals, differ by less than 1%.

D.8 Procedure

Test one sample to determine thickness and density.

Dry the collecting filter at (50 ± 2) °C for 1 h, weigh and place in the apparatus.

Place the second sample into the duct opening so that the face of the sample and the inside face of the duct are positioned flush and in the same plane. All edges shall extend at least 50 mm beyond the duct opening.

Place the pitot tube (100 ± 2) mm from the upstream edge of the sample at the centreline of the duct and 50 mm below the top side of the duct.

With both filters and the sample in position, maintain the blower at the velocity of $(6 \pm 0,25)$ m/s.

At elapsed times of 1 h, 6 h and 24 h, stop the blower and carefully remove, fold, dry at (50 ± 2) °C and then reweigh the collecting filter. If the collecting filter continues to show a mass gain at 24 h, continue the test, making measurements every 24 h until a constant mass is reached.

D.9 Report

Report the mass of the collecting filter in grams before and after each test interval. After each interval, record the net mass gain both individually and cumulatively. Also report the total net mass gain.

Report the thickness in mm and the density in kg/m^3 of the sample.

Indicate the techniques such as tamping, trowelling, surface sealing, or similar finishing operations and the extent that they are made.

The report of the data and of the test results shall be in accordance with Guidance Paper K.

ANNEX E DURABILITY TESTING OF RENDERINGS

E.1 Introduction

The durability of renderings is based on comparative data between samples subjected to artificial exposure conditions and control samples.

The parameters used are:

- adhesion (bond strength),
- insulation efficiency,
- visual observations.

NOTE 12: In the following tests adhesion (bond strength) is used as a characteristic to determine changes before and after the test. Adhesion (bond strength) is, therefore, required to be measured in these tests even though in practice reinforcement or mechanical fixings may be used.

NOTE 13: The insulation efficiency test is conducted only on a steel substrate since the durability characteristics of the rendering are considered to be independent of the substrate. Adhesion (bond strength) and visual observations are relevant to all substrates.

E.2 Specimens

The substrate specifications are given in clause 5.0.2.

If the rendering system requires the steel to be primed, the steel shall be primed.

If the rendering is able to be used without a top coat it shall be tested without a top coat.

The rendering shall be applied at a nominal thickness of 25 mm or at the minimum thickness if greater than 25 mm or the maximum thickness if less than 25 mm. The rendering thickness shall be measured and recorded at ≥ 10 uniformly distributed points prior to testing.

The edges of the specimens shall be sealed in order to prevent the joint between rendering and substrate being subjected to the exposure conditions.

For panels, used for durability testing, a protective coating (primer) shall be applied to the back and edges (including all control panels), to prevent rust contamination of the cabinet.

For each exposure condition to be tested, four specimens shall be prepared: two for adhesion testing and two for insulation efficiency. In addition, four specimens shall be prepared as controls: two to establish values for adhesion (bond strength) and two to establish insulation efficiency.

The specimens shall be prepared and conditioned in accordance with clauses 5.0.2 and 5.0.3 and with the ETA-Applicant's instructions for the rendering system. Control specimens shall then be stored under conditions and for a period of time as specified by the ETA-Applicant. After exposure to the specified durability tests the specimens shall be stored in the conditions specified in clause 5.0.3 until constant mass is attained before either the adhesion (bond strength) or insulation efficiency test is conducted.

It is recommended that photographs be taken before and after the durability tests.

E.3 UV exposure

Two specimens shall be tested in accordance with EN ISO 4892-3:2006 for 112 cycles (equivalent to 28 days).

Exposure mode 2 with combined lamps shall be used.

E.4 Heat – rain

Four specimens to the specification in annex E.2 shall be subjected to the exposure conditions specified in EN 12467:2006, clause 7.4.2 for 50 cycles.

E.5 High humidity

Four specimens to the specification in annex E.2 shall be exposed for four weeks to (35 ± 2) °C and (95 ± 5) % relative humidity.

E.6 Heat – cold

Four specimens to the specification in annex E.2 shall be subjected to the following exposure conditions,

which shall be repeated five times. The test shall be conducted at ambient humidity.

Period/duration (hours)	Temperature
2	1 st cycle - increase from ambient temperature to $(60 \pm 2) ^\circ\text{C}$ Subsequent cycles – increase from $(-15 \pm 2) ^\circ\text{C}$ to $(60 \pm 2) ^\circ\text{C}$
4	Hold at $(60 \pm 2) ^\circ\text{C}$
2	Decrease from $(60 \pm 2) ^\circ\text{C}$ to $(-15 \pm 2) ^\circ\text{C}$
16	Hold at $(-15 \pm 2) ^\circ\text{C}$

If higher maximum temperatures or lower minimum temperatures are expected the expected maximum/minimum temperature shall be tested.

E.7 Freeze-thaw

- a) For use category type X: Four specimens to the specification in annex E.2 shall be subjected to the following exposure conditions, which shall be repeated twenty five times. The test shall be conducted at ambient humidity.

Period/duration (hours)	Condition, temperature and water immersion
4	Immersion in water at $(23 \pm 2) ^\circ\text{C}$
2	Remove from water, reduce temperature to $(-5 \pm 2) ^\circ\text{C}$ over 2 h
16	Hold at $(-5 \pm 2) ^\circ\text{C}$ (out of water)
2	Increase temperature from $(-5 \pm 2) ^\circ\text{C}$ to $(23 \pm 2) ^\circ\text{C}$ (out of water)

- b) For use category type Y: Four specimens to the specification in annex E.2 shall be subjected to the following exposure conditions, which shall be repeated twenty-five¹⁶ times.

Period/duration (hours)	Temperature	Relative humidity
4	$(23 \pm 2) ^\circ\text{C}$	$95 \pm 5 \%$
2	Reduce from $(23 \pm 2) ^\circ\text{C}$ to $(-10 \pm 2) ^\circ\text{C}$	n/a
16	Hold at $(-10 \pm 2) ^\circ\text{C}$	n/a
2	Increase from $(-10 \pm 2) ^\circ\text{C}$ to $(23 \pm 2) ^\circ\text{C}$	$95 \pm 5 \%$

E.8 Adhesion (bond strength) – Test procedure

Two control specimens (unexposed specimens) as specified in annex E.2 and two specimens after being exposed to the testing regimes in the annexes E.3 to E.7 (as appropriate) shall be tested in accordance with method EGOLF EA 5. Four tensile bond tests shall be conducted on each panel (e.g. four on each

¹⁶ Experience may enable the relatively high number of cycles to be reduced, in which case this will be covered in a future Progress File.

panel). For each pair of specimens the highest and lowest values shall be discarded and the remaining six averaged, as specified in EGOLF EA 5.

- Test results

The mean value of the tensile bond after durability testing shall be not less than 80 % of the control value. If the test has been performed for steel bars, galvanized substrates etc., the results are also valid for steel and concrete slabs.

E.9 Insulation efficiency – Test procedure

E.9.1 General

The small scale furnace fire test shall be carried out under the condition of the standard time – temperature curve as defined in EN 1363-1.

The specimens shall be prepared, conditioned and measured as specified in clause 5.0.4.

After exposure to environment conditions, if any, the specimens shall again be stored in the conditions specified in clause 5.0.4 for a minimum of one week before fire testing.

E.9.2 Specimens

Two control specimens (unexposed specimens) as specified in annex E.2 and two specimens after being exposed to the testing regimes in the annexes E.4 to E.7 (as appropriate) are required to be tested.

E.9.3 Test procedure

The specimens may be tested individually or in one test. The specimen(s) shall be placed in the furnace in a vertical or in a horizontal position such that the side with the rendering system is exposed to the fire. The specimen(s) shall be mounted in a frame which forms part of one side (wall or ceiling) of the furnace. The non-fire side shall be covered using vermiculite or calcium silicate board with a minimum thickness of 5 mm with a bulk density of $(475 \pm 25) \text{ kg/m}^3$ or mineral wool (stone wool) with a bulk density of $(110/120 \pm 10) \text{ kg/m}^3$ ¹⁷.

Two thermocouples shall be attached to the non-fire side of the steel panels. These thermocouples shall be located close to the centre 20 mm apart. The thermocouples shall be of the K type according to EN 1363-1 but without a copper disc and without insulation pad. The thermocouples shall be fixed to the back of the steel panels by welding (resistance spot welding).

The time for the non-fire side of the steel to reach a mean temperature of 500 °C shall be recorded.

E.9.4 Test results

The time for the non-fire side of the steel to reach a mean temperature of 500 °C shall be recorded. For information purposes furthermore, observation shall be made of the rendering, noting any detachment, delamination or cracking and be reported. The mean time for the non-fire side of the steel of the specimens exposed to the durability tests shall be not less than 85 % of the time for the non-fire side of the steel of the control specimens to reach a mean of 500 °C. No single result shall be less than 80 % of the mean time to 500 °C of the initial test.

Where the result falls outside these criteria, four additional specimens may be exposed, tested and assessed. All four specimens shall fulfil the pass criteria.

E.9.5 Interpretation of test results

When evaluating primers/primer families:

- if the result is better than or equal to that of the reference primer, the primer is considered acceptable,
- if the result obtained with an alternative primer is worse, the same criteria to assess durability samples shall be applied.

¹⁷ As the Insulating Efficiency Test is an indirect testing for comparison (durability, different primers, different top coats) all tests of one assessment shall be carried out under identical conditions/parameters.

E.10 Visual observations

The condition of all specimens after testing shall be visually inspected and changes from the pre-test condition shall be recorded. This shall include a record of all cracking and fissuring including the size and depth of such cracks and fissures. This shall be expressed in the ETA as maximum width of crack and total length of cracks per square metre of rendering.

ANNEX F DETERMINATION OF THE DECLARED THERMAL CONDUCTIVITY AND THE CONVERSION FACTOR TO HIGH MOISTURE CONTENT (FOR MINERAL WOOL BASED RENDERINGS)

F.1 Determination of the \bar{u} fractile value at 10 °C, at dry conditions ($\bar{u}_{10,dry,90/90}$)

F.1.1 Measurement of the \bar{u}_{dry} at 10 °C

F.1.1.1

Test specimens for the determination of the thermal conductivity λ at 10 °C shall be conditioned in accordance with clause 5.0.4.

F.1.1.2

The thermal conductivity of the test specimens conditioned according to F.1.1.1 shall be measured according to EN 12667 or EN 12939 for thick products at a mean temperature of $(10 \pm 0,3)$ °C.

During the measurement, precaution shall be taken to avoid moisture absorption by the specimen. It is acceptable, for instance, to put the test specimen into a thin plastic bag.

F.1.2 Calculation of the \bar{u} fractile value at 10 °C, at dry conditions ($\bar{u}_{10,dry,90/90}$)

F.1.2.1

The λ fractile at 10 °C, at dry conditions ($\lambda_{10,dry,90/90}$) as a limit value representing at least 90 % of the production with a confidence limit of 90 % shall be calculated using the procedures as detailed in EN 13162:2009 Annex A. It shall be noted that the λ_D shall be calculated in accordance with clause F.3.

F.2 Determination of the moisture conversion factor ($f_{u,1}$)

For the determination of the moisture conversion factor $f_{u,1}$, two sets of measurements are needed.

Set 1

Two measurements on dry test specimens, to determine $\lambda_{10,dry}$ and u_{dry} (moisture content mass by mass).

Set 2

Two measurements on test specimens conditioned at (23 ± 2) °C and (50 ± 5) % relative humidity, to determine $\lambda_{10,(23,50)}$ and $u_{23,50}$ (moisture content mass by mass).

F.2.1 Procedure

F.2.1.1 Set 1

Dry the two test specimens following the procedure in F.1.1.1.

Determine for each test specimen the mass in dry condition. Take the mean of the two values to determine the m_{dry} . The u_{dry} , being the moisture content in dry condition, is by definition set to 0.

Determine for each test specimen the λ value at 10 °C following the procedure in F.1.1.2. Take the mean of the two values to determine the $\lambda_{10,dry}$.

F.2.1.2 Set 2

F.2.1.2.1

Condition the two test specimens at (23 ± 2) °C and (50 ± 5) % relative humidity following the procedures detailed in EN 13169:2008, 5.2, step 2.

F.2.1.2.2

Determine for each test specimen the mass at (23 ± 2) °C and (50 ± 5) % relative humidity.

Take the mean of the two values to determine the mass at 23 °C and 50 % relative humidity as $m_{23,50}$.

F.2.1.2.3

Calculate $u_{23,50}$ by the following formula:

$$u_{23,50} = \frac{m_{23,50} - m_{\text{dry}}}{m_{\text{dry}}}$$

where

$m_{23,50}$ is the mass at 23 °C and 50 % relative humidity according to F.2.1.2.2,

m_{dry} is the mass according to F.2.1.1.

F.2.1.2.4

Determine for each test specimen conditioned according to F.2.1.2.1 the λ value in accordance with EN 12667 or EN 12939 for thick products at a mean temperature of $(10 \pm 0,3)$ °C.

Take the mean of the two values to determine $\lambda_{10,(23,50)}$.

F.2.1.3 Calculation of the moisture conversion factor ($f_{u,1}$)

The moisture conversion factor $f_{u,1}$ shall be calculated by the following formula (derived from ISO 10456:2010, formula 4):

$$f_{u,1} = \frac{\ln \frac{\lambda_{10,(23,50)}}{\lambda_{10,\text{dry}}}}{u_{23,50} - u_{\text{dry}}}$$

where

$\lambda_{10,(23,50)}$ is determined according to F.2.1.2.4,

$\lambda_{10,\text{dry}}$ is determined according to F.2.1.1,

$u_{23,50}$ is determined according to F.2.1.2.3,

u_{dry} is determined according to F.2.1.1 and is defined to be 0.

F.3 Calculation of the declared thermal conductivity \tilde{u}_D

The declared thermal conductivity λ_D shall be calculated using the following formula:

$$\lambda_{(23,50)} = \lambda_{10,\text{dry},90/90} * e^{f_{u,1}(u_{23,50} - u_{\text{dry}})}$$

where

$\lambda_{10,\text{dry},90/90}$ is determined according to F.1.2,

$f_{u,1}$ is determined according to F.2.1.3,

$u_{23,50}$ is determined according to F.2.1.2.3,

u_{dry} is determined according to F.2.1.1 and is defined to be 0.

The calculated value $\lambda_{(23/50)}$ shall be rounded upwards to the nearest 0,001 W/(m.K) and declared as $\lambda_{D(23,50)}$.

F.4 Determination of the conversion factor ($f_{u,2}$) to high moisture content

For the determination of the conversion factor to high moisture content $f_{u,2}$, two sets of measurements are needed.

Set 1

Two measurements on test specimens conditioned at (23 ± 2) °C and (50 ± 5) % relative humidity, to determine $\lambda_{10,(23,50)}$ and $u_{23,50}$ (moisture content mass by mass).

Set 2

Two measurements on test specimens conditioned at $(23 \pm 2) ^\circ\text{C}$ and $(80 \pm 5) \%$ relative humidity, to determine $\lambda_{10,(23,80)}$ and $u_{23,80}$ (moisture content mass by mass).

F.4.1 Procedure

F.4.1.1 Set 1

Determine the $\lambda_{10,(23,50)}$ and $u_{23,50}$ in accordance with F.2.1.2.

F.4.1.2 Set 2

F.4.1.2.1

Condition the two test specimens at $(23 \pm 2) ^\circ\text{C}$ and $(80 \pm 5) \%$ relative humidity following the procedures detailed in EN 13169:2008, clause 5.2, step 2.

F.4.1.2.2

Determine for each test specimen the mass at $(23 \pm 2) ^\circ\text{C}$ and $(80 \pm 5) \%$ relative humidity.

Take the mean of the two values to determine the mass at $23 ^\circ\text{C}$ and 80% relative humidity as $m_{23,80}$.

F.4.1.2.3

Calculate $u_{23,80}$ by the following formula:

$$u_{23,80} = \frac{m_{23,80} - m_{\text{dry}}}{m_{\text{dry}}}$$

where,

$m_{23,80}$ is the mass at $23 ^\circ\text{C}$ and 80% relative humidity according to F.4.1.2.2,

m_{dry} is the mass according to F.2.1.1.

F.4.1.2.4

Determine for each test specimen conditioned according F.4.1.2.1 the λ value in accordance with EN 12667 or EN 12939 for thick products at a mean temperature of $(10 \pm 0,3) ^\circ\text{C}$.

Take the mean of the two values to determine $\lambda_{10,(23,80)}$.

F.4.1.3 Calculation of the conversion factor to high moisture content ($f_{u,2}$)

The conversion factor to high moisture content $f_{u,2}$ shall be calculated by the following formula (derived from ISO 10456:2010, formula 4):

$$f_{u,2} = \frac{\ln \frac{\lambda_{10,(23,80)}}{\lambda_{10,(23,50)}}}{u_{23,80} - u_{23,50}}$$

where

$\lambda_{10,(23,80)}$ is determined according to F.4.1.2.4,

$\lambda_{10,(23,50)}$ is determined according to F.2.1.2,

$u_{23,80}$ is determined according to F.4.1.2.3,

$u_{23,50}$ is determined according to F.2.1.2.

For the determination of the moisture conversion factor $f_{u,1}$ and the conversion factor to high moisture content $f_{u,2}$, the test specimens shall be taken from the same production run.

NOTE 14: Thermal conductivity may also be measured at mean temperatures other than $10 ^\circ\text{C}$, providing that the accuracy of the relationship between the temperature and thermal properties is well documented.