

European Organisation for Technical Approvals
Europäische Organisation für Technische Zulassungen
Organisation Européenne pour l'Agrément Technique

red. Anm.: Diese Bekanntmachung ist derzeit nur in der englischen Fassung verfügbar

ETAG No 018

version December 2011

GUIDELINE FOR EUROPEAN TECHNICAL APPROVAL
OF

FIRE PROTECTIVE PRODUCTS

PART 4: FIRE PROTECTIVE BOARD, SLAB AND
MAT PRODUCTS AND KITS

EOTA
Kunstlaan 40 Avenue des Arts, B - 1040 Brussels

TABLE OF CONTENTS

FOREWORD	6
Background.....	6
List of reference documents	6
SECTION ONE: INTRODUCTION	7
1. PRELIMINARIES.....	7
1.1 Legal basis.....	7
1.2 Status of ETA-Guidelines	7
2. SCOPE	7
2.1 Scope.....	7
2.2 Use categories, products families, kits and systems	7
2.2.1 General.....	7
2.2.2 Use category related to weather exposure	8
2.2.3 Use category related to intended use	8
2.3 Assumptions	10
2.4 Use of this ETA-Guideline	10
3 TERMINOLOGY	10
3.1 Common terminology and abbreviations	11
3.2 Particular terminology and abbreviations	11
SECTION TWO: GUIDANCE FOR THE ASSESSMENT OF THE FITNESS FOR USE.....	12
4. REQUIREMENTS.....	12
4.0 General	12
4.1 ER 1: Mechanical resistance and stability	12
4.2 ER 2: Safety in case of fire.....	12
4.3 ER 3: Hygiene, health and the environment.....	12
4.4 ER 4: Safety in use	12
4.4.1 Mechanical resistance and stability (of fixing systems)	12
4.4.2 Resistance to impact / movement	12
4.4.3 Adhesion	12
4.5 ER 5: Protection against noise	13
4.6 ER 6: Energy economy and heat retention.....	13
4.7 Related aspects of durability, serviceability and identification	13
5. SPECIFIC METHODS OF VERIFICATION.....	13
5.0 General	13
5.1 Verification methods for kits.....	14
5.1.1 ER 1: Mechanical resistance and stability	14
5.1.2 ER 2: Safety in case of fire.....	14
5.1.3 ER 3: Hygiene, health and the environment	14
5.1.4 ER 4: Safety in use.....	15
5.1.5 ER 5: Protection against noise.....	19
5.1.6 ER 6: Energy economy and heat retention	19
5.1.7 Related aspects of durability, serviceability and identification	19
5.2 Verification methods for boards, slabs and mats	19
5.2.0 General.....	19
5.2.2 ER 2: Safety in case of fire.....	20
5.2.3 ER 3: Hygiene, health and the environment	21
5.2.4 ER 4: Safety in use.....	21
5.2.6 ER 6: Energy economy and heat retention	21
5.2.7 Related aspects of durability, serviceability and identification	21
5.3 Verification methods for Components: Mechanical fasteners	24
5.3.0 General.....	24
5.3.2 ER 2: Safety in case of fire.....	24
5.3.3 ER 3: Hygiene, health and the environment	24
5.3.4 ER 4: Safety in use.....	25

5.3.7	Related aspects of durability, serviceability and identification	26
5.4	Verification methods for Components: Adhesives	27
5.4.0	General.....	27
5.4.2	ER 2: Safety in case of fire.....	27
5.4.3	ER 3: Hygiene, health and the environment	27
5.4.4	ER 4: Safety in use.....	27
5.4.7	Related aspects of durability, serviceability and identification	28
5.5	Verification methods for Components: Jointing materials	28
5.5.0	General.....	28
5.5.2	ER 2: Safety in case of fire.....	28
5.5.3	ER 3: Hygiene, health and the environment	29
5.5.7	Related aspects of durability, serviceability and identification	29
5.6	Verification methods for Components: Insulation products	30
5.6.0	General.....	30
5.6.2	ER 2: Safety in case of fire.....	30
5.6.3	ER 3: Hygiene, health and the environment	30
5.6.6	ER 6: Energy economy and heat retention	31
5.6.7	Related aspects of durability, serviceability and identification	31
5.7	Verification methods for Components: Profiles, framework, studs, etc.	32
5.7.0	General.....	32
5.7.2	ER2: Safety in case of fire.....	32
5.7.3	ER3: Hygiene, health and the environment	32
5.7.4	ER4: Safety in use.....	32
5.7.6	ER6: Energy economy and heat retention.....	33
5.7.7	Aspects of durability, serviceability and identification	33
6.	ASSESSING AND JUDGING THE FITNESS OF KITS AND COMPONENTS FOR INTENDED USE	34
6.0	General	34
6.1	Assessment and judging for kits	34
6.1.0	General.....	34
6.1.1	ER 1: Mechanical resistance and stability	34
6.1.2	ER 2: Safety in case of fire.....	34
6.1.3	ER 3: Hygiene, health and the environment	35
6.1.4	ER 4: Safety in use.....	35
6.1.5	ER 5: Protection against noise.....	36
6.1.6	ER 6: Energy economy and heat retention	36
6.1.7	Related aspects of durability, serviceability and identification	36
6.2	Assessment and judging for boards, slabs and mats	36
6.2.0	General.....	36
6.2.2	ER 2: Safety in case of fire.....	36
6.2.3	ER 3: Hygiene, health and the environment	36
6.2.4	ER 4: Safety in use.....	37
6.2.6	ER 6: Energy economy and heat retention	37
6.2.7	Related aspects of durability, serviceability and identification	37
6.3	Assessment and judging for Components: Mechanical fasteners	39
6.3.0	General.....	39
6.3.2	ER 2: Safety in case of fire.....	39
6.3.3	ER 3: Hygiene, health and the environment	39
6.3.4	ER 4: Safety in use.....	39
6.3.7	Related aspects of durability, serviceability and identification	40
6.4	Assessment and judging for Components: adhesives	40
6.4.0	General.....	40
6.4.2	ER 2: Safety in case of fire.....	41
6.4.3	ER 3: Hygiene, health and the environment	41
6.4.4	ER 4: Safety in use.....	41
6.4.7	Related aspects of durability, serviceability and identification	41
6.5	Assessment and judging for Components: Jointing materials	41
6.5.0	General.....	41

6.5.2	ER 2: Safety in case of fire.....	41
6.5.3	ER 3: Hygiene, health and the environment	41
6.5.7	Related aspects of durability, serviceability and identification	42
6.6	Assessment and judging for Components: insulation products	43
6.6.0	General.....	43
6.6.2	ER 2: Safety in case of fire.....	43
6.6.3	ER 3: Hygiene, health and the environment	43
6.6.6	ER 6: Energy economy and heat retention	43
6.6.7	Related aspects of durability, serviceability and identification	43
6.7	Assessment and judging for Components: Profiles, framework, studs, etc.	44
6.7.0	General.....	44
6.7.2	ER2: Safety in case of fire.....	44
6.7.3	ER3: Hygiene, health and the environment	44
6.7.4	ER4: Safety in use.....	44
6.7.6	ER6: Energy economy and heat retention.....	45
6.7.7	Aspects of durability, serviceability and identification	45
7.	ASSUMPTIONS AND RECOMMENDATIONS UNDER WHICH THE FITNESS FOR USE OF THE PRODUCTS IS ASSESSED.....	45
7.0	General	45
7.1	Design of works	45
7.2	Packaging, transport and storage	45
7.3	Execution of works.....	45
7.4	Maintenance and repair	45
	SECTION THREE: ATTESTATION OF CONFORMITY	46
8.	ATTESTATION OF CONFORMITY	46
8.1	EC-decision.....	46
8.2	Responsibilities	46
8.2.0	Introduction.....	46
8.2.1	Tasks for the manufacturer	46
8.2.2	Tasks for the manufacturer or the approved body	46
8.2.3	Tasks for the approved body.....	46
8.3	Documentation	46
8.4	CE-marking and information	48
8.4.1	Introduction.....	48
8.4.2	Example	48
	SECTION FOUR.....	50
9.	THE ETA CONTENT	50
9.1	The ETA-content.....	50
9.2	Additional information	50
9.3	Exceptions	50
	ANNEX A: List of reference documents	51
	ANNEX B: EN 13823: Reaction to fire tests for building products - Building products excluding floorings exposed to the thermal attack by a single burning item Mounting and fixing provisions	55
B.1	Terminology	55
B.2	Mounting & Fixing in accordance with EN 13823	55
B.2.1	Dimensions of the test rig.....	55
B.2.2	Test specimen	55
B.2.3	Mounting and fixing of the test assembly	55
B.3	Figures	56
	ANNEX C: Assessment for Composite boards.....	62
C.1	General	62
C.2	Reactive layers	62
C.3	Tensile strength perpendicular to the board faces	62
C.4	Compatibility	62
C.5	Assessment and judgment	62
	ANNEX D: Freeze/thaw conditioning for use category Y	63
D.1.	Principle	63

D.2. Cycles	63
D.3. Apparatus	63
D.4. Procedure.....	64
D.4.1 Filling the floor trough.....	64
D.4.2 Test panels	64
D.4.3 Arrangement of the test panels	64
D.4.4 Test sequence	65

FOREWORD

Background

This draft ETA-Guideline has been established by the EOTA WG 11.01/04 dealing with fire protective products. This draft ETA-Guideline - Part 4 "Fire protective board, slab and mat products and kits" shall be used in conjunction with Part 1 - "General".

This Complementary Part expands and/or modifies the requirements given in Part 1 – General, taking into account the specific family of products referred to.

This ETA-Guideline has been drafted, taking into account the result of the Standing Committee on Construction's discussions, based on Construct 02/560, to treat fire protective boards either as a component of a kit, or as a product, in which case the ETA will define the necessary other products, in order for the board to be tested to establish a fire resistance classification. The applicability of the resulting fire resistance class(-es) shown in the ETA is (are) limited to the details of the assembly used to perform the fire resistance test(-s).

However, fire protective boards may be used in many end-use conditions and it is economically impossible to test the boards under consideration for every conceivable end-use condition in the framework of an ETA issuing procedure. Therefore, the first generation of ETAs will only cover a limited number of fire resistance tests. With every ETA renewal, the ETA-holder has the opportunity to enlarge the fire resistance test data gradually.

List of reference documents

This draft ETA-Guideline Part 4 incorporates, by dated or undated reference, provisions from other publications. These normative references are cited at the appropriate places in the text and the publications are listed in Annex A of this Part of the ETA-Guideline. For dated references subsequent amendments to, or revisions of these publications, apply to this ETA-Guideline only when incorporated in it by amendment or revision. For undated references the latest dated revision of the publication referred to apply.

SECTION ONE: INTRODUCTION

1. PRELIMINARIES

1.1 Legal basis

The legal basis of the ETA-Guidelines is given in Part 1 "General" - clause 1.1.
This ETA-Guideline supersedes the November 2007 version of this ETAG.

1.2 Status of ETA-Guidelines

The Status of the ETA-Guidelines is given in Part 1 "General" - clause 1.2.

2. SCOPE

2.1 Scope

This Part 4 shall be used in conjunction with Part 1 "General".

This Complementary Part, ETA-Guideline Part 4 - "Fire protective board, slab and mat products and kits" specifies the terminology and definitions, the specific methods of verification, the classification criteria for the fire protective board, slab and mat products and kits and the identification of their component characteristics. Tiles are considered to be boards or slabs of smaller size and are also covered by this ETA-Guideline.

It also gives guidance for the assessment of the specific installation instructions and for the attestation of conformity for such products and kits intended to be used as fire protection products.

This ETA-Guideline is applicable to fire protective board, slab and mat products and kits. For the purpose of this ETA-Guideline, the term "boards" will cover boards, slabs, tiles and mats, even when not explicitly mentioned, except for clause 5.2 and clause 6.2 where distinction has been made.

It can also be used to issue ETAs where the product under assessment is a board or a slab or a mat alone, as far as the ETA-applicant submits the product to a fire resistance assessment, using the appropriate 'characterisation' testing and assessment process. In such cases, the ETA-applicant will refer to other "generic" components required to assemble the product into an assembly, e.g. fixing products, supporting frame and joint material, identified by reference to detailed specifications or to minimum performance characteristics, to which these generic products have to conform. The ETA then specifies the scope of the fire resistance performance for the assembly.

This ETA-Guideline covers fire protective composite board products and boards with finishings (see Annex C), also those which have a specific fire performance (e.g. reactive coatings).

Board kits for forming self-supporting ducts or for cladding sheet metal ducts, for applications such as ventilation, smoke extraction or protection of services, are covered by this ETA-Guideline. ETA-applicants placing such boards on the market may claim these performances, if they wish to do so. However, in these cases, compliance with EN 1507, EN 13403 and the relevant part(-s) of the EN 12101 series needs to be assessed as well.

Fire protective suspended ceiling kits that are tested according to the provisions of EN 1364-2 or CEN/TS 13381-1 and classified according to EN 13501-2 and their components are covered by this ETA-Guideline. Aspects covered by EN 13964:2004, not addressed in this ETA-Guideline, shall also be considered by the Approval Body, as far as relevant for the product or kit under consideration.

Excluded from the scope are suspended ceilings covered by EN 13964:2004, which are not especially intended for fire protective purposes.

Fire sealing and fire stopping products are considered in a separate ETA-Guideline.

2.2 Use categories, products families, kits and systems

2.2.1 General

For the purpose of this ETA-Guideline, the Fire protective products have been divided into:

- Reactive materials

- Renderings and kits based on renderings
- Fire protective board, slab and mat products and kits

In this Part, additional specifications are given for kits based on boards, slabs or mats. The component specifications are either:

- specified in this ETA-Guideline; or
- specified in European technical specifications as referred to in the Construction Products Directive, i.e.
 - harmonised European product standards as published by CEN (see Annex A) or
 - European Technical Approvals as published by EOTA-member bodies.

2.2.2 Use category related to weather exposure

For the purpose of this Part of the ETA-Guideline, the fire protective board, slab and mat products and kits have been divided into product families related to their intended weather-exposure related use. These use categories are based on the general principles as specified in the ETA-Guideline, Part 1, clause 2.2.1. In the framework of this ETA-Guideline, Part 4, the use categories are the following:

- Type X: Fire protective board, slab and mat products and kits intended for all uses (internal, semi-exposed and exposed)
- Type Y: Fire protective board, slab and mat products and kits intended for internal and semi-exposed use
- Type Z₁: Fire protective board, slab and mat products and kits intended for internal use, in high humidity environments¹.
- Type Z₂: Fire protective board, slab and mat products and kits intended for internal use only.

Note 1: Products that meet requirements for type X meet the requirements for all other types. Products that meet requirements for types Y and Z₁ also meet the requirements for type Z₂. However, products that meet the requirements for type Y do not necessarily meet the requirements for type Z₁

Note 2: Requirements relevant for the establishment of the use categories are presented in clauses 6.1.4.1.1, 6.1.7.1, 6.2.3.1, 6.2.4.1 and 6.2.7.1.

2.2.3 Use category related to intended use



For the purpose of this ETAG Part, the fire protective board, slab and mat products and kits have been divided into product families related to their intended fire protective applications. The use category types 1 to 10 are defined in the ETA-Guideline, Part 1 "General".

In the framework of this ETA-Guideline, Part 4:

- the type 8 products, referred to ETA-Guideline, Part 1, clause 2.2.2, cover intended uses where the fire protective board, slab and mat products and kits contribute to the fire resistance of fire separating elements (e.g. incorporation in walls, floors, doors, closures for conveyors, glazed screens, cavity barriers, fire resistant ceilings).
- the type 9 products, referred to ETA-Guideline, Part 1, clause 2.2.2, cover intended uses where the fire protective board, slab and mat products and kits contribute to the fire resistance of other products that penetrate fire separating construction elements (e.g. incorporation in ventilation ducts, smoke extraction ducts, services ducts, chimneys).

¹ These uses apply for internal humidity class 5 in accordance with EN ISO 13788.

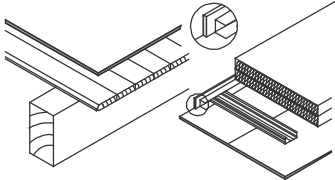
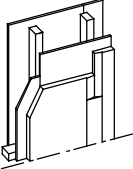
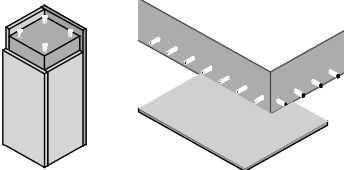
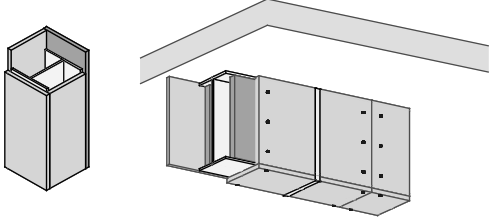
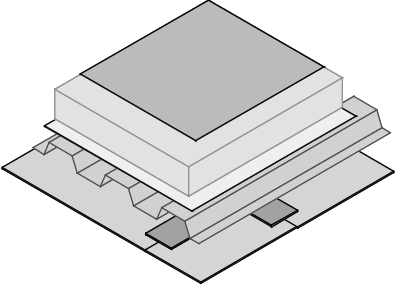
Table 2.1: Illustration of uses defined in ETAG 018-1 for this Part of the ETAG

Protection of	ETAG 018-1 reference	Examples
Horizontal membrane protection	Type 1	
Vertical membrane protection	Type 2	
Load-bearing concrete elements	Type 3	
Load-bearing steel elements	Type 4	
Load-bearing flat concrete profiled sheet composite elements	Type 5	
Fire Protective Products to protect load-bearing concrete filled hollow steel columns	Type 6	

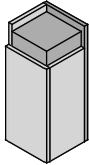
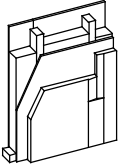
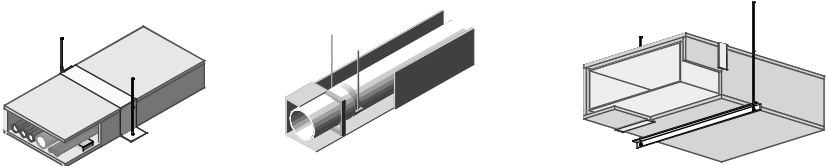
Load-bearing timber elements	Type 7	
Fire separating assemblies with no load-bearing requirements	Type 8	
Fire Protective Products that contribute to the fire resistance of technical services assemblies in buildings	Type 9	
Uses not covered by types 1-9	Type 10	All uses not covered above, except cavity barriers (see ETAG 026).

2.3 Assumptions

Depending on the product families to which the fire protective board, slab and mat products and kits belong, not all the verification methods as given in Chapter 5 might be relevant.

Additional assumptions made are given in Part 1 "General" - clause 2.3

2.4 Use of this ETA-Guideline

Depending on the product to be assessed, and in accordance with the ETA-Guideline scope (clause 2.1), this ETA-Guideline shall be used as follows:

- for kits, based on boards, slabs or mats, the complete ETA-Guideline needs to be taken into account. The "kit" assessment is based on the assessment of kit related verifications (clause 5.1) and the component related verifications as specified in clauses 5.2, 5.3, 5.4, 5.5, 5.6 and/or 5.7 (if and where relevant for the kit under consideration).
- for boards, slabs or mats the only clause of this ETA-Guideline which needs to be taken into account is that which covers board, slab or mat related verifications (clause 5.2). Fire resistance is assessed, based on assembly testing, installed in accordance with ETA-applicant's specifications, taking into account minimum requirements for additional generic components, necessary to perform the test. In this case, and if the other provisions in chapter 6 have been met, the product shall be considered as a fire protective board, slab or mat covered by this ETA-Guideline.

3 TERMINOLOGY

3.1 Common terminology and abbreviations

The common terminology and abbreviations are given in Part 1 "General" - clause 3.1

3.2 Particular terminology and abbreviations

For the purpose of this ETA-Guideline Part 4, the particular terminology and abbreviations as given in Part 1 "General" - Clause 3.2 apply, and additionally, the following specific terminology and abbreviations also apply:

Composite boards (slabs or mats)

Factory made boards, slabs or mats, composed of layers of different materials. In the framework of this ETA-Guideline, board, slab or mat finishings are not considered to be a layer of different material.

Finishing

Factory applied continuous layer of a product in liquid, paste or powder form that, when applied to a surface, forms a film possessing protective, decorative and/or other specific properties.

In the framework of this ETA-Guideline, a distinction is being made between decorative finishings, used to improve the aesthetical aspect of the boards (without changing the fire performance), and finishings which contribute to the performance of the board in case of fire.

Fixing products

- Mechanical fastener

A mechanical fastener is a component intended to be used to fasten boards, slabs or mats to the substrate or supporting frame mechanically and is usually made of a (metal) screw, possibly with a plastic or metal washer, anchors, staples, clips, nails, bolts and nuts, rivets, etc.

- Adhesive

An adhesive is a component intended to be used to join boards, slabs or mats to the substrate or supporting frame by surface bonding and is usually made of organic or mineral substances.

Fixing system

System composed of the mechanical fastener and all other components (e.g. plugs), if relevant, necessary to fasten boards, slabs or mats to the substrate or supporting frame.

Insulation product

An insulation product is a factory made component, usually supplied as boards or slabs, mats or rolls, incorporated behind boards or slabs or between them, intended to increase the thermal insulation of the assembled kit.

Jointing material (sealant)

A jointing material is a component intended to be used to fill and seal the joints between boards, slabs or mats or between boards, slabs or mats and other elements, in order for the complete fire protective board, slab or mat kit to fulfil some or all the requirements as specified in chapter 4. These materials can be:

- preformed materials (e.g. joint strips)
- unformed materials, which remain flexible (e.g. sealants) or become rigid (e.g. mortars) over time
- loose fill materials (e.g. mineral wool)

Joint

A joint is a construction formed by the adjacent parts of two or more products, components or building elements (e.g. between boards, slabs and mats or between boards, slabs or mats and other elements), when these are put together or fixed with, or without, the use of a jointing material. Open joints usually render the fire protective board, slab or mat kit unable to fulfil some or all the requirements as specified in chapter 4.

Kit based on boards, slabs or mats (further referred to as "kit")

For a definition of the term "kit": See EC Guidance Paper C. For kits based on boards, slabs or mats, the kit comprises the boards, slabs or mats, and one or more of the following components: mechanical fasteners; adhesives; sealants; any other component, e.g. profiles, supporting framework and in-fill insulation.

Supporting Framework

Framework that consists of e.g. timber or metal profiles or sections, intended to support fire protective boards, slabs or mats.

SECTION TWO: GUIDANCE FOR THE ASSESSMENT OF THE FITNESS FOR USE

4. REQUIREMENTS

4.0 General

The performance requirements, establishing the fitness for use of fire protective board kits, shall be in accordance with Part 1 "General" - chapter 4, and with the following specific stipulations for this family of products.

The provisions, test and assessment methods in this Guideline, or referred to, have been written based upon the assumed intended working life of the product for the intended use of 10 or 25 years, provided that the product is subject to appropriate use and maintenance in accordance with chapter 7. These provisions are based upon the current state of art and the available knowledge and experience.

4.1 ER 1: Mechanical resistance and stability

Not relevant, see ETA-Guideline, Part 1

4.2 ER 2: Safety in case of fire

See ETA-Guideline, Part 1.

4.3 ER 3: Hygiene, health and the environment

See ETA-Guideline, Part 1.

4.4 ER 4: Safety in use

4.4.1 Mechanical resistance and stability (of fixing systems)

If mechanically fixed, the fire protective kits based on boards shall be sufficiently fixed to ensure that the safety of occupants and passers by is not endangered.

The mechanical fastening shall be ensured through a well designed pattern of mechanical fasteners and a sufficient pull out and pull through resistance of the fixing system and boards used.

4.4.2 Resistance to impact / movement

Assemblies of fire protective kits based on boards shall have sufficient impact resistance to ensure that the safety of occupants and passers-by is not endangered.

This means that the assemblies shall have sufficient impact resistance to withstand accidentally large dynamic loads, from the action of persons or objects, without full or partial collapse causing dangerous (sharp or cutting) fragments, giving risk of falling through, particularly at a change of level, or endangering the safety of other people.

The loads can be in the form of (not exhaustive list):

- impacts resulting from a person falling against the fire protective kits based on boards
- differential air pressure
- impacts resulting from the movement of heavy non -deformable objects such as pieces of furniture or equipment
- slamming of doors
- heavy objects such as furniture and sanitary or heating equipment.

4.4.3 Adhesion

Note 3: This requirement has been placed under ER4 for convenience, but is related to other requirements as well, in particular to ER2.

For fire protective kits based on boards adhered to the substrate, movements which are to be expected under normal use, shall not lead to loss of adhesion in the system. Adhered fire protective kits based on boards shall withstand movements due to temperature and stress variations, except at structural joints, where special precautions shall be taken (see also chapter 7).

4.5 ER 5: Protection against noise

See ETA-Guideline, Part 1.

4.6 ER 6: Energy economy and heat retention

See ETA-Guideline, Part 1.

4.7 Related aspects of durability, serviceability and identification

See ETA-Guideline, Part 1.

5. SPECIFIC METHODS OF VERIFICATION

5.0 General

The methods of verification given in Part 1 "General" - chapter 5 apply, except where modified or specified below.

Table 5.1² Product characteristics and methods of verification and assessment

ER	ETAG Paragraph on product performance	ETAG Paragraph on verification method of product characteristics	
		Kits	Components (Boards, slabs or mats, mechanical fasteners, adhesives & Jointing materials)
ER1		Not relevant for these products	
ER2	4.2.1 Reaction to fire 4.2.2 Fire resistance	5.1.2.1 Reaction to fire 5.1.2.2 Fire resistance	5.2 Boards, slabs or mats 5.2.2.1 Reaction to fire 5.2.2.2 Fire resistance 5.3 Mechanical fasteners 5.3.2.1 Reaction to fire 5.4 Adhesives 5.4.2.1 Reaction to fire 5.5 Jointing materials 5.5.2.1 Reaction to fire 5.6 Insulation products 5.6.2.1 Reaction to fire 5.7 Profiles, framework, studs, etc. 5.7.2.1 Reaction to fire
ER3	4.3.1 Air and water permeability 4.3.2 Release of dangerous substances	5.1.3 Hygiene, health and environment	5.2 Boards, slabs or mats 5.2.3.1 Water permeability 5.2.3.2 Release of dangerous substances 5.3 Mechanical fasteners 5.3.3.1 Release of dangerous substances 5.4 Adhesives 5.4.3.1 Release of dangerous substances 5.5 Jointing materials 5.5.3.1 Release of dangerous substances 5.6 Insulation products 5.6.3.1 Release of dangerous substances 5.7 Profiles, framework, studs, etc. 5.7.3.1 Release of dangerous substances
ER4	4.4.1 Mechanical resistance and stability	5.1.4.1.1 Pull-through resistance of mechanical fasteners 5.1.4.1.2 Shear load resistance of mechanical fastening systems	5.2 Boards, slabs or mats 5.2.4.1 Flexural strength 5.2.4.2 Dimensional stability 5.3 Mechanical fasteners 5.3.4.1 Mechanical resistance and stability 5.3.4.1.1 Pull-out resistance of mechanical fasteners 5.4 Adhesives 5.4.4.1 Mechanical resistance and stability

² Part 4 needs to be read in conjunction with Part 1

			5.7 Profiles, framework, studs, etc. 5.7.4.1 Mechanical resistance and stability
	4.4.2 Resistance to impact/movement	5.1.4.2.1 Resistance to soft body impact 5.1.4.2.2 Resistance to hard body impact 5.1.4.2.3 Resistance to eccentric load	
	4.4.3 Adhesion	5.1.4.3 Adhesion	
ER5	4.5. Protection against noise <ul style="list-style-type: none"> • Airborne sound insulation • sound absorption • Impact sound insulation 	5.1.5 Protection against noise	4.5 Protection against noise
ER6	4.6.1 Thermal resistance 4.6.2 Moisture transfer	5.1.6 Energy economy and heat retention	5.2 Boards, slabs or mats 5.2.6.1 Thermal resistance 5.2.6.2 Water vapour transmission coefficient
			5.6 Insulation products 5.6.6.1 Thermal resistance 5.6.6.2 Water vapour transmission coefficient
			5.7 Profiles, framework, studs, etc. 5.7.6.1 Thermal resistance
	4.7.1 Durability and serviceability	5.1.7.1 Durability and serviceability	5.2 Boards, slabs or mats 5.2.7.1 Durability and serviceability
			5.3 Mechanical fasteners 5.3.7.1 Durability and serviceability
			5.4 Adhesives 5.4.7.1 Durability and serviceability
			5.5 Jointing materials 5.5.7.1 Durability and serviceability
			5.6 Insulation products 5.6.7.1 Durability and serviceability
			5.7 Profiles, framework, studs, etc. 5.7.7.1 Durability and serviceability
	4.7.2 Identification	5.1.7.2 Identification	5.2 Boards, slabs or mats 5.2.7.2 Identification
			5.3 Mechanical fasteners 5.3.7.2 Identification
			5.5 Jointing materials 5.5.7.2. Identification
			5.6 Insulation products 5.6.7.2. Identification
			5.7 Profiles, framework, studs, etc. 5.7.7.2 Identification

5.1 Verification methods for kits

5.1.1 ER 1: Mechanical resistance and stability

Not relevant, see ETA-Guideline, Part 1.

5.1.2 ER 2: Safety in case of fire

5.1.2.1 Reaction to fire

Reaction to fire is treated through the performance of the kits' components, see clauses 5.2.2.1, 5.3.2.1, 5.4.2.1, 5.5.2.1, 5.6.2.1 and 5.7.2.1.

5.1.2.2 Fire resistance

See ETA-Guideline Part 1 and clause 5.2.2.2.

5.1.3 ER 3: Hygiene, health and the environment

See ETA-Guideline Part 1.

5.1.4 ER 4: Safety in use

5.1.4.0 Conditioning and test conditions

5.1.4.0.1 Conditioning

For all "Safety in use" verification methods, the following conditioning shall take place.

The sample boards and mechanical fasteners are conditioned, at (23 ± 2) °C and $(50 \pm 5)\%$ RH, until constant mass, i.e. until two subsequent measurements, with a minimum interval of 24 h, differ less than 0,1 % (except for the test described in clause 5.1.4.1.1.2)..

5.1.4.0.2 Test conditions during testing

During all "Safety in use" verification methods, the following laboratory conditions shall apply: (20 ± 10) °C and $(50 \pm 20)\%$ RH.

5.1.4.1 Mechanical resistance and stability (of fixing systems)

5.1.4.1.1 Pull-through resistance of mechanical fasteners

5.1.4.1.1.1 Introduction

This test shall be carried out for mechanically fixed systems only and establishes the pull-through resistance of a mechanical fastener through the penetration in the fire protective board.

The test is carried out on 5 sample boards, each measuring (250×250) mm nominally.

The apparatus consists of:

- a dynamometer,
- a support (figure 1)

The mechanical fasteners are installed in accordance with the manufacturer's specifications. For the purpose of this test, the mechanical fastener shall be applied in the centre of the samples.

The tensile force for pulling through the mechanical fastener shall be measured with a dynamometer. The tensioning speed is (20 ± 1) mm/min.

The maximum pull-through resistance of each test is expressed in N. The test results, the mode of failure and mean value are recorded in the test report.

5.1.4.1.1.2 After immersion in water

In case the board kit is intended to be used for semi-exposed or exposed external uses, the test as in clause 5.1.4.1.1.1 shall also be conducted after the board has been immersed completely during 1h at (20 ± 10) °C.

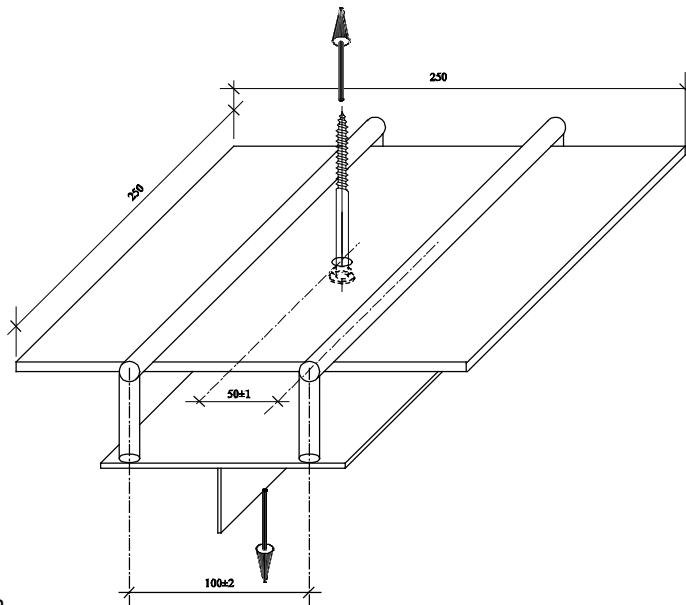

Dimensions in mm

Figure 1: Principle of pull-through test assembly

5.1.4.1.2 Shear load resistance of mechanical fastening systems

This test shall be carried out for mechanically fastened systems only and establishes the shear load resistance of a mechanical fastening system, installed through the fire protective board into a wooden batten (fig. 2).

The test is carried out on 5 sample boards, each measuring 150 mm x 50 mm x d, nominally, where d is the thickness of the board. The apparatus consists of a dynamometer.

One mechanical fastener is installed in each sample at (50 ± 2) mm from the top and (25 ± 2) mm from the sides, in accordance with the manufacturer's specifications. The test rig shall prevent torque, i.e. prevent eccentric forces being applied resulting in an additional loading.

The shear failure load shall be measured with a dynamometer. The tensioning speed is $(0,5 \pm 0,1)$ mm/min.

Only when the board is completely loose from the substrate, shall the test be terminated, and the result registered.

The maximum shear (failure) load of each test is expressed in N. The test results, the mode of failure and mean value are recorded in the test report.

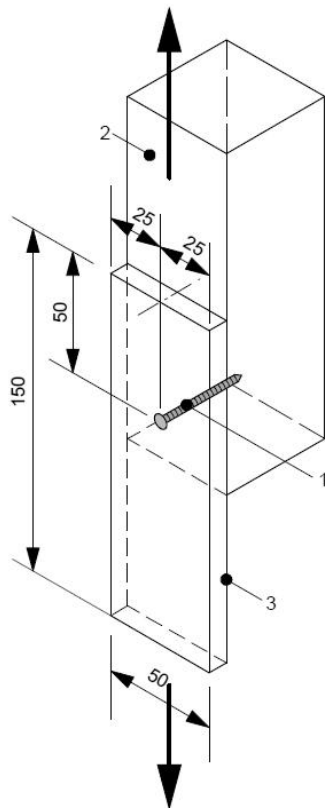

- Key
- 1 Mechanical fastener
 - 2 Wooden batten (t x 50 x 150)
 - 3 Board

Dimensions in mm

t: thickness of the batten

Figure 2: Principle of shear load resistance test assembly

5.1.4.2 Resistance to impact / movement

5.1.4.2.1 Resistance to functional failure from soft body impact load – 50 kg bag

Test method as specified in EOTA TR001:2003, clause 1, with the following modifications:

The test rig is composed of a solid wall, in front of which one full size sample board (at least 1,00 m x 2,00 m) is fixed, on a supporting frame or profiles and with fixing system or adhesive as specified and installed in accordance with the manufacturer's specifications.

5.1.4.2.2 Resistance to functional failure from hard body impact load – 0,5 kg steel ball

Test method as specified in EOTA TR001:2003, clause 2, with the following modifications:

The test rig is composed of a solid wall, in front of which one full size sample board (at least 1,00 m x 2,00 m) is fixed, on a supporting frame or profiles and with fixing system or adhesive as specified and installed in accordance with the manufacturer's specifications.

5.1.4.2.3 Resistance to functional failure from eccentric vertical load

Usually, manufacturers will not claim resistance to functional failure from eccentric vertical load. However, if such claim is made, testing of fire protective board kits for support of an eccentric vertical downward load shall be performed as described in ISO/DIS 8413, with the following amendments and modifications:

The test rig is composed of a solid wall, in front of which one full size sample board (at least 1,00 m x 2,00 m) is fixed, on a supporting frame or profiles and with fixing system or adhesive as specified and installed in accordance with the manufacturer's specifications. The test needs to be repeated for each variation of fixing system and/or adhesive and for each fixing pattern.

At half height, two frames are attached to the board, at (500 ± 10) mm from each other, each with two mechanical fasteners, which are 150 mm apart. At a distance of (300 ± 10) mm from the surface of the board, a vertical load is attached in the centre of the connection between the two frames, during (24 ± 1) h (see figure 3). The load is to be

determined by the ETA-applicant.

Different boards are to be used if more than one load is tested.

This fail/pass test has a successful result if the frame does not collapse. The test report shall show the eccentric vertical load that the board resisted and the failure mode (punch through of the frame, shear of mechanical fasteners, etc.). The test report shall list any visible damage (e.g. minor cracks).

When fixing systems are used that penetrate the fire protective board, the ETA shall contain the necessary precautions, ensuring that the fire protective assembly still fulfils the fire protective behaviour claimed. These specified precautions shall also be taken into account when assessing fire resistance (clause 5.2.2. 2).

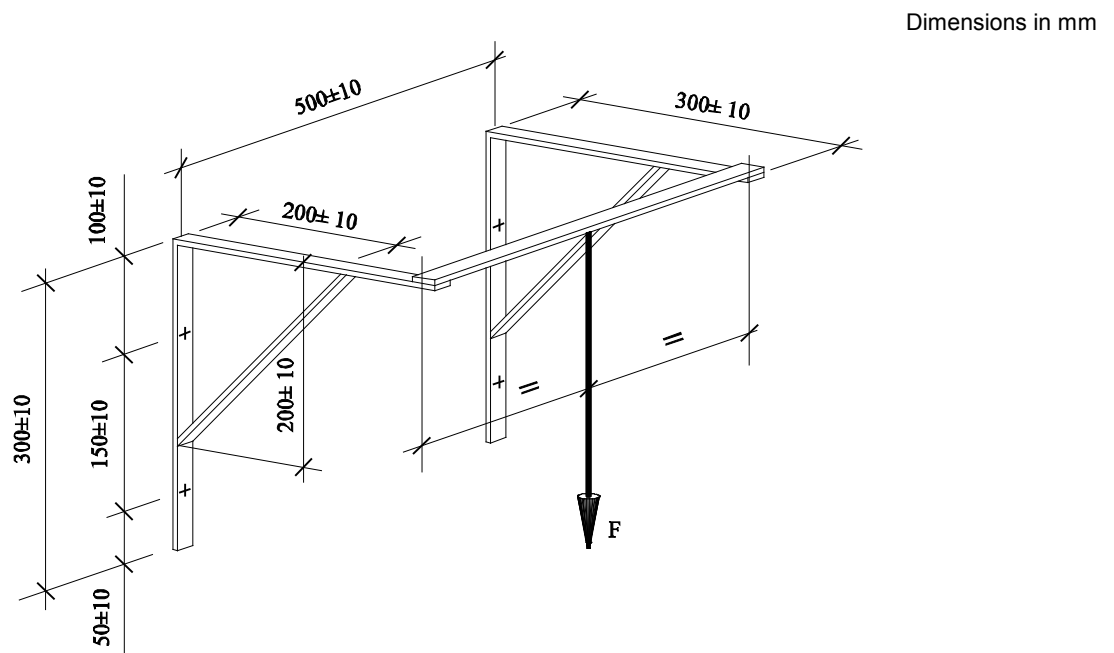

Figure 3: Principle of resistance to eccentric load test assembly

5.1.4.3 Adhesion

Note 4: This requirement has been placed under ER4 for convenience, but is related to other requirements as well, in particular to ER2.

This test shall be carried out for adhered systems only and establishes bond strength between substrate, adhesive and fire protective board. This test shall be conducted on each substrate for which the fire protective kits based on boards is intended to be used.

The boards are adhered in accordance with the manufacturer's specifications.

The test is performed on five samples, measuring diameter 80 mm nominally, which are cut through the board and just into the substrate. The five samples can be drawn from one board. The metal plates are affixed to these areas with a suitable adhesive (see figure 4).

After allowing the adhesive to cure, in accordance with the ETA-applicant's specifications, the bond strength is measured with a dynamometer at a tensioning speed of (10 ± 1) mm/min.

The failure load of each test is expressed in MPa. The test results, the mode of failure and mean value are recorded in the test report.

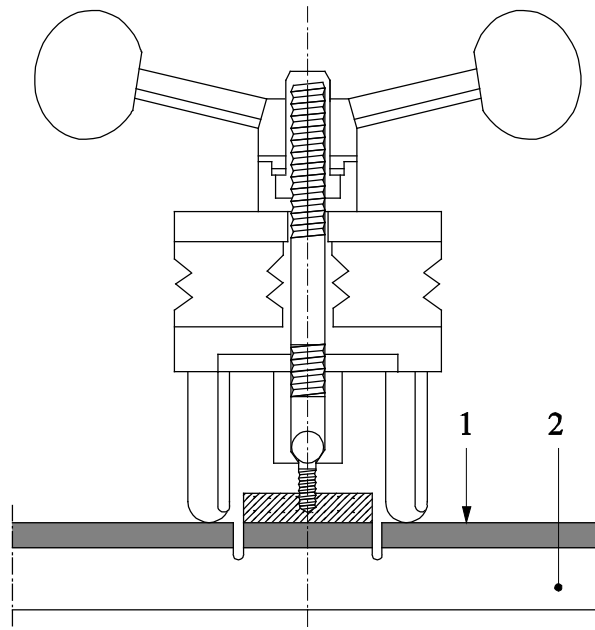

Key
 1 Board
 2 Substrate

Figure 4: Principle of adhesion resistance test assembly

5.1.5 ER 5: Protection against noise

See ETA-Guideline Part 1.

5.1.6 ER 6: Energy economy and heat retention

See ETA-Guideline Part 1.

5.1.7 Related aspects of durability, serviceability and identification

5.1.7.1 Durability and serviceability requirements

The verifications according to clauses 5.2.7.1, 5.3.7.1, 5.4.7.1, 5.5.7.1, 5.6.7.1 and 5.7.7.1 shall be conducted on the boards, adhesives, fixing systems and/or jointing materials which are intended to be used as a part of the kit, unless similar tests have been performed on the basis of European product standards or European Technical Approvals.

5.1.7.2 Identification

Products and materials used in the fire protective kits based on boards shall be identified, either through verification methods specified in a European product standard, a European Technical Approval or as specified in the component specifications (clauses 5.2.7.2, 5.3.7.2, 5.4.7.2, 5.5.7.2, 5.6.7.2 and 5.7.7.2).

The identification also includes manufacturer's specification as regards distances between supporting profiles or framework elements, number and pattern of mechanical fasteners, etc. (if and where applicable).

5.2 Verification methods for boards, slabs and mats

Clause 5.2 of this ETA-Guideline provides verification methods for boards, slabs and mats as a fire protective kit component and for fire protective boards, slabs or mats as a single product (see clause 2.4.)

5.2.0 General

The performance characteristics for boards shall be verified in accordance with European technical specifications for the boards under consideration:

- harmonised European product standards as published by CEN (see Annex A) or

– European Technical Approvals as published by EOTA, unless this ETA-Guideline considers product characteristics (incl. identification, serviceability and durability) that are not covered by those European technical specifications.

If such technical specifications are not available, the specifications referred to in this sub-clause shall be used for verification purposes.

Products and kit components shall only be subjected to the verification methods specified below if the corresponding characteristics are relevant for the product or kit component under consideration and as far as relevant for its fitness for the intended use(-s). Characteristics for which the NPD-option is not allowed (see this ETA-Guideline, Part 1, table 6.1) shall always be verified.

All boards will be dried to constant mass ensuring that the performances derived are reproducible. To prevent disproportionate costs, the method should be as rapid as possible.

In normal circumstances, drying will take place in an oven at $(105 \pm 2) ^\circ\text{C}$ (method 1). If this might lead to chemical reactions which influence performance, the following methods may be applied.

- Conditioning method 2: in an oven at $(40 \pm 2) ^\circ\text{C}$
- Conditioning method 3: in laboratory conditions $(23 \pm 2) ^\circ\text{C}$ and $(50 \pm 5) \text{RH}$

Conditioning lasts until constant mass, i.e. until two subsequent weight measurements differ less than 0,1% over a $(24 \pm 1) \text{h}$ period or at least 28 days.

The ETA shall specify the conditioning method used.

5.2.1 ER 1: not relevant

5.2.2 ER 2: Safety in case of fire

5.2.2.1 Reaction to fire

One or more of the following options shall apply. However, certain end use applications of some products cannot be satisfactorily classified using EN 13501-1 (e.g. facades).

- The product (if the ETA is being issued for a fire protective board product) or individual kit components (if the ETA is being issued for a fire protective board kit), shall be tested, using the test method(s) relevant for the corresponding reaction to fire class, in order to be classified according to EN 13501-1
- The products or individual kit components are considered to satisfy the requirements for performance Class A1 of the characteristic reaction to fire, in accordance with the provisions of EC Decision 96/603/EC (as amended) on the basis of their listing in that Decision. Alternatively, EC Decisions (e.g. Decision 2003/593/EC) may allow products or components to be classified without the need for further testing (CWFT).

The single burning item test shall be performed in accordance with EN 13823, using the mounting and fixing provisions presented in Annex B of this document.

Note 5: On a voluntary basis, the ETA-applicant can have other assemblies tested than the one presented in Annex B. Those additional test results will then also be included in the ETA by the Approval Body.

5.2.2.2 Fire resistance³

Fire protective boards, slabs and mats are covered by this ETA-Guideline, if at least one fire resistance test result is available, in accordance with the provisions in ETA-Guideline, Part 1.

For fire protective boards, slabs and mats which are part of normal building service installations or smoke control systems, the boards, slabs and mats shall be tested, using the test method relevant for the corresponding fire resistance application, in order to be classified according to EN 13501-3 or EN 13501-4.

Fire resistance will be performed on assemblies, consisting of the board, slab or mat and other construction products (e.g. supporting framework, adhesive, fixing system and joint material) necessary to install an assembly, which is being used in practice by the ETA-applicant, in accordance with manufacturer's specifications.

The test report shall contain the product characteristics and installations details of all the products necessary to install the assembly.

³ Part 4 needs to be read in conjunction with Part 1

5.2.3 ER 3: Hygiene, health and the environment

5.2.3.1 Water permeability

The boards, slabs and mats shall be tested in accordance with EN 12467:2005, clause 7.3.3.

5.2.3.2 Release of dangerous substances

See ETA-Guideline, Part 1.

5.2.4 ER 4: Safety in use

5.2.4.1 Flexural strength

The boards, slabs and mats shall be tested in accordance with EN 12467:2005, clause 7.3.2 (for boards) or EN 12089 (for slabs and mats).

5.2.4.2 Dimensional stability

The boards, slabs and mats shall be tested in accordance with EN 318 (for boards) or EN 1604 (for slabs and mats).

5.2.5 ER 5: see ETA-Guideline Part 1

5.2.6 ER 6: Energy economy and heat retention

5.2.6.1 Thermal resistance

For boards, slabs and mats thermal conductivity shall be based upon measurements carried out in accordance with EN 12667 or if relevant EN 12939 or EN 993-14.

The thermal performance of fire protective boards which may also be used for their thermal insulation purposes, i.e. products with a declared thermal resistance higher than 0,25 m².K/W or a declared thermal conductivity at 10 °C lower than 0,060 W/(m.K), shall be determined and verified in accordance with EN ISO 13787.

5.2.6.2 Water vapour transmission coefficient

The boards, slabs and mats shall be tested in accordance with EN ISO 12572 (for boards) or EN 12086 (for slabs and mats). This characteristic is also closely related to ER3.

5.2.7 Related aspects of durability, serviceability and identification

5.2.7.1 Durability and serviceability requirements

5.2.7.1.1 Relationship between durability and working life

Taking into account that not all products and kits on the market are intended for a long working life, this ETA-Guideline distinguishes three verification approaches:

- Working life of 25 years: Favourable assessment for the relevant complete durability verification (see clause 5.2.7.1.2)
- Working life of 10 years: Favourable assessment for the basic durability verification (see clause 5.2.7.1.3)
- Working life of 10 years: Unfavourable assessment for the basic durability assessment (see clause 5.2.7.1.3), but sufficient documented proof to demonstrate experience of 10 years favourable performance (see clause 5.2.7.1.4).

Additionally, the durability of the adhesion of finishings (if any) needs to be verified.

5.2.7.1.2 Complete durability assessment

5.2.7.1.2.0 Introduction

Satisfactory performance for the following tests leads to a presumption that the working life of the product is 25 years. The intended weather exposure category depends on the satisfactory performance for the following tests. Complete durability assessment is done through artificial ageing.

5.2.7.1.2.1 Resistance to deterioration caused by water

This test needs to be performed only for intended uses: Types X and Z₁.

Types Y and Z₂ shall be tested if more than accidental wetting is to be expected.

The boards, slabs and mats shall be tested in accordance with EN 12467:2005, clause 7.3.5.

5.2.7.1.2.2 Resistance to soak/dry

This test needs to be performed only for intended uses: Type X and Z₁. Types Y and Z₂ shall be tested if more than accidental wetting is to be expected.

The boards, slabs and mats shall be tested in accordance with EN 12467:2005, clause 7.3.6.

5.2.7.1.2.3 Resistance to freeze/thaw

This test needs to be performed only for intended uses: Types X and Y. Types Z₁ and Z₂ shall be tested if frost is to be expected inside the building.

The boards, slabs and mats shall be tested in accordance with EN 12467:2005, clause 7.4.1. For type Y, Annex D of this ETAG replaces paragraphs 3 to 8 of EN 12467:2005, sub-clause 7.4.1.3.

5.2.7.1.2.4 Resistance to heat/rain

This test needs to be performed only for intended uses: Type X. Types Y, Z₁ and Z₂ shall be tested if more than accidental wetting is to be expected.

The boards, slabs and mats shall be tested in accordance with EN 12467:2005, clause 7.4.2.

5.2.7.1.3 Basic durability assessment

Satisfactory performance for the following tests leads to a presumption that the working life of the product is 10 years, for internal uses only (types Z₁ and Z₂). Basic durability assessment is done through indirect testing, i.e. the measurement of "proxy" characteristics that are correlated to actual performance and hence durability.

- Flexural strength: see clause 5.2.4.1.
- Dimensional stability: see clause 5.2.4.2.
- Tensile strength perpendicular to the plane of the board, slab or mat: test to be performed in accordance with EN 319 (for boards) or EN 1607 (for slabs and mats).
- Tensile strength parallel with the plane of the board, slab or mat: test to be performed in accordance with EN 789 (for boards) or EN 1608 (for slabs and mats).
- Compressive strength of the board, slab or mat: test to be performed in accordance with EN 789 (for boards) or EN 826 (for slabs and mats).

Note 6:

- Basic durability assessment is regarded as a way to obtain a favourable general impression of the expected working life of the product under assessment, through the verification of proxy characteristics. The Approval Body may wish to obtain further supporting information from the manufacturer (e.g. references).
- With the term "proxy characteristics", product properties are being referred to, through which it is possible, by indirect testing, to obtain a basis of assessment of the characteristic durability, without the use of direct testing, natural or artificial weathering or ageing.

In particular cases, i.e. where Approval Bodies have justifiable doubts about the fire behaviour of products over time (e.g. based on the results of other durability assessment as foreseen in this ETA-Guideline, or known bad experiences for particular products in particular end use conditions), they are allowed to perform small scale tests after artificial ageing to indicate adequate behaviour. In case such small scale tests would point to important deterioration of fire behaviour, the Approval Body shall either limit the working life or, in consultation with the ETA-applicant, foresee protective measures (e.g. protecting the fire protective boards, slabs or mats from weathering influences). Until harmonized European small scale tests are available, the Approval Body is allowed to base its small scale testing on methods accepted in the Member State of use of the kit.

5.2.7.1.4 Demonstration of experience of 10 years favorable performance

In case the product or kit component does not meet the requirements as set out in clause 5.2.7.1.2 and clause 5.2.7.1.3, the ETA-applicant has the opportunity to provide documented proof that the product under consideration has been used for at least 10 years.

The requirements regarding documented proof shall be decided by the Approval Body on a case-by-case basis, but shall at least consist of the following:

- Evidence showing that the product used in the works has been exposed to conditions specified in the claimed ETA scope
- Evidence showing that the product used in works has been manufactured in accordance with the same manufacturing specifications
- Evidence from at least 5 different sites (more may be required if a number of different installation techniques, intended exposures and/or climates are claimed)
- Additional evidence may be, for example, natural weathering/ageing data which give a direct indication of durability or which enable performance tests to be carried out on aged material, thus allowing the degradation in performance to be determined.

On the basis of the documented proof provided, the Approval Body may restrict the use of the product as specified in the ETA. If the Approval Body considers the evidence provided as sufficient, the working life as specified in the ETA shall be 10 years.

Note 7: If Approval bodies are confronted with ETA-applicants that use this possibility successfully, they are requested to inform the WG convenor. Collection of such data can lead to the development of a progress file, adjusting requirements set for basic durability (see clause 5.2.7.1.3).

5.2.7.1.5 Adhesion of finishings

The adhesion of finishings shall be determined in accordance with EN 24624.

5.2.7.2 Identification

Note 8: In accordance with clause 9.1.1 of the ETA -Guideline, Part 1, the Approval Body may require additional information and may adopt other verification methods.

5.2.7.2.1 Length, Width

The dimensions shall be specified in accordance with EN 12467:2005, clause 5.3.2 (for boards) or EN 822 (for slabs and mats).

5.2.7.2.2 Thickness

The thickness shall be specified in accordance with EN 12467:2005, clause 5.3.3 (for boards) or EN 823 (for slabs and mats)

5.2.7.2.3 Dimensional tolerances

The dimensional tolerances shall be specified in accordance with EN 12467:2005, clause 5.3.4 (for boards) or EN 13162 (for mats) or EN 13467 (for slabs)

5.2.7.2.4 Shape

The shape shall be specified in accordance with EN 12467:2005, clause 5.3.5 (for boards) or EN 824 (for slabs and mats)

5.2.7.2.5 Apparent density

The apparent density shall be specified in accordance with EN 12467:2005, clause 5.4.2 (for boards) or EN 1602 (for slabs and mats)

5.2.7.2.6 Finishings

All finishings shall be identified, either by reference to⁴:

- Harmonised product standards
- European Technical Approvals, based on other ETA-Guidelines or CPD Article 9.2.
- Non-harmonised European product standards
- Non-harmonised International product standards
- Descriptive identification, identifying the products by their composing materials and their function

In any case, significant properties (mechanical, physical, chemical, ...) and their tolerances shall be given. In those cases where the above listed product specifications do not specify test methods for identification, the test methods used shall be based on European standards, International standards, EOTA Technical Reports, UEAtc Guidelines, Nordtest standards or RILEM test methods⁵.

Ultimately, a formulation, a manufacturer's specific reference or a similar unique specification of the finishing(-s) may also be accepted.

Note 9: Finishings based on reactive materials are covered by Annex C.

5.3 Verification methods for Components: Mechanical fasteners

5.3.0 General

The performance characteristics for mechanical fasteners shall be verified in accordance with European technical specifications for the mechanical fasteners under consideration:

- harmonised European product standards as published by CEN (see Annex A) or
- European Technical Approvals as published by EOTA,

unless this ETA-Guideline considers product characteristics (incl. identification, serviceability and durability) that are not covered by those European technical specifications.

If such technical specifications are not available, the specifications referred to in this sub-clause shall be used for verification purposes.

Kit components shall only be subjected to the verification methods specified below if the corresponding characteristics are relevant for the component under consideration and as far as relevant for its fitness for the intended use(-s). Characteristics for which the NPD-option is not allowed (see this ETA-Guideline, Part 1, table 6.1) shall always be verified.

5.3.1 ER 1: not relevant

5.3.2 ER 2: Safety in case of fire

5.3.2.1 Reaction to fire

One or more of the following options shall apply.

- The individual kit components shall be tested, using the test method(s) relevant for the corresponding reaction to fire class, in order to be classified according to EN 13501-1
- The individual kit components are considered to satisfy the requirements for performance Class A1 of the characteristic reaction to fire, in accordance with the provisions of EC Decision 96/603/EC (as amended) on the basis of their listing in that Decision. Alternatively, EC Decisions (e.g. Decision 2003/593/EC) may allow products or components to be classified without need for further testing (CWFT).

⁴ Preference shall be given to the identification method which is highest on the list.

⁵ Preference shall be given to test methods from the organisation which is highest on the list.

5.3.3 ER 3: Hygiene, health and the environment

5.3.3.1 Release of dangerous substances

See ETA-Guideline, Part 1.

5.3.4 ER 4: Safety in use

5.3.4.1 Mechanical resistance and stability (of mechanical fasteners)

5.3.4.1.1 Pull-out resistance of mechanical fasteners

This test method shall be carried out for mechanically fixed systems only and establishes the pull-out resistance of a mechanical fastener. This test shall be conducted on each substrate for which the fire protective kits based on boards is intended to be used.

The test is carried out on 5 sample substrates, each measuring at least (300 ± 20) mm nominally.

The apparatus consists of:

- a dynamometer,
- a support as shown in figure 5
- standard substrates: depending on the substrates the kit is intended to be fastened to, pull-out tests will be performed on the following substrates:
 - Concrete containing granules of 8 to 10 mm in accordance with EN 1766 (type MC 0,40)
 - Category I clay units in accordance with EN 771-1.
 - Category I calcium silicate units in accordance with EN 771-2.
 - Category I aggregate concrete units (dense and lightweight aggregate) in accordance with EN 771-3.
 - Category I autoclaved aerated concrete units in accordance with EN 771-4.
 - Category I manufactured stone units in accordance with EN 771-5.
 - Category I dimensioned natural stone units in accordance with EN 771-6.
 - Continuously hot-dip zinc coated structural steel sheet, nominally 1,00mm thick, type S280 GD, in accordance with EN 10147
 - Oriented strand board (OSB), type OSB/2, thickness 15 mm in accordance with EN 300

The sample boards and mechanical fasteners are conditioned, at (23 ± 2) °C and (50 ± 5) %RH, until constant mass, i.e. until two subsequent measurements, with a minimum interval of 24 h, differ less than 0,1 %.

The mechanical fastener is installed in accordance with the manufacturer's specifications.

The test shall be carried out at (20 ± 10) °C and (50 ± 20) %RH. The tensile strength for pulling out the mechanical fastener shall be measured with a dynamometer. The tensioning speed is (20 ± 2) mm/min. The application of the load has to be controlled.

The pull-out resistance of each test is expressed in N. The test results, the mode of failure and mean value are recorded in the test report.

5.3.5 ER 5: not relevant here, see ETA-Guideline Part 1

5.3.6 ER 6: not relevant here

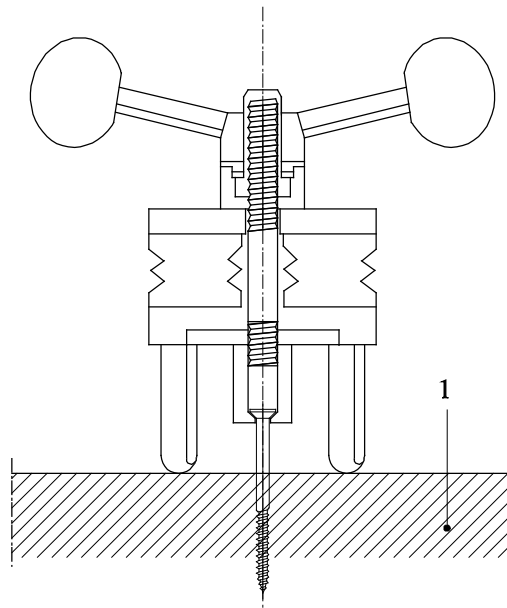

Key
1 Substrate

Figure 5: Principle of pull-out test assembly

5.3.7 Related aspects of durability, serviceability and identification

5.3.7.1 Durability and serviceability requirements

5.3.7.1.0 General

The behaviour of mechanical fasteners can be influenced by corrosion and the degradation of the coating. Therefore, the following shall be considered:

5.3.7.1.1 Corrosion

No special test conditions are required, if the conditions given in clause 6.3.7.1.1 are complied with. If the mechanical fasteners are to be used in particularly aggressive conditions or atmospheres with extreme chemical pollution, special considerations including testing are necessary, taking into account the environmental conditions and the available experience.

5.3.7.1.2 Coating

The durability of the coating that ensures the suitability and the load-bearing behaviour of the mechanical fasteners shall be shown. No special test conditions are given in this ETA-Guideline for checking the durability of any coating, because it depends on the type of coating. Appropriate tests shall be decided on by the responsible Approval Body.

The following environmental conditions shall be taken into account in assessing durability of coatings:

Dry internal conditions

- high alkalinity ($\text{pH} \geq 13,2$)
- temperature in range -5 °C to $+40\text{ °C}$

Other environmental conditions

- high alkalinity ($\text{pH} \geq 13,2$)
- temperature in range -40 °C to $+80\text{ °C}$
- condensed water
- chlorides
- sulphur dioxide

- nitrogen oxide
- ammonia

Zinc coatings (electroplated or hot dip galvanized) need not be subjected to testing if used under dry internal conditions.

5.3.7.2 Identification

The Approval Body shall verify the following properties:

- product description (e.g. self-tapping screw, self drilling screw and drywall screw)
- type of metal and protection
- dimensions and design of the mechanical fastener

Note 10: In accordance with clause 9.1.1 of the ETA -Guideline, Part 1, the Approval Body may require additional information and may adopt other verification methods.

5.4 Verification methods for Components: Adhesives

5.4.0 General

The performance characteristics for adhesives shall be verified in accordance with European technical specifications for the adhesives under consideration:

- harmonised European product standards as published by CEN (see Annex A) or
- European Technical Approvals as published by EOTA,

unless this ETA-Guideline considers product characteristics (incl. identification, serviceability and durability) that are not covered by those European technical specifications.

If such technical specifications are not available, the specifications referred to in this sub-clause shall be used for verification purposes.

Kit components shall only be subjected to the verification methods specified below if the corresponding characteristics are relevant for the component under consideration and as far as relevant for its fitness for the intended use(-s). Characteristics for which the NPD-option is not allowed (see this ETA-Guideline, Part 1, table 6.1) shall always be verified.

5.4.1 ER 1: not relevant

5.4.2 ER 2: Safety in case of fire

5.4.2.1 Reaction to fire

One or more of the following options shall apply.

- The individual kit components shall be tested, using the test method(s) relevant for the corresponding reaction to fire class, in order to be classified according to EN 13501-1
- The products or individual kit components are considered to satisfy the requirements for performance Class A1 of the characteristic reaction to fire, in accordance with the provisions of EC Decision 96/603/EC (as amended) on the basis of their listing in that Decision. Alternatively, EC Decisions (e.g. Decision 2003/593/EC) may allow products or components to be classified without the need for further testing (CWFT).

5.4.3 ER 3: Hygiene, health and the environment

5.4.3.1 Release of dangerous substances

See ETA-Guideline, Part 1.

5.4.4 ER 4: Safety in use

5.4.4.1 Mechanical resistance and stability (of adhesives)

5.4.4.1.1 Peel resistance

The peel resistance shall be tested in accordance with EN 1372.

5.4.4.1.2 Shear strength

The shear resistance shall be tested in accordance with EN 1373.

5.4.5 ER 5: not relevant here

5.4.6 ER 6: not relevant here

5.4.7 Related aspects of durability, serviceability and identification

5.4.7.1 Durability and serviceability requirements

5.4.7.1.1 Determination of freeze/thaw stability

The resistance to freeze/thaw shall be tested in accordance with EN 1239.

5.4.7.2 Identification

Note 11: In accordance with clause 9.1.1 of the ETA -Guideline, Part 1, the Approval Body may require additional information and may adopt other verification methods.

5.4.7.2.1 Product description

The ETA shall specify the type of Adhesive in accordance with EN 923.

5.4.7.2.2 Determination of viscosity

The viscosity shall be tested in accordance with EN 12092.

5.4.7.2.3 Determination of density

The density shall be tested in accordance with EN 542.

5.5 Verification methods for Components: Jointing materials

5.5.0 General

The performance characteristics for jointing materials shall be verified in accordance with European technical specifications for the jointing materials under consideration:

- harmonised European product standards as published by CEN (see Annex A) or
- European Technical Approvals as published by EOTA,

unless this ETA-Guideline considers product characteristics (incl. identification, serviceability and durability) that are not covered by those European technical specifications.

If such technical specifications are not available, the specifications referred to in this sub-clause shall be used for verification purposes.

Kit components shall only be subjected to the verification methods specified below if the corresponding characteristics are relevant for the component under consideration and as far as relevant for its fitness for the intended use(-s). Characteristics for which the NPD-option is not allowed (see this ETA-Guideline, Part 1, table 6.1) shall always be verified.

5.5.1 ER 1: not relevant here

5.5.2 ER 2: Safety in case of fire

5.5.2.1 Reaction to fire

One or more of the following options shall apply.

- The individual kit components shall be tested, using the test method(s) relevant for the corresponding reaction to fire class, in order to be classified according to EN 13501-1
- The products or individual kit components are considered to satisfy the requirements for performance Class A1 of the characteristic reaction to fire, in accordance with the provisions of EC Decision 96/603/EC (as amended) on the basis of their listing in that Decision. Alternatively, EC Decisions (e.g. Decision 2003/593/EC) may allow products or components to be classified without the need for further testing (CWFT).

5.5.3 ER 3: Hygiene, health and the environment

5.5.3.1 Release of dangerous substances

See ETA-Guideline, Part 1.

5.5.7 Related aspects of durability, serviceability and identification

5.5.7.1 Durability and serviceability requirements

5.5.7.1.1 Durability

Depending on the nature of the jointing material, the following verification methods shall be used:

- Unformed materials, which remain flexible (e.g. sealants): The jointing material shall be tested in accordance with EN ISO 11431.
- Preformed materials (e.g. joint strips): EN 12365-1
- Metals: see clause 5.3.7.1
- Plastics: The jointing material shall be tested in accordance with EN 12365-1
- Unformed materials, which become rigid over time (e.g. mortars): The durability shall be determined in accordance with prEN 1015-20
- Loose fill materials (e.g. mineral wool): The dimensional stability shall be determined in accordance with EN 1604.

5.5.7.1.2 Serviceability

5.5.7.1.2.1 Tensile strength

Depending on the nature of the jointing material, the following verification methods shall be used:

- Unformed materials, which remain flexible (e.g. sealants): The jointing material shall be tested in accordance with EN ISO 8339, at 23°C and -20°C. If claimed, the test can also be performed at -40°C.
- Preformed materials (e.g. joint strips): EN 12365-1
- Metals: The jointing material shall be tested in accordance with EN 10002-1
- Plastics: The jointing material shall be tested in accordance with EN ISO 527-1 and EN ISO 527-2.
- Unformed materials, which become rigid over time (e.g. mortars): The jointing material shall be tested in accordance with EN 1015-11.

5.5.7.1.2.2 Adhesion/cohesion

Depending on the nature of the jointing material, the following verification methods shall be used:

- Unformed materials, which remain flexible (e.g. sealants):
 - At variable temperatures: The jointing material shall be tested in accordance with EN ISO 9047.
 - After water immersion: The jointing material shall be tested in accordance with EN ISO 10590.
- Preformed materials (e.g. joint strips): The jointing material shall be tested in accordance with EN 12365-1
- Unformed materials, which become rigid over time (e.g. mortars): The jointing material shall be tested in accordance with EN 1015-12.
- Loose fill materials (e.g. mineral wool): The tensile strength, perpendicular to its faces, shall be determined in accordance with EN 1607.

5.5.7.2 Identification

Product description: Information regarding the nature of the product (e.g. silicone, polyurethane, 1 or components) and its application method

Unformed materials, which remain flexible (e.g. sealants) shall be classified in accordance with EN ISO 11600.

Preformed materials (e.g. joint strips):

- Metals shall be identified in accordance with EN 10020 or EN 10088.
- Plastics shall be identified in accordance with relevant European or international product specification

Unformed materials, which become rigid over time (e.g. mortars) shall be identified in accordance with EN 998-1 or EN 998-2.

Loose fill materials (e.g. mineral wool) shall be identified in accordance with EN 13162.

Note 12: In accordance with clause 9.1.1 of the ETA-Guideline Part 1, the Approval Body may require additional information and may adopt other verification methods.

5.6 Verification methods for Components: Insulation products

Clause 5.6 of this ETA-Guideline provides verification methods for insulation as a fire protective kit component. Insulation products that are intended to be put on the market as fire protective boards, slabs or mats as a single product are covered by clause 5.2 (see also clause 2.4.)

5.6.0 General

The performance characteristics for insulation products shall be verified in accordance with European technical specifications for the products under consideration:

- harmonised European product standards as published by CEN (see Annex A) or
- European Technical Approvals as published by EOTA,

unless this ETA-Guideline considers product characteristics (incl. identification, serviceability and durability) that are not covered by those European technical specifications.

If such technical specifications are not available, the specifications referred to in this sub-clause shall be used for verification purposes.

Kit components shall only be subjected to the verification methods specified below if the corresponding characteristics are relevant for the component under consideration and as far as relevant for its fitness for the intended use(-s). Characteristics for which the NPD-option is not allowed (see this ETA-Guideline, Part 1, table 6.1) shall always be verified.

5.6.1 ER 1: not relevant here

5.6.2 ER 2: Safety in case of fire

5.6.2.1 Reaction to fire

One or more of the following options shall apply. However, certain end use applications of some products may not be able to be satisfactorily classified using EN 13501-1 (e.g. facades).

- The individual kit components shall be tested, using the test method(s) relevant for the corresponding reaction to fire class, in order to be classified according to EN 13501-1
- The products or individual kit components are considered to satisfy the requirements for performance Class A1 of the characteristic reaction to fire, in accordance with the provisions of EC Decision 96/603/EC (as amended) on the basis of their listing in that Decision. Alternatively, EC Decisions (e.g. Decision 2003/593/EC) may allow products or components to be classified without the need for further testing (CWFT).

5.6.3 ER 3: Hygiene, health and the environment

5.6.3.1 Release of dangerous substances

See ETA-Guideline, Part 1.

5.6.4 ER 4: not relevant here

5.6.5 ER 5: not relevant here

5.6.6 ER 6: Energy economy and heat retention

5.6.6.1 Thermal resistance

For boards, slabs and mats thermal conductivity shall be based upon measurements carried out in accordance with EN 12667 or if relevant EN 12939 or EN 993-14.

5.6.6.2 Water vapour transmission coefficient

The boards and slabs shall be tested in accordance with EN 12086. This characteristic is also closely related to ER3.

5.6.7 Related aspects of durability, serviceability and identification

5.6.7.1 Durability and serviceability requirements

5.6.7.1.1 Moisture resistance

The short term water absorption by partial immersion shall be determined in accordance with EN 1609 including any facings or coatings.

5.6.7.1.2 Dimensional stability under constant normal laboratory conditions

Dimensional stability under constant normal laboratory conditions (23 °C/50 % RH) shall be determined in accordance with EN 1603.

5.6.7.2 Identification

Note 13: In accordance with clause 9.1.1 of the ETA -Guideline, Part 1, the Approval Body may require additional information and may adopt other verification methods.

5.6.7.2.1 Length, Width

The dimensions shall be specified in accordance with EN 822.

5.6.7.2.2 Thickness

The thickness shall be specified in accordance with EN 823.

5.6.7.2.3 Dimensional tolerances

The dimensional tolerances shall be specified in accordance with the relevant product standard or ETA.

5.6.7.2.4 Shape

The shape shall be specified in accordance with EN 824.

5.6.7.2.5 Density

The (apparent) density shall be determined in accordance with EN 1602.

5.6.7.2.6 Finishings

All finishings shall be identified, either by reference to⁶:

- Harmonised product standards
- European Technical Approvals, based on other ETA-Guidelines or on CPD article 9.2
- Non-harmonised European product standards
- Non-harmonised International product standards
- Descriptive identification, identifying the products by their composing materials and their function

⁶ Preference shall be given to the identification method which is highest on the list.

In any case, significant properties (mechanical, physical, chemical, ...) and their tolerances shall be given. In those cases where the above listed product specifications do not specify test methods for identification, test methods used, shall be based on European standards, International standards, EOTA Technical Reports, UEAtc Guidelines, Nordtest standards or RILEM test methods⁷.

Ultimately, a formulation, a manufacturer's specific reference or a similar unique specification for the finishings may also be accepted.

5.7 Verification methods for Components: Profiles, framework, studs, etc.

5.7.0 General

The performance characteristics for profiles, framework, studs, etc. shall be verified in accordance with European technical specifications for the products under consideration:

- harmonised European product standards as published by CEN (see Annex A) or
- European Technical Approvals as published by EOTA,

unless this ETA-Guideline considers product characteristics (incl. identification, serviceability and durability) that are not covered by those European technical specifications.

If such technical specifications are not available, the specifications referred to in this sub-clause shall be used for verification purposes.

Kit components shall only be subjected to the verification methods specified below if the corresponding characteristics are relevant for the component under consideration and as far as relevant for its fitness for the intended use(-s). Characteristics for which the NPD-option is not allowed (see this ETA-Guideline, Part 1, table 6.1) shall always be verified.

5.7.1 ER 1: not relevant

5.7.2 ER2: Safety in case of fire

5.7.2.1 Reaction to fire

One or more of the following options shall apply. However, certain end use applications of some products may not be able to be satisfactorily classified using EN 13501-1 (e.g. facades).

- The individual kit components shall be tested, using the test method(s) relevant for the corresponding reaction to fire class, in order to be classified according to EN 13501-1
- The products or individual kit components are considered to satisfy the requirements for performance Class A1 of the characteristic reaction to fire, in accordance with the provisions of EC Decision 96/603/EC (as amended) on the basis of their listing in that Decision. Alternatively, EC Decisions (e.g. Decision 2003/593/EC) may allow products or components to be classified without the need for further testing (CWFT).

5.7.3 ER3: Hygiene, health and the environment

5.7.3.1 Release of dangerous substances

See ETA-Guideline, Part 1.

5.7.4 ER4: Safety in use

5.7.4.1 Mechanical resistance and stability

5.7.4.1.1 General

The load-bearing capacity and suitability of the supporting framework of a kit shall be determined taking account of EN 1990:2002 either by calculation, testing or a combination of calculation assisted by testing (see clauses 5.7.4.1.2 to 5.7.4.1.4).

However, usually, the supporting framework has no load-bearing function and only transmits loads onto structural elements (e.g. ceilings, walls).

In such cases, the mechanical resistance of the supporting framework may be considered satisfactory, if the assembly tests required in this ETA-Guideline (e.g. SBI, resistance to fire, impact resistance) have been performed with satisfactory result.

⁷ Preference shall be given to test methods from the organisation which is highest on the list.

Extended application and engineering knowledge may be used to verify supporting framework, profiles, etc. that are made out of the same material and have comparable intended use(-s).

5.7.4.1.2 Calculation

The supporting framework shall be calculated in accordance with the following, depending upon the materials used:

- EN 1993: Design of steel structures
- EN 1995: Design of timber structures
- EN 1999: Design of aluminium structures

5.7.4.1.3 Testing

Where the supporting framework cannot be calculated or where a testing approach is preferred, the profiles are tested on a case-by-case basis, taking into account the particular design and intended use.

Only test methods which are part of this ETA-Guideline (or Progress file), may be used, or, alternatively, those specified in European standards (CEN), International standards (ISO), EOTA Technical Reports, UEAtc Guidelines, Nordtest standards or RILEM test methods⁸. If such alternatives are being used, the ETA will specify the method in sufficient detail (the specification's reference and edition, and, if relevant, any deviations made, compared with the specified method).

Where bending resistance is required, the test method specified in EN 13964:2004, clause 5, shall be used.

5.7.4.1.4 Verification assisted by testing

Where calculation rules or material properties given in the referenced Eurocodes according to clause 5.7.4.1.2 are not sufficient or where economy may result from tests on the products under consideration, part of the design procedure may be performed on the basis of tests. This design assisted by testing shall be done according to Annex D of EN 1990:2002.

5.7.5 ER 5: not relevant here

5.7.6 ER6: Energy economy and heat retention

5.7.6.1 Thermal resistance

Usually, the ETA-applicant will allow EN ISO 10456 to be used to determine the thermal resistance of the supporting framework.

Where a manufacturer makes specific claims for the thermal performance of a fire protective board kit, the thermal characteristics of the frame members may be determined using relevant tests and calculations, e.g. given in EN 12412-2 and EN ISO 10077-2.

5.7.7 Aspects of durability, serviceability and identification

5.7.7.1 Durability and serviceability requirements

If supporting profiles or a framework are components of the kit, then these shall also be assessed, with regard to durability and serviceability, on the basis of European (CEN) or International standards (ISO). Because such components can be designed in a large number of possibilities and materials, the assessment method shall be considered on a case-by-case basis, taking into account that a number of verification methods already foresee the incorporation of these components in a number of assembly tests (e.g. SBI, fire resistance, impact resistance).

In order to demonstrate the durability and serviceability of the supporting framework, the Approval Body may make use of information derived from documented sources, such as listed experience or previous approval procedures. The file shall make clear under what conditions of climate and product usage the satisfactory experience has been gained.

⁸ Preference shall be given to test methods from the organisation which is highest on the list.

The following references shall be used for aluminium, steel or timber supporting framework:

- Aluminium: The corrosion protection of aluminium supporting framework shall be classified in accordance with EN 1396.
- Steel: The corrosion protection of steel supporting framework shall be classified in accordance with EN 10327 or EN 10152. Coatings of steel parts with zinc compatible organic coating shall be verified according to EN ISO 12944-3 (paints, coatings) or of steel parts with equivalent coil coating according to EN 10169-1.
- Timber: Compliance of the members of timber framework with the requirements of section 4 of EN 1995-1-1 shall be verified.

5.7.7.2 Identification

The Approval Body shall verify the following:

- Product description
- Nature of the profiles, framework, studs, ...: Classification in accordance with EN 10142, EN 10152, EN 10169-1, EN 10214 or EN 10215 (for steel), EN 573-3 (for aluminium) or EN 1912 (for timber).
- Dimensions with tolerances
- Shape

Note 14 In accordance with clause 9.1.1 of the ETA-Guideline, Part 1, the Approval Body may require additional information and may adopt other verification methods.

6. ASSESSING AND JUDGING THE FITNESS OF KITS AND COMPONENTS FOR INTENDED USE

6.0 General

The assessment and judging shall be performed in accordance with Part 1 "General" - chapter 6, except where modified or specified below.

6.1 Assessment and judging for kits

6.1.0 General

Unless other specifications are given in this chapter, extended application of the test results (if any) shall be declared in the ETA, under the responsibility of the Approval Body.

The Approval Body shall assess and judge the fitness for use of the kit for each characteristic that was verified. Every declaration in the ETA represents a favourable assessment of the kit's performance, taking into account the intended use, made under the responsibility of the Approval Body.

6.1.1 ER 1: Mechanical resistance and stability

Not relevant, see ETA-Guideline, Part 1.

6.1.2 ER 2: Safety in case of fire

6.1.2.0 Introduction

See also ETA-Guideline, Part 1

6.1.2.1 Reaction to Fire

Not relevant for kits, only for the components, see clauses 6.2.2.1, 6.3.2.1, 6.4.2.1, 6.5.2.1, 6.6.2.1 and 6.7.2.1.

6.1.2.2 Fire resistance

For a Kit based on boards intended to be used as a fire protective kit based on boards "No performance declared" shall not be an option. The fire resistance shall be declared in accordance with EN 13501-2, EN 13501-3 and/or EN 13501-4. The board kits shall be designated according to the element or elements they are intended to protect (see clause 2.2).

Classification of the assemblies, the fire protective products and kits were tested in, can be established using the characterisation data (see clause 9 of the ETA-Guideline, Part 1 "General"), which is collected from the tests, together with relevant calculation methods, e.g. from Eurocodes.

The ETA shall include the characterisation data and the field of application.

6.1.3 ER 3: Hygiene, health and the environment

See ETA-Guideline Part 1.

6.1.4 ER 4: Safety in use

6.1.4.1 Mechanical resistance and stability (of fixing systems)

6.1.4.1.1 Pull-through resistance of mechanical fasteners

The ETA shall specify the mean value of five test results. This requirement is only applicable for those board kits which include mechanical fastening systems.

Products intended for types Z_1 and Z_2 uses, shall not be subjected to this test after immersion in water. For products intended for types X and Y, the Approval Body shall assess adequacy of performance or specifications preventing exposure to water.

6.1.4.1.2 Shear load resistance of mechanical fastening systems

The ETA shall specify the mean value of five test results. This requirement is only applicable for those board kits which include mechanical fastening systems.

The test result and the mode of failure might present to the Approval Body the need to impose restrictions on the use of the kit in the ETA.

6.1.4.2 Resistance to impact / movement

6.1.4.2.1 Resistance to functional failure from soft body impact load – 50 kg bag

The ETA shall specify the soft body impact resistance that the board, installed in accordance with the manufacturer's specifications, resisted, in accordance with EOTA TR001:2003 and taking into account the recommendations presented in Annex A. This requirement is only applicable for board kits claiming soft body impact resistance. "No performance determined" is an option.

6.1.4.2.2 Resistance to functional failure from hard body impact load – 0,5 kg steel ball

The ETA shall specify the hard body impact resistance that the board, installed in accordance with the manufacturer's specifications, resisted, in accordance with EOTA TR001:2003 and taking into account the recommendations presented in Annex A. This requirement is only applicable for board kits claiming hard body impact resistance. "No performance determined" is an option.

6.1.4.2.3 Resistance to functional failure from eccentric vertical load

The ETA shall specify the eccentric vertical load that the board, installed in accordance with the manufacturer's specifications, resisted. This requirement is only applicable for board kits claiming resistance to eccentric vertical load. "No performance determined" is an option.

6.1.4.3 Adhesion

The ETA shall specify the mean value of five test results. This requirement is only applicable for those board kits which include adhesives.

The test result and the mode of failure might present to the Approval Body the need to impose restrictions on the use of the kit in the ETA.

6.1.5 ER 5: Protection against noise

See ETA-Guideline Part 1.

6.1.6 ER 6: Energy economy and heat retention

See ETA-Guideline Part 1.

6.1.7 Related aspects of durability, serviceability and identification

6.1.7.1 Durability and serviceability requirements

The board kits shall be categorised, according to their weather exposure (types X, Y, Z₁ and Z₂), based on the assessment of all components (see clauses 6.2.7.1, 6.3.7.1, 6.4.7.1, 6.5.7.1, 6.6.7.1 and 6.7.7.1). Satisfaction of all the relevant requirements can lead to a predicted working life of 10 or 25 years (see clause 6.2.7.1).

6.1.7.2 Identification

Products and materials used in the fire protective kits based on boards shall be identified, either through assessment criteria specified in a European product standard, a European Technical Approval or as specified in the component specifications (clauses 6.2.7.2, 6.3.7.2, 6.4.7.2, 6.5.7.2, 6.6.7.2 and 6.7.7.2).

6.2 Assessment and judging for boards, slabs and mats

6.2.0 General

Clause 6.2 of this ETA-Guideline provides assessment and judgement methods for boards, slabs and mats as a fire protective kit component and for fire protective boards, slabs or mats as a single product (see clause 2.4.)

The Approval Body shall assess and judge the fitness for use of the product or kit component for each characteristic that was verified. Every declaration in the ETA represents a favorable assessment of the product or component's performance, taking into account the intended use, made under the responsibility of the Approval Body.

6.2.1 ER 1: not relevant

6.2.2 ER 2: Safety in case of fire

6.2.2.1 Reaction to fire

The boards, slabs and mats shall be classified according to either EN 13501-1, Decision 96/603/EC (as amended, Class A1) or an appropriate Classified without Further Testing (CWFT) Decision

6.2.2.2 Fire resistance

A board, slab or mat shall be considered to be a "fire protective board", if at least one fire resistance classification is declared in the ETA, in accordance with the provisions in ETA-Guideline, Part 1 (see also clause 2.4 of this ETA-Guideline, Part 4).

The ETA shall contain all the required information as specified in clause 9.1 of this ETA-Guideline.

Note 15: Manufacturers should be made aware that different classes may be required in the EEA Member States, depending on the intended use(-s) of the boards.

6.2.3 ER 3: Hygiene, health and the environment

6.2.3.1 Water permeability

When tested in accordance with EN 12467:2005, clause 7.3.3, traces of moisture may appear on the under surface of the board, slab or mat, but in no instance shall there be any formation of drops of water. "No performance determined" is an option for boards or slabs that do not claim water tightness (only for boards of weather exposure types Y, Z₁ and Z₂).

6.2.3.2 Release of dangerous substances

See ETA-Guideline, Part 1.

6.2.4 ER 4: Safety in use

6.2.4.1 Flexural strength

For boards: when tested in accordance with EN 12467:2005, clause 7.3.2, the mean modulus of rupture (MOR) of the sheets, expressed in MPa, shall be declared.

For slabs and mats: when tested in accordance with EN 12089, the conventional bending strength, expressed in kPa, shall be declared.

"No performance determined" is an option for boards, slabs and mats that do not claim flexural strength (only for boards of weather exposure types Z₁ and Z₂).

6.2.4.2 Dimensional stability

Results from the tests will be declared and verified with relevant European product specifications.

6.2.5 ER 5: not relevant here

6.2.6 ER 6: Energy economy and heat retention

6.2.6.1 Thermal resistance

The measured value of the thermal conductivity (λ -value) shall be declared.

6.2.6.2 Water vapour transmission coefficient

The measured value of the water vapour transmission coefficient (μ -value) shall be declared.

6.2.7 Related aspects of durability, serviceability and identification

6.2.7.1 Durability and serviceability

6.2.7.1.1 Classification related to durability assessment

Durability assessment of the boards, slabs and mats leads to two classifications.

6.2.7.1.1.1 Related to working life

Taking into account that not all products and kits on the market are intended for a long working life, this ETA-Guideline distinguishes three verification approaches:

- Working life of 25 years: Favourable assessment for the relevant complete durability verification (see clause 6.2.7.1.2). The relevancy depends on the intended weather exposure use categories claimed.
- Working life of 10 years: Favourable assessment for the basic durability verification (see clause 6.2.7.1.3)
- Working life of 10 years: Unfavourable assessment for the basic durability assessment (see clause 6.2.7.1.3), but sufficient documented proof to demonstrate experience of 10 years favourable performance (see clause 6.2.7.1.4).

Note 16: If the working life of the product under consideration is 10 years, only weather exposure types Z₁ and Z₂ are possible.

6.2.7.1.1.2 Related to intended weather exposure

In accordance with clause 2.2.2, four use categories have been distinguished:

- Type X: all assessment specified in clause 6.2.7.1.2 leads to a favourable result.
- Type Y: at least the assessment specified in clauses 6.2.7.1.3 (basic durability assessment) and 6.2.7.1.2.4 (freeze/thaw resistance) leads to a favourable result.
- Type Z₁: at least the assessment specified clauses 6.2.7.1.3 (basic durability assessment), 6.2.7.1.2.1 (resistance to deterioration caused by water) and 6.2.7.1.2.2 (resistance to soak/dry) lead to a favourable result.

- Type Z₂: at least the assessment specified in clause 6.2.7.1.3 (basic durability assessment) leads to a favourable result.

The assessment in accordance with the clauses 6.2.7.1.2, 6.2.7.1.3 and 6.2.7.1.4 leads to the declaration in the ETA of the use category(-ies) achieved. The individual verification results obtained shall not be declared.

Note 17: EN 12467:2005, which is the basis for the above mentioned tests, provides pass/fail criteria. These criteria have been established for the product covered by that standard and may, therefore, not be applicable for the products covered by this ETA-Guideline. Because the ETA-Guideline covers a wide variety of products, it is at present not possible to fix uniform criteria in this ETA-Guideline.

The Approval Bodies shall judge on a case by case basis whether test results can be considered as favourable and explain the judgement criteria they used in the ER accompanying the ETA. For products that are very similar to those covered by EN 12467:2005, the criteria might still apply.

Note 18: Other paragraphs (clauses 6.1.4.1.1, 6.2.3.1, 6.2.4.1 and 6.2.7.1) in this ETA-Guideline are part of the overall Approval Body's assessment leading to determining the weather exposure type(-s).

6.2.7.1.2 Complete durability assessment

6.2.7.1.2.1 Resistance to deterioration caused by water

When tested in accordance with EN 12467:2005, clause 7.3.5, the ratio R_L as defined in EN 12467:2005, clause 7.3.5.4 shall be the basis for determining the use category(-ies) achieved. "No performance determined" is an option for boards, slabs or mats that do not claim resistance to water deterioration (only for boards, slabs or mats of weather exposure types Y and Z₂).

6.2.7.1.2.2 Resistance to soak/dry

When tested in accordance with EN 12467:2005, clause 7.3.6, the ratio R_L as defined in EN 12467:2005, clause 7.3.6.4 shall be the basis for determining the use category(-ies) achieved. The ETA shall declare the number of soak/dry cycles. "No performance determined" is an option for boards, slabs or mats that do not claim resistance to water deterioration (only for boards, slabs or mats of weather exposure types Y and Z₂).

6.2.7.1.2.3 Resistance to freeze/thaw

When tested in accordance with EN 12467:2005, clause 7.4.1, the ratio R_L as defined in EN 12467:2005, clause 7.4.1.4 and the number of freeze/thaw cycles shall be the basis for determining the use category(-ies) achieved. "No performance determined" is an option for boards, slabs or mats that do not claim freeze/thaw resistance (only for boards, slabs or mats of weather exposure types Z₁ and Z₂).

6.2.7.1.2.4 Resistance to heat/rain

When tested in accordance with EN 12467:2005, clause 7.4.2, any visible cracks, de-lamination or other defects in the boards, slabs or mats shall not be of such a degree as to affect their intended use. "No performance determined" is an option for boards, slabs or mats that do not claim heat/rain resistance (only for boards, slabs or mats of weather exposure types Y, Z₁ and Z₂).

6.2.7.1.3 Basic durability assessment

Test results shall be verified with relevant technical European product specifications (harmonised standards or ETAs).

6.2.7.1.4 Demonstration of experience of 10 years favourable performance

In case the ETA applicant uses the opportunity to provide documented proof that the product under consideration has been used for at least 10 years, the ETA shall specify which evidence was presented to the Approval Body.

The Approval Body may restrict the use of the product as specified in the ETA. If the Approval Body considers the evidence provided as sufficient, the working life as specified in the ETA shall be 10 years. The evidence provided becomes part of the Approval Body's confidential file.

6.2.7.1.5 Adhesion of finishings

The adhesion of finishings shall be declared in accordance with EN 24624

6.2.7.2 Identification

6.2.7.2.1 Length, width

Length(-s) and with(-s) shall be declared in the ETA

6.2.7.2.2 Thickness

Thickness(-es) shall be declared in the ETA

6.2.7.2.3 Dimensional tolerances

Dimensional tolerances shall be declared in the ETA

6.2.7.2.4 Shape

Shape(-s) shall be declared in the ETA

6.2.7.2.5 Apparent density

The (apparent) density shall be declared in the ETA

6.2.7.2.6 Finishings

All finishings shall be fully identified in accordance with clause 5.2.7.2.6.

6.3 Assessment and judging for Components: Mechanical fasteners

6.3.0 General

The Approval Body shall assess and judge the fitness for use of the kit component for each characteristic that was verified. Every declaration in the ETA represents a favourable assessment of the component's performance, taking into account the intended use, made under the responsibility of the Approval Body.

6.3.1 ER 1: not relevant

6.3.2 ER 2: Safety in case of fire

6.3.2.1 Reaction to fire

The mechanical fasteners shall be classified according to either EN 13501-1, Decision 96/603/EC (as amended, Class A1) or an appropriate Classified Without Further Testing (CWFT) Decision.

6.3.3 ER 3: Hygiene, health and the environment

6.3.3.1 Release of dangerous substances

See ETA-Guideline, Part 1.

6.3.4 ER 4: Safety in use

6.3.4.1 Mechanical resistance and stability

6.3.4.1.1 Pull-out resistance of mechanical fasteners

The ETA shall specify the mean value of the five results.

6.3.5 ER 5: not relevant here

6.3.6 ER 6: not relevant here

6.3.7 Related aspects of durability, serviceability and identification

6.3.7.1 Durability and serviceability

6.3.7.1.1 Corrosion

6.3.7.1.1.0 Introduction

The assessment/testing required with respect to corrosion resistance will be dependent upon the specification of the mechanical fastening system in relation to its use. Supporting evidence that corrosion will not occur is not required if the mechanical fasteners are protected against corrosion of steel parts, as set out below:

6.3.7.1.1.1 Mechanical fasteners for use in structures subject to external atmospheric exposure or exposure in permanently damp internal conditions

The metal parts of the mechanical fasteners shall be made of an appropriate grade of stainless steel. The grade of stainless steel suitable for the various service environments (marine, industrial, etc.) shall be in accordance with existing rules. Grade A4 of EN ISO 3506 or equivalent may be used under internal or other environmental conditions if no particularly aggressive conditions exist.

However, in particularly aggressive conditions such as permanent, alternating immersion in seawater or the splash zone of seawater, chloride atmosphere of indoor swimming pools or atmosphere with extreme chemical pollution (e.g. in desulphurisation plants or road tunnels, where de-icing materials are used) special consideration shall be given to corrosion resistance. According to current experience, in general the types of stainless steel given above will not have sufficient corrosion resistance in those aggressive conditions.

6.3.7.1.1.2 Mechanical fasteners intended for use in structures subject to dry, internal conditions

In general, no special corrosion protection is necessary for steel parts as coatings provided for preventing corrosion during storage prior to use, to ensure proper functioning (e.g. a zinc coating with a minimum thickness of 5 microns) is considered sufficient. Malleable cast iron parts in general, e.g. type B32 -12 and W40 05 to ISO 5922 do not require any protection.

Where a form of protection (material or coating) other than those mentioned above is specified, it will be necessary to provide evidence in support of its effectiveness in the defined service conditions; with due regard to the aggressiveness of the conditions concerned.

If mechanical fastening systems involve the use of different metals, these shall be electrolytically compatible with each other. In dry internal conditions, carbon steel is compatible with malleable cast iron.

6.3.7.1.2 Coating

Assessment of the durability of the coating is based on the type of coating and the intended conditions of use (i.e. dry internal or external conditions).

6.3.7.2 Identification

Relevant identification properties shall be declared in the ETA, for:

- Product description
- Type of metal and protection
- Dimensions and design

6.4 Assessment and judging for Components: adhesives

6.4.0 General

The Approval Body shall assess and judge the fitness for use of the kit component for each characteristic that was verified. Every declaration in the ETA represents a favourable assessment of the component's performance, taking into account the intended use, made under the responsibility of the Approval Body.

6.4.1 ER 1: not relevant

6.4.2 ER 2: Safety in case of fire

6.4.2.1 Reaction to fire

Adhesives shall be classified according to either EN 13501-1, Decision 96/603/EC (as amended, Class A1) or an appropriate Classified Without Further Testing (CWFT) Decision.

6.4.3 ER 3: Hygiene, health and the environment

6.4.3.1 Release of dangerous substances

See ETAG-Guideline Part 1

6.4.4 ER 4: Safety in use

6.4.4.1 Mechanical resistance and stability

The measured values derived from the test methods and the mode of failure shall be declared.

6.4.5 ER 5: not relevant here

6.4.6 ER 6: not relevant here

6.4.7 Related aspects of durability, serviceability and identification

6.4.7.1 Durability and serviceability

The measured values derived from the test methods shall be declared.

6.4.7.2 Identification

Relevant identification properties shall be declared in the ETA, for:

- product description
- viscosity
- density

6.5 Assessment and judging for Components: Jointing materials

6.5.0 General

The Approval Body shall assess and judge the fitness for use of the kit component for each characteristic that was verified. Every declaration in the ETA represents a favourable assessment of the component's performance, taking into account the intended use, made under the responsibility of the Approval Body.

6.5.1 ER 1: not relevant

6.5.2 ER 2: Safety in case of fire

6.5.2.1 Reaction to fire

The jointing materials shall be classified according to either EN 13501-1, Decision 96/603/EC (as amended, Class A1) or an appropriate Classified Without Further Testing (CWFT) Decision.

6.5.3 ER 3: Hygiene, health and the environment

6.5.3.1 Release of dangerous substances

See ETA-Guideline, Part 1.

6.5.4 ER 4: not relevant here

6.5.5 ER 5: not relevant here

6.5.6 ER 6: not relevant here

6.5.7 Related aspects of durability, serviceability and identification

6.5.7.1 Durability and serviceability

6.5.7.1.1 Durability

Depending on the nature of the jointing material, the following assessment will be performed:

- Unformed materials, which remain flexible (e.g. sealants): When tested in accordance with EN ISO 11431, the elongation shall still be 60% or higher. "No performance determined" is not an option.
- Preformed materials (e.g. joint strips): EN 12365-1
- Metals: see clause 6.3.7.1
- Plastics: The jointing material shall be classified in accordance with EN 12365-1
- Unformed materials, which become rigid over time (e.g. mortars): When tested in accordance with prEN 1015-20, the results shall be declared. "No performance determined" is not an option.
- Loose fill materials (e.g. mineral wool): When tested in accordance with EN 1604, the dimensional stability shall be declared. "No performance determined" is not an option.

6.5.7.1.2 Serviceability

6.5.7.1.2.1 Tensile/flexural strength

Depending on the nature of the jointing material, the following assessment will be performed:

- Unformed materials, which remain flexible (e.g. sealants): When tested in accordance with EN ISO 8339, the secant tensile modulus at 23°C and at -20°C shall be declared. If claimed, it shall also be declared at -40°C. "No performance determined" is not an option.
- Preformed materials (e.g. joint strips): EN 12365-1
- Metals: When tested in accordance with EN 10002-1, the tensile strength shall be declared. "No performance determined" is an option.
- Plastics: When tested in accordance with EN ISO 527-1 and -2, the tensile strength shall be declared. "No performance determined" is an option.
- Unformed materials, which become rigid over time (e.g. mortars): When tested in accordance with EN 1015-12, the flexural strength shall be declared. "No performance determined" is not an option.

6.5.7.1.2.2 Adhesion/cohesion

Depending on the nature of the jointing material, the following assessment will be performed:

- Unformed materials, which remain flexible (e.g. sealants):
 - At variable temperatures: When tested in accordance with EN ISO 9047, the test samples shall pass the test as defined in clause 7 of EN ISO 11600. "No performance determined" is not an option, unless the ETA declares the temperature range in which the fire protective board kits should be used under normal conditions.
 - After water immersion: When tested in accordance with EN ISO 10590, the test samples shall pass the test as defined in clause 7 of EN ISO 11600. "No performance determined" is not an option, unless the ETA declares that the fire protective board kits should not be exposed to any moisturising.
- Preformed materials (e.g. joint strips): The jointing material shall be classified in accordance with EN 12365-1
- Unformed materials, which become rigid over time (e.g. mortars): When tested in accordance with EN 1015-12, the adhesive strength shall be declared. "No performance determined" is not an option.
- Loose fill materials (e.g. mineral wool): When tested in accordance with EN 1607, the tensile strength, perpendicular to its faces, shall be declared. "No performance determined" is an option.

6.5.7.2 Identification

- Product description
- Unformed materials, which remain flexible (e.g. sealants): shall be of class F in accordance with EN ISO 11600.
- Preformed materials (e.g. joint strips):
 - Metals shall be identified in accordance with EN 10020 or EN 10088.

- Plastics shall be identified in accordance with relevant European or international product specification
- Unformed materials, which become rigid over time (e.g. mortars): shall be identified in accordance with EN 998-1 or EN 998-2.
- Loose fill materials (e.g. mineral wool): shall be identified in accordance with EN 13162.

6.6 Assessment and judging for Components: insulation products

6.6.0 General

Clause 6.6 of this ETA-Guideline provides assessment and judgement methods for insulation as a fire protective kit component. Insulation products that are intended to be put on the market as fire protective boards, slabs or mats as a single product are covered by clause 6.2 (see also clause 2.4.)

The Approval Body shall assess and judge the fitness for use of the kit component for each characteristic that was verified. Every declaration in the ETA represents a favorable assessment of the component's performance, taking into account the intended use, made under the responsibility of the Approval Body.

6.6.1 ER 1: not relevant here

6.6.2 ER 2: Safety in case of fire

6.6.2.1 Reaction to fire

The insulation products shall be classified according to either EN 13501 -1, Decision 96/603/EC (as amended, Class A1) or an appropriate Classified Without Further Testing (CWFT) Decision.

6.6.3 ER 3: Hygiene, health and the environment

6.6.3.1 Release of dangerous substances

See ETA-Guideline, Part 1

6.6.4 ER 4: not relevant here

6.6.5 ER 5: not relevant here

6.6.6 ER 6: Energy economy and heat retention

6.6.6.1 Thermal resistance

The measured value of the thermal conductivity at ambient temperature (λ -value) shall be declared.

6.6.6.2 Water vapour transmission coefficient

The measured value of the water vapour transmission coefficient (μ -value) shall be declared.

6.6.7 Related aspects of durability, serviceability and identification

6.6.7.1 Durability and serviceability

6.6.7.1.1 Moisture resistance

The water absorption rate in kg/m² shall be declared in the ETA

6.6.7.1.2 Dimensional stability

The relative changes in length shall be declared in the ETA.

6.6.7.2 Identification

6.6.7.2.1 Length, width

Length(-s) and width(-s) shall be declared in the ETA

6.6.7.2.2 Thickness

Thickness(-es) shall be declared in the ETA

6.6.7.2.3 Dimensional tolerances

Dimensional tolerances shall be declared in the ETA

6.6.7.2.4 Shape

Shape(-s) shall be declared in the ETA

6.6.7.2.5 Density

The (apparent) density shall be declared in the ETA

6.6.7.2.6 Finishings

All finishings shall be fully identified in accordance with clause 5.6.7.2.5.

6.7 Assessment and judging for Components: Profiles, framework, studs, etc.

6.7.0 General

The Approval Body shall assess and judge the fitness for use of the kit component for each characteristic that was verified. Every declaration in the ETA represents a favourable assessment of the component's performance, taking into account the intended use, made under the responsibility of the Approval Body.

6.7.1 ER 1: not relevant

6.7.2 ER 2: Safety in case of fire

6.7.2.1 Reaction to fire

The component shall be classified according to either EN 13501-1, Decision 96/603/EC (as amended, Class A1) or an appropriate Classified Without Further Testing (CWFT) Decision.

6.7.3 ER 3: Hygiene, health and the environment

6.7.3.1 Release of dangerous substances

See ETA-Guideline, Part 1.

6.7.4 ER 4: Safety in use

6.7.4.1 Mechanical resistance and stability

6.7.4.1.1 General

Usually, the performance of the supporting framework will have been determined by calculations, testing or a combination of calculation and testing. Alternatively, adequate information regarding the physical properties and dimensions, in accordance with 6.7.7.2, shall be provided.

6.7.4.1.2 Calculation, with or without assistance through testing

The properties of structural components shall be specified in the ETA with regard to the need of fulfilling the requirements applicable to the end use of the component.

This may be done by expressing the properties in terms of:

- characteristic values for strength and other cross section properties from which the load-bearing capacities of the assembled kit installed in the works can be calculated, or
- design values provided that the Nationally Determined Parameters (NDP) applicable to works have been taken into account.

Any Nationally Determined Parameters (NDP) used shall be declared.

6.7.4.1.3 Testing

Where the performance of the supporting framework has been determined by testing or a combination of calculation and testing, then the principles of the relevant structural Eurocodes shall be followed to determine an overall performance relating to strength and stiffness.

The statistical analysis of the test results to determine the characteristic value is to be undertaken according to EN 1990:2002.

6.7.5 ER 5: not relevant here

6.7.6 ER 6: Energy economy and heat retention

6.7.6.1 Thermal resistance

Only where the manufacturer claims thermal performance the thermal conductivity at ambient temperature (λ -value) shall be declared.

6.7.7 Aspects of durability, serviceability and identification

6.7.7.1 Durability and serviceability requirements

The technical file and the ETA shall contain details of the supporting framework materials and the means by which their durability has been proven. Where the evidence is from previous assessments or from experience it shall be clear over what period the evidence has been gathered and under what circumstances the material and/or its corrosion protection or preservative treatment has proved satisfactory. Comment shall be made on any hazard that might arise in particular exposure conditions e.g. marine or industrial areas.

6.7.7.2 Identification

The ETA shall contain the following aspects: product description, nature of the profiles, framework, studs, etc., dimensions with tolerances and shape in accordance with clause 5.7.7.2.

7. ASSUMPTIONS AND RECOMMENDATIONS UNDER WHICH THE FITNESS FOR USE OF THE PRODUCTS IS ASSESSED

7.0 General

This chapter sets out the assumptions and recommendations for design, installation and execution, packaging, transport and storage, use, maintenance and repair under which the assessment of the fitness for use according to the ETA-Guideline can be made (only when necessary and in so far as they have a bearing on the assessment or on the products).

7.1 Design of works

See ETA-Guideline, Part 1.

The assessment of the fire protective kits based on boards, slabs or mats shall be assessed under the presumption that the substrate or the supporting frame shall not prejudice any of the ERs of the fire protective kits based on boards used in an assembled system in the works.

The Approval Body shall assess the risks involved and - if deemed necessary - carry out relevant tests or foresee limitations in order for the fire protective kits based on boards to be fit for application in the intended use.

7.2 Packaging, transport and storage

See ETA-Guideline, Part 1.

7.3 Execution of works

See ETA-Guideline, Part 1.

7.4 Maintenance and repair

See ETA-Guideline, Part 1.

SECTION THREE: ATTESTATION OF CONFORMITY

8. ATTESTATION OF CONFORMITY

8.1 EC-decision

The EC-decision is given in Part 1 "General" - Clause 8.1.

8.2 Responsibilities

8.2.0 Introduction

Unless modified or supplemented below, the responsibilities are given in Part 1 "General" - Clause 8.2.

8.2.1 Tasks for the manufacturer

8.2.1.1 Factory production control (FPC)

When products are delivered for incorporation into the production process, verification of conformity with specifications in the ETA shall take place.

The factory production control system for the board kits shall usually include relevant design specifications, including adequate drawings and written instructions sufficiently to verify at least the following items:

- type and quality of all materials and components incorporated in the kits
- positions of components (e.g. mechanical fasteners)
- overall dimensions of kit components
- installation of components and accessories
- markings for correct position and installation in the works, and special handling devices, when relevant
- packaging and transport protection

8.2.2 Tasks for the manufacturer or the approved body

Initial type testing (ITT)

Previous existing tests can be considered for the ETA by the Approval Body, and subsequently for ITT purposes, if they are appropriate for both purposes.

8.2.3 Tasks for the approved body

Assessment of the factory production control system - initial inspection and continuous surveillance.

Surveillance inspections shall be conducted at least twice per year.

8.3 Documentation

The documentation is given in Part 1 "General" - Clause 8.3. Supplementary provisions are given below:

Test plan (as part of FPC)

The validity of the type and frequency of checks/tests conducted during production and on the final product shall be considered. This will include the checks conducted during manufacture on properties that cannot be inspected at a later stage, and for checks on the final product.

The following table shows properties that shall be controlled and minimum frequencies of control, but, for the purposes of FPC, the manufacturer may adopt alternative test methods, provided that they give sufficient assurance of the property controlled.

The tests shall be performed in accordance with the test descriptions referred to, with due consideration that the test equipment and conditions need to be adapted to suit the ETA-applicant's possibilities.

Table 8.1: Properties and minimum frequencies of control⁹

Property	Paragraph, indicating the relevant test method	Threshold value (if any) and tolerances	Minimum frequency of tests ¹⁰	
Boards, slabs and mats:				
Determination of organic content (reaction to fire)	EN 13820	Manufacturer's declaration	1 per week ¹¹	
Determination of dimensional stability at high temperatures (fire resistance)	EN 1094-6 (sample size 100 mm x 100 mm)		1 per week	
Indirect test method ¹²	-		As appropriate	
Water permeability	clause 5.2.3.1		1 per 3 years	
Dimensional stability	clause 5.2.4.2		1 per year	
Thermal resistance	clause 5.2.6.1		1 per 2 years	
Water vapour transmission coefficient	clause 5.2.6.2		1 per 2 years	
Identification	clause 5.2.7.2		Inspection S3 as in ISO 390, 4% AQL	1 per day ¹³ , per dimension
- length, width				1 per day, per thickness
- thickness				1 sample per n-boards
- apparent density			1 sample per n-boards	
Flexural strength	clause 5.2.4.1		1 sample per n-boards	
Mechanical fasteners:				
Identification <ul style="list-style-type: none"> ▪ hardness ▪ dimensions ▪ geometry 	clause 5.3.7.2	Manufacturer's declaration	1 per day	
Adhesives:				
Peel resistance	clause 5.4.4.1.1	Manufacturer's declaration	1 per week	
Shear strength	clause 5.4.4.1.2		1 per day	
Identification <ul style="list-style-type: none"> - Viscosity - Density 	clause 5.4.7.2		1 per day	

⁹ Note 19:

- Usually, some kit components are produced by another manufacturer (supplier) than the ETA-applicant. If this is the case, the test plan can also be carried out by that supplier either under supervision of the ETA-applicant or with the supplier providing appropriate proof that the plan has been followed.
- Only those characteristics relevant for the kit or kit components under ETA, can be part of the test plan.
- If the manufacturer does not have the necessary testing equipment, an external laboratory can be used to perform the necessary tests.
- Where components are used which bear the CE marking, no further assessment of these components is needed for the purposes of this ETAG, provided that the component manufacturer declares all the characteristics required for this ETAG. Components without the CE marking or with product characteristics not covered by the CE-marking, may be considered satisfactory without testing by the kit manufacturer provided that sufficient evidence can be given to show that the above test plan has been followed.

¹⁰ If the ETA-holder has declared "No performance determined" for characteristics, the corresponding parts of the test plan shall not be copied into the ETA.

¹¹ A week represents 5 production days.

¹² Production shall be subjected to (at least) one additional FPC test that is related to fire resistance characteristics and that is especially relevant for the product under consideration. The ETA-holder and the Approval Body shall determine an appropriate frequency.

¹³ A day represents a 24 hour time period in which production is considered to be "normal".

Jointing materials:			
Tensile strength	clause 5.5.7.1.1	Manufacturer's declaration	1 per week
Adhesion/cohesion	clause 5.5.7.1.2		1 per week
Identification ▪ Tensile strength / Viscosity	clause 5.5.7.2		1 per day
Insulation products:			
Thermal resistance	clause 5.6.6.1	Manufacturer's declaration	In accordance with relevant technical specification
Compressive strength	clause 5.6.7.1.1		
Identification	clause 5.6.7.2		
Board kits:			
Pull-through resistance	clause 5.1.4.1.1	Manufacturer's declaration	1 per week
Shear load resistance	clause 5.1.4.1.2		1 per week
Resistance to soft body impact	clause 5.1.4.2.1		1 per year
Resistance to hard body impact	clause 5.1.4.2.2		1 per week
Adhesion	clause 5.1.4.3		1 per week
Identification: ▪ Nature and number of components ▪ Dimensions and geometry	clause 5.1.7.2		1 per day

8.4 CE-marking and information

8.4.1 Introduction

The information regarding the CE-Marking is given in Part 1 "General" - Clause 8.4. Supplementary provisions are given below.

In case the fire protective board product or kit has also been assessed to show conformity with other harmonised technical specifications under the CPD, only one CE Marking will be affixed, but the information accompanying the CE-symbol will combine the provisions foreseen in both harmonised technical specifications (but see clause 8.4.2.2).

8.4.2 Example

8.4.2.1 Example of CE-Marking

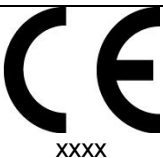
 xxxx
Any Company Rue du Producteur, 50 Country xx xxxx-CPD-xxxx ETA N° XX/XXXX
ETAG XXX, Parts 1 and 4 Fire Protective Board kit Exposure Type : X Intended use : 1,2,3 & 4

"CE"-mark

Number of Notified Body

Name and address of the manufacturer or his representative established in the EEA and of the plant where the product was manufactured

Two last digits of year of affixing CE Marking
Number of EC certificate of conformity
ETA Number

ETAG Reference

Use category(-ies) related to weather exposure (see clause 2.2.2)

Use category (-ies) related to intended use (see clause 2.2.4)

ETAG 018-4 (2011)

8.4.2.2 Location of CE-Marking

The CE-Marking shall be affixed on the accompanying documents.

In case the fire protective board product or kit has also been assessed to show conformity with other harmonised technical specifications under the CPD (ETA or EN), the location of the CE Marking shall be in conformity with both documents.

Note 19: In practice, this might mean that if the other harmonised technical specification requires affixing the CE Marking on the product itself, that there will be a CE Marking on the product and on the accompanying document s.

SECTION FOUR

9. THE ETA CONTENT

9.1 The ETA-content

The ETA-content is given in Part 1 "General" – clause 9. In addition, it shall contain a description of the tested assembly and the product characteristics of all the products or kit components that were necessary to install the assembly in the fire resistance test. Those product characteristics shall be considered as minimum product requirements to obtain the fire resistance classification.

This applies to the fire protective boards, but also to e.g. supporting frame, adhesives, fixing system or joint material, used in the assembly that was tested, even if they are not part of the kit.

The ETA shall specify the Working life and the use categories related to intended use and weather exposure (see clause 2.2).

The ETA shall specify the results of the assessment given in chapter 6. Every declaration in the ETA represents a favourable assessment of the component's performance, taking into account the intended use, made under the responsibility of the Approval Body.

Information about kit, products or kit component performance shall only be declared for those characteristics in chapters 5 and 6 of this Part of the ETA-Guideline that are relevant for the product or kit component under consideration and as far as relevant for the fitness for the intended use(-s). Characteristics for which the NPD-option is not allowed (see this ETA-Guideline, Part 1, table 6.1) shall always be declared.

When the product(-s) have been assessed through assembly testing, the ETA shall clearly specify the tested assembly (or assemblies), identifying the components used (e.g. boards, framework or mechanical fasteners. by cross reference within the ETA) and their quantity and configuration and test conditions.

The Approval Body's accepted extended application (if any), based on those test results, shall be specified separately from test results, referring to the basis on which the extended application was accepted (e.g. calculations).

9.2 Additional information

The additional information is given in Part 1 "General" – clause 9

9.3 Exceptions

There are no exceptions to the content information mentioned in Part 1 "General" – clause 9

ANNEX A: List of reference documents

Where reference is made to a specific clause of a document, the document is dated. Approval Bodies however may use more recent versions if the content of the clause is unchanged.

EN 300	Oriented strand boards (OSB) - Definitions, classification and specifications
EN 318	Fibreboards - Determination of dimensional changes associated with changes in relative humidity
EN 319	Particleboards and fibreboards - Determination of tensile strength perpendicular to the plane of the board
EN 542	Adhesives - Determination of density
EN 573-3	Aluminium and aluminium alloys - Chemical composition and form of wrought products – Part 3: Chemical composition
EN 771	Specification for masonry units Part 1: Clay masonry units Part 2: Calcium silicate masonry units Part 3: Aggregate concrete masonry units (dense and light-weight aggregates) Part 4: Autoclaved aerated concrete masonry units Part 5: Manufactured stone masonry units Part 6: Natural stone masonry units
EN 789	Timber structures - Test methods - Determination of mechanical properties of wood-based panels
EN 822	Thermal insulating products for building applications - Determination of length and width
EN 823	Thermal insulating products for building applications - Determination of thickness
EN 824	Thermal insulating products for building applications - Determination of squareness
EN 826	Thermal insulating products for building applications - Determination of compressive behaviour
EN 923	Adhesives - Terms and definitions
EN 993-14	Methods of testing dense shaped refractory products - Part 14: Determination of thermal conductivity by the hot-wire (cross-array) method
EN 998	Specification for mortar for masonry Part 1: Rendering and plastering mortar with inorganic binding agents Part 2: Masonry mortar
EN 1015	Methods of test for mortar for masonry Part 11: Determination of flexural and compressive strength of hardened mortar Part 12: Determination of adhesive strength of hardened rendering and plastering mortars on substrates
EN 1094-6	Insulating refractory products - Determination of permanent change in dimensions of shaped products on heating
EN 1239	Adhesives - Freeze/thaw stability
EN 1364-2	Fire resistance tests for non-loadbearing elements - Part 2: Ceilings
EN 1372	Adhesives - Test method for adhesives for floor and wall coverings - Peel test
EN 1373	Adhesives - Test method for adhesives for floor and wall coverings - Shear test
EN 1396	Aluminium and aluminium alloys - Coil coated sheet and strip for general applications – Specifications
EN 1507	Ventilation for buildings – Ductwork – Requirements for testing strength and leakage of rectangular sheet metal air ducts.
EN 1602	Thermal insulating products for building applications - Determination of the apparent density

EN 1603	Thermal insulating products for building applications - Determination of dimensional stability under constant normal laboratory conditions (23°C/50% relative humidity)
EN 1604	Thermal insulating products for building applications - Determination of dimensional stability under specified temperature and humidity conditions
EN 1607	Thermal insulating products for building applications - Determination of tensile strength perpendicular to faces
EN 1608	Thermal insulating products for building applications - Determination of tensile strength parallel to faces
EN 1609	Thermal insulating products for building applications - Determination of short term water absorption by partial immersion
EN 1766	Products and systems for the protection and repair of concrete structures - Test methods - Reference concretes for testing
EN 1912	Structural timber - Strength classes - Assignment of visual grades and species
EN 1990:2002	Eurocode - Basis of structural design
EN 1993 series	Eurocode 3 - Design of steel structures
EN 1995 series	Eurocode 5 - Design of timber structures
EN 1999 series	Eurocode 9 - Design of aluminium structures
EN 10002-1	Tensile testing of metallic materials - Method of test at ambient temperature
EN 10020	Definition and classification of grades of steel
EN 10088	Stainless steels - List of stainless steels
EN 10142	Continuously hot-dip zinc coated low carbon steels strip and sheet for cold forming - Technical delivery conditions
EN 10147	Continuously hot-dip zinc coated structural steels strip and sheet - Technical delivery conditions
EN 10152	Electrolytically zinc coated cold rolled steel flat products - Technical delivery conditions
EN 10169-1	Continuously organic coated (coil coated) steel flat products – Part 1: General information (definitions, materials, tolerances, test methods)
EN 10214	Continuously hot-dip zinc-aluminium (ZA) coated steel strip and sheet - Technical delivery conditions
EN 10215	Continuously hot-dip aluminium-zinc (AZ) coated steel strip and sheet - Technical delivery conditions
EN 10327	Continuously hot-dip coated strip and sheet of low carbon steels for cold forming - Technical delivery conditions
EN 12086	Thermal insulating products for building applications - Determination of water vapour transmission coefficient
EN 12089	Thermal insulating products for building applications - Determination of bending behaviour
EN 12092	Adhesives - Determination of viscosity
EN 12101	Smoke and heat control systems
	Part 1: Specification for smoke barriers
	Part 2: Specification for natural smoke and heat exhaust ventilators
	Part 3: Specification for powered smoke and heat exhaust ventilators
	Part 4: Installed SHEVS systems for smoke and heat ventilation
CEN/TR 12101-5	Smoke and heat control systems
	Part 5: Guidelines on functional recommendations and calculation methods for smoke and heat exhaust ventilation systems
EN 12101	Smoke and heat control systems
	Part 6: Specifications for pressure differential systems – Kits
	Part 7: Smoke ducts
	Part 8: Smoke control dampers
	Part 9: Control panels and emergency control panels
	Part 10: Power supplies

EN 12365-1	Building hardware - Gasket and weatherstripping for doors, windows, shutters and curtain walling - Part 1: Performance requirements and classification.
EN 12412-2	Thermal performance of windows, doors and shutters - Determination of thermal transmittance by hot box method – Part 2: Frames
EN 12467:2005	Fibre-cement flat sheets - Product specifications and test methods
EN 12664	Thermal performance of building materials and products - Determination of thermal resistance by means of guarded hot plate and heat flow meter methods - Dry and moist products of medium and low thermal resistance
EN 12667	Thermal performance of building materials and products - Determination of thermal resistance by means of guarded hot plate and heat flow meter methods - Products of high and medium thermal resistance
EN 12939	Building materials - Determination of thermal resistance by means of guarded hot plate and heat flow meter methods - Thick products of high and medium thermal resistance
EN 13162	Thermal insulation products for buildings - Factory made products of Mineral Wool (MW) – Specification
EN 13238	Reaction to fire tests for building products - Conditioning procedures and general rules for selection of substrates
EN 13381	Test methods for determining the contribution to the fire resistance of structural members - Part 1: Horizontal protective membranes
EN 13403	Ventilation for buildings – Non-metallic ducts – Ductwork made from insulation ductboards
EN 13467	Thermal insulating products for building equipment and industrial installations - Determination of dimensions, squareness and linearity of preformed pipe insulation
EN 13501	Fire classification of construction products and building elements Part 1: Classification using test data from reaction to fire tests Part 2: Classification using test data from fire resistance tests Part 3: Classification using data from fire resistance tests on components of normal building service installations Part 4: Classification using test data from fire resistance tests on smoke control systems
EN 13820	Thermal insulating materials for building applications - Determination of organic content
EN 13823	Reaction to fire tests for building products - Building products excluding floorings exposed to the thermal attack by a single burning item
EN 13964:2004	Suspended ceilings – Requirements and test methods
EN 24624	Paints and varnishes - Pull-off test
EN ISO 527-1	Plastics - Determination of tensile properties - General principles
EN ISO 527-2	Plastics - Determination of tensile properties - Test conditions for moulding and extrusion plastics
EN ISO 3506-1	Mechanical properties of corrosion-resistant stainless-steel fasteners Part 1: Bolts, screws and studs Part 2: Nuts Part 3: Set screws and similar fasteners not under tensile stress
EN ISO 8339: 2005	Building construction - Sealants - Determination of tensile properties (Extension to break)
EN ISO 9047:2001	Building construction - Jointing products - Determination of adhesion/cohesion properties of sealants at variable temperatures (+AC:2009)
EN ISO 10077-2	Thermal performance of windows, doors and shutters - Calculation of thermal transmittance Part 2: Numerical method for frames
EN ISO 10456	Building materials and products - Hygrothermal properties -Tabulated design values and procedures for determining declared and design thermal values
EN ISO 10590:2005	Building construction - Sealants - Determination of tensile properties of sealants at maintained extension after immersion in water
EN ISO 11431:2002	Building construction - Jointing products - Determination of adhesion/cohesion properties of sealants after exposure to heat, water and artificial light through glass

EN ISO 11600:2000	Building construction - Jointing products - Classification and requirements for sealants
EN ISO 12572:1997	Hygrothermal performance of building materials and products - Determination of water vapour transmission properties
EN ISO 12944-3	Paints and varnishes - Corrosion protection of steel structures by protective paint systems - Design considerations
EN ISO 13787	Thermal insulation products for building equipment and industrial installations – Determination of declared thermal conductivity
EN ISO 13788	Hygrothermal performance of building components and building elements - Internal surface temperature to avoid critical surface humidity and interstitial condensation - Calculation methods
ISO 390	Products in fibre-reinforced cement - Sampling and inspection
ISO 5922	Malleable cast iron
prEN 1015-20	Methods of test for mortar for masonry - Determination of durability of hardened masonry mortars (with cement comprising less than or equal to 50% of the total binder mass)
ISO/DIS 8413	Performance Standards in Building - Partitions made from Components - Tests for Ability to withstand Suspended Static Loads
EOTA TR001:2003	Determination of impact resistance of panels and panel assemblies
EOTA TR024	Characterisation, aspects of durability and factory production control for reactive materials, components and products

ANNEX B:

EN 13823: Reaction to fire tests for building products - Building products excluding floorings exposed to the thermal attack by a single burning item Mounting and fixing provisions

B.1 Terminology

Extended application:

The outcome of a process (involving the application of defined rules that may incorporate calculation procedures) that predicts, for a variation of a product property and/or its intended end use application(s), a test result on the basis of one or more test results to the same test standard

B.2 Mounting & Fixing in accordance with EN 13823

Note 20: These mounting and fixing provisions can only be used to determine the reaction to fire class of boards, slabs and mats. The procedure for testing tiles, if they are not Class 1, is to be agreed between the applicant and the Approval Body.

B.2.1 Dimensions of the test rig

The test rig consists of a corner, with a long (1,0 m) and a short wing (0,5 m). The long wing consists of 2 boards, with one vertical and one horizontal board-to-board joint in between. All boards shall be tested vertically. The dimensions of the specimens shall be:

	Assembly dimensions (mm – nominally)	
	Length	Height
Short wing	500	1500
Long wing	200 + t	1500
	800	1500

Where t = thickness of the board
Note: Given that the thickness is relatively small, test performed with the length of the long wing including the thickness will be accepted as well.

B.2.2 Test specimen

Fire protective boards shall be mounted and fixed according to EN 13823 and as specified below.

The boards used in the test assembly shall always include all facings and/or coatings that are applied to the product, as it is placed onto the market. Each facing and/or coating type requires new tests.

Test results from boards with maximum facing or coating thickness are valid for thinner coatings as well (for intumescent coatings the same applies).

Influences of different colours of facings or coatings can be determined by performing SBI tests on a light and on a dark colour. If the colour does not lead to a change in class or sub-class (smoke and droplets) then the full scale SBI is only conducted on one colour.

The assembly, including the joint detail and corner detail, shall be in accordance with end use conditions, as specified by the ETA-applicant.

Due to the specific requirements of the test standard, it may not be possible to mount the boards as usually specified by the ETA-applicant. In that case, the mounting arrangement shall be as similar as possible and agreed between ETA-applicant and Approval Body.

The type and dimensions of materials and products used, the dimensions and mechanical fasteners' location, etc shall be recorded in the test report.

B.2.3 Mounting and fixing of the test assembly

B.2.3.1 Assemblies with framework/studs (see figures B.1 to B.5)

The boards shall be fixed on a (structural) framework, using the fixing system and, if relevant, the jointing material, profile, etc., as specified by the ETA-applicant, representing the tight joint, achieved in end use (see figures B.1 to B.5).

In accordance with EN 13823, the minimum distance between the backing boards and the fire protective board samples shall be 40 mm, using spacer bars at top and bottom. The frame between backing board and specimen shall be open at the sides to allow ventilation into the gap.

Note 21: The assembly may be prepared and fixed together away from the test chamber. The complete assembly can then be transported to the chamber.

The boards are mounted on a framework made out of timber, (40 ± 1) mm by (40 ± 1) mm for vertical members, (20 ± 1) mm by (40 ± 1) mm for horizontal members. Test results for timber framework also apply for metal framework. In case the ETA-applicant claims better performance with metal studs or in case the ETA-applicant does not use timber framework, the test can also be performed with the most onerous type (related to dimensions and thickness of the profiles) of metal framework. If larger filling material thicknesses are used (see below), then the stud dimensions need to be increased accordingly.

If the kit contains filling material for introduction behind the fire protective board, such as mineral wool, the gap between backing board and specimen shall be filled completely, to establish contact between the insulation and the fire protective board.

The type of filling material shall meet the ETA-applicant's specifications, but a (50 ± 5) mm thick mineral wool slab, density (35 ± 10) kg/m³, Euroclass A1/A2-s1,d0 (organic binder < 5 %; melting point > 1000 °C), may be used as a typically used filling material. The mineral wool is fixed on the substrate, in accordance with ETA-applicant's specifications.

To assess the filling material's influence, tests can be necessary on the smallest and largest thicknesses and the smallest and largest densities (these may vary between 20 kg/m³ and 190 kg/m³).

If any other filling material is used, this has to be considered and tested.

The cut edge of the short wing board shall be placed against the long wing assembly to form an internal corner. On the long wing, a vertical joint is situated 200 mm from the internal corner and a horizontal joint 500 mm from the bottom.

These joints shall be constructed as in practice (usually, these are butt joints), but these are normally not larger than 3 mm (dimension x in the figures B.1 to B.5). The test result is valid only for joints with the width used in the test or smaller joints. In accordance with the ETA-applicant's end use specifications, the joints may be filled and/or strips may be foreseen on the framework.

The two wings shall then be secured at 90° to each other, using the corner finishing products (jointing material, profile, etc.) in accordance with end use conditions, as specified by the ETA-applicant.

If the ETA-applicant does not normally use a particular mechanical fastener, rivets, clips or screw fixings meeting the ETA-applicant's minimum performance criteria shall be used. The type of mechanical fastener used during the tests shall be agreed between ETA-applicant and Approval Body.

In any other case, the ETA-applicant's mechanical fasteners shall be used.

The fastening pattern and number of mechanical fasteners shall correspond to the kit or component manufacturer's specifications. They shall be reported in the test report.

B.2.3.2 Assemblies without framework (see figures B.3 to B.5)

These tests shall be used for boards, slabs and mats that are mechanically fixed or adhered onto the substrate, without the use of studs or framework.

In this case, the boards, slabs or mats shall be adhered with the adhesive in accordance with ETA-applicant's specifications. The quantity and pattern of adhesive shall correspond to the kit or component manufacturer's specifications. This information shall be reported in the test report. In figure B.5, the boards and studs are not included. One or more of the substrates defined in EN 13238 shall be used.

Note 22: If the ETA-applicant chooses to perform the test using alternative substrates, he will not be able to benefit from the direct application rules provided in EN 13238.

If the ETA-applicant does not normally use a particular mechanical fasteners, rivets, clips or screw fixings meeting the ETA-applicant's minimum performance criteria shall be used. In that case, the type of mechanical fasteners used during the tests shall be agreed between ETA-applicant and Approval Body.

In any other case, the ETA-applicant's mechanical fasteners shall be used.

The fastening pattern and number of mechanical fasteners to be used is given on the figures B.3 and B.4.

B.3 Figures B.1 to B.5 Tolerances on dimensions are ± 1 mm.

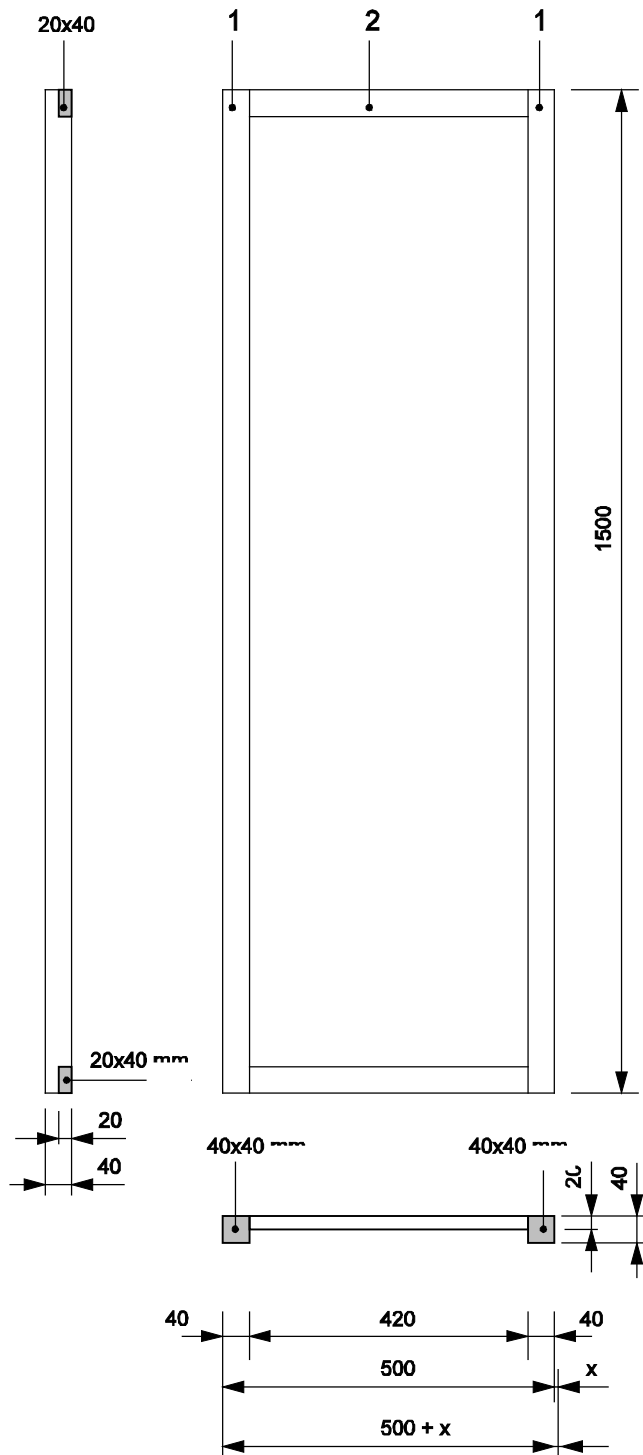

Key
 1 Vertical frame members
 2 Horizontal frame members
 x Joint width

Dimensions in mm

Figure B.1: Framework for short wing in EN 13823

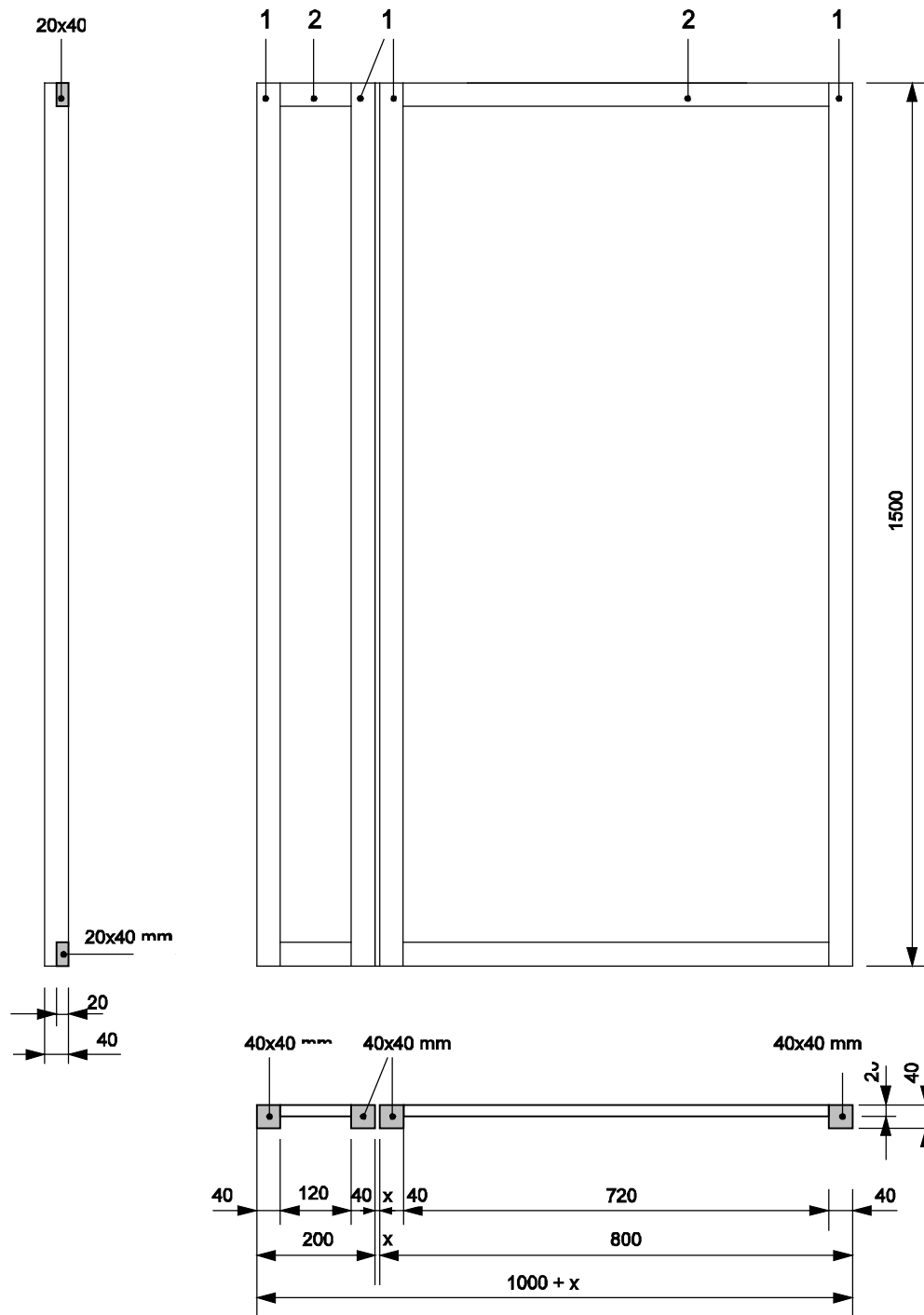

Key

- 1 Vertical frame members
- 2 Horizontal frame members
- x Joint width

Dimensions in mm

Figure B.2: Framework for long wing in EN 13823

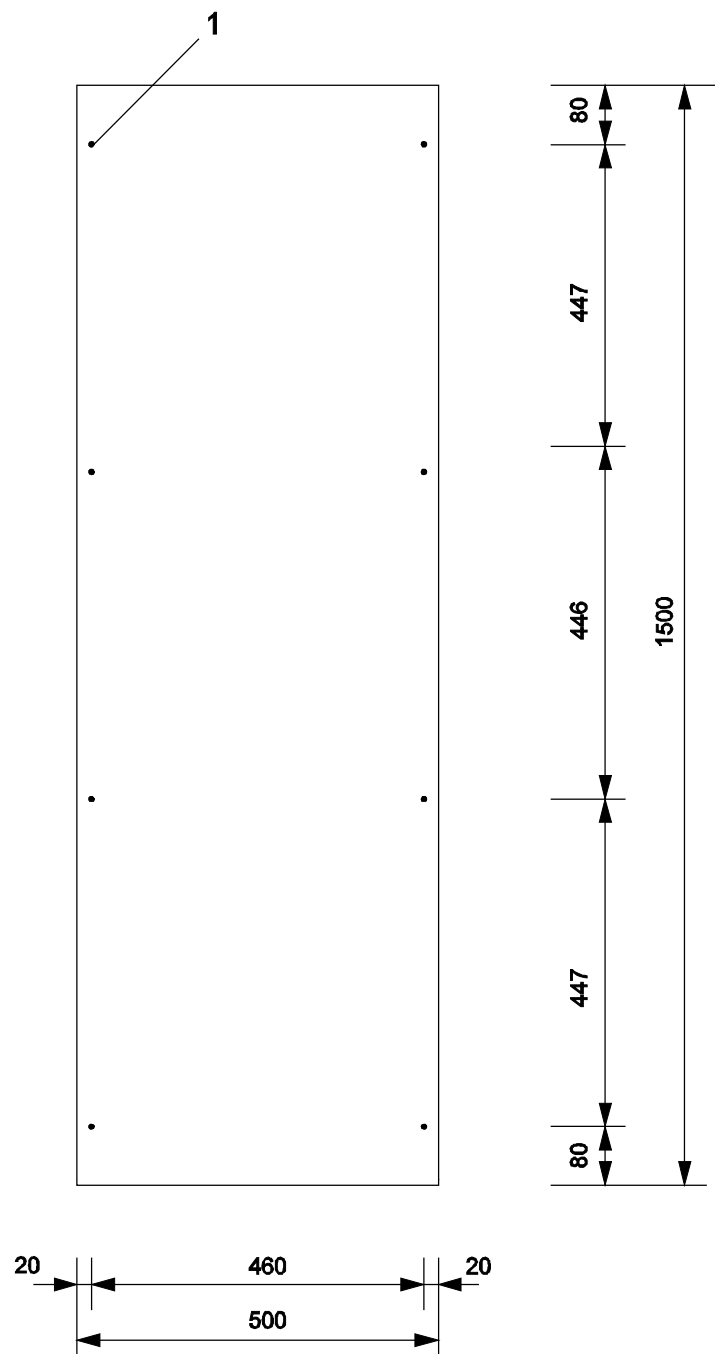

Key
 1 Mechanical fastener

Dimensions in mm

Figure B.3: Fixing of boards, slabs and mats for short wing in EN 13823

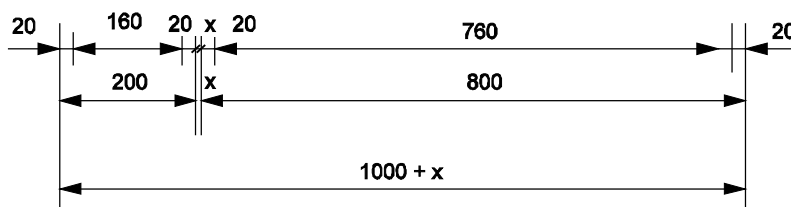
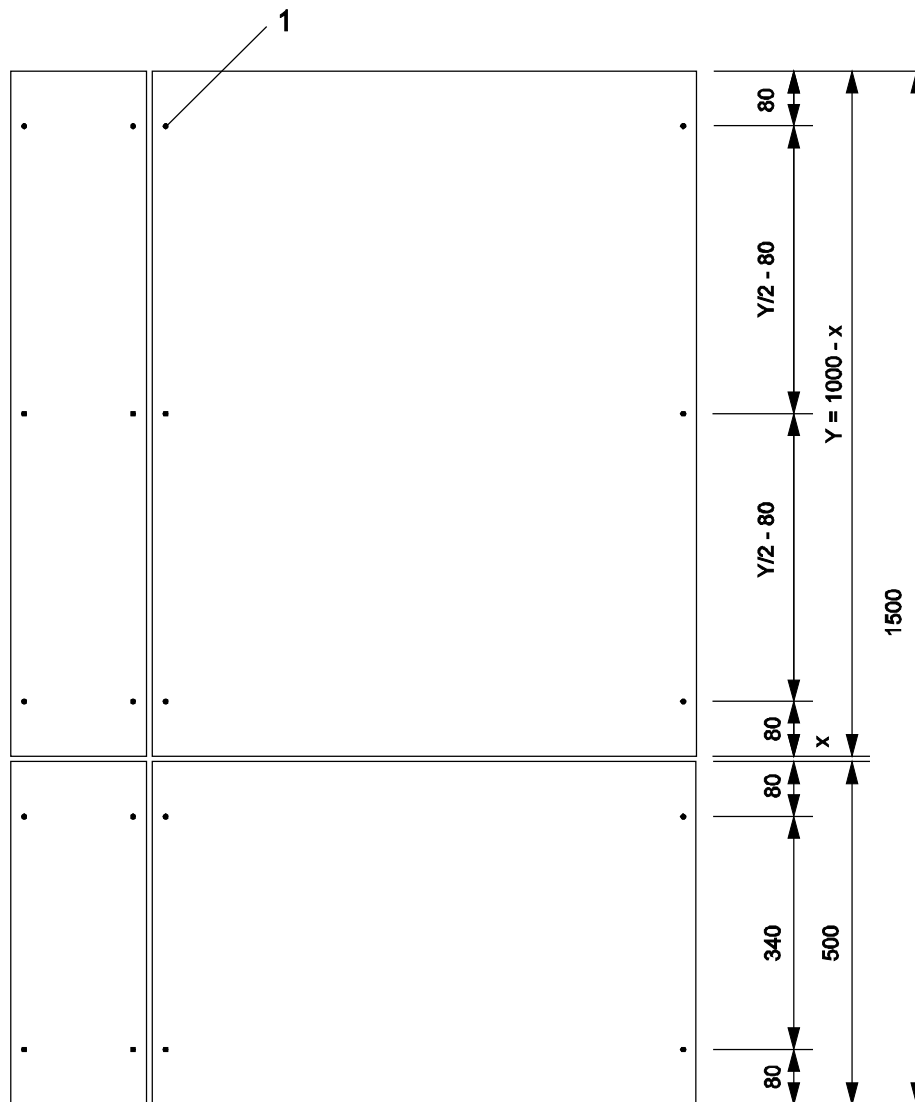

Key
 1 Mechanical fastener
 x Joint width

Dimension in mm

Figure B.4: Fixing of boards, slabs and mats for long wing in EN 13823

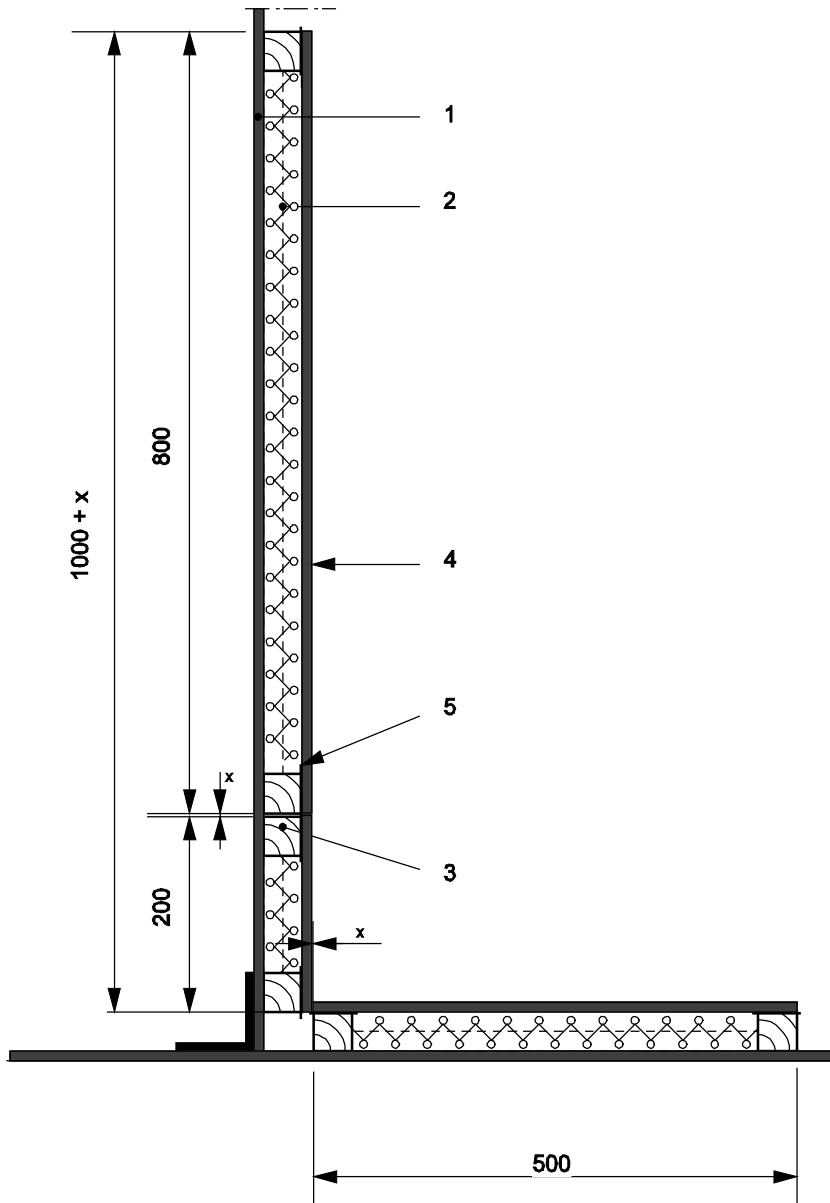

- Key
- 1 Backing board
 - 2 Insulation
 - 3 Vertical member
 - 4 Board
 - 5 Joint material
 - x Joint width

Dimensions in mm

Figure B.5: Schematic Mounting and fixing arrangement in EN 13823

ANNEX C: Assessment for Composite boards

C.1 General

Assessing and judging the fitness of boards, consisting of two or more layers of materials, requires additional assessment, which can be regarded as serviceability assessment, and which depends on the nature of the materials involved and the bonding method. The assessment is presented below. However, depending on the nature of the materials involved and the bonding method, further assessment might be deemed necessary by the Approval Body.

C.2 Reactive layers

If the board contains reactive layers or finishings, these reactive materials shall be assessed and judged in accordance with EOTA Technical report 024.

C.3 Tensile strength perpendicular to the board faces

The tensile strength perpendicular to the board faces shall be determined and declared in accordance with EN 1607.

C.4 Compatibility

The compatibility of the materials involved, taking into account the intended use, shall be assessed. The Approval Body shall indicate which assessment took place and shall declare limitations of intended use, if relevant.

C.5 Assessment and judgment

The Approval Body shall assess and judge the fitness for use of the product or kit component for each characteristic that was verified. Every declaration in the ETA represents a favourable assessment of the component's performance, taking into account the intended use, made under the responsibility of the Approval Body.

ANNEX D: Freeze/thaw conditioning for use category Y

D.1. Principle

This annex describes the conditions and procedures which need to be observed when conditioning fire protective boards of type Y in condensation water alternating atmospheres.

The tests are designed to establish any defects in the protection of the test specimen against the combined influence of condensation and freeze/thaw.

D.2. Cycles

The test specimen will be subjected to 25 cycles. Each cycle has a duration of 24 hours and is as follows:

Time (min, \pm 5 min.)	Temperature ($^{\circ}$ C, \pm 2 $^{\circ}$ C)	Relative humidity (%, \pm 5%)
240	23	95
120	Decrease to -10	Uncontrolled, but climate chamber remains shut
960	-10	
120	Increase to 23	

D.3. Apparatus

The material of the inner walls of the vapour-tight climatic chamber shall be corrosion-resistant and shall not affect the test panels. The climatic chamber is usually equipped with a floor trough which acts as the receptacle for the water.

The test chamber shall be tempered by heating the water in the floor trough. If the quantity of heat introduced via the water is insufficient to raise the air temperature in the test room to the required level, then additional heating can be employed.

Note 23: The heating-up time will depend on the nature and quantity of the test panels, and also on the ratio of the water surface of the floor trough to the wall surface of the test chamber, and on the water temperature.

The climatic chamber shall be provided with a suitable door or other aperture capable of being closed, which allows the test chamber to be charged with test panels and to be ventilated.

Note 24: An example of a condensation water climatic testing device is given in Figure D.1.

Climatic testing devices not equipped with water-filled floor troughs shall be fitted out in such a way that an adequate formation of condensation water on the test panels is achieved.

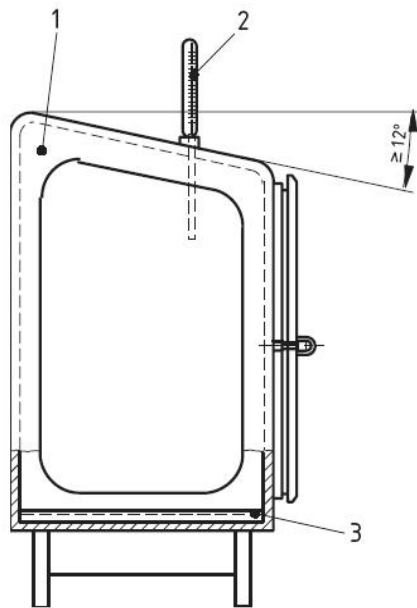

Key¹⁴
 1) pressure relief valve
 2) temperature measuring device
 3) floor trough filled with water

Figure D.1 - Example of a condensation water climatic testing device

D.4. Procedure

D.4.1 Filling the floor trough

The floor trough shall be filled with water in such a way that a depth of water of at least 10 mm is present at all times during operation.

Note 25: It is recommended that distilled or de-ionized water is used to avoid calcification of the apparatus.

D.4.2 Test panels

Only test specimens that do not mutually influence one another shall be tested together at any one time.

D.4.3 Arrangement of the test panels

The test panels shall be vertically arranged in the chamber in such a way that they are not in close contact with each other and that they are able to adequately radiate heat.

The following minimum spacings shall be observed:

- distance from the walls: not less than 100 mm
- distance of the bottom edge of the test panel from the surface of the water not less than 200 mm
- spacing between adjoining test panels: not less than 20 mm

Precautions shall be taken to ensure that no condensation water is allowed to drip onto the test panels from the walls or ceiling of the test chamber, nor from other test panels.

¹⁴ The apparatus is given as an example. Any equipment achieving the same conditions is acceptable.

D.4.4 Test sequence

D.4.4.1 Start-up

Place the test panels in position, close the climatic chamber and switch on the heating for the floor trough water or for the climatic testing device. Heat the chamber to $(23 \pm 2) ^\circ\text{C}$, attaining this temperature within 30 min. Condensation water shall be formed on the test panels.

D.4.4.2 Cycles

4 hours after commencement of the start-up phase (see above), switch off the heating and terminate the condensation process (first test period). Cool the climatic chamber to $(-10 \pm 2) ^\circ\text{C}$, without opening the cabinet. The cooling down period shall be finalised within 2 hours.

After a further 16 hours, switch on the heating again and heat, within 2 hours, until $(23 \pm 2) ^\circ\text{C}$ and $(95 \pm 5) \%$. Commence a new cycle. Check and top up if necessary the water level in the floor trough.

Test specimen shall not be removed from the climatic chamber before end of all the cycles.