



European Organisation for Technical Approvals
Europäische Organisation für Technische Zulassungen
Organisation Européenne pour l'Agrément Technique

ETAG 021

Edition October 2005

GUIDELINE FOR EUROPEAN TECHNICAL APPROVAL

OF

COLD STORAGE PREMISES KITS
Part 2: COLD STORAGE BUILDING
ENVELOPE and BUILDING KITS

Kunstlaan 40, avenue des Arts
B-1040 Brussels

TABLE OF CONTENTS

TABLE OF CONTENTS	2
FOREWORD	4
Section One: INTRODUCTION	8
1. Preliminaries	8
1.1 Legal basis	8
1.2 Status of ETA-Guidelines	8
2. Scope	10
2.1 Scope	10
2.2 Use categories, product families, kits and systems	11
2.3 Assumptions	14
3. Terminology	17
3.1 Common terminology and abbreviations	17
3.2 Specific terminology and abbreviations related to the products and their intended use covered by this Guideline	17
Section Two: GUIDANCE FOR THE ASSESSMENT OF THE FITNESS FOR USE	18
Introductory Notes	18
4. Requirements for works and their relationship to the product characteristics	20
4.1 Mechanical Resistance and Stability	23
4.2 Safety in case of Fire	23
4.3 Hygiene, Health and the Environment	24
4.4 Safety in Use	25
4.5 Protection against Noise	27
4.6 Energy Economy and Heat Retention	28
4.7 Aspects of Durability, Serviceability and Identification	28
5. Methods of Verification	30
5.1 Verification Methods Relevant for the Kit / Assembled System	32
5.2 Verification Methods Relevant for Components: Composite Panels	40
5.3 Verification Methods relevant for Components: Doors, gates and Windows, roof windows and rooflights	45
5.4 Verification Methods relevant for Components: Fixing Systems, Sealants, Gaskets and Building Hardware	49
5.5 Verification methods for Components: Profiles, framework, studs, etc.	55
6. Assessing and judging of the fitness for use of products for an intended use	58
6.1 Assessing and judging of the fitness for use of the Kit / Assembled System	60
6.2 Assessing and judging of the fitness for use of components of the kit: Composite Panels	65
6.3 Assessing and judging of the fitness for use of components of the kit: Doors, gates and Windows, roof windows and rooflights	70
6.4 Assessing and judging of the fitness for use of components of the kit: Fixing Systems, Sealants, Gaskets and Building Hardware	73
6.5 Assessing and judging of the fitness for use of components of the kit: Profiles, framework, studs, etc.	77
7. Assumptions and Recommendations under which the Fitness for Use of the Products is Assessed	79
7.1 Design of works	79
7.2 Packaging, transport and storage	83
7.3 Execution of works	83
7.4 Maintenance, repair and cleaning	84
7.5 Recommendations related to the internal and external environment of cold storage buildings	85
Section Three: ATTESTATION OF CONFORMITY	89
8. Attestation of Conformity	89
8.1 EC decision	89
8.2 Responsibilities	89
8.3 Documentation	93
8.4 CE-marking and information	96

Section Four: ETA CONTENT	99
9 The ETA-Content	99
ANNEX A Common terminology and abbreviations	100
ANNEX B Specific terminology and abbreviations related to the products and their intended use covered by this guideline	101
ANNEX C List of reference documents	105

FOREWORD

Background

This Guideline has been drawn up by the EOTA Working Group 02.05/02 - Cold storage building envelope and building kits.

The WG consisted of members from the following 6 EU-countries: Belgium, France, Finland, Germany, Italy and the United Kingdom. Poland was an observing country. The European Profiles and Panels Producers Federation (EPPF) became industrial representative after EOTA Technical Board endorsement of its request in May 2001.

The Guideline sets out the performance requirements, the verification methods used to examine the various aspects of performance, the assessment criteria used to judge the performance for the intended use and the presumed conditions for the design and execution of the cold storage building envelope and building kits in the works.

The general assessment approach of the ETA-Guideline is based on relevant existing knowledge and testing experience and the draft ETA-Guideline Part 1 for Cold storage room kits. Assessment criteria were chosen based on an analysis of technical aspects related to the performance of cold storage building envelope and building kits made of traditional materials. The assessment of the panels which are main components of cold storage building envelopes and buildings, i.e. composite panels with insulating cores, is primarily based on the draft harmonised technical specifications ETA-Guideline 016 "Self supporting light weight composite panels" or prEN 14509 "Double metal faced insulated sandwich panels".

This ETA-Guideline takes into account the construction product related provisions of the EC Foodstuff directive (93/43/EEC) and the EC Food Contact Materials directives (89/109/EEC and the related specific directives), in as far as they present barriers to trade for cold storage building envelope and building kits, at the moment of writing of this ETA-Guideline. This means that the ETA-Guideline is subject to modification should additional requirements apply in EEA Member States.

This ETA-Guideline supports the EC *"farm to table" approach to food safety*, referred to in the Commission's White paper on food safety, which is an holistic approach embracing all elements, which may have an impact on the safety of food, at every level of the food chain and the proposed (amended) EC regulations with regard to food safety and food contact materials (COM(2003) 33 final and COM(2003) 689 final).

Notes:

- ❑ Users should be aware that the provisions in this ETA-Guideline, related to food safety, are to be considered as guidance to good hygiene practice. The Guideline does not in any way diminish, modify or supplement legislation in this area, nor constitute legal guidance. Individual food businesses are responsible for checking how the relevant EC Regulations and Directives apply in practice to them. The ETA-Guideline covers only that part of the Regulation's and Directive's requirements, related to the construction kit (product).
- ❑ If taken into account, kit and component specifications and recommendations for their use as specified in this ETA-Guideline, will contribute to cleanliness and food safety, by reducing the task of regular maintenance and cleaning. However, it should be understood that sanitation and cleanliness requires training and practice by the user of the assembled kit.

For power operated cold storage building envelope and building doors and gates, the ETA-Guideline introduces compliance criteria for the Electromagnetic Compatibility (EMC) Directive 89/336/EEC and the Machinery Directive 98/37/EC, amended by Directive 98/79/EC.

Where relevant, national technical specifications have been discussed and taken into account in developing appropriate test and calculation methods for assessing the cold storage building envelope and building kits.

Reference documents

Reference documents are referred to within the body of the ETA-Guideline and are subject to the specific conditions described therein.

The **list of reference** documents (mentioning the year of issue) for this ETA-Guideline is given in Annex C. When additional parts for this ETA-Guideline are written afterwards, they may comprise modifications to the list of reference documents applicable to that part.

Updating conditions of reference documents

The edition of a reference document given in this list is that which has been adopted by EOTA for its specific use.

When a new edition becomes available, this supersedes the edition mentioned in the list only when EOTA has verified or re-established (possibly with appropriate linkage) its compatibility with the guideline.

EOTA Technical Reports go into detail in some aspects and as such are not part of the ETA-Guideline, but express the common understanding of existing knowledge and experience of the EOTA-bodies at that moment. When knowledge and experience is developing, especially through approval work, these reports can be amended and supplemented.

EOTA Comprehension Documents permanently take on board all useful information on the general understanding of this ETA-Guideline as developed when delivering ETA's in consensus by the EOTA members. Readers and users of this ETA-Guideline are advised to check the current status of these documents with an EOTA-member.

EOTA may need to make alterations/corrections to the ETA-Guideline during its life. These changes will be incorporated into the official version on the EOTA-website www.eota.be and the actions catalogued and dated in the associated progress file.

Readers and users of this ETA-Guideline are advised to check the current status of the content of this document with that on the EOTA-website. The front cover will indicate if and when amendment has taken place.

Guidance for ETA-applicants

Construction products shall comply with the CPD when they are put on the European Economic Area (EEA) market. Putting into service, which takes place at the moment of first use within the EEA by the end user, is considered in some other "New approach" directives, but not the CPD.

Placing on the market as referred to in the CPD is the initial action of making a product available for the first time on the EEA market, with a view to distribution or use in the EEA. Making available can be either for payment or free of charge. This is considered to take place when a product is transferred from the stage of manufacture with the intention of distribution or use on the EEA market. Moreover, the concept of placing on the market refers to each individual product, not to a type of product, and whether it was manufactured as an individual unit or in series.

This ETA-Guideline covers cold storage building and building envelope kits meeting the specification of the scope (see clause 2.1). The concept of the term "kit" is explained in EC Guidance paper C.

ETAs based on this ETA-Guideline will cover kits with identified intended use(-s) (e.g. unpackaged food storage). During the approval issuing process, the approval bodies will assess whether the kit design, the components and the installation and maintenance foreseen by the ETA-applicant lead to an overall favourable assessment of the kit for that/those intended use(-s). Kits that are in conformity with an ETA can be CE Marked, all others cannot.

In practice, this might mean that in case a cold storage building or building envelope kit

manufacturer wants to put on the market a cold storage building and building envelope kit for another intended use and/or using (an)other component(-s) than foreseen in the ETA, his ETA needs to be revised or a new ETA needs to be issued, before he can CE Mark that kit. It is therefore necessary for manufacturers to envisage a broad intended use and to incorporate components that are being used in practice at the time of applying for an ETA.

The ETA-Guideline can be used to issue ETAs for continuously and discontinuously (intermittently) produced kits. Where kits are being adapted (e.g. changes to the dimensions of panels, additional windows, etc.) to project related requirements, but based on the same design, ETA-applicants need to ensure that all necessary variations have been considered in the ETA. Obviously, FPC requirements in the ETA shall be adapted to suit the type of production.

Components of cold storage buildings or building envelopes put on the EEA market separately are not covered by this ETA-Guideline. Such products (e.g. sandwich panels, profiles, sealants, gaskets), even if they are explicitly intended to be used as a part of a cold storage building or building envelope, will be covered by other harmonized technical specifications¹.

Contractors that assemble components of cold storage buildings or building envelopes put on the EEA market separately are not obliged to apply for an ETA, because they do not place a product on the market. However, they may apply for one. Their advantage may be that by obtaining an ETA, they dispose of a favourable assessment of the kit, i.e. the combination of components, for the intended use, whereas when they assemble components of cold storage buildings or building envelopes put on the EEA market separately, only the fitness for use of the separate components has been assessed through the individual CE Markings. The fitness for use of the combination of those components will need to be demonstrated on site.

It is important to note that some cold storage building or building envelope kits might incorporate components that are covered by other EU directives (e.g. power operated doors or gates, which are covered by the Low Voltage, the Electromagnetic Compatibility and the Machinery Directives). In such cases, those directives still need to be complied with, which might lead to additional requirements related to placing on the market of components and their putting into service (e.g. the Machinery Directive).

Placing products on the market

This ETAG-Guideline is the basis to issue ETAs for Cold storage premises kits. As such, the ETA by itself is insufficient to place products on the market. In addition to the technical specification, attestation of conformity, resulting in an EC Declaration of conformity, is required before CE Marking is possible.

Cold storage premises kits consist of a large number of components. In most known cases, the "kit manufacturer" manufactures the most important components (e.g. wall, floor and roof panels), but he also buys a number of components from other manufacturers (suppliers), e.g. sealants and fixings. It is possible that the kit manufacturer does not manufacture any component and that he buys all components that enable him to assemble cold storage premises kits in accordance with his design requirements.

¹ In the absence of an existing harmonised technical specification and if manufacturers want to see separate components covered by a harmonised technical specification, enabling them to CE Mark these components, with the intention of (also) placing them on the market separately, manufacturers should apply for an ETA, which will initiate the process leading to such specifications.

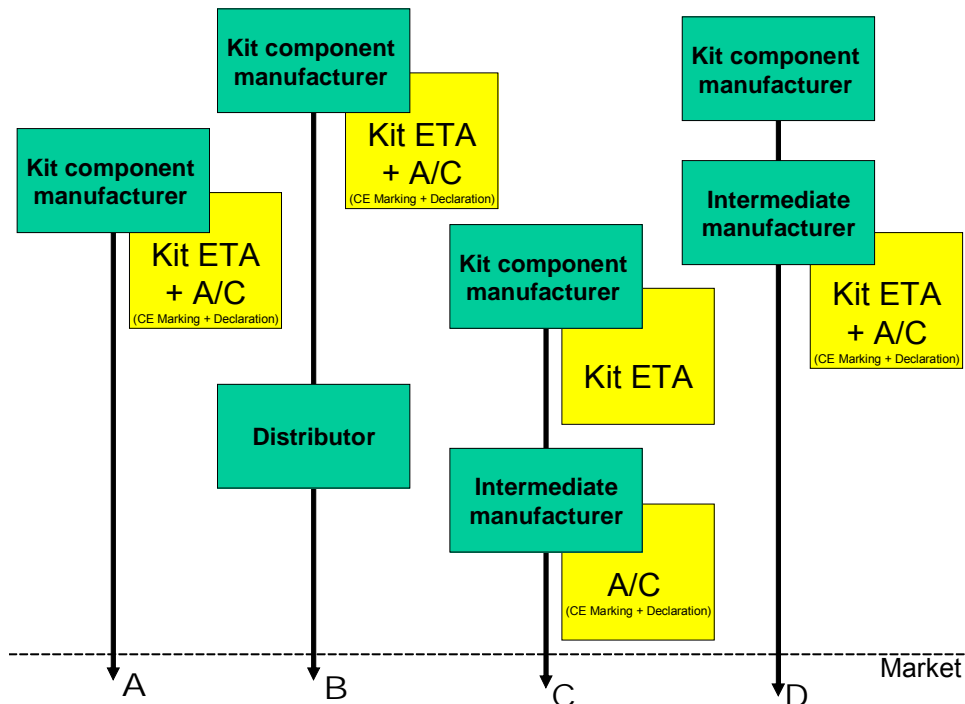

Figure 1: Known possibilities for placing cold storage premises kits on the market

Figure 1 presents a number of possibilities that exist for placing cold storage premises kits on the market:

- Case A is the "normal" case. The ETA-holder is also the party that also performs the attestation of conformity tasks and signs the EC Declaration of conformity. The kits go directly from the ETA-holder to the market.
- In Case B, the products are stored by a distributor who places the kits on the market. Because the latter does not modify (in any way) the kit, the kit manufacturer (ETA-holder) can also perform all A/C tasks. In this case, it is possible that the distributor benefits from a "duplicate" ETA and that the kits bear the distributor's name.
- Case C represents the possibility that the kit manufacturer has an ETA that covers a number of possible kits, where an intermediate manufacturer places on the market some or all of them. The choice of the components and therefore also the performance of the kit is determined by the intermediate manufacturer and he becomes responsible for signing the EC Declaration of conformity and CE Marking of the kit.
- Case D is the case where the kit manufacturer does not obtain his ETA and does not put the kit on the market. His responsibility is reduced to that of a supplier. The intermediate manufacturer obtains the ETA and also performs the attestation of conformity tasks.

In any case, there must be a technical and legal link between the manufacturer(-s) or supplier(-s) and the party signing the EC Declaration of conformity. In case of problems, market surveillance authorities will contact the party putting the CE Marking on the product (the party signing the declaration of conformity) and, where relevant, the legal and technical link will allow the authorities to also examine the A/C tasks performed by the manufacturer/supplier manufacturing the kit component.

Section One: INTRODUCTION

1. PRELIMINARIES

1.1 LEGAL BASIS

This ETA-Guideline has been established in compliance with the provisions of the Council Directive 89/106/EEC (Construction Products Directive) and has been established taking into account the following steps:

- | | |
|---|------------|
| - The final mandate issued by the EC | 2004-10-26 |
| - The final mandate issued by the EFTA | 2004-10-26 |
| - Adoption of the ETA-Guideline by the Executive Commission of EOTA | 2005-03-02 |
| - Opinion of the Standing Committee for Construction | 2005-03-02 |
| - Endorsement by the EC | 2005-11-16 |

This document is published by the Member States in the official language or languages according to Art. 11.3 of the Construction Products Directive.

No existing ETA-Guideline is superseded.

1.2 STATUS OF ETA-GUIDELINES

(a) **An ETA is one of two types of technical specifications** in the sense of the EC Construction Products Directive (89/106/EEC). This means that Member States shall presume that the approved products are fit for their intended use, i.e. they enable works in which they are employed to satisfy the Essential Requirements during an economically reasonable working life, provided that:

- the works are properly designed and built
- the conformity of the products with the ETA has been properly attested.

(b) This ETA-Guideline is a basis for ETA's, i.e. a basis for technical assessment of the fitness for use of a cold storage building envelope and building kit for an intended use. An ETA-Guideline is not in itself a technical specification in the sense of the Construction Products Directive.

This ETA-Guideline expresses the common understanding of the approval bodies, acting together within EOTA, as to the provisions of the EC Construction Products Directive 89/106 and of the Interpretative Documents in relation to the products and uses concerned, and is written within the framework of a mandate given by the Commission and the EFTA secretariat, after consulting the EC-Standing Committee for Construction.

(c) When accepted by the European Commission after consultation with the Standing Committee for Construction, this **ETA-Guideline is binding** for the issuing of ETA's for the kits for the defined intended uses

The application and satisfaction of the provisions of an ETA-Guideline (examinations, tests and evaluation methods) leads to an ETA and a presumption of fitness of a cold storage building envelope or building kit for the defined use only through an evaluation and approval process and decision, followed by the corresponding attestation of conformity. This distinguishes an ETA-Guideline from a harmonised European standard

that is the direct basis for attestation of conformity.

Where appropriate, cold storage building envelope or building kits, which are outside of the precise scope of this ETA-Guideline, may be considered through the approval procedure without guidelines according to art. 9.2 of the Construction Products Directive.

The requirements in this ETA-Guideline are set out in terms of objectives and of relevant actions to be taken into account. It specifies values and characteristics, the conformity with which gives the presumption that the requirements set out are satisfied, wherever the state of the art permits and after having been confirmed as appropriate for the particular product by the ETA.

2. SCOPE

2.1 SCOPE

This guideline covers those industrially prepared kits, marketed as a building or a building envelope, that are made of pre-designed and prefabricated components intended for production in series. The kits are assembled according to pre-designed technical solutions for joints and construction details.

The technical equipment (e.g. cooling systems) is excluded².

The ETA-Guideline also includes three-dimensional prefabricated cold storage building units transportable to site in flat-pack or three-dimensional format. These units may form a building individually or in conjunction (horizontally and/or vertically) with other units and rapidly provide a weatherproof envelope, possibly subject to final weathering, jointing between units, connection to services and any foundation connections (see §2.3.5.3).

The enclosure of the building is made out of sandwich panels with external and/or internal faces made of various materials and a homogeneous thermally insulating core, which consists of stone or glass wool, expanded or extruded polystyrene, polyurethane, polyisocyanurate, cellular glass or modified phenolic foam.

In the framework of this ETA-Guideline, thermally insulating products are considered to be products with a declared thermal conductivity lower than 0,06 W/(m.K) at 10 °C.

Cold storage building kits contain at least the load bearing structure and wall and roof panels or wall panels and a roof (not made out of panels), with ceiling panels. Cold storage building envelope kits contain at least wall and roof panels or wall panels and a roof (not made out of panels), with ceiling panels. Floor panels and/or finishes may be included. When the roof is not made out of (cold storage) panels, it is not necessarily part of the kit, but the ETA-applicant will need to specify (at least) the minimum requirements that it should meet (generic specification).

The structural components of a building kit may be manufactured as members, structural frames or as completely prefabricated building elements.

Although the sandwich panels used as a component of the kit shall be prefabricated, on site cutting of panels is permissible, if appropriate measures are taken (see §2.3.5.2).

The design of the kit has to provide solutions and components for cold storage buildings (wall, floor and ceiling panels, doors and gates, windows, sealants, building hardware, gaskets, supporting and fixing systems and ancillary components), taking into account performance classifications under the Essential Requirements and Interpretative Documents.

These buildings are designed for specific internal climates expressed by temperature intervals (e.g. +5/+0 °C; +5/-5°C; -5/-30 °C), which will be specified by the ETA-applicant, and declared in the ETA.

Although cold storage building and building envelope kits, intended to be used for other temperature ranges are not necessarily excluded from the scope, this ETA-Guideline covers cold storage buildings intended to store products at temperatures below +15 °C and above -40 °C.

This ETA-Guideline covers assessment necessary to show compliance with the EC Foodstuff Directive (93/43/EEC), the EC Food contact material Directives (the framework directive 89/109/EEC and the specific directives referred to) and related national legislation.

The ETA-Guideline “Cold storage premises kits” is divided into 2 parts. Both parts deal

² Automated doors, gates, etc. as a component of the kit are covered.

with specific aspects relating to a different intended use:

- Part 1: Cold storage room kits
- Part 2: Cold storage building and building envelope kits

Notes:

- This ETA-Guideline covers kits, which the manufacturer puts onto the market as such and for which he assumes responsibility, ensuring that the assembled kit is fit for its intended use if constructed in accordance with the manufacturer's specifications. Manufacturers who put onto the market one or more components separately, without assuming responsibility that the separate components can be assembled into a fit for use cold storage building or building envelope, are not covered by this ETA-Guideline (e.g. manufacturers putting onto the market only double metal faced insulating sandwich panels have to conform to prEN 14509 only).
- In most known cases, the wall and ceiling sandwich panels consist of two metal faces, usually consisting of galvanised or zinc/aluminium coated steel sheet, stainless steel sheet, aluminium sheet or glass fibre reinforced polyester. Floor panels (if any) often have other finishing layers, such as wood-based panels, with or without resilient floor coverings, smooth or embossed metal sheet, glass fibre reinforced polyester, etc.
- The term "envelope", in the framework of this ETA-Guideline, is used for the part of the building which provides a weatherproof membrane. The envelope is not a structural part of the building.
- This ETA-Guideline can only be used to issue ETAs for cold storage building envelope or building kits, not for separate components. Separate components can however obtain CE Marking on the basis of the ETA for the kit, if the components are put onto the market to extend or repair existing cold storage building envelopes or buildings (see §...).
- Some, or even all components may be manufactured in other factories, than that of the ETA-applicant, who assumes responsibility for putting the fit for use kit onto the market.
- When reference is being made to PUR in this ETA-Guideline, this term also includes PIR.

2.2 USE CATEGORIES, PRODUCT FAMILIES, KITS AND SYSTEMS

2.2.1 General

The cold storage building envelope and building kits are usually intended to be used in flower, chemical or food industry (dairy, meat, bakery, ...) and alike.

Synonyms for installed "cold storage building envelope and building kits" include prefabricated warehouses.

2.2.2 Robustness and rigidity

In the framework of this ETA-Guideline, several aspects of performance are assessed, from which an overall assessment of the robustness of the assembled system can be drawn.

The categories given in the tables beneath correspond to various degrees of exposure in use.

2.2.2.1 Impact resistance

Table 2.1: Definition of use categories – Dynamic loads for wall panels

Use category	Description
-	No Performance Determined
WI	Cold storage building envelopes and buildings accessible primarily to those with high incentive to exercise care. Small risk of accidents occurring and of misuse.
WII	Cold storage building envelopes and buildings accessible primarily to those with some incentive to exercise care. Some risk of accidents occurring and of misuse.
WIII	Cold storage building envelopes and buildings readily accessible to public and others with little incentive to exercise care. Risk of accidents occurring and of misuse.
WIV	Cold storage building envelopes and buildings as in WII and WIII, in case of failure risk includes the fall to a floor at a lower level, i.e. where the cold storage building envelope or building wall has the function of a barrier.
WV _E	Cold storage building envelopes and buildings as in WII and WIII, in case of high "safety in use" impact resistance. Subscript "E" gives the impact energy resisted.
This use category is related to the assessment foreseen in §6.1.4.1	

Table 2.2: Definition of use categories – Dynamic loads for roof panels

Use category ³	Description
-	No Performance Determined
CI	Cold storage building envelopes and buildings, where the roof is accessible for maintenance only. Small risk of accidents occurring and of misuse.
CII	Cold storage building envelopes and buildings, where the roof is accessible for maintenance. Some risk of accidents occurring and of misuse.
This use category is related to the assessment foreseen in §6.1.4.1	

2.2.2.2 Eccentric loading

Table 2.3: Definition of loading use categories – Eccentric vertical loads

Loading use category	Description
-	No Performance Determined
a	Heavy objects such as small shelves.
b	Very heavy objects such as refrigeration units, large shelves.
c	Roof panels, supported by profiles, which are eccentrically attached to wall panels.
d	Minimum requirement for France
This use category is related to the assessment foreseen in §6.1.4.3	

³ The use categories CI and CII can only be awarded if

- the requirement "Walkability" (§5.2.4.2.2.4) leads to a favourable assessment; and
- for roof panels which are supported by profiles, eccentrically attached to wall panels, if use category c (in table 2.3) has been awarded.

2.2.3 Walkability

Table 2.4: Definition of walkability categories

Use categories	Level of walkability	Explanation
A1	Not accessible roofs/ceilings (not even for installation)	These panels are considered not accessible. ⁴
A2	Roofs/ceilings, accessible for installation and maintenance only (always with protective measures)	The walkability of roof/ceilings panels depends both on the impact resistance of the panel assembly and on the walkability characteristics of the roof/ceilings panels. However, access should always be limited to a single person, taking due care. The frequency should be limited to approximately once a month.
A3	Roofs/ceilings, accessible with protective measures	The walkability of roof panels depends both on the impact resistance of the panel assembly and on the walkability characteristics of the roof/ceilings panels. The access on roof/ceilings panels with protective measures however should always be limited to a single person, taking due care.
A4	Roofs/ceilings, accessible without protective measures	The walkability of roof/ceilings panels depends both on the impact resistance of the panel assembly and on the walkability characteristics of the roof/ceilings panels. If no protective measures are foreseen, the roof/ceilings panels should be favourably assessed with reference to walkability. However, access on roof/ceilings panels should always be limited to a single person, taking due care.
This use category is related to the assessment foreseen in §6.2.1.2.2.2		

2.2.4 Food Safety compliance

In the framework of this ETA-Guideline, several aspects of performance are assessed, from which an overall assessment of the fitness to store food or feed can be derived. Distinction is being made into the following cold storage building envelope and building kits:

Table 2.5: Definition of use categories

Use Category	Description
F	Cold storage building envelope and building kits intended to be used to store (packaged and unpackaged) food or feed and for non-food and non-feed uses
PF	Cold storage building envelope and building kits intended to be used to store packaged food or feed and for non-food and non-feed uses
NF	Cold storage building envelope and building kits intended for non-food and non-feed uses
This use category is related to the assessment foreseen in §6.1.3.4, §6.2.3.4, §6.2.7.2.2, §6.3.3.4 and §6.4.3.4.	

In this ETA-Guideline, requirements, verification methods and criteria, especially related to Cold storage building envelopes and buildings kits intended to be used to store packaged and/or unpackaged food or feed are indicated as such. All other paragraphs apply to all Cold storage building envelope and building kits.

Note: Even though construction products are not designated with the "F"- or "PF"-symbol, this does not mean that those products are not suitable for use in food businesses, as the Directive 93/43/EEC foresees that food business operators have the possibility to satisfy the competent authority that materials used, although not in accordance with the requirements of the directive, are appropriate for the intended use.

⁴ This use category shall be used, both for ceiling panels which were not assessed (NPD) and those that do not meet the criteria for accessible roofs.

2.3 ASSUMPTIONS

2.3.1 General

The state of the art does not enable the development, within a reasonable time, of full and detailed verification methods and corresponding technical criteria/guidance for acceptance for some particular aspects or products. This ETA-Guideline contains assumptions taking account of the state of the art and makes provisions for appropriate, additional **case-by-case approaches** when examining ETA-applications, within the general framework of the ETA-Guideline and under the Construction Products Directive consensus procedure between EOTA members.

The guidance remains valid for other cases that do not deviate significantly. The general approach of the ETA-Guideline remains valid but the provisions then need to be used case-by-case in an appropriate way. This use of the ETA-Guideline is the responsibility of the ETA-body, which receives the special application, and subject to consensus within EOTA. Experience in this respect is collected after endorsement in EOTA TB, in the ETA-Format-Comprehension document.

2.3.2 Kit components and ancillary components

In the framework of this ETA-Guideline, distinction is being made between kit components and (construction) products that are not covered by the ETA, the latter will be referred to as Ancillary components:

- Components (1) where the cold storage intended use introduces the need to assess over and above product specifications that envisage "normal" intended uses
- Components (2) where the products do not require the need to assess over and above product specifications that envisage "normal" intended uses and where conformity with those specifications is sufficient for their use as a kit component.
- Products (Ancillary components) that are specified in the kit ETA, but not assessed as kit components. Only their possible influence on the essential requirements and fitness for use of the kit will be assessed.

2.3.2.1 Kit components

Some components (1) are products where the cold storage intended use introduces the need to assess over and above product specifications that envisage "normal" intended uses. These components are (exhaustive list):

- composite panels and their coatings and finishes
- structural components (building kits only)
- doors, gates and windows, roof windows and rooflights
- fixing systems
- building hardware
- gaskets
- sealants
- supporting profiles

Other components (2) are products where this ETA-Guideline does not require the need to assess over and above product specifications that envisage "normal" intended uses and where conformity with those specifications⁵ is sufficient for their use as a kit component.

⁵ The whole product standard is intended, as far as relevant for the intended use as a kit component. Compliance with CPD requirements is usually insufficient.

Examples are (not exhaustive list):

- provisions preventing falling due to changes in level or drops, e.g. stairs, guard rails, balustrades, barriers (e.g. ETAG 008, ISO/DIS 12055)
- rainwater disposal products (e.g. EN 607, EN 612, EN 1462)
- roof access products (e.g. EN 516, EN 517, EN 12951)
- roof covering products (e.g. EN 490, EN 492, EN 494, EN 501, EN 502, EN 504, EN 505, EN 506, EN 507, EN 508-1, -2 and -3, EN 534, EN 544, EN 1304, EN 12467, EN 12326-1)
- roof waterproofing products (e.g. EN 13707, EN 13956)
- rigid or flexible wall or roof underlays (e.g. EN 13859-1 and -2, prEN 14964)
- damp proofing membranes and water vapour control layers (e.g. EN 13967, EN 13969, EN 13970, EN 13984, prEN 14967, prEN 14909)

Note: In most cases, cold storage building and/or building envelope kit ETA-applicants will not manufacture such components (2) themselves and therefore, in most cases, suppliers should provide the relevant evidence related to product conformity with the above mentioned product specifications, but also related to fitness for use in this specific intended use (cold storage building or building envelope kit), as far as considered relevant by the approval body (e.g. wind uplift resistance of mechanically fastened waterproofing membranes on cold storage sandwich roof panels).

2.3.2.2 Ancillary components

Ancillary components are (construction) products, which are delivered with the kit and added on purchaser's request. The assessment of the ancillary product is generally not required to assess compliance of the kit with the relevant Essential Requirements, unless the incorporation of the ancillary component might decrease the kit's performances. Therefore, in most cases, if it is necessary, assessment shall be done on a case-by-case basis. The ancillary components are not covered by the ETA and this shall be clearly specified as such. Examples of ancillaries are (not exhaustive list):

- door kick plates
- hanging rails
- pressure relief provisions
- profiles (not supporting)
- ramp
- shelving (or racking)
- strip curtains
- wall protection provisions

2.3.3 Content of an ETA

This paragraph is intended to give guidance to Approval Bodies, when deciding whether an ETA-applicant is required to apply for more than one ETA.

A cold storage building envelope and building kit is to be covered by one ETA, as far as the composite panel composition (core and face material families⁶) remains the same, with the exception of the floor composite panels, where different faces and finishes are acceptable within one ETA to allow for various intended uses.

The composite panel finishes of wall and ceiling panels are allowed to vary within one ETA. The other components (doors, gates, windows, hardware, etc) and ancillary components of the kit (doors, gates, windows, hardware, etc) are also allowed to vary, both in nature, type and in number, as long as all the possible components and ancillary components are fully described in the ETA.

More than one ETA is required, if the composite panel composition varies and/or if the

⁶ Core material families (8 families): Glass/Stone wool, PUR/PIR, EPS, XPS, modified PF and CG
Face material families (2 families): both metal faces and all other (including combinations with 1 metal face)

cold storage building envelope and building design system changes.

Note: Cold storage room kits and cold storage building or building envelope kits cannot be covered in one ETA, even if the product put on the market is identical

2.3.4 Interchanging of components and ancillary components

This paragraph is intended to give guidance to Approval Bodies and ETA-applicants, to indicate what happens when a component, an accessory or materials are being modified, during the lifetime of an ETA.

For products supplied as kits, the ETA-holder has the following options regarding the specification of components and these options will have been taken into account by the Approval Body issuing the ETA:

- The incorporation of **specific components**; that is, components from a particular supplier that have been accepted by the Approval Body on the basis of their performance in the application.
- The incorporation of **generic components**; that is, components that have been accepted by the Approval Body on the basis of conformity to a relevant standard that fully covers the product in the application.

A kit could include specific and/or generic types of specifications for components.

Furthermore, it is likely that during the lifetime of an ETA, the ETA-holder will wish to change the specifications and/or supplier of some components.

It is the ETA-holder's responsibility to ensure that any product he puts on the market remains in conformity with the ETA. If the ETA-holder considers that any change to the product and/or production, e.g. interchanging of a component and/or supplier, would lead to the kit no longer complying with the ETA, he has the responsibility of informing the Approval body and the Approved certification body.

When informed by the ETA-holder, it is the responsibility of the approval body to assess the continuing conformity of the changed kit with the ETA and, where necessary, amend the ETA.

During its surveillance visits, the approved body verifies conformity of the produced kit with the ETA, taking into account documented evidence of assessment performed or being performed by the approval body due to reported changes. An approved certification body cannot assess whether product or production changes allow continuing fitness for use.

Where a component has been defined in terms of a specific supplier's product or where the new component, intended to replace a generically specified component might not fully cover the fitness of a component for use in a cold storage building envelope or building kit, any change can only be approved by the approval body issuing the ETA, on completion of additional verification as is deemed necessary.

Generally, in such cases, issuing a modified ETA will be necessary, with the consequent amendment of the instructions to the approved body.

Where a component of a cold storage building envelope or building kit is specified generically, e.g. by reference to a product standard or an ETA, and the Approval Body has confirmed, in the ETA the full adequacy of that specification to prove the fitness for use of the component in the cold storage building envelope or building kit, then a change of supplier will be acceptable.

The approved body checks the documentation as deemed necessary by the approval body issuing the ETA. In case of doubt reference shall be made to the approval body.

With an interchange of a component of a cold storage building envelope or building kit, it shall be ensured that the new component does not have a negative influence on the performance level or the working life of that product.

Note: Where reference to "supplier" is being made in this clause, this could either refer to the ETA-holder or another manufacturer.

2.3.5 Use of this ETA-Guideline

2.3.5.1 General

Depending on the product under assessment, and in accordance with the ETA-Guideline scope (see §2.1), the ETA-Guideline needs to be taken into account completely or only in part (see also the introductory notes of Section 2).

The kit assessment is based on the assessment of kit related verifications and criteria (respectively §5.1 and §6.1) and the component related verifications as specified in §5.2, §5.3 and §5.4 and criteria in §6.2, §6.3 and §6.4, if and where relevant for the kit under consideration and taking into account its intended use.

2.3.5.2 On-site cutting of panels

If the ETA-applicant's specifications allow on-site cutting of panels (e.g. to arrive at specific, not modular, dimensions, or to introduce windows, **roof windows and rooflights** or hatches), the influences on the kit's performance as far as the essential requirements is concerned, should be thoroughly checked.

On-site cutting might have important detrimental effects on a large number of performance characteristics, but especially water vapour and air tightness and on the durability of the panels.

2.3.5.3 Prefabricated cold storage units

Prefabricated cold storage units should be assessed on the basis of this ETA-Guideline, and in addition on the basis of the ETAG xx2 "Prefabricated building units", as far as the specific performances of the kit as a unit are concerned.

3. TERMINOLOGY

3.1 COMMON TERMINOLOGY AND ABBREVIATIONS

See Annex A.

3.2 SPECIFIC TERMINOLOGY AND ABBREVIATIONS RELATED TO THE PRODUCTS AND THEIR INTENDED USE COVERED BY THIS GUIDELINE

See Annex B.

Section Two: GUIDANCE FOR THE ASSESSMENT OF THE FITNESS FOR USE

Introductory Notes

(a) Applicability of the ETA-Guideline

This ETA-Guideline provides guidance on the assessment of a family of cold storage building envelope or building kits and their intended uses. It is the ETA-applicant who defines the kit for which he is seeking ETA and how it is to be used in the works, and consequently the scale of the assessment.

It is therefore possible that for some kits, which are fairly conventional, only some of the tests and corresponding criteria are sufficient to establish fitness for use. In other cases, e.g. special or innovative kits or materials, or where there is a range of uses, the whole package of tests and assessment may be applicable.

(b) General lay out of Section Two

The assessment of the fitness of products with regard to their fitness for intended use in construction works is a process with three main steps:

- Chapter 4 clarifies **the specific requirements for the works** relevant to the products and uses concerned, beginning with the Essential Requirements for works (CPD, Art. 11.2) and then listing the corresponding relevant characteristics or products.
- Chapter 5 extends the list in Chapter 4 into more precise definitions and the **methods available to verify** product characteristics and indicates how the requirements and the relevant product characteristics are described. This is done by test procedures, methods of calculation and of proof, etc.
- Chapter 6 provides guidance on **the assessing and judging methods to confirm fitness for the intended use** of the cold storage building envelope or building kits.
- Chapter 7 **assumptions and recommendations** are only relevant in as far as they concern the basis upon which the assessment of the cold storage building envelope or building kits is made concerning their fitness for the intended use.

(c) Levels or classes or minimum requirements, related to the essential requirements and to the product performance (see ID Clause 1.2 and EC Guidance Paper E)

According to the Construction Products Directive “Classes” in this ETA-Guideline refer only to mandatory levels or classes laid down in the EC-mandate.

This ETA-Guideline indicates however the compulsory way of expressing relevant performance characteristics for the cold storage building envelope or building kit. If, for some uses at least one Member State has no regulations, an ETA-applicant always has the right to opt out of one or more of them, in which case the ETA will state “No Performance Determined” (NPD) against that aspect, except for those properties for which, when no determination has been made, the cold storage building envelope and building kit no longer falls under the scope of the ETA-Guideline; such cases shall be indicated in the ETA-Guideline.

(d) Working life (durability) and serviceability

The provisions, test and assessment methods in this ETA-Guideline or referred to, have been written, based upon the assumed intended working life of the cold storage building envelope and building kit for the intended use of 10 years, except structural components, which have an intended working life of 25 years, provided that the assembled cold storage building envelope or building is subject to appropriate use and maintenance (in accordance with Chapter 7). These provisions are based upon the current state of art and the available knowledge and experience.

For non-structural components, the following conditions shall be met for permitting a working life of 25 years for non-structural components:

- The durability assessment foreseen in this ETA-Guideline shall be performed in any case;
- The ETA-applicant shall present documented evidence that identical products were being used 25 years ago (this may be done through "standard" fingerprinting techniques, e.g. gaschromatography, IR spectrography);
- The ETA-applicant shall present an overview of at least 10 works, where the kit components (especially the composite panels) have been used for similar or preferable the same uses as foreseen in this ETA-Guideline, for every year over the past 25 years, i.e. a total of 250 references; the approval body shall inspect a selection of those works to base its findings upon; these findings shall be reported in the evaluation report.

An "assumed intended working life" means that it is expected that, when an assessment following the ETA-Guideline-provisions is made, and when this working life has elapsed, the real working life may be, in normal use conditions, considerably longer without major degradation affecting the Essential Requirements.

The indications given as to the working life of a cold storage building envelope or building kit cannot be interpreted as a guarantee given by the ETA-holder or the approval body. They should only be regarded as a means for the specifiers to choose the appropriate criteria for cold storage building envelope or building kits in relation to the expected, economically reasonable working life of the works (based upon ID. Par. 5.2.2).

(e) Fitness for the intended use

According to the Construction Products Directive it has to be understood that within the terms of this ETA-Guideline, products shall "have such characteristics that the works in which they are to be incorporated, assembled, applied or installed, can, if properly designed and built, satisfy the Essential Requirements" (CPD, Art 2.1).

Hence, the cold storage building envelope or building kits must be suitable for use in construction works which (as a whole and in their separate parts) are fit for their intended use, account being taken of economy, and in order to satisfy the Essential Requirements. Such requirements must, subject to normal maintenance, be satisfied for an economically reasonable working life. The requirements generally concern actions that are foreseeable (CPD, Annex I, preamble).

4. REQUIREMENTS FOR WORKS AND THEIR RELATIONSHIP TO THE PRODUCT CHARACTERISTICS

This chapter sets out the aspects of performance to be examined in order to satisfy the relevant Essential Requirements, by:

- expressing in more detail, within the scope of the ETA-Guideline, the relevant Essential Requirements (ER's) of the Construction Products Directive in the Interpretative Documents (IDs) and in the mandate, for works or parts of the works, taking into account the actions to be considered, as well as the expected durability and serviceability of the works.
- applying them to the scope of the ETA-Guideline (cold storage building envelope and building kit and where appropriate its constituents, components and intended uses), and providing a list of relevant product characteristics and other applicable properties.

When a product characteristic or other applicable property is specific to one of the Essential Requirements, it is dealt with in the appropriate place. If, however, the characteristic or property is relevant to more than one Essential Requirement, it is addressed under the most important one with cross-reference to the other(s). This is especially important where an ETA-applicant claims "No Performance Determined" (NPD) for a characteristic or property under one Essential Requirement and it is critical for assessing and judging under another Essential Requirement. Similarly, characteristics or properties, which have a bearing on durability assessments, may be dealt with under ER1 to ER6, with reference under 4.7. Where there is a characteristic, which only relates to durability, this is dealt with in 4.7.

This chapter also takes into account further requirements, if any (e.g. resulting from other EC Directives) and identifies aspects of serviceability including specifying characteristics needed to identify the products (cf. ETA-format, par. II.2).

The relevant Essential Requirements, the relevant paragraphs of the corresponding Interpretative Documents and the related requirements to product performance are indicated in the following tables 4.1 and 4.2:

Table 4.1 Essential Requirements, the relevant paragraphs of the corresponding Interpretative Documents and the related requirements to product performance

ER	Corresponding ID Paragraph for works	Corresponding ID paragraph for product performance	Product Characteristics from the Mandate	ETAG paragraph on product performance	Related aspects of durability, serviceability and identification
1	§2.1.3 Collapse §2.1.4 Inadmissible deformation §2.1.5 Damage by an event, disproportionate to the original cause	3.2 (2) Permanent actions Variable actions Accidental actions	Mechanical resistance and stability**	§4.1**	As relevant for the cold storage building envelope kits, building kits and/or its components.

	Corresponding ID Paragraph for works	Corresponding ID paragraph for product performance	Product Characteristics from the Mandate	ETAG paragraph on product performance	
2	§4.2.3.3.1 Limitation of the generation of fire and smoke within the room of origin §4.2.3.4.2 b Limitation of spread of fire and smoke beyond the room of origin §4.2.4 Limitation of spread of fire for neighbouring construction works	§4.3.1.1 Products subject to reaction to fire requirements – walls §4.3.1.3.5.1 Products subject to resistance to fire requirements – partitions §4.3.1.2 Products for roofs subject to fire requirements	Reaction to fire Fire resistance External fire performance (of the roof covering)	§4.2.1 §4.2.2 §4.2.3	As relevant for the cold storage building envelope kits, building kits and/or its components.
3	§3.3.1.1 Air quality §3.3.1.2 Dampness Council directive 93/43/EEC and framework directive 89/109/EEC (and the specific directives referred to) §3.3.1.2 Dampness	§3.3.1.1.3.2 a Emission and release of pollutants §3.3.1.2.3.2.e Building products §3.3.1.2.3.2.e Building products	Release of dangerous substances Vapour permeability Moisture resistance Fitness for contact with food and feedstuffs Air tightness Water tightness	§4.3.1 §4.3.2 §4.3.3 §4.3.4 §4.3.5* §4.3.6	
4	§3.3.2.2 Behaviour on impact §3.3.1.2 Falling after slipping §3.3.6.2 Restricting the slipperiness of driving surfaces §3.3.2.2 Geometry (e.g. headroom) Presence of sharp or cutting edges Nature of surfaces (e.g. hardness, roughness) §3.3.2.2 Forces applied to a body	§3.3.2.3 mechanical resistance and stability §3.3.1.3 Falling after slipping §3.3.6.3 Slipperiness of driving surfaces §3.3.2.3 Definition of geometry §3.3.2.3 Safety devices characteristics	Impact resistance Mechanical resistance Resistance to eccentric loads Slipperiness (floors) Safety against personal injury Safety against entrapment Safety against collapse (due to air pressure differences)	§4.4.1 §4.4.2 §4.4.3 §4.4.4 §4.4.5 §4.4.6 §4.4.7	

			Product Characteristics from the Mandate	ETAG paragraph on product performance	
4 (cont.)	§3.3.1.2 Falling due to changes in level or sudden drops	§3.3.2.3 mechanical resistance and stability	Resistance to horizontal and eccentric loads Provisions preventing falling due to changes in level or sudden drops	§4.4.8	As relevant for the cold storage building envelope kits, building kits and/or its components.
5	2.3.1, 2.3.2, 2.3.2 Protection against air-borne and impact noise between enclosed spaces and from outside of works	4.3.2 Acoustic properties (according to 4.3.3)	Airborne sound insulation Impact sound insulation Sound absorption	§4.5.1 §4.5.2 §4.5.3	
6	§4.2 Energy consumption limitation	Table 4.2 Component characteristics	Thermal resistance Air permeability Water vapour permeability Thermal inertia	§4.6.1 §4.6.2 §4.6.3* §4.6.4	
<p>* Characteristics added for completeness. Cross references have been made between ER3 and ER6</p> <p>** ER1, Mechanical resistance and stability is only relevant for cold storage building kits, not for cold storage building envelope kits.</p>					

4.1 MECHANICAL RESISTANCE AND STABILITY

The Essential Requirement laid down in the Council Directive 89/106/EEC is as follows:
The Construction Works must be designed and built in such a way that the loadings that are liable to act on it during its construction and use will not lead to any of the following:

- *collapse of the whole or part of the works*
- *major deformations to an inadmissible degree*
- *damage to other parts of the works or to fittings or installed equipment as a result of major deformation of the load bearing construction*
- *damage by an event to an extent disproportionate to the original cause*

This essential requirement is not relevant for cold storage building envelope kits, but it is relevant for cold storage building kits.

Some aspects of mechanical resistance and stability are being considered either as part of "Safety in use" or as part of "Serviceability".

4.2 SAFETY IN CASE OF FIRE

The Essential Requirement laid down in the Council Directive 89/106/EEC is as follows:

The construction works must be designed and built in such a way that in the event of an outbreak of fire:

- *the load bearing capacity of the construction can be assumed for a specific period of time*
- *the generation and spread of fire and smoke within the works are limited*
- *the spread of fire to neighbouring construction works is limited*
- *occupants can leave the works or be rescued by other means*
- *the safety of rescue teams is taken into consideration*

The following aspects of performance are relevant to this Essential Requirement for cold storage building envelope and building kits:

4.2.1 Reaction to Fire

The reaction to fire performance of cold storage building envelope and building kits and its components shall be in accordance with laws, regulations and administrative provisions applicable to cold storage building envelope and building kits and its components in its intended end use application. This performance shall be expressed in the form of a classification specified in accordance with the relevant EC decision and the appropriate CEN classification standards.

4.2.2 Resistance to Fire

The resistance to fire performance of cold storage building envelope and building kits shall be in accordance with laws, regulations and administrative provisions applicable to cold storage building envelope and building kits in its intended end use application. This performance shall be expressed in the form of a classification specified in accordance with the relevant EC decision and the appropriate CEN classification standards.

4.2.3 External fire performance (of the roof covering)

The external fire performance of the cold storage building envelope or building roof covering shall be in accordance with laws, regulations and administrative provisions applicable to the roof covering in its intended end use application. This performance shall be expressed in the form of a classification specified in accordance with the relevant EC

decision and the appropriate CEN classification standards.

4.3 HYGIENE, HEALTH AND THE ENVIRONMENT

The Essential Requirement laid down in the Council Directive 89/106/EEC is as follows: *The construction works must be designed and built in such a way that it will not be a threat to the hygiene or health of the occupants or neighbours, in particular as a result of any of the following:*

- *the giving-off of toxic gases*
- *the presence of dangerous particles or gases in the air*
- *the emission of dangerous radiation*
- *pollution or poisoning of the water or soil*
- *faulty elimination of waste water, smoke, solid or liquid wastes*
- *the presence of damp in parts of the works or on surfaces within the works.*

The following aspects of performance are relevant to this Essential Requirement for cold storage building envelope and building kits, in so far as "occupants" refers to users of the cold storage building envelopes and buildings and that requirements related to "neighbours" do not apply.

4.3.1 Release of dangerous substances

The cold storage building envelope and building kits, including all components and ancillary components shall be such that, when installed according to the appropriate provisions of the Member States, it allows for the satisfaction of the ER3 of the CPD as expressed by the national provisions of the Member States and in particular does not cause harmful emission of toxic gases, dangerous particles or radiation to the indoor environment nor contamination of the outdoor environment (air, soil or water).

4.3.2 (Water) vapour permeability

The design of the cold storage building envelope and building kits shall be such that when the product is in service there will be no threat to the health of the users as a result of presence of moisture condensation which could promote the growth of fungi or other micro organisms or flow or otherwise enter the building envelope or building (relevant also for consideration under ER6). This requirement is strongly related to the durability of the assembled kits.

4.3.3 Moisture resistance

The design of the cold storage building envelope and building kits and/or the composition of its components shall be such that when the product is in service there will be no threat to the health of the users as a result of presence of moisture condensation which could promote the growth of fungi or other micro organisms or flow or otherwise enter the building envelope or building, no loss of adhesion between core and faces of the composite panels, and no loss of thermal resistance. This requirement is strongly related to ER4, ER6 and the durability of the assembled kits.

4.3.4 Fitness for contact with food and feedstuffs

If the cold storage building envelope and building kits are intended to store foodstuffs (or feedstuffs), the design and/or the composition of its components shall be such that the assembled products meet the requirements of Council Directives 93/43/EEC and 89/109/EEC, and the related specific directives for food contact materials.

Requirements for kits as a whole

Cold storage building envelope and building kits intended for storage of food and/or feed shall be designed to permit adequate cleaning and/or disinfection. They shall be such as to protect against the accumulation of dirt, contact with toxic materials, the shedding of particles into food and the formation of condensation or undesirable mould on surfaces.

The assembled kits shall permit good food hygiene practices and provide, where necessary, suitable temperature conditions for the hygienic storage of products and shall have adequate natural and/or artificial lighting.

Requirements for kit components

In general, surfaces in contact with food or feed shall be easy to clean and, where necessary, disinfect. This shall require the use of smooth, washable and non-toxic materials.

Floor surfaces shall be easy to clean and, where necessary, disinfect. In general, this shall require the use of impervious, non-absorbent, washable and non-toxic materials.

Wall surfaces shall be easy to clean and, where necessary, disinfect. In general, this shall require the use of impervious, non-absorbent, washable and non-toxic materials and require a smooth surface up to a height appropriate for the operations.

Ceilings and overhead fixtures shall be designed and finished to prevent the accumulation of dirt and to reduce condensation, the growth of undesirable moulds and the shedding of particles.

Windows and other openings shall be designed to prevent the accumulation of dirt. Those which can be opened to the outside environment shall, where necessary, be fitted with insect-proof screens, which can be easily removed for cleaning.

Doors and gates shall be easy to clean and, where necessary, disinfect. This shall require the use of smooth and non-absorbent surfaces.

4.3.5 Air tightness

The design of the cold storage building envelope and building kits shall be such that when the product is in service, there shall be no threat to the health of the users of the stored products as a result of air infiltration (this aspect is being considered under ER6).

4.3.6 Water tightness

The design of the cold storage building envelope and building kits shall be such that when the product is in service, there shall be no threat to the health of the users as a result of water infiltration.

4.4 SAFETY IN USE

The Essential Requirement laid down in the Council Directive 89/106/EEC is as follows: *The construction works must be designed and built in such a way that it does not present unacceptable risks of accidents in service or in operation such as slipping, falling, collision, burns, electrocution, injury from explosion, etc.*

The following aspects of performance are relevant to this Essential Requirement for cold storage building envelope and building kits:

4.4.1 Impact resistance

The risk and effect of direct impact shall be considered in relation to accidental collisions of persons with parts of the cold storage building envelope and building, for example opening parts and/or the possibility of persons falling through brittle elements.

4.4.2 Mechanical resistance

The cold storage building envelope and building kits shall have sufficient mechanical resistance and stability under all loading conditions or combinations, foreseeable for the application, to ensure that the safety of the users is not endangered.

4.4.2.1 Fixing resistance

The risk and effect of components, elements or objects attached to components falling down due to insufficient fixing resistance of the fixing system, the panel lock system or insufficient strength of the area of the component where the fixing is applied shall be considered in relation to collisions from objects being suspended, or attached, with users of the cold storage building envelopes and buildings.

4.4.2.2 Mechanical resistance of wall, ceiling and floor panels

The risk and effect of parts of panels falling down due to insufficient mechanical resistance shall be considered in relation to loads likely to work on the panels or collisions from those parts with users of the cold storage building envelopes and buildings.

4.4.2.3 Mechanical resistance of the cold storage building envelopes

The risk and effect of parts of the cold storage building envelopes and buildings falling down due to insufficient mechanical resistance shall be considered in relation to loads likely to work on the building envelopes. For cold storage building kits this characteristic is covered under ER1.

4.4.3 Resistance to eccentric loads

The risk and effect of eccentric loads being applied to wall or ceiling elements shall be considered in relation to collisions from suspended or attached objects with users of the cold storage building envelopes and buildings.

This requirement is also relevant when the ceiling is being supported by a fixing system, fastened to wall panels.

4.4.4 Slipperiness (of floor surfaces)

The floor of the cold storage building envelope and building kits shall not be slippery, preventing users from slipping and/or falling, or vehicles from skidding, under all foreseeable conditions for the application, to ensure that the safety of the users is not endangered.

4.4.5 Safety against personal injuries by contact

The geometry of the assembled kit, the existence of sharp cutting edges and the nature of surfaces of the assembled kit shall not expose users to personal injury by contact.

This requirement is especially relevant in case the cold storage building envelope or building components are intended to support ceiling panels, technical equipment or shelving.

4.4.6 Safety against entrapment

The cold storage building envelope and building kit shall provide solutions preventing people from being trapped inside the assembled cold storage building envelope or building.

4.4.7 Safety against collapse (due to air pressure differences)

The cold storage building envelope and building kit shall provide solutions preventing collapse of components or of the whole assembled kit when in service, due to build-up of air pressure differences, between interior and exterior, occurring when the temperature inside the assembled cold storage building envelope and building changes quickly.

4.4.8 Resistance to horizontal and eccentric loads and provisions preventing falling due to changes in level or sudden drops

The cold storage building or building envelope kit shall have sufficient mechanical resistance and stability to ensure that the safety of the users is not endangered.

This means that it shall have sufficient mechanical resistance and stability to withstand accidentally large static or dynamic loads, from the action of persons or objects, without full or partial collapse causing dangerous (sharp or cutting) fragments, giving risk of falling through, particularly at a change of level, or endangering the safety of other people.

The loads may be in the form of:

- impacts resulting from a person falling against the building or building envelope
- differential air pressure
- impacts resulting from the movement of heavy non-deformable objects, such as equipment
- heavy objects, such as cooling equipment.

Cold storage building kits and buildings formed from the kits shall be so designed that the risk to occupants by falling due to changes in level or sudden drops is minimised. This can be achieved by minimising the hazard itself or ensuring that protective measures are used.

To protect persons against falling appropriate guardrails, balustrades or barriers can protect accessible openings. Appropriate stairways can be used at changes in levels. Such measures shall meet with regulatory requirements where the building is erected.

4.5 PROTECTION AGAINST NOISE

The Essential Requirement laid down in the Council Directive 89/106/EEC is as follows: *The construction works must be designed and built in such a way that noise perceived by the occupants or people nearby is kept down to a level that will not threaten their health and will allow them to sleep, rest and work in satisfactory conditions.*

4.5.1 Airborne sound insulation

Walls and floors shall provide the necessary airborne sound insulation applicable to the intended use of the building.

The external envelope shall provide the necessary sound insulation applicable to the intended use of the building concerning airborne noise from the outside (i.e. noise from industry, road and air traffic etc.).

4.5.2 Impact sound insulation

Floors shall provide the necessary impact sound insulation applicable to the intended use of the building.

4.5.3 Sound absorption

The internal surfaces which are part of the kit shall provide the necessary sound absorption applicable to the intended use of the building.

4.6 ENERGY ECONOMY AND HEAT RETENTION

The Essential Requirement laid down in the Council Directive 89/106/EEC is as follows: *The construction works and its heating and ventilation installations must be designed and built in such a way that the amount of energy required in use shall be low, having regard to the climatic conditions of the location and the requirements of the occupants.*

The following aspects of performance are relevant to this Essential Requirement for cold storage building envelope and building kits, as far as "occupants" refers to products being stored in the cold storage building envelopes and buildings.

- *limit energy consumption caused by radiation, convection or draught*
- *limit water vapour condensation within the cold storage building envelope and building or onto any of its surfaces.*

4.6.1 Thermal resistance

The thermal transmittance / resistance of the cold storage building envelope and building kit shall be used to establish that it is in accordance with laws, regulations and administrative provisions, applicable for the location where the product is incorporated in the works.

If there is any discontinuity in the assembled system, such as the system frame or the fixing system, then the effect of thermal bridging shall be considered.

4.6.2 Air permeability

The rate of air infiltration through the cold storage building envelope and building enclosure shall be considered with particular reference to junctions, penetrations and doors, gates and glazing (relevant also for consideration under ER3)

4.6.3 Water vapour permeability

The cold storage building envelope and building kit shall be designed, constructed and installed in such a way that moisture transfer does not cause excessive water vapour condensation within the cold storage building envelope and building or on its internal surfaces (*this aspect is being considered under ER3*).

4.6.4 Thermal inertia

Thermal inertia of the main building parts shall be known where applicable in order to assess the effect on energy and heat retention.

4.7 ASPECTS OF DURABILITY, SERVICEABILITY AND IDENTIFICATION

4.7.1 Durability

The requirements considered in the following paragraphs are related to the Essential Requirements, but not to any one requirement in particular. As a consequence, failure to meet these requirements means that more than one of the Essential Requirements may no longer be met.

Cold storage building envelope and building assemblies and components and their possible finishes shall be protected against / resistant to deterioration caused by physical, chemical or biological agents in order to prevent reduction of mechanical or other properties:

Physical agents

- Variations in temperature/humidity
- Differential temperature and/or relative humidity
- Ageing effects, due to temperature cycling and thermal shock

Chemical agents

- Water, carbon dioxide, oxygen (possible corrosion) and other normal chemical hazards likely to come into contact, for example cleaning materials.
- Chemical substances being stored or deriving from products being stored

Biological agents

- Fungi, bacteria, algae and insects.
- The cold storage building envelope and building kit shall be designed and built in such a way that it does not encourage infestation by insects or vermin.

4.7.2 Serviceability

The requirements considered in the following paragraphs are not related to the Essential Requirements, but are necessary for the cold storage building envelope and building kit to be fit for its intended use.

Provisions related to the kit as a whole:

- Rigidity and robustness

Provisions related to the components of the kit:

- Panels:
 - Panel finishes, influences from products being stored
 - Behaviour between two different climates
 - General serviceability of composite panels
- Windows, **roof windows and rooflights** & doors and gates:
 - Behaviour between two different climates
 - Behaviour under repeated opening and closing
 - Behaviour under operating forces
 - Resistance to vertical load and static torsion
 - Defrost provisions for doors and gates
 - Light transmittance
- Fixing systems: compatibility with temperature range
- Sealants:
 - Tensile properties
 - Adhesion / cohesion properties at variable temperatures
- Gaskets: compatibility with temperature range
- Building hardware: compatibility with temperature range

4.7.3 Identification

The materials, products and components used in the cold storage building envelope and building kits shall be identifiable as regards properties which have an influence on the ability of the kit to fulfil the Essential Requirements as described above.

5. METHODS OF VERIFICATION

This Chapter refers to the verification methods used to determine the various aspects of performance of the products in relation to the requirements for the works (calculations, tests, engineering knowledge, site experience, etc.) as set out in chapter 4.

The possibility exists to use existing data in accordance with the EOTA Guidance Document No. 4 on "the provision of data for assessment leading to ETA".

Not all the Essential Requirements will be relevant to every kit. A 'No Performance Determined' (NPD) option is possible in some cases and it will be for the ETA-applicant to decide, taking account of his intended market, which options he wishes to have assessed.

When Eurocodes are quoted in this ETA-Guideline as the methods for the verification of certain product characteristics, their application in this ETA-Guideline, as well as in the subsequent ETAs, issued according to this ETA-Guideline, shall be in accordance with the principles laid down in the EC Guidance Paper L on the use of Eurocodes in harmonised European technical specifications.

The relevant Essential Requirements, the corresponding product characteristics to be assessed and the corresponding verification methods are indicated in the following table 5.1:

Table 5.1 Product characteristics and corresponding verification methods

ER	ETAG paragraph on product performance	ETAG paragraph on verification method of product characteristics	
		Kits	Components
1	§4.1 Mechanical resistance and stability	§5.1.1	§5.2.1, §5.2.1, §5.3.1, §5.4.1 and §5.5.1
2	§4.2.1 Reaction to fire	§5.1.2.1	§5.2.2.1, §5.3.2.1, §5.4.2.1 and §5.5.2.1
	§4.2.2 Fire resistance	§5.1.2.2	§5.2.2.2, §5.3.2.2 and §5.4.2.2
	§4.2.3 External fire performance	§5.1.2.3	§5.2.2.3, §5.3.2.3 and §5.4.2.3
3	§4.3.1 Release of dangerous substances	§5.1.3.1	§5.2.3.1, §5.3.3.1, §5.4.3.1 and §5.5.3.1
	§4.3.2 Vapour permeability	§5.1.3.2	§5.2.3.2, §5.3.3.2 and §5.4.3.2
	§4.3.3 Moisture resistance	§5.1.3.3	§5.2.3.3, §5.3.3.3 and §5.4.3.3
	§4.3.4 Fitness for contact with food and feedstuffs	§5.1.3.4	§5.2.3.4, §5.3.3.4 and §5.4.3.4
	§4.3.5 Air tightness	§5.1.3.5*	§5.2.3.5, §5.3.3.5 and §5.4.3.5*
	§4.3.6 Water tightness	§5.1.3.6	§5.2.3.6, §5.3.3.6 and §5.4.3.6

ER	ETAG paragraph on product performance	ETAG paragraph on verification method of product characteristics	
		Kits	Components
4	§4.4.1 Impact resistance	§5.1.4.1	§5.2.1.1, §5.3.4.1 and §5.4.4.1
	§4.4.2 Mechanical resistance	§5.1.4.2	§5.2.1.2, §5.3.4.2, §5.4.4.2 and §5.5.4
	§4.4.3 Resistance to eccentric loads	§5.1.4.3	§5.2.1.3, §5.3.4.3 and §5.4.4.3
	§4.4.4 Slipperiness (floors)	§5.1.4.4	§5.2.4.2, §5.3.4.4 and §5.4.4.4
	§4.4.5 Safety against personal injury	§5.1.4.5	§5.2.4.3, §5.3.4.5 and §5.4.4.5
	§4.4.6 Safety against entrapment	§5.1.4.6	§5.2.4.4, §5.3.4.6 and §5.4.4.6
	§4.4.7 Safety against collapse (due to air pressure differences)	§5.1.4.7	§5.2.4.5, §5.3.4.7 and §5.4.4.7
	§4.4.8 Resistance to horizontal and eccentric loads		
	- hard body impacts	§5.1.4.1	§5.2.1.1 and §5.3.4.1
	- soft body impacts		
- eccentric vertical loads	§5.1.4.3	§5.2.4.3, §5.3.4.3 and §5.4.4.3	
Provisions preventing falling due to changes in level or sudden drops	§5.1.4.8	-	
5	§4.5.1 Airborne sound insulation	§5.1.5.1	§5.2.5.1, §5.3.5.1 and §5.4.5.1
	§4.5.2 Impact sound insulation	§5.1.5.2	§5.2.5.2, §5.3.5.2 and §5.4.5.2
	§4.5.3 Sound absorption	§5.1.5.3	§5.2.5.3, §5.3.5.3 and §5.4.5.3
6	§4.6.1 Thermal resistance	§5.1.6.1	§5.2.6.1, §5.3.6.1, §5.4.6.1 and §5.5.6
	§4.6.2 Air permeability	§5.1.6.2	§5.2.6.2, §5.3.6.2 and §5.4.6.2
	§4.6.3 Water vapour permeability	§5.1.6.3*	§5.2.6.3, §5.3.6.3 and §5.4.6.3*
	§4.6.4 Thermal inertia	§5.1.6.4	§5.2.6.4, §5.3.6.4 and §5.4.6.4
	Durability	§5.1.7.1	§5.2.7.1, §5.3.7.1, §5.4.7.1 and §5.5.7.1
	Serviceability	§5.1.7.2	§5.2.7.2, §5.3.7.2 and §5.4.7.2
	Identification	§5.1.7.3	§5.2.7.3, §5.3.7.3, §5.4.7.3 and §5.5.7.2

* Characteristics added for completeness. Cross references have been made between ER3 and ER6

5.1 VERIFICATION METHODS RELEVANT FOR THE KIT / ASSEMBLED SYSTEM

5.1.1 Mechanical Resistance and Stability

5.1.1.1. Verification of structural capacities in general

The structural components and the structure shall be verified in conformity with the basis of structural design as given in EN 1990, i.e. in accordance with the limit state design method, and taking into account the actions on structures in accordance with EN 1991-1. The verification can normally be undertaken by structural calculations, supplemented if necessary by testing in special cases, and shall when relevant include resistance against disproportionate collapse.

Alternatively, indication of geometrical data of the kit components and of properties of the materials and constituent products used, can also be considered sufficient.

Combining the above mentioned assessment methods is also permitted.

Notes:

1. Although indication of geometrical data is acceptable (EC Guidance Paper L), it will necessitate structural calculations on a case-by-case basis, once the ETA has been delivered.
2. Design situations in EN 1991-1 also includes transient situation which refer to temporary conditions applicable to the structure, e.g. during execution or repair.
3. EN 1991-1 specifies the various actions that may apply:
 - EN 1991-1-1: Densities, self-weight, imposed loads for buildings;
 - EN 1991-1-2: Actions due to exposure to fire;
 - EN 1991-1-3: Snow loads;
 - EN 1991-1-4: Wind actions;
 - EN 1991-1-5: Thermal actions;
 - EN 1991-1-6: Actions during execution;
 - EN 1991-1-7: Accidental actions from impact and explosions)

5.1.1.2 Indication of geometrical data

The Approval body shall verify at least the following information:

- the geometrical data (dimensions and cross sections, including tolerances) of the structural kit components and of the assembled kit
- the properties of the materials and constituent products used that are needed to determine, according to the National Provisions, valid in the place of use, or possible use, load-bearing capacities and other properties, including aspects of durability and serviceability, of the assembled kit installed in the works, as far as possible.

Note: The possibility of providing geometrical data is especially relevant in those cases where Eurocodes are not available, e.g. due to:

- the nature of the structural components (e.g. composite panels)
- the constituent materials of structural components (e.g. plastic columns).

5.1.1.3. Verification by calculation

Calculations should be made according to relevant parts of the Eurocodes to verify that the structural components and the structure do not exceed the relevant ultimate state:

- EN 1992-1-1 and EN 1992-1-2 for concrete elements
- EN 1993-1-1 and EN 1993-1-2 for steel elements
- EN 1994-1-1 and EN 1994-1-2 for composite steel-concrete elements
- EN 1995-1-1 and EN 1995-1-2 for timber elements
- EN 1999-1-1 and EN 1999-1-2 for aluminium elements

Supplementary calculations which are relevant for the resistance against seismic actions

should be performed in accordance with the provisions of EN 1998-1, for various materials and elements. Other information on capacities against seismic actions based on Nationally Determined Parameters (NDP) or other national regulations may be undertaken as a basis for the specific structural design for each individual work.

Note: National annexes to the Eurocodes may provide supplementary information, alternative procedures, values and recommendations for classes. Each Eurocode indicates which clauses provide national choices.

5.1.1.4. Verification assisted by testing

Where calculations rules or material properties given in the referenced Eurocodes according to §5.1.1.3 of this part of the ETA-Guideline are not sufficient or where economy may result from tests on the products under consideration, part of the design procedure may be performed on the basis of tests. In general, this design assisted by testing shall be done according to Annex D of EN 1990.

Only test methods which are part of this ETA-Guideline (or Progress file), may be used, or, alternatively, those specified in European standards (CEN), International standards (ISO), EOTA Technical Reports, UEAtc Guidelines, Nordtest standards or RILEM test methods⁷. If such alternatives are being used, the ETA shall specify the method in sufficient detail (the specification's reference and edition, and, if relevant, any deviations made, compared with the specified method).

The following general principles shall be adopted for alternative tests:

- Choose the test configuration to create the appropriate mode of failure (e.g. bending)
- Avoid undue influence arising from the method of load application and member support.
- Make sure that the load transmission principles within the arrangement are determinable, e.g. by using additional load cells to determine the exact load transferred by the building unit or element; if relevant, the weight of the test equipment should be taken into account in the recorded data.
- Determine and record the relevant characteristics of the components tested and of the material used to manufacture the component, e.g. dimensions of components and coupon tests to establish actual tensile strength of material tested.
- A comprehensive record of load-deformation behaviour should be made for each variable of interest.
- Testing may be carried out using incremental or continuous loading.

5.1.1.4.1 Fixing resistance

5.1.1.4.1.1 General

For fixing resistance the verification methods depend on the way in which the composite panels are being mechanically fastened. It is possible that for one kit, more than one possibility arises (e.g. wall panels are connected by panel lock systems, while the ceiling panel is supported by a provision connected to the load-bearing structure of the surrounding building).

Finally, fixing resistance is also relevant as far as components or accessories are fixed to other cold storage building kit components.

5.1.1.4.1.2 Kits, where the composite panels are connected, without being mechanically fastened to a supporting system.

If the composite panels are not being mechanically fastened to a supporting system, the fixing resistance is relevant for the panel lock system, which is an integral part of the composite panels. The assessment shall be performed through an assembly test, as referred to in §5.1.1.4.1.3.2 of this part of the ETA-Guideline.

⁷ Preference shall be given to test methods from the organisation which is highest on the list.

5.1.1.4.1.3 Kits, where the composite panels are mechanically fastened to a supporting system

If the composite panels are being mechanically fastened to a supporting system, the fixing resistance is relevant for the composite panels and the fixing system only (See §5.2.4.2.1.2 and §5.4.4.2.1 of this part of the ETA-Guideline). The assessment of the supporting system is being treated in §5.1.1.4.1.3.1 of this part of the ETA-Guideline.

5.1.1.4.1.4 Kits, where fixing resistance is necessary to attach components or accessories to other cold storage building kit components

In the framework of this ETA-Guideline, this aspect is being treated as an aspect related to the fixing system (See §5.4.4.2.1 of this part of the ETA-Guideline).

5.1.1.4.2 Mechanical resistance of kit components

See §5.2.4.2.2, §5.3.4.2.2 and §5.4.4.2.2 of this part of the ETA-Guideline.

5.1.1.4.3 Mechanical resistance of the cold storage buildings

5.1.1.4.3.1 Mechanical resistance of the supporting system

In case the kit foresees an internal or external supporting system to support the ceiling panel and additional weight (e.g. technical equipment or internal hanging rails), then this supporting system shall be assessed in accordance with the relevant Eurocodes and the possible influences of these provisions on the ER2, ER3, ER4 and ER6 of the kit as a whole.

Given the number of possibilities, the assessment should be performed on a case-by-case basis and in line with provisions in the Eurocodes.

5.1.1.4.3.2 Racking resistance of the cold storage buildings

5.1.1.4.3.2.1 General

The racking resistance of wall panel assemblies shall be determined in accordance with this ETA-Guideline, Part 1, Annex D.

The test method in this ETA-Guideline, Part 1, Annex D, only provides information related to safety in use. Test results shall be accompanied by the following note: "These test results are related to safety in use requirements. Resistance to loads resulting in serviceability failure can be significantly lower."

For products covered by the Eurocodes, the following may be used in addition.

5.1.1.4.3.2.2 Racking tests on full size panels

The racking resistance of a full size panel may be tested directly using this test. In such cases the characteristic values for racking stiffness and racking strength shall be established in accordance with the statistical procedures given in EN 1990, clause 10. However, the data should be examined to ensure that obviously erroneous data does not unduly influence the statistical analysis.

The design racking resistance of the panel will then be the lesser of either:

- i) the characteristic stiffness determined racking load or
- ii) the characteristic racking strength divided by an appropriate factor γ_{rs} .

The factor shall be determined as follows:

For materials with partial factors defined in Eurocodes then

$$\gamma_{rs} = 1,6 \times \text{the material factor from the Eurocode}$$

In other cases and such as where racking performance relies adhesives, foams, or bond between composite products or several complimentary factors then

$$\gamma_{rs} = 1,5 \times 1,6 \times \gamma_m \text{ material factor} \times \gamma_{lt} \text{ long term factor}$$

where

γ_m = a material factor based on the most appropriate value from a Eurocode and

γ_{lt} = a factor to cover long term reduction in bond properties to be used if appropriate.

Note: In those cases where the Eurocodes do not provide the required γ_m , the value used in the ETA shall be specified.

5.1.1.4.3.2.13 Racking tests on other panels

The racking characteristics for the panel tested shall be analysed as above. The data generated can be converted to provide the specific values for the panels in the cold storage room kit as follows:

$$F_{kp} = K_b \times K_h \times F_{test,k}$$

Where:

F_{kp} is the design racking resistance of the panel

$F_{test,k}$ is the design racking resistance of the panel of the panel tested

K_b is the breadth coefficient and

$$K_b = b / b_{test}, \text{ if } b > b_{test} \text{ or}$$

$$K_b = (b / b_{test})^2, \text{ if } b > b_{test} / 2 \text{ or}$$

$$K_b = 0, \text{ if } b < b_{test} / 2$$

K_h is the height coefficient and

$$K_h = (h_{test} / h)^2, \text{ if } h \geq h_{test} \text{ or}$$

$$K_h = 1, \text{ if } h < h_{test}$$

b is the width of the cold storage room and b_{test} is the width of the panel tested

h is the height of the cold storage room and h_{test} is the height of the panel tested

The type and spacing of fixing at the lower and upper face of the panel and between the sheathing and the structural members must be identical in the panel under evaluation with the tested panel.

5.1.2 Safety in case of Fire

5.1.2.1 Reaction to fire

Determination of the reaction to fire of cold storage building and building envelope kits shall be undertaken by verification of the reaction to fire of its components (see §5.2.2.1, §5.3.2.1 and §5.4.2.1 of this part of the ETA-Guideline).

5.1.2.2 Fire resistance

See §5.1.2.2 of this ETA-Guideline, Part 1.

5.1.2.3 External fire performance (of the roof covering)

The external fire performance of cold storage building and building envelope kit components shall be verified using the appropriate method out of the following:

- The component, or the assembled system of which the component may form part of, shall be tested using the test method relevant for the corresponding external fire performance roof class, in order to be classified according to EN 13501-5
- The component, or the assembled system of which the component may form part of, is considered to satisfy all the provisions for external fire performance of all national regulations of the Member States without the need for testing on the basis that it is included within the definitions given in Commission Decision 2000/553/EC and provided that any national provisions on the design and execution of works are fulfilled. In this case, the Approval body shall verify product compliance with the definitions of the decision.

- The component, or the assembled system of which the component may form part of, is considered to satisfy the requirements for performance class of the characteristic external fire performance in accordance with an EC Decision published in the OJEC without the need for testing on the basis of its conformity with the specification of the product detailed in that EC Decision and its intended end use application being covered by that EC Decision. In this case, the Approval body shall verify product compliance with the definitions of the decision.

5.1.3 Hygiene, Health and the Environment

5.1.3.1 Release of dangerous substances

See §5.1.3.1 of this ETA-Guideline, Part 1.

5.1.3.2 Water vapour permeability

See §5.1.3.2 of this ETA-Guideline, Part 1.

5.1.3.3 Moisture resistance

See §5.1.3.3 of this ETA-Guideline, Part 1.

5.1.3.4 Fitness for contact with food and feedstuffs

See §5.1.3.4 of this ETA-Guideline, Part 1.

5.1.3.5 Air tightness

See §5.1.6.2 of this part of the ETA-Guideline.

5.1.3.6 Watertightness

Water leakage resistance of the building envelope, including driving rain on facades and possibly snow penetration, shall primarily be assessed by the approval body on the basis of the standard construction details for the building kit, and by using the available technical knowledge and experience from similar well-known technical solutions. The assessment must include the full external envelope, including joints between kit components and joints between the assembled kit and the substructure, where the latter are intended to provide weathertightness.

If the resistance against the effects of weather cannot be assessed by the use of existing knowledge, e.g. because of unfamiliar solutions to the relevant construction details, the approval body may find it necessary to require testing of the external envelope performance. Laboratory tests may be carried out according to EN 1027 (doors, gates and windows), EN 12865 (walls) and the ETA-Guideline 016.

5.1.4 Safety in use

5.1.4.1 Impact resistance

See §5.1.4.1 of this ETA-Guideline, Part 1.

5.1.4.2 Mechanical resistance

The mechanical resistance (and stability) of building kits is covered in §5.1.1. For building envelope kits (as far as applicable), the verification shall be performed in accordance with §5.1.1, but is usually limited to the mechanical resistance characteristics of the building envelope components (see §5.2.4, §5.3.4 and §5.4.4 of this part of the ETA-Guideline).

5.1.4.3 Resistance to eccentric loads

See §5.1.4.3 of this ETA-Guideline, Part 1.

5.1.4.4 Slipperiness of floor surfaces

The slipperiness of floor surfaces is being considered as a component requirement only (See §5.2.4.4 of this part of the ETA-Guideline).

5.1.4.5 Safety against personal injuries by contact

See §5.1.4.5 of this ETA-Guideline, Part 1.

5.1.4.6 Safety against entrapment

The safety against entrapment is being considered as a requirement, relevant for doors and gates only (See §5.3.4.6 of this part of the ETA-Guideline).

5.1.4.7 Safety against collapse

See §5.1.4.7 of this ETA-Guideline, Part 1.

5.1.4.8 Provisions preventing falling due to changes in level or drops

The Approval Body shall verify the design and the dimensions of any unprotected changes in floor level in the ETA. Where the kit includes stairs, guard rails, balustrades, barriers, etc at changes in level, drops or openings these shall be considered as a kit component. Reference can be made to ETAG 008 (for prefabricated stair kits) and to ISO/DIS 12055 (for other components).

5.1.5 Protection against noise

5.1.5.1 Airborne sound insulation

The airborne sound insulation performance (between rooms and of facades) of the main building parts of an assembled building shall be verified by laboratory tests, according to the relevant parts of EN ISO 140 (see table 5.2).

Table 5.2: Single-number quantities of airborne sound insulation properties

Single-number quantity	Term and symbol	Defined in
Weighted sound reduction index, R_w	Sound reduction index, R	EN ISO 140-3
Weighted suspended ceiling normalised level difference, $D_{n,c,w}$	Suspended-ceiling normalised level difference, $D_{n,c}$	EN 20140-9
Weighted element-normalised level difference, $D_{n,e,w}$	Element-normalised level difference, $D_{n,e}$	EN 20140-10

The rating of airborne sound insulation shall be undertaken according to EN ISO 717-1.

5.1.5.2 Impact sound insulation

The impact sound insulation performance of the floors of an assembled building shall be verified by laboratory tests according to EN ISO 140-6 (in accordance with table 5.3).

Table 5.3: Single-number quantities of impact sound insulation of floors

Single-number quantity	Term and symbol	Defined in
Weighted normalised impact sound pressure level, $L_{n,w}$	Normalised impact sound pressure level, L_n	EN ISO 140-6
Both EN ISO 140-8 and -11 can be used like EN ISO 140-6 to present single number ratings for the reduction of transmitted impact noise accomplished with floor coverings on a heavyweight and lightweight floor.		

The rating of impact sound insulation shall be undertaken according to EN ISO 717-2.

5.1.5.3 Sound absorption

Sound absorption shall be measured according to EN ISO 354.

5.1.6 Energy Economy and Heat Retention

5.1.6.1 Thermal performance

The thermal transmittance / resistance of the cold storage building or building envelope kit shall be determined on the basis of the thermal properties of its components (See §5.2.6.1, §5.3.6.1, §5.4.6.1 and §5.5.6 of this part of the ETA-Guideline).

If there is any discontinuity in the assembled system, such as the system frame, then the effect of thermal bridging shall be considered in accordance with EN ISO 10211-1, EN ISO 10211-2 and prEN ISO 14653.

5.1.6.2 Air permeability

See §5.1.6.2 of this ETA-Guideline, Part 1.

5.1.6.3 Water vapour permeability

The hygrothermal behaviour of the assembled kit is being assessed under ER3 (in §5.1.3.2 of this part of the ETA-Guideline).

5.1.6.4 Thermal inertia

Verification of the thermal inertia of assembled buildings is undertaken in accordance with EN 832 (or prEN 13790) on the basis of the following properties of the relevant building components which the approval body shall verify:

- the total mass per unit area (determined in accordance in the framework of §5.2.7.3, §5.3.7.3, §5.4.7.3 and §5.5.7.3 of this part of the ETA-Guideline)
- density (determined in accordance in the framework of §5.2.7.3, §5.3.7.3, §5.4.7.3 and §5.5.7.3 of this part of the ETA-Guideline or EN 1991-1-1, Annex A)
- specific heat capacity (in accordance with EN 12524 or determined in accordance with the appropriate product standards)
- thermal resistance (determined in the framework of §5.2.6.1, §5.3.6.1, §5.4.6.1 and §5.5.6.1 of this part of the ETA-Guideline).

5.1.7 Aspects of Durability, Serviceability and Identification

5.1.7.1 Durability

See §5.1.7.1 of this ETA-Guideline, Part 1.

5.1.7.2 Serviceability

See §5.1.7.2 of this ETA-Guideline, Part 1.

5.1.7.3 Identification

See §5.1.7.3 of part 1 of this ETA-Guideline and also §5.2.7.3, §5.3.7.3 and §5.4.7.3 of this part of the ETA-Guideline for the specified identification of kit components

In addition to the overview presented in the ETA-Guideline Part 1 (§5.1.7.3), the Approval body shall verify the following for profiles, framework, studs, etc:

- Nature of the profiles, framework, studs, ...: Classification in accordance with EN 10326, EN 10327, EN 10152, EN 10169-1 (for steel) or EN 573-3 (for aluminium).
- Dimensions with tolerances
- Shape

Note: These provisions only apply in case the components are part of the kit placed on the market by the ETA-applicant,

5.2 VERIFICATION METHODS RELEVANT FOR COMPONENTS: COMPOSITE PANELS

5.2.1 Mechanical Resistance and Stability

5.2.1.1 Impact resistance

The impact resistance is only relevant for assemblies (See §5.1.4.1 of this part of the ETA-Guideline) and doors and gates (See §5.3.4.1 of this part of the ETA-Guideline).

5.2.1.2 Mechanical resistance

5.2.1.2.1 Fixing resistance

See §5.2.4.2.1 of this ETA-Guideline, Part 1

5.2.1.2.2 Mechanical resistance of wall, ceiling and floor panels

Note: Unless the test methods referred to specify which panels should be tested, the most onerous composition (thickness of the faces and the thickness and density of the core) and the minimum and the maximum thickness shall be tested.

5.2.1.2.2.1 Mechanical resistance of wall panels

The following characteristics shall be determined:

- Axial load-bearing capacity: See Annex E of this ETA-Guideline, Part 1.
- Bending strength: See prEN 14509 or the relevant part of ETA-Guideline 016, depending on the nature of the panel
- Shear strength: See prEN 14509 or the relevant part of ETA-Guideline 016, depending on the nature of the panel

5.2.1.2.2.2 Mechanical resistance of ceiling panels

The following characteristics shall be determined:

- Bending strength: See prEN 14509 or the relevant part of ETA-Guideline 016, depending on the nature of the panel
- Shear strength: See prEN 14509 or the relevant part of ETA-Guideline 016, depending on the nature of the panel
- Compressive strength: See prEN 14509 or the relevant part of ETA-Guideline 016, depending on the nature of the panel
- Walkability: See prEN 14509 or the relevant part of ETA-Guideline 016, depending on the nature of the panel

5.2.1.2.2.3 Mechanical resistance of floor panels

5.2.1.2.2.3.1 Compressive strength

Floor panels shall be assessed in accordance with prEN 14509 or the relevant part of ETA-Guideline 016, depending on the nature of the panel

5.2.1.2.2.3.2 Concentrated load-bearing capacity

- Wood-based top face: the strength and stiffness under point load shall be determined according to EN 1195, in conjunction with EN 12871
- Metal top face: prEN 14509, the relevant part of ETA-Guideline 016, depending on the nature of the panel or CEN/TC134 standards (where relevant)

5.2.1.2.2.3.3 Resistance to rolling loads

Floor panels shall be assessed in accordance with Annex I of this ETA-Guideline.

5.2.1.2.2.4 Mechanical strength of pre-shaped panel intersections

See §5.2.4.2.2.3 of this ETA-Guideline, Part 1

5.2.1.2.3 Mechanical resistance of cold storage building envelopes

The mechanical resistance of cold storage building envelopes is only relevant for assemblies (See §5.1.4.2.3 of this part of the ETA-Guideline).

5.2.1.3 Resistance to eccentric loads

The resistance to eccentric loads is only relevant for assemblies (See §5.1.4.3 of this part of the ETA-Guideline).

5.2.2 Safety in case of Fire

5.2.2.1 Reaction to fire

See §5.2.2.1 of this ETA-Guideline, Part 1.

5.2.2.2 Fire resistance

Fire resistance testing is only relevant for assemblies (See §5.1.2.2 of this part of the ETA-Guideline). These components shall be tested as a part of the assembly.

5.2.2.3 External fire performance (of the roof covering)

External fire performance is covered in §5.1.2.3 of this part of the ETA-Guideline.

5.2.3 Hygiene, Health and the Environment

5.2.3.1 Release of dangerous substances

See §5.1.3.1 of this part of the ETA-Guideline. Additional provisions may be described in §5.2.3.1 of this ETA-Guideline, Part 1.

5.2.3.2 Water vapour permeability

See §5.2.3.2 of this ETA-Guideline, Part 1.

5.2.3.3 Moisture resistance

The moisture resistance is considered as a kit related requirement only, possibly leading to components needed to be tested (See §5.1.3.3 of this part of the ETA-Guideline).

5.2.3.4 Fitness for contact with food and feedstuffs

See §5.2.3.4 of this ETA-Guideline, Part 1.

5.2.3.5 Air tightness

The air tightness of the composite panel is being considered under ER6 (See §5.2.6.2 of this part of the ETA-Guideline).

5.2.3.6 Watertightness

Watertightness is covered in §5.1.3.6 of this part of the ETA-Guideline.

5.2.4 Safety in Use

5.2.4.1 General

The Essential Requirement 1 is not relevant for components of building envelope kits, but all characteristics covered under ER1 (see §5.2.1 of this part of the ETA-Guideline) are relevant for these building envelope kits under ER4.

5.2.4.2 Slipperiness of floor surfaces

See §5.2.4.4 of this ETA-Guideline, Part 1.

5.2.4.3 Safety against personal injuries by contact

The safety against personal injuries by contact is being considered as an assembly requirement only (See §5.1.4.5 of this part of the ETA-Guideline).

5.2.4.4 Safety against entrapment

The safety against entrapment is being considered as a requirement, relevant for doors and gates only (See §5.3.4.6 of this part of the ETA-Guideline).

5.2.4.5 Safety against collapse

The safety against collapse is being considered as an assembly requirement only (See §5.1.4.7 of this part of the ETA-Guideline).

5.2.5 Protection against Noise

5.2.5.1 Airborne sound insulation

Airborne sound insulation is covered in §5.1.5.1.

5.2.5.2 Impact sound insulation

Impact sound insulation is covered in §5.1.5.2.

5.2.5.3 Sound absorption

Sound absorption is covered in §5.1.5.3.

5.2.6 Energy Economy and Heat Retention

5.2.6.1 Thermal performance

See §5.2.6.1 of this ETA-Guideline, Part 1

5.2.6.2 Air permeability

See §5.2.6.2 of this ETA-Guideline, Part 1

5.2.6.3 Water vapour permeability

The hygrothermal behaviour of composite panels is being assessed under ER3 (in §5.2.3.2 of this part of the ETA-Guideline).

5.2.6.4 Thermal inertia

Thermal inertia is covered in §5.1.6.4 of this part of the ETA-Guideline.

5.2.7 Aspects of Durability, Serviceability and Identification

5.2.7.1 Durability

5.2.7.1.1 Panels:

See §5.2.7.1.1 of this ETA-Guideline, Part 1.

5.2.7.1.2 Faces:

See §5.2.7.1.2 of this ETA-Guideline, Part 1.

5.2.7.1.3 Coatings:

5.2.7.1.3.1. Resistance to humidity

The test shall be performed in accordance with EN ISO 6270 and shall have a duration as specified in table 5.4.

Table: 5.4: Resistance to humidity categories.

Category ⁸	I	II	III, IIIa, IV and IVb	V, Vc and VI
Duration (h)	None prescribed	500	1 000	1 500

5.2.7.1.3.2. Resistance to salt spray

The test shall be performed in accordance with EN 13523-8, using samples in accordance with option 1.

5.2.7.1.3.3. Resistance to the combined action of UV and condensation.

The artificial ageing test is performed for the categories III, IV, V and VI, in accordance with EN 13523-10, by exposing the samples to 150 cycles (total duration of 1 200 h) and using UV lamps A 340.

5.2.7.1.4 Floor finishes:

See §5.2.7.1.4 of this ETA-Guideline, Part 1.

5.2.7.2 Serviceability

5.2.7.2.1 Provisions related to the kit as a whole

Provisions related to the kit as a whole are given in §5.1.7.2.1 of this ETA-Guideline.

5.2.7.2.2 Provisions related to composite panels

Not all provisions foreseen in this paragraph are strictly speaking necessary to market kits for cold storage buildings. However, most ETA-applicants will foresee some or all of these aspects.

5.2.7.2.2.1 Performance characteristics of finishes

See §5.2.7.2.2.3 of this ETA-Guideline, Part 1.

5.2.7.2.2.2 Floor finishes:

See §5.2.7.2.2.4 of this ETA-Guideline, Part 1.

5.2.7.2.3 Provisions related to ancillary components of the kits

Provisions related to ancillary components are given in §5.1.7.2.3 of this ETA-Guideline.

⁸ See §7.5.5 for categories.

5.2.7.3 Identification

See §5.2.7.3 of this ETA-Guideline, Part 1.

5.3 VERIFICATION METHODS RELEVANT FOR COMPONENTS: DOORS, GATES AND WINDOWS, ROOF WINDOWS AND ROOFLIGHTS

Note 1: For Approval testing of cold storage room doors, gates and/or windows, approval bodies are recommended to use the following possibilities, to limit the amount of testing:

- results of sandwich panels assessment, which in some cases apply for doors and gates as well
- grouping, if for different doors or door configurations, the performance is identical
- extended application, if test results can be used for doors or door configurations that are known to have superior performance.

The Comprehension document contains recommended extended application rules. The issuing Approval body is responsible for applying these rules, as far as relevant and applicable.

Note 2: For power operated cold storage room doors and gates, products need to comply with compliance criteria for the Electromagnetic Compatibility (EMC) Directive 89/336/EEC and the Machinery Directive 98/37/EC, amended by Directive 98/79/EC, as specified in EN 13241-1, prEN 13241-2 or prEN 14351-1, -2 or -3.

5.3.1 Mechanical Resistance and Stability

This Essential Requirement is not relevant for components of cold storage building or building envelope kits.

Aspects of mechanical resistance and stability are being considered as part of "Safety in use" (see §5.3.4 of this part of the ETA-Guideline).

5.3.2 Safety in case of Fire

5.3.2.1 Reaction to fire

Testing of doors, gates and windows, roof windows and rooflights, with respect to reaction to fire shall be undertaken as described in prEN 14351-1, -2 or -3 (for doors, windows and roof windows), EN 1873 (for individual rooflights) or prEN 14963 (for continuous rooflights) or EN 13241-1 and prEN 13241-2 (for industrial doors and gates).

For doors, gates and windows, roof windows and rooflights, which are part of a cold storage building or building envelope kit, only the most onerous types should be subjected to reaction to fire testing. The test results would then be valid for the other, less onerous, door, gate and window types.

The decision about the most onerous door, gate and window type within a range of possibilities, which are specified in the ETA, needs to be taken in conjunction with a notified fire laboratory, notified for performing fire tests on doors, gates and windows, roof windows and rooflights in the framework of the CPD.

In case, the kit as a whole is subject to reaction to fire regulations, every door and gates and window type that is part of the ETA, needs to be subjected to the provisions for reaction to fire of the above mentioned product standards.

5.3.2.2 Fire resistance

See §5.3.2.2 of this ETA-Guideline, Part 1.

5.3.2.3 External fire performance (of the roof covering)

External fire performance is covered in §5.1.2.3.

5.3.3 Hygiene, Health and Environment

5.3.3.1 Release of dangerous substances

See §5.1.3.1 of this part of the ETA-Guideline. Additional provisions may be described in prEN 14351-1, -2 or -3 (for doors and windows and roof windows), EN 1873 (for individual rooflights) or prEN 14963 (for continuous rooflights) or EN 13241-1 and prEN 13241-2 (for industrial gates).

5.3.3.2 Water vapour permeability

See §5.3.3.2 of this ETA-Guideline, Part 1.

5.3.3.3 Moisture resistance

The moisture resistance is considered as a kit related requirement only, possibly leading to components needed to be tested (See §5.1.3.3 of this part of the ETA-Guideline).

5.3.3.4 Fitness for contact with food and feedstuffs

See §5.3.3.4 of this ETA-Guideline, Part 1.

5.3.3.5 Air tightness

The air tightness of doors, gates and windows, roof windows and rooflights is being considered under ER6 (in §5.3.6.2 of this part of the ETA-Guideline).

5.3.3.6 Watertightness

Watertightness is covered in §5.1.3.6 of this part of the ETA-Guideline.

5.3.4 Safety in Use

5.3.4.1 Impact resistance

See §5.3.4.1 of this ETA-Guideline, Part 1.

5.3.4.2 Mechanical resistance

5.3.4.2.1 Fixing resistance

The fixing resistance is only relevant for

- assemblies: see §5.1.4.2.1 of this part of the ETA-Guideline
- composite panels: see §5.2.4.2.1 of this part of the ETA-Guideline
- fixing systems: see §5.4.4.2.1 of this part of the ETA-Guideline

5.3.4.2.2 Mechanical resistance of wall, ceiling and floor panels

In cold storage buildings, doors, gates and windows, roof windows and rooflights are subjected to air pressure, caused by under pressure inside the buildings.

Tests on complete doors, gates and windows, roof windows and rooflights shall be carried out in accordance with EN 12211, but under the following conditions: 1200 Pa \pm 1 % for internal doors and gates and 2000 Pa \pm 1 % for external doors and gates. The deflection of fixed frame elements shall be determined by calculation or test.

5.3.4.2.3 Mechanical resistance of cold storage building envelopes

The mechanical resistance of cold storage building envelopes is only relevant for assemblies (See §5.1.4.2.3 of this part of the ETA-Guideline).

5.3.4.3 Resistance to eccentric loads

The resistance to eccentric loads is only relevant for assemblies (See §5.1.4.3 of this part of the ETA-Guideline).

5.3.4.4 Slipperiness of floor surfaces

Not relevant. The slipperiness of floor surfaces is being considered as a component requirement only (See §5.2.4.4 of this part of the ETA-Guideline).

5.3.4.5 Safety against personal injuries by contact

The safety against personal injuries by contact is being considered as an assembly requirement only (See §5.1.4.5 of this part of the ETA-Guideline).

5.3.4.6 Safety against entrapment

See §5.3.4.6 of this ETA-Guideline, Part 1.

5.3.4.7 Safety against collapse

The safety against collapse is being considered as an assembly requirement only (See §5.1.4.7 of this part of the ETA-Guideline).

5.3.5 Protection against Noise

5.3.5.1 Airborne sound insulation

Airborne sound insulation is covered in §5.1.5.1 of this part of the ETA-Guideline.

5.3.5.2 Impact sound insulation

Impact sound insulation is covered in §5.1.5.2 of this part of the ETA-Guideline.

5.3.5.3 Sound absorption

Sound absorption is covered in §5.1.5.3 of this part of the ETA-Guideline.

5.3.6 Energy Economy and Heat Retention

5.3.6.1 Thermal performance

See §5.3.6.1 of this ETA-Guideline, Part 1.

5.3.6.2 Air permeability

The product specifications shall be examined and performance in respect of air permeability assessed on the basis of known material properties, design details and the intended use, relevant to any energy conservation measures.

In general, testing of the air permeability of the components is considered unnecessary, because the air permeability of the assembled cold storage building is being assessed (See 5.1.6.2 of this part of the ETA-Guideline).

However, if testing is required, the air permeability of pedestrian doors, windows, roof windows and rooflights and panels with transparent surfaces, shall be determined in accordance with EN 1026, classification in accordance with EN 12207. For other doors and gates, verification in accordance with EN 12427, classification with EN 12426.

5.3.6.3 Water vapour permeability

The hygrothermal behaviour of doors, gates and windows, roof windows and rooflights is being assessed under ER3 (in §5.3.3.2 of this part of the ETA-Guideline).

5.3.6.4 Thermal inertia

Thermal inertia is covered in §5.1.6.4.

5.3.7 Aspects of Durability, Serviceability and Identification

5.3.7.1 Durability

See §5.3.7.1 of this ETA-Guideline, Part 1.

5.3.7.2 Serviceability

See §5.3.7.2 of this ETA-Guideline, Part 1.

5.3.7.2.3 Provisions related to ancillary components of the kits

Provisions related to ancillary components are given in §5.1.7.2.3 of this ETA-Guideline.

5.3.7.3 Identification

Usually, ETA-applicants will have acquired product certificates or test and/or classification reports for the kit components. In those cases, the approval body shall verify whether those documents are acceptable and still apply and introduce the relevant information in the ETA. Only if such is not available, the ETA-applicant shall determine the identification parameters as specified below.

In either case, the product certificates or test and/or classification reports shall be based on the determination methods as specified below or equivalent (in which case the ETA shall provide appropriate explanation).

Identification of doors and windows, roof windows and rooflights shall be performed in accordance with §5.1.7.3 and in prEN 14351-1, -2 or -3 (for doors and windows and roof windows), EN 1873 (for individual rooflights) or prEN 14963 (for continuous rooflights) or EN 13241-1 and prEN 13241-2 (for industrial gates).

In any case, dimensions (length, width, thickness), geometry (squareness, flatness, ...), significant properties (mechanical, physical, chemical, ...) and their tolerances shall be given.

5.4 VERIFICATION METHODS RELEVANT FOR COMPONENTS: FIXING SYSTEMS, SEALANTS, GASKETS AND BUILDING HARDWARE

5.4.1 Mechanical Resistance and Stability

This Essential Requirement is not relevant for components of cold storage building or building envelope kits.

Aspects of mechanical resistance and stability are being considered as part of “Safety in use” (see §5.4.4 of this part of the ETA-Guideline).

5.4.2 Safety in case of Fire

5.4.2.1 Reaction to fire

Not relevant for these components, unless the cold storage building or building envelope kit is subject to reaction to fire regulations.

In that case, the following shall apply:

5.4.2.1.1 Point fixing systems

These shall be tested as a part of a door set (See §5.3.2.1 of this part of the ETA-Guideline) or as part of the panel assembly (See §5.2.2.1 of this part of the ETA-Guideline). The fixing system shall also be tested as a part of the assembly in the fire resistance test (see §5.1.2.2 of this part of the ETA-Guideline). No reaction to fire classification shall be awarded.

5.4.2.1.2 Other components

See §5.4.2.1.2 of this ETA-Guideline, Part 1.

5.4.2.2 Fire resistance

Fire resistance testing is only relevant for assemblies (See §5.1.2.2 of this part of the ETA-Guideline). These components shall be assessed as a part of the assembly.

5.4.2.3 External fire performance (of the roof covering)

External fire performance is covered in §5.1.2.3 of this part of the ETA-Guideline.

5.4.3 Hygiene, Health and the Environment

5.4.3.1 Release of dangerous substances

See §5.1.3.1 of this part of the ETA-Guideline. Additional provisions may be described in:

- Fixing systems: ETA-Guideline 001
- Sealants: ETA-Guideline xx1 “Fire sealing and fire stopping products”
- Gaskets: No additional information available
- Building hardware: No additional information available

5.4.3.2 Water vapour permeability

See §5.4.3.2 of this ETA-Guideline, Part 1.

5.4.3.3 Moisture resistance

The moisture resistance is considered as a kit related requirement only, possibly leading to components needed to be tested (See §5.1.3.3 of this part of the ETA-Guideline).

5.4.3.4 Fitness for contact with food and feedstuffs

The susceptibility to the growth of harmful micro-organisms is being considered in accordance with §5.1.3.4 of this part of the ETA-Guideline.

5.4.3.4.1 Sealants

See §5.4.3.4.1 of this ETA-Guideline, Part 1.

5.4.3.4.2 Gaskets

See §5.4.3.4.2 of this ETA-Guideline, Part 1.

5.4.3.4.3 Building hardware – tracks and guides

See §5.4.3.4.3 of this ETA-Guideline, Part 1.

5.4.3.4.4 Building hardware - hinges

See §5.4.3.4.4 of this ETA-Guideline, Part 1.

5.4.3.4.5 Fixing systems

See §5.4.3.4.5 of this ETA-Guideline, Part 1.

5.4.3.5 Air tightness

The air tightness is being considered under ER6 (in §5.4.6.2 of this part of the ETA-Guideline).

5.4.3.6 Watertightness

Watertightness is covered in §5.1.3.6 of this part of the ETA-Guideline.

5.4.4 Safety in Use

5.4.4.1 Impact resistance

Not relevant for these components. They shall be assessed as a part of the assembly (See §5.1.4.1 of this part of the ETA-Guideline).

5.4.4.2 Mechanical resistance

5.4.4.2.1 Fixing resistance

The fixing resistance is only relevant assemblies (See §5.1.4.2.1 of this part of the ETA-Guideline), composite panels (See §5.2.4.2.1 of this part of the ETA-Guideline) and fixing systems. It is not relevant for sealants, for gaskets, nor for building hardware.

If sufficient evidence is not available from tests performed in accordance with §5.1.4.2.1 and §5.2.4.2.1 of this part of the ETA-Guideline, then verification in accordance with UEAtc-Guide M.O.A.T. No. 59:1996, §3.1.5, EN 1993-1-8 or prEN 14592, is possible.

However, particularities of the fixing system may necessitate alterations to the test set-up. Determination of a representative sample and test set-up is carried out by the approval body in co-operation with the ETA-applicant and is based on the experience of the approval body.

5.4.4.2.2 Mechanical resistance of wall, ceiling and floor panels

The mechanical resistance of wall, ceiling and floor panels is only relevant for composite panels (See §5.2.4.2.2 of this part of the ETA-Guideline).

5.4.4.2.3 Mechanical resistance of cold storage building envelopes

The mechanical resistance of cold storage envelopes is only relevant for assemblies (See §5.1.4.2.3 of this part of the ETA-Guideline).

5.4.4.3 Resistance to eccentric loads

Not relevant for these components. They shall be assessed as a part of the assembly (See §5.1.4.3 of this part of the ETA-Guideline).

5.4.4.4 Slipperiness of floor surfaces

Not relevant. The slipperiness of floor surfaces is being considered as a component requirement only (See §5.2.4.4 of this part of the ETA-Guideline).

5.4.4.5 Safety against personal injuries by contact

The safety against personal injuries by contact is being considered as an assembly requirement only (See §5.1.4.5 of this part of the ETA-Guideline).

5.4.4.6 Safety against entrapment

The safety against entrapment is being considered as a requirement, relevant for doors and gates only (See §5.3.4.6 of this part of the ETA-Guideline).

5.4.4.7 Safety against collapse

The safety against collapse is being considered as an assembly requirement only (See §5.1.4.7 of this part of the ETA-Guideline).

5.4.5 Protection against Noise

5.4.5.1 Airborne sound insulation

Airborne sound insulation is covered in §5.1.5.1 of this part of the ETA-Guideline.

5.4.5.2 Impact sound insulation

Impact sound insulation is covered in §5.1.5.2 of this part of the ETA-Guideline.

5.4.5.3 Sound absorption

Sound absorption is covered in §5.1.5.3 of this part of the ETA-Guideline.

5.4.6 Energy Economy and Heat Retention

5.4.6.1 Thermal performance

See §5.4.6.1 of this ETA-Guideline, Part 1.

5.4.6.2 Air permeability

Not relevant for these components. They shall be assessed as a part of the assembly (See §5.1.6.2 of this part of the ETA-Guideline).

5.4.6.3 Water vapour permeability

The hygrothermal behaviour is being assessed under ER3 (in §5.4.3.2 of this part of the ETA-Guideline).

5.4.6.4 Thermal inertia

Thermal inertia is covered in §5.1.6.4 of this part of the ETA-Guideline.

5.4.7 Aspects of Durability, Serviceability and Identification

5.4.7.1 Durability

See §5.4.7.1 of this ETA-Guideline, Part 1.
Additionally, the exposure to external conditions needs to be taken into account.

5.4.7.2 Serviceability

5.4.7.2.1 Provisions related to the kit as a whole

Provisions related to the kit as a whole are given in §5.1.7.2.1 of this part of the ETA-Guideline.

5.4.7.2.2 Provisions related to fixing systems, sealants, gaskets and building hardware

Not all provisions foreseen in this paragraph are strictly speaking necessary to market cold storage building or building envelope kits. However, most ETA-applicants will foresee some or all of these aspects.

5.4.7.2.2.1 Fixing systems

No particular requirements.

5.4.7.2.2.2 Sealants

See §5.4.7.2.2.2 of this ETA-Guideline, Part 1.

5.4.7.2.2.3 Gaskets

5.4.7.2.2.3.1 Resistance to changes in temperatures

In this test, the product is subjected to accelerated ageing. Before and after ageing, the test specimens are subjected to compression deformation, and the resulting deterioration judged.

The product shall be introduced in an assembly of two rectangular tubes, made of aluminium in accordance with EN 755-1, of approximately 0,2 m length, which are mounted parallel to the length of the joint (see figure 1). Between the product and one of the rectangular tubes a separating foil shall be arranged, preventing adherence between the product and the tube. The sealant sample width should correspond with its maximum width in its intended use.

After conditioning in laboratory conditions during 7 days, one test specimen shall be subjected three times to the following artificial exposure cycle:

For products intended to be exposed to external environments:

- (a) (22 ± 1) h at (50 ± 2) °C
- (b) (120 ± 5) min at (80 ± 2) °C.
- (c) (22 ± 1) h at (50 ± 2) °C
- (d) (120 ± 5) min at (80 ± 2) °C.
- (e) (24 ± 1) h immersion in distilled water at (23 ± 2) °C
- (f) (72 ± 1) h exposure in a freezer at $(t \pm 2)$ °C

For products not intended to be exposed to external environments:

- (a) (48 ± 1) h at (50 ± 2) °C
- (b) (24 ± 1) h immersion in distilled water at (23 ± 2) °C
- (c) (72 ± 1) h exposure in a freezer at $((t-2) \pm 2)$ °C

Where "t" is the extreme negative temperature, in accordance with the ETA-applicant's specifications (e.g. -20°C, -25°C, -30°C or -40°C).

Subsequently the test specimen shall be stored one additional day at laboratory conditions. Then the contact surface(-s) shall be visually inspected for discolouring (naked eye) and drifting of adhesive. The remaining compression deformation of the product shall be determined in accordance with EN ISO 1856.

For products used externally, exposed to driving rain, or if the ETA-applicant claims driving rain tightness, the product shall be tested in accordance with EN 1027, method 1A. A test specimen shall be made with three longitudinal joints for the test. The product shall be installed between $(1,1 \pm 0,1)$ m long rectangular tubes of aluminium, in accordance with EN 755-1, which are mounted parallel to the width of the joint (see figure 2).

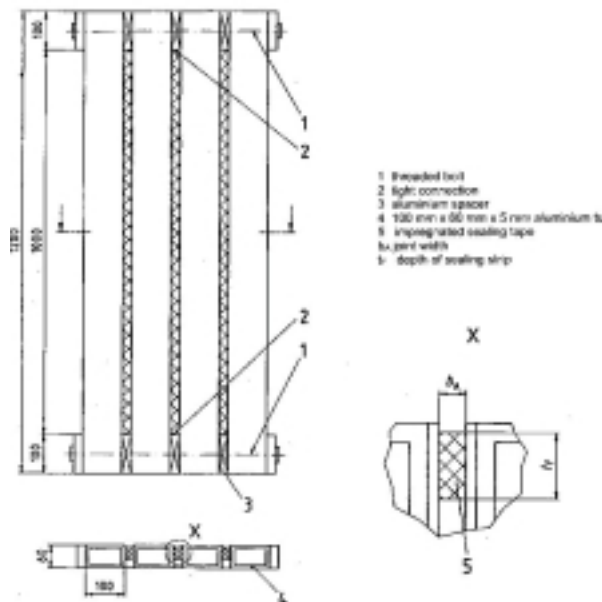

Figure 1: Assembly for testing resistance to temperature fluctuations

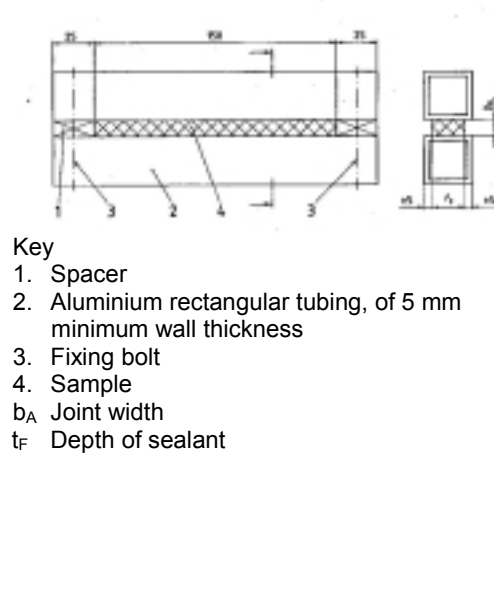

Figure 2: Assembly for testing tightness to driving rain of joints

5.4.7.2.2.3.2 Resistance to UV radiation

This test is only relevant for products intended to be exposed to UV radiation. The product is subjected to artificial light and moisture exposure in accordance with EN ISO 4892-2. The exposure shall be in accordance with ISO 11431, conditioning method B.

Subsequently the test specimen shall be stored one additional day at laboratory conditions. Then the contact surface(-s) shall be visually inspected for discolouring (naked eye) and drifting of adhesive.

The remaining compression deformation of the product shall be determined in accordance with EN ISO 1856.

For products used externally, exposed to driving rain, or if the ETA-applicant claims driving rain tightness, the product shall be tested in accordance with EN 1027, method 1A. A test specimen shall be made with three longitudinal joints for the test. The product

shall be installed between $(1,1 \pm 0,1)$ m long rectangular tubes of aluminium, in accordance with EN 755-1, which are mounted parallel to the width of the joint (see figure 2).

5.4.7.2.2.3.3 *In service temperature range*

See §5.4.7.2.2.3.2 of this ETA-Guideline, Part 1.

5.4.7.2.2.4 *Building hardware*

No particular requirements.

5.4.7.2.3 Provisions related to ancillary components of the kits

Provisions related to ancillary components are given in §5.1.7.2.3 of this part of the ETA-Guideline.

5.4.7.3 *Identification*

See §5.4.7.3 of this ETA-Guideline, Part 1.

5.5 VERIFICATION METHODS FOR COMPONENTS: PROFILES, FRAMEWORK, STUDS, ETC.

5.5.1 Mechanical resistance and stability (for building kits only)

5.5.1.1 General

The load-bearing capacity and suitability of the supporting framework of a kit shall be determined taking account of EN 1990 either by calculation, testing or a combination of calculation assisted by testing (see clauses 5.5.4.1.2 or 5.5.4.1.3).

However, usually, the supporting framework has no load-bearing function and only transmits loads onto structural elements (e.g. floors, walls).

In such cases, the mechanical resistance of the supporting framework may be considered satisfactory, if the assembly tests required in this ETA-Guideline (e.g. SBI, resistance to fire, impact resistance) have been performed with satisfactory result.

Extended application and engineering knowledge may be used to verify supporting framework, profiles, etc. that are made out of the same material and have comparable intended use(-s).

5.5.1.2 Calculation

The additional supporting framework shall be calculated in accordance with the following, depending upon the materials used:

- EN 1993: Design of steel structures
- EN 1999: Design of aluminium structures

5.5.1.3 Testing

Where the additional supporting framework cannot be calculated or where a testing approach is preferred, the profiles are tested on a case-by-case approach, taking into account the particular design and intended use.

5.5.2 Safety in case of fire

5.5.2.1 Reaction to fire

Generally, one or more of the following options shall apply. However, certain end use applications of some products may not be able to be satisfactorily classified using EN 13501-1 (e.g. facades).

Option 1: The supporting framework shall be tested, using the test method(s) relevant for the corresponding reaction to fire class, in order to be classified according to EN 13501-1. Mounting and fixing provisions are given in the relevant product specification.

Option 2: If the supporting framework is considered to satisfy the requirements for performance Class A1 of the characteristic reaction to fire, in accordance with the provisions of EC Decision 96/603/EC (as amended) without the need for testing on the basis of its listing in that Decision.

5.5.3 Hygiene, health and the environment

5.5.3.1 Release of dangerous substances

See §5.1.3.1 of this part of the ETA-Guideline.

5.5.4 Safety in use – Mechanical resistance (for room and building envelope kits only)

See §5.5.1.

5.5.5 Protection against noise

Not relevant to this component

5.5.6 Energy economy and heat retention

Usually, the ETA-applicant will allow EN 12524 to be used to determine the thermal resistance of the supporting framework.

Where a manufacturer makes specific claims for the thermal performance of a fire protective board kit, the thermal characteristics of the frame members shall be determined using relevant tests and calculations, e.g. given in EN 12412-2 and EN ISO 10077-2.

5.5.7 Aspects of durability, serviceability and identification

5.5.7.1 Durability and serviceability requirements

If supporting profiles or a framework are components of the kit, then these shall also be assessed, with regard to durability and serviceability, on the basis of European (CEN) or International standards (ISO). Because such components can be designed in a large number of possibilities and materials, the assessment method shall be considered on a case-by-case basis, taking into account that a number of verification methods already foresee the incorporation of these components in a number of assembly tests (e.g. SBI, fire resistance, impact resistance).

In order to demonstrate the durability and serviceability of supporting framework, the approval body may make use of information derived from documented sources, such as listed experience, previous approval procedures etc. The file must make clear under what conditions of climate and product usage the satisfactory experience has been gained.

The following references shall be used for aluminium, steel or timber supporting framework:

Aluminium

The corrosion protection of aluminium supporting framework shall be classified in accordance with EN 1396 or EN 573-3.

Steel

The corrosion protection of steel supporting framework shall be classified in accordance with EN 10327 or EN 10152. Coating of steel parts with zinc compatible organic coating shall be verified according to EN ISO 12944-3 (paints, coatings) or with equivalent coil coating according to EN 10169-1.

Unplasticised polyvinyl chloride

White PVC-U extrusions may be assessed against the requirements of EN 12608. For dark coloured profiles (through-coloured, capped or foiled) additional requirements must be taken into account. The effect of temperature is particularly important – see also 5.2.1.3. The UEAtc document *Technical Report on the Assessment of Windows in Coloured PVC-U* provides further guidance.

5.5.7.2 Identification

The Approval body shall verify the following:

- Nature of the profiles, framework, studs, ...: Classification in accordance with EN 10326, EN 10327, EN 10152, EN 10169-1 (for steel) or EN 573-3 (for aluminium).
- Dimensions with tolerances
- Shape

6. ASSESSING AND JUDGING OF THE FITNESS FOR USE OF PRODUCTS FOR AN INTENDED USE

This Chapter details the performance requirements to be met by a kit for prefabricated cold storage building envelope and building (chapter 4) into precise and measurable criteria (as far as possible and proportional to the importance of the risk) or qualitative terms, related to the products and their intended use, using the outcome of the verification methods (chapter 5).

The possible ways of expressing the results of the assessment of the mandatory performance requirements are shown in the following table 6.1:

Table 6.1 Ways of expressing the results of the assessment of the mandatory performance requirements

ER	ETAG paragraph on product performance	ETAG paragraph on assessment and judgement of product characteristics		NPD allowed
		Kits	Components	
1	Mechanical resistance and stability	§6.1.1	§6.2.1, §6.3.1, §6.4.1 and §6.5.1	No**
2	Reaction to fire	§6.1.2.1	§6.2.2.1, §6.3.2.1, §6.4.2.1 and §6.5.2.1	Yes
	Fire resistance	§6.1.2.2	§6.2.2.2, §6.3.2.2 and §6.4.2.2	Yes
	External fire performance	§6.1.2.3	§6.2.2.3, §6.3.2.3 and §6.4.2.3	Yes
3	Release of dangerous substances	§6.1.3.1	§6.2.3.1, §6.3.3.1, §6.4.3.1 and §6.5.3.1	Yes
	Vapour permeability	§6.1.3.2	§6.2.3.2, §6.3.3.2 and §6.4.3.2	Yes
	Moisture resistance	§6.1.3.3	§6.2.3.3, §6.3.3.3 and §6.4.3.3	Yes
	Fitness for contact with food and feedstuffs	§6.1.3.4	§6.2.3.4, §6.3.3.4 and §6.4.3.4	Yes ⁹
	Air tightness	§6.1.3.5*	§6.2.3.5, §6.3.3.5 and §6.4.3.5*	Yes
	Water tightness	§6.1.3.6	§6.2.3.6, §6.3.3.6 and §6.4.3.6	Yes
4	Impact resistance	§6.1.4.1	§6.2.1.1, §6.3.4.1 and §6.4.4.1	Yes
	Mechanical resistance	§6.1.4.2	§6.2.1.2, §6.3.4.2, §6.4.4.2 and §6.5.4	Yes
	Resistance to eccentric loads	§6.1.4.3	§6.2.1.3, §6.3.4.3 and §6.4.4.3	Yes
	Slipperiness (floors)	§6.1.4.4	§6.2.4.2, §6.3.4.4 and §6.4.4.4	Yes
	Safety against personal injury	§6.1.4.5	§6.2.4.3, §6.3.4.5 and §6.4.4.5	Yes
	Safety against entrapment	§6.1.4.6	§6.2.4.4, §6.3.4.6 and §6.4.4.6	No
	Safety against collapse (due to air pressure differences)	§6.1.4.7	§6.2.4.5, §6.3.4.7 and §6.4.4.7	No ¹⁰
	Provisions preventing falling due to changes in level or drops	§6.1.4.8	-	No
5	Airborne sound insulation	§6.1.5.1	§6.2.5.1, §6.3.5.1 and §6.4.5.1	Yes
	Impact sound insulation	§6.1.5.2	§6.2.5.2, §6.3.5.2 and §6.4.5.2	Yes
	Sound absorption	§6.1.5.3	§6.2.5.3, §6.3.5.3 and §6.4.5.3	Yes
6	Thermal resistance	§6.1.6.1	§6.2.6.1, §6.3.6.1, §6.4.6.1 and §6.5.6	No
	Air permeability	§6.1.6.2	§6.2.6.2, §6.3.6.2 and §6.4.6.2	Yes
	Water vapour permeability	§6.1.6.3*	§6.2.6.3, §6.3.6.3 and §6.4.6.3*	Yes
	Thermal inertia	§6.1.6.4	§6.2.6.4, §6.3.6.4 and §6.4.6.4	Yes
	Durability	§6.1.7.1	§6.2.7.1, §6.3.7.1, §6.4.7.1 and §6.5.7.1	No
	Serviceability	§6.1.7.2	§6.2.7.2, §6.3.7.2 and §6.4.7.2	Yes
	Identification	§6.1.7.3	§6.2.7.3, §6.3.7.3, §6.4.7.3 and §6.5.7.1	No

* Characteristics added for completeness. Cross references have been made between ER3 and ER6

** NPD is not allowed for cold storage building kits; the characteristic is not relevant for cold storage building envelope kits.

⁹ The "No Performance Determined" option is not allowed under conditions specified in clause 6.1.3.4 (see also §6.2.3.4, §6.2.7.2.2.3.4, §6.2.7.2.2.3.5, §6.3.3.4 and §6.4.3.4) of this ETA-Guideline, Part 1.

¹⁰ Unless the intended use of the kit is limited to a temperature range above 0°C.

Note: The general rule, when considering the cases where the “NPD” (No Performance Determined) option should not be allowed, is that NPD should always be allowed, if there is at least one EEA Member State that does not have a regulatory requirement for the characteristic under consideration. The one derogation from that general rule is that ETA-Guidelines have the possibility to not allow NPD in those cases where the characteristic almost defines the product (e.g. water tightness for a waterproofing membrane).

The WG has decided to not allow NPD in the following cases:

- Thermal resistance, because this is a vital characteristic of a cold storage building envelope and building
- Safety against entrapment and against collapse due to air pressure differences, because these are characteristics that might lead to loss of life, if not present or not functioning properly.
- Provisions preventing falling due to changes in level or drops, for building kits with such components, because the fitness for use of these provisions are crucial for safety.

For durability, serviceability and identification, NPD is not an option, as far as:

- durability is related to components that are part of the kit and as far as relevant for the intended use of the kit and for (a) performance(-s) declared in the ETA
- identification is related to components that are part of the kit

6.1 ASSESSING AND JUDGING OF THE FITNESS FOR USE OF THE KIT / ASSEMBLED SYSTEM

6.1.1 Mechanical Resistance and Stability

6.1.1.1. Indication of geometrical data

The ETA shall include at least the following information:

- the geometrical data (dimensions and cross sections, including tolerances) of the structural kit components and of the assembled kit
- the properties of the materials and constituent products used that are needed to determine, according to the National Provisions, valid in the place of use, or possible use, load-bearing capacities and other properties, including aspects of durability and serviceability, of the assembled kit installed in the works, as far as possible.

If assistance through testing has been used to accompany geometrical data, the tests performed and the test results shall be specified with sufficient detail.

6.1.1.2 Verification by calculation with or without assistance through testing

6.1.1.2.1 General

The properties of structural components related to "mechanical resistance and stability" should be specified in the ETA with regard to the needs of fulfilling National Provisions.

This may be done by expressing the properties in terms of:

- characteristic values for strength and other cross section properties from which the load-bearing capacities of the assembled kit installed in the works, taking into account the National Provisions, can be calculated, or
- design values provided that the Nationally Determined Parameters (NDP) applicable to works have been taken into account by appropriate levels and classes, which correspond to sets of NDPs.

Notes

1. Each declared value shall correspond, as far as practicable, to a defined statistical confidence (defined fractile and confidence level).
To express a property by the "design value" involves that the set of applicable NDPs are expressed in the ETA in terms of classes. For this purpose, the classes shall be defined in the ETA by the combination of NDPs applicable in Member States. Normally, for a given structural component and its intended use:
 - a number of symbols, classes or alternative methods, which in Eurocodes have the status of NDPs, will not be relevant, and
 - the relevant NDPs will not always be different from one Member State to the other.
This means that, in most cases, a reduced number of classes in the ETA will be sufficient to cover the NDPs and the differences of NDPs in the various Member States.
2. Possibly, in particular cases, it may happen that there is just one set of NDPs to be taken into account in the ETA, which covers the end use conditions in all the Member States.

Each ETA shall state that for each individual project, calculations for the mechanical resistance and stability of the structure should be made, taking into account the National Provisions.

Note: All methods presented in EC Guidance paper L are available for Approval Bodies, but NDPs used in calculations shall always be specified in the ETA. Providing more than geometrical data and properties (see §6.1.4.2.1, i.e. method 1 of EC Guidance paper L) is a possibility, it is not an obligation. If the ETA-applicant only places the product covered in the ETA in one country, the ETA will need to specify the design values and NDPs for that country. If the ETA-applicant places the product covered by the ETA in more than one country, he will need to provide various design values, using the various sets of NDPs.

6.1.1.2.2 Structural capacities

6.1.1.2.2.1 Internal (load-bearing) walls

The following design resistances for internal walls shall normally be declared:

- Vertical resistance in kN/m
- Racking resistance in kN/m for instantaneous loads, assuming that studs are effectively anchored to the substructure

6.1.1.2.2.2 (Suspended) floors

The following design resistances for suspended floors shall normally be declared:

- Net vertical uniformly distributed medium-term imposed floor load resistance in kN/m² as defined in EN 1991-1-1
- Vertical local concentrated medium-term imposed floor load resistance in kN as defined in EN 1991-1-1
- Horizontal diaphragm shear resistance in kN/m at ultimate limit state for instantaneous load

6.1.1.2.2.3 Ceiling structures

The following design resistances for roof structures shall normally be declared:

- Maximum uniformly distributed vertical medium-term, short-term and instantaneous load resistance in kN/m²
- Vertical local concentrated short-term imposed roof load resistance in kN as defined in EN 1991-1-1
- Horizontal diaphragm shear resistance in kN/m at ultimate limit state for instantaneous load
- Vertical and horizontal anchorage resistances of standard roof structure fixings at ultimate limit state for instantaneous loads, when such fixings are part of the kit or unit.

Notes:

1. Vertical load-carrying resistances for wall structures may include openings for windows and doors and gates when the kit or unit has standard openings with specified dimensions, and standard load-carrying components around the openings.
2. Racking load resistances are normally declared only for wall sections without openings. The racking load should normally also be declared on the basis that vertical uplift of walls are prevented by separate anchors designed for each individual works.
3. Resistances against instantaneous and short-term loads for ceilings shall normally be declared separately. On request from the ETA-applicant, specified combinations (with a specified wind load action) may also be declared.
4. Densities and total mass necessary for the calculation of seismic forces should also be declared when relevant for the intended use (geographical zones). Assessment of the seismic resistance of buildings is otherwise assumed to be possible to be undertaken on the basis of the declared racking resistance and diaphragm shear capacities for the kit or unit, and also the anchorage capacities of fixings when relevant.
5. In France, the fixing resistance of suspension fixings shall be at least 4500 N.

6.1.1.2.3 Resistance against seismic actions

Load-bearing capacities of the main building parts and anchorage, including racking resistance and horizontal diaphragm shear load capacity, is covered by §6.1.1.2.2. If a building or building envelope kit is to be put on the market in areas with seismic zones, the masses of the building or building envelope kit components shall be declared, as well as the specific characteristics of connections and factors for energy dissipation according to the methods of calculation given in §5.1.1.3.

6.1.1.2.4 Structural analysis

The detailed structural analysis to verify the declared capacities mentioned in §6.1.1.2.2 and §6.1.1.2.3 shall always be available to the approval body as a part of the technical file for the ETA.

6.1.2 Safety in case of Fire

6.1.2.1 Reaction to fire

Components of cold storage building or building envelope kits shall be classified in accordance with EN 13501-1 (see §6.2.2.1, §6.3.2.1, §6.4.2.1 and §6.5.2.1 of this part of the ETA-Guideline).

6.1.2.2 Fire resistance

See §6.1.2.2 of this ETA-Guideline, Part 1.

6.1.2.3 External fire performance (of the roof covering)

The cold storage building or building envelope kit components, or the assembled system of which the component may form part of, shall be classified according to EN 13501-5.

6.1.3 Hygiene, Health and the Environment

6.1.3.1 Release of dangerous substances

See §6.1.3.1 of this ETA-Guideline, Part 1.

6.1.3.2 Water vapour permeability

See §6.1.3.2 of this ETA-Guideline, Part 1.

6.1.3.3 Moisture resistance

See §6.1.3.3 of this ETA-Guideline, Part 1.

6.1.3.4 Fitness for contact with food and feedstuffs

See §6.1.3.4 of this ETA-Guideline, Part 1.

6.1.3.5 Air tightness

The air tightness of the assembled kit is being considered under ER6 (in §6.1.6.2 of this part of the ETA-Guideline).

6.1.3.6 Watertightness

The performance of the building shall normally have to be declared in qualitative terms in relation to the intended use like potential climatic zones, and with respect to durability aspects (see EC Guidance Paper F on Durability and the Construction Products Directive), as well as to the requirements mentioned in chapter 4. When a building is assessed to be inadequate in certain regions (for example in areas with exceptional amounts of driving rain or potential snow penetration), the limitations on the intended use must be clearly stated in the ETA.

In case tests have been performed, the test results shall be declared.

6.1.4 Safety in Use

6.1.4.1 Impact resistance

See §6.1.4.1 of this ETA-Guideline, Part 1.

6.1.4.2 Mechanical resistance

The mechanical resistance (and stability) of building kits is covered in §6.1.1 of this part of the ETA-Guideline. For building envelope kits (as far as applicable), the assessment shall be performed in accordance with §5.1.1 of this part of the ETA-Guideline, but is usually limited to the mechanical resistance characteristics of the building envelope components (see §5.2.4, §5.3.4, §5.4.4, and §5.5.4 of this part of the ETA-Guideline).

6.1.4.3 Resistance to structural damage from eccentric vertical load

See §6.1.4.3 of this ETA-Guideline, Part 1.

6.1.4.4 Slipperiness of floor surfaces

The slipperiness of floor surfaces is being considered as a component requirement only (See §6.2.4.4 of this part of the ETA-Guideline).

6.1.4.5 Safety against personal injuries by contact

See §6.1.4.5 of this ETA-Guideline, Part 1.

6.1.4.6 Safety against entrapment

The safety against entrapment is being considered as a requirement, relevant for doors and gates only (See §6.3.4.6 of this part of the ETA-Guideline).

6.1.4.7 Safety against collapse

See §6.1.4.7 of this ETA-Guideline, Part 1.

6.1.4.8 Provisions preventing falling due to changes in level or drops

The Approval Body shall assess and judge the design and the dimensions of any unprotected changes in floor level and shall specify these in the ETA. Where the kit includes stairs, guard rails, balustrades, barriers, etc at changes in level, drops or openings these shall be assessed and judged as a kit component. Reference can be made to ETAG 008 (for prefabricated stair kits) and to ISO/DIS 12055 (for other components).

Note: Attention is drawn to the fact that in certain countries additional/different requirements may be applicable due to existing national regulations or the equivalent for the works.

6.1.5 Protection against Noise

6.1.5.1 Airborne sound insulation

The airborne sound insulation between rooms and of facades shall be declared in the ETA, in accordance with EN ISO 717-1.

Other designations mentioned in EN ISO 717-1 may be added in the approval, to agree with the verification methods according to national building regulations based on such designations.

6.1.5.2 Impact sound insulation

The impact sound insulation for floors shall be declared in the ETA in accordance with EN ISO 717-2.

Other designations mentioned in EN ISO 717-2 may be added in the approval, to agree

with the verification methods according to national building regulations based on such designations.

6.1.5.3 Sound absorption

The sound absorption rating of internal surfaces shall be declared in accordance with EN ISO 11654.

6.1.6 Energy Economy and Heat Retention

6.1.6.1 Thermal performance

The thermal transmittance / resistance of the components (See §6.2.6.1, §6.3.6.1, §6.4.6.1 and §6.5.6.1 of this part of the ETA-Guideline) of the cold storage building or building envelope kit shall be declared.

6.1.6.2 Air permeability

See §6.1.6.2 of this ETA-Guideline, Part 1.

6.1.6.3 Water vapour permeability

The hygrothermal behaviour of the assembled kit is being assessed under ER3 (in §6.1.3.2 of this part of the ETA-Guideline).

6.1.6.4 Thermal inertia

For relevant components, the information on:

- total mass per unit area
- density,
- specific heat capacity
- thermal resistance

shall be declared as a means for the designer to calculate the project dependent thermal inertia of the building in accordance with EN 832 (or prEN 13790).

6.1.7 Aspects of Durability, Serviceability and Identification

6.1.7.1 Durability

See §6.1.7.1 of this ETA-Guideline, Part 1.

6.1.7.2 Serviceability

See §6.1.7.2 of this ETA-Guideline, Part 1.

6.1.7.3 Identification

See §6.1.7.3 of this ETA-Guideline, Part 1.

6.2 ASSESSING AND JUDGING OF THE FITNESS FOR USE OF COMPONENTS OF THE KIT: COMPOSITE PANELS

6.2.1 Mechanical Resistance and Stability

6.2.1.1 Impact resistance

The impact resistance is only relevant for assemblies (See §6.1.4.1 of this part of the ETA-Guideline) and doors and gates (See §6.3.4.1 of this part of the ETA-Guideline).

6.2.1.2 Mechanical resistance

6.2.1.2.1 Fixing resistance

See §6.1.7.1 of this ETA-Guideline, Part 1.

6.2.1.2.2 Mechanical resistance of wall, ceiling and floor panels

6.2.1.2.2.1 Mechanical resistance of wall panels

On the basis of the verification method, specified in §5.2.4.2.2.1 of this part of the ETA-Guideline, the axial load-bearing capacity and the bending and shear strength shall be declared in the ETA.

In the ETA, extended application of the test results (if any) shall be declared, under the responsibility of the Approval Body.

6.2.1.2.2.2 Mechanical resistance of ceiling panels

On the basis of the verification method, specified in §5.2.4.2.2.2 of this part of the ETA-Guideline, the bending, shear and compressive strength and walkability (see table 6.2) shall be declared in the ETA.

In the ETA, extended application of the test results (if any) shall be declared, under the responsibility of the Approval Body.

Table 6.2: Roof/ceiling walkability use category criteria

Use categories	Level of walkability	Impact resistance		Walkability
		Hard body impact	Soft body impact	
A1	Not accessible roofs/ceilings (not even for installation)	None	NPD or Fail	NPD or fail
A2	Roofs/ceilings, accessible for installation and maintenance only (always with protective measures)	ER4: - Serv.: 1 x 5 Nm	ER4: 1 x 1200 Nm Serv.: 1x700 Nm	NPD or fail (visible damage)
A3	Roofs/ceilings, accessible with protective measures	ER4: - Serv.: 1 x 10 Nm	ER4: 1 x 1200 Nm Serv.: 5x700 Nm	NPD or fail (visible damage)
A4	Roofs/ceilings, accessible without protective measures	ER4: - Serv.: 1 x 10 Nm	ER4: 1 x 1200 Nm Serv.: 5x700 Nm	Pass

Note: For the definition of "walkability" see §2.2.

6.2.1.2.2.3 Mechanical resistance of floor panels

6.2.1.2.2.3.1 Compressive strength

Floor panels shall be assessed in accordance with prEN 14509

6.2.1.2.2.3.2 Concentrated load-bearing capacity

Having been tested in accordance with §5.2.4.2.2.3.2 of this part of the ETA-Guideline,

the test results shall be declared.

6.2.1.2.2.3.3 Resistance to rolling loads

Floor coverings, tested for resistance to rolling loads, with or without floor panels (only in case the floor panels are not part of the kit), shall be classified in accordance with table 6.3. The products shall be classified in accordance with the lowest level obtained for one of the characteristics.

Table 6.3: Classification for rolling load resistance

Classification	Resistance to Impact	Resistance to perforation	Skid resistance	Resistance to abrasion
Level 1	I ₁	P ₁	S ₁	A ₁
Level 2	I ₂	P ₂	S ₂	A ₂
Level 3	I ₃	P ₃	S ₃	A ₃
Level 4	I ₄	P ₄	S ₄	A ₄

Table 6.4: Correspondence of the classification for rolling load resistance with acceptable rolling loads.

Classification	Corresponding acceptable rolling loads (kg/tyre)	
	Hard tyres	Soft (pneumatic) tyres
Level 1	≤ 300 kg	≤ 1 ton
Level 2	≤ 1 ton	≤ 2 ton
Level 3	≤ 2 ton	≤ 4 ton
Level 4	> 2 ton	> 4 ton

6.2.1.2.2.4 Mechanical strength of pre-shaped panel intersections

See §6.2.4.2.2.3 of this ETA-Guideline, Part 1.

6.2.1.3 Resistance to eccentric loads

The resistance to eccentric loads is only relevant for assemblies (See §6.1.4.3 of this part of the ETA-Guideline).

6.2.2 Safety in case of Fire

6.2.2.1 Reaction to fire

See §6.2.2.1 of this ETA-Guideline, Part 1.

6.2.2.2 Fire resistance

Fire resistance testing is only relevant for assemblies (See §6.1.2.2 of this part of the ETA-Guideline).

6.2.2.3 External fire performance (of the roof covering)

External fire performance is covered in §6.1.2.3 of this part of the ETA-Guideline.

6.2.3 Hygiene, Health and the Environment

6.2.3.1 Release of dangerous substances

See §6.1.3.1 of this part of the ETA-Guideline. Additional assessment criteria may be described in §6.2.3.1 of this ETA-Guideline, Part 1.

6.2.3.2 Water vapour permeability

See §6.2.3.2 of this ETA-Guideline, Part 1.

6.2.3.3 Moisture resistance

Moisture resistance is considered as a kit related requirement (see §6.1.3.3 of this part of the ETA-Guideline).

6.2.3.4 Fitness for contact with food and feedstuffs

See §6.2.3.4 of this ETA-Guideline, Part 1.

6.2.3.5 Air tightness

The air tightness of the composite panels is being considered under ER6 (See §6.2.6.2 of this part of the ETA-Guideline).

6.2.3.6 Watertightness

Watertightness is covered in §6.1.3.6 of this part of the ETA-Guideline.

6.2.4 Safety in Use

6.2.4.1 General

The Essential Requirement 1 is not relevant for components of building envelope kits, but all characteristics covered under ER1 (see §6.2.1 of this part of the ETA-Guideline) are relevant for these building envelope kits under ER4.

6.2.4.2 Slipperiness of floor surfaces

See §6.2.4.4 of this ETA-Guideline, Part 1.

6.2.4.3 Safety against personal injuries by contact

The safety against personal injuries by contact is being considered as an assembly requirement only (See §6.1.4.5 of this part of the ETA-Guideline).

6.2.4.4 Safety against entrapment

The safety against entrapment is being considered as a requirement, relevant for doors and gates only (See §6.3.4.6 of this part of the ETA-Guideline).

6.2.4.5 Safety against collapse

The safety against collapse is being considered as an assembly requirement only (See §6.1.4.7 of this part of the ETA-Guideline).

6.2.5 Protection against Noise

6.2.5.1 Airborne sound insulation

Airborne sound insulation is covered in §6.1.5.1 of this part of the ETA-Guideline.

6.2.5.2 Impact sound insulation

Impact sound insulation is covered in §6.1.5.2 of this part of the ETA-Guideline.

6.2.5.3 Sound absorption

Sound absorption is covered in §6.1.5.3 of this part of the ETA-Guideline.

6.2.6 Energy Economy and Heat Retention

6.2.6.1 Thermal performance

See §6.2.6.1 of this ETA-Guideline, Part 1.

6.2.6.2 Air permeability

See §6.2.6.2 of this ETA-Guideline, Part 1.

6.2.6.3 Water vapour permeability

The hygrothermal behaviour of composite panels is being assessed under ER3 (in §6.2.3.2 of this part of the ETA-Guideline).

6.2.6.4 Thermal inertia

Thermal inertia is covered in §6.1.6.4 of this part of the ETA-Guideline.

6.2.7 Aspects of Durability, Serviceability and Identification

6.2.7.1 Durability

6.2.7.1.1 Panels:

See §6.2.7.1.1 of this ETA-Guideline, Part 1.

6.2.7.1.2 Faces:

See §6.2.7.1.2 of this ETA-Guideline, Part 1.

6.2.7.1.3 Coatings:

6.2.7.1.3.1. Resistance to humidity

After the test, the blistering shall be smaller or equal than the blistering category 2(S2) as defined in ISO 4628-2.

6.2.7.1.3.2. Resistance to salt spray

The test results shall be in accordance with the conditions as specified in table 6.5.

Table 6.5: Resistance to salt spray

Category	I	II	III and IIIa	IV, IVb, V, Vc and VI
Duration of test (h)	150	240	360	500
Allowed delamination	≤ 2 mm on average on each side under the vertical incision ≤ 8 mm on average on an unprotected cut			
Blistering on the recto face	After the test, the blistering shall be smaller or equal than the blistering category 2(S2) as defined in ISO 4628-2.			

6.2.7.1.3.3. Resistance to the combined action of UV and condensation.

The colour difference (ΔE^*) of the sample, before and after the test, and the residual specular gloss after the test shall be in accordance with the requirements of table 6.6.

Table 6.6: Resistance to UV-radiation and condensation

Category	III	IV	V	VI
Colour difference (ΔE^*)	$\Delta E^* \leq 5$	$\Delta E^* \leq 3$		$\Delta E^* \leq 2$
Specular gloss Retention (RB)	RB ≥ 30 %	RB ≥ 60 %		RB ≥ 80 %
The value ΔE^* is not applicable for saturated colours. In that case, the verification method and criteria should be agreed between ETA-applicant and approval body.				

6.2.7.1.4 Floor finishes:

See §6.2.7.1.4 of this ETA-Guideline, Part 1.

6.2.7.2 Serviceability

6.2.7.2.1 Provisions related to the kit as a whole

Provisions related to the kit as a whole are given in §6.1.7.2.1 of this part of the ETA-Guideline.

6.2.7.2.2 Provisions related to composite panels

6.2.7.2.2.1 Performance characteristics of finishes

See §6.2.7.2.2.3 of this ETA-Guideline, Part 1.

6.2.7.2.2.2 Floor finishes

See §6.2.7.2.2.4 of this ETA-Guideline, Part 1.

6.2.7.2.3 Provisions related to ancillary components of the kits

Provisions related to ancillary components are given in §6.1.7.2.3 of this part of the ETA-Guideline.

6.2.7.3 Identification

See §6.2.7.3 of this ETA-Guideline, Part 1.

6.3 ASSESSING AND JUDGING OF THE FITNESS FOR USE OF COMPONENTS OF THE KIT: DOORS, GATES AND WINDOWS, ROOF WINDOWS AND ROOFLIGHTS

6.3.1 Mechanical Resistance and Stability

This essential requirement is not relevant for components of cold storage envelope kits. Aspects of mechanical resistance and stability for cold storage building kit components are being considered as part of "safety in use" (see §6.2.4 of this part of the ETA-Guideline).

6.3.2 Safety in case of Fire

6.3.2.1 Reaction to fire

Doors, gates and windows, roof windows and rooflights shall be classified in accordance with EN 13501-1.

6.3.2.2 Fire resistance

See §6.3.2.2 of this ETA-Guideline, Part 1.

6.3.2.3 External fire performance (of the roof covering)

External fire performance is covered in §6.1.2.3 of this part of the ETA-Guideline.

6.3.3 Hygiene, Health and the Environment

6.3.3.1 Release of dangerous substances

See §6.1.3.1 of this part of the ETA-Guideline. Additional provisions may be described in prEN 14351-1, -2 or -3 (for doors and windows and roof windows), EN 1873 (for individual rooflights) or prEN 14963 (for continuous rooflights) or EN 13241-1 and prEN 13241-2 (for industrial doors and gates).

6.3.3.2 Water vapour permeability

See §6.3.3.2 of this ETA-Guideline, Part 1.

6.3.3.3 Moisture resistance

Moisture resistance is considered as a kit related requirement (see §6.1.3.3 of this part of the ETA-Guideline).

6.3.3.4 Fitness for contact with food and feedstuffs

See §6.3.3.4 of this ETA-Guideline, Part 1.

6.3.3.5 Air tightness

The air tightness of doors, gates and windows, roof windows and rooflights is being considered under ER6 (in §6.3.6.2 of this part of the ETA-Guideline).

6.3.3.6 Watertightness

Watertightness is covered in §6.1.3.6 of this part of the ETA-Guideline.

6.3.4 Safety in Use

6.3.4.1 Impact resistance

See §6.3.4.1 of this ETA-Guideline, Part 1.

6.3.4.2 Mechanical resistance

6.3.4.2.1 Fixing resistance

The fixing resistance is only relevant for:

- assemblies: see §6.1.4.2.1 of this part of the ETA-Guideline
- composite panels: see §6.2.4.2.1 of this part of the ETA-Guideline
- fixing systems: see §6.4.4.2.1. of this part of the ETA-Guideline

6.3.4.2.2 Mechanical resistance of wall, ceiling and floor panels

In accordance with §5.3.4.2.2 of this ETA-Guideline, classification of complete doors, gates and windows, roof windows and rooflights shall be carried out in accordance with EN 12210, but under the following conditions: 1200 Pa \pm 1 % for internal doors and gates and 2000 Pa \pm 1 % for external doors and gates. The deflection of fixed frame elements shall be determined by calculation or test.

6.3.4.2.3 Mechanical resistance of cold storage building envelopes

The mechanical resistance of cold storage building envelopes is only relevant for assemblies (See §6.1.4.2.3 of this part of the ETA-Guideline).

6.3.4.3 Resistance to eccentric loads

The resistance to eccentric loads is only relevant for assemblies (See §6.1.4.3 of this part of the ETA-Guideline).

6.3.4.4 Slipperiness of floor surfaces

Not relevant. The slipperiness of floor surfaces is being considered as a component requirement only (See §6.2.4.4 of this part of the ETA-Guideline).

6.3.4.5 Safety against personal injuries by contact

The safety against personal injuries by contact is being considered as an assembly requirement only (See §6.1.4.5 of this part of the ETA-Guideline).

6.3.4.6 Safety against entrapment

See §6.3.4.6 of this ETA-Guideline, Part 1.

6.3.4.7 Safety against collapse

The safety against collapse is being considered as an assembly requirement only (See §6.1.4.7 of this part of the ETA-Guideline).

6.3.5 Protection against Noise

6.3.5.1 Airborne sound insulation

Airborne sound insulation is covered in §6.1.5.1 of this part of the ETA-Guideline.

6.3.5.2 Impact sound insulation

Impact sound insulation is covered in §6.1.5.2 of this part of the ETA-Guideline.

6.3.5.3 Sound absorption

Sound absorption is covered in §6.1.5.3 of this part of the ETA-Guideline.

6.3.6 Energy Economy and Heat Retention

6.3.6.1 Thermal performance

See §6.3.6.1 of this ETA-Guideline, Part 1.

6.3.6.2 Air permeability

In general, assessment of the air permeability of the components is considered unnecessary, because the air permeability of the assembled cold storage building is being assessed.

However, if testing is required, the air permeability of doors, gates, windows, roof windows and rooflights and panels with transparent surfaces, shall be classified in accordance with EN 12207.

6.3.6.3 Water vapour permeability

The hygrothermal behaviour of doors, gates and windows, roof windows and rooflights is being assessed under ER3 (in §6.3.3.2 of this part of the ETA-Guideline).

6.3.6.4 Thermal inertia

Thermal inertia is covered in §6.1.6.4 of this part of the ETA-Guideline.

6.3.7 Aspects of Durability, Serviceability and Identification

6.3.7.1 Durability

See §6.3.7.1 of this ETA-Guideline, Part 1.

6.3.7.2 Serviceability

See §6.3.7.2 of this ETA-Guideline, Part 1.

6.3.7.2.3 Provisions related to ancillary components of the kits

Provisions related to ancillary components are given in §6.1.7.2.3 of this part of the ETA-Guideline.

6.3.7.3 Identification

Identification of doors, gates and windows, roof windows and rooflights shall be performed in accordance with §6.1.7.3 and §5.3.7.3 of this part of the ETA-Guideline.

The ETA shall at least specify the following information for as specified in §6.3.7.3 of this ETA-Guideline, Part 1.

6.4 ASSESSING AND JUDGING OF THE FITNESS FOR USE OF COMPONENTS OF THE KIT: FIXING SYSTEMS, SEALANTS, GASKETS AND BUILDING HARDWARE

6.4.1 Mechanical Resistance and Stability

This essential requirement is not relevant for components of cold storage envelope kits. Aspects of mechanical resistance and stability for cold storage building kit components are being considered as part of "safety in use" (see §6.2.4 of this part of the ETA-Guideline).

6.4.2 Safety in case of Fire

6.4.2.1 Reaction to fire

Not relevant for these components, unless the cold storage building or building envelope kit is subject to reaction to fire regulations.
In that case, the following shall apply:

6.4.2.1.1 Point fixing systems

These shall be classified as a part of a door set (See §6.3.2.1 of this part of the ETA-Guideline) or as part of the panel assembly (See §6.2.2.1 of this part of the ETA-Guideline).

6.4.2.1.2 Other components

See §6.4.2.1.2 of this ETA-Guideline, Part 1.

6.4.2.2 Fire resistance

Fire resistance testing is only relevant for assemblies (See §6.1.2.2 of this part of the ETA-Guideline). These components shall be assessed as a part of the assembly.

6.4.2.3 External fire performance (of the roof covering)

External fire performance is covered in §6.1.2.3 of this part of the ETA-Guideline.

6.4.3 Hygiene, Health and the Environment

6.4.3.1 Release of dangerous substances

See §6.1.3.1 of this part of the ETA-Guideline. Additional provisions may be described in:

- Fixing systems: ETA-Guideline 001
- Sealants: ETA-Guideline xx1
- Gaskets: EN 12365-1
- Building hardware: No additional information available

6.4.3.2 Water vapour permeability

See §6.4.3.2 of this ETA-Guideline, Part 1.

6.4.3.3 Moisture resistance

Moisture resistance is considered as a kit related requirement (see §6.1.3.3 of this part of the ETA-Guideline).

6.4.3.4 Fitness for contact with food and feedstuffs

The Approval body shall check whether the kit components and/or the ETA-applicant's specifications (as applicable) take into account the provisions as specified in §5.4.3.4 of this part of the ETA-Guideline. If any of these provisions are not foreseen, then the kit shall be considered not be intended to store packaged and/or unpackaged food or feed. For components of cold storage building or building envelope kits intended to store packaged and/or unpackaged food or feed, No performance determined is not an option.

6.4.3.5 Air tightness

The air tightness is being considered under ER6 (in §6.4.6.2 of this part of the ETA-Guideline).

6.4.3.6 Watertightness

Watertightness is covered in §6.1.3.6 of this part of the ETA-Guideline.

6.4.4 Safety in Use

6.4.4.1 Impact resistance

Not relevant for these components. They shall be assessed as a part of the assembly (See §6.1.4.1 of this part of the ETA-Guideline).

6.4.4.2 Mechanical resistance

6.4.4.2.1 Fixing resistance

The fixing resistance is only relevant assemblies (See §6.1.4.2.1 of this part of the ETA-Guideline), composite panels (See §6.2.4.2.1 of this part of the ETA-Guideline) and fixing systems. It is not relevant for sealants, nor for gaskets.

If sufficient evidence is not available from tests performed in accordance with §5.1.4.2.1 and §5.2.4.2.1 of this part of the ETA-Guideline, then the results from the tests in accordance with §5.4.4.2.1 of this part of the ETA-Guideline shall be declared.

6.4.4.2.2 Mechanical resistance of wall, ceiling and floor panels

The mechanical resistance of wall, ceiling and floor panels is only relevant for composite panels (See §6.2.4.2.2 of this part of the ETA-Guideline).

6.4.4.2.3 Mechanical resistance of cold storage building envelopes

The mechanical resistance of cold storage building envelopes is only relevant for assemblies (See §6.1.4.2.3 of this part of the ETA-Guideline).

6.4.4.3 Resistance to eccentric loads

Not relevant for these components. They shall be assessed as a part of the assembly in the test to determine the resistance to eccentric loads of the assembly (See §6.1.4.3 of this part of the ETA-Guideline).

6.4.4.4 Slipperiness of floor surfaces

Not relevant. The slipperiness of floor surfaces is being considered as a component requirement only (See §6.2.4.4 of this part of the ETA-Guideline).

6.4.4.5 Safety against personal injuries by contact

The safety against personal injuries by contact is being considered as an assembly

requirement only (See §6.1.4.5 of this part of the ETA-Guideline).

6.4.4.6 Safety against entrapment

The safety against entrapment is being considered as a requirement, relevant for doors and gates only (See §6.3.4.6 of this part of the ETA-Guideline).

6.4.4.7 Safety against collapse

The safety against collapse is being considered as an assembly requirement only (See §6.1.4.7 of this part of the ETA-Guideline).

6.4.5 Protection against Noise

6.4.5.1 Airborne sound insulation

Airborne sound insulation is covered in §6.1.5.1 of this part of the ETA-Guideline.

6.4.5.2 Impact sound insulation

Impact sound insulation is covered in §6.1.5.2 of this part of the ETA-Guideline.

6.4.5.3 Sound absorption

Sound absorption is covered in §6.1.5.3 of this part of the ETA-Guideline.

6.4.6 Energy Economy and Heat Retention

6.4.6.1 Thermal performance

See §6.4.6.1 of this ETA-Guideline, Part 1.

6.4.6.2 Air permeability

Not relevant for these components. They shall be assessed as a part of the assembly (See §6.1.6.2 of this part of the ETA-Guideline).

6.4.6.3 Water vapour permeability

The hygrothermal behaviour is being assessed under ER3 (in §6.4.3.2 of this part of the ETA-Guideline).

6.4.6.4 Thermal inertia

Thermal inertia is covered in §6.1.6.4 of this part of the ETA-Guideline.

6.4.7 Aspects of Durability, Serviceability and Identification

6.4.7.1 Durability

See §6.4.7.1 of this ETA-Guideline, Part 1
Additionally, the exposure to external conditions needs to be taken into account.

6.4.7.2 Serviceability

6.4.7.2.1 Provisions related to the kit as a whole

Provisions related to the kit as a whole are given in §6.1.7.1 of this part of the ETA-

Guideline.

6.4.7.2.2 Provisions related to fixing systems, sealants, gaskets and building hardware

6.4.7.2.2.1 Fixing systems

No additional requirements.

6.4.7.2.2.2 Sealants

See §6.4.7.2.2.2 of this ETA-Guideline, Part 1

6.4.7.2.2.3 Gaskets

6.4.7.2.2.3.1 Resistance to changes in temperatures

The product is judged by evaluating the re-deformation which shall be at least 50% larger than the nominal joint width.

If claimed, the product shall remain watertight after being subjected to the driving rain test.

6.4.7.2.2.3.2 Resistance to UV radiation

The product is judged by evaluating the re-deformation which shall be at least 25% larger than the nominal joint width.

If claimed, the product shall remain watertight after being subjected to the driving rain test.

6.4.7.2.2.3.3 In service temperature range

See §6.4.7.2.2.3.2 of this ETA-Guideline, Part 1

6.4.7.2.2.4 Building hardware

No additional requirements.

6.4.7.2.3 Provisions related to ancillary components of the kits

Provisions related to ancillary components are given in §6.1.7.2.3 of this part of the ETA-Guideline.

6.4.7.3 Identification

Identification of fixing systems, sealants, gaskets and building hardware shall be performed in accordance with §6.1.7.3 and §5.4.7.3 of this part of the ETA-Guideline.

6.5 ASSESSING AND JUDGING OF THE FITNESS FOR USE OF COMPONENTS OF THE KIT: PROFILES, FRAMEWORK, STUDS, ETC.

6.5.1 ER1: Mechanical resistance and stability

6.5.1.1 General

The performance of the supporting framework will have been determined by calculations, testing or a combination of calculation and testing.

6.5.1.2 Calculation

Where the performance of the supporting framework has been determined by calculation in accordance with the relevant Eurocodes (see 5.5.1.1) the bearing, bending and shear capacities together with predictions for deformations shall be determined. Any Nationally Determined Parameters (NDP) used shall be declared.

6.5.1.3 Testing

Where the performance of the supporting framework has been determined by testing or a combination of calculation and testing, then the principles of the relevant structural Eurocodes shall be followed to determine an overall performance relating to strength and stiffness.

The statistical analysis of the test results to determine the characteristic value is to be undertaken according to EN 1990.

6.5.2 ER2: Safety in case of fire

6.5.2.1 Reaction to fire

The component shall be classified according to EN 13501-1.

6.5.3 ER3: Hygiene, health and the environment

6.5.3.1 Release of dangerous substances

See §6.1.3.1.

6.5.4 ER4: Safety in use - Mechanical resistance and stability (for room and building envelope kits only)

See §6.5.1

6.5.5 Protection against noise

Not relevant to this component

6.5.6 Energy economy and heat retention

Considered in relation to the kit

6.5.7 Aspects of durability, serviceability and identification

6.5.7.1 Durability and serviceability requirements

The technical file and the ETA shall contain details of the supporting framework materials and the means by which their durability has been proven. Where the evidence is from previous assessments or from experience it shall be clear over what period the evidence has been gathered and under what circumstances the material and/or its corrosion protection or preservative treatment has proved satisfactory. Comment shall be made on any hazard that might arise in particular exposure conditions e.g. marine or industrial areas.

7. ASSUMPTIONS AND RECOMMENDATIONS UNDER WHICH THE FITNESS FOR USE OF THE PRODUCTS IS ASSESSED

This chapter sets out the assumptions, recommendations for design, installation and execution, packaging, transport and storage, use, maintenance and repair under which the assessment of the fitness for use according to the ETA-Guideline can be made (only when necessary and in so far as they have a bearing on the assessment or on the products).

7.1 DESIGN OF WORKS

7.1.1 General

The design of a building, incorporating a cold storage building envelope or building kit, will most of the time, not be specific to the works on which it is to be used.

However, there are a few aspects it is assumed will be taken into account when designing the building in which the cold storage building envelope kit(-s) or building kit(-s) is/are to be incorporated; the list is not exhaustive:

- Attachment of the supports to the structure of the building
- The assessment of condensation risk and the provision of vapour control layers and thermal insulation
- Fire protection and compartmentation
- Means of access for inspection and maintenance
- Mechanical resistance and stability of the floor construction

The ETA shall indicate the conditions for design of the particular cold storage building envelope and building kit into the works. It is for the designer to ensure that the cold storage building envelope and building kit as installed in the works provides the required performance on the basis of the information given in the ETA such as the following:

- Where and how the kit is fixed to the rigid supports
- When appropriate, special fixings for seismic conditions. In case of dynamic actions such as those occurring in case of an earthquake, the designer shall take account of the possible contribution of the cold storage building envelope and building kit in accordance with national or local regulations.

7.1.2 Specific

7.1.2.1 In-service safety provisions

7.1.2.1.1 Doors and gates

Apart from the measures foreseen in the previous chapters (safety release provisions on doors and gates), an additional pedestrian door should be foreseen, if the cold storage building is sufficiently large. Such additional door should be located as a means for quick evacuation in the case of an emergency. Escape doors should open outwards and be fitted with an easily operated opening mechanism, activated from the inside only.

A provision should foresee that it is possible to open the main door and gate from the inside, even when it has been locked externally.

7.1.2.1.2 Pressure equalising devices

For cold storage buildings intended to be used in negative temperatures, even when no such provisions are part of the cold storage building envelope and building kit, pressure equalising device(-s) should be fitted in each cold storage building, to prevent damaged caused by under or over pressure, resulting from for instance defrosting or the

introduction of warm products in large quantities.

7.1.2.1.3 Other safety provisions

Other safety provisions, such as the presence of alarm systems, telephones and transparent surfaces in doors or gates might improve in-service safety considerably. It is possible that in some countries such provisions are regulated, depending on the intended use and/or size of the assembled cold storage building envelope and building.

The assembled kit should ensure a satisfactory air quality and in general a healthy indoor environment for cold storage building users. Where relevant, the ventilation rate should at least correspond with minimum regulatory requirements.

Active fire protection provisions (e.g. fixed fire fighting systems) should be incorporated, at least in accordance with national regulatory requirement.

7.1.2.2 Cold storage building envelope or building floor

7.1.2.2.1 Protection of the building floor (and foundation)

The designer should take into account that the presence of the cold storage building, inducing low temperatures in the ground, might lead to water in the ground becoming frozen. In certain subsoils, this might lead to "frost heave".

Cold storage buildings might suffer damages, if the freezing plane in the ground is permitted to move into the soil that is susceptible to frost (usually soils with fine grains, through which moisture can move), where moisture is present, due to subsequent build-up of ice.

The necessary provisions should be taken (e.g. sufficient insulation, heating devices, alarm systems). The design method, given in EN ISO 13793 should be taken into account, but special attention should be paid to the low temperatures that the cold storage building induces.

7.1.2.2.2 Energy conservation

If the kit for prefabricated cold storage building envelope and building does not contain floor panels all necessary precautions should be taken to prevent disproportionate loss of energy due to insufficient building floor insulation.

7.1.2.2.3 Frost damage

If on site applied concrete or mortar is being used as a part of the floor construction, the floor should be allowed to dry out sufficiently, to limit the amount of humidity in it, preventing frost damage.

7.1.2.2.4 Discontinuously laid floor finishes

If discontinuously laid floor finishes are used (tiles, sheets), it is generally recommended to:

- use resin based joint materials, because they are more resistant to chemical, physical and biological deterioration, to high-pressure cleaning and to thermal loads and humidity, which is essential to prevent frost damage.
- limit the difference in height between the elements and to give flatness requirements, especially in relationship with important dynamic and static loads (e.g. vehicular traffic).

7.1.2.2.5 Floor slipperiness

It should not be expected that floor coverings, complying with the criteria set in §6.1.4.4, provide an automatic guarantee that no person (or vehicle) ever slips and falls on it.

7.1.2.3 Food safety

7.1.2.3.1 Council Directive 93/43/EEC of 14 June 1993 on the hygiene of foodstuffs

Council Directive 93/43/EEC lays down the general rules of hygiene for foodstuffs. It supplements Council Directive 89/397/EEC of 14 June 1989 on the official control of foodstuffs. These general rules, as set out in the annex of the Directive, should be observed at the time of preparation, processing, manufacturing, packaging, storing, transportation, distribution, handling and offering for sale and supply of foodstuffs. The Directive is a horizontal Directive and therefore applies across the whole of the food industry. It covers producers, manufacturers, distributors, wholesalers, retailers and caterers. Food businesses are required to use a self-control programme (Hazard analysis and critical control points (HACCP) system) and foresee maintenance to ensure safety of foodstuffs.

7.1.2.3.2 Food safe internal panel facings

To comply with the EC Foodstuff directive (93/43/EEC), wall and ceiling surfaces should be smooth, light coloured, durable, impermeable, easily cleaned and, where necessary, disinfected.

In areas prone to high humidity and condensation, the surface materials and finishes should be selected to minimise flaking and mould growth.

Designers should evaluate where the emphasis related to safety lies when determining floor finishes. Generally, "food safe" floor finishes are easily cleanable, which makes them less slip resistive (and vice versa). If slippery floors are not avoidable, users should be made aware of the nature of the risk and/or special footwear should be provided.

Note: Wall and ceiling finishes should be light coloured, so that contamination is clearly visible.

7.1.2.3.3 Food safe shelving

Shelving and shelf supporting systems of cold storage building envelope and building kits intended to be used to store unpackaged food or feed, should be easily cleanable and should not provide harbourage for vermin. It should, in most cases, be readily removable.

7.1.2.3.4 Food safe equipment

Equipment of cold storage buildings intended to be used to store unpackaged food or feed, should be accessible for the necessary cleaning and maintenance.

Evaporator coils, refrigerant tubing and alike should not be in direct contact with food contact surfaces and should be installed so that condensate, if any, does not contact food or insulation.

7.1.2.3.5 Food safe equipment mounting

Floor mounted equipment of cold storage buildings intended to be used to store unpackaged food or feed, should be:

- Portable; or
- Mobile; or
- Designed to be sealed to the floor; or
- Elevated on legs that provide a sufficient clearance beneath the equipment to facilitate cleaning.

Equipment intended to be sealed to the floor should not create inaccessible cavities or areas that may be subject to soiling or vermin harbourage.

7.1.2.3.6 Food safe temperature controls

Cold storage buildings intended to be used to store packaged and/or unpackaged food or feed, shall have automatic controls capable of maintaining temperatures in accordance

with the relevant performance requirements.

7.1.2.3.7 Food safe temperature indicating devices

Each cold storage building compartment intended to be used to store packaged and/or unpackaged food or feed, should at least have one securely mounted temperature indicating device that clearly displays the air temperature in the compartment, which should be visible immediately upon opening a door or gate to the cold storage compartment or from outside.

The sensing element of the device should be easily cleanable.

The temperature indicating devices should be removable.

7.1.2.3.8 Food safe kits without floor panels

If a cold storage building envelope or building kit includes prefabricated floor panels, the corner formed at the floor-wall intersection shall conform to the minimum radius requirement in §5.1.3.4.1.2.

This requirement also applies if an in-situ applied floor (e.g. concrete, tiles, ...) is to be installed on top of the prefabricated panels or if floor panels are not part of the kit. In that case, the required radius should be executed using appropriate site applied materials (concrete, mortar, ...).

Kits without floor panels shall be manufactured so that the joints formed between the wall panels and the floor may be closed and sealed upon assembly.

Floor drainage should be foreseen in floors that are being cleaned by flushing water. If this is the case, floors should slope towards the drainage.

7.1.2.4 Equipment and in-service loads

The cold storage building should be designed to ensure that imposed equipment (compressors, condensers, evaporators, refrigerant pumps, incl. pipes and conduits, etc.) and in-service loads (e.g. ice build-up) do not adversely affect the stability of the structure and the integrity of the joints.

When cold storage buildings are intended to be used at low temperatures (below -20°C), attention is drawn to the desirability of employing steel with suitable low temperature ductility, especially for load-bearing parts of the structure, which may be subjected to dynamic loads.

Structural perimeter kerbs or other similar provisions should be foreseen at the base of the cold storage building walls and/or partitions, if it is likely that vehicles (or alike) might accidentally impact with the cold storage building elements.

7.1.2.5 Water vapour barrier

The continuity and integrity of the vapour barrier is essential. This aspect becomes critical when the floor panels are not part of the kit.

When determining the internal cold storage building finishes, the designer has to take into account that "food safe" finishes are impervious. This property has to be taken into consideration, when determining the hygrothermal build-up of the construction.

Designers should be aware that the vapour barrier should usually be situated at the "warmest" side of the construction. In most West-European situations, this is usually the outside of the cold storage building construction, but not necessarily so (i.e. if the exterior temperature is colder than the temperature inside the cold storage building).

7.1.2.6 Provisions limiting energy consumption

Equipment is usually being made available by the ETA-holder to limit air infiltration. Such

provisions, e.g. strip curtains or rapid roll fabric doors, may have a substantial influence on energy conservation.

7.2 PACKAGING, TRANSPORT AND STORAGE

The cold storage building envelope and building kit shall be protected from mechanical damage, bowing, discolouration and excessive exposure to direct sunlight and moisture during transportation and storage. Damaged components shall not be used.

The kits shall be handled and stored with care and be protected from accidental damage.

During transportation and site storage, panels and other kit components, shall be protected against humidity, heat and direct sunlight. In cases where a protective film has been temporarily adhered to composite panel' faces, the expiry date of the film should be clearly indicated.

7.3 EXECUTION OF WORKS

7.3.1 General

Essential conditions for design and execution of the kit into the works shall be taken from the ETA-holder's installation guide.

The quality and sufficiency of this installation guide shall be assessed, in particular concerning the following check list, which is not exhaustive:

- provisions for installing openings in panels (e.g. for technical equipment)
- type of fixing systems
- tolerances
- provision for thermal expansion or shrinkage
- order of installation of the various components

The installation guide is **not** a part of the ETA. The ETA-holder is responsible for delivering the installation guide to the purchaser.

7.3.2 Erection of cold storage building envelopes and buildings

The ETA-holder's installation guide should pay special attention to the following risks:

- If on site cutting of panels is foreseen as part of the ETA-holder's specifications, the installation guide shall provide at least the following guidance:
 - Appropriate method to cut panels on site.
 - Removal of waste material, which should be completely removed from the cut edges of the panels.
 - Appropriate measures, and products, to ensure corrosion resistance of the panels.
 - Provisions to ensure that the panels, and the cold storage building enclosure, meet the requirements to ensure that the assembled kit meets the essential requirements, and especially that they are water vapour tight.
- See also §7.4.4 regarding the walkability of ceilings

7.3.3 Putting into service

Prior to lowering the temperature, a thorough check should be carried out to ensure that the cold storage building envelope and building has been constructed in accordance with ETA-holder's specification and that especially the stability and the vapour tightness requirements have been met.

When the cold storage building is being put into service, the necessary precautions

should be taken when decreasing the temperature first down to 0 °C and secondly to the intended storage temperature.

These precautions should be in accordance with ETA-holder's specification (see 2nd note), but need to address the following:

- the temperature should be decreased during a sufficiently long period
- in most cases, the door or gate is left partly open when decreasing the temperature below 0 °C up to the intended storage temperature.
- in accordance with the ETA-holder's specifications, the door or gate should be shut, when the temperature is near to the intended storage temperature.

Notes:

- Pressure relief devices are usually not designed to compensate pressures at the time of putting into service. This function can only be compensated by the partial opening of the door or gate. Neglecting this measurement can cause collapse of the ceiling.
- Indicatively, the following recommendations are given for large cold storage buildings: the speed of descent of the temperature of the building envelope and building must be controlled. When reducing the temperature from ambient temperature to 0 °C, the speed of descent should not exceed 15 K per 24 h. When the envisaged operating temperature is lower or equal to 0 °C, an additional stage should be foreseen, when the temperature approaches 0 °C. The duration of this stage depends on the water content of materials and is usually between two and eight days. From 0 °C on, the speed of temperature reduction, should not exceed 5 K per 24 h.
- The speed with which the temperature is allowed to decrease, and the moment upon which the door or gate should be closed, depends on the volume of the cold storage building envelope and building.

7.4 MAINTENANCE, REPAIR AND CLEANING

The assessment of the fitness for use is based on the assumption that normal maintenance of the cold storage building envelopes and buildings is performed.

This maintenance shall at least include:

- cleaning, as necessary, carried out with appropriate cleaning products. It is a normal assumption that the cold storage building envelopes and buildings shall not be cleaned with cleaning products containing solvents or abrasive or grinding agents.
- early repair or replacement of damaged parts
- joints and vapour seal inspection to detect snow condensation and growth of micro-organisms
- replacement of components with a limited working life (e.g. jointing materials)

7.4.1 Replacing components

The ETA shall indicate whether and how replacing of components is possible.

When replacing components, the materials shall be approved by the ETA-holder and covered by the ETA for the cold storage building envelope and building kit.

7.4.2 Extending cold storage building envelopes and buildings

The ETA shall indicate whether and how extending existing cold storage building envelopes and buildings is possible.

When adding components, the materials shall be approved by the ETA-holder and covered by the ETA for the cold storage building envelope and building kit.

7.4.3 Precautions before maintaining, repairing and cleaning

Before maintaining, repairing and/or cleaning in-service cold storage buildings, the temperature of the building should be above 0 °C, and preferably at ambient temperature. Foodstuff should be evacuated from the building before raising the temperature.

7.4.4 Roofs/ceiling access

In case of inaccessible roofs/ceilings (kits with ceilings not intended to be accessed, see §2.2.3) it is necessary to provide an external structure with appropriate walkways, completely independent from the roof/ceiling, to allow a safe installation of the panels. Even when the impact resistance and walkability requirements in this ETA-Guideline have been met, most composite roof/ceiling panels deteriorate when subjected to repeated foot traffic.

When regular traffic is to be expected, it is advisable to provide walkways, either secured to the external face of the roof/ceiling panel or even completely independent from the roof/ceiling.

7.4.5 Precautions relating to replacement/retrofit

Where major or minor items have to be replaced all food or feed stuff should be either removed or effectively screened off from the operating area. The removed item(s) should be shrink-wrapped or effectively encapsulated immediately before and during transport and the newly exposed regions immediately treated with a biocide. These precautions are particularly important for dairy products where listeria bacteria can be released.

7.4.6 Precautions after maintaining, repairing and cleaning

After maintaining, repairing and/or cleaning in-service cold storage buildings, the temperature should be brought back to the intended in-service temperature, taking into account the provisions as given in §7.3.3.

Depending on the nature of the maintenance, reparation and cleaning and the materials and/or cleaning agents used, it might be necessary to ventilate the building before putting it into service again.

7.5 RECOMMENDATIONS RELATED TO THE INTERNAL AND EXTERNAL ENVIRONMENT OF COLD STORAGE BUILDINGS¹¹

7.5.1. Aggressiveness of internal cold storage building environments

The aggressiveness of internal cold storage building environments depends on the presence of

- acid, basic or saline gasses or vapours,
- exposure to disinfectant cleaning and/or
- the presence of micro-organisms.

The following categories have been defined:

Table 7.1: Definition of use categories for aggressiveness

Type	Description
Not aggressive	Absence of corrosive chemicals and/or micro-organisms
Reasonably aggressive	Not aggressive environment, but walls and floors might come into contact with lightly aggressive liquids.
Aggressive	Environments where acid fluids, gases or vapours, alkali(-s), salts and/or micro-organisms and/or disinfectants are present.
Very aggressive	Environments where walls and floors might regularly come into contact with acid fluids, gases or vapours, alkali(-s), salts and/or micro-organisms and/or aggressive disinfectants.

¹¹ These use categories have been derived from the French standard XP P 34-301:2002, adapted for use in this ETA-Guideline. The standard XP P34-301:2002 is largely based on ENV 10169-2 and EN 10169-3.

7.5.2. Aggressiveness of external cold storage building environments

The following categories have been defined:

Table 7.2: Definition of use categories for aggressiveness

External environment	Description
EE1	Rural environment, where pollution is not present
EE2	Normal urban or normal industrial environment, without an important chemical pollution of the atmosphere and no pollution of a particular corrosive nature is present
EE3	Severe urban or industrial environment, with an important chemical pollution of the atmosphere or pollution of a particularly corrosive nature is to be expected. In such cases, particular precautions should be foreseen
EE4a	Marine environment, situated in between 10 km and 20 km from the sea ($10 \text{ km} < d \leq 20 \text{ km}$)
EE4b	Marine environment, situated in between 3 km and 10 km from the sea ($3 \text{ km} < d \leq 10 \text{ km}$)
EE4c	Marine environment, situated less than 3 km from the sea ($d < 3 \text{ km}$), but the environment for buildings situated next to the sea is considered to be exceptional
EE5	Environments where constructions are exposed to high UV radiation (e.g. buildings situated higher than 900m above sea level, ...)
EE6	Environments where exceptionally high requirements need to be set, due to the aggressiveness (e.g. due to high temperatures, high humidity levels, buildings at the sea front, ...). In such cases, particular precautions should be foreseen.

Note: *d* is the distance from the sea.

7.5.2. Internal humidity exposure types for cold storage buildings:

7.5.2.1 Definition of building hygrometry conditions

Table 7.3: Definition of building hygrometry conditions

Hygrometry exposure	<i>W/n</i> - Ratio of the quantity of water vapour produced (g/h) and the ventilation ratio (m ³ /h)
Low hygrometry exposure	$\leq 2,5$
medium hygrometry exposure	$2,5 < x \leq 5$
high hygrometry exposure	$5 < x \leq 7,5$
very high hygrometry exposure	$> 7,5$

Note: The term "hygrometry" is defined as the ratio of the quantity of water vapour produced (g/h) and the ventilation ratio (m³/h)

7.5.2.2 Building humidity

The building humidity (W_i) depends on the building hygrometry conditions (W/n - see above), exterior conditions (W_e), building temperature and the ventilation: $W_i = W_e + W/n$

Buildings are classified as follows:

- Low hygrometry
- Medium hygrometry
- High hygrometry
- Humid environment, while hygrometry is very high, with intermittent condensation on walls
- Very humid environment, while hygrometry is very high, with frequent condensation on walls
- Saturated environment, while hygrometry is very high, with permanent condensation on walls

7.5.3. Cleaning methods and agents

The use categories for cleaning methods and agents, differentiates:

- aggressiveness of the cleaning agent (pH-value)

- temperature of the cleaning agent (°C)
- pressure for pressure cleaning (MPa)

Table 7.4: Definition of cleaning methods

Cleaning category	pH value	Temperature	Pressure ¹²
Ordinary cleaning	Regular cleaning, not using aggressive cleaning agents, nor high pressure cleaning		
Not intensive cleaning	Neutral	< 30°C	< 0,3 MPa
Intensive cleaning	4 < pH < 9	< 40°C	< 3,5 MPa
Very intensive cleaning	pH ≤ 4 or pH ≥ 9	< 50°C	< 5 MPa

7.5.4. Summary table - Internal environment categories

In the table below, the worst criterion (aggressiveness, cleaning agents or humidity) that might lead to deterioration, indicates the internal environment.

Example: If the environment aggressiveness is "reasonably aggressive", the cleaning agent is "ordinary" and the humidity is "medium hygrometry", then the internal environment should be classified as "IE4" and products should be used in accordance with the requirements for that Internal Environment type.

Table 7.5: Determination of Internal Environment

Internal Environment	Environment aggressiveness	Cleaning	Humidity
IE1	Not aggressive	Ordinary	Low hygrometry
IE2	Not aggressive	Ordinary	Medium Hygrometry
IE3	Not aggressive	Not intensive	High hygrometry
IE4	Reasonably aggressive	Not intensive	Humid
IE5	Aggressive	Intensive	Very humid
IE6	Very aggressive	Very intensive	Saturated

7.5.5. Classification of paints and coatings for internal and external environment categories

7.5.5.1 Internal environment categories

Having performed the assessment on the basis of the verification methods as specified in §5.2.7.1.3 and §5.2.7.2.2.2, and the corresponding classification in accordance with §6.2.7.1.3 and §6.2.7.2.2.2, the coatings can be classified in accordance with table 7.6.

¹² Pressure at the nozzle.

Table 7.6: Classification of coatings and paints

Internal Environment	Minimum required protection type	Example of representative storage circumstances
IE1	I	Storage of packaged dry goods Storage of frozen goods, with the exception of unpackaged fish
IE2	II	Cold storage Storage of dairy products and packaged meat
IE3	IIIa	Storage in humid conditions (e.g. salad, flowers, fruit) Cold storage of meat
IE4	IVb	Storage rooms for chicory, wine Storage of butter
IE5	Vc	Storage of mushrooms (cultures) Ageing of cheese Fermentation rooms Smoking and drying room Storage, freezing of unpackaged fish
IE6	-	

7.5.5.2 External environment categories

Having performed the assessment on the basis of the verification methods as specified in §5.2.7.1.3 and §5.2.7.2.2.3, and the corresponding classification in accordance with §6.2.7.1.3 and §6.2.7.2.2.3, the coatings shall be classified in accordance with table 7.6.

Table 7.6: Classification of coatings and paints

External Environment	Minimum required protection type
EE1	III
EE2	III
EE3	*
EE4a	III
EE4b	IV
EE4c	V
EE5	VI
EE6	*

* For uses in these external environments the ETA-holder should be contacted to determine appropriate panel face coatings or paints.

Section Three: ATTESTATION OF CONFORMITY

8. ATTESTATION OF CONFORMITY

8.1 EC DECISION

The systems of attestation of conformity, specified by the Commission decision .../.../EC (Construct 04/660), is system 1¹³ as described in Council Directive (89/106/EEC) Annex III, and is detailed as follows:

System 1 for any intended uses.

Tasks for the ETA-holder:

- factory production control
- further testing of samples taken at the factory by the ETA-holder in accordance with a test plan.

Tasks for the approved body:

- initial type testing of the product
- initial inspection of the factory and of factory production control
- continuous surveillance, assessment and approval of factory production control.

8.2 RESPONSIBILITIES

8.2.1 Tasks for the ETA-holder

8.2.1.1 Factory production control (FPC)

8.2.1.1.1 General

The ETA-holder shall exercise permanent internal control of the production. All the elements, requirements and provisions adopted by the ETA-holder shall be documented in a systematic manner in the form of written policies and procedures. This factory production control system shall ensure that cold storage building envelope and building kits are in conformity with the European Technical Approval (ETA).

The personnel involved in the production process shall be identified, sufficiently qualified and trained to operate and maintain the production equipment. Machinery equipment shall be regularly maintained and this shall be documented. All processes and procedures of production shall be recorded at regular intervals.

The ETA-holder shall maintain a traceable documentation of the production process from purchasing or delivery of raw or basic raw materials up to the storage and delivery of finished products.

The factory production control system for the cold storage building envelope and building kits shall normally include relevant design specifications, including adequate drawings and written instructions and at least the following items:

- type and quality of all materials and components incorporated in the cold storage

¹³ System 1: see Directive 89/106/EEC Annex III.2.(i), without audit-testing of samples.

- building envelope and building kits
- positions of components in the cold storage building envelope and building kits
- overall dimensions of cold storage building envelope and building kits
- installation of components and ancillary components
- markings for correct position and installation in the works, and special handling devices, when relevant
- packaging and transport protection
- checks that the relevant design specifications for the production do exist, e.g. structural designs, construction details and manuals for installation as mentioned in chapter 7.

The production control system shall specify how the control measures are carried out, and at which frequencies.

ETA-holders which have an FPC system that complies with EN ISO 9001 and that addresses the requirements of the ETA are recognised as satisfying the FPC requirements of the Directive.

Products that do not comply with requirements as specified in the ETA shall be separated from the conforming products and marked as such. The ETA-holder shall register non-compliant production and action(-s) taken to prevent further non-conformities. External complaints shall also be documented, as well as actions taken.

8.2.1.1.2 Incoming material/products

8.2.1.1.2.1 General

Cold storage building envelope and building kits may consist of one or more of the following possibilities:

- components produced by the ETA-holder
- components produced by an independent manufacturer (supplier)
- components purchased by the ETA-holder on the open market

In any case, sufficient proof shall be established to show that permanent internal control takes place.

When materials/products are delivered for incorporation into the production process, verification of conformity with specifications in the ETA shall take place, with special attention for the following aspects:

- the structural components are in conformity with the ETA-holder's specification and the ETA's specification.
- the coils are in conformity with relevant European product standards (e.g. EN 485-1, -2, -3 and -4, EN 573-3, EN 1172, EN 1396, EN 10326, EN 10327, EN 10088-1)
- the wood-based panels are in conformity with EN 13986
- other face materials, such as GRP-panels and PVC-panels are in conformity with ETA-holder's specifications
- it is essential that the manufacturing process ensures that the surfaces of all interfaces are not contaminated, which might adversely affect bonding.
- the insulation material is in conformity with the relevant European product standard (EN 13162, EN 13163, EN 13164, EN 13165, (EN 13166 and/or EN 13167)).
- the adhesives, where relevant, are in conformity with ETA-holder's specification and the ETA's specification. The ETA-holder shall check the expiry date (shelf life) and the density (see EN 542) or viscosity (see EN 12092) at every supply.
- provisions preventing falling due to changes in level or drops, e.g. stairs, guard rails, balustrades, barriers (e.g. ETAG 008, ISO/DIS 12055)
- rainwater disposal products (e.g. EN 607, EN 612, EN 1462)
- roof access provisions (e.g. EN 516, EN 517, EN 12951)
- roof covering products (e.g. EN 490, EN 492, EN 494, EN 501, EN 502, EN 504, EN

- 505, EN 506, EN 507, EN 508-1, -2 and -3, EN 534, EN 544, EN 1304, EN 12467, EN 12326-1)
- roof waterproofing products (e.g. EN 13707, EN 13956)
- rigid or flexible wall or roof underlays (e.g. EN 13859-1 and -2, prEN 14964)
- water vapour barriers and damp proof courses (e.g. EN 13967, EN 13969, EN 13970, EN 13984, prEN 14967, prEN 14909)

8.2.1.1.2.2 Documentation

In any case, documented verification of incoming material/products is considered good practice. A corresponding test plan should be agreed between notified body and ETA-holder.

Where materials/components are not manufactured and tested by the supplier in accordance with agreed methods, or where the ETA-holder purchases materials/components on the open market, then where appropriate, they shall be subject to suitable documented checks/tests by the ETA-holder before acceptance.

The characteristics of incoming material and components, for which the supplier demonstrates documented compliance with a product specification, for an intended use that is appropriate for its use as a part of a cold storage room kit, shall be considered satisfactory and need, except in justified doubt, no further checking, unless the test plan (see §8.3) specifies differently.

For cold storage building and building envelope kits, the following components are regarded important for the kit to meet the essential requirements, and should therefore also be attested with the corresponding A/C procedures that apply for the whole kit:

- structural components (building kits only)
- composite panels
- doors, gates and windows, roof windows and rooflights (if any)

For CE Marked components, the declaration of conformity and CE Certificates of conformity (where applicable) shall be verified by the ETA-holder at each delivery. Likewise, relevant other conformity certificates or declarations (e.g. manufacturer's declaration of conformity, inspection certificates in accordance with EN 10204, or Qualicoat approved certificates), shall be checked regularly.

It is irrelevant where incoming materials and components are produced, as long as the requirements in this chapter are met. It is also irrelevant whether or not a 3rd party was involved in attesting conformity with the technical product specification, as long as the documented evidence and their origin is acceptable for the notified body involved in attesting conformity of the ETA-holder's kit with the issued ETA, unless this chapter specifies requirements that are over and above those foreseen in the technical specifications referred to.

8.2.1.2 Testing of samples taken at the factory

8.2.1.2.1 General

Both large and small companies produce these products and there is a wide variation in the materials used. Therefore a precise test plan (see §8.3) can only be set up on a case-by-case basis.

In general, it is not necessary to conduct tests on complete cold storage building envelope and building kits. Tests on kit components, in some cases by indirect methods, are normally sufficient.

The following minimum information shall be recorded:

- date and time of manufacture
- type of product produced

- material specification
- all results of the verifications performed within the agreed upon test plan

8.2.1.2.2 Maintenance, checking and calibration of equipment

All testing equipment shall be maintained, calibrated and/or checked against equipment or test specimens traceable to relevant international or nationally recognised reference test specimens (standards). In case no such reference test specimens exist, the basis used for internal checks and calibration shall be documented.

The ETA-holder shall ensure that handling, preservation and storage of test equipment is such that its accuracy and fitness for purpose is maintained

When production is intermittent, the ETA-holder shall ensure that any test equipment which may be affected by the interruption is suitably checked and/or calibrated before use. The calibration of all test equipment shall be repeated if any repair or failure occurs which could upset the calibration of the test equipment.

8.2.1.3 Declaration of conformity

When all the criteria of the conformity attestation are satisfied the ETA-holder shall make a declaration of conformity. The declaration of conformity shall also contain the CE Marking (see §8.4). Duplication of information between CE Marking and declaration should be prevented.

With each cold storage building or building envelope kit put on the market in the EEA, the ETA-holder shall provide to the purchaser a declaration of conformity. A copy shall be retained by the ETA-holder. Each declaration has a unique number.

Notes:

- Most cold storage premises kit ETAs will cover kits that offer a range of solutions (e.g. different types of doors, windows, different thicknesses of insulation, with or without any number of ancillary components, ...) and therefore both the EC Declaration of conformity and CE Marking would be very extensive and very detailed documents in many cases. Therefore, it has been agreed that the EC Declaration of conformity and CE Marking will be combined in one document (preventing duplication), as each kit put on the market is potentially, not necessarily, different, and so would the CE Marking and EC Declaration of conformity. In accordance with the CPD, the CE Marking must accompany the product and therefore the purchaser receives a copy of the EC Declaration/CE Marking when the kit is placed on the market and the original is to be retained by the party signing the EC Declaration of conformity, allowing the NB to verify whether CE Marking is performed as required. Each declaration is uniquely numbered to allow traceability
- An example declaration of conformity is presented in Annex N of Part 1 of this ETA-Guideline

8.2.2 Tasks for the ETA-holder or the approved body

Initial Type Testing

The approval tests will have been conducted by the approval body or under its responsibility (which may include a proportion conducted by an independent laboratory or by the ETA-applicant, witnessed by the approval body) in accordance with chapter 5 of this ETA-Guideline. The approval body will have assessed the results of these tests in accordance with chapter 6 of this ETA-Guideline, as part of the ETA issuing procedure.

These tests shall be used for the purposes of Initial Type Testing and this work shall be validated by the approved body for Certificate of Conformity purposes.

8.2.3 Tasks for the approved body

8.2.3.1 Assessment of the factory production control system - initial inspection and continuous surveillance

Assessment of the factory production control system is the responsibility of the approved body.

An assessment shall be carried out of each production unit or line (if one unit consists of more than one line) to demonstrate that the factory production control is in conformity with the ETA and any subsidiary information. This assessment shall be based on an initial inspection of the factory. The relevant production units or lines shall be specified in the ETA.

Subsequently continuous surveillance of factory production control is necessary to ensure continuing conformity with the ETA. It is recommended that Surveillance inspections are to be conducted at least twice a year.

During surveillance of factory production control, the issued EC Declarations of conformity shall be checked.

Note: Annex J of Part 1 of this ETA-Guideline contains a recommended checklist for initial inspection and continuous surveillance of the FPC system.

8.2.3.2 Certification

The approved body shall issue certification of conformity of the cold storage building envelope and building kits. One certificate shall be issued for each ETA, demonstrating conformity of production with the ETA.

Note: An example CE Certificate is presented in Annex M of Part 1 of this ETA-Guideline.

8.3 DOCUMENTATION

In order to help the approved body make an evaluation of conformity the approval body issuing the ETA shall supply the information detailed below. This information, together with the requirements given in EC Guidance Paper B will generally form the basis on which the factory production control (FPC) is assessed by the approved body.

This information shall initially be prepared or collected by the approval body and shall be agreed with the ETA-holder. The following gives guidance on the type of information required:

(1) The ETA

See section 4 of this Guideline. The nature of any additional (confidential) information shall be declared in the ETA.

(2) Basic manufacturing process

The basic manufacturing process shall be described in sufficient detail to support the proposed factory production control methods.

Components for cold storage building and building envelope kits are usually manufactured using conventional techniques. Any critical process or treatment of the components affecting performance shall be highlighted.

(3) Product and materials specifications

- Detailed drawings (including manufacturing tolerances and drawings).
- Incoming (raw) materials specifications and declarations (see §8.2.1.1.2.2).
- References to European and/or international standards or appropriate specifications.
- ETA-holder's (or suppliers') datasheets.

(4) Test plan

The ETA-holder and the approval body issuing the ETA shall agree an FPC test plan. An agreed test plan is necessary as current standards relating to quality management systems (Guidance Paper B, EN ISO 9001, etc), do not ensure that the product specification remains unchanged, and they cannot address the technical validity of the type or frequency of checks / tests.

The validity of the type and frequency of checks/tests conducted during production and on the final product shall be considered. This shall include the checks conducted during manufacture on properties that cannot be inspected at a later stage, and for checks on the final product.

The following tables show properties that should be controlled and minimum frequencies of control, but, for the purposes of FPC, the ETA-holder may adopt alternative test methods, provided that they give sufficient assurance of the property controlled.

The tables 8.1 and 8.2 show the characteristics that need checking during FPC (as far as relevant). The results of these checks shall be registered by the ETA-holder. The test methods should correspond to those included in the technical specification, but different equipment may be used, as long as correlation can be established. The ETA-holder may also use external laboratories for these tests.

The tables below foresee minimum requirements. In many cases, constituent materials (e.g. insulating core, adhesives) or components (e.g. building hardware, profiles) will be supplied by other manufacturers to the ETA-holder. In those cases, it is very likely that the supplier performs FPC on those constituent materials or components. If that is the case, those suppliers should submit the relevant records to the ETA-holder.

Depending on the nature of the constituent material or component (significant influence on health and safety of the kit or not) and the evidence provided (e.g. supported by a third party certificate of conformity), the Approval body (and the Notified Body) will, in most cases, accept the evidence provided, although alternative verifications on the incoming products may then still be required (e.g. one verification per delivery). If no such evidence is available, the ETA-holder's FPC will be required to (at least) comply with the tables below. Approval bodies should refer to prEN 14509 for guidance as far as the composite panels are concerned.

Table 8.1: Properties and minimum frequencies of control – Composite panels and structural components

Property	Indicative test method ¹⁴	Threshold value (if any)	Minimum number of Samples	Minimum number of Tests
Properties of structural components				
Structural profiles, framework, etc.				
Structural connections				
Properties of the core material				
Density	§5.2.7.3	Conformity with ETA specification	3	1 every shift
Properties of the face material				
Thickness	§5.2.7.3	Conformity with ETA specification	3	Every delivery ¹⁵
Tensile strength	§5.2.7.2			
Properties of the adhesives*				
Coverage (spread)	-	ETA-Holder's declaration	-	Continuously
Density or viscosity	EN 542 or EN 12092	ETA-Holder's declaration	-	1 every shift
Setting time, maximum open time or working life (pot life)	ISO 10364 EN 1364	Supplier's declaration	-	1 every shift
Properties of the panels				
Dimensions	§5.2.7.3	Conformity with ETA specification	1	1 every shift
Compressive and tensile strength	§5.2.4.2		3	1 every 5 shifts ¹⁶
Shear strength	§5.2.7.2		1	1 every 10 shifts
Thermal performance	EN 12664, EN 12667 or EN 12939		1	1 every week
Panel lock system**	***		ETA-Holder's declaration	1
<p>* Only if an adhesive is used in manufacturing the composite panel ** Only if a panel lock system is part of the ETA-applicant's kit *** The panel lock system shall be tested in accordance with the following provisions: A sample, (250 ± 5) x (250 ± 5) mm², made up of equal parts of two adjacent panel sections, incorporating a lock and receiver, shall be locked together and then pulled apart by applying a gradually increasing force. The force, necessary to achieve separation shall be measured and recorded.</p>				

The ETA-holder and the notified body shall agree on which cold storage doors or gates (or door assemblies) the tests as given in table 8.2 should be conducted (as far as relevant).

¹⁴ The ETA-holder may adopt alternative test methods

¹⁵ Or Certificate of supplier

¹⁶ Where production volumes are below 2000 m² per shift, the ETA-holder shall test every 2000 m² or at least every three months.

Table 8.2: Properties and minimum frequencies of control – Doors, gates windows, roof windows and rooflights and panels with transparent surfaces*

Characteristic	Minimum frequency of testing for manufacturers of Cold storage building or building envelope kits**
ER2 - Reaction to fire	-
ER2 – Resistance to fire	-
ER3 - Food safety (only design aspects)	Every door and gate
ER3 – Food safety (food contact material aspects)	-
ER3 - Release of Dangerous substances	-
ER3 - Water tightness	-
ER4 - Automatic devices	-
ER4 – Impact resistance	1 every year
ER4 - Load-bearing capacity of safety devices	1 every year
ER4 - Mechanical resistance	1 every year
ER4 - Power operation	1 every year
ER4 - Resistance to wind (caused by air pressure)	1 every year
ER4 - Safe opening	1 every year
ER5 - Acoustic performance	-
ER6 - Air permeability	3 every year
ER6 - Radiation properties	-
ER6 - Thermal resistance	-
Durability - Materials	-
Durability - Mechanical resistance	-
Durability - Performance characteristics of non-pedestrian doors and gates	-
Durability - Resistance to specific environments	-
Serviceability - Automatic opening and / or closing devices	-
Serviceability - Mechanical durability	-
Serviceability - Operating forces	-
Serviceability - Behaviour between different climates	-
Serviceability - Defrost provisions	-
Identification	Every door and gate
<p>* Only of doors are part of the ETA-applicant's kit ** As a minimum, these verifications should only be performed on the most onerous door type (or door assembly), i.e. the door type (or door assembly) that is expected to perform worst when tested. Manufacturers will normally perform a range of indirect in-process verifications and verifications on the finished products and they should be encouraged to maintain those.</p>	

8.4 CE-MARKING AND INFORMATION

8.4.1 General

The ETA shall indicate the information to accompany the CE-marking. In accordance with EC Guidance Paper D, the required information to accompany the symbol "CE" is:

- a) identification number of the notified body
- b) name / address of the ETA-holder for the kit
- c) date of the marking
- d) number of the EC Certificate of Conformity
- e) number of ETA
- f) reference to this ETA-Guideline
- g) indication to clarify the intended use
- h) designation code for relevant performance characteristics, as far as they are not specified in the ETA

Note: g) and h) will not necessarily be given in the marking itself, but on the declaration.

8.4.2 Example of CE-Marking

8.4.2.1 For cold storage building envelope and building kits



"CE"-symbol

Number of Notified Body

Name and address of the ETA-holder or his representative established in the EEA and of the plant where the product was manufactured

Two last digits of year of affixing CE Marking
 Number of EC certificate of conformity

ETA Number
 ETAG Reference

Relevant performance characteristics and/or designation code*

8.4.2.2 For extension or replacement components of cold storage building envelope and building kits

For components put on the market separately for incorporation into an existing assembled (previously put onto the market) cold storage building envelope or building, i.e. for extension or repair of an existing cold storage building envelope or building (remedial or refurbishment), the CE Marking of the component shall be as follows:

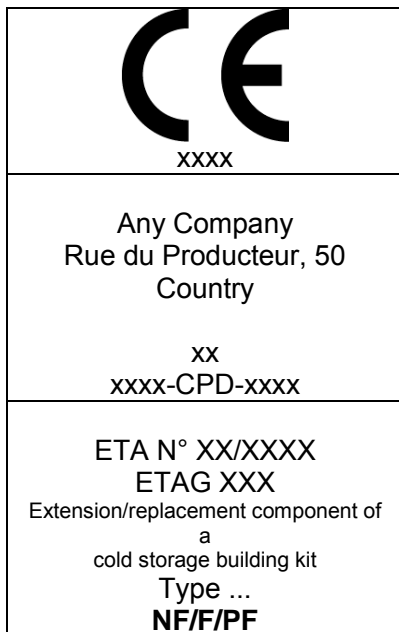

"CE"-symbol

Number of Notified Body

Name and address of the ETA-holder or his representative established in the EEA and of the plant where the product was manufactured

Two last digits of year of affixing CE Marking
 Number of EC certificate of conformity

ETA Number
 ETAG Reference

Relevant performance characteristics and/or designation code*

*Notes:

- If the ETA provides all the information regarding the performance characteristics, then reference to the ETA is sufficient.
- If the ETA covers more than one type of cold storage building envelope and building kit, and the

type designation provides all the information regarding the performance characteristics, then reference to the ETA and the relevant type is sufficient.

- Only when the above two options do not provide all the necessary information regarding the mandated performance characteristics (table 4.1), then additional information regarding the performance characteristics needs to accompany the CE Marking.
- The CE Marking shall always provide information related to the Foodstuff Directive (See §2.2.4).

8.4.3 Location of CE-Marking

The CE-Marking shall be affixed on the accompanying EC Declaration of conformity.

Section Four: ETA CONTENT

9 THE ETA-CONTENT

See this ETA-Guideline, Part 1, Section four, Chapter 9.

ANNEX A
COMMON TERMINOLOGY AND ABBREVIATIONS

See this ETA-Guideline, Part 1, Annex A

ANNEX B

SPECIFIC TERMINOLOGY AND ABBREVIATIONS RELATED TO THE PRODUCTS AND THEIR INTENDED USE COVERED BY THIS GUIDELINE

See this ETA-Guideline, Part 1, Annex B
Additional specific terminology, specific for this Part are:

Note: All definitions were taken from DIS/ISO 6707-1, unless indicated.

Balustrade (baluster guardrail system (picket railing system, baluster railing system)):
Protective barrier system consisting of posts and rows of balusters capped by top rail or hand rail or both, and bottom rail if any

Barrier
Element or structure, including parapet, fence, and guardrail, often, but not necessarily, incorporating infilling, to prevent people from falling, to bar passage, to prevent access, and to retain, stop, guide, or control the movement of people

Beam:
Structural member for carrying loads between or beyond points of support, usually narrow in relation to its length and horizontal or nearly so

Bracing:
System of structural members, usually diagonal, which acts in compression or tension and stiffen a structure

Bracket:
Support projecting horizontally from a vertical surface

Column:
Structural member of slender form, usually vertical, that transmits to its base the forces primarily in compression that are applied to it

Conduit:
Pipe, channel or tunnel for conveying liquids or gases or containing electric wires or cables

Damp proofing membrane:
Factory made flexible sheet made of bitumen material or composites including bitumen, plastics or rubber or composites thereof, used on or under floors or ground slabs intended to prevent liquid water not under hydrostatic pressure passing from the ground into the internal environment. This can also include use in walls.

Duct:
Space formed for the passage of air, gases, cables, pipes and other items

Eaves:
Lower edge of a pitched roof or edge of a flat roof

Flashing:
Strip of an impervious sheet of material, usually to protect a joint from rainwater entry

(Floor) slab:
Slab of large area that performs the function of a structural floor

Foundation:

Construction for transmitting forces to the supporting ground

Guardrail (guardrail system, guarding (railing system, railing)):

Component intended to retard, stop, or guide people and providing protection for building users against accidental fall, located at or near outer edge of stair, ramp, landing, platform, deck, hatchway, man hole, floor opening, or accessible roof; at perimeter of opening or accessible area, such as stair opening; or at location at which operating condition requires access limitation to designated area

Girder:

Large main beam that is solid and comprises top and bottom chords and either a solid or open web or webs that support primary or secondary members

Joist:

One of a series of parallel beams, usually horizontal

Lattice girder:

Truss with parallel or nearly parallel upper and lower structural chord members that have connecting diagonal structural web members

Loading bay:

Recess containing a platform for the loading and unloading of vehicles

Party wall:

A wall between two buildings of different ownership or occupation

Pipe:

Hollow, circular piece of metal or other suitable material, the size of which is usually designated by its nominal size as influenced by its inside diameter and the thickness of the material

Purlin:

Beam parallel to the eaves that gives intermediate support to rafters or roofing

Rafter:

One of a series of inclined structural members that supports roofing in a pitched roof

Rainwater gutter:

Channel for collecting and draining rainwater from a roof

Rainwater down-pipes:

Pipes fitted to a gutter to the drainage system or sewer [EN 607]

Roof truss:

One of a series of triangulated plane frames used to support a roof

Roof window:

Construction for closing an opening in the plane of a pitched roof, which admits light and which may provide ventilation

Rooflight:

Construction for closing an opening in a roof, intended primarily for lighting and consisting of a frame and glazing

Separating wall (or floor):

Wall (or floor) that separates adjoining spaces or buildings, for which regulatory requirements exist

Service duct:

Duct that provides activity space for inspection and maintenance

Service:

System to convey water, gas, warm air, electricity or waste

Shear wall:

Wall for resisting lateral forces in its plane

Soffit:

Exposed horizontal or sloping under-surface of any form of construction works

Solid floor:

Floor that comprises a floor slab without voids or fillers

Storey:

Space between two consecutive floors or between a floor and a roof

Structural components:

Components of a building kit that may be manufactured as members, structural frames or as completely prefabricated building elements [EN 1990]

Structural connection/joint:

Construction formed by the adjacent parts of two or more structural components or members [EN 1990]

Structural member:

Physically distinguishable part of a structure, e.g. column, beam, slab,... [EN 1990]

Structural system:

Loadbearing members of a building and the way these members function together [EN 1990]

Strut:

Structural member intended to resist axial forces acting in compression

Stud:

One of a series of vertical members in a partition or structural members in a loadbearing wall

Suspended floors:

Floor structures with a free span between supports

Suspended ceiling:

Ceiling hung at a distance from the floor or roof above

Tie:

Structural member intended to resist axial forces acting in tension

Truss:

Braced triangulated frame designed to act as a beam

Water vapour control layer:

Factory made flexible sheet made of bitumen material or composites including bitumen, plastics or rubber or composites thereof, intended to prevent or control the passage of water and water vapour from one section of a building to another or between the interior and exterior of the building. These may have different permeabilities to water vapour depending on the specific use.

Walkway:

Construction that provides elevated lateral access

Wind brace:

Structural member used in wind bracing

Wind bracing:

Bracing designed to resist wind forces

ANNEX C

LIST OF REFERENCE DOCUMENTS

See this ETA-Guideline, Part 1, Annex C
Additional reference documents, specific for this Part are:

ETAG 008	Prefabricated Stair Kits
Draft ETA-Guideline xx2	Prefabricated Building Units
EN 490:1994	Concrete roofing tiles and fittings for roof covering and wall cladding - Product specifications
EN 492:1994	Fibre-cement slates and fittings - Product specification and test methods
EN 494:1994	Fibre-cement profiled sheets and fittings - Product specification and test methods
EN 516:1995	Prefabricated accessories for roofing - Installations for roof access - Walkways, treads and steps - Product specification and test methods
EN 517:1995	Prefabricated accessories for roofing - Roof safety hooks - Product specification and test methods
EN 534:1998	Corrugated bitumen sheets - Product specification and test methods
EN 544:1998	Bitumen shingles with mineral and/or synthetic reinforcement - Product specification and test methods
EN 607:1995	Eaves gutters and fittings made of PVC-U - Definitions, requirements and testing
EN 612:1996	Eaves, gutters and rainwater down-pipes of metal sheet - Definitions, classifications and requirements
EN 1013-1:1997	Light transmitting profiled plastic sheeting for single skin roofing, wall and ceiling finishes - Part 1: General requirements and test methods
EN 1304:1998	Clay tiles and fittings for discontinuous laying - Product definitions and specifications
EN 1873:2005	Prefabricated accessories for roofing - Individual rooflights of plastics with upstands - Product specification and test methods
EN 12326-1:2004	Slate and stone products for discontinuous roofing and cladding - Part 1: Product specification
EN 12467:2000	Fibre-cement flat sheets and fittings - Product specification and test methods
EN 12865:2001	Hygrothermal performance of building components and building elements - Determination of the resistance of external wall systems to driving rain under pulsating air pressure
EN 12951:2003	Prefabricated accessories for roofing - Permanently fixed roof ladders - Product specification and test methods
EN 13707:2005	Flexible sheets for waterproofing - Reinforced bitumen sheets for roof waterproofing - Definitions and characteristics
EN 13859-1:2005	Flexible sheets for waterproofing - Definitions and characteristics of underlays - Part 1: Underlays for discontinuous roofing
EN 13859-2:2005	Flexible sheets for waterproofing - Definitions and characteristics of underlays - Part 2: Underlays for walls
EN 13956:2005	Flexible sheets for waterproofing - Plastic and rubber sheets for roof waterproofing - Definitions and characteristics
EN 13967:2005	Flexible sheets for waterproofing - Plastic and rubber damp proof membranes - Definitions and characteristics
EN 13969:2005	Flexible sheets for waterproofing - Bitumen damp proof membranes - Definitions and characteristics
EN 13970:2005	Flexible sheets for waterproofing - Bitumen water vapour control layers - Definitions and characteristics

EN 13984:2005	Flexible sheets for waterproofing - Plastic and rubber vapour control layers - Definitions and characteristics
EN 20140-9:1994	Acoustics - Measurement of sound insulation in buildings and of building elements - Laboratory measurement of room-to-room airborne sound insulation of a suspended ceiling with a plenum above it
EN 20140-10:1992	Acoustics - Measurement of sound insulation in buildings and of building elements - Laboratory measurement of airborne sound insulation of small building elements
EN ISO 140-3:1995	Acoustics - Measurement of sound insulation in buildings and of building elements - Laboratory measurement of airborne sound insulation of building elements
EN ISO 140-4:1998	Acoustics - Measurement of sound insulation in buildings and of building elements - Field measurements of airborne sound insulation between rooms
EN ISO 140-5:1998	Acoustics - Measurement of sound insulation in buildings and of building elements - Field measurements of airborne sound insulation of facade elements and facades
EN ISO 140-6:1998	Acoustics - Measurement of sound insulation in buildings and of building elements - Laboratory measurements of impact sound insulation of floors
EN ISO 140-7:1998	Acoustics - Measurement of sound insulation in buildings and of building elements - Field measurements of impact sound insulation of floors
EN ISO 140-8:1998	Acoustics - Measurement of sound insulation in buildings and of building elements - Laboratory measurements of the reduction of transmitted impact noise by floor coverings on a heavyweight standard floor
EN ISO 140-12:2000	Acoustics - Measurement of sound insulation in buildings and of building elements - Laboratory measurement of room-to-room airborne and impact sound insulation of an access floor
EN ISO 354:2003	Acoustics - Measurement of sound absorption in a reverberation room
EN ISO 717-1:1997	Acoustics - Rating of sound insulation in buildings and of building elements - Airborne sound insulation
EN ISO 717-2:1997	Acoustics - Rating of sound insulation in buildings and of building elements - Impact sound insulation
EN ISO 11654:1997	Acoustics - Sound absorbers for use in buildings - Rating of sound absorption
ISO 6707-1:2004	Glossary of building and civil engineering terms – Part 1: General terms
prEN 14963	Prefabricated accessories for roofing - Continuous plastic rooflights with upstand - Product specification and test methods
prEN 14964	Rigid underlays
prEN 14967	Flexible sheets for waterproofing - Plastic damp proof courses - Definitions and characteristics
prEN 14909	Flexible sheets for waterproofing - Bitumen damp proof courses - Definitions and characteristics
prEN ISO 140-11	Measurement of sound insulation in buildings and of building elements - Part 11: Laboratory measurements of the reduction of transmitted impact noise by floor coverings on a lightweight floor
ISO/DIS 12055	Building construction – Guardrail systems and rails for buildings