



---

European Organisation for Technical Approvals  
Europäische Organisation für Technische Zulassungen  
Organisation Européenne pour l'Agrément Technique

---

## **ETAG 029**

Edition April 2013

**GUIDELINE FOR EUROPEAN TECHNICAL APPROVAL  
of**

**METAL INJECTION ANCHORS FOR USE IN MASONRY**

---

**Annex C : DESIGN METHODS FOR ANCHORAGES**

---

**EOTA  
Kunstlaan 40 Avenue des Arts  
B - 1040 Brussels**

## TABLE OF CONTENTS

Introduction .....	3
<b>C.1 Scope .....</b>	<b>3</b>
C.1.1 Type of anchors, anchor groups and number of anchors .....	3
C.1.2 Member .....	3
C.1.2.1 Solid and hollow or perforated masonry .....	3
C.1.2.2 Autoclaved aerated concrete .....	3
C.1.3 Type and direction of load .....	3
<b>C.2 Terminology and symbols .....</b>	<b>3</b>
<b>C.3 Design and safety concept .....</b>	<b>4</b>
C.3.1 General .....	4
C.3.2 Ultimate limit state .....	4
C.3.2.1 Design resistance .....	4
C.3.2.2 Partial safety factors for resistances .....	4
C.3.2.2.1 Failure (rupture) of the metal part .....	4
C.3.2.2.2 Failure of the injection anchor .....	4
C.3.3 Serviceability limit state .....	5
<b>C.4 Static analysis .....</b>	<b>5</b>
C.4.1 Loads acting on anchors .....	5
C.4.2 Shear loads with or without lever arm .....	5
<b>C.5 Ultimate limit state .....</b>	<b>6</b>
C.5.1 General .....	6
C.5.2 Design method A for use in masonry .....	6
C.5.2.1 Resistance to tension loads .....	6
C.5.2.1.1 Required proofs .....	6
C.5.2.1.2 Failure of the metal part .....	6
C.5.2.1.3 Pull-out failure of the anchor .....	6
C.5.2.1.4 Brick breakout failure .....	7
C.5.2.1.5 Pull out of one brick .....	7
C.5.2.1.6 Influence of joints .....	7
C.5.2.2 Resistance to shear loads .....	8
C.5.2.2.1 Required proofs .....	8
C.5.2.2.2 Failure of the metal part, shear load without lever arm .....	8
C.5.2.2.3 Failure of the metal part, shear load with lever arm .....	8
C.5.2.2.4 Local brick failure .....	8
C.5.2.2.5 Brick edge failure .....	9
C.5.2.2.7 Influence of joints .....	10
C.5.2.3 Resistance to combined tension and shear loads .....	10
C.5.3 Design method B for use in masonry .....	10
<b>C.6 Serviceability limit state .....</b>	<b>10</b>
C.6.1 Displacements .....	10
C.6.2 Shear load with changing sign .....	10

## **Introduction**

The design method for anchorages is intended to be used for the design of anchorages under due consideration of the safety and design concept within the scope of the European Technical Approvals of injection anchors for use in masonry.

The design method given in Annex C is based on the assumption that the required tests for assessing the admissible service conditions given in this Guideline have been carried out. The use of other design methods will require reconsideration of the necessary tests.

The proof of local transmission of the anchor loads into the masonry units is delivered by using the design methods described in this document. Proof of transmission of anchor loads to the supports of the masonry members shall be done by the engineer of the construction works.

### **C.1 Scope**

#### **C.1.1 Type of anchors, anchor groups and number of anchors**

The design method applies to the design of injection anchors in masonry units of clay, calcium silicate, normal weight concrete, light weight concrete, autoclaved aerated concrete (AAC) or other similar materials using anchors which fulfil the requirements of this Guideline. The characteristic values are given in the relevant approval.

The design method is valid for single anchors and anchor groups with two or four anchors. In an anchor group only anchors of the same type, size and length shall be used.

#### **C.1.2 Member**

##### **C.1.2.1 Solid and hollow or perforated masonry**

The masonry member shall be of solid or hollow or perforated masonry units made of clay or calcium silicate, normal weight concrete or light weight concrete.

The detailed information of the corresponding base material is given in the approval, e.g. base material, size of units, normalised compressive strength; volume of all holes (% of the gross volume); volume of any hole (% of the gross volume); minimum thickness in and around holes (web and shell); combined thickness of webs and shells (% of the overall width).

##### **C.1.2.2 Autoclaved aerated concrete**

The autoclaved aerated concrete member shall be according to EN 771-4:2011 [2] or EN 12 602:2008 [3].

#### **C.1.3 Type and direction of load**

This ETAG applies only to anchors subject to static or quasi-static actions in tension, shear or combined tension and shear or bending. The anchors may be used in areas with very low seismicity according to EN 1998-1:2004 + AC 2009 [15].

### **C.2 Terminology and symbols**

The explanations of the notations and symbols are given in the general part of the ETAG.

### C.3 Design and safety concept

#### C.3.1 General

The design of anchorages shall be in accordance with the general rules given in EN 1990:2002 + A1:2005 / AC:2010 [11]. It shall be shown that the value of the design actions  $S_d$  does not exceed the value of the design resistance  $R_d$ .

$$S_d \leq R_d \quad (C.3.1)$$

$S_d$  = value of design action  
 $R_d$  = value of design resistance

**Actions** to be used in design may be obtained from national regulations or in the absence of them from the relevant parts of EN 1991:2002 + AC 2009 [12].

The partial safety factors for actions may be taken from national regulations or in the absence of them according to EN 1990:2002 + A1:2005 / AC:2010 [11].

The design **resistance** is calculated as follows:

$$R_d = R_k / \gamma_M \quad (C.3.2)$$

$R_k$  = characteristic resistance of a single anchor or an anchor group  
 $\gamma_M$  = partial safety factor for material

#### C.3.2 Ultimate limit state

##### C.3.2.1 Design resistance

The design resistance is calculated according to Equation (C.3.2).

##### C.3.2.2 Partial safety factors for resistances

In the absence of national regulations the following partial safety factors may be used:

###### C.3.2.2.1 Failure (rupture) of the metal part

Tension loading:

$$\gamma_{Ms} = \frac{1,2}{f_{yk} / f_{uk}} \quad 1,4 \quad (C.3.3a)$$

Shear loading of the anchor with and without lever arm:

$$\gamma_{Ms} = \frac{1,0}{f_{yk} / f_{uk}} \quad 1,25 \quad f_{uk} \leq 800 \text{ N/mm}^2 \quad (C.3.3b)$$

and  $f_{yk}/f_{uk} \leq 0,8$

$$\gamma_{Ms} = 1,5 \quad \text{or} \quad f_{uk} > 800 \text{ N/mm}^2$$
$$\text{or} \quad f_{yk}/f_{uk} > 0,8$$

###### C.3.2.2.2 Failure of the injection anchor

a) For use in masonry

$$\gamma_{Mm} = 2,5$$

b) For use in autoclaved aerated concrete

$$\gamma_{MAAC} = 2,0$$

### C.3.3 Serviceability limit state

In the serviceability limit state it shall be shown that the displacements occurring under the characteristic actions (see C.6) are not larger than the permissible displacements. The permissible displacements depend on the application in question and shall be evaluated by the designer.

In this check the partial safety factors on actions and on resistances may be assumed to be equal 1,0.

### C.4 Static analysis

#### C.4.1 Loads acting on anchors

Distribution of loads acting on anchors shall be calculated according to the theory of elasticity.

For steel failure under tension and shear and for pull-out failure under tension the load acting on the highest loaded anchor shall be determined.

In case of brick edge failure the shear load is assumed to act on the anchor(s) closest to the edge.

#### C.4.2 Shear loads with or without lever arm

Shear loads acting on an anchor may be assumed to act without lever arm if all of the following conditions are fulfilled:

1. The fixture shall be made of metal and in the area of the anchorage be fixed directly to the base material without an intermediate layer or with a levelling layer of mortar with a compressive strength  $\geq 30 \text{ N/mm}^2$  and a thickness  $\leq d/2$ .
2. The fixture is in contact with the anchor over a length of at least  $0,5 \cdot t_{\text{fix}}$ .
3. The diameter  $d_f$  of the hole in the fixture is not greater than the values  $d_f$  given in Table C.4.1.

If these conditions are not fulfilled the lever arm is calculated according to Equation (C.4.1) (see Figure C.4.1).

$$l = a_3 + e_1 \tag{C.4.1}$$

- $e_1$  = distance between shear load and surface of the member
- $a_3$  =  $0,5 \cdot d$
- $d$  = diameter of the anchor bolt

**Table C.4.1 – Diameter of clearance hole in the fixture**

Outside anchor bolt or thread diameter $d$ or $d_{\text{nom}}$ (mm)	6	8	10	12	14	16	18	20	22	24	30
Diameter of clearance hole in the fixture $d_f$ (mm)	7	9	12	14	16	18	20	22	24	26	33

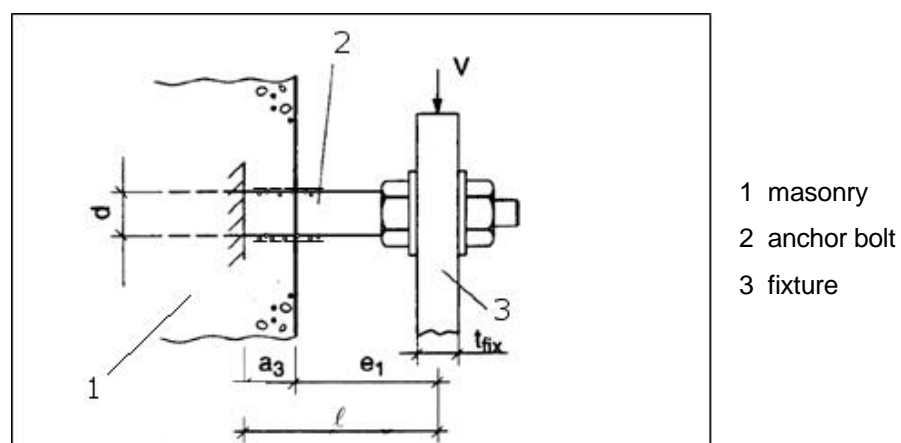

**Figure C.4.1 – Definition of lever arm**

## C.5 Ultimate limit state

### C.5.1 General

For the design of anchorages in the ultimate limit state, there are two different design methods available. The general design method A is described in C.5.2 and a simplified design method B is given in C.5.3.

Spacing, edge distance as well as thickness of member shall not remain under the given minimum values in the approval.

### C.5.2 Design method A for use in masonry

In design method A it shall be shown that Equation (C.3.1) is observed for all loading directions (tension, shear) as well as all failure modes (steel failure, pull-out failure and brick failure).

In case of a combined tension and shear loading (oblique loading) the condition of interaction according to C.5.2.3 shall be observed.

#### C.5.2.1 Resistance to tension loads

##### C.5.2.1.1 Required proofs

Failure of the metal part	$N_{Sd}^h \quad N_{Rk,s} / \gamma_{Ms}$	C.5.2.1.2
Pull-out failure of the anchor	$N_{Sd}^h \quad N_{Rk,p} / \gamma_{Mm}$	C.5.2.1.3
Brick breakout failure	$N_{Sd} \quad N_{Rk,b} / \gamma_{Mm}$ $N_{Sd}^g \quad N_{Rk}^g / \gamma_{Mm}$	C.5.2.1.4
Pull out of one brick	$N_{Sd} \quad N_{Rk,pb} / \gamma_{Mm}$	C.5.2.1.5
Influence of joints	$N_{Sd} \quad \alpha_j N_{Rk,p} / \gamma_{Mm}$ $N_{Sd} \quad \alpha_j N_{Rk,b} / \gamma_{Mm}$	C.5.2.1.6

For anchorages in AAC the partial safety factor  $\gamma_{MAAC}$  is to be used instead of  $\gamma_{Mm}$ .

##### C.5.2.1.2 Failure of the metal part

The characteristic resistance of an anchor in case of failure of the metal part,  $N_{Rk,s}$ , is given in the relevant approval.

The value of  $N_{Rk,s}$  is obtained from Equation (C.5.1)

$$N_{Rk,s} = A_s \cdot f_{uk} \quad [N] \quad (C.5.1)$$

##### C.5.2.1.3 Pull-out failure of the anchor

The characteristic resistance in case of failure by pull-out of the anchor,  $N_{Rk,p}$ , shall be taken from the relevant approval.

### C.5.2.1.4 Brick breakout failure

The characteristic resistance of one anchor in case of brick breakout failure  $N_{Rk,b}$  and the corresponding values for spacing and edge distance  $s_{cr,II}$ ,  $s_{cr}$ , and  $c_{cr}$  or  $c_{min}$  are given in the relevant approval.

The characteristic resistance of a group of two or four injection anchors  $N_{Rk}^g$  and the corresponding values for spacing and edge distance  $s_{min,II}$ ,  $s_{min}$ , and  $c_{min}$  are given in the relevant approval. On the safe side the characteristic resistance of a group with spacing smaller than  $s_{cr,II}$  and  $s_{cr}$ , can be assumed to be at least the characteristic resistance of a corresponding single anchor.

### C.5.2.1.5 Pull out of one brick

The characteristic resistance of an anchor or a group of anchors in case of pull out of one brick,  $N_{Rk,pb}$ , is calculated as follows:

Vertical joints are designed not to be filled with mortar

$$N_{Rk,pb} = 2 \cdot l_{brick} \cdot b_{brick} (0,5 \cdot f_{vko} + 0,4 \cdot \sigma_d) \quad (C.5.2)$$

Vertical joints are designed to be filled with mortar

$$N_{Rk,pb} = 2 \cdot l_{brick} \cdot b_{brick} (0,5 \cdot f_{vko} + 0,4 \cdot \sigma_d) + b_{brick} \cdot h_{brick} \cdot f_{vko} \quad (C.5.3)$$

with:

- $N_{Rk,pb}$  = characteristic resistance for pull out of one brick
- $l_{brick}$  = length of the brick
- $b_{brick}$  = breadth of the brick
- $h_{brick}$  = height of the brick
- $\sigma_d$  = design compressive stress perpendicular to the shear
- $f_{vko}$  = initial shear strength according to EN 1996-1-1, Table 3.4

Brick type	Mortar strength	$f_{vko}$ [N/mm <sup>2</sup> ]
Clay brick	M2,5 to M9	0,2
	M10 to M20	0,3
All other types	M2,5 to M9	0,15
	M10 to M20	0,2

### C.5.2.1.6 Influence of joints

If the joints of the masonry are not visible the characteristic resistances  $N_{Rk,p}$  and  $N_{Rk,b}$  have to be reduced by the factor  $\alpha_j = 0,75$ .

If the joints of the masonry are visible (e.g. unplastered wall), the following has to be taken into account:

- The characteristic resistance  $N_{Rk,p}$  and  $N_{Rk,b}$  may be used only if the wall is designed such that the joints are to be filled with mortar.
- If the wall is designed such that the joints are not to be filled with mortar then the characteristic resistance  $N_{Rk,p}$  and  $N_{Rk,b}$  may be used only if the minimum edge distance  $c_{min}$  to the vertical joints is observed. If this minimum edge distance  $c_{min}$  cannot be observed then the characteristic resistance  $N_{Rk,p}$  and  $N_{Rk,b}$  has to be reduced by the factor  $\alpha_j = 0,75$ .

## C.5.2.2 Resistance to shear loads

### C.5.2.2.1 Required proofs

Failure of the metal part, shear load without lever arm	$V_{Sd}^h \quad V_{Rk,s} / \gamma_{Ms}$	C.5.2.2.2
Failure of the metal part, shear load with lever arm	$V_{Sd}^h \quad V_{Rk,s} / \gamma_{Ms}$	C.5.2.2.3
Local brick failure	$V_{Sd} \quad V_{Rk,b} / \gamma_{Mm}$ $V_{Sd}^g \quad V_{Rk}^g / \gamma_{Mm}$	C.5.2.2.4
Brick edge failure	$V_{Sd} \quad V_{Rk,c} / \gamma_{Mm}$ $V_{Sd}^g \quad V_{Rk}^g / \gamma_{Mm}$	C.5.2.2.5
Pushing out of one brick	$V_{Sd} \quad V_{Rk,pb} / \gamma_{Mm}$	C.5.2.2.6
Influence of joints	$V_{Sd} \quad \alpha_j V_{Rk,b} / \gamma_{Mm}$ $V_{Sd} \quad \alpha_j V_{Rk,c} / \gamma_{Mm}$	C.5.2.2.7

For anchorages in AAC the partial safety factor  $\gamma_{MAAC}$  is to be used instead of  $\gamma_{Mm}$ .

#### C.5.2.2.2 Failure of the metal part, shear load without lever arm

The characteristic resistance of an anchor in case of failure of the metal part due to shear load without lever arm  $V_{Rk,s}$  shall be taken from the relevant approval.

In case of no characteristic resistance is given in the ETA, the following equations may be applied.

$$V_{Rk,s} = 0,5 \cdot A_s \cdot f_{uk} \quad [N] \quad (C.5.4)$$

#### C.5.2.2.3 Failure of the metal part, shear load with lever arm

The characteristic resistance of an anchor in case of failure of the metal part due to shear load with lever arm  $V_{Rk,s}$  is given by Equation (C.5.5).

$$V_{Rk,s} = \frac{M_{Rk,s}}{\ell} \quad [N] \quad (C.5.5)$$

$\ell$  lever arm according to Equation (C.4.1)  
 $M_{Rk,s}$  to be taken from the relevant approval

#### C.5.2.2.4 Local brick failure

The characteristic resistance of one anchor in case of local brick failure  $V_{Rk,b}$  and the corresponding values for spacing and edge distance  $s_{cr,II}$ ,  $s_{cr}$  and  $c_{cr}$  or  $c_{min}$  are given in the relevant approval.

The characteristic resistance of a group of two or four injection anchors  $V_{Rk}^g$  and the corresponding values for spacing and edge distance  $s_{min,II}$ ,  $s_{min}$  and  $c_{min}$  are given in the relevant approval. On the safe side the characteristic resistance of a group with spacing smaller than  $s_{cr,II}$  and  $s_{cr}$  can be assumed to be at least the characteristic resistance of a corresponding single anchor.



### C.5.2.2.5 Brick edge failure

The characteristic resistance for an anchor in the case of brick edge failure  $V_{Rk,c}$  and the corresponding values for spacing and edge distance  $s_{min,II}$ ,  $s_{min}$ , and  $c_{min}$  are given in the relevant ETA.

In case no characteristic resistance is given in the ETA, the following equations may be applied.

For anchorages in solid masonry and AAC the following determination may be used:

$$V_{Rk,c} = k \cdot \sqrt{d_{nom}} \cdot (h_{nom} / d_{nom})^{0,2} \cdot \sqrt{f_b} \cdot c_1^{1,5} \quad [N] \quad (C.5.6)$$

with:

- $k$  = 0,25 if load direction is to the free edge  
= 0,45 if load direction is parallel to the free edge
- $c_1$  = edge distance closest to the edge in mm  
 $c_1 \geq c_{min}$

If the load is directed to the free edge and the wall is not designed such that the joints are filled with mortar (so no load transfer to other units in the wall is given) then the following conditions shall be fulfilled:

$$c_1 \geq h / 1,5$$

$$c_1 \geq h_{brick} / 3$$

- $d_{nom}$  outside diameter of the anchor in mm
- $h_{nom}$  overall anchor embedment depth in mm
- $f_b$  normalized mean compressive strength of masonry unit in  $N/mm^2$

For anchorages in hollow or perforated masonry the following values correspond to current experience and no further determination is required:

$V_{Rk,c,II} = 2,50 \text{ kN}$  if load direction is parallel to the free edge with  $c_{min} \geq 100 \text{ mm} \geq 6 d_0$  and  
if load direction is to the free edge with  $c_{min} \geq 250 \text{ mm}$

$V_{Rk,c} = 1,25 \text{ kN}$  if load direction is to the free edge with  $c_{min} \geq 100 \text{ mm}$

Intermediate values can be interpolated

The characteristic resistance of a group of two or four injection anchors  $V_{Rk,c}^g$  and the corresponding values for spacing and edge distance  $s_{cr,II}$ ,  $s_{cr}$ , and  $c_{cr}$  or  $c_{min}$  are given in the relevant approval. On the safe side the characteristic resistance of a group with spacing smaller than  $s_{cr,II}$  and  $s_{cr}$ , can be assumed to be at least the characteristic resistance of a corresponding single anchor.

### C.5.2.2.6 Pushing out of one brick

The characteristic resistance of an anchor or a group of anchors in case of pushing out of one brick on the free edge of a wall,  $V_{Rk,pb}$ , is calculated as follows:

$$V_{Rk,pb} = (2 \cdot l_{brick} \cdot b_{brick}) \cdot (0,5 \cdot f_{vko} + 0,4 \cdot \sigma_d) \quad (C.5.7)$$

with:

- $V_{Rk,pb}$  = characteristic resistance for pushing out of one brick
- $l_{brick}$  = length of the brick
- $b_{brick}$  = breadth of the brick
- $\sigma_d$  = design compressive stress perpendicular to the shear
- $f_{vko}$  = initial shear strength according to EN 1996-1-1, Table 3.4

Brick type	Mortar strength	$f_{vko}$ [ $N/mm^2$ ]
Clay brick	M2,5 to M9	0,2
	M10 to M20	0,3
All other types	M2,5 to M9	0,15
	M10 to M20	0,2

### C.5.2.2.7 Influence of joints

If the joints of the masonry with a designed thickness of 2 mm to 5 mm are not visible the characteristic resistances  $V_{Rk,b}$  have to be reduced by the factor  $\alpha_j = 0,75$ . Joints with a designed thickness  $> 5$  mm have to be designed such as a free edge.

If the joints of the masonry are visible (e.g. unplastered wall), the following has to be taken into account:

- The characteristic resistance  $V_{Rk,b}$  and  $V_{Rk,c}$  may be used only if the wall is designed such that the joints are to be filled with mortar.
- Joints which are not be filled with mortar have to be designed such as a free edge.

### C.5.2.3 Resistance to combined tension and shear loads

For combined tension and shear loads the following equations shall be satisfied:

$$\beta_N = 1,0 \quad (C.5.8.a)$$

$$\beta_V = 1,0 \quad (C.5.8.b)$$

$$\beta_N + \beta_V = 1,2 \quad \text{for solid masonry} \quad (C.5.8.c)$$

$$\beta_N + \beta_V = 1,0 \quad \text{for perforated or hollow masonry} \quad (C.5.8.d)$$

With  $\beta_N$  ( $\beta_V$ ) = ratio between design action and design resistance for tension (shear) loading.  
In Equation (C.5.7) the largest value of  $\beta_N$  and  $\beta_V$  for the different failure modes shall be taken (see C.5.2.1.1 and C.5.2.2.1).

### C.5.3 Design method B for use in masonry

Design method B is based on a simplified approach in which only one value for the design resistance  $F_{Rd}$  is given, independent of loading direction and mode of failure. The design resistance  $F_{Rd}$  is calculated by the lowest value under consideration of the characteristic resistances and the corresponding partial safety factors. The actual spacing and edge distance shall be equal to or larger than the values of  $s_{cr}$  and  $c_{cr}$ .  $F_{Rd}$ ,  $s_{cr}$  and  $c_{cr}$  are given in the relevant approval.

In case of shear load with lever arm the characteristic anchor resistance shall be calculated according to Equation (C.5.5). The smallest value of  $F_{Rd}$  or  $V_{Rk,s} / \gamma_{Ms}$  according to Equation (C.5.5) governs.

The characteristic resistance of an anchor or a group of anchors in case of pull-out or push out of one brick and the influence of joints shall be considered according to C.5.2.1.5, C.5.2.1.6, C.5.2.2.6 and C.5.2.2.7 in every application.

## C.6 Serviceability limit state

### C.6.1 Displacements

The characteristic displacement of the anchor under defined tension and shear loads shall be taken from the approval. It may be assumed that the displacements are a linear function of the applied load. In case of a combined tension and shear load, the displacements for the tension and shear component of the resultant load shall be geometrically added.

In case of shear loads the influence of the hole clearance in the fixture on the expected displacement of the whole anchorage shall be taken into account.

### C.6.2 Shear load with changing sign

If the shear loads acting on the anchor change their sign several times, appropriate measures shall be taken to avoid a fatigue failure of the anchor (e.g. the shear load shall be transferred by friction between the fixture and the base material (e.g. due to a sufficiently high permanent pre-stressing force).

Shear loads with changing sign can occur due to temperature variations in the fastened member (e.g. facade elements). Therefore, either these members are anchored such that no significant shear loads due to the restraint of deformations imposed to the fastened element will occur in the anchor or in shear loading with lever arm the bending stresses in the most stressed anchor  $\Delta\sigma = \max\sigma - \min\sigma$  in the serviceability limit state caused by temperature variations shall be limited to 100 N/mm<sup>2</sup> for steel.