

European Organisation for Technical Approvals
Europäische Organisation für Technische Zulassungen
Organisation Européenne pour l'Agrément Technique

Established pursuant to Annex II of the Council Directive 89/106 of 21 December 1988 on the approximation of laws, regulations and administrative provisions of Member States relating to construction products (Construction Products Directive)

ETAG 030

GUIDELINE FOR
EUROPEAN TECHNICAL APPROVAL
of

DOWELS FOR STRUCTURAL JOINTS

PART 1: GENERAL

Edition April 2013

This Guideline for European Technical Approval is established and published in accordance with Article 11 of the Construction Products Directive as a basis for the preparation and issue of European Technical Approvals in accordance with Article 9.1 of the Construction Products Directive.

European Technical Approvals are issued by Approval Bodies authorised and notified in accordance with Article 10 of the Construction Products Directive. These bodies are organized in EOTA.

The European Technical Approval, according to the Construction Products Directive, is a favourable technical assessment of the fitness for use of a construction product and the technical specification of the assessed product, serving as basis for the CE marking of this product when and where a harmonised standard according to the Directive is not or not yet available.

Due to technical innovation and the progress of the state of the art, Guidelines for technical approval might not reflect the latest developments and experiences gained in approval procedures. The reader of this Guideline is therefore advised to check with an EOTA member whether there are further provisions which have to be taken into account in the use of the Guideline.

Note: The copyright refers to the English reference version established by EOTA. For publications in accordance with Article 11.3 of the Construction Products Directive the national laws, regulations and administrative provisions of the Member State concerned are applicable.

Table of contents

1	Scope of the ETAG	3
1.1	Definition of the construction product	3
1.2	Intended use of the construction product	3
1.3	Assumed working life of the construction product	4
1.4	Terminology	4
1.4.1	Common terms relating to the Construction Products Directive	4
1.4.2	Specific terms used in this ETAG	5
1.5	Procedure in the case of a significant deviation from the ETAG	5
2	Assessment of fitness for use	6
2.1	Meaning of "fitness for use"	6
2.2	Elements of the assessment of fitness for use	6
2.3	Relationship of requirements to the product characteristics and methods of verification and assessment	6
2.4	Product characteristics which are relevant for the fitness for use	9
2.4.1	Essential Requirement 1: Mechanical resistance and stability	9
2.4.2	Essential Requirement 2: Safety in Case of Fire	18
2.4.3	Essential Requirement 3: Hygiene, Health and Environment	19
2.4.4	Essential Requirement 4: Safety in use	20
2.4.5	Essential Requirement 5: Protection against noise	20
2.4.6	Essential Requirement 6: Energy Economy and Heat Retention	20
3	Evaluation and attestation of conformity and CE marking	21
3.1	System of attestation of conformity	21
3.2	Tasks and responsibilities of the manufacturer and notified bodies	22
3.2.1	Tasks for the manufacturer	22
3.2.2	Tasks for notified body	23
3.3	CE marking and accompanying information	23
4	Assumptions under which the fitness for the intended use is assessed	24
4.1	Manufacture of the product	24
4.2	Packaging, transport, storage of the product	24
4.3	Installation of the product in the works	24
4.4	Use, maintenance, repair	24
5	Identification of the construction product	25
5.1	Means of identification	25
5.2	Product characteristics which are relevant for identification checking	25
5.2.1	Identification characteristic of the product (for steel used)	25
6	Format of ETAs issued on the basis of the ETAG	26
7	Reference documents	26
	Annex A DESIGN OF THE WORKS	27
	Annex B CONTROL PLAN	30
	Annex C ETA MODEL FOR DOWELS FOR STRUCTURAL JOINTS	31

1 Scope of the ETAG

This Guideline covers building products, dowels for structural joints or dowel connector, used to transfer shear loads across an expansion joint between building parts made of reinforced normal weight concrete.

Dowel connectors are structural components designed to allow free expansion of the joint while restraining relative displacements between two adjacent elements across the expansion joint with respect to one (or two) direction(s) perpendicular to the dowel axis.

This part of the ETAG only deals with dowel connectors that transmit static loads only and are not exposed to highly¹ aggressive agents in the environment.

1.1 Definition of the construction product

The dowel connectors covered by this ETA Guideline always consist of two main components:

- one (or several) bar(s) of rectangular, circular or elongated (egg-shaped) cross section, made of stainless or galvanised steel; tubes or hollow cross section bars are covered (Part M),
- corresponding sleeve(s) made of steel or synthetic material, into which the dowel bar(s) is (are) inserted (Part F).

Depending on design choices, reinforcement bars or steel plates may also be included with the dowel connector.

The dowel bar (Part M) is inserted into a sleeve (Part F) on the one side of the joint, and embedded in concrete on the opposite side; such setting allows free expansion of the joint and shear stress transmission.

The two components of a dowel connector are manufactured separately in the factory and assembled on the construction site into an expansion joint between concrete elements.

1.2 Intended use of the construction product

The function of a dowel connector is to transmit shear forces between the concrete elements of the parts of the works connected. The shear forces are transmitted through a steel dowel to a concrete element by means of reinforcements set near the dowel in an appropriate way (or by reinforcements fixed to the dowel connector before using). The concrete elements to be connected shall be at least 15 cms thick.

A dowel for structural joint shall be able to perform this function both in and internal environment and in a normal external environment, including special cases where the dowels support a floor providing a specified level of fire resistance.

Dowels that may be subjected to dynamic loading (earthquake loading in the majority of cases), or repeated loading in such a way as to cause fatigue-related phenomena, or dowels that may be subjected to an aggressive environment liable to cause accelerated corrosion, will be covered by further parts of this ETAG.

Only families A1 and B1 with steel sleeves can be used as a stability component between two blocks of a building, i.e. they can transmit lateral forces.

The intended use of a dowel as specified in an ETA may vary within a range of possibilities, from a dowel transmitting shear forces in a normal environment without providing fire resistance, to a dowel whose use involves all of the above mentioned criteria (i.e. fire resistance, aggressive environment, dynamic loadings ...). It is entirely the choice of the manufacturer applying for an ETA as to which properties will be assessed and declared in the ETA (including the choice of classes or categories for each property). The choice will depend on the intended use of the dowel and the manufacturer's intended market.

¹ See EN ISO 12944-2:1998, Table 1.

A dowel may include reinforcing bars or steel plates or bars added at the time of fabrication (fixed and welded elements are to be assembled in factory only), which serve to improve the transmission of the shear forces that the dowel is required to carry. In such cases, the ETA shall take account of this in the levels of resistance to be considered. Based on their current use, dowels are separated in this ETA Guideline into 4 families, according to whether they have single or multiple dowel bars and whether they allow axial movement only or axial movement and transverse horizontal movement. The families are as follows:

Table 1 – Types of family of product

Family type A1	Single dowel allowing axial movement only
Family type A2	Single dowel allowing axial and transverse horizontal movement
Family type B1	Multiple dowels allowing axial movement only
Family type B2	Multiple dowels allowing axial and transverse horizontal movement

1.3 Assumed working life of the construction product

The provisions and the verification and assessment methods included or referred to in this ETAG have been written based upon the assumed working life of the dowel connector for an intended use not less than the working life of the works where installed, provided that the dowel is subject to appropriate installation, use and maintenance (see 4.4). These provisions are based upon the current state of the art and the available knowledge and experience.

In any case, because it is not simple to remove and replace dowels, the assumed working life shall not be less than 50 years.

"Assumed working life" means that, when an assessment following the ETAG provisions is made, and when this working life has elapsed, the real working life may be, in normal use conditions, considerably longer without major degradation affecting the Essential Requirements².

The indications given as to the working life of the construction product cannot be interpreted as a guarantee given by the product manufacturer or his representative or the Approval Body issuing the ETA, but are regarded only as a means for choosing the appropriate products in relation to the expected economically reasonable working life of the works (see 5.2.2 of Interpretative Documents).

1.4 Terminology

1.4.1 Common terms relating to the Construction Products Directive

For an extended meaning of the following four common terms, see EOTA document "Common terms used in Guidelines for European technical approval" published on the EOTA website.

- "Product family", see Table 1 for families of dowels defined by the type of transmissible forces and number of rods of the dowel connector.
- "Use category", see Table 3.
- "Stability category", see Table 4.
- "Performance class", see Table 5 for classes of corrosion resistance of steel grades as defined by the material number.

² The real working life of a product incorporated in a specific works depends on the environmental conditions to which that works is subject and the particular conditions of the design, execution, use and maintenance of that works may be outside this ETAG. Therefore, it cannot be excluded that in these cases the real working life of the product may also be shorter than the assumed working life.

1.4.2 Specific terms used in this ETAG

Type of dowel

For one type of dowels the shape (cross section) of the pin, number of pins (multiple dowels) and the type of family stay the same throughout the different sizes of the dowel.

Series of dowels

A series of dowels includes all sizes of the dowel bar with the same number of pins, the same type of family and the same principle shape of fixed reinforcement.

Dowel bar

Steel rod or tube or hollow cross section bar serving to transmit shear forces between connected elements.

Sleeve

Hollow element made of steel or synthetic material housing the dowel bar on the side of the joint allowing movement.

Fixed reinforcement

Reinforcing bars added to the dowel connector at the time of its fabrication in the factory and mechanically connected to it (for example, by welding).

Design reinforcement

Reinforcing bars placed in the elements to be connected at the time of dowel installation.

Slab edge reinforcement

Reinforced concrete strengthening element running along the edge of a slab and serving to distribute the local stresses from the dowels to the slab.

Concrete and steel

f_c = concrete compression strength measured on cylinders as defined in EN 206-1

$f_{c,cube}$ = concrete compression strength measured on cubes as defined in EN 206-1

$f_{c,test}$ = compression strength of concrete at the time of testing

f_{cm} = mean concrete compression strength

f_{ck} = nominal characteristic concrete compression strength (based on cylinder), defined in EN 206-1

$f_{ck,cube}$ = nominal characteristic concrete compression strength (based on cubes) as defined in EN 206-1

$f_{y,p,test}$ = steel tensile yield strength of the dowel as measured according to EN 6892-1

$f_{u,p,k}$ = characteristic resistance of the steel of the dowel as measured according to EN 6892-1

$f_{y,r,test}$ = elastic limit of the reinforcing steel in the concrete elements as measured according to EN 6892-1

$f_{u,r,k}$ = characteristic resistance of the reinforcing steel in the concrete elements as measured according to EN 6892-1

1.5 Procedure in the case of a significant deviation from the ETAG

The provisions of this ETAG apply to the preparation and issue of European Technical Approvals in accordance with Article 9.1 of the CPD and section 3.1 of the Common Procedural Rules.

Where appropriate, in cases in which a certain provision of this ETAG is not or not fully applicable or a particular aspect of a product and/or the intended use to be assessed is not or not sufficiently covered by the methods and criteria of the ETAG, the procedure of Article 9.2 of the CPD and section 3.2 of the Common Procedural Rules may apply with regard to the deviation or aspect concerned.

2 Assessment of fitness for use

2.1 Meaning of "fitness for use"

"Fitness for (the intended) use" of a construction product means that the product has such characteristics that the **works** in which it is to be incorporated **can**, if properly designed and built,

1. **satisfy** the Essential Requirements when and where such works are subject to regulations containing such requirements (CPD Article 2.1) and
2. **be fit** for their intended use, account being taken of economy, **and** in this connection **satisfy** the Essential Requirements for an economically reasonable working life, if normally maintained (see CPD Annex I, sentences 1 and 2).

2.2 Elements of the assessment of fitness for use

The assessment of the fitness of a construction product for its intended use includes:

- identification of the characteristics of the product which are relevant to its fitness for use (in the following referred to as "regulatory characteristics");
- establishment of methods for the verification and assessment of the regulatory product characteristics and the expression of the respective product performances;
- identification of such regulatory characteristics to which the option "No Performance Determined" applies for the reason that in one or more Member States they are not relevant for the fulfilment of the requirements applicable to the works;
- identification of such regulatory characteristics for which limit values (threshold values) have to be respected for technical reasons.

2.3 Relationship of requirements to the product characteristics and methods of verification and assessment

The product characteristics, methods of verification and assessment criteria which are relevant for the fitness of the dowel for structural joints for the intended use referred to in 1.2 are given in Table 2.

In order to facilitate the expression of different performances of the product with regard to combinations of product characteristics referred to in Table 2, distinction is made between the following use categories:

Use category E1: transmission of shear forces under internal exposure conditions (environmental category C1), without any other requirement.

Use category E2: transmission of shear forces under normal external exposure conditions (environmental category C2), without any other requirement.

Use category E3: transmission of shear forces under aggressive external exposure conditions (environmental category C3), without any other requirement.

Use category E4: same criteria as category E1, E2 or E3 with, in addition, a requirement that the connected elements have to provide a specified level of fire resistance.

Use category E5: as category E1, E2 or E3 with, in addition, the application of dynamic or repeated loading to the connected elements.

Use category E6: use in earthquake regions, in addition to any previous category E1 to E5.

Table 2 – Product characteristics and methods of verification and assessment

Nr	Product characteristic	Option "No Performance Determined"	Method of verification and assessment	Expression of product performance
(1)	(2)	(3)	(4)	(5)
Essential Requirement 1: Mechanical resistance and stability				
1	Ultimate limit deformation	No	2.4.1.2	Values of: shear force, crack width, vertical deformation
2	Transmissible shear force	No		
3	Serviceability Limit State	No		
4	Tolerances	No	2.4.1.3	Value (dimension, %)
Essential Requirement 2: Safety in case of fire				
5	Reaction to fire	Yes	2.4.2.1	Euroclasses (EN 13501-1)
6	Resistance to fire	Yes	2.4.2.2	R value
Essential Requirement 3: Hygiene, health and environment				
7	Content and/or release of dangerous substances	Yes	2.4.3.1	(*)
Essential Requirement 4: Safety in use				
8	Nature of surfaces	Yes	2.4.4	Unevenness of both side of the joint 5mm
Essential Requirement 5: Protection against noise				
	<i>Not relevant</i>	-		
Essential Requirement 6: Energy economy and heat retention				
	<i>Not relevant</i>	-		
General aspects relating to fitness for use (i.e. durability)				
	Corrosion resistance	No		Classes of steel 'normal' steel (EN 10025) steel with enhanced corrosion resistance
(*)NPD option regarding ER3: For the meaning of the "NPD" option regarding ER3, see EOTA TR 034 "General Checklist for ETAGs/CUAPs/ETAs – Content and/or release of dangerous substances in products/kits"				

This classification is summarised in Table 3:

Table 3 – Use categories

Use category	Internal environment	Normal environment	Aggressive environment	Fire resistance	Dynamic or repeated loading	Earthquake regions
E1	yes	no	no	no	no	no
E2	yes	yes	no	no	no	no
E3	yes	yes	yes	no	no	no
E4	yes	yes / no	yes / no	yes	no	no
E5	yes	yes / no	yes / no	yes	yes*	no
E6	yes	yes / no	yes / no	yes	yes*	yes*

* E5 or E6 not part of ETAG 030 Part 1, to be dealt with in further parts of ETAG for dowel connector

In combination with these use categories, two stability categories are considered, depending on the gap between the dowel and its sleeve (see Table 4).

Table 4 – Stability categories

Stability category	Dowels
S1	Simple component
S2	Building stability component

Table 5 explains the use categories given in 2.3:

Table 5 – Environmental reference classification

Environmental reference classification	Internal environment	Normal environment	Aggressive environment	Highly aggressive environment
C1		x	x	x
C2			x	x
C3				x
C4				

* For definition of C1 to C4, see EN ISO 12944-2:1998, Table 1

Table 6 gives a list of steel that may be used without a need for corrosion testing. Other steel may be used if, through testing, they are shown to have equivalent corrosion resistance to the steels listed.

Table 6 – Stainless Steel grades with material numbers for use as minimum references in environmental categories for the dowel bar and all parts of the dowel with less than 3 cms concrete cover

Use category ^{*)}	Internal environment	Normal environment	Aggressive environment	Highly aggressive environment
C1	1.4003 Galvanised steel	x	x	x
C2		1.4571	x	x
C3			1.4462	x
C4			1.4362	Not covered by ETAG 030 Parts 1-2-3
*) For definition of C1 to C4, see EN ISO 12944-2:1998, Table 1				

Dowel bars (male part) may be made of stainless steel or galvanized steel.

Dowel sleeves (female part) may be made of stainless steel, galvanized steel or synthetic material.

Where two different steel grades are used for the dowel bar and the sleeve, compatibility of the steels shall be checked and electrical potential proved to be negligible in order to prevent galvanic corrosion phenomenon to set up.

2.4 Product characteristics which are relevant for the fitness for use

2.4.1 Essential Requirement 1: Mechanical resistance and stability

2.4.1.1 Methods of verification

2.4.1.1.1 General

All values given for material strength of:

- steel are in accordance with EN 10025 and EN 6892-1,
- concrete are in accordance with EN 206-1.

At any step of the assessment, the special properties of the stainless steel such as lower Young modulus and hence lower stiffness shall be taken into account.

The verification of the characteristics of the products shall be determined using either the method given in 2.4.1.1.2 (qualification class 1) or the method given in 2.4.1.1.3 (qualification class 2).

Testing arrangement

The tests are to be performed on dowels cast in slab panels of thickness indicated by the ETA applicant. Tests shall be performed for each type³ of dowel connector. For the tests, the slab thicknesses for which the dowel connector is claimed to be suited are defined by the ETA applicant.

The parameters to be taken into account for the qualification of the behaviour are as follows:

- the type of dowel connector (single or multiple, solid or hollow, dimensions, steel elastic limit, etc.),
- the maximum width of the joint crossed by the dowel,
- the test value of the compression strength of the concrete,
- the slab thickness which shall not be less than 15 cms,
- the type of local concrete reinforcement around the dowel connector area.

^[3] "Type" means that shape (cross section), number of pins (for multiple dowels) and proportions stay the same throughout the different sizes of the type.

The tests are performed by placing the dowel connectors in shear. The test panels shall consist of one dowel connector (by opposite to a group of dowel connectors) linking two reinforced concrete slab panels. The overall dimensions of the test panels shall be as follows:

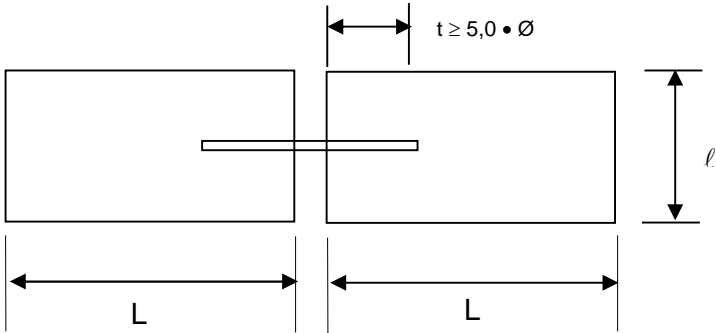

$L \geq 4 t \geq 26 \varnothing$, where \varnothing is the diameter (or the transverse dimension) of the dowel in the direction of shear force
 $l \geq 70$ cms (or width of the predicted cone)

Figure 1 – Principle scheme of the test setting; elevation view of the test panels

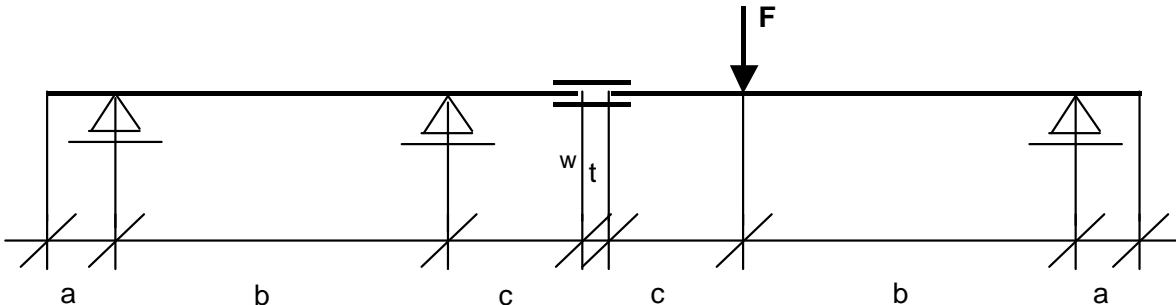

$c \geq 35$ cms (or width of the predicted cone)

Figure 2 – Principle scheme of the test setting; side view of the tests panels

The slab reinforcement shall consist of an edge strengthened beam comprising longitudinal and transverse reinforcement. It is specified by the ETA applicant.

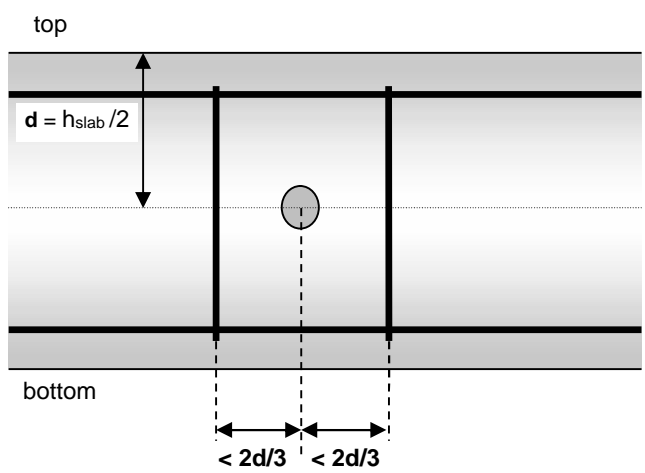

Figure 3 – View of slab reinforcements framing the dowel axis

Ten load cycles between the estimated working load (60 % of the characteristic ultimate limit load considering the actual material properties) and 10 % of the working load shall be performed. The loading rate shall not exceed 10 % of the working load per minute. After the last descending branch has carefully been carried out, one reloading to failure has to be performed.

Measuring equipment

The measurements recorded during the test at each increment of load are as follows:

- vertical deflection of the slabs on either side of the joint,
- force sensor reactions,
- possible settlement of the fixed support,
- strain at the reinforcement stirrups next to the dowel connector, if the influence of the reinforcement is to be evaluated⁴,
- the load at which the first crack appears on the top face of the loaded panel, and the growing of the crack. This is obtained by placing a displacement sensor on the upper edge of the panel above the dowel connector. Whenever critical cracks appear on the edge of the slab, the width, length and the place of the cracks have to be documented.

Figure 4 below specifies the position of displacement gauges.

Gauge s_0 is a witness gauge (blank or neutral),

Gauge s_1 is meant to measure the influence of reinforcement.

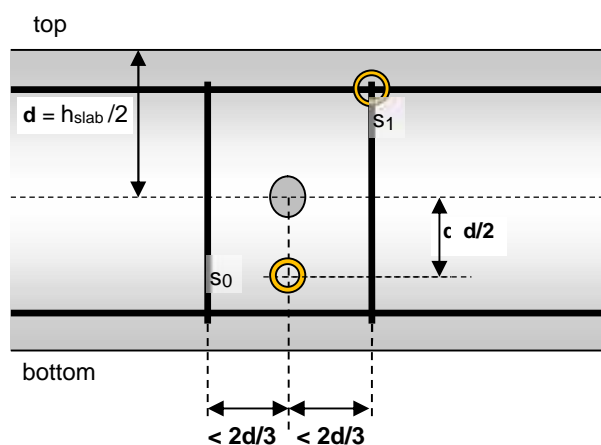

Figure 4 – Position of sensors with respect to slab reinforcements

Material properties

Concrete specimen

The concrete specimens shall be in accordance with EN 206-1 and have to meet the following requirements:

- cement type shall be CEM I 32.5 R or CEM I 42.5 R (according to EN 197-1),
- the water-cement ratio shall not exceed 0,75. The cement content shall be at least 240 kg/m³,
- concrete admixtures, which may affect the concrete properties (like fly ash, silica powders, limestone powder), shall not be added.

⁴ For manufacturers who do not wish to make use of calculation methods (Method 2) but work with fixed reinforcement settings, strain gauges on the stirrups are not necessary.

Evaluation of the material properties

The following material properties have to be determined in the approval tests:

- concrete compression strength,
- concrete tensile strength in bending,
- stress-strain curve of the materials used for the dowel connector, i.e. materials strain at yielding and failure,
- yield strength and tensile strength of the reinforcement.

The concrete strength class in the approval test has to meet the requirements of the concrete strength class published in the ETA with a tolerance of ± 5 N/mm² and has to be constant (same batch).

Test report

The test report shall present all the measurement records at each increment of load for each test performed, up to failure of the test panel.

2.4.1.1.2 Qualification class 1 (Method 1)

Tests

The assessment tests performed on the dowel connectors serve:

- to confirm the load-carrying capacity of the dowel connectors at failure,
- to check the applied load-deformation behaviour,
- to identify the onset of cracking of the concrete elements connected by the dowel connectors,
- to identify the sensitivity of the dowel connector (i.e. the system in use) to variations of the placing of the reinforcement bars that are added on site.

Number of tests

For a given dowel connector (one type and one size), the parameters which may be varied at the request of the applicant are as follows:

- the width of the joint crossed by the dowel,
- the test value of the compression strength of the concrete,
- the thickness of the slab.

For each dowel connector of a type and size, the ETA applicant shall specify:

- the maximum and the minimum values of the width of the joint crossed by the dowel (a_{max} and a_{min}),
- the maximum and the minimum values of the concrete strength that will be used ($f_{ck max}$ and $f_{ck min}$),
- the maximum and the minimum thickness of slab (h_{max} and h_{min}); h_{min} cannot be less than 15 cm,
- the maximum and the minimum local reinforcement area ($A_{l max}$ and $A_{l min}$).

The number of configurations tested for each type and size of dowel connector is defined as follows.

Five (5) specimens shall be tested (3 where the range of intended use is limited).

For $A_{l max}$:

For $f_{ck max}$:

5 tests for h_{min} and a_{max}

5 tests for h_{min} and a_{min}

For $f_{ck \min}$:

5 tests for h_{\min} and a_{\max}

5 tests for h_{\min} and a_{\min}

For $A_{l \min}$:

For $f_{ck \max}$:

5 tests for h_{\min} and a_{\min}

That means that for each given dowel connector (shape, size), 25 tests shall be performed (15 where the range of intended use is limited).

Dowel connectors with perpendicular horizontal movement to the dowel axis allowed

For this type of dowel connectors, the following tests shall be performed in succession (*a* then *b*, then *c*):

- a* One or more different configurations have to be performed depending on the intended use. For each test configuration, a minimum of 5 specimens shall be tested as defined in 2.4.1.1.1. Where the range of intended use is limited, this may be reduced to 3. These tests yield the value of the failure load.
- b* A minimum of 5 specimens of dowel connectors (only 3 specimens where the range of intended use is limited) are subjected to side movements for 1 000 cycles, with 60 % of the minimal failure load above measured. A value of the displacement equal to 80 % of the total movement is allowed.
- c* Finally, these dowel connectors are tested in the same manner as in 2.4.1.1.1 up to failure load. They shall reach 100 % of the resistance according to *a*, otherwise the resistance has to be reduced by the factor $V_{Ru,m,a}/V_{Ru,m,b}$.

2.4.1.1.3 Qualification class 2 (Method 2)

Tests

The aim of this method is to replace some of the tests on dowel connectors of intermediate size, by giving a calculated approximation of the load-bearing capacity, using interpolation between the largest and the smallest dowel connector sizes.

Number of tests

For each type of dowel, 3 tests of the smallest, intermediate and largest size have to be performed according to 2.4.1.1.1. These tests shall be designed in order to create an edge failure.

Dowel connectors with perpendicular horizontal movement to the dowel axis allowed

Additional to the tests in shear (see 2.4.1.1.1), the horizontal movement of these dowels have to be tested. Therefore 3 tests of the smallest, intermediate and largest size have to be performed with side movements for 1 000 cycles, with 60 % of the minimal failure load above measured. A value of the displacement equal to 80 % of the total movement is allowed. Finally, these dowel connectors are tested in the same manner as in 2.4.1.1.2, up to failure load. They shall reach 100 % of the calculated resistance.

2.4.1.2 Method of assessing and judging

2.4.1.2.1 General

Design

The assessment of the dowel connector shall be made assuming that the design method given in Annex A is used.

The assessment of the characteristics of the products shall be made using either the method given in 2.4.1.2.2 (qualification class 1) or the method given in 2.4.1.2.3 (qualification class 2).

Dimensions and tolerances

Information (e.g. drawings with tables) shall be given for the dimensions and tolerance of the product to be identified.

For families A1 and B1, with sleeves made of steel, when the gap between the dowel pin(s) and the sleeve(s) does not exceed 1 mm, they can be used as buildings stability components.

Products with synthetic sleeves cannot be used as buildings stability components.

2.4.1.2.2 Qualification class 1 (Method 1)

Evaluation of test results

The characteristic resistance of the dowel connector corresponds to the 10 % fractile with a level of confidence of 75 % according to EN 1990.

For each tested configuration (defined type of dowel, size, local reinforcement A_l , concrete strength f_{ck} , slab thickness h , joint width a) the characteristic resistance F_k is calculated by the following equation:

$$F_k = F_m - k \times \sigma_F$$

with F_m the sample mean value (i.e. load at failure / at first crack) and σ_F the sample standard deviation.

Factor k depends on the size of the sample (n), the confidence level and the fractile (ISO 2394:1998). For a 90 % fractile and a confidence level of 75 %, a few values of k are given in Table 7.

Table 7 – Values of k (n), for 90 % fractile (one sided), confidence 75 %

n	3	4	5	6	8	10	20
k	2,50	2,13	1,96	1,86	1,74	1,67	1,53

The characteristic resistance $V_{Rk,u}$ and $V_{Rk,s}$ are assessed from the tests, respectively from the loads to failure and from the loads when a crack first appear ($V_{Rk,a}$ cannot be determined from the tests).

Design values of resistance

For each tested configuration, the design values can be calculated from the characteristic resistances. Design values between the maximum and minimum joint can be interpolated.

$$V_{Rd,u} = V_{Rk,u} / \gamma_{R,u} \quad \text{with } \gamma_{R,u} = 1,5$$

$$V_{Rd,s} = V_{Rk,s} / \gamma_{R,s} \quad \text{with } \gamma_{R,s} = 1,35$$

$$V_{Rd,a} = V_{Rd,u}$$

NOTE: Three failure modes can occur: 'Steel failure', 'Through-the-thickness failure' and 'Concrete Edge failure'. The ultimate load should be representative of one of those. However, due to more or less ductile behavior of the steel pin

(and somewhat of the reinforced concrete) and the allowed axial displacement of the dowel, failure mode can be mixed. Most times, with a good design, the dowel pin(s) will bend and concrete slab will eventually fail.

According to national regulations or in order to account for specific failure modes and uncertainty on the materials, the safety factors $\chi_{R,u}$ may be adjusted in the range 1,15 (for steel failure and ductile behavior) to 2,5 (in case of brittle failure) if comprehensive documentation is provided.

This design value of resistance can be used for all intended configurations when the slab thickness, the local reinforcement and concrete strength are higher than in the corresponding tests.

The tolerance in positioning the dowel and the associated reinforcement has to be considered with joint width in addition. It is taken equal to 10 mm except where each reinforcing bar is individually, rigidly secured in place, guaranteeing a maximum concrete cover of 20 mm, in which case it can be taken equal to 5 mm.

2.4.1.2.3 Qualification class 2 (Method 2)

Evaluation of test results

The dimension H_{spec} , l_c and b_{cone} (see Figure 5) has to be determined by tests and depends on how many stirrups are activated (hence the necessity to document this with strain gauges).

As the first step, the model ($V_{u,cal}$) with appropriate H_{spec} , l_c and b_{cone} shall predict the failure loads ($V_{u,test}$) with an accuracy of at least 10 % below the actual failure load ($V_{u,cal} = 0,9 \cdot V_{u,test}$) for the smallest and the largest dowel connector covered by the ETA to be issued.

The second step is to predict the failure load for an intermediate size of dowel connector, whose load bearing capacity is close to the arithmetic mean load bearing capacity of the smallest and the largest dowel connector, with a maximum deviation of 10 % below the actual load bearing capacity.

If this assumption holds true, the shear load bearing capacity of other intermediate sizes can be calculated using H_{spec} , l_c and b_{cone} as specified. These values shall also be stated in the ETA.

If the second step condition is not met successfully, the values of H_{spec} , l_c and b_{cone} shall be modified on and on until the condition is satisfied with the same accuracy as required before (10 % max).

The procedure is to be carried out until either H_{spec} , l_c or b_{cone} are sufficiently well known (or all dowel connector sizes shall be tested).

$$V_{u,cal} = V_{u,cal,1} + V_{u,cal,2} \leq A_s \cdot f_{yk}$$

$V_{u,cal,1}$ force transmitted into the concrete by the stirrups arranged to the left and right of the dowel connector, only taking into account the part which can be allocated to the hook (bent pin at the top and bottom faces of the slab)

$$V_{u,cal,1} = X_1 \cdot \sum_i A_s \cdot f_{yk} \cdot (f_{c,test} / 30)^{1/2}$$

X_1 specific product factor

factor taking account the distance $l_{c,i}$ of the considered stirrup to the dowel
 $= 1 - 0,2 \cdot (l_{c,i} / c_1)$

A_s Cross section area of the bar of the stirrup

f_{yk} characteristic yield strength of the stirrup

$f_{c,test}$ concrete compressive strength of the test slab

$V_{u,cal,2}$ bonding action along the straight part of the stirrup between top and bottom faces of the slab.

$$V_{u,cal,2} = \pi \cdot d_s \cdot \sum l'_{1,i} \cdot 2,25 \cdot 0,7 \cdot 0,3 \cdot f_{c,test}^{2/3}$$

d_s diameter of the stirrup

$l'_{1,i}$ effective anchorage length of the considered stirrup:

$$l'_{1,i} = l_{1,i} - l_{1,min}$$

$$l_{1,min} = (0,5 \cdot d_b + d_s)$$

- d_b mandrel diameter of the stirrup
 $l_{1,i}$ anchorage length of the considered stirrup

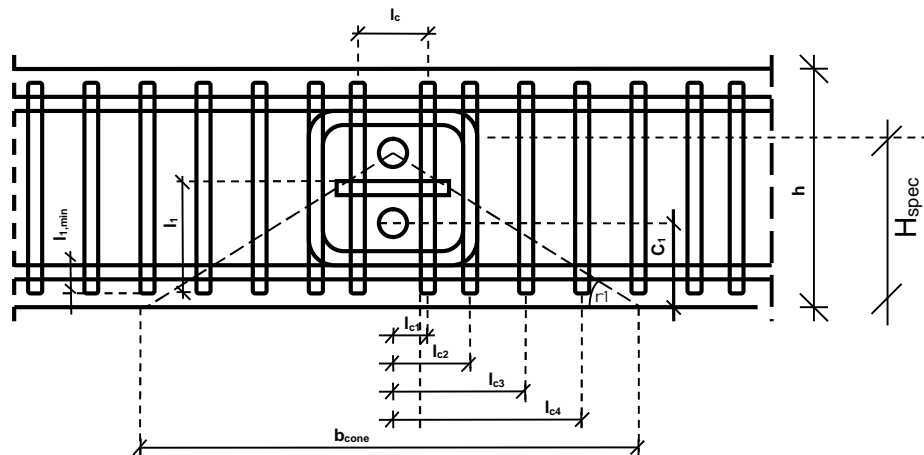

- l_c virtual diameter of the dowel connector, representing the column diameter in the punching failure. The exact relation between the actual measures of the dowel connector and the virtual diameter may need fitting on a case by case basis, though being constant through each ETA
 $l_c = 2 \cdot l_{c1}$
- H_{spec} height of the concrete cone measured in the test
- b_{cone} width of the concrete cone
- $\tan \alpha = H_{spec} / b_{cone}$

Figure 5 – Reinforcements of the slab around dowels; length and dimensions

Design values of resistance

The verification against the ultimate limit state shall be performed as follows.

Three failure modes can occur:

- 1) $V_{Rd,s}$ = 'Steel failure', failure of the steel element,
- 2) $V_{Rd,ct}$ = 'Through-the-thickness failure', failure of the entire slab around the dowel connector, comparable to punching failure at the edge of the slab,
- 3) $V_{Rd,ce}$ = 'Concrete Edge failure', failure of the slab at the lower edge.

All three ultimate limit states are investigated, the lowest value of these three presenting the ultimate shear resistance of the dowel connector.

Addendum 1)

The resistance of the steel element (dowel connector including the attached steel elements) is assessed according to EC 3.

The fixing point of a dowel bar without attached steel elements is $0,5 \varnothing$ behind the concrete surface. This distance can be reduced to zero with attached steel elements if they are designed accordingly. In order to consider the additional tension caused by the axial movement of the dowel, the steel resistance of the dowel has to be reduced by 0,9. The steel resistance of dowel family type A2 and B2 has to be reduced by 0,81.

Addendum 2)

The “Through-thickness” resistance of the slab results from the following equation:

$$V_{Rd,ct} = 0,14 \cdot \kappa \cdot (100 \cdot \rho_l \cdot f_{ck})^{1/3} \cdot u \cdot d_m / \beta$$

$$\kappa = 1 + (200 / d_m)^{1/2}$$

d_m mean effective cross section of the slab

ρ_l mean reinforcement ratio in directions parallel and perpendicular to the slab edge:

$$\rho_l = \sqrt{\rho_{lx} \cdot \rho_{ly}} \leq \begin{cases} 0,5 \cdot f_{cd} / f_{yd} \\ 0,02 \end{cases}$$

f_{cd} design concrete compressive strength

f_{yd} design reinforcement yield strength

f_{ck} characteristic concrete compressive strength

β load factor, $\beta = 1,4$ (dowel connector installed at the edge of the slab)

$\beta = 1,5$ (dowel connector installed at the corner of the slab)

u basic control perimeter according to Figure 6

$$u = 2 \cdot c + l_c + \pi \cdot d_m \cdot 1,5$$

c concrete cover

l_c virtual diameter of the dowel connector, representing the column diameter in the punching failure. The exact relation between the actual measures of the dowel connector and the virtual diameter may need fitting on a case by case basis, though being constant through each ETA.

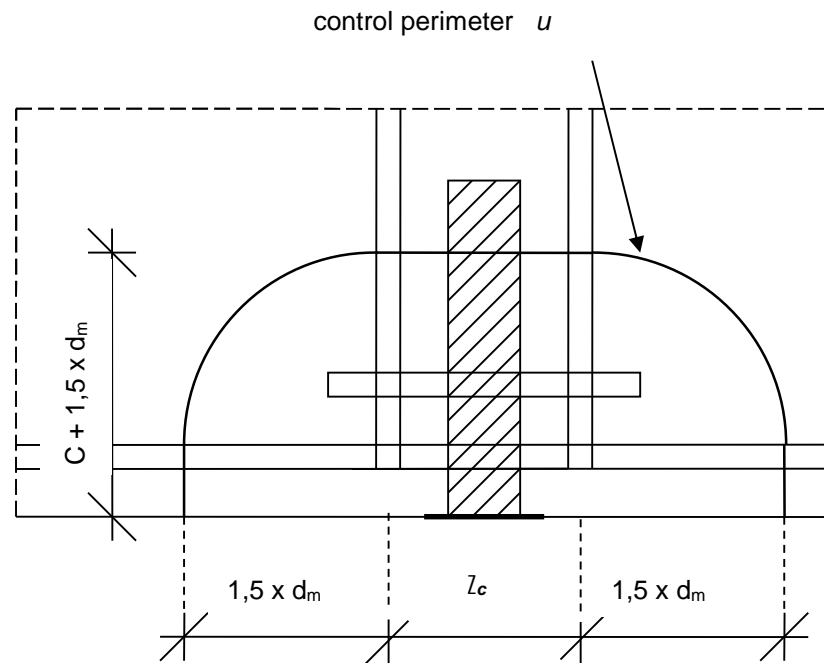

Figure 6 – Basic control perimeter

Addendum 3)

The load bearing capacity $V_{Rd,ce}$ results from the following equation:

$$V_{Rd,ce} = V_{Rd,1} + V_{Rd,2} \leq A_s \cdot f_{yd}$$

$$V_{Rd,1} = X_1 \cdot X_2 \cdot \sum_i A_{s,i} \cdot f_{yk,i} \cdot (f_{ck}/30)^{1/2} / \gamma_c$$

$$V_{Rd,2} = \pi \cdot d_s \cdot \sum_i l'_{1,i} \cdot f_{bd,i}$$

X_2 value of the evaluated 5%-fractile with a confidence level of 75 % of $V_{u,test} / V_{u,cal}$ (has to be $\geq 1,5$).

2.4.2 Essential Requirement 2: Safety in Case of Fire

2.4.2.1 Method of verification

2.4.2.1.1 Reaction to fire

Where the sleeve is made of synthetic material, it shall be tested as material in order to be classified according to EN 13501-1. Only one size of the dowel type need fire testing. For sleeves made of steel, the product is classified as A1 without testing.

2.4.2.1.2 Resistance to fire

The part of the works or assembled system in which the dowel connector is intended to be incorporated, installed or applied shall be tested, using the test method relevant for the corresponding fire resistance class, in order to be classified according to EN 13501-2. These tests have to be performed with the maximum defined joint width.

If the steel grade is S360⁵ or lower, the fire resistance is evaluated from the characteristic value of the load (as derived in 2.4.1.1.2) by applying the method of verification and calculation that can be taken from EN 1992-1-2 and EN 1993-1-2, using the national safety parameters. For higher strength steel, a separate assessment of the performance has to be carried out as there is no experience available with such dowel systems.

2.4.2.2 Method of assessing and judging

2.4.2.2.1 Reaction to fire

The product shall be classified according to EN 13501-1.

2.4.2.2.2 Resistance to fire

The part of the works or assembled system in which the dowel connector is intended to be incorporated, installed or applied shall be classified according to EN 13501-2. The result is declared using the same classification parameters as for the assembled system (as R value for the dowel connector alone).

⁵ According to EN 10025-1 Hot rolled products of structural steels – Part 1: General technical delivery conditions.

2.4.3. Essential Requirement 3: Hygiene, Health and Environment

2.4.3.1 Content and/or release of dangerous substances

The applicant shall either:

- submit the chemical constitution and composition of the materials and components of the product to the Approval Body which will observe strict rules of confidentiality
- or
- submit a written declaration to the Approval Body stating whether or not and in which concentration the materials and components of the product contain substances which have to be classified as dangerous according to Directive 67/548/EEC and Regulation (EC) No 1272/2008 and listed in the "Indicative list on dangerous substances" of the EGDS, taking into account the installation conditions of the construction product and the release scenarios resulting from there.

The content of cadmium contained either in the steel used or in the zinc coatings shall be declared by the applicant.

The use of recycled materials shall always be indicated, because this could lead to the implementation of further assessment and verification methods.

The information concerning the presence of dangerous substances listed in Council Directive 67/548/EEC and Regulation (EC) No 1272/2008 regulated at European level and listed in the "Indicative list on dangerous substances" of the EGDS and/or of other dangerous substances, shall be circulated as part of the evaluation report by the issuing Approval Body to the other Approval Bodies, under strict conditions of confidentiality.

2.4.3.2 Method of verification

Materials and components of the product listed in the EOTA TR 034 "General Checklist for ETAGs/CUAPs/ETAs – Content and/or release of dangerous substances in products/kits", which have to be considered will be verified by the given methods, taking into account the installation conditions of the assembled system/component of the assembled system and the release scenarios resulting from there. Regulations related to placing the product on the market may also need to be taken into account.

Regarding the release scenarios referred to in the EOTA TR 034, the following use categories have to be considered:

Category IA1: Product with direct contact to indoor air.

Category IA2: Product with no direct contact to (e.g. covered products) but possible impact on indoor air.

Category IA3: Product with no contact to and no impact on indoor air.

Category S/W2: Product with no direct contact to but possible impact on soil, ground and surface water.

Category S/W3: Product with no contact to and no impact on soil, ground and surface water.

Categories IA1 and S/W1 are applicable for products which are in contact with indoor air, soil or water in a way that dangerous substances could be released directly out of the product.

Category IA2 is applicable for products which are covered with other products but nevertheless could release dangerous substances to indoor air (e.g. products covered with porous/unsealed coverings incapable of avoiding migration).

Category S/W2 is applicable for products which can be leached by rain and could release dangerous substances which can have impact on soil and water.

Categories IA3 and S/W3 are applicable for products which are completely covered with tight products capable of avoiding any kind of migration of dangerous substances to indoor air, soil or water.

Content restrictions have to be considered in all cases.

2.4.3.3 Method of assessing and judging

Materials and components of the product listed in the EOTA TR 034: "General Checklist for ETAGs/CUAPs/ETAs – Content and/or release of dangerous substances in products/kits" (or equivalent EOTA document), and the related dangerous substances which have to be considered, will be assessed by the given methods taking into account the installation conditions of the construction product and the release scenarios resulting from there.

The content of cadmium contained either in the steel used or in the zinc coatings shall be declared by the applicant.

NOTE: For dangerous substances falling under the scope of the CPD for which:

- no assessment and verification methods are given (or cannot be found in TR 034),
- or
- "no performance determined" is declared,
- or
- the chosen verification and assessment method does not comply with the regulatory requirement of a particular Member State,

there might be the necessity for an additional assessment.

2.4.4 Essential Requirement 4: Safety in use

Surface unevenness of connected works: the dowel connectors shall be designed, fabricated and installed in such a way that all parts of the connected elements of the works are even, so as to prevent the risk of injury through tripping and falling.

When connecting floor slabs, the surface unevenness between the two sides of the joint has to be less than 5 mm. With time, concrete creep being uncertain to assess, the manufacturer shall specify in the Product Handbook that unevenness should be maintained below 5 mm (through finishing for example).

2.4.5 Essential Requirement 5: Protection against noise

Not relevant.

2.4.6 Essential Requirement 6: Energy Economy and Heat Retention

Not relevant.

3 Evaluation and attestation of conformity and CE marking

3.1 System of attestation of conformity

According to the decision **98/214/CEE** of the European Commission⁶ the system of attestation of conformity given in Table 8 applies.

Table 8 – System of attestation of conformity applicable to dowels for structural joints

Products	Intended use(s)	Level(s) or class(es)	Attestation of conformity system
Dowels for structural joints	For uses subject to structural performance regulations	-	2+

In addition, according to the decision **98/214/CEE** of the European Commission⁶ the attestation of conformity systems given in Table 9 apply to dowels for structural joints with regard to reaction to fire.

Table 9 – Choice of the system of attestation of conformity applicable to dowels with respect to reaction to fire

Products	Intended use(s)	Level(s) or class(es) (<i>reaction to fire</i>)	Attestation of conformity systems
Dowels for structural joints	For uses subject to regulations on reaction to fire	A1*, A2*, B*, C*	1
		A1**, A2**, B**, C**, D, E	3
		(A1 to E)***, F	4
System 1: See Directive 89/106/EEC Annex III.2.(i), without audit-testing of samples System 3: See Directive 89/106/EEC Annex III.2.(ii), Second possibility System 4: See Directive 89/106/EEC Annex III.2.(ii), Third possibility * Products/materials for which a clearly identifiable stage in the production process results in an improvement of the reaction to fire classification (e.g. an addition of fire retardants or a limiting of organic material) ** Products/materials not covered by footnote (*) *** Products/materials that do not require to be tested for reaction to fire (eg. Products/materials of class A1 according to Commission Decision 96/603/EC, as amended)			

The systems of attestation of conformity referred to above are therefore defined as follows:

- for entirely metallic products the system of attestation of conformity is **2+ (decision 98/214/CEE)**,
- for products including non metallic components for which the characteristic reaction to fire needs to be tested, the system of attestation is either **1** or **2+** depending on the reaction to fire class and, if **2+**, reaction to fire is tested by a Notified Test Laboratory.

⁶ Official Journal of the European Communities L 080 of 18/03/98.

System 1 : Certification of the conformity of the product by a notified body on the basis of:

(a) Tasks for the manufacturer:

- (1) factory production control,
- (2) further testing of samples taken at the factory by the manufacturer in accordance with a prescribed test plan.

(b) Tasks for the notified body:

- (3) initial type-testing of the product,
- (4) initial inspection of factory and of factory production control,
- (5) continuous surveillance, assessment and approval of factory production control.

System 2+: Declaration of conformity of the product by the manufacturer on the basis of:

(a) Tasks for the manufacturer:

- (1) initial type-testing of the product,
- (2) factory production control,
- (3) testing of samples taken at the factory in accordance with a prescribed test plan.

(b) Tasks for the notified body:

- (4) certification of factory production control on the basis of:
 - initial inspection of factory and of factory production control,
 - continuous surveillance, assessment and approval of factory production control.

3.2 Tasks and responsibilities of the manufacturer and notified bodies

3.2.1 Tasks for the manufacturer

Initial type-testing of the product (System 2): Initial type testing testing will be available as part of the required assessment of products for issuing European Technical Approvals unless there are changes in the production line or plant.

The manufacturer has to provide details on the following points:

- specification and verification of raw materials and constituents,
- the methods and the extend of his permanent internal control of production,
- the test methods to be carried out during manufacturing,
- the type and minimum frequency of controls,
- verification and controls and their frequency to be carried out on the finished product.

The manufacturer has to adhere to the control plan of the ETA, containing at least the following points:

- check of material used for the dowels, all required data shall be certified by a 3.1 test certificate according to EN 10204 on the yield and tensile strength and the R_e/R_t ratio,
- all welding has been performed according to the ETA control plan,
- essential measurements of the product comply with ETA requirements.

In cases of modification of the product or the method of production, the manufacturer shall notify the Approval Body and, where this may affect the declared properties, initial type-testing shall be performed (in accordance with Chapter 2 of this ETAG). Only those characteristics which may be changed by the modification need to be subjected to this initial type-testing.

3.2.2 Tasks for notified body

Certification of factory production control on the basis of:

- initial type-testing of the product (System 1); initial type testing testing will be available as part of the required assessment of products for issuing European Technical Approvals unless there are changes in the production line or plant.
- Initial inspection of factory and of factory production control (System 1, System 2+).
- Continuous surveillance, assessment and approval of factory production control (System 1, System 2+).

This includes all measures in the control plan for the ETA issued on the basis of this ETAG, i.e.:

- Check of materials used for the dowels, including chemical properties as well as the mechanical properties of yield and tensile strength and the R_e/R_t ratio according to EN 6892-1.
- Method and quality standard of welding and qualification of the employed staff that have been performed according to the ETA control plan.
- Essential measurements of the product complying with ETA requirements.

3.3 CE marking and accompanying information

According to Council Directive 93/68/EEC⁷ the CE marking consists of the letters "CE" in the form laid down in the Directive, followed by the identification number of the notified certification body, where applicable. For products subject to Council Directive 89/106/EEC to which system 1 or 2+ of attestation of conformity applies, the identification number of the notified certification body shall be given.

The accompanying information to the CE marking shall contain the minimum thickness of the slab where the dowel may be installed, the environmental class for which the steel of the dowel is fit for use and the qualification class.

Installation instructions, specifying the relevant parameters (category of use, environmental category, maximum distance between the joined concrete elements, characteristic value of the transmissible shear force, if possible, the safety values to be applied to obtain the design value of the transmissible shear force) shall also be given.

⁷ Official Journal of the European Communities L 220 of 30.8.1993.

4 Assumptions under which the fitness for the intended use is assessed

In all following assessment procedures, it will be assumed that the dowels are installed in concrete members designed and executed to a standard similar or in accordance to EC 2. All concrete properties will be related to EN 206-1, and will take into account either of the methods presented in Annex A.

4.1 Manufacture of the product

It is assumed that the product is manufactured in accordance with the ETA issued on the grounds of this ETAG. All welding occurring during the manufacture process of the dowel connector has to be performed in the factory; no part of the process may be performed on site.

4.2 Packaging, transport, storage of the product

It is assumed that the product is transported in such a way that damage to the weld seams cannot occur, also the smoothness of the surfaces has to be maintained.

4.3 Installation of the product in the works

It is assumed that the concrete members joined by the dowel connector are designed according to a standard or code similar to EC 2, that all forces transmitted by the dowel connector and distributed by the reinforcement described in the ETA are properly transmitted to the supports or to other structural members designed to resist this action-effect, using either European or national standards, but always applying good engineering practice. A Product Handbook (or leaflet, provided by the manufacturer) consisting of installation instructions shall always be on hand when installing dowel connectors on site.

4.4 Use, maintenance, repair

It is assumed that the dowels will stay functional throughout their entire assumed working life span. If, by unforeseen actions or environmental conditions, repair is necessary, the national or relevant Guidelines or standards for the repair and strengthening of concrete structures shall be observed.

5 Identification of the construction product

5.1 Means of identification

The product which is the subject of the Technical Approval shall be identified by:

- testing of product characteristics as laid down in Table 10,
- fingerprinting,
- formulation.

These three parameters shall be obtained from the manufacturer of the material used.

If the dowel connector contains synthetic parts, an appropriate method shall be determined by the Approval Body to identify the synthetic components.

For the dowels, the parameters are:

- Manufacturing process parameters.
- Calculations, detailing, drawings.

Table 10 – Product characteristics, methods of verification and criteria used for checking the product identity

Number	Product characteristic*	Verification method: 5.2.1.1	Criteria for product identity: 5.2.1.2
(1)	(2)	(3)	(4)
	Mechanical strength	EN 10025, EN 6892-1	Yield stress
	Chemical properties		

* These characteristics are also relevant to the fitness for use (see 2.3, Table 2).

5.2 Product characteristics which are relevant for identification checking

5.2.1 Identification characteristic of the product (for steel used)

5.2.1.1 Method of verification

The method of verification of the steel used to manufacture the dowel connector shall be described in each ETA according to the specifics of the ETA contents. However, for all steel products, samples may be taken and tested in accordance with EN 6892-1 and EN 10025 for mechanical strength, and also for the chemical composition of the steel in order to ascertain that either they are of the same grade as the manufacturer's technical specifications or that they exhibit not lesser performance (e.g. see Table 6).

5.2.1.2 Criteria for product identity

The criteria for product identity shall be described in each ETA according to the specific ETA content as needed by the Approval Body and shall always form part of the ETA.

6 Format of ETAs issued on the basis of the ETAG

European Technical Approvals issued on the basis of this ETAG shall be in accordance with the ETA format given in the Annex C to the ETAG.

7 Reference documents

This part of ETA-Guideline 030 incorporates, by dated or undated reference, provisions from other publications. These normative references are cited at the appropriate places in the text and the publications are listed below. For dated references subsequent amendments to, or revisions of these publications, apply to this ETA-Guideline only when incorporated in it by amendment or revision. For undated references the latest dated revision of the publication referred to applies.

- EN 1990, *Eurocode – Basis of structural design.*
- EN 1991-1-1, *Eurocode 1 – Actions on structures – Part 1-1: General actions – Densities, self weight, imposed loads for buildings.*
- EN 1991-1-2, *Eurocode 1 – Actions on structures – Part 1-2: General actions – Actions on structures exposed to fire.*
- EN 1992-1-1, *Eurocode 2 – Design of concrete structures – Part 1-1: General rules and rules for buildings.*
- EN 1992-1-2, *Eurocode 2 – Design of concrete structures – Part 1-2: General rules – Structural fire design.*
- EN 1993-1-1, *Eurocode 3 – Design of steel structures – Part 1-1: General rules and rules for buildings.*
- EN 1993-1-2, *Eurocode 3 – Design of steel structures – Part 1-2: General rules – Structural fire design.*
- EN 13501-1, *Fire classification of construction products and building elements – Part 1: Classification using data from reaction to fire.*
- EN 13501-2, *Fire classification of construction products and building elements – Part 2: Classification using data from fire resistance tests, excluding ventilation services.*
- EN ISO 12944-2:1998, *Paints and varnishes – Corrosion protection of steel structures by protective paint systems – Part 2: Classification of environments.*
- EN 206-1, *Concrete – Part 1: Specification, performance, production and conformity.*
- EN 197-1, *Cement – Part 1: Composition, specifications and conformity criteria for common cements.*
- EN 10025-1, *Hot rolled products of structural steels – Part 1: General technical delivery conditions.*
- EN 10025-5, *Hot rolled products of structural steels – Part 5: Technical delivery conditions for structural steels with improved atmospheric corrosion resistance.*
- EN 6892-1, *Metallic materials – Tensile testing – Part 1: Method of test at room temperature.*
- EN 10204, *Metallic products – Types of inspection documents.*
- EN 1090-1, -2, -3, *Execution of steel structures and aluminium structures.*
- EOTA TR034, *General ER 3 Checklist for ETAGs/CUAPs/ETAs – Content and/or release of dangerous substances in products/kits.*
- ISO 2394:1998, *General principles on reliability for structures.*

Annex A

DESIGN OF THE WORKS

In the absence of any codified requirements (e.g. Eurocodes), the following provisions are recommended.

General

The designer shall take account of the following specific requirements:

- The maximum spacing between adjacent dowel connectors resisting the same relative movement is set at 8 times the thickness of the concrete elements (≤ 15 cms) connected by the dowel connectors. For the purposes of this requirement, the thickness shall be measured according to the direction of action of the shear force transmitted by the dowel connector.
- The concrete reinforcing bars (rebars) intended to transmit the localised shear force from the dowel to the whole surrounding concrete bulk shall be arranged and formed in such a way that the incidental shear force is resisted by the whole concrete element. In the case of slabs, this requirement is met by placing hangers, shear links or U-bars positioned vertically on either side of the dowel, in such a way that the horizontal sides of the link (or the legs of the U-bar) are situated close to the upper and lower faces of the slab. They shall be formed in such a way that the cover reinforcement (relative to the upper surface, the underside and the vertical edges of the slab) never exceeds 3 cms (tolerance included).
- No minimum spacing between adjacent dowels resisting the same relative movement is specified in theory. However, in order to take into account the eventuality for the networks of cracks originating from two adjacent dowels to intersect, a penalty shall be applied in the case of slabs, where the spacing of the dowels is less than 2,5 times the thickness of the concrete element connected by them. This penalty shall consist of one of the following:
 - reducing the allowable shear forces by a coefficient equal to $0,4 \cdot e/h$.
 - increasing the cross section of the reinforcing steel by a coefficient equal to $(2-0,4 \cdot e/h)^3$, with "e" the spacing of two adjacent dowels and "h" the thickness of the concrete element.
- The minimum embedment depth to ensure that the dowel functions properly shall be 6,5 times its diameter Φ . This minimum anchorage length shall be checked in the least favourable case of the joint opening. This minimum anchorage may, however, be reduced to 5Φ on condition that the value of the resisting shear forces is reduced by a coefficient equal to the square of the ratio of the anchored length to $6,5\Phi$ or additional U-bars or steel constructions are necessary. An anchorage length of less than 5Φ shall be considered as having no effective shear resistance.
- The dowels shall not be incorporated in thin slabs on account of their mode of operation. A table in the ETA shall indicate the conditions to be met for the allowable shear forces to apply. In any cases, the thickness of the slabs shall not be less than 15 cms.
- The slab thickness H to be used in the calculations shall be taken as twice the distance to the nearest concrete face (top or underside of the slab). In the case of a floor slab with concrete permanent shuttering (pre-slab), the designer's attention is drawn to the need, in the detailing, to allow for both the specific reinforcement required for the dowel bars and the connecting reinforcement between the shuttering and the cast in-situ concrete, since the permanent shuttering is hanging from the cast in-situ concrete slab.
- The design joint width "a" in millimetres to be used in the calculations is defined as follows:

$$a = a_0 + \Delta a_s + \Delta a_d + \Delta a_f$$

where

- a_0 is the construction width of the joint.
- Δa_s is the increase in the width of the joint under the effect of the combination of actions considered in the verification.

- Δa_d is the increase in the width of the joint under the effect of delayed deformations due to shrinkage and temperature. Where the effects of these actions are accounted for by a fixed (default) value, Δa_d is taken equal to 5 mm. In other cases, Δa_d shall be taken as zero and the corresponding deformations included in Δa_s .
- Δa_f is intended to account for the uncertainties related to the sharing of forces between the dowels in the case of stiff elements. It is taken as zero where at least one of the two elements connected by the dowels is a floor slab. It is taken as half the diameter (or the height) of the dowel section in other cases.
- Edge beams shall be formed (within the bulk of the slab or otherwise) along the length of the joint in which the dowels are placed. These beams shall be designed assuming as follows:
 - the beam forms a linear support for the adjacent slab,
 - the dowels form individual supports for the beam.
- Vehicle wheel loads shall be increased by a fixed coefficient of 1,33 in absence of national regulation.
- The cross section of the uniformly distributed additional vertical edge reinforcing bars shall not be less than 3,33 cms² for B 500 steel per linear metre of the edge of the slab. Use of reinforcing bars with elastic limit in the range 400 MPa to 600 MPa is permitted; then, the minimum surface of the cross sections shall be calculated in the exact proportion to B 500 steel. The use of the published values (resisting shear forces) assumes that such reinforcement (or its equivalent) is provided along the edge of the slab in addition to the reinforcement associated with each dowel. The type of uniformly distributed additional vertical edge reinforcement to be used shall be tested and specified in the ETA.
- The resisting shear forces (V_{Ru} , V_{Rs} and V_{Ra}) shall be reduced by the following coefficient, defined according to the number of dowels simultaneously concerned by the relative movement of the two structural elements that they connect:
 - 0,75 for a single dowel.
 - 0,90 for two dowels.
 - 1,00 for three dowels and over.
- The dowels shall be designed by checking each of the following inequalities corresponding to the combination of basic, service and accidental loads:
 - $V_{Sd,u} \leq V_{Rd,u}$
 - $V_{Sd,s} \leq V_{Rd,s}$
 - $V_{Sd,a} \leq V_{Rd,a}$

These inequalities compare the acting shear forces $V_{Sd,u}$, $V_{Sd,s}$ and $V_{Sd,a}$ against the resisting shear forces V_{Rdu} , V_{Rds} and V_{Rda} . The first one has to be checked in any cases. The second one only requires to be checked in cases where cracking is considered detrimental (e.g. floor finishes). The third one only applies in accidental situations.

- The acting forces are nationally defined.
- In beam ends containing superimposed dowels, the loads are assumed to be transmitted to the dowels by a strut acting at 45° to each dowel. Vertical hangers and horizontal reinforcing bars should thus be provided to resist the corresponding loads.

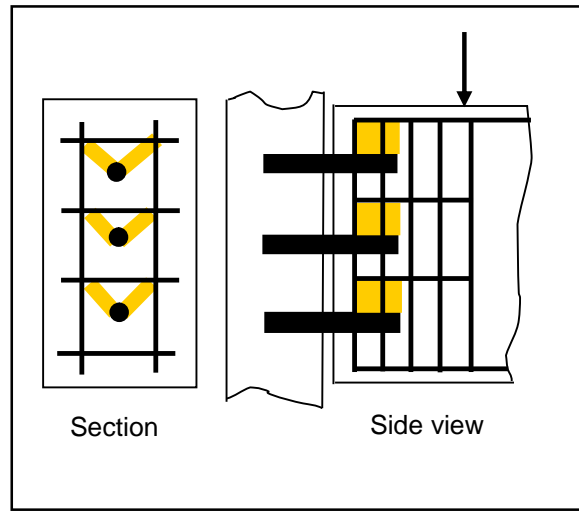

Figure A.1 – Schematic positions of reinforcements near and around superimposed dowels

Additional requirements for qualification class 1 (method 1)

- All design values of shear load resistance of every type of dowel shall be given by the ETA. This design value of resistance can be used for all intended configurations when the slab thickness, the local reinforcement and concrete strength are higher than in the corresponding tests.
- The reinforcement shall have an effective overall cross section A for every dowel determined as follows:

$A = \text{Max} (A_u; A_s; A_a)$ with the following details:

$$A_u = X_u V_u / f_e$$

$A_s = X_s V_s / f_e$ in cases where cracking is considered detrimental and zero in other cases.

$A_a = X_a V_a / f_e$ in accidental situations and zero in other cases.

The values of X_u , X_s and X_a according to the required class are given in Table A.1, in the absence of national regulation.

Table A.1 – PSF according to cross-section class

Class	γ_u	γ_s	γ_a
1	2,68	5,10	2,55
2	1,5	2,50	-
3	1,15	1,75	-

NOTE: Definition of cross-section classes (EN 1993-1-1)

Class 1 Plastic cross-sections: those which can develop a plastic hinge with sufficient rotation capacity to allow redistribution of bending moments in the structure.

Class 2 Compact cross-sections: those which can develop the plastic moment resistance of the section but where local buckling prevents rotation at constant moment in the structure.

Class 3 Semi-compact cross-sections: those in which the stress in the extreme fibres should be limited to yield because local buckling would prevent development of the plastic moment resistance of the section.

Annex B CONTROL PLAN

Each ETA shall specify the mandatory factory production control on the basis of a control plan.

Tests to be performed by the manufacturer as part of FPC shall include:

- Check of material used for the dowels, including chemical properties as well as the mechanical properties of yield and tensile strength and the Re /Rt ratio according to EN 6892-1.
- Method and quality standard of welding and what qualification of the employed personnel has been performed according to the ETA control plan.
- Essential measurements of the product complying with ETA requirements.
- Verification of the material properties of the stainless steel by the notified body, including the chemical properties and verification of the material number.

The control plan is made in view of the requirements for the attestation of conformity for the product covered by the ETA.

Annex C

ETA MODEL FOR DOWELS FOR STRUCTURAL JOINTS

I LEGAL BASES AND GENERAL CONDITIONS

- 1 This European Technical Approval is issued by [Approval Body] in accordance with:
 - Council Directive 89/106/EEC of 21 December 1988 on the approximation of laws, regulations and administrative provisions of Member States relating to construction products⁸, modified by Council Directive 93/68/EEC⁹ and Regulation (EC) N° 1882/2003 of the European Parliament and of the Council¹⁰;
 - [indicate respective national law transposing the CPD; only if the national law of the Member State of the issuing Approval Body so requires];
 - Common Procedural Rules for Requesting, Preparing and the Granting of European Technical Approvals set out in the Annex to Commission Decision 94/23/EC¹¹;
 - Guideline for European Technical Approval of “Dowels for Structural Joints” ETAG 030, edition 2013, Part 1 “General” [and other relevant Parts].
- 2 [Approval Body] is authorized to check whether the provisions of this European Technical Approval are met. Checking may take place in the manufacturing plant(s). Nevertheless, the responsibility for the conformity of the products to the European Technical Approval and for their fitness for the intended use remains with the holder of the European Technical Approval.
- 3 This European Technical Approval is not to be transferred to manufacturers or agents of manufacturers other than those indicated on page 1, or manufacturing plants other than those [indicated on page 1/ laid down in the context] of this European Technical Approval.
- 4 This European Technical Approval may be withdrawn by [Approval Body], in particular pursuant to information from the Commission according to Article 5(1) of Council Directive 89/106/EEC.
- 5 Reproduction of this European Technical Approval including transmission by electronic means shall be in full. However, partial reproduction can be made with the written consent of [Approval Body]. In this case partial reproduction has to be designated as such. Texts and drawings of advertising brochures shall not contradict or misuse the European Technical Approval.
- 6 The European Technical Approval is issued by the Approval Body in its official language(s). This (These) version(s) corresponds (correspond) fully to the version circulated within EOTA. Translations into other languages have to be designated as such.

8 Official Journal of the European Communities L 40, 11.2.1989, p. 12.

9 Official Journal of the European Communities L 220, 30.8.1993, p. 1.

10 Official Journal of the European Union L 284, 31.10.2003, p. 25.

11 Official Journal of the European Communities L 17, 20.1.1994, p. 34.

II SPECIFIC CONDITIONS OF THE EUROPEAN TECHNICAL APPROVAL

1 Definition of product and intended use

1.1 Definition of product

Description of the dowel, summary of main dimensions and material properties, indication of family type according to Table 1 of ETAG 030 [...].

For the installed product see figure given in Annex [...].

1.2 Intended use

The product is intended for uses where requirements concerning “mechanical resistance and stability”, “safety in case of fire”, “hygiene, health and environment” as well as “safety in use”, in the sense of the Essential Requirements ER1, ER2, ER3 and ER4 of the Directive 89/106/EEC shall be satisfied and where failure of the product may cause risk to human life and health and/or lead to considerable economic consequences.

The dowel is to be used under static or quasi static actions in reinforced normal concrete of the minimum strength class C20/25 according to EN 206-1 to transmit shear loads from one part of the structure to an adjacent part. The construction product may be anchored in cracked and non-cracked concrete. The dowel allows in-plane movement in one or two directions between the connected parts and may be stressed by shear loads. The concrete elements to be connected shall be at least 15 cms thick.

The steel may only be used in concrete subject to conditions specified in this ETA and only in environments that do not contain highly¹² aggressive agents.

This dowel may be used in the following use categories [...] and the following stability categories [...] (differentiate if not applicable for all types).

1.3 Assumed working life of the product

The provisions made in this European Technical Approval are based on an assumed intended working life of the product for an intended use not less than the working life of the works where installed, provided that the dowel is subject to appropriate installation, use and maintenance. In any case, because it is not simple to remove and replace dowels, the assumed working life must not be less than 50 years.

The indications given on the working life cannot be interpreted as a guarantee given by the producer, but are to be regarded only as a means for choosing the right products in relation to the expected economically reasonable working life of the works.

2 Characteristics of the product and method of verification

2.1 Characteristics of the product

2.1.1 General

The following information should be given in each ETA:

- ER 1 (in accordance with Table 2 of the ETAG 030 Part 1)
Ultimate limit deformation, transmissible shear force, tolerances.
- ER 2 (in accordance with Table 2 of the ETAG 030 Part 1)
Reaction to fire, Resistance to fire

Regarding the requirements concerning safety in case of fire (ER 2) for a dowel made of steel only, it is assumed that the construction product meets the requirements of class A1 in relation to reaction to fire in accordance with the stipulations of the Commission decision 96/603/EC, amended by 2000/605/EC.

- ER 3 (in accordance with Table 2 of the ETAG 030 Part 1)
Dangerous substances (in accordance with 2.4.3.1)
- ER 4 (in accordance with Table 2 of the ETAG 030 Part 1)
Evenness of surfaces of the jointed concrete members for safety in use (to avoid stumbling)
Handling, transportation, mounting and fixing shall be specified in a manual by the manufacturer.
- Durability
Choice of material according to corrosion resistance in compliance with Table 6 of the ETAG 030 Part 1.

2.1.2 Dowel rod

Base materials, including their parameters such as Young's modulus, yield strength, tensile strength, dimensions, tolerances, and preferably drawings.

2.1.3 Steel plate and or steel rebars

Base materials, including their parameters such as Young's modulus, yield strength, tensile strength, dimensions, tolerances, preferably drawings.

2.1.4 Finished product

The maximum difference between the dimensions of the dowel rod and the sleeve has to be specified in the ETA.

The reinforcement to be installed to grant load transfer shall comply with the type of reinforcement (steel strength, diameters and spacing) derived from the tests (Method 1) or the calculations (Method 2) and shall always be given in the ETA (preferably taking reference to drawings).

2.1.5 Welded joint

Shall be performed in the manufacturing plant only.

This is to ensure that the safety provisions of EN 1090 are satisfied.

2.1.6 Dimensions and tolerances

- (1) Dimensions and tolerances of the steel rod.
- (2) Dimensions and tolerances of the steel elements to be cast in concrete.
- (3) Dimensions and tolerances of the steel or synthetic sleeve.

2.1.7 Marking

The dowel connector is identified by the diameter of shaft, the nominal length and the yield strength of the material used for the dowel.

The identifying mark of the producer and the material according to Annex [...] shall be marked on the product.

2.2 Methods of verification

2.2.1 General

The assessment of the fitness of the product for the intended use with regard to the requirements of "mechanical resistance and stability", "safety in case of fire", "hygiene, health and environment" as well as "safety in use" in the sense of the Essential Requirements 1, 2, 3 and 4 was carried out on the basis of the "Guideline for European Technical Approval of Dowels for Structural Joints" (ETAG 030) and the tests performed.

¹² See EN ISO 12944-2:1998, Table 1.

2.2.2 ER 1

2.2.2.1 Tests carried out

2.2.2.2 Calculated verifications

2.2.2.3 Basic values for the resistance under shear load to determine the ultimate limit deformation, the transmissible shear force and the serviceability limit state

- (1) **Steel failure**
- (2) **Punching failure (“Through-the-Thickness” failure)**
- (3) **Concrete Edge failure**

2.2.3 ER 2

If the fire resistance is relevant then the fire resistance of the concrete member in which the construction product is anchored has to be tested according to test method provided and classified (according to EN 13501-2).

The dowel connectors shall be tested, using the test method(s) relevant for the corresponding reaction to fire class, in order to be classified according to EN 13501-1. For dowels and sleeves made of steel only, the product is classified as A1 without testing.

2.2.4 ER 3

A declaration of the manufacturer, based on a certificate 3.1 of EN 10204 of the steel maker shall be available, about the presence, or not, of cadmium (either in the steel or in the zinc coating) and any other dangerous substance, e.g. radioactive compound.

Include the following text in section “Emission of dangerous substances or radiation”:

According to [the chemical constitution and composition of the materials and components of the product / the written declaration on dangerous substances (whichever applies)] submitted by the ETA-holder to the Approval Body:

(...)¹³

In addition to the specific clauses relating to dangerous substances contained in this European Technical Approval, there may be other requirements applicable to the products falling within its scope (e.g. transposed European legislation and national laws, regulations and administrative provisions). In order to meet the provisions of the EU Construction Products Directive, these requirements need also to be complied with, when and where they apply.

Note: For dangerous substances falling under the scope of the CPD for which

- no assessment and verification methods are given (or cannot be found in TR 034),
- or
- “no performance determined” is declared,
- or
- the chosen verification and assessment method does not comply with the regulatory requirement of a particular Member State,

there might be the necessity for an additional assessment.

2.2.5 ER 4

¹³ For the expression of the assessment results on dangerous substances in the ETA, the Approval Bodies will follow the provisions given in Annex 1 to the Addendum to EOTA GD 001, March 2012, “Criteria for the ETA content of dangerous substances information”.

Mounting and fixing instructions shall be supplied, based on the experience of the manufacturer and the Approval Body.

3 Attestation of conformity of the product and CE marking

3.1 System of attestation of conformity

According to the decision **98/214/CEE** of the European Commission¹⁴ the system of attestation of conformity given in Table C.1 applies.

Table C.1 – System of attestation of conformity applicable to dowels for structural joints

Products	Intended use(s)	Level(s) or class(es)	Attestation of conformity system
Dowels for structural joints	For uses subject to structural performance regulations	-	2+

In addition, according to the decision **98/214/CEE** of the European Commission¹⁴ the system(s) of attestation of conformity given in Table C.2 applies to dowels for structural joints with regard to reaction to fire.

Table C.2 – Choice of the system of attestation of conformity applicable to dowels with respect to reaction to fire

Products	Intended use(s)	Level(s) or class(es) (<i>reaction to fire</i>)	Attestation of conformity systems
Dowels for structural joints	For uses subject to regulations on reaction to fire	A1*, A2*, B*, C*	1
		A1**, A2**, B**, C**, D, E	3
		(A1 to E)***, F	4
System 1: See Directive 89/106/EEC Annex III.2.(i), without audit-testing of samples			
System 3: See Directive 89/106/EEC Annex III.2.(ii), Second possibility			
System 4: See Directive 89/106/EEC Annex III.2.(ii), Third possibility			
* Products/materials for which a clearly identifiable stage in the production process results in an improvement of the reaction to fire classification (e.g. an addition of fire retardants or a limiting of organic material)			
** Products/materials not covered by footnote (*)			
*** Products/materials that do not require to be tested for reaction to fire (e.g. products/materials of class A1 according to Commission Decision 96/603/EC, as amended)			

The system(s) of attestation of conformity referred to above are therefore defined as follows:

- For entirely metallic products, the system of attestation of conformity is **2+ (decision 98/214/CEE)**.
- For products including non metallic components for which the characteristic reaction to fire needs to be tested, the system of attestation is either **1** or **2+** depending on the reaction to fire class and, if **2+**, reaction to fire is tested by a Notified Test Laboratory.

¹⁴ Official Journal of the European Communities L 080 of 18/03/98.

[System 1] or [System 2+]

System 1 : Certification of the conformity of the product by a notified body on the basis of:

(a) Tasks for the manufacturer:

- (1) factory production control,
- (2) further testing of samples taken at the factory by the manufacturer in accordance with a prescribed test plan.

(b) Tasks for the notified body:

- (3) initial type-testing of the product,
- (4) initial inspection of factory and of factory production control,
- (5) continuous surveillance, assessment and approval of factory production control.

System 2+: Declaration of conformity of the product by the manufacturer on the basis of:

(a) Tasks for the manufacturer:

- (1) initial type-testing of the product,
- (2) factory production control,
- (3) testing of samples taken at the factory in accordance with a prescribed test plan.

(b) Tasks for the notified body:

- (4) certification of factory production control on the basis of:
 - initial inspection of factory and of factory production control,
 - continuous surveillance, assessment and approval of factory production control.

3.2 Responsibility

3.2.1 Tasks for the manufacturer; factory production control

(Whenever System 2 applies) [...]

[...]

For initial type-testing, the results of the tests performed as part of the assessment for the European Technical Approval shall be used unless there are changes in the production line or plant. The Approval Body will have assessed the results of these tests in accordance with chapter 2 of ETAG 030, as part of the ETA issuing procedure.

...].

The manufacturer has a factory production control system in the plant and exercises permanent internal control of production. All the elements, requirements and provisions adopted by the manufacturer are documented in a systematic manner in the form of written policies and procedures. The factory production control system ensures that the product is in conformity with this European Technical Approval.

The manufacturer shall only use raw materials supplied with the relevant technical information as laid down in the prescribed test plan¹⁵. The incoming raw materials shall be subject to controls and/or tests by the manufacturer before acceptance. The check shall include control of relevant technical information (comparison with nominal values) presented by the manufacturer of the raw materials by inspecting the dimensions and determination of the material properties.

¹⁵ The prescribed test plan has been deposited at the Approval Body and is handed over only to the approved body involved in the conformity attestation procedure.

The material properties of the raw materials of dowels are to be determined.

The dimensions of the manufactured components of the product are to be checked.

The required verifications and requirements on welding according to the EN 1090 series shall be fulfilled.

The frequency of controls and tests conducted during production is laid down in the prescribed test plan¹⁵ and takes into account the manufacturing process of the product.

The results of the factory production control are recorded and evaluated. The records include at least the following information:

- type of control or testing,
- date of manufacture of the product and date of testing of the product or of the basic materials and components,
- results of control and testing and, if appropriate, comparison with the requirements,
- signature of person responsible for the factory production control.

The records shall be presented to the inspection body involved in the continuous surveillance. On request they shall be presented to Approval Body.

Details of extent, nature and frequency of testing and controls to be performed within the factory production control shall correspond to the prescribed test plan¹⁵, which is part of the technical documentation of this European Technical Approval.

3.2.2 Tasks for the notified bodies

3.2.2.1 Initial inspection of factory and of factory production control

The approved body shall ascertain that, in accordance with the prescribed test plan¹⁵, the factory, in particular the staff and equipment, and the factory production control are suitable to ensure a continuous and orderly manufacturing of the product with the specifications mentioned in this ETA as well as in the Annexes to the European Technical Approval, including the system of providing information about dangerous substances according to 2.2.4 of this ETA.

3.2.2.2 Continuous surveillance

The approved body shall visit the factory at least once a year for surveillance. It has to be verified that the system of factory production control and the specified manufacturing process are maintained while taking account of the prescribed test plan¹⁵.

Continuous surveillance and assessment of factory production control have to be performed according to the prescribed test plan¹⁵.

The results of FPC certification and continuous surveillance shall be made available on demand by the certification body or inspection body, respectively, to the Approval Body.

In cases where the provisions of the European Technical Approval and the prescribed test plan¹⁵ are no longer fulfilled, the conformity certificate shall be withdrawn.

(Whenever System 1 applies) [...]

[...]

3.2.2.3 Initial type-testing

For initial type-testing, the results of the tests performed as part of the assessment for the European Technical Approval shall be used unless there are changes in the production line or plant. In such cases, the necessary initial type-testing has to be agreed between the Approval Body and the notified body. The Approval Body will have assessed the results of these tests in accordance with chapter 2 of ETAG 030, as part of the ETA issuing procedure.

[...]

3.3 CE marking

The CE marking shall be affixed to each packaging or on the accompanying documents of the product. In addition to the initials "CE" the following information shall be given:

- identification number of the certification body,
- name or identifying mark of producer and manufacturing plant,
- the last two digits of the year in which the CE marking was affixed,
- number of the EC certificate of conformity,
- number of the European Technical Approval,
- name of the product,
- diameter of the dowel rod,
- yield strength of the base material,
- type of family of dowel according to Table 1 of this ETAG,
- type of environment of intended use (according to Table 3 and 5 of this ETAG),
- stability category (according to Table 4 of this ETAG),
- qualification class (1 or 2 according to 2.4.1 of this ETAG).

4 Assumptions under which the fitness of the product for the intended use was favourably assessed

4.1 Manufacturing

The product is manufactured in accordance with the provisions of the European Technical Approval using the manufacturing process as identified and agreed in the inspection of the plant by the [Approval Body] and the approved body and laid down in the technical documentation. Changes to the product or production process, which could result in this deposited data/information being incorrect, should be notified to [Approval Body] before the changes are introduced. The [Approval Body] will decide whether or not such changes affect the approval and consequently the validity of the CE marking on the basis of the approval and, if so, whether further assessment or alterations to the approval shall be necessary.

4.2 Packaging, transport, storage of the product

It is assumed that the product is transported in such a way that damage to the weld seams may not occur; the smoothness of the surfaces has also to be maintained.

4.3 Installation

4.3.1 Design

The fitness of the product for the intended use is given under the following conditions:

The design is based on the design method in [*here the relevant design codes or EC 2 with applicable national annexes have to be cited*] under the responsibility of an engineer experienced in concrete building.

Verifiable calculation notes and drawings are prepared taking account of the loads to be transferred. The transfer of the loads to be anchored in the concrete member is verified.

Single dowels or groups of dowels are used.

The position of the product is indicated on the design drawings (e.g. position of the dowels with respect to the reinforcement).

[*Here, detailed guidance according to the properties of the specific dowel described in the ETA shall be given. Stress the importance to place the reinforcement very accurately in the vicinity of the dowel*].

4.3.2 Installation

The fitness of the dowel for the intended use can be assumed, only if the following installation conditions are observed:

- Installation is carried out by suitably experienced personnel and under the supervision of the person responsible for technical matters on site.
- Use of the product only as supplied by the manufacturer without exchanging the components.
- Installation in accordance with the manufacturer's specifications and the design drawings with exact position, dimensions and size as described in this ETA.
- The dowel shall be fixed to the formwork or auxiliary constructions in a way that no movement of the product will occur during placing of reinforcement or during placing and compacting of the concrete.
- The concrete surrounding the reinforcement and under the dowel shall be properly compacted (no cavities).

- Observation of the prescribed values of installations.

Welding-on of the intended and designed steel components to the cast-in construction product may only be performed by companies meeting the corresponding quality requirements for welding according to EN 1090.

4.3.3 Responsibility of the manufacturer

It is the responsibility of the manufacturer to ensure that the information on the specific conditions according to sections 1 and 2 of this ETA including annexes referred to and 4.3.1 and 4.3.2 is given to those who are concerned. This information may be made by reproduction of the respective parts of the European Technical Approval. In addition all installation data shall be shown clearly on the package and/or on an enclosed instruction sheet, preferably using illustration(s).

The minimum data required are:

- dimensions,
- material of the steel plate,
- type of transmissible force,
- details on the installation of procedure, preferably by using illustrations.

All data shall be presented in a clear and explicit form.