

European Organisation for Technical Approvals
Europäische Organisation für Technische Zulassungen
Organisation Européenne pour l'Agrément Technique

red. Anm. Derzeit nicht in deutscher Fassung verfügbar

ETAG n°032

Edition of May 2013

**GUIDELINE FOR EUROPEAN TECHNICAL
APPROVAL
of
EXPANSION JOINTS FOR ROAD BRIDGES**

(Part one : G E N E R A L)

EOTA 2013
Kunstlaan 40 Avenue des Arts
B - 1040 BRUSSELS

Table of Contents

FOREWORD	6
SECTION ONE: INTRODUCTION	10
1. PRELIMINARIES	10
1.1 Legal basis	10
1.2 Status of ETAG.....	10
2. SCOPE	11
2.1 General	11
2.1.1 Detailed scope	11
2.1.2 Parts	11
2.1.2.1 General	11
2.1.2.2 Families of product	12
2.1.3 Relationship with European harmonized standards	12
2.2. USE CATEGORIES AND KITS.....	13
2.2.1 Use categories	13
2.2.2 Kits.....	13
2.3 ASSUMPTIONS	13
2.3.1 Main structure	14
2.3.2 Temperatures.....	14
2.3.3 Installation	14
2.3.4 Working life	14
3. TERMINOLOGY.....	15
3.1 Common terminology and abbreviations	15
3.2 Terminology and abbreviations specific to this ETAG.....	15
3.2.1 Terminology	15
3.2.2 Abbreviations.....	19
SECTION TWO: GUIDANCE FOR THE ASSESSMENT OF THE FITNESS FOR USE	20
GENERAL NOTES	20
4. REQUIREMENTS	22
4.0 Table linking the Essential Requirements to Road Bridge Expansion Joint performance	23
4.1 Kits	23
4.1.1 Mechanical resistance and stability	23
4.1.1.1 General	23
4.1.1.2 Mechanical resistance	24
4.1.1.3 Resistance to fatigue	24
4.1.1.4 Seismic behaviour.....	24
4.1.1.5 Movement capacity.....	27
4.1.1.6 Cleanability.....	27
4.1.1.7 Resistance to wear	27
4.1.1.8 Watertightness	27
4.1.2 Safety in case of fire.....	27
4.1.3 Hygiene, health and environment.....	27
4.1.3.1 Release of dangerous substances	27
4.1.4 Safety in use	28
4.1.4.1 Ability to bridge gaps and levels in the running surface.....	28
4.1.4.2 Skid resistance	30
4.1.4.3 Drainage capacity	30
4.1.5 Protection against noise	30
4.1.6 Energy economy and heat retention	30
4.1.7 Aspects of durability, serviceability and identification of the products	30
4.1.7.1 Aspects of durability.....	30
4.1.7.2 Aspects of serviceability	31
4.1.7.3 Aspects of identification	31
4.2 Components.....	32
5. METHODS OF VERIFICATION.....	33
5.0 General	33
5.1 Kits.....	33
5.1.1 Mechanical resistance and stability	33
5.1.1.1 General	33

5.1.1.2 Mechanical resistance	34
5.1.1.3 Resistance to fatigue	34
5.1.1.4 Seismic behaviour	35
5.1.1.5 Movement capacity	35
5.1.1.6 Cleanability	35
5.1.1.7 Resistance to wear	36
5.1.1.8 Watertightness	36
5.1.2 Safety in case of fire	36
5.1.3 Hygiene, health and environment	36
5.1.3.1 Presence of dangerous substances in the product	36
5.1.3.2 Compliance with the applicable regulations	36
5.1.3.3 Application of the precautionary principle	36
5.1.4 Safety in use	37
5.1.4.1 Ability to bridge gaps and levels in the running surface	37
5.1.4.2 Skid resistance	37
5.1.4.3 Drainage capacity	37
5.1.5 Protection against noise	37
5.1.6 Energy economy and heat retention	37
5.1.7 Aspects of durability, serviceability and identification of the products	37
5.1.7.1 Aspects of durability	37
5.1.7.2 Aspects of serviceability	39
5.1.7.3 Aspects of identification	39
5.2 Components	39
6. ASSESSING AND JUDGING THE FITNESS OF PRODUCTS FOR AN INTENDED USE	40
6.0 <i>Table linking the Essential Requirements to product requirements</i>	40
6.1 <i>Kits</i>	41
6.1.1 Mechanical resistance and stability	41
6.1.1.1 General	41
6.1.1.2 Mechanical resistance	41
6.1.1.3 Resistance to fatigue	41
6.1.1.4 Seismic behaviour	41
6.1.1.5 Movement capacity	41
6.1.1.6 Cleanability	41
6.1.1.7 Resistance to wear	41
6.1.1.8 Watertightness	41
6.1.2 Safety in case of fire	42
6.1.3 Hygiene, health and environment (ER 3)	42
6.1.3.1 Release of dangerous substances	42
6.1.4 Safety in use	42
6.1.4.1 Ability to bridge gaps and levels in the running surface	42
6.1.4.2 Skid resistance	42
6.1.4.3 Drainage capacity	42
6.1.5 Protection against noise	42
6.1.6 Energy economy and heat retention	42
6.1.7 Aspects of durability, serviceability and identification of the products	43
6.1.7.1 Aspects of durability	43
6.1.7.2 Aspects of serviceability	44
6.1.7.3 Aspects of identification	44
6.2 <i>Components</i>	44
7. ASSUMPTIONS AND RECOMMENDATIONS UNDER WHICH THE FITNESS FOR USE OF THE PRODUCTS IS ASSESSED	45
7.0 <i>General</i>	45
7.1 <i>Design of works</i>	45
7.2 <i>Packaging, transport and storage</i>	46
7.2.1 <i>Packaging</i>	46
7.2.2 <i>Transport and storage</i>	46
7.3 <i>Execution of works</i>	46
7.4 <i>Maintenance and repair</i>	47
SECTION THREE: ATTESTATION OF CONFORMITY (AOC)	48
8. ATTESTATION AND EVALUATION OF CONFORMITY	48
8.1 <i>EC decision</i>	48
8.2 <i>Responsibilities</i>	48
8.2.1 <i>Tasks for the manufacturer</i>	48
8.2.1.1 <i>Factory production control (FPC)</i>	48
8.2.1.2 <i>Testing of samples taken at the factory – Prescribed Test Plan</i>	50

8.2.2 Tasks of the Approved Body.....	50
8.2.2.1 General	50
8.2.2.2 Initial Type-Testing	50
8.2.2.3 Assessment of the factory production control system. Initial inspection and continuous surveillance	50
8.2.2.4 Certification	50
8.3 Documentation	51
8.4 CE marking and accompanying information	52
SECTION FOUR: ETA CONTENT	53
9. THE ETA CONTENT	53
9.1 The ETA-content	53
9.1.1 Model ETA	53
9.1.2 Checklist for the Approval Body.....	53
9.2 Additional information.....	56
9.3 Confidential information.....	57
9.4 Installation requirements	57
ANNEXES TO THE ETAG	58
ANNEX A COMMON TERMINOLOGY (DEFINITIONS, CLARIFICATIONS, ABBREVIATIONS) ..	59
ANNEX B ASSUMPTION OF WORKING LIFE OF CONSTRUCTION PRODUCTS (EOTA GUIDANCE DOCUMENT 002).....	59
ANNEX C ASSESSMENT OF THE WORKING LIFE OF PRODUCTS (EOTA GUIDANCE DOCUMENT 003).....	59
ANNEX D THE PROVISION OF DATA FOR ASSESSMENT LEADING TO ETA (EOTA GUIDANCE DOCUMENT 004).....	59
ANNEX E EDITORIAL ASPECTS OF ETAGS (EOTA GUIDANCE DOCUMENT 005).....	59
ANNEX F REFERENCE MATERIAL FOR ETAGS, COMPREHENSION DOCUMENTS FOR ETAGS, UPDATING PROCESS OF ETAGS	59
ANNEX G TRAFFIC LOADS AND COMBINATIONS.....	60
G.1 – GENERAL.....	60
G.2 – STATIC LOAD MODELS.....	62
G.2.1 – Vertical load model.....	62
G.2.1.1 – Tandem arrangements	62
G.2.1.2 – Load Model 1	64
G.2.1.3 – Loads on footways.....	67
G.2.1.4 – Accidental load.....	67
G.2.2 – Horizontal load model.....	68
G.2.2.1 – Braking and acceleration forces	68
G.2.2.2 – Centrifugal forces	69
G.2.2.3 – Accidental loads	69
G.2.2.3.1 – Kerb units not repairable and/or not replaceable	69
G.2.2.3.2 – Kerb units repairable and/or replaceable.....	70
G.3 – FATIGUE LOAD MODELS	70
G.3.1 – General.....	70
G.3.2 – Fatigue load Model 1 (FLM1 _{EJ}).....	71
G.3.3 – Fatigue Load Model 2 (FLM2 _{EJ}).....	72
G.4 – VERIFICATION	72
G.4.1 – General.....	72
G.4.2 – Combinations at the ultimate limit state.....	72
G.4.2.1 – Traffic loads and design situations (combinations)	73
G.4.2.2 – Combinations for accidental situations	75
G.4.2.3 – Combination for seismic design situations	75
G.4.2.4 – Combination for fatigue limit state.....	77
G.4.3 – Combinations at the serviceability limit state	77
G.4.3.1 – Characteristic combination	77
G.4.3.2 – Frequent combination.....	78

<i>List of abbreviations</i>	79
ANNEX H NUMBER OF PRODUCTS TO BE TESTED	81
ANNEX J SEISMIC APPROACH DESIGN PHILOSOPHY FOR RBEJ	83
<i>J.1 – Introduction</i>	83
<i>J.2 – Movement capacity cases</i>	83
<i>J.3 – Bridges with fusible links</i>	84
ANNEX K MOVEMENT CAPACITY TEST METHOD	85
K.1 – OBJECT	85
K.2 – SCOPE	85
K.3 – TERMS AND DEFINITIONS	85
<i>K.3.1 – Movement</i>	85
<i>K.3.2 – Movement capacity</i>	85
<i>K.3.3 – Horizontal displacement</i>	85
<i>K.3.4 – Vertical displacement</i>	85
<i>K.3.5 – Transverse displacement</i>	85
<i>K.3.6 – Gap</i>	86
K.4 – PRINCIPLE	86
K.5 – EQUIPMENT.....	86
K.6 – SAMPLES AND PREPARATION OF TEST SPECIMENS	87
<i>K.6.1 – Dimensions</i>	87
<i>K.6.2 – Control of samples</i>	88
<i>K.6.3 – Installation of samples on the test frame</i>	88
K.7 – PROCEDURE	88
<i>K.7.1 – Testing conditions</i>	88
<i>K.7.2 – Test procedure</i>	88
K.8 – EXPRESSION OF RESULTS	89
K.9 – TEST REPORT	89
ANNEX L WATERTIGHTNESS TEST METHOD	90
L.1 – SCOPE.....	90
L.2 – DEFINITIONS.....	90
L.3 – PRINCIPLE	90
L.4 – SAMPLES AND PREPARATION OF TEST SPECIMENS.....	92
<i>L.4.1 – Dimensions</i>	92
<i>L.4.2 – Control of samples</i>	92
<i>L.4.3 – Installation of samples on the test frame</i>	92
<i>L.4.4 – Test rig</i>	92
L.5 – TEST PROCEDURE.....	92
<i>L.5.1 – Beginning of the test</i>	92
<i>L.5.2 – Test temperature</i>	92
<i>L.5.3 – Execution of the test</i>	92
L.6 – EXPRESSION OF THE RESULTS.....	93
L.7 – TEST REPORT	93

FOREWORD

- Background of the subject

This draft ETA Guideline has been established by WG 01.07/02 “Expansion joints” dealing with expansion joints used on road bridges. The Working Group consisted of members from 8 EU-countries; Austria, Belgium, Czech Republic, Finland, France (convenorship), Germany, Italy, Netherlands and United Kingdom. In addition, Switzerland and Slovenia have been corresponding members together with members appointed by the European Expansion Joint Manufacturers Association.

Since Expansion joints are based on different functioning principles and materials, which might necessitate additional specific verification and /or assessment, they've been divided into the following product families:

Buried expansion joint

Flexible plug expansion joint

Note: Which is a flexible expansion joint in the sense of the mandate.

Nosing expansion joint

Mat expansion joint

Cantilever expansion joint

Supported expansion joint

Modular expansion joint

This ETA Guideline Part 1 – General deals with common aspects and shall be used in conjunction with one of the relevant complementary part for each product (see 2.1.2).

- Reference documents

Reference documents are referred to within the body of the ETAG and are subject to the specific conditions mentioned therein.

The **list of reference documents** (mentioning the year of issue, where relevant) for this ETAG is given below. Additional parts of this ETAG modify this list to be applicable to that Part.

Updating conditions

The edition of a reference document given in this list is that which has been adopted by EOTA for its specific use.

When a new edition becomes available, this supersedes the edition mentioned in the list only when EOTA has verified or re-established (possibly with appropriate linkage) its compatibility with the Guideline.

EOTA Technical Reports go into detail in some aspects and as such are not part of the ETAG but express the common understanding of existing knowledge and experience of the EOTA-bodies at that moment. When knowledge and experience is developing, especially through approval work, these reports can be amended and supplemented.

EOTA Comprehension Documents permanently take on board all useful information on the general understanding of this ETAG as developed when delivering ETAs by consensus among the EOTA members. Readers and users of this ETAG are advised to check the current status of these documents with an EOTA member.

EOTA may need to make alterations/corrections to the ETAG during its life. These changes will be incorporated into the official version on the EOTA website www.eota.be and the actions catalogued and dated in the associated **Progress File**.

Readers and users of this ETAG are advised to check the current status of the content of this document with that on the EOTA website. The front cover will indicate if and when amendment has taken place.

EC/EOTA documents

- [1] CPD: Directive relating to construction products. Council Directive of 21 December 1988 on the approximation of laws, regulations and administrative provisions of the Member States relating to construction products (89/106/EEC) taking account of the modified provisions (93/68/EEC).
- [2] ID No 1 (Mechanical Resistance and Stability): Council Directive 89/106/EEC, Construction Products Interpretative Documents.
- [3] ID No 3 (Hygiene, Health and the Environment): Council Directive 89/106/EEC, Construction Products Interpretative Documents.
- [4] ID No 4 (Safety in use): Council Directive 89/106/EEC, Construction Products Interpretative Documents.
- [5] ID No 5 (Protection against noise): Council Directive 89/106/EEC, Construction Products Interpretative Documents.
- [6] EC Guidance Paper A: The designation of Approved Bodies in the field of the construction products directive, CONSTRUCT 95/149 Rev. 2.
- [7] EC Guidance Paper B: The definition of factory production control in technical specifications for construction products, CONSTRUCT 95/135 Rev 1.
- [8] EC Guidance Paper C: The treatment of kits and systems under the construction products directive, CONSTRUCT 96/175 Rev. 2.
- [9] EC Guidance Paper D: CE-marking under the construction products directive, CONSTRUCT 97/220 Rev. 5.
- [10] EC Guidance Paper E: Levels and classes in the Construction Product Directive, CONSTRUCT 99-337 Rev.1.
- [11] EC Guidance Paper F: Durability and the Construction Products Directive, CONSTRUCT 99/367.
- [12] EC Guidance Paper H: A harmonised approach relating to dangerous substances under the Construction Product Directive, CONSTRUCT 99/363 Rev.1.
- [13] EC Guidance Paper L: Application and use of Eurocodes under the Construction Product Directive, CONSTRUCT 01/483 Rev.1.
- [14] ETA-format: Commission decision of 22nd July 1997 on the general format of European Technical Approvals for construction products, 97/571/EC, O.J. No L 236/7 to 13, 27th August 1997.
- [15] The provision of data for assessments leading to ETA, 31st EOTA Technical Board, 20-21 January 1999.

- European Standards:

LIST OF STANDARDS REFERRED TO IN THIS ETAG (ROAD BRIDGE EXPANSION JOINTS)

Standards	Clause of this ETAG	Title
EN 573	5.1.7.1.1	Aluminium and aluminium alloys – Chemical composition and form of wrought products – Part 1: Numerical designation system Part 2: Chemical symbol based designation system Part 3: Chemical composition Part 4: Form of products
EN 1504-2	5.1.7.1.4	Products and systems for the protection and repair of concrete structure – Definition, requirements, quality control and evaluation of conformity – Part 2: Surface protection systems for concrete
EN 1706	5.1.7.1.1	Aluminium and aluminium alloys – Castings – Chemical composition and mechanical properties
EN 1990 (2003)	4.1.1.4, 5.1.1.2.1, 5.1.1.2.2, 5.1.1.3.1, J.2	Eurocode – Basis of structural design
EN 1991-1-5	2.3.2	Eurocode 1: Actions on structures – Part 1-5: General actions – Thermal actions
EN 1991-2 (2004)	2.3.4, 3.2.1, 7.1, G1, G.2.1, G.2.1.4, G.2.2, G.2.2.3, G.3.1, G.3.3, Table G.6	Eurocode 1: Actions on structures – Part 2: Traffic loads on bridges
EN 1993-1-9	5.1.1.3.1	Eurocode 3: Design of steel structures – Fatigue strength of steel structures
EN 1993-2	5.1.1.3.1	Eurocode 3: Design of steel structures – Steel bridges
EN 1998-2	5.1.1.4, J1	Eurocode 8: Design of structures for earthquake resistance – Part 2: Bridges
EN 10088	4.1.7.1.1	Stainless steels – Part 1: List of stainless steels Part 2: Technical delivery conditions for sheet/plate and strip for general purposes Part 3: Technical delivery conditions for semi-finished products, bars, rods, and sections for general purposes Part 4: Technical delivery conditions for sheet/plate and strip of corrosion resisting steels for construction purposes (prEN) Part 5: Technical delivery conditions for bars, rods, wire, sections and bright products of corrosion resisting steels for construction purposes (prEN)
EN 10204	8.2.1.1.2	Metallic products – Types of inspection documents
EN 13036-4	5.1.4.2	Road and airfield surface characteristics – Test methods – Part 4: Method for measurement of slip/skid resistance of a surface – The pendulum test

EN 13687-1	5.1.7.1.4	Products and systems for the protection and repair of concrete structures – Test methods – Determination of thermal compatibility – Part 1: Freeze-thaw cycling with de-icing salt immersion
EN ISO 3506	4.1.7.1	Mechanical properties of corrosion-resistant stainless-steel fasteners
EN ISO 9001	8.2.1.1.1, 8.3	Quality management systems – Requirements
EN ISO 9002	8.2.1.1.1	Quality systems – Model for quality assurance in production, installation and servicing
EN ISO 2081	4.1.7.1	Metallic and other inorganic coatings – Electroplated coatings of zinc with supplementary treatments on iron or steel
EN ISO 10684	4.1.7.1	Fasteners. Hot dip galvanized coatings
EN ISO 11403-3	5.1.7.1.3a	Plastics – Acquisition and presentation of comparable multipoint data – Part 3: Environmental influences on properties
EN ISO 12944	4.1.7.1.1	Paints and varnishes – Corrosion protection of steel structures by protective paint systems – Part 2: Classification of environments Part 3: Design considerations Part 4: Types of surface and surface preparation Part 5: Protective paint systems
ISO 37	5.1.7.1.3a	Rubber, vulcanized or thermoplastic – Determination of tensile stress-strain properties
ISO 188	5.1.7.1.3a	Rubber, vulcanized or thermoplastic – Accelerated ageing and heat resistance tests
ISO 209	5.1.7.1.1	Wrought aluminium and aluminium alloys – Chemical composition and forms of products – Part 1: Chemical composition Part 2: Forms of products
ISO 471	5.1.7.1.3a	Rubber – Temperatures, humidities and times for conditioning and testing
ISO 1431-1	5.1.7.1.3c	Rubber, vulcanized or thermoplastic – Resistance to ozone cracking – Part 1: Static and dynamic strain testing
ISO 3522	4.1.7.1.1	Cast aluminium alloys – Chemical composition and mechanical properties
ISO 7619	5.1.7.1.3a	Rubber, vulcanized or thermoplastic – Determination of indentation hardness – Part 1: Durometer method (Shore hardness) Part 2: IRHD pocket meter method

Section one: INTRODUCTION

1. PRELIMINARIES

1.1 LEGAL BASIS

This ETAG has been established in compliance with the provisions of the Council Directive 89/106/EEC (CPD) taking into account the following steps:

- the final mandate issued by the EC : 02/10/2000 as laid down in CONSTRUCT 00/409 revised, amended at 30/11/2005 as laid down in CONSTRUCT 05/718
- the final mandate issued by the EFTA : IDEM
- adoption of the Guideline by the Executive Commission of EOTA :
- opinion of the Standing Committee for Construction :
- endorsement by the EC :

This document is published by the Member States in their official language or languages according to Article 11.3 of the CPD.

For the first one, mention "No existing ETAG is superseded".

1.2 STATUS OF ETAG

a. **An ETA is one of the two types of technical specifications** in the sense of the EC 89/106 Construction Products Directive. This means that Member States shall presume that the approved Road Bridge Expansion Joints are fit for their intended use, i.e. they enable works in which they are employed to satisfy the Essential Requirements during an economically reasonable working life, provided that:

- the works are properly designed and built,
- the conformity of the products with the ETA has been properly attested.

b. **This ETAG is a basis for ETAs**, i.e. a basis for technical assessment of the fitness for use of a Road Bridge Expansion Joint for an intended use. An ETAG is not itself a technical specification in the sense of the CPD.

This ETAG expresses the common understanding of the Approval Bodies, acting together within EOTA, as to the provisions of the Construction Products Directive 89/106 and of the Interpretative Documents, in relation to the expansion joint and uses concerned, and is written within the framework of a mandate given by the Commission and the EFTA Secretariat, after consulting the Standing Committee for Construction.

c. When accepted by the European Commission after consultation with the Standing Committee for Construction this **ETAG is binding** for the issuing of ETAs for the Road Bridge Expansion Joint for the defined intended uses.

The application and satisfaction of the provisions of an ETAG (examinations, tests and evaluation methods) leads to an ETA and a presumption of fitness of a Road Bridge Expansion Joint for the defined use only through an evaluation and approval process and decision, followed by the corresponding attestation of conformity. This distinguishes an ETAG from a harmonised European standard, which is the direct basis for attestation of conformity.

Where appropriate, Road Bridge Expansion Joints, which are outside of the precise scope of this ETAG, may be considered through the approval procedure without Guidelines according to Article 9.2 of the CPD.

The requirements in this ETAG are set out in terms of objectives and of relevant actions to be taken into account. It specifies values and characteristics, the conformity with which gives the presumption that the requirements set out are satisfied, wherever the state of the art permits and after having been confirmed as appropriate for the particular product by the ETA.

2. SCOPE

2.1 GENERAL

2.1.1 Detailed scope

This ETAG specifies the product performance characteristics, methods of verification and assessment procedures for road bridge expansion joints to ensure the products for intended use.

This Guideline concerns the expansion joints for road bridges used to ensure the continuity of the running surface as well as bearing capacity and the movement of the bridges whatever the nature of the structure constitutive material (concrete, steel, ...).

The products are designed, manufactured and installed in accordance with the ETA holder's concept and installation guide.

Expansion joints for moveable bridges are not covered by this Guideline.

2.1.2 Parts

2.1.2.1 General

This Guideline includes the following parts:

- Part 1 - General, which is common to all families of products, shall be used in conjunction with the complementary family relevant Part.
- Part 2 to 8 concerning each product family (specified according to their principle of operating) as follow:

Families of expansion joints	
	Ref. to parts
Buried expansion joints	2
Flexible plug expansion joints	3
Nosing expansion joints	4
Mat expansion joints	5
Cantilever expansion joints	6
Supported expansion joints	7
Modular expansion joints	8

According to the Annex 1 of the mandate, other product families will be specified if relevant.

2.1.2.2 Families of product

Buried Expansion Joint:

This expansion joint is formed in situ using components such as waterproofing membranes or an elastomeric pad, to distribute the deformations to a greater width and to support the surfacing which is continuous over the deck joint gap. The components of the expansion joint are situated under the surfacing.

Flexible Expansion Joint:

An in-situ poured joint comprising a band of specially formulated flexible material (binder and aggregates), which also forms the surfacing, supported over the deck joint gap by thin metal plates or other suitable components. The joint material is flush with the running surface.

Nosing Expansion Joint:

This expansion joint has lips or edges prepared with concrete, resin mortar or elastomer. The gap between the edges is filled by a flexible profile, which is not traffic load carrying.

Mat Expansion Joint:

This expansion joint uses the elastic properties of a prefabricated elastomeric strip or pad to allow the expected movements of the structure. The strip is fixed by e.g. bolts to the structure. The joint sub-component flush with the running surface.

Cantilever Expansion Joint:

This expansion joint consists of cantilever symmetrical and non-symmetrical sub-components (such as comb or saw-tooth plates), which are anchored on one side of the deck joint gap and interpenetrated to bridge the deck joint gap. The sub-components are flush with the running surface.

Supported Expansion Joint:

This expansion joint consists of one sub-component flushed with the running surface, which is fixed by hinges on one side and sliding supports on the other side (by a second element), and which spans the deck joint gap. The expected structure movement is allowed through sliding on the non-fixed side of the hinged sub-component, i.e. on the supporting element that is anchored to the substructure.

Modular Expansion Joint:

This expansion joint consists of a succession of watertight sub-components (in the traffic direction) comprising movement controlled metal beams supported by moveable substructures bridging the structural gap (i.e. cross beams, cantilevers and pantographs). The metal beams are flush with the running surface.

Note: In case of difficulty of the interpretation of these definitions, please refer to the explanation given in the family Part.

2.1.3 Relationship with European harmonized standards

Not relevant.

2.2. USE CATEGORIES AND KITS

2.2.1 Use categories

The use categories are specified with regard to the users and structure considerations. The ETA is granted for combination(s) of categories described as follow:

- User categories:
 - Vehicle,
 - Cyclist,
 - Pedestrian.
- Actions categories:
 - Standard action (See § 4),
 - Optional action (accidental effects of heavy wheel on footpath, seismic phenomena; wheel shock on the upstand, ...).

2.2.2 Kits

The expansion joint is a "kit" (as defined by EC GP C) composed of a set of at least two separate components that need to be put together to be installed permanently in the works (i.e. to become an "assembled system").

The manufacturer is responsible for all components which are part of the kit.

The kit may be supplied in two ways:

- the manufacturer supplies all components required for the installed expansion joint,
- the manufacturer supplies some of the components and specifies the others required for the installed expansion joint.

In either case the manufacturer shall specify all components for which he takes the responsibility and these shall be accessed by the Approval Body.

The manufacturer shall specify which parts of the expansion joint are replaceable (see 3.2.1 "Replaceability").

Special accessories to facilitate installation (i.e. special product for temporary obtusion of the gap in the Flexible Expansion Joint) and butt joints are a part of the "kit".

Optional devices (e.g. special adaptation for cyclists or pedestrian), shall be addressed in the ETA. In its longitudinal axis, the joint may include one or more of the following sub-assemblies:

- Expansion joint for carriageway, with or without upstand,
- Expansion joint for footpath, with or without upstand,
- Upstand of expansion joint, as a separate sub-assembly.

Each sub-assembly may be made of different design according to different family Part.

Where an expansion joint is not entirely covered by just one family Part, that joint shall be assessed according to the family Parts which are applicable.

2.3 ASSUMPTIONS

The state of the art does not permit the development, within a reasonable time, of full and detailed verification methods and corresponding technical criteria/guidance for acceptance for some particular aspects or products. This ETAG contains assumptions taking account of the state of the art and makes provisions for appropriate, additional **case-by-case approaches** when examining ETA-applications, within the general framework of the ETAG and under the CPD consensus procedure between EOTA members.

The guidance remains valid for other cases which do not deviate significantly. The general approach of the ETAG remains valid but the provisions then need to be used case by case in an appropriate way. This use of the ETAG is the responsibility of the Approval Body which receives the special application, and subject to consensus within EOTA. Experience in this respect is collected, after endorsement in EOTA-TB, in the ETAG-Format-Comprehension document.

2.3.1 Main structure

This ETAG gives recommendations for requirements concerning adequate support and method of fixing the joints to the main structure.

2.3.2 Temperatures

The following levels of minimum and maximum operating temperatures shall be considered:

- Levels of minimum operating temperatures: -10, -20, -30, -40 °C,
- Levels of maximum operating temperatures: 35, 45 °C.

Surface areas, directly exposed to the sun, have to be assessed for the maximum operating temperature increased by 15 °K.

Note: In the meaning of this ETAG, the operating temperature is assumed to be the shade air temperature according to EN 1991-1-5.

If relevant, more details on the influence of the temperature are given in the family Parts.

With respect to the required temperatures in the Member State where the expansion joint shall be used, a combination of specified levels of the minimum and maximum operating temperatures shall be chosen by the manufacturer as an operating temperature range.

2.3.3 Installation

Installation aspects, which are necessary to ensure fitness for use, are covered in Chapter 7.

2.3.4 Working life

The working life aspect is determined in conformity with "Guidance Paper F: Durability and the construction products directive" by using performance-based methods and/or descriptive solutions.

Concerning expansion joints the working life depends in particular on the external loads or the imposed movements, the cycle frequency, the number of cycles and the durability (including fatigue, wear resistance ...) of the expansion joint and its components. It is also linked with the ability to replace components and the installation quality.

Therefore in relation to the assessments given in this ETAG the manufacturer shall declare the assumed working life of the kit (including its components). The assumed working life of the kit is based on the following Working Life categories, with $N_{obs} = 0,5$ million/year (see EN 1991-2, Table 4.5 and Annex G, G3.1):

Working Life category	Years
1	10
2	15
3	25
4	50

The assumed working life of replaceable components shall be declared in the ETA.

In the family Parts, details are given about how the working life is assessed.

If, in exceptional and justified cases, a working life of less than 10 years for replaceable components is introduced in a family Part, this shall be stated in the ETA.

3. TERMINOLOGY

3.1 COMMON TERMINOLOGY AND ABBREVIATIONS

See Annex A.

3.2 TERMINOLOGY AND ABBREVIATIONS SPECIFIC TO THIS ETAG

3.2.1 Terminology

A	
Accelerated ageing	Procedure which simulates the ageing effects within a short period
Ageing	Change of material properties under the influence of environmental conditions e.g. water, nitrogen, oxygen, salt (see also Guidance Paper F)
Anchorage system	Bars and rods that connect the expansion joint to the main structure or the abutment
Asphaltic plug expansion joint	See "flexible plug expansion joint"
Axle load	The load applied on the pavement by one axle

B	
Batch	Quantity of product or components manufactured to the same specification within a determined period
Bellow	An elastic sub-component which closes a gap and ensures watertightness under gap dimensions of a designed range
Buried expansion joint	See definition given in Part 2

C	
Cantilever Expansion Joint	See definition given in Part 6
Crossing angle	The angle between the longitudinal axis of the superstructure and the river, canal, road or valley whatever it bridges

D	
Dowel	Connecting steel sub-component welded to steel parts which transmits the loads between steel parts and concrete structures
Drain	A tube which collects and transports water (not necessarily only inside the bituminous concrete)
Drainage	A system of drains and other devices, which transports water from the bridge surface

E	
Expansion joint	A structure, which provides a continuous road surface between adjacent main structures and allows the movements of these main structures

F	
Flexible plug expansion joint	See definition given in Part 3
Footpath expansion joint	An expansion joint especially designed for or modified for the use of pedestrians

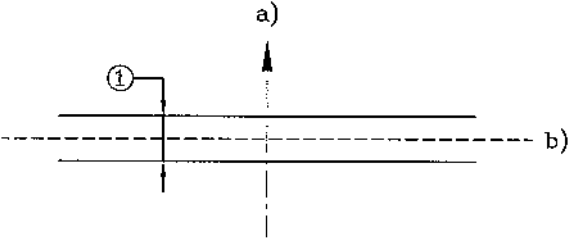
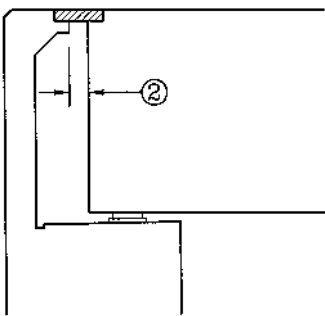
G	
<p>Gap</p> <p>1. Expansion joint gap (surface gap)</p> <p>2. Bridge deck gap (Structure gap)</p>	<p>1. Opening (generally defined by one dimension) with a great length and a relatively small width in the road surface between sub-components of the expansion joint (perpendicular distance between two straight edges or planes):</p> <p>a) Traffic direction</p> <p>b) Longitudinal axis of the expansion joint.</p>  <p><i>Note: In principle, the term gap is not restricted to straight border lines.</i></p> <p>2. Opening between two adjacent parts of the main structure, which is bridged by the expansion joint (distance between two structural elements)</p> 

H	
High strength friction grip bolts	Pre-stressed steel bolts which allow forces between adjacent parts of a structure to be transferred by friction in the contact areas of the parts being connected

I	
Impact factor (Dynamic impact factor)	A coefficient which establishes the relationship between static and dynamic loads (See EN 1991-2)

K	
Kerb	The upstand which forms the boundary of the carriage way and the footpath

L	
Lamella beam	The traffic load carrying (intermediate) beam of a modular expansion joint

M	
Mat Expansion Joint	See definition given in Part 5
Modular Expansion Joint	See definition given in Part 8
Movement capacity	The declared range of the relative displacement between the extreme positions (e.g. maximum and minimum opening) of an expansion joint

N	
Nosing expansion joint	See definition given in Part 4

O	
Operating temperature	Temperature of the components of the kit

P	
Pantograph support	A mechanical support structure with bars and hinges for the runners in modular expansion joints which transmits the traffic loads, guides and stabilizes the runners
Prestress anchorage	Anchorage which introduces a preload

R	
Range (1)	Products with similar characteristics and a variety of dimensions or components
Range (2)	The dilatation capacity of an element
Recess	The specific opening over the expansion gap created by the installer/designer in order to receive the expansion joint kit
Reinforcement	Steel bars in concrete
Replaceability	The ability to replace is given when a component, incorporated in the assembled expansion joint, can be exchanged during the assumed working life of the expansion joint in an easy and economically reasonable way
Riding quality	The effect of the joint on vehicles travelling over it

Rolling friction	The relationship between the vertical force on a wheel and the horizontal force needed for movement of the wheel resulting from wheel and support area deformation
Rolling shutter plate	Sliding plate on roller bearings which closes a gap

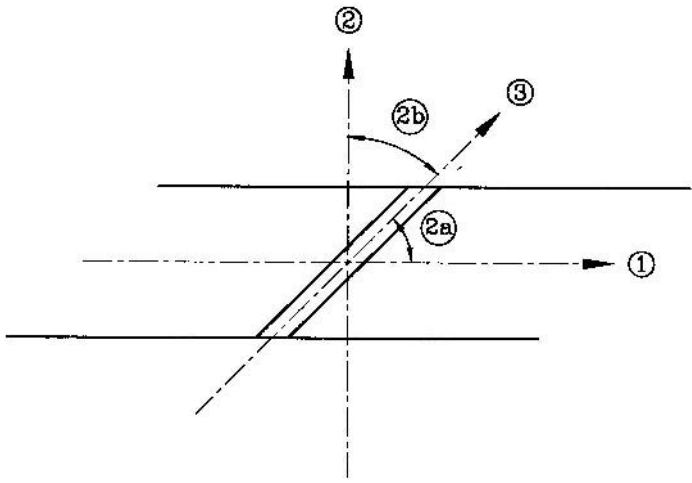
S	
Sample	One unit of a batch from which a test piece is taken
Seal	A flexible sub-component which ensures the watertightness
Single Seal Expansion Joint	An expansion joint with a single bellow
Shutter 1. Rolling shutter 2. Sliding shutter	Rolling (1) or Sliding (2) plate that covers the expansion joint gap
Settlements	Irreversible movements of the main structure due to deformation of the soil foundation under continuous loading
Skew angle (of the expansion joint)	<p>Considering the existence of two interpretations of the skew of the bridge in Member States, it has two definitions:</p> <p>a) the skew angle is the angle between the road axis and the longitudinal axis of the joint,</p> <p>b) the skew angle is the angle between the axis perpendicular to the road and the longitudinal axis of the joint.</p> <p>The manufacturer will indicate the definition chosen.</p>  <p>1: Traffic direction. 2: Perpendicular to the road axis. 3: Expansion joint axis. 2a and 2b: Bridge angle.</p>
Skid resistance	Force generated by friction between the vehicle tyre and the expansion joint
Socket (for a bolt)	Sub-component with thread that functions as a nut and a connection to concrete or masonry
Suction effects	The suction effect caused by separation of the wheel tyre and the expansion joint surface
Supported Expansion Joint	See definition given in Part 7

T	
Temperature	See operating temperature
Template	An auxiliary structure which ensures the right positioning of fixing elements in a concrete structure or the right positioning of drilled holes
Test piece	Part of the sample from which test specimens are taken
Test specimen	Piece of accurate dimension taken from test piece
Traffic	All road users: vehicles, cyclists, motorists, equestrians, pedestrians
Traffic classes	Vehicle and other user categories with similar effects or loads on the expansion joint
Transition strip	Filler material between the expansion joint and the adjacent surfacing

U	
Upstand	The vertical or inclined part of the joint which ensures continuity of the joint between road surface level and footway level

V	
Void	An opening in the road surface (generally defined by two dimensions) with no bearing capacity

W	
Wear	The loss of material due to friction between two parts of the expansion joint or between a part of the expansion joint and the structure

3.2.2 Abbreviations

See Annex G.

Section two: GUIDANCE FOR THE ASSESSMENT OF THE FITNESS FOR USE

GENERAL NOTES

(a) Applicability of the ETAG

This ETAG provides guidance on the assessment of a family of Road Bridge Expansion Joints and their intended uses. It is the manufacturer or producer who defines the expansion joint for which he is seeking an ETA and how it is to be used in the works, and consequently the scale of the assessment.

It is therefore possible that for some Road Bridge Expansion Joint, which are fairly conventional, only some of the tests and corresponding criteria are sufficient to establish fitness for use. In other cases, e.g. special or innovative Road Bridge Expansion Joint or materials, or where there is a range of uses, the whole package of tests and assessment may be applicable.

(b) General lay out of this section

The assessment of the fitness of Road Bridge Expansion Joints with regard to their fitness for intended use in construction works is a process described in three main chapters:

- Chapter 4 clarifies **the specific requirements for the works** relevant to the Road Bridge Expansion Joint and uses concerned, beginning with the Essential Requirements for works (CPD Article 11.2) and then listing the corresponding relevant characteristics of Road Bridge Expansion Joint.

- Chapter 5: extends the list in chapter 4 into more precise definitions and the **methods available to verify product** characteristics and to indicate how the requirements and the relevant **product** characteristics are described. This is done by test procedures, methods of calculation and of proof, etc. (selection of the appropriate methods).

- Chapter 6 provides guidance on **the assessing and judging methods** to confirm fitness for the intended use of the Road Bridge Expansion Joint.

Chapter 7, **assumptions and recommendations** are only relevant in as far as they concern the basis upon which the assessment of the Road Bridge Expansion Joint is made concerning their fitness for the intended use.

(c) Levels or classes related to the essential requirements and to the product performance (see each ID clause 1.2 and EC Guidance Paper E)

According to the CPD "Classes" in this ETAG refer only to mandatory levels or classes laid down, in the EC-mandate.

This ETAG indicates the compulsory way of expressing relevant performance characteristics for the Road Bridge Expansion Joint. If, for some uses at least one Member State has no regulations, a manufacturer always has the right to opt out of one or more of them, in which case the ETA will state "no performance determined" against that aspect, except for those properties for which, when no determination has been made, the Road Bridge Expansion Joint no longer falls under the scope of the ETAG; such cases shall be indicated in the ETAG.

(d) Working life (durability) and serviceability

The provisions, test and assessment methods in this Guideline or referred to, have been written, based upon the assumed intended working life of the Road Bridge Expansion Joint for the intended use according to 2.3.4, provided that the Road Bridge Expansion Joint is subject to appropriate use and maintenance (cf. Chapter 7). These provisions are based upon the current state of the art and the available knowledge and experience.

An "assumed intended working life" means that it is expected that, when an assessment following the ETAG-provisions is made, and when this working life has elapsed, the real working life may be, in normal use conditions, considerably longer without major degradation affecting the essential requirements.

The indications given as to the working life of a Road Bridge Expansion Joint cannot be interpreted as a guarantee given by the producer or the Approval Body. They should only be regarded as a means for the specifiers to choose the appropriate criteria for Road Bridge Expansion Joint in relation to the expected, economically reasonable working life of the works (based upon each ID par. 5.2.2).

(e) Fitness for the intended use

According to the CPD it has to be understood that within the terms of this ETAG, products shall "have such characteristics that the works in which they are to be incorporated, assembled, applied or installed, can, if properly designed and built, satisfy the Essential Requirements" (CPD, Article 2.1).

Hence, the Road Bridge Expansion Joint "must be suitable for use in construction works which (as a whole and in their separate parts) are fit for their intended use, account being taken of economy, and in order to satisfy the essential requirements. Such requirements must, subject to normal maintenance, be satisfied for an economically reasonable working life. The requirements generally concern actions which are foreseeable." (CPD Annex I, preamble).

4. REQUIREMENTS

for works, and their relationship to the Road Bridge Expansion Joint characteristics

This chapter sets out the aspects of performance to be examined in order to satisfy the relevant Essential Requirements, by:

- expressing in more detail, within the scope of the ETAG, the relevant Essential Requirements of the CPD in the Interpretative Documents and in the mandate, for works or parts of the works, taking into account the actions to be considered, as well as the expected durability and serviceability of the works,
- applying them to the scope of the ETAG (product and where appropriate its constituents, components and intended uses), and providing a list of relevant Road Bridge Expansion Joint characteristics and other applicable properties.

When a product characteristic or other applicable property is specific to one of the Essential Requirements, it is dealt with in the appropriate place. If, however, the characteristic or property is relevant to more than one Essential Requirement, it is addressed under the most relevant one with cross-reference to the other(s). This is especially important where a manufacturer claims "No performance determined" for a characteristic or property under one Essential Requirement and it is critical for the assessing and judging under another Essential Requirement. Similarly, characteristics or properties which have a bearing on durability assessments may be dealt with under ER 1, ER 3 and ER 4, with reference under 4.7. Where there is a characteristic which only relates to durability, this is dealt with in 4.7.

This chapter also takes into account further requirements, if any (e.g. resulting from other EC Directives) and identifies aspects of serviceability including specifying characteristics needed to identify the Road Bridge Expansion Joint.

4.0 TABLE LINKING THE ESSENTIAL REQUIREMENTS TO ROAD BRIDGE EXPANSION JOINT PERFORMANCE

Comprehensive table

ER	ID #	ID clause for the works	Element involved*	Performance of the element (with reference to the ID)	Characteristics specified in the mandate	Corresponding characteristics in the WP	Test or evaluation method
1	1	CPD Annex 1 a) Collapse of the whole or part of the works. b) Major deformation to an inadmissible degree. d) Damage by an event to an extent disproportionate to the original cause.			Mechanical resistance		§ 4.1.1.2
					Resistance to fatigue		§ 4.1.1.3
					Seismic behaviour		§ 4.1.1.4
					Movement capacity		§ 4.1.1.5
					Cleanability		§ 4.1.1.6
					Resistance to wear		§ 4.1.1.7
					Watertightness		§ 4.1.1.8
2					Not relevant		
3					Release of dangerous substances		§ 4.1.3.1
4	4	ID 3.3.6.2: Accidents resulting from vehicle movement.			Allowable surface gaps and voids		§ 4.1.4.1.1
					Level differences in the running surface		§ 4.1.4.1.2
					Skid resistance		§ 4.1.4.2
					Drainage capacity		§ 4.1.4.3
5					Not relevant		
6					Not relevant		
					Durability of the characteristics against: Corrosion, ageing, chemicals, temperature, UV-radiation, freeze-thaw, ozone		§ 4.1.7

4.1 KITS

4.1.1 Mechanical resistance and stability

4.1.1.1 General

The expansion joint shall be designed and built in such a way that the loads and imposed deformations/displacements that are liable to act on it during construction and use of the works will not lead to any of the following:

- collapse of the whole or a part of the works,
- major deformations to an inadmissible degree,
- damage by an event to an extent disproportionate to the original cause.

This clause gives the aspects for mechanical resistance and stability as well as the connection to the relevant actions due to traffic and other sources, to be taken from the relevant European Standards (Eurocodes) and the National Application Documents as far as they exist.

External loads on expansion joints are generated by traffic. Further loads on expansion joints may be generated as internal loads from imposed deformations or displacements or change of temperature of the joint itself.

Table 4.1.1 gives details of the general criteria given before.

Table 4.1.1: Limit state and assessment criteria definition

Limit State	Limit State requirement	Remark
ULS	Static equilibrium (detailed, if necessary, in the family Part).	The expansion joint includes its anchoring system.
	No fatigue failure during the intended working life (see 2.3.4). (Stress ranges below constant amplitude fatigue limit [CAFL] or cumulative damage assessment $D < 1,0$).	
SLS	Only reversible deformations, displacement or rotation (hysteresis effects or similar due to material behaviour are allowed).	

ULS criteria for the joint under imposed displacements at ULS of the main structure are detailed in the relevant family Part.

4.1.1.2 Mechanical resistance

4.1.1.2.1 General

The requirements in Table 4.1.1 for ULS apply. Whether SLS in Table 4.1.1 applies is stated in the family Parts.

4.1.1.2.2 Actions

The actions, loads and combination in relation to the user and actions categories described in 2.2.1 are given in Annex G of this ETAG.

4.1.1.3 Resistance to fatigue

4.1.1.3.1 General

The expansion joint shall have sufficient fatigue resistance with respect to its intended working life. The requirements in Table 4.1.1 for ULS apply.

4.1.1.3.2 Actions for fatigue assessment

The actions, loads and combination are given in Annex G of this ETAG.

4.1.1.4 Seismic behaviour

Design requirements under seismic conditions consider the importance of the bridge and of the expansion joint. Different approaches A and B are given in order to achieve this objective. They consider different behaviours under and after seismic conditions, giving corresponding values of d_{ek} and A_{ed} . These approaches are further subdivided into approaches A1, A2 (movement capacity design approach) and B1, B2, B3, B4 (restricted movement and load capacity design approach). No fatigue design check is required for these approaches.

The requirements are associated with each approach and are summarized below.

A1 and A2. The expansion joint is not affected by seismic actions under loading conditions defined in G.4.2.3.

B1. No damage with reduced load bearing capacity and increased gap width during earthquake. $C_{ULS-SEISMIC}$ according to the seismic design combination B1 (see G.4.2.3).

B2. Minor damage to secondary sub-components and non load carrying sub-components. Load carrying sub-components are allowed to have a reduced load bearing capacity and increased gap width under the seismic design situation.

Secondary sub-components and non load carrying sub-components (e.g. seal sub-components) are allowed to be damaged. Both of these sub-components shall be replaceable or repairable after the earthquake. For the other design requirements see approach B1.

B3. Minor damage to primary sub-components or fusible devices due to a combination of reduced traffic load bearing capacity and increased gap width during earthquake. The resistance of load carrying structural elements shall be checked for the seismic design situation **C_{ULS-SEISMIC}** (see G.4.2.3).

The expansion joint is assumed to be resistant to frequent traffic loads according to EN 1990 after the earthquake and to fulfil all the Ultimate and Serviceability Limit State requirements after small repairs.

The sub-components with minor damage shall be easily replaceable with no need of immediate repair.

B4. Major damage to fusible devices and minor damage on the joint. No remaining load bearing capacity and increased gap width after the earthquake.

The combinations of loads defined in G.4.2.3 shall be used to verify the resistance of load carrying structural elements during the earthquake.

The detailing of expansion joint parts to be damaged during the design seismic event has to be provided with the predictable mode of failure.

The possibility of permanent repair shall be described.

These fusible devices should avoid or minimize damage on the structural elements of the bridge reducing at the mean time the required size of the expansion joint.

In the case of emergency traffic after the seismic event, the expansion joint shall comply with approach B3 load carrying requirements and the width (in the traffic direction) of possible gaps shall be as a maximum 300 mm.

Note: Occurring level differences may cause the need for temporary measures enabling the emergency vehicles to pass the joint at slow speed. Short-term repairs may be required.

Table 4.1.1.4

Approach	Requirement	During design earthquake		After design earthquake	
		Actions	Safety in use	Load bearing capacity and Serviceability	Expected repair work
A	Full movement capacity				
A.1	Movement capacity at SLS condition even during the earthquake	Fundamental combination Annex G.4.2.1	As for the SLS condition	As before the earthquake	None
A.2	Movement capacity for the total displacement d_{Ed}	Frequent combination Annex G.4.2.3	Maximum gap (1) 160 mm	As before the earthquake	None
B	Limited movement and load capacity design				
B1	No damage but reduced load capacity during earthquake	Seismic design Annex G.4.2.3	Maximum gap (1) 160 mm	As before the earthquake	None
B2	Minor damage to secondary elements and reduced load capacity during earthquake	Seismic design Annex G.4.2.3	Maximum gap (1) 160 mm	Load capacity as before the earthquake	Replacement of secondary elements
B3	Minor damage to structural elements or fusible devices and reduced load capacity during earthquake	Seismic design Annex G.4.2.3	Maximum gap (1) 240 mm	Original behaviour after small repairs	Small repairs on structural elements and fusible devices
B4	Damage to fusible devices and no load carrying capacity after the earthquake	Seismic design combination Annex G.4.2.3	No gap (1) limitation	Maximum gap 300 mm for Emergency Traffic	Permanent repair required

(1) Gap = Expansion joint gap

If applicable both longitudinal, transversal and vertical seismic displacements and their combination shall be considered.

The seismic movement capacity of the joint is extended to values greater than the requirements of 4.1.4.1.1. Limitations for gaps and voids during the seismic event in the running surface are given in the table above or in the parts related to the families.

4.1.1.5 Movement capacity

The nominal movement capacity of an expansion joint is the possibility to allow the displacement of the parts of the main structure under unloaded and loaded conditions as given in Annex G.

The movement capacity shall be assessed for 3 directions: longitudinal, transversal and vertical.

The displacement velocity and the temperature may affect the response of the different joints. The influence of these parameters is addressed in Parts 2 to 8 where relevant.

Where relevant, additional allowance for displacements and corresponding rotation is specified in the family Parts.

The declared movement capacity is accompanied by a declaration of the minimum opening position.

4.1.1.6 Cleanability

The proper functioning of the expansion joint shall not be affected by accumulation of debris. The cleanability can either be achieved by a good design or by good accessibility to allow removal of debris.

Sufficient accessibility to the drainage system for flushing and maintenance shall be provided.

4.1.1.7 Resistance to wear

The intended working life of the kit shall not be affected by wear which is caused by movements either between two parts of the joint or between parts of the joint and the main structure.

Components with a shorter assumed working life than the kit, caused by wear, shall be replaceable.

Where relevant, the influence of the wear is addressed in Parts 2 to 8 and shall be stated in the ETA.

4.1.1.8 Watertightness

The main structure and where relevant the sub-components of the joint under the running surface shall be protected from water and its chemical contents.

There are two alternatives:

- by a watertight joint itself,
- or by a sub-surface drainage system.

4.1.2 Safety in case of fire

Not relevant.

4.1.3 Hygiene, health and environment

4.1.3.1 Release of dangerous substances

The expansion joint shall be such that, when installed according to the appropriate provisions of the Member States, it allows for the satisfaction of the ER3 of the CPD as expressed by the national provisions of the Member States and in particular does not cause harmful emission of toxic gases, dangerous particles or radiation to the indoor environment nor contamination of the outdoor environment (air, soil or water).

4.1.4 Safety in use

The safety in use requirements ensure that road users can travel without danger or injury over the expansion joint throughout the intended working life of the joint.

The safety in use includes the following characteristics under SLS condition: bridging gaps, levels and skid resistance, the latter which is influenced by the roughness of the joint surface and its drainage capacity.

4.1.4.1 Ability to bridge gaps and levels in the running surface

4.1.4.1.1 Allowable surface gaps and voids

The maximum dimensions of the gaps and voids of the joint at the surface level depend on the three user categories.

For vehicles and cyclists categories the expansion joint shall not allow a vertical displacement of more than the radius of a 10 cm diameter sphere placed anywhere on the running surface level.

a) Vehicles

The expansion joint shall not allow a vertical displacement of 1 cm or more of the following bodies, in conjunction with the traffic direction:

- a horizontal prism with plan dimensions 10 cm by 20 cm placed horizontally anywhere and in any direction,
- a horizontal prism with plan dimensions 6,5 cm by 22 cm placed horizontally anywhere with a deviation from the traffic direction of -20° to $+20^\circ$,
- a horizontal prism with plan dimensions 4,5 cm by 35 cm placed horizontally anywhere with a deviation from the traffic direction of -20° to $+20^\circ$.

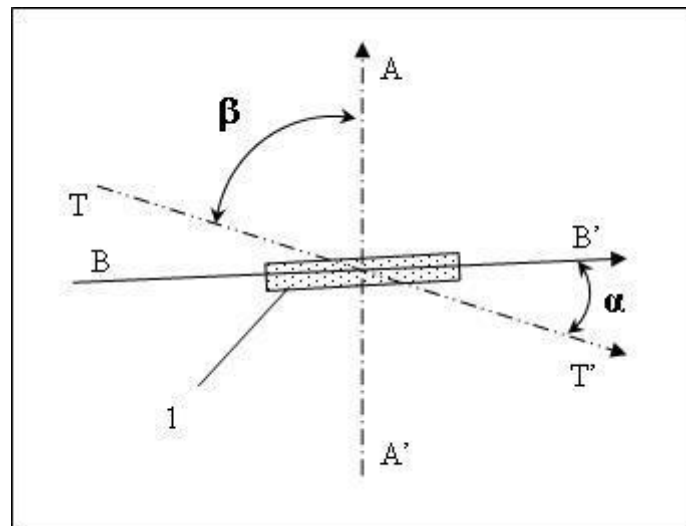

Key

TT': Traffic direction, AA': Expansion joint axis, BB': Orientation of the block, 1: Block

Figure 4.1.4.1.1: Assessment of the allowable gaps and voids

The manufacturer shall declare the range of the angle between the traffic direction and the longitudinal axis of the expansion joint to fulfil this requirement.

b) Cyclists

The expansion joint shall not allow a vertical displacement of 1 cm or more of the following bodies, in conjunction with the traffic direction:

- a horizontal prism with plan dimensions 2 cm by 22 cm placed horizontally everywhere with a deviation from the traffic direction of -20° to $+20^\circ$,
- a horizontal prism with plan dimensions 10 cm by 20 cm placed horizontally everywhere and in any direction.

The manufacturer shall declare the range of β , the angle between the traffic direction and the longitudinal axis of the expansion joint (see Figure in gap definition), to fulfil this requirement.

Note: These rules are valid for cyclist and small motorcycles.

The design of the expansion joint for the carriageway can be adapted by special measures to fulfil the above requirement (see also 2.2.2).

c) Pedestrians

The expansion joint shall not allow a vertical displacement of 2 cm or more of a disk with a diameter of 8 cm placed horizontally everywhere.

4.1.4.1.2 Level differences in the running surface

Without any imposed horizontal deformations and in unloaded condition the difference in the levels of the running surface of the joint from the ideal connection line between the two adjacent pavements in the traffic direction shall not be greater than 5 mm. Steps shall not be greater than 3 mm (without considering surface texture and discontinuities due to gaps and voids).

This rule is applied in a horizontal position.

After loading, level differences shall not be more than the value observed during mechanical resistance and stability in 4.1.1 in the case of static loading and not more than 12 mm.

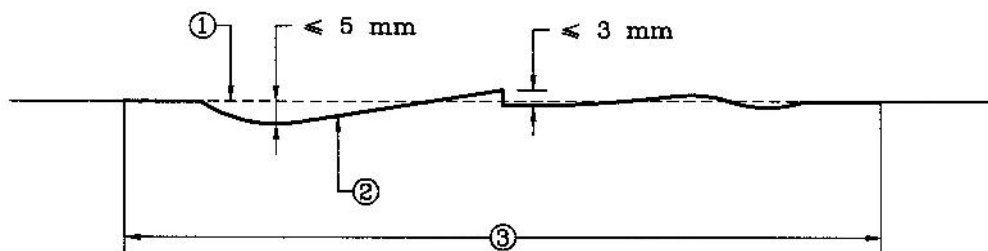

- ① Ideal connection line
- ② Running surface of the joint
- ③ Expansion joint

The level differences could be in the opposite direction.

Figure 4.1.4.1.2: Example of level difference

4.1.4.2 Skid resistance

The design of the joint and its trafficked surface shall be such that under normal condition no hazard will be caused to the road users.

a) Carriageway

For flat surfaces larger than a 150 x 150 mm square without relief (surface texture) in excess of $\pm 1,2$ mm testing is required.

b) Footpath

For flat surfaces larger than a 150 x 150 mm square without relief (surface texture) in excess of $\pm 1,2$ mm and the requirement is not met by special design (e.g. chequered plate) verification by testing is required.

4.1.4.3 Drainage capacity

The design of the joint shall prevent standing water, from rain or melting snow.

This requirement may be met by the transverse slope of the running surface. When required by a Member State's regulation, a drainage system shall be provided. Drainage can be achieved by surface and/or sub-surface drainage systems.

4.1.5 Protection against noise

Not relevant.

4.1.6 Energy economy and heat retention

Not relevant.

4.1.7 Aspects of durability, serviceability and identification of the products

This sub-section contains requirements as far as necessary for the satisfaction of the CPD not covered by 4.1.1 to 4.1.6.

4.1.7.1 Aspects of durability

The durability of the expansion joint depends mainly on the durability of its components, the materials used, the achieved quality at manufacture and the achieved quality of installation and the proper maintenance.

The expansion joint shall have sufficient resistance to the effects of potential degradation factors to ensure that deterioration of materials and components during the intended working life does not significantly affect the performance of the kit in relation to fulfilling all the Essential Requirements 1, 3 and 4.

The aspects related to the durability of a Road Bridge Expansion Joint, and which shall be taken into account, are:

- Corrosion

Unless intrinsically corrosion resistant, metallic components for products according to the different family parts are considered to be affected by corrosion and all metallic surfaces have to be protected.

The atmospheric corrosivity categories to be considered are C4, C5-I or C5-M according to EN ISO 12944-2, whereas for the durability of the protective paint system the durability ranges "medium (M)" or "high (H)" according to EN ISO 12944-5 apply, depending on the declared working life category according to 2.3.4 in this Part 1 of ETAG 032.

Structural steel surfaces in contact with concrete shall have no coating. Only at the transitions an overlap of approximately 50 mm of the full corrosion protection system shall be applied.

The provision regarding the durability range, made in the European Technical Approval, is not a “guarantee time”. This shall be stated in the European Technical Approval.

In case of use of stainless steel for components, the grade of steel shall be 1.4401, 1.4404 or 1.4571 in accordance with EN 10088, or equivalent (e.g. EN ISO 3506 for stainless steel bolts).

Aluminium alloys shall have a corrosion resistance of at least category “B” according to ISO 3522, Table C.1, or equivalent. Furthermore, interaction between concrete and the aluminium alloy shall be prevented.

Permanent steel bolts shall at least be:

- electrolytic zinc plated, then after tightening coated with Fe/Zn 25 in acc. with EN ISO 2081 or
- hot dip galvanized in accordance with EN ISO 10684.

or be made of:

- austenitic steel in accordance with EN ISO 3506 with grade A2 or higher for non marine (non-saline) environment and grade A4 or higher for marine (saline) environment.

Temporary bolts may be unprotected.

- Chemicals

The concentration of oil, petrol, fuel oil or de-icing salts on a bridge under normal service conditions shall not affect the expansion joint durability.

- Loss of performance due to ageing resulting from temperature, UV radiation and ozone

The required performance of the expansion joint shall not be affected by ageing. This applies to elastomer and plastic components (as defined in the relevant family Part) for temperature and for ozone. This applies also for a layer of resin exposed to direct UV ray when its thickness is less than 1 mm.

- Resistance against freeze-thaw
- Susceptibility of porous materials (e.g. concrete mortar) to freeze-thaw damage
- Durability aspects of other materials shall be demonstrated by the manufacturer in a suitable manner

Other aspects of durability not stated above are determined in the family Part, if relevant.

The fatigue and wear aspects are covered in 4.1.1.3 and 4.1.1.7.

4.1.7.2 Aspects of serviceability

The manufacturer shall submit information for the installation, inspection and maintenance to the Approval Body.

Components indicated in the ETA with a shorter assumed working life than the expansion joint shall be accessible for inspection and shall be replaceable.

Guidance for accessibility for inspection of the expansion joint is given in the family Part, where relevant.

4.1.7.3 Aspects of identification

The expansion joint and/or its components shall be identified (marking is covered in 8.4). The aspects to be identified are given in the relevant family Parts.

4.2 COMPONENTS

The components may consist of smaller parts which are called sub-components. These Sub-components may be standardized products or special products developed of specified materials. They are assembled in the factory production process to form the component.

The manufacturer shall declare the components that are included in the kit and shall specify the sub-components and material characteristics and, where applicable, their tolerances. Detailed requirements are stated in the relevant family Parts.

It shall be indicated which components or which sub-components are replaceable.

5. METHODS OF VERIFICATION

This chapter refers to the verification methods used to determine the various aspects of performance of the expansion joints in relation to the requirements for the works (calculations, tests, engineering knowledge, site experience, etc.) as set out in Chapter 4.

The possibility exists to use existing data in accordance with the EOTA Guidance Document No 004 on “The provision of data for assessment leading to ETA”.

When EUROCODES are quoted in this ETAG as the methods for the verification of certain characteristics, their application in this ETAG, as well as in the subsequent ETAs issued according to this ETAG, shall be in accordance with the principles laid down in the EC Guidance Paper on the use of EUROCODES in harmonised European technical specifications.

5.0 GENERAL

ER	ID clause for the works	Characteristics specified in the mandate and corresponding characteristics in the WP	Test or evaluation method
1	CPD Annex 1 a) Collapse of the whole or part of the work. b) Major deformation to an inadmissible degree. d) Damage by an event to an extent disproportionate to the original cause.	Mechanical resistance	§ 5.1.1.2
		Resistance to fatigue	§ 5.1.1.3
		Seismic behaviour	§ 5.1.1.4
		Movement capacity	§ 5.1.1.5
		Cleanability	§ 5.1.1.6
		Resistance to wear	§ 5.1.1.7
		Watertightness	§ 5.1.1.8
2		Not relevant	
3		Release of dangerous substances	§ 5.1.3
4	ID 3.3.6.2: Accidents resulting from vehicle movement.	Allowable surface gaps and voids	§ 5.1.4.1.1
		Level differences in the running surface	§ 5.1.4.1.2
		Skid resistance	§ 5.1.4.2
		Drainage capacity	§ 5.1.4.3
5		Not relevant	
6		Not relevant	
		Durability of the characteristics against: Corrosion, ageing, chemicals, temperature, UV-radiation, freeze-thaw, ozone	§ 5.1.7.1

5.1 KITS

5.1.1 Mechanical resistance and stability

5.1.1.1 General

For the verification of mechanical resistance, resistance to fatigue and wear, the methods given in this ETAG shall be used. These methods may need to be supplemented by reference to additional standards (EN or ISO standards or national standards). In the absence of standards, assessment procedures, appropriate (as agreed by the Approval Body and the manufacturer) to prove these characteristics, shall be used.

5.1.1.2 Mechanical resistance

Mechanical resistance shall be demonstrated by calculations, testing or a combination of both. The design loads shall be derived from the traffic loads in Chapter 4 and Annex G.

5.1.1.2.1 Calculations

The structure shall be modelled in such a way that the model represents the real structure.

The partial factors γ_M shall be determined either:

- in accordance with 6.3 of EN 1990:2003 and,
- where relevant, using the recommended values given in the relevant Eurocode, or its national annex.

The value used by the manufacturer shall be declared in the ETA.

It is allowed to calculate the 3-dimensional behaviour with 2-dimensional models when care is taken that the appropriate boundary conditions and eccentricities are used. When springs are represented by rigid supports, the assumption shall be justified by parameter calculations.

5.1.1.2.2 Testing

The manufacturer and the Approval Body shall define an appropriate regime which allows the performance to be derived from testing in an appropriate manner. Any of the testing types given in Annex D.3 (1) of EN 1990:2003 may be applied.

Note: In cases where the interpretation of the principles of EN 1990 for similar ETA applications might lead to different approaches in obtaining the product performances, it is recommended to consult Approval Bodies, working in the same field, on the test regime.

The test specimen dimensions and the boundary conditions shall be selected in such a way that the structural behaviour complies with the behaviour in a real structure.

The test loads shall be derived from Annex G.

The test methods are given in the family Parts.

5.1.1.3 Resistance to fatigue

Fatigue resistance shall be demonstrated by calculation, testing or a combination of both. The design loads shall be determined using the traffic loads in Chapter 4 and Annex G, whereas for the load distribution, either the distribution given in Annex G applies or if results from dynamic tests show another load distribution, this distribution may be used.

Where relevant due to the design, the dynamic response of the expansion joint, due to unevenness of their running surface and dynamic interaction such as upswing and damping, shall be considered. For this aspect, the possibilities, in each relevant family Part, are the following:

- a) Reduce the amplification factor.
- b) Modify the number of cycles.

Based on:

- Specific analysis of the expansion joint, case by case (see also Annex G, G.3.3),
- Statement covering all the products in the relevant Part.

Note: The fatigue resistance assessment procedure may differ for each family.

5.1.1.3.1 Calculations

The partial factors for fatigue shall be determined either:

- in accordance with 6.3 of EN 1990:2003, or,
- where relevant, using the recommended values given in the relevant Eurocode, or its national annex.

The value used by the manufacturer shall be declared in the ETA.

The structure shall be modelled in such a way that the model gives reliable results for the intended working life.

It is allowed to calculate the intended working life with fatigue detail classifications determined in accordance with EN 1993-1-9 and EN 1993-2.

5.1.1.3.2 Testing

It is not possible to give definitive guidance for the derivation of mechanical resistance based on testing, because this depends on many factors such as the design of the joint, the design of the test, and existing knowledge about the material and/or component properties.

Note: In cases where the interpretation of the principles of EN 1990 for similar ETA applications might lead to different approaches in obtaining the product performances, it is recommended to consult Approval Bodies, working in the same field, on the test regime.

The manufacturer and the Approval Body shall define an appropriate regime which allows the performance to be derived from testing in an appropriate manner. Any of the testing types given in Annex D.3 (1) of EN 1990:2003 may be applied.

The test specimen dimensions and the boundary conditions shall be selected in such a way that the structural behaviour complies with the behaviour in a real structure.

The test loads shall be derived from Annex G.

The test methods are given in the family Parts.

5.1.1.4 Seismic behaviour

The seismic behaviour shall be demonstrated for the selected approach given in Chapter 4 and/or by analysis of the design of the expansion joint using the principles of Annex J and EN 1998-2.

5.1.1.5 Movement capacity

The nominal movement capacity under unloaded conditions declared by the manufacturer shall be demonstrated.

The nominal movement capacity shall be verified by testing. The test method is described in Annex K.

Where relevant, due attention shall be paid to the rotations. The verification of this phenomenon will in most cases be limited to an analysis of the design.

Note: Some types of joints may not need testing for movement capacity evaluation, e.g. joints without a connection between the two parts of the main structure like a seal.

5.1.1.6 Cleanability

Cleanability shall be verified by check of the design principles or, in case of doubt about the performance of the proposed design, by an additional test to the test of the movement capacity, by depositing sand on the joint and verifying the removal of the sand under opening/closing movements of the joint.

As an alternative, a good accessibility for cleaning has to be verified by analysis of the technical file of the expansion joint.

Note: It is recommended to take into account experience with existing products for the verification.

The details of the method of assessment and the results (e.g. "pass" according to the method used), together with any measures that need to be taken to maintain the cleanliness, shall be given in the evaluation report.

5.1.1.7 Resistance to wear

The resistance to wear shall be demonstrated by testing as defined in the relevant family Parts.

5.1.1.8 Watertightness

For the verification of the watertightness of the joint itself, the test method is described in Annex L.

Where a watertight connection between the waterproofing system of the main structure and the expansion joint exists, this shall be assessed. The verification shall be carried out during the watertightness verification of the joint itself using Annex L, but including, in the test specimen, this connection and a representative portion of the waterproofing system of the main structure. The type of the connection shall be described in the ETA.

Note: When a joint has a sub-surface drainage system, its drainage capacity is verified according to 5.1.4.3.

5.1.2 Safety in case of fire

Not relevant.

5.1.3 Hygiene, health and environment

5.1.3.1 Presence of dangerous substances in the product

The applicant shall submit a written declaration stating whether or not the product/kit contains dangerous substances according to European and national regulations, when and where relevant in the Member States of destination, and shall list these substances.

5.1.3.2 Compliance with the applicable regulations

If the product/kit contains dangerous substances as declared above, the ETA will provide the method(s) which has been used for demonstrating compliance with the applicable regulations in the Member States of destination, according to the EU data-base (method(s) of content or release, as appropriate).

5.1.3.3 Application of the precautionary principle

An EOTA member has the possibility to provide to the other members, through the Secretary General, warning about substances which, according to Health authorities of its country, are considered to be dangerous under sound scientific evidence, but are not yet regulated. Complete references about this evidence will be provided.

This information once agreed upon, will be kept in an EOTA data base, and will be transferred to the Commission services.

The information contained in this EOTA data base will also be communicated to any ETA applicant.

On the basis of this information, a protocol of assessment of the product, regarding this substance, could be established on request of a manufacturer with the participation of the Approval Body which raised the issue.

5.1.4 Safety in use

5.1.4.1 Ability to bridge gaps and levels in the running surface

5.1.4.1.1 Allowable surface gaps and voids

Verification shall be carried out by analysis of the technical file and, when needed, by use of measurements tools given to 4.1.4.1.1.

5.1.4.1.2 Level differences in the running surface

Verification shall be carried out by analysis of the technical file and drawings of the expansion joint. For other related or additional requirements, to be stated in the family Part according to 4.1.4.1.2, the verification method is given in the family Part.

5.1.4.2 Skid resistance

If required, the skid resistance of the expansion joint shall be verified by the portable skid resistance pendulum tester as described in EN 13036-4 using the CEN Rubber slider for carriageways and the 4S rubber slider for footpaths. For both, the normal slider width of 76,2 mm shall be used.

If the test method according to EN 13036-4 is not applicable, either a different appropriate test method shall be used, or the manufacturer shall give an alternative specification of how skid resistance is satisfied. The details and the correlation with EN 13036-4 shall be given in the evaluation report.

5.1.4.3 Drainage capacity

If relevant, the discharge capacity (for closed and maximum opening) shall be assessed either by calculation (based on analysis of technical file and drawings) or testing.

5.1.5 Protection against noise

Not relevant.

5.1.6 Energy economy and heat retention

Not relevant.

5.1.7 Aspects of durability, serviceability and identification of the products

This sub-section contains requirements as far as necessary for the satisfaction of the CPD not covered by 5.1.1 to 5.1.6.

5.1.7.1 Aspects of durability

The assessment of the durability can be carried out by direct or indirect testing, historical data, prescriptive description of component materials and design, taking into account the influence of climatic conditions, etc.

5.1.7.1.1 Corrosion

The selected corrosion protection system shall be verified according to the relevant standards, indicated in 4.1.7.1.1.

For structural steel surfaces in contact with concrete it shall be verified that the corrosion protection layout for the concerned kit conforms to the requirement according to 4.1.7.1. In addition, the requested overlap according to 4.1.7.1 shall be verified according to the technical drawings.

The equivalence of alternative aluminium alloys shall be verified by means of the relevant standards (see EN 1706, EN 573, ISO 209 etc.).

It shall be verified by proof of the indications of the manufacturer in the technical documentation, that no interaction between aluminium and concrete can take place.

For steel bolts it shall be verified that the selected materials and system for corrosion protection conform to the requirements given in 4.1.7.1.

The effect of galvanic corrosion shall be considered by checking the design of the expansion joint (reference 8.3).

5.1.7.1.2 Chemicals

The assessment shall be based on common knowledge and/or experience which can be demonstrated with reference to EN, ISO and/or national standards, national approvals of expansion joint or similar material/component.

Alternatively, the assessment shall be based on testing (laboratory or field).

The accidental condition shall not be taken into account.

Note: For de-icing salts see also 5.1.7.1.4 below.

5.1.7.1.3 Ageing resulting from UV radiation, temperature and ozone

Materials may be susceptible to UV radiation, temperature, and ozone degradation. Where relevant, take into consideration:

a) Temperature

To check the sensitivity of the elastomer or plastic to elevated temperature, the material shall be subjected to test method ISO 188 (Method A) for elastomer or EN ISO 11403-3 (6.5, exposure to heat condition) for plastic. The minimal conditions of exposure are the following: 14 days at a temperature of 70 °C (temperature and time shall be defined depending on the elastomer composition, see ISO 471). The hardness is measured according to ISO 7619, the tensile strength and the elongation at rupture are measured according to ISO 37.

b) UV ray

Where polymeric material (e.g. polyurethane, epoxy) is exposed to UV-rays and its material property might be affected, a test shall be carried out. The test specimen shall be exposed to UV Radiation according to the procedure of EOTA Technical Report 010 with the use of fluorescent tubes (UV-A) after 5 000 hours exposure.

c) Ozone

To check the sensitivity of elastomer or plastic to ozone, the material shall undergo a test. The test specimen shall be verified according to test method ISO 1431-1 (Test procedure A: static condition). The test conditions are the following: 74 hours of exposure at the temperature of 40 °C, with an ozone concentration of 50 pphm. The test specimen is submitted to 20 % of elongation. If these test conditions are not applicable, alternative test conditions shall be used and defined in the concerned family Part.

The test conditions used shall be stated in the evaluation report.

5.1.7.1.4 - Resistance against freeze-thaw

The degradation of porous materials (e.g. mortar), to freeze-thaw shall be checked by testing. Test specimen(s) of the material or component shall be subjected to freeze/thaw cycles in accordance with EN 13687-1. According to the use of the product, the number of cycles shall be 50 (see EN 1504-2, Tables 5, line 9 and Table 1, 1.3 and 5.1).

5.1.7.2 Aspects of serviceability

The information for the installation, inspection and maintenance, given by the manufacturer, shall be checked by the Approval Body to prove that the assembled joint can be installed, inspected and maintained.

5.1.7.3 Aspects of identification

Verification of certificates, test reports and labelling.

5.2 COMPONENTS

A non exhaustive list of verification methods is stated in the relevant family Part.

The manufacturer shall indicate the verification methods (certificate, test method, ...). Where no appropriate EN or ISO standard is available, the use of national provisions is permitted.

6. ASSESSING AND JUDGING THE FITNESS OF PRODUCTS FOR AN INTENDED USE

This chapter details the performance requirements to be met (Chapter 4) in precise and measurable (as far as possible and proportional to the importance of the risk) or qualitative terms, related to the expansion joint and its intended use, using the outcome of the verification methods (Chapter 5).

6.0 TABLE LINKING THE ESSENTIAL REQUIREMENTS TO PRODUCT REQUIREMENTS

ER	Characteristics specified in the mandate	ETAG paragraph on product performance to be assessed	Class, use category, criterion		No performance determined option
1	Mechanical resistance	§ 6.1.1.2	Carriageway	Pass/fail	No
			and/or Footpath	Pass/fail	No
			and/or options: - accidental load on footway	Pass/fail	No
			- collision on kerb	Pass/fail	No
	Resistance to fatigue	§ 6.1.1.3	Pass/fail		No
	Seismic behaviour	§ 6.1.1.4	Declaration of selected approach and relevant information (aspects etc.)		Yes
	Movement capacity	§ 6.1.1.5	Declared values		No
	Cleanability	§ 6.1.1.6	Pass/fail		Yes
Resistance to wear	§ 6.1.1.7	See relevant family Part		No	
Watertightness	§ 6.1.1.8	Pass/fail		Yes	
2	Not relevant				
3	Release of dangerous substances	§ 6.1.3	Indication of dangerous substances incl. concentration, etc. or "No dangerous substances"		Yes
4	Allowable surface gaps and voids.	§ 6.1.4.1.1	Gap/voids		
			For vehicle	Pass/fail	Yes
			Gap for use in longitudinal axis	Pass/fail	Yes
			Gap/voids/recess		
			- For cyclist	Pass/fail	Yes
	- For pedestrian	Pass/fail	Yes		
	Level differences in the running surface	§ 6.1.4.1.2	Level differences and steps	Pass/fail	Yes
			For other related or additional requirements defined in the family Parts if relevant	Pass/fail or declared value, see family Part	Yes
	Skid resistance	§ 6.1.4.2	On carriageway	Pass/fail or declared value	Yes
On footpath			Pass/fail or declared value	Yes	
Drainage capacity	§ 6.1.4.3	Declared value		Yes	
5	Not relevant				
6	Not relevant				

7	Durability of the characteristics against: Corrosion, ageing, chemicals, temperature, UV-radiation, freeze-thaw, ozone	§ 6.1.7.1	Corrosion	Pass/fail (considering the working life category)	No
			Chemicals	Pass/fail	No
			Ageing resulting from		
			- temperature	Pass/fail	No
			- UV radiation,	Pass/fail	No
			- ozone	Pass/fail	No
			Resistance against freeze-thaw	Pass/fail	No

6.1 KITS

6.1.1 Mechanical resistance and stability

6.1.1.1 General

6.1.1.2 Mechanical resistance

The expansion joint will be judged as fit for purpose for the designated use categories given in 2.2.1, provided that it satisfies the performance requirements in 4.1.1.2 by the verification procedure as described in 5.1.1.2.

6.1.1.3 Resistance to fatigue

The expansion joint will be judged as fit for purpose provided that it satisfies the performance requirements in 4.1.1.3 by means of passing the verification procedure as described in 5.1.1.3.

6.1.1.4 Seismic behaviour

The selected approach in accordance with 4.1.1.4 and the relevant indications as in Table 4.1.1.4 shall be declared and stated in the ETA. The verification shall be in accordance with 5.1.1.4.

6.1.1.5 Movement capacity

The results of the verification of the declared value according to the verification method given in 5.1.1.5, for the concerned directions shall be stated in the ETA, see movement capacity definition. The reaction forces shall be stated in the ETA. The minimum opening shall be stated in the ETA.

6.1.1.6 Cleanability

The expansion joint will be judged as fit for purpose provided that it satisfies the performance requirements in 4.1.1.6 by means of passing the verification procedure as described in 5.1.1.6.

6.1.1.7 Resistance to wear

See relevant family Part.

6.1.1.8 Watertightness

The assessment of whether the assembled kit remains watertight, shall be undertaken according to the verification method given in 5.1.1.8.

If watertightness is achieved by sub-surface drainage system this shall be addressed, including assessment of passage of water and durability of the material of the drainage system.

If the Expansion Joint includes a connection between the joint and the waterproofing of the main structure, this connection shall be assessed with a pass/fail criterion.

6.1.2 Safety in case of fire

Not relevant.

6.1.3 Hygiene, health and environment (ER 3)

6.1.3.1 Release of dangerous substances

The expansion joint shall comply with all relevant European and national provisions applicable for the uses for which it is brought to the market. The attention of the applicant shall be drawn on the fact that for other uses or other Member States of destination there may be other requirements which would have to be respected. For dangerous substances contained in the expansion joint, the NPD option (no performance determined) is applicable.

Agreed, we have added in paragraph 6.1.3. " The expansion joint and/or constituents of the expansion joint listed in the EOTA TR 034: "General Checklist for ETAGs/CUAPs/ETAs -Content and/or release of dangerous substances in products/kits", which have to be considered will be verified by the given methods taking into account the installation conditions of the construction product and the release scenarios resulting from there. Regulations related to placing the product on the market may also need to be taken into account.

Regarding the release scenarios referred to in the EOTA TR 034, the use category S/W2 (Product with no direct contact to but possible impact on soil, ground and surface water have to be considered."

Other paragraph concerning dangerous substances have not been modified.

6.1.4 Safety in use

6.1.4.1 Ability to bridge gaps and levels in the running surface

6.1.4.1.1 Allowable surface gaps and voids

The expansion joint will be judged as fit for purpose provided that it satisfies the performance requirements in 4.1.4.1.1 by means of passing the verification procedure as described in 5.1.4.1.1.

The ETA shall state the maximum angle β (relative to the traffic direction) related to the concerned user category.

6.1.4.1.2 Level differences in the running surface

Assessment for the unloaded condition shall be undertaken on the basis of analysis of the technical file and drawings. The maximum dimension of steps and the difference of the running surface levels shall be stated in the ETA.

For other or additional requirements, see the family Part if relevant.

6.1.4.2 Skid resistance

Assessment shall be undertaken on the basis of analysis of the design. If required, the result according to the verification method given in 5.1.4.2 shall be stated in the ETA.

6.1.4.3 Drainage capacity

Assessment shall be undertaken according to 5.1.4.3.

6.1.5 Protection against noise

Not relevant.

6.1.6 Energy economy and heat retention

Not relevant.

6.1.7 Aspects of durability, serviceability and identification of the products

6.1.7.1 Aspects of durability

6.1.7.1.1 Corrosion

Assessment shall be undertaken on the basis of analysis of the Technical File according to 5.1.7.1.1.

The corrosion protection system and, in case of aluminium alloy the concerned category shall be declared, including the relevant atmospheric corrosivity category and durability range and shall be followed by the information, that the provision regarding the durability range, made in the European Technical Approval, is not a “guarantee time”.

Note: The holder of the ETA may indicate in his technical documentation whether additional measures are intended due to wear of the coating of the trafficked surfaces.

The ETA shall include relevant information (e.g. drawing) regarding the execution of metallic surfaces in contact with concrete.

6.1.7.1.2 Chemicals

Assessment shall be undertaken on the basis of 5.1.7.1.2.

6.1.7.1.3 Ageing resulting from temperature, UV radiation and ozone

For components or materials which are susceptible to UV radiation, temperature, and ozone degradation, the following shall apply.

a) Ageing resulting from temperature

The assessment shall be undertaken according to the verification method given in 5.1.7.1.3a. After the test, the change in hardness and in tensile properties shall fulfill the requirements given in the relevant family Part.

b) Ageing resulting from UV ray

The assessment shall be undertaken according to the verification method given in 5.1.7.1.3b. After the test, the change in tensile properties shall fulfill the requirements given in the relevant family Part.

b) Ageing resulting from ozone

The assessment shall be undertaken according to the verification method given in 5.1.7.1.3c. After the test, no micro cracks shall be observed.

6.1.7.1.4 Resistance against freeze-thaw

The assessment shall be undertaken according to the verification method given in 5.1.7.1.4. After the test, no degradation shall be observed.

6.1.7.2 Aspects of serviceability

The assessment shall be undertaken according to 5.1.7.2.

6.1.7.3 Aspects of identification

The assessment shall be undertaken according to the 5.1.7.3.

6.2 COMPONENTS

Identification of the characteristics of the components of a Road Bridge Expansion Joint shall be as defined in Parts 2 to 8 of this ETA Guideline relevant to the specific family of products.

The Approval Body shall assess the possible effects on the performance of the expansion joint due to the variability of the sub-components and materials characteristics and, where applicable, declared tolerances.

7. ASSUMPTIONS AND RECOMMENDATIONS UNDER WHICH THE FITNESS FOR USE OF THE PRODUCTS IS ASSESSED

7.0 GENERAL

This chapter sets out the assumptions and recommendations for design, installation and execution, packaging, transport and storage, use, maintenance and repair under which the assessment of the fitness for use according to the Guideline can be made (only when necessary and in so far as they have a bearing on the assessment or on the products).

Successful application of a road bridge expansion joint is only obtained when approved expansion joints are installed by competent personnel.

The manufacturer is assumed to submit in the Manufacturer Technical Dossier (MTD) information concerning the subjects covered in 7.1 to 7.4. It shall be assessed by the Approval Body.

7.1 DESIGN OF WORKS

(Including, if necessary, indications on project testing)

The basis for quality of a road bridge expansion joint lies in the design which evolves from good co-ordination between all parties involved. The most important role is that of the designer of the main structure who has, initially, to prepare a preliminary design, as general as possible and suitable for any road bridge expansion joint. A good design gives due consideration to detailing. This is very much related to the technologies to be implemented by the road bridge expansion joint specialist companies. Such companies consist of qualified personnel who are thoroughly familiar with the possibilities or alternatives and limits of road bridge expansion joints. Since it is fundamental that a close technical consultation is set up between these major participants before design completion, the manufacturer is assumed to be able to advise and propose appropriate road bridge expansion joint design and detailing.

The quality of a road bridge expansion joint is also bound to the quality of the works performance. With consideration to the high technology involved in the use of the road bridge expansion joint technique, as well as to the safety implications, it is assumed that the kit is installed by such road bridge expansion joint competent personnel.

In order to consider an installation in the works ensures that the expansion joint will have been implemented in conformity with the ETA, the manufacturer shall provide the designer of the works with the following minimum information:

- list of information given in the ETA and applicable to the specific works (movement capacity, users category, actions category, working life and related traffic category in accordance with EN 1991-2, Table 4.5, allowable range of ambient temperature, ...),
- forces to be transmitted from the joint to the main structure. Special attention shall be paid to the connecting reinforcement,
- nominal dimensions to respect in the abutment or in this part of the structure in order to allow a correct placement of the RBEJ, in particular the distance between the parts of the structure,
- ambient conditions (temperature and/or humidity) for correct installation.
- conditions of levelling (height shift, change in slope, etc.) to the adjacent surface of the joint (e.g. safety in use for comfort),
- capability of the system in skew angle situations,
- provisions for the connection to the bridge waterproofing and/or drainage,
- minimum grade of concrete in the connection area,
- allowable deformation of the adjacent structure,
- allowable location of butt joints of the Expansion Joint on site.

For the reasons presented above the road bridge expansion joint description presented to the Approval Body is assumed to include road bridge expansion joint design, materials, components, equipment, installation procedures, workmanship and methods of supervision.

7.2 PACKAGING, TRANSPORT AND STORAGE

7.2.1 Packaging

The manufacturer is assumed to have instructions related to temporary protection of the expansion joint and its components in order to prevent corrosion, mechanical, chemical or electrochemical damage during transportation and during storage period.

7.2.2 Transport and storage

For components which are sensitive to temperature and condition of storage (e.g. resin, primer and glue), storage temperature, way of storage (tanks, drums) for these components, the instructions are assumed to contain the necessary information on conditions for transport and storage. Where kits incorporate chemicals, flammable components or other potentially hazardous materials, the instructions are assumed to contain specific guidance on restrictions and/or conditions for handling, transport and storage of these components.

7.3 EXECUTION OF WORKS

The road bridge expansion joint manufacturer is assumed to be able to:

- give guidance on how to prepare and to execute the work on sites with consistent quality,
- train and qualify personnel.

The installation and connection to the bridge deck and, if required, its waterproofing connection is assumed to ensure that it meets the national requirements on bridge waterproofing. The conditions of installation are assumed to give a guarantee of correct levelling of the joint with the level of adjacent bridge pavement.

A manual for the installation of the kit in the works shall be available from the manufacturer, and shall be assessed by the Approval Body. This manual is part of the MTD.

The conditions for design and installation of the joint into the works shall be taken from the manufacturer's installation manual. The manual shall cover all important aspects related to the site work, such as:

- Preliminary Operations (e.g. checking of the material, traffic safety measures, ...),
- Check that the RBEJ corresponds to the planned location or installation, and check:
 - dimensions,
 - connection reinforcement (if applicable).
- Installation of the RBEJ:
 - cut out of the surfacing and the waterproofing (where relevant),
 - preparation of the structure recess,
 - installation of drain and connection to the bridge waterproofing,
 - additional reinforcements,
 - installation of the temporary fixings system,
 - minimum concrete quality in the connection area,
 - installation of the road bridge expansion joint,
 - instructions for the connections to the main structures,
 - instructions for the presetting and adjustment of it,
 - information about a minimum opening position to be considered,
 - preliminary control before pouring of the concrete.
- Instructions to repair the corrosion protection damaged during transport and installation]
- Final checking of the expansion joint
- Factory control documents

Where the kits involve the use of chemicals and other potentially hazardous materials, the installation manual is assumed to give precise information on their safe disposal and packaging used to supply them in accordance with national regulations, if applicable.

Where the kits incorporate flammable or hazardous components, the installation guide is assumed to give precise information to allow safe use and application.

For optimal self cleaning of gutter/seal, an adequate slope in the joint direction is assumed to be included as part of the bridge design, and recommended in the ETA.

7.4. MAINTENANCE AND REPAIR

Guidelines for periodic inspection, maintenance and repair, and specific measures related to maintenance (e.g. replacement of components) shall be part of the Manufacturer's Technical Dossier.

It is assumed that regular maintenance is required to retain performance and to obtain the working life of the expansion joint. The type and frequency of such maintenance shall be specified, and shall be part of the assessment of the kit.

Section three: ATTESTATION OF CONFORMITY (AoC)

8. ATTESTATION AND EVALUATION OF CONFORMITY

8.1 EC DECISION

The system of attestation of conformity according to the Decision 2001/19/EC dated 2000/12/20 is system 1 described in Council Directive (89/106/EEC) Annex III 2 i) and is detailed as follows:

(a) tasks for the manufacturer

- (1) Factory production control,
- (2) Further testing of samples taken at the factory by the manufacturer in accordance with a prescribed test plan;

(b) tasks for the Approved Body

- (3) Initial type-testing of the product,
- (4) Initial inspection of factory and of factory production control,
- (5) Continuous surveillance, assessment and approval of factory production control.

8.2 RESPONSIBILITIES

8.2.1 Tasks for the manufacturer

8.2.1.1 Factory production control (FPC)

8.2.1.1.1 General responsibilities of the manufacturer

The manufacturer shall exercise permanent internal control of production. All the elements, requirements and provisions adopted by the manufacturer shall be documented in a systematic manner in the form of written policies and procedures. This production control system shall ensure that the expansion joint is in conformity with the European Technical Approval (ETA).

Manufacturers having an FPC system which complies with EN ISO 9001 and/or EN ISO 9002 **and** which addresses the requirements of an ETA are recognised as satisfying the FPC requirements of the Directive.

EC Guidance Paper B [7] provides for a common basis of understanding factory production control.

The kit manufacturer shall keep available an updated list of all suppliers. Copies of this list shall be made available to the CB¹ and may be made available to the Approval Body for information.

The frequency of control shall be derived from the execution class 3 for load bearing steel sub-components and class 2 for non load bearing sub-component, according to EN 1090-2.

8.2.1.1.2 Control of incoming products and materials

The incoming materials and products should comply with a harmonized technical specification, the corresponding AoC procedure and the specified inspection certificate in accordance with EN 10204, where applicable. Additional checks may be necessary when there are additional requirements due to their use in an expansion joint.

¹ CB: Certification Body.

The incoming materials and products may also comply with other equivalent valid specifications provided that their use is compatible with the results of the approval tests. Then the specifications shall be given in the ETA.

The manufacturer shall perform suitable incoming tests, specific instructions are given in family Parts. All products and materials shall be in accordance with the requirements of the ETA and the corresponding specifications of the kit manufacturer.

8.2.1.1.3 Inspection and testing during production

The validity of the type and frequency of checks/tests conducted during production shall be considered as a function of the production process. This will include the checks conducted during manufacture on properties that cannot be inspected at a later stage and partly for checks on the final expansion joint. These may include:

- definition of the number of samples taken by the kit manufacturer,
- material properties e.g. tensile strength, hardness, surface finish or chemical composition,
- determination of the dimensions of components,
- checking correct assembly,
- personnel qualification (e.g. welding, corrosion protection),
- control measurements of the production process,
- documentation of tests and test results.

All tests and control measurements shall be performed according to written procedures (test plan) with suitable calibrated measuring devices. All test results shall be recorded in a consequent and systematic way.

Both large and small companies produce these products and there is a wide variation in the materials used and the production processes. Therefore a precise test plan can only be set up on a case-by-case basis.

Indirect methods are also sufficient, e.g. control of raw materials, manufacturing processes and properties of components if the correlations to characteristics which are important for the performance of the kit are given.

In the family Parts basic test plans (amount and type of tests and minimum frequencies) are given. This shall be the basis of specified test plan in the ETA².

8.2.1.1.4 Control of non-conformity

The quality manual has to address control of non-conforming products.

8.2.1.1.5 Complaints

The quality manual shall include provisions to keep records of all complaints about the components and materials for at least five (5) years.

² "According to frequency" and "sampling regime" could be based on experience or custom and practice in a given product sector or statistical methods.

8.2.1.2 Testing of samples taken at the factory – Prescribed Test Plan

Further test of samples taken at the factory by the manufacturer may be conducted in accordance with a prescribed test plan, i.e. if not covered by the FPC system.

Both large and small companies produce these products and there is a wide variation in the materials used. Therefore a precise prescribed test plan can only be set up on case-by-case basis. In the family Parts basic prescribed test plans (amount and type of tests and minimum frequencies) are given. This shall be the basis of the specified prescribed test plan in the ETA.

In general it is not necessary to conduct tests on kits (or assembled systems) but on the characteristics and/or properties of components.

8.2.2 Tasks of the Approved Body

8.2.2.1 General

The CB may act with its own resources or subcontract inspection tasks and testing tasks to inspection bodies and testing laboratories that meet the requirements of the Guidance Paper "A" [6].

The ITT and the assessment of the FPC based on initial inspection and continuous surveillance shall be included in the control plan. The tasks and their frequency shall be given in the control plan and will depend on the nature of the product. This is defined in the family Parts.

8.2.2.2 Initial Type-Testing

Approval tests will have been conducted by the Approval Body or under its responsibility (which may include a proportion conducted by an indicated laboratory or by the manufacturer, witnessed by the Approval Body) in accordance with Chapter 5 of this ETAG. The Approval Body will have assessed the results of these tests in accordance with Chapter 6 of this ETAG, as part of the ETA issuing procedure.

These test results should be used for the purposes of Initial Type-Testing.

If approval tests were made on prototypes or in case of changes in the production line or plant or of component(s), there may be a need for a new ITT (see also Chapter 9).

8.2.2.3 Assessment of the factory production control system. Initial inspection and continuous surveillance

Assessment of the factory production control system is the responsibility of the Approved Body.

An assessment shall be carried out of each production unit to demonstrate that the factory production control is in conformity with the ETA and any supplementary information (control plan). This assessment shall be based on an initial inspection of the factory.

Subsequently continuous surveillance of factory production control is necessary to ensure continuing conformity with the ETA. Detailed instruction on the frequency of surveillance is given in the family Parts.

Surveillance inspections shall be conducted ***at least once a year.***

8.2.2.4 Certification

The Approved Body shall issue a Certification of Conformity of the expansion joint.

8.3 DOCUMENTATION

The Approval Body issuing the ETA shall ensure that the manufacturer supplies the information detailed below. The information given below together with the requirements given in EC Guidance Paper B [7] will generally form the basis on which the factory production control (FPC) is assessed.

This information shall initially be prepared or collected by the Approval Body and shall be agreed with the manufacturer. The following gives guidance on the type of information required:

(1) The ETA

See Section four of this Guideline.

Where the assessment of the joint depends in part on confidential information, such information shall be included in the Manufacturer's Technical Dossier. The ETA shall refer to this MTD. However, such information shall not form part of the ETA.

(2) Basic manufacturing process

The basic manufacturing process shall be described in sufficient detail to support the proposed FPC methods.

(3) Product and material specifications

These shall include, when necessary to assess the performance of the expansion joint:

- detailed drawings (including manufacturing tolerances),
- incoming (raw) materials specifications and declarations,
- references to European and/or international standards or appropriate specifications,
- manufacturer's data sheets.

(4) Test plan (as part of FPC)

The manufacturer and the Approval Body issuing the ETA shall agree an FPC test plan.

An agreed FPC test plan is necessary as current specifications relating to quality management systems (Guidance Paper B, EN ISO 9001, etc.), do not ensure that the product specification remains unchanged and they cannot address the technical validity of the type or frequency of checks/tests.

The validity of the type and frequency of checks/tests conducted during production and on the final product shall be considered. This will include the checks conducted during manufacture on properties that cannot be inspected at a later stage and checks on the final product. These will normally include a frequency of routine tests according to tables given in each family Part.

These tests need not necessarily be carried out in accordance with test methods described in the Guideline.

Where materials/components are not manufactured and tested by the supplier in accordance with agreed methods, then where appropriate they shall be subject to suitable checks/tests by the manufacturer before acceptance.

(5) Prescribed test plan

The manufacturer and the Approval Body issuing the ETA shall agree a prescribed test plan.

Cornerstones are given in family Parts.

8.4 CE MARKING AND ACCOMPANYING INFORMATION

According to Council Directive 93/68/EEC the CE Marking consists of the letters “CE” followed by the identification number of the notified certification body.

The ETA shall indicate the information to accompany the CE marking.

In accordance with Guidance Paper D the required information to accompany the symbol “CE” is:

- name/address or identifying mark of the producer,
- last two digits of the year in which the CE marking was affixed,
- number of the EC certificate of conformity,
- number of the ETA,
- reference to the concerned Part of this ETA Guideline.

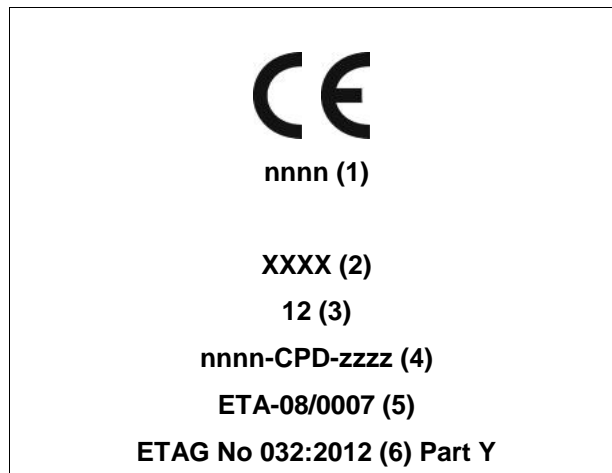

- (1) Identification number of the notified body involved in the attestation of conformity (certification body),
- (2) Name/address or the identifying mark of the producer,
- (3) Last two digits of the year in which the CE marking was affixed,
- (4) Number of the EC certificate of conformity (consisting of number of notified body involved in the AoC (“nnnn”) – CPD – number of EC certificate of conformity (“zzzz”)),
- (5) Number of the European Technical Approval,
- (6) ETAG number including date of publication.

The CE marking shall be affixed according to Guidance Paper D, 3.2.

The following accompanying information on the product separate to the CE marking shall be given by the manufacturer:

- date of manufacture,
- identification number of the product.

Section four: ETA CONTENT

9. THE ETA CONTENT

All the technical data necessary for design and execution shall be submitted by the applicant with the application and will be used by the Approval Body to create the ETA and to define the additional information.

Clauses 9.1 and 9.2 distinguish between information:

- given in the ETA,
- available additional information given to anyone concerned in design and execution such as design engineers, contractors, clients and authorities, as needed.

In general both sets of information shall not contain any confidential information. Confidential information may be dimensional tolerances, manufacturing processes, composition of components, etc.

9.1 THE ETA-CONTENT

9.1.1 Model ETA

The format of the ETA shall be based on the Commission Decision (97/571/EC) (ETA-format) of 22.07.1997, EC Official Journal L236 of 1997-08-27.

9.1.2 Checklist for the Approval Body

The technical part of the ETA shall contain information on the following items, in the order and with reference to the relevant Essential Requirements (ER 1, 3 and 4). For each of the listed items, the ETA shall either give the mentioned indication/classification/statement/description or state that the verification/assessment of this item has not been carried out (no performance determined). The items are here given with reference to the relevant paragraphs of this ETAG, whereas specific use categories may require descriptions of additional measures and/or optional devices:

- 1) Definition and description of the type of the kit (product family) and the range of product for which an ETA is issued. This shall include a listing and description of all components of the kit, for which the ETA is issued.
- 2) Intended use
 - Use categories,
 - Actions categories,
 - Working life (indication of the assumed working life, 2.3.4, and any need for maintenance to achieve it),
 - Range of ambient temperatures, 2.3.2, for which the proper functioning of the expansion joint is verified.

3) Characteristics of product(s) and methods of verification

a) Characteristics of product(s)

ER1 Mechanical resistance and stability

Mechanical resistance* (requested information on anchor forces for load distribution to the adjacent parts)
Resistance to fatigue*
Seismic behaviour*
Movement capacity (including reaction forces)
Cleanability
Resistance to wear
Watertightness

* The load models, adjustment factors, load factors and combination factors are stated in method of verification.

ER3 Hygiene, health and environment

Indicate by means of a declaration of the manufacturer if the kit or the used materials contain any or no dangerous substances and, if so, which ones.

Insert both the following model clauses:

- "Release of dangerous substances

The ETA is issued for the kit with the chemical composition and other characteristics of its construction products deposited with the [the Approval Body name]. The Approval Body shall be immediately notified of changes of materials, composition or characteristics. It then decides whether a new assessment is necessary."

- "In addition to the specific clauses relating to dangerous substances contained in this European Technical Approval, there may be other requirements applicable to the products falling within its scope (e.g. transposed European legislation and national laws, regulations and administrative provisions). In order to meet the provisions of the Construction Products Directive, these requirements need also to be complied with, when and where they apply."

ER4 Safety in use

Allowable surface gaps and voids (restrictions related to the crossing angle in the traffic direction shall be declared)
Levels in the running surface
Skid resistance
Drainage capacity

Aspects of durability, serviceability and identification

- **Durability**

The durability in relation to corrosion, chemicals and ageing shall be stated. The corrosion protection system for components, if any, shall be described (see table of components) including the measures for maintenance.

- **Serviceability**

The assessment (where required by this ETAG and/or where declared by the manufacturer) on the effects on the performance of the product due to the declared limits of site conditions during installation shall be stated.

- **Identification**

Insert the following paragraph: "The ETA is issued for the product/kit on the basis of agreed data/information, deposited with {the Approval Body name}, which identifies the product/kit that has been assessed and judged. Changes to the product/production process/kit, which could result in this deposited data/information being incorrect, shall be notified to the {the Approval Body name} before the changes are introduced. The {Approval body name} will decide whether or not such changes affect the ETA and consequently the validity of the CE marking on the basis of the ETA and if so whether further assessment/alterations to the ETA, shall be necessary."

For components, insert the following paragraph: "The kit comprises components which are factory-made by the ETA-holder and/or the component suppliers. The ETA-holder is ultimately responsible for the kit."

List all components and address the following aspects:

- Designation of each component
- Materials by referring to standards (with relevant certificate, if needed), trade names, specific requirements, as relevant
- Description and drawings for all components. Dimensions as required especially for identification of the component, design of the works, especially critical dimensions relevant to the installation of the system, minimum length of thread engagement, etc. as relevant
- Etc. as relevant

b) Methods of verification

Insert the following paragraph: "The assessment of the fitness of the product/kit for the intended use has been made in compliance with the Guideline for European Technical Approval of "Expansion joints for road bridges", ETAG 032, Part 1: "General", in conjunction with ETAG 032, Part Y."

For mechanical resistance, resistance to fatigue and seismic behaviour the following principles shall be addressed:

- The load models used (LM1_{EJ}, FLM1_{EJ} or FLM2_{EJ} of the general Part of this ETAG),
- Adjustment factors (α),
- Load factors (γ),
- and Combination factors (ψ).

For components, verification results shall be presented in a table.

4) Evaluation of Conformity and CE marking

- The Attestation of conformity system, referred to Chapter 8, 8.1.
- Responsibilities

- **Tasks of the manufacturer**

Factory production control

Indicate the FPC control plan (including the aspects for components) with type and minimum frequency of tests.

Testing of samples taken at the factory

Insert type and minimum frequency of tests where relevant.

Other tasks of manufacturer

Insert the following paragraph:

"The manufacturer of the product makes available concerned additional confidential information to the certification body for the evaluation."

Tasks of Approved Bodies

Initial type-testing of the product

Insert the following paragraph: "For ITT, the results of the tests performed as part of the assessment for the ETA may be used unless there are changes in the product, production line or plant, where these changes have the effect of invalidating the results of one or more of the approval tests. In such cases the necessity for new approval tests and/or ITT has to be agreed between the {Approval Body and Certification body name}, and the manufacturer involved."

Initial inspection of factory and factory production control

Insert the following paragraph: "The Approved Body shall ascertain that in accordance with the prescribed test plan, the precautions in the factory, in particular the staff and the equipment concerning, and the FPC are suitable to ensure a continuous and orderly manufacturing of the kit/product with the specifications mentioned in the relevant sections."

Continuous surveillance, assessment and approval of factory production control

Insert the following paragraph: "The Approved Body shall visit the factory at least one (1) time per year for surveillance. It shall be verified that the system of FPC and the specified manufacturing process are maintained taking into account the prescribed control plan."

The results of product certification and continuous surveillance shall be made available on demand by the Approved Body to the {Approval Body name}.

In cases where the provisions of the ETA and the prescribed control plan are no longer fulfilled the certificate of conformity shall be withdrawn and the {Approval Body name} shall be informed immediately.

9.2 ADDITIONAL INFORMATION

It shall be stated in the ETA, that the ETA holder is responsible to inform anyone concerned about the use of the RBEJ system. Additional information shall be held available at the ETA holder and shall be distributed as needed.

The ETA shall also include other information related to movement capacity (e.g. maximum gap or overlap of fingers) where relevant to the design of the joint and/or where required by national regulations.

It shall be stated in the ETA, that additional (possibly confidential) information shall be supplied to the Certification Body for the evaluation of conformity, see 8.3(1) of this ETAG.

9.3 CONFIDENTIAL INFORMATION

Copies of manufacturing drawings, specifications and installation manual of the RBEJ system and components in sufficient detail to define manufacturing (e.g. chemical composition of materials not defined in standards) need to be deposited at the Approval Body and Certification Body. These documents are restricted or confidential and proprietary and shall not be given to other parties without authorisation from the manufacturer.

The ETA shall contain, taking into account the need of confidentiality, sufficient detailed information as to identify without ambiguity the product in case of complaints or accidents.

When such information/references are of a confidential nature it/they shall exist on the ETA file managed by the Approval Body and as necessary on the relevant file of the notified product certification body involved.

This/these information/references shall also be of assistance in any renewal of the ETA.

The type, scale, range of information will be based on the identification clauses in Chapter 5 of the ETAG.

9.4 INSTALLATION REQUIREMENTS

Additional installation aspects other than those listed in 9.1 may need to be provided:

- Use with skew bridges,
- Connecting with the waterproofing system of the bridge,
- Anchorage with the structure of the bridge,
- Etc. (e.g. correct levelling of the adjacent parts) as relevant.

This chapter sets out assumptions and recommendations for packaging, transport and storage, installation, maintenance and repair under which the assessment of the fitness for use according to the Guideline can be made.

"Successful application of a road bridge expansion joint is only obtained when the approved expansion joint are installed by competent personnel."³

The installation manual forms part of the ETA and it shall be available to the installer.

Note for users and owners: noise generation on a joint is a point which may be verified in the design and the construction of the works.

³ Clause coming from the 2nd part of 7.0.

ANNEXES TO THE ETAG

Annex A: Common terminology (to be taken over in every ETAG).

Annex B: Assumption of working life of construction products (EOTA Guidance document 002).

Annex C: Assessment of the working life of products (EOTA Guidance document 003).

Annex D: The provision of data for assessment leading to ETA (EOTA Guidance Document 004).

Annex E: Editorial aspects of ETAGs (EOTA Guidance Document 005).

Annex F: Reference material for ETAGs, Comprehension Documents for ETAGs, Updating process of ETAGs.

Annex G: Traffic loads and combinations.

Annex H: Number of products to be tested.

Annex J: Seismic approach – design philosophy for RBEJ.

Annex K: Movement capacity test method.

Annex L: Watertightness test method.

Annex A
COMMON TERMINOLOGY
(definitions, clarifications, abbreviations)

See Document "Common Terms used in Guidelines for ETAs" available on the EOTA website www.eota.be, Section "Endorsed ETAGs".

Annex B
ASSUMPTION OF WORKING LIFE OF CONSTRUCTION
PRODUCTS (EOTA GUIDANCE DOCUMENT 002)

Annex C
ASSESSMENT OF THE WORKING LIFE OF PRODUCTS (EOTA
GUIDANCE DOCUMENT 003)

Annex D
THE PROVISION OF DATA FOR ASSESSMENT LEADING TO
ETA (EOTA GUIDANCE DOCUMENT 004)

Annex E
EDITORIAL ASPECTS OF ETAGS (EOTA GUIDANCE
DOCUMENT 005)

Annex F
REFERENCE MATERIAL FOR ETAGS, COMPREHENSION
DOCUMENTS FOR ETAGS, UPDATING PROCESS OF ETAGS

Annex G

TRAFFIC LOADS AND COMBINATIONS

G.1 – GENERAL

This annex describes the traffic loads, load combinations and how to deal with internal forces in conjunction with the geometry of the expansion joint in order to verify the mechanical resistance.

This annex gives the detailing of the traffic loads on expansion joints that for (quasi-) static verification at Ultimate Limit State and where requested in the relevant family Parts at Serviceability Limit State shall be used in combination with prestress, imposed deformations, dead loads and seismic loads, where relevant.

In addition, guidance is given for fatigue loads.

These loads are based on the loads given in EUROCODES, principally EN 1991-2. Where necessary, further details and load distribution coefficients are given in family Parts 2 to 8.

For issuing ETAs, the values of the coefficients α , γ and Ψ are given in this Annex G.

The wheel load is distributed on the effective contact areas between the wheel and the surface sub-components, including the kerb units, assuming a rigid behaviour of the tyre contact surface.

The load introduction shall consider the detailing of the contact area according to the zones given below, whereas the Figure G1 does not show necessarily the most adverse position of the wheel print.

Zone 1: Area of the print on the surface of the adjacent pavement,

Zone 2: Area of the print on the surface of the transition strip,

Zone 3: Area where the tyre is fully in contact with the expansion joint sub-component A' according to Figure G1,

Zone 4: Area where the tyre is fully in contact with the expansion joint sub-component A'' according to Figure G1,

Zones 5' and 5'': Areas where the tyre is not supported by the expansion joint (areas of gaps and voids).

This principle applies for vertical forces (contact pressures) and horizontal forces.

The static resistance of the joint is verified at the most adverse opening. For each section or part to be verified the most adverse position of the loads shall be identified by means of influence lines/surfaces in conjunction with the zoning principles.

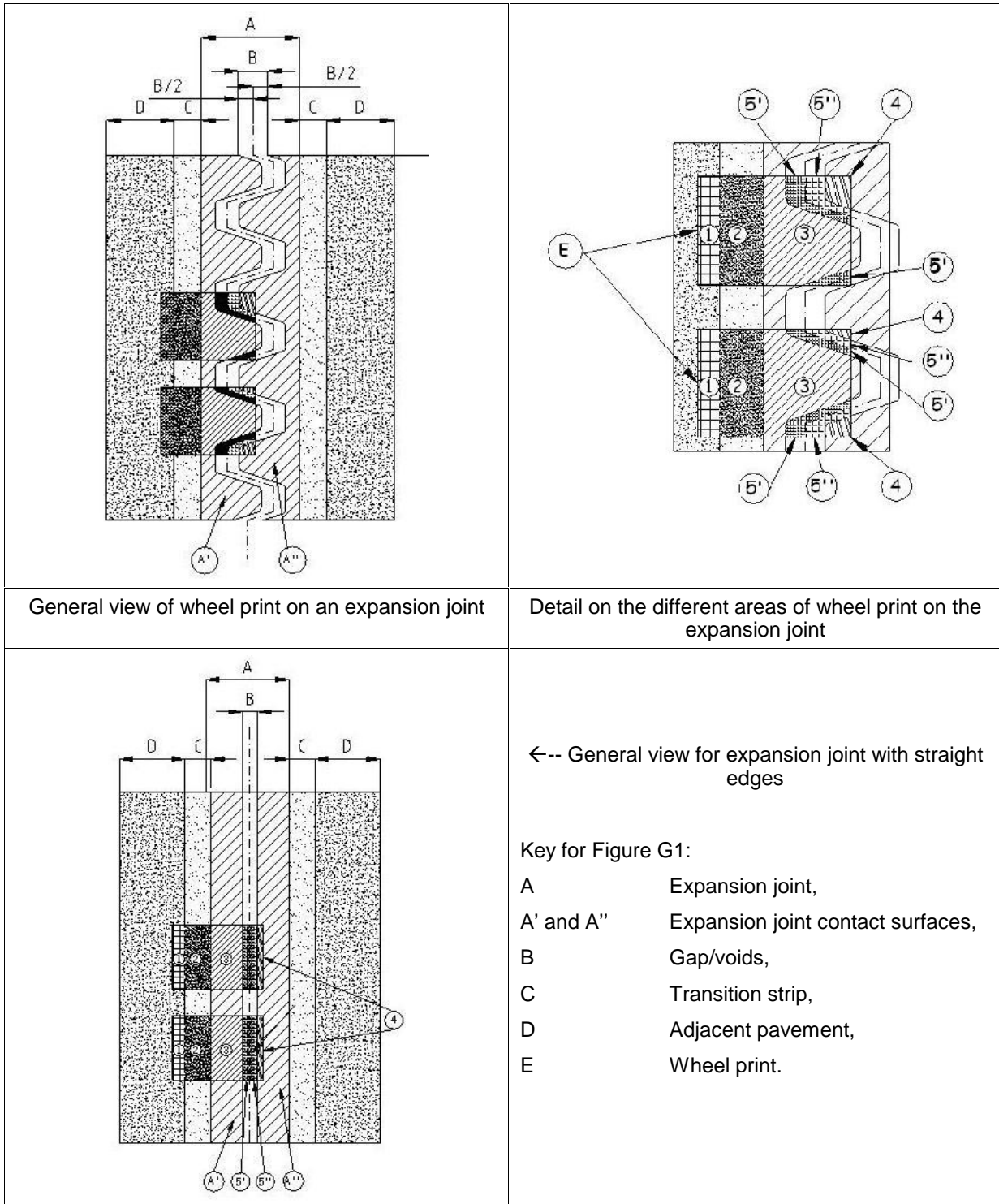
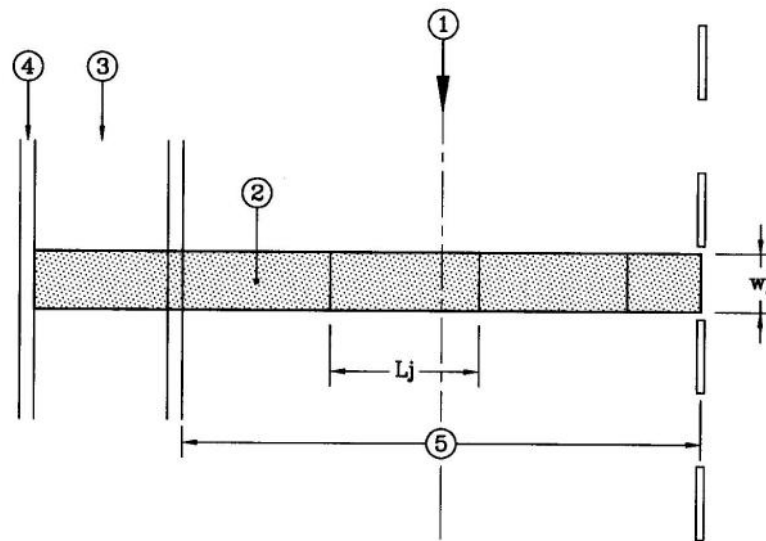

Figure G1: Principles of wheel load application

The loads on the areas of zones 5' and 5'' shall be added on the nearest supporting area of zones 3 and 4 respectively, whereas the load of zone 5' goes to zone 3 and the load of zone 5'' goes to zone 4, unless more detailed in the family Parts.



Key: ① Traffic direction ② Expansion joint ③ Footpath ④ Pedestrian parapet ⑤ Lane

L_j : Influence length,
 W_j : width, in the traffic direction, of the expansion joint at the maximum opening. This width includes the joint itself and the adjacent parts which participate in the load transfer.

Figure G2: Definition of L_j and W_j .

Due attention shall be paid to the skewness of the expansion joint, where relevant.

G.2 – STATIC LOAD MODELS

G.2.1 – VERTICAL LOAD MODEL

The vertical loads are derived from EN 1991-2, 4.3, Load Model 1, with α_{Qi} (see G.2.2.1).

Deviating from EN 1991-2 modified wheel prints are given because expansion joints are surface elements which require a more accurate modelling of the axle load/road surface interaction.

G.2.1.1 – Tandem arrangements

The axle load on one axle of the tandem system TS_n is applied on four wheel prints of two dual tyres, each wheel print with $l = 300$ mm, $b = 250$ mm with a gap between two wheel prints of 100 mm. The inner distance between the wheels prints is 1 300 mm. The geometry is shown in Figure G3.



Units in m.

Figure G3: Wheel print

The tandem systems shall be situated in the most adverse positions on the joint (see Figure G4).

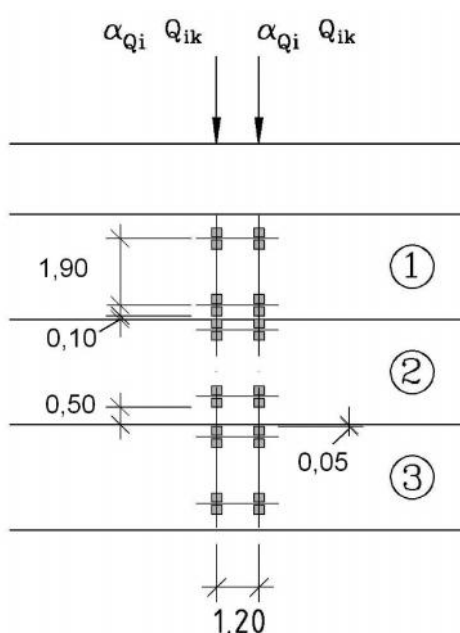

The numbers 1, 2 and 3 correspond to the lane numbers

Figure G4: Tandem system arrangement

Note: If it is demonstrated that the loads in lane 3 are not influencing the design of the expansion joint, they can be omitted.

Table G2 gives the values Q_{ik} of the loads shown in Figure G2 to G4 to be taken into account in conjunction with the geometry of the expansion joint and the structural elements influenced by the traffic load models.

G.2.1.2 – Load Model 1

Only tandem systems TS apply, not the uniformly distributed loads (UDL) as they are not relevant for the expansion joints.

Table G1: Basic values

Location	Tandem system	Axle loads Q_{ik} (kN)
Lane number 1	TS1	300
Lane number 2	TS2	200
Lane number 3	TS3	100

Table G2

Key:  Traffic direction

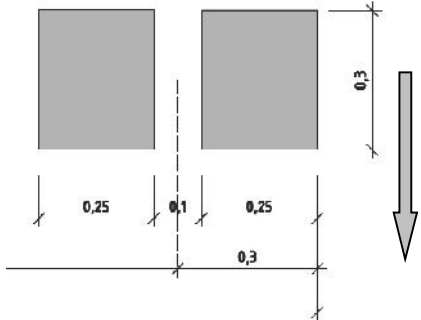
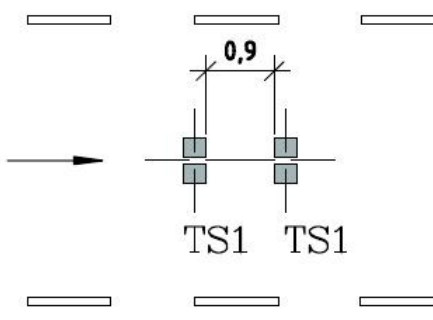
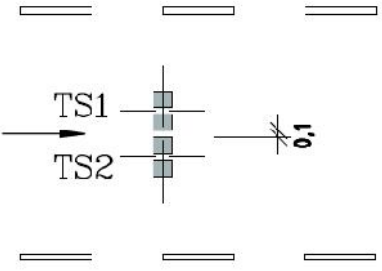
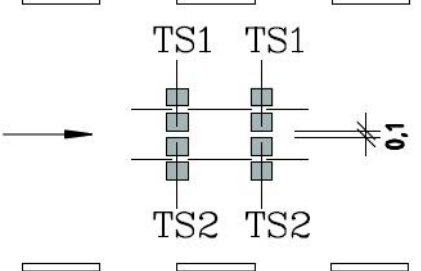
L_j	Wheel and axle loads	
	$W_j \leq 1,20$ m	$W_j > 1,20$ m
$< 0,5$ m	<p>$Q_{ik}/2 = 150$ kN</p>  <p>Figure 1</p>	<p>$Q_{ik}/2 = 150$ kN</p>  <p>Figure 2</p>
$0,5 - 1,60$ m	<p>$Q_{1k}/2 = 150$ kN (TS1) $Q_{2k}/2 = 100$ kN (TS2)</p>  <p>Figure 3</p>	<p>$Q_{1k}/2 = 150$ kN (TS1) $Q_{2k}/2 = 100$ kN (TS2)</p>  <p>Figure 4</p>

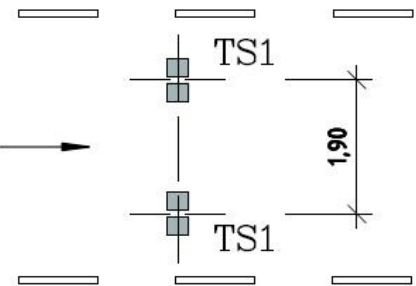
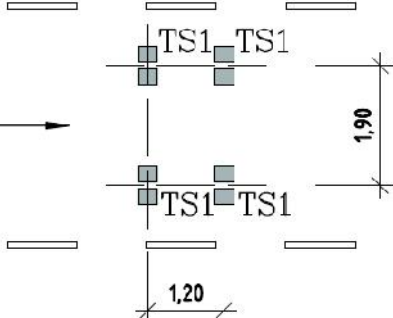
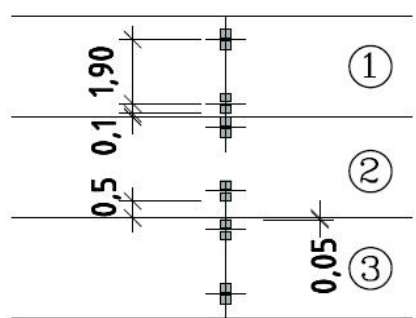
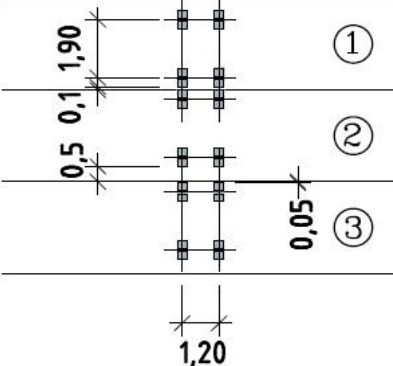
<p>1,60 - 2,50 m</p>	<p>Axle load $Q_{1k} = 300 \text{ kN (TS1)}$</p>  <p>Figure 5</p>	<p>Axle load $Q_{1k} = 300 \text{ kN (TS1)}$</p>  <p>Figure 6</p>
<p>> 2,50 m</p>	<p>See Table G1</p> <p>$\alpha_{Qi} Q_{ik}$</p>  <p>Figure 7</p>	<p>See Table G1</p> <p>$\alpha_{Qi} Q_{ik}$ $\alpha_{Qi} Q_{ik}$</p>  <p>Figure 8</p>

Comments on Table G2:

- (1) The selected position(s) of the axle loads shall be such that they produce the most adverse load effect on the underlying structure between the kerbs. This may result in several load cases with different positions
- (2) The minimum distance between two adjacent wheel shall be taken as 0,10 m perpendicular to the traffic direction.
- (3) The wheel print shall be taken as shown in Figure G3.
- (4) Except for flexible and buried expansion joints, the dispersal effect of the pavement on the expansion joints, if any, shall be disregarded.
- (5) The dynamic amplification is included in the loads, except the effects of resonance.
- (6) The loads given in this clause include the effects of the longitudinal and transverse slopes of the road surface.
- (7) The load models given in this clause include the unequal load distribution on the axles due to centrifugal forces.

G.2.1.3 – Loads on footways

Concentrated load $Q_{fwk} = 35$ kN on a wheel print 200 x 200 mm. With this concentrated load all load effects are covered.

G.2.1.4 – Accidental load

(Vehicle on footways and cycle tracks on expansion joints)

Accidental loads shall be in accordance with EN 1991-2, 4.7.3.1.

(1) Where a safety barrier of an appropriate containment level is provided, consideration of the axle load beyond this point is unnecessary.

(2) Where no safety barrier of an appropriate containment level is provided, one accidental axle load shall be taken into account on the unprotected parts of the joint.

The axle load is:

$$A_d = \alpha_{Q2} Q_{2k} = 200 \text{ kN}$$

[G2]⁴

With the value of $\alpha_{Q2} = 1,0$

⁴ Equation [G1] has been suppressed in this latest version.

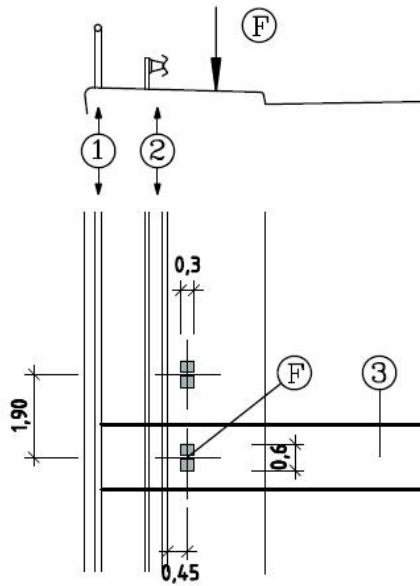

Key: ① Pedestrian parapet ② Safety barrier ③ Expansion joint $F = A_d/2 = 100 \text{ kN}$

Figure G5: Accidental loads on footway

G.2.2 – HORIZONTAL LOAD MODEL

For expansion joints, the horizontal loads are derived from Load Model 1 given in EN 1991-2.

Only tandem systems TS apply, not the uniformly distributed loads UDL as they are not relevant for the expansion joints.

Depending on the width of the expansion joint one axle of a tandem shall be considered when W_j is smaller than or equal to 1,20 m or two axles when W_j is greater than 1,20 m.

G.2.2.1 – Braking and acceleration forces

Braking and acceleration forces are assumed to act in the traffic direction and are derived from Load Model 1, TS1 only.

The braking force applied by one axle on an sub-component of the expansion joint shall be calculated with:

$$Q_{1k} = b_k \times \alpha_{Q1} \times Q_{1k} = 120 \text{ kN} \quad \text{[G3]}$$

The value for α_{Q1} is 1,0 and

$b_k = 0,4$, the characteristic value of the relationship between Q_{1k} / Q_{1k} for the deceleration effect.

- 1) Where relevant, the influence of the second axle of TS1 shall be considered.
- 2) If there are no other requirements in the family Parts, the braking force from a wheel may be distributed on the load carrying sub-components equivalent to the summarized contact stresses, as follows after the subtraction of voids and spaces (see Figure G1). As a result, the horizontal forces may be the forces caused by one wheel or a part of it.
- 3) Braking forces that deviate from the traffic direction do not have to be considered separately as they are covered under G.2.2.2 centrifugal forces.

G.2.2.2 – Centrifugal forces

The centrifugal forces can be derived from Load Model 1.

$$Q_V = \sum \alpha_{Qi} \times Q_{ik} \quad \text{[G4]}$$

The centrifugal forces become:

$$Q_{tk} = 0,2 Q_V \quad \text{[G5]}$$

For an axle on lane 1: $Q_{tk} = 60 \text{ kN}$
 For an axle on lane 2: $Q_{tk} = 40 \text{ kN}$
 For an axle on lane 3: $Q_{tk} = 20 \text{ kN}$

Example: for three axles on lanes 1, 2 and 3: $\sum Q_{tk} = 120 \text{ kN}$

The value for α_{Qi} is 1,0 ($i = 1,3$).

The comments in the note given in Table G.2 apply.

Where relevant, the influence of the second axle shall be considered.

G.2.2.3 – Accidental loads

Collision forces on kerbs of expansion joints.

The expansion joint can be designed for collision forces on kerbs in two possible ways:

- The applied forces shall be in accordance with EN 1991-2, 4.7.3.2 and the structure (expansion joint with kerb unit) is capable of withstanding them without damage.
- The kerb units are repairable and/or replaceable; the collapse does not affect the expansion joint structure.

G.2.2.3.1 – Kerb units not repairable and/or not replaceable

The collapse of the kerb unit does affect the expansion joint structure.

The accidental action A_d from vehicle collision with kerbs is taken as a lateral force F_h equal to 100 kN acting at a vertical surface with a length of 0,5 m and a maximum height of 0,2 m together with a vertical traffic load acting simultaneously with the collision force equal to $0,33 \alpha_{Q1} Q_{1k}$ on a horizontal surface with a length of 0,5 m and a width of 0,1 m (see Figure G6) The value for α_{Q1} is 1,0.

$A_d = 100 \text{ kN}$ (horizontal) “+” 50 kN (vertical)

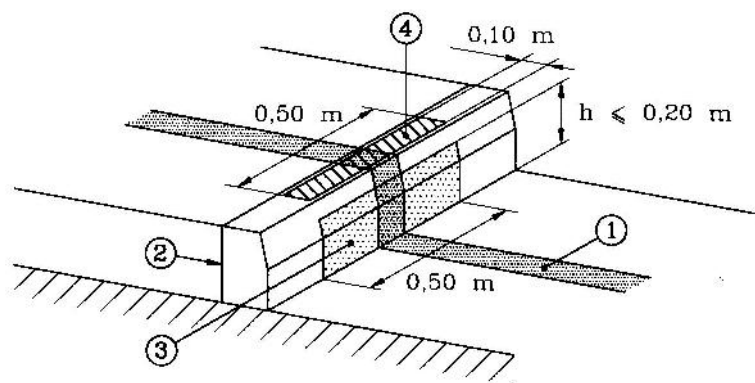

- ① Expansion joint
- ② Kerb
- ③ Vertical surface for lateral force $F_h = 100 \text{ kN}$
- ④ Horizontal surface for vertical force $F_v = 50 \text{ kN}$

Figure G6: Accidental loads on kerbs

G.2.2.3.2 – Kerb units repairable and/or replaceable

The collapse of the kerb unit does not affect the expansion joint structure.

A horizontal load of 10 kN shall be applied on the kerb. No vertical loads are to be applied. The load introduction is the same as to G.2.2.3.1.

An example of these replaceable and/or repairable kerb units is: cover plate.

$A_d = 10 \text{ kN}$ (horizontal)

G.3 – FATIGUE LOAD MODELS

G.3.1 – GENERAL

The Fatigue Load Model 1 (FLM1_{EJ}) and the fatigue Load Model 2 (FLM2_{EJ}) given hereafter are based respectively on FLM1 and FLM4 of EN 1991-2.

Deviating from EN 1991-2 modified wheel prints are given because expansion joints are surface elements which require a more accurate modelling of the axle load/road surface interaction.

The actions, derived from the fatigue load models, which affect the fatigue behaviour, can be vertical, horizontal or a combination of both. The load models in EN 1991-2 include dynamic load amplification appropriate for pavements of good quality, which is also relevant for expansion joints.

The unevenness and the resonance at the expansion joint may result in an additional dynamic factor $\Delta\phi_{fat}$ for vertical loads. For horizontal loads, an additional dynamic factor $\Delta\phi_{fat,h}$, different from the vertical may exist. Upswing after loading (free vibration) shall be considered where relevant. In the family Part more detailed approaches are given, where relevant.

Since there is no interference between effects of successive axle loads, the load models for expansion joints are defined with respect to axle loads only (not vehicles).

For the fatigue assessment of expansion joints FLM1_{EJ} applies. FLM1_{EJ} is intended to be used to check whether the fatigue life may be considered as unlimited.

As an alternative, FLM2_{EJ}, which is a set of equivalent axles, can be chosen by the manufacturer.

Table G3: Axle types, wheel prints and axle geometries

Fatigue load model	Axle type	Wheel print A_w (l x b)	Wheel print axle geometry in transverse direction
FLM1 _{EJ}		300 x 250	Wheel print 250 mm, gap 100 mm, wheel print 250 mm, distance 1300 mm, wheel print 250, gap 100 mm, wheel print 250 mm.
FLM2 _{EJ}	A	300 x 250	Wheel print 250 mm, distance 2 000 mm, wheel print 250 mm.
	B	300 x 250	See FLM1 _{EJ} .
	C	300 x 333	Wheel print 333 mm, distance 1 834 mm, wheel print 333 mm. As an alternative, for sub-components which are not subjected to the total wheel/axle load, axle C can be replaced by axle A.

For the use of this model, the number of vehicles can be selected from EN 1991-2, Table 4.5 and the transverse distribution is given in EN 1991-2, Figure 4.6.

The vertical axle load histogram in Table G3 is derived from EN 1991-2, Table 4.7 for the Traffic type Medium Distance. The number of vertical axle loads per year is found by multiplying the number of vehicles per year from EN 1991-2, Table 4.5 with the axle number rates.

G.3.2 – FATIGUE LOAD MODEL 1 (FLM1_{EJ})

The interaction of the vertical and the horizontal force applied by one axle for slopes in the traffic direction not exceeding 4 % shall be calculated with:

$$Q_{1k, \text{fat}} = \Delta\phi_{\text{fat}} \times Q_{1k} \times 0,7 = 273 \text{ kN} \quad \text{[G.6]}$$

$$\Delta\phi_{\text{fat}} = 1,3 \text{ and } Q_{1k} = 300 \text{ kN}$$

together with:

$$Q_{1k, \text{fat}} = 0,2 \times \Delta\phi_{\text{fat}, h} \times Q_{1k} \times 0,7 = 42 \text{ kN} \quad \text{[G.7]}$$

in traffic direction

$$\Delta\phi_{\text{fat}, h} = 1,0$$

For slopes exceeding 4 % the following applies:

$$Q_{1k, \text{fat}} = (7,0x + 14,0) \text{ kN}$$

x = slope in %

G.3.3 – FATIGUE LOAD MODEL 2 (FLM2_{EJ})

For the use of this model, the number of vehicles can be selected from EN 1991-2, Table 4.5 and the transverse distribution is given in Figure 4.6.

The interaction of vertical and horizontal axle load for slopes in the traffic direction is given in Table G4.

Table G4: Vertical and horizontal loads for fatigue

$Q_{1k,fat}$ Vertical axle load kN Including $\Delta\phi_{fat} = 1,3$	$Q_{1lk,fat}$ Horizontal axle load kN in traffic direction Including $U_{\phi_{fat,h}} = 1,0$	Axle number rate	Axle type
100	-	1,10	A
120	-	1,25	C
150	$y = 3x + 8$	0,20	B
170	$y = 4,5x + 6$	0,45	B
190	$y = 5x + 8$	0,45	B

In which x = slope in % with a minimum value of 4.

The loads mentioned in Table G4, include the following additional dynamic factors $\Delta\phi_{fat} = 1,3$ and $\Delta\phi_{fat,h} = 1,0$. These factors can be modified based on over-rolling tests and/or analyses as indicated in 5.1.1.3.

G.4 – VERIFICATION

G.4.1 – GENERAL

The verifications at the Ultimate Limit State are carried out for full plastic behaviour, taking into account the verification methods given in the relevant European Standards.

The verifications at the serviceability limit state (SLS) evaluate the capability of the expansion joint and its geometry to deal with internal deformations due to the applied loads and with the imposed displacements from the main structure under normal conditions, but also under accidental loads and seismic imposed movements.

In the equations below, the sign “+” means: “In combination with”.

In expansion joints the horizontal loads cannot occur independent of vertical loads. The factor ψ_0 covers the effect from loads arising from the same source.

G.4.2 – COMBINATIONS AT THE ULTIMATE LIMIT STATE

The concurrence of traffic loads and opening positions of the joint is combined within different design situations using combination factors ψ_{0T} , ψ_{0d} , ψ_{0lk} , ψ_{0tk} .

The vertical traffic loads in combinations are derived from Load Model 1.

G.4.2.1 – Traffic loads and design situations (combinations)

This combination of persistent and transient design situations for ULS may lead to various combinations depending on the geometry of the joint sub-components and the influence lines or surfaces associated with it.

$$C_{ULS} = \gamma_{Gi} G_k "+" \gamma_F F_{ik} "+" \psi_{0T} \gamma_{Q1} [Q_{1k} "+" (\psi_{0Ik} Q_{Ik1} "+" \psi_{0tk} Q_{tk1}) "+" Q_{2k} "+" (\psi_{0tk} Q_{tk2}) "+" Q_{3k} "+" (\psi_{0tk} Q_{tk3})] "+" \gamma_{dE} * \psi_{0d} d_{Ek} \quad \text{[G.8]}$$

d_{Ek} = Maximum manufacturer declared opening position of the joint
 F_{ik} = Characteristic internal force

The values of the partial factors γ are given in Table G4 bis and the values of the combination factors ψ_0 are given in Table G5.

Table G4 bis: Partial factors χ

Partial factor	Unfavourable	Favourable	Remark
γ_{Gi}	1,35	1,00	
γ_{F1}	1,20	0,90	In case the consequences of failure are local and/ or minor
γ_{F2}	1,50	0,70	In case the consequences of failure are global and/or major
γ_{Qi}	1,35	Not applicable	
γ_{dE}	1,00	Not applicable	

Table G5: Combination factors ϵ_0

C_{ULS}	Design situation	ϵ_{0T}	ϵ_{0d}	ϵ_{0Ik}	ϵ_{0tk}
1	Reduced opening position with maximum traffic loads, flowing traffic with centrifugal effects	1,00	0,60	0,00	0,50
2	Maximum opening position with reduced traffic loads, braking traffic with centrifugal effects	0,70	1,00	0,50	0,50

ψ_{0T} : combination factor for traffic loads

ψ_{0d} : combination factor for opening position

ψ_{0Ik} : combination factor for traffic loads in the traffic direction

ψ_{0tk} : combination factor for traffic loads perpendicular to the traffic direction

As an envelope approach, covering all design situations, the ψ_0 factors can be taken as follows:

$$\psi_{0T} \text{ and } \psi_{0d} = 1,00$$

$$\psi_{0Ik} \text{ and } \psi_{0tk} = 0,50$$

Example for flowing and braking traffic:

ULS 1, Reduced opening position with maximum traffic loads, flowing traffic with centrifugal effects, unfavourable, consequences of failure due to internal forces are local and/or minor.

$C_{ULS-1} = 1,35 G_k$ vertical "+" 1,2 F_{ik} "+" 1,35 x 1,00 [300 kN vertical "+" (0,00 x 120 kN horizontal longitudinal "+" 0,50 x 60 kN horizontal perpendicular) "+" 200 kN vertical "+" (0,50 x 40 kN horizontal perpendicular) "+" 100 kN "+" 0,50 x 20 kN horizontal perpendicular] "+" 0,6 x d_{Edec}

ULS 2, Maximum opening position with reduced traffic loads, braking traffic with centrifugal effects unfavourable, consequences of failure due to internal forces are local and/ or minor.

$C_{ULS-2} = 1,35 G_k$ vertical "+" 1,2 F_{ik} "+" 1,35 x 0,70 [300 kN vertical "+" (0,50 x 120 kN horizontal longitudinal "+" 0,50 x 60 kN horizontal perpendicular) "+" 200 kN vertical "+" (0,50 x 40 kN horizontal longitudinal) "+" 100 kN "+" 0,50 x 20 kN horizontal perpendicular] "+" 1,00 x d_{Edec}

With $d_{Edec} = \gamma_{dE} d_{Ek}$

Note: Expansion joints may show internal forces from imposed displacements, rotations and/or prestress caused by e.g. compression or elongation, and/or relative movements.

A wheel load is 0,5 times the axle load. The position of the axles shall be in accordance with G.2.1.1 and G.2.1.2. The load portion transfer shall be in accordance with G.1.

Table G6: Information on quasi static loads

Origin	Value	Direction	Positioning	Load portion in accordance to
Self weight, G_k	Defined by manufacturer	Vertical		
Effects of reaction forces, F_{ik}	Defined by manufacturer	-		
Lane 1, Q_{1k}	Axle 300 kN	Vertical	G.2.1.1 and G.2.1.2	G.1
Lane 2, Q_{2k}	Axle 200 kN	Vertical	G.2.1.1 and G.2.1.2	G.1
Lane 3, Q_{3k}	Axle 100 kN	Vertical	G.2.1.1 and G.2.1.2	G.1
Lane 1 Q_{lk1}	Axle 120 kN	Horizontal traffic direction	G.2.1.1 and G.2.1.2	G.1
Lane 1, Q_{tk1}	Axle 60 kN	Horizontal perpendicular to traffic direction	G.2.1.1 and G.2.1.2	G.1
Lane 2, Q_{tk2}	Axle 40 kN	Horizontal perpendicular to traffic direction	G.2.1.1 and G.2.1.2	G.1
Lane 3, Q_{tk3}	Axle 20 kN	Horizontal perpendicular to traffic direction	G.2.1.1 and G.2.1.2	G.1
Accidental loads on footpath and cycle track, A_{k1}	Wheel 100 kN	Vertical	EN 1991-2, 4.7.3.1 (1) and (2)	G.1
Accidental load on kerb, A_{k2}	Wheel 100 kN	Horizontal	EN 1991-2, 4.7.3.2 (1)	G.1

G.4.2.2 – Combinations for accidental situations

This combination of accidental design situations for ULS may lead to various combinations depending on the geometry of the joint sub-components and the influence lines or surfaces associated with it.

On the carriageway no accidental loads are considered. The effect of accidental loads is local (on footpath and kerb) and therefore shall only be combined with the traffic loads on Lane 1.

$$C_{ULS-ACC} = G_k + F_{ik} + \psi_{2k} (Q_{1k} + Q_{lk1} + Q_{tk1}) + A_d + \psi_{2d} d_{Ek} \quad [G.9]$$

ψ_{2k} = Combination factor for quasi-permanent value of a variable action

ψ_{2d} = Combination factor for quasi permanent value of the opening position

Example for accidental vehicle load on kerb:

ULS ACC, unfavourable, consequences of failure due to internal forces are local and/ or minor, simulating flowing traffic.

$$C_{ULS,A2} = G_k \text{ vertical} + F_{ik} + 0,3 [300 \text{ kN vertical} + 120 \text{ kN horizontal longitudinal} + 60 \text{ kN horizontal perpendicular}] + (100 \text{ kN horizontal perpendicular} + 50 \text{ kN vertical}) + 0,6 d_{Ek}$$

The quasi-permanent value of traffic actions on expansion joints corresponds to a lower bound of moving axles, and therefore is not zero.

For the combination $C_{ULS,A1}$ simulating an accidental wheel load on the footpath

$\psi_{2k} = 0,30$, Combination factor for traffic loads

$\psi_{2d} = 0,60$, Combination factor for opening position

For A_d see G 2.1.4.

$$\gamma_{Q2} = 1,0$$

For the combination $C_{ULS,A2}$ simulating an accidental load on the kerb

$\psi_{2k} = 0,30$, Combination factor for traffic loads

$\psi_{2d} = 0,60$, Combination factor for opening position

A_d : see G.2.2.3.1 and G.2.2.3.2.

G.4.2.3 – Combination for seismic design situations

The design approaches and requirements are given in 4.1.1.4, the methods are given in 5.1.1.4, the assessment criteria are given in 6.1.1.4 and the philosophy is further explained in Annex J.

When the design includes provisions limiting movements of the bridge, thus preventing the joint from being affected by seismic effects, no combination for seismic design situations exists. (4.1.1.4, design approach "A1").

In the design approach "A2", the seismic design situation for ULS is given by:

$$C_{ULS-SEISMIC} = G_k + F_{ik} + \psi_{1k} [Q_{1k} + Q_{lk1} + Q_{tk1}] + A_{Ed} \quad [G.10]$$

$\psi_{1k} = 0,4$, Combination factor for frequent value of a variable action

$A_{Ed} =$ Design seismic action (imposed displacements considering the simultaneity of longitudinal, transversal and vertical seismic displacements, for the derivation of the internal forces)

$$A_{Ed} = d_E + d_G + \psi_3 d_{Tk} \quad \text{[G.11]}$$

Where the following displacements shall be combined in the most adverse conditions:

- d_E is the design seismic displacement,
- d_G is the displacement due to the permanent and quasi-permanent long term actions (e.g. relaxation, shrinkage and creep for concrete decks and settlements),
- d_{Tk} is the characteristic displacement due to thermal movements,
- ψ_3 is the reduction factor for the quasi-permanent value of thermal action, according to Table G.7.

The total design seismic displacement shall be increased by the displacement due to second order effects when such effects have a significant contribution.

Example for seismic design situation A2:

ULS seismic, In this combination A_{Ed} represents the conditions (a displacement $d_{Ed} + d_G + 0,5 \times d_{Tk}$) for which the joint is analysed and the internal forces are derived.

$C_{ULS-seismic} = G_k \text{ vertical} + F_{ik} + 0,4 [300 \text{ kN vertical} + 120 \text{ kN horizontal longitudinal} + 60 \text{ kN horizontal perpendicular}] + (d_E + d_G + 0,5 \times d_{Tk})$

The seismic design combinations “A1” and “A2” are selected for seismic actions with a high probability of occurrence or with smaller values for A_{Ed} .

For earthquakes with a low probability of occurrence, approach “B” can be selected in which the failure modes and post failure behaviour are distinguished in accordance with 4.1.1.4.

In the design approaches “B”, the combination of seismic design situations for ULS may lead to various combinations: depending on the geometry of the joint sub-components.

$$C_{ULS-SEISMIC} = G_k + F_{ik} + \psi_{2k} [Q_{1k} + Q_{ik1} + Q_{tk1}] + A_{Ed} \quad \text{[G.12]}$$

ψ_{2k} = Combination factor for quasi-permanent value of a variable action for combinations B1 – B4 as given in Table G7.

A_{Ed} = Design seismic action (imposed displacements d_E , in accordance with [G.11] using ψ_3 as given in Table G7).

Table G7: Seismic design combination factors for approaches A2, B1 – B4

Combination	Combination factor (ψ_3)	Remark
A2	0,50	During earthquake
B1	0,30	-
B2	0,10	-
B3	0,10	During earthquake
	0,20	After earthquake
B4	0,00	During earthquake
	0,20	On the joint after earthquake
	0,00	On the fuses after earthquake

The seismic movement capacity of the joint is extended to values above the requirements of 4.1.4. Limitations for gaps and voids during the seismic event in the running surface are given in the Table G7 or in the parts related to the families.

G.4.2.4 – Combination for fatigue limit state

The fatigue limit state is the situation beyond which the structure has not sufficient bearing capacity due to crack growth after a certain number of load cycles.

The fatigue life shall be evaluated for the most adverse positions of the traffic loads.

The interaction between vertical and horizontal loads shall be considered, where relevant.

Combination for fatigue limit state:

$$C_{FAT} = F_{ik} "+" [Q_{1k,fat} "+" Q_{lk1,fat}] "+" \psi_{0d} d_{Ek} \quad [G.13]$$

$\psi_{0d} =$ 0,6 Combination factor
 $d_{Ek} =$ Maximum declared opening position of the joint (for the relation between d_{Ek} and d_{Edec} , see G.4.2.1).

The value of factors $\Delta\phi_{fat}$ and $\Delta\phi_{fat,h}$ is given in G.3.2.

$Q_{1k,fat}$ and $Q_{lk1,fat}$ in [G.13] are axle loads in relation to the number of vehicles for the fatigue load model considered, for FLM1_{EJ} the number of vehicles is irrelevant, for FLM2_{EJ}, see G3.3.

Example for fatigue for verification of unlimited fatigue life:

$C_{FAT} = F_{ik} "+" [210 \text{ kN vertical } "+" \Delta\phi_{fat,h} 42 \text{ kN horizontal}] "+" 0,60$ maximum declared opening position of the joint.

Where relevant, the free vibration and damping effect shall be considered.

G.4.3 – COMBINATIONS AT THE SERVICEABILITY LIMIT STATE

Symbols as for ULS combinations.

G.4.3.1 – Characteristic combination

The loads shall be combined as defined below.

$$C_{SLS} = G_k "+" F_{ik} "+" \psi_{0T} [Q_{1k} "+" (\psi_{0lk} Q_{lk1} "+" \psi_{0tk} Q_{tk1}) "+" Q_{2k} "+" (\psi_{0tk} Q_{tk2}) "+" Q_{3k} "+" (\psi_{0tk} Q_{tk3})] "+" \psi_{0d} d_{Ek} \quad [G.14]$$

$F_{ik} =$ Characteristic internal force
 $d_{Ek} =$ Maximum declared opening position of the joint (for the relation between d_{Ek} and d_{Edec} , see G.4.2.1).

The values of the combination factors ψ_0 are given in Table G5.

As an envelope approach, covering all design situations, the ψ_0 factors can be taken as follows:

$$\psi_{0T} = 1,00, \psi_{0d} = 1,00, \psi_{0lk} = 0,50, \psi_{0tk} = 0,50$$

Example for characteristic combination:

SLS, Reduced opening position with maximum traffic loads, flowing traffic with centrifugal effects,

$C_{SLS,CHAR} = G_k "+" F_{ik} "+" 1,00 [300 \text{ kN vertical } "+" (0,00 \times 120 \text{ kN horizontal longitudinal } "+" 0,50 \times 60 \text{ kN horizontal perpendicular}) "+" 200 \text{ kN vertical } "+" (0,50 \times 40 \text{ kN horizontal perpendicular}) "+" 100 \text{ kN vertical } "+" (0,50 \times 20 \text{ kN horizontal perpendicular})] "+" 0,6 \times d_{Ek}$

G.4.3.2 – Frequent combination

The relevant design situation is flowing traffic.

Combination is:

$$C_{SLS-FREQUENT} = G_k + F_{ik} + \psi_{1T} [Q_{1k} + \psi_{0ik} Q_{1k1} + Q_{2k} + Q_{3k}] + \psi_{1d} d_{Ek} \quad [G.15]$$

ψ_1 = Combination factor for variable actions

$$\psi_{0ik} = 0,50$$

$$\psi_{1T} = 0,70$$

$$\psi_{1d} = 0,60$$

Example for frequent combination:

SLS, unfavourable, simulating flowing traffic.

$$C_{SLS,FREQUENT} = G_k + F_{ik} + 0,7 [300 \text{ kN} + 200 \text{ kN} + 100 \text{ kN}] + 0,6 \times d_{Ek}$$

LIST OF ABBREVIATIONS

Abbreviation	Explanation	Reference
	Latin upper case letters	
A_{Ed}	Design seismic action	EN 1990, 1.6
C_{FAT}	Combination for fatigue limit state	
C_{SLS}	Combination for serviceability limit state	-
$C_{SLS-FREQUENT}$	Frequent combination	-
C_{ULS}	Combination of persistent and transient design situations for ULS	-
$C_{ULS-ACC}$	Combination for accidental design situation	-
$C_{ULS-SEISMIC}$	Combination for seismic design situation	-
C_{SLS}	Combination for serviceability limit state	-
$C_{SLS-FREQUENT}$	Frequent combination	-
FLM1	Fatigue load model 1	EN 1991-2, 4.6.1 and 4.6.2
FLM2 _{EJ}	Fatigue load model 2 for expansion joints	
FLM1 _{EJ}	Fatigue load model 1 for expansion joints	
FLM4	Fatigue load model 4	EN 1991-2, 4.6.1 and 4.6.5
F_{ik}	Characteristic internal force caused by prestress and imposed deformations	-
G	Self weight (permanent action)	EN 1990, 1.6
LM1	Static load model 1	EN 1991-2, 4.3.1 and 4.3.2
L_j	Structural (effective) length of the joint	-
$P_{D-wheel}$	Design vertical wheel load	-
S	Wheel print area	-
SLS	Serviceability limit state	EN 1990, 6.5
S_v	Area of gaps and voids	-
Q_v	Summarized adjusted vertical loads for the determination of the summarized centrifugal load	-
Q_{fwk}	Concentrated vertical load simulating pedestrian loads	EN 1991-2, 1.5.2 and 5.1
Q_{ik}	Vertical load of one axle at lane "i"	EN 1991-2, 4.3.1 and 4.3.2
Q_{lk}	Braking load of one axle	EN 1991-2, 1.5.2 and 4.4.1
Q_{tk}	Centrifugal force	EN 1991-2, 1.5.2 and 4.4.2
$Q_{1k, fat}$	Vertical axle load of FLM1 _{EJ}	
$Q_{1lk, fat}$	Horizontal axle load of FLM1 _{EJ}	
Q_{2k}	Accidental vertical characteristic traffic load	EN 1991-2, 4.7.3.1
TSi	Tandem system vertical load on lane "i"	EN 1991-2, 1.5.2 and 4.3.2
ULS	Ultimate limit state	EN 1990, 6.4
W_j	Effective width of the expansion joint at maximum opening position	-
	Latin lower case letters	
b_k	Characteristic value of the deceleration effect	-

d_{Ek}	Maximum opening of the joint declared by the manufacturer	-
d_E	Design seismic displacement of the joint	-
d_G	Opening position of the joint due to displacement caused by permanent and quasi-permanent long term actions on the main structures	-
d_{Tk}	Opening position of the joint due to displacement caused by movements caused by thermal actions on the bridge	-
Greek upper case letters		
$\Delta\phi_{fat}$	Additional dynamic factor for vertical axle loads for fatigue	EN 1991-2, 1.5.2 and 4.6.1
$\Delta\phi_{fat,h}$	Additional dynamic factor for horizontal axle loads for fatigue	-
Greek lower case letters		
α_{Qi}, α_{qi}	Adjustment factors of some lane load models on lanes i ($i = 1, 2, \dots$)	EN 1991-2, 4.3.2
α_{Q2}	Adjustment factors for accidental load model	EN 1991-2, 4.3.2 and 4.7.3.1
γ_{F1}	Partial load factor in case the consequences of failure are local and/ or minor	-
γ_{F2}	Partial load factor in case the consequences of failure are global and/ or major	-
γ_G	Partial load factor for permanent actions	EN 1990, 1.6
γ_{Qi}	Partial load factor for variable actions (axle loads: TSi)	EN 1990, 1.6
γ_q	Partial load factor for variable actions (distributed loads: UDL)	EN 1990, 1.6
$\sigma_{Contact}$	Contact pressure between wheel and expansion joint surface	
ψ_{0T}	Combination factor for traffic loads	-
ψ_{0d}	Combination factor for opening position of joint	-
ψ_{0lk}	Combination factor for traffic loads caused by braking lorries	-
ψ_{0tk}	Combination factor for traffic loads caused by centrifugal effects on lorries	-
ψ_{2k}	Combination factor for quasi-permanent value of a variable action	EN 1990, 1.6
ψ_{2d}	Combination factor for quasi-permanent value of the opening position of the joint	-
ψ_{1k}	Combination factor for frequent value of a variable action	EN 1990, 1.6
ψ_3	Combination factor for the quasi-permanent value of thermal actions	-
Explanation		
-	Only used in Annex G, no references	

Annex H

NUMBER OF PRODUCTS TO BE TESTED

This annex is used to indicate the number of model(s) chosen in a range for approval testing.

Definition of type 1 and type 2

Type 1: the model of expansion joint is unique. Its design and functional principle are only on one product and one nominal movement capacity.

or

The model of expansion joint is an element of a range with the same design, the same components and the same functional and the same functional principle. This type is limited to products with a nominal movement capacity less than or equal to 240 mm. The product is chosen in the middle of the range.

Type 2: the model of expansion joint is an element of a range with the same design and the same functional principle with a nominal movement capacity strictly above 240 mm.

Performance characteristics	Number of products to be tested		Comments
	Type 1	Type 2	
5.1.1 Mechanical resistance and stability			
5.1.1.2 Mechanical resistance			
5.1.1.2.1 Calculations	Not relevant	Not relevant	Verification by calculation.
5.1.1.2.2 Testing	(2)	3* of each variable element (2)	Some types of joints may not need testing. * One test at each border of the range and one test in the middle of the range.
5.1.1.3 Resistance to fatigue			
5.1.1.3.1 Calculations	Not relevant	Not relevant	Verification by calculation.
5.1.1.3.2 Testing	(2)	3* of each variable element (2)	Some types of joints may not need testing. * One test at each border of the range and one test in the middle of the range.
5.1.1.4 Seismic behaviour	Not relevant	Not relevant	Select approach declared.
5.1.1.5 Movement capacity	1	3 *	Except where required in family Part: analysis of the design. * One test at each border of the range and one test in the middle of the range except if, for this last test, extrapolation/ interpolation is possible.
5.1.1.6 Cleanability	Not relevant	Not relevant	Analysis of technical file and drawings.
	1	1	In case of test.
5.1.1.7 Resistance to wear	1	1	See relevant family Part.
5.1.1.8 Watertightness	1	3 *	To be defined in the family Part.
			* One test at each border of the range and one test in the middle of the range except if, for this last test, extrapolation/ interpolation is possible.

Performance characteristics	Number of products to be tested		Comments
	Type 1	Type 2	
5.1.3 Hygiene, health and environment (release of dangerous substances)	Not relevant	Not relevant	List
5.1.4 Safety in use			
5.1.4.1 Ability to bridge gaps and levels in the running surface			
5.1.4.1.1 Allowable surface gaps and voids	All	All	
5.1.4.1.2 Level differences in the running surface	(1)	(1)	Analysis of technical file and drawings and/or indication in the family Part.
5.1.4.2 Skid resistance	1	1 (One test in the range.)	The test is only required if the conditions given in 4.1.4.2 apply.
5.1.4.4 Drainage capacity	Not relevant	Not relevant	Analysis of technical file and drawings.
5.1.7.1 Aspects of durability	1	1	If applicable according ETAG Part 1 and/or family Part.

(1) Additional indication could be added according to the family Part.

(2) In principle, one sample has to be tested. In case of unknown designs and depending on the material behaviour more than one sample may be needed. This has to be agreed between the Approval Body, the testing body and the ETA applicant based on the principles given in EN 1990.

Note: A test accessing a performance characteristic may be used for different kits.

Annex J

SEISMIC APPROACH

DESIGN PHILOSOPHY FOR RBEJ

The objective of this annex is to give sufficient background information to the Approval Bodies for the consideration of the seismic design situation to be used in the approval procedure.

J.1 – INTRODUCTION

For the total design displacement under seismic conditions in accordance with EN 1998-2, an adequate structural gap is required to protect critical or major structural elements from damage.

The design displacement is determined under consideration of seismic actions and the long-term effect of the permanent and quasi-permanent actions and includes an appropriate fraction of the displacement due to thermal movements.

Generally after the design seismic event, sufficient bearing capacity shall remain for emergency vehicles with appropriate reliability.

Local damage to the expansion joint due to the design earthquake is admissible.

- 1) For earthquakes with high probability of occurrence only damage with no need of immediate repair and no influence to the traffic safety are generally allowed.
- 2) The total value of the design displacement under seismic conditions d_{Ed} by reference to EN 1998-2, 2.3.6.3 is determined as follows:

$$d_{Ed} = d_E + d_G + \psi_2 d_T$$

Where:

- d_E is the design seismic displacement,
- d_G is the displacement due to the permanent and quasi-permanent actions measured over the long term (e.g. post-tensioning, shrinkage and creep for concrete decks),
- d_T is the displacement due to thermal movements,
- ψ_2 is the reduction factor for the quasi-permanent value of thermal action, according to Tables A2.1, A2.2 or A2.3 of Annex A2 of EN 1990. The total design seismic displacement shall be increased by the displacement due to second order effects when such effects have a significant contribution.

Attention shall be paid to the supporting conditions induced by larger initial bridge deck gap and to the influence of the displacement speed and acceleration during the earthquake.

Values of the displacement generated by seismic phenomena can be reduced by seismic devices and/or provisions in the bridge design limiting the structure movement.

J.2 – MOVEMENT CAPACITY CASES

A) Movement capacity design

This design method can be applied for bridges with small seismic displacements (recommended value $d_{Ed} = 200$ mm) and depends on techno-economical considerations.

A-1 - Expansion joints with movement capacity SLS condition even during earthquake.

Standard expansion joints can be used if they provide under serviceability conditions according to 4.1.1.5 the total movement capacity required for displacement d_{Ed} .

A-2 -Expansion joints with movement capacity for the total displacement d_{Ed}

The seismic movement capacity of the joint is extended to values above the requirements of 4.1.4.1. Limitations for gaps and voids during the seismic event in the running surface are given in the Table 4.1.4.1 or in the parts related to the families.

The resistance to static actions during the earthquake shall be checked for the frequent combination of actions as per EN 1990. No fatigue design is required for this condition.

The expansion joint is assumed to be resistant to any other kind of effects given in this ETAG after the design earthquake and no repair work has to be applied.

B) Restricted movement and load capacity design

For larger seismic displacements (recommended value $d_{Ed} > 200$ mm) the design according to mode A becomes uneconomic. Therefore smaller or controlled damage can be accepted for severe earthquakes. Structural gaps shall accommodate appropriate fractions of the design seismic displacement and thermal movement, after allowing for any long term creep and shrinkage effects, so that damage under frequent earthquakes can be avoided. The appropriate values of such fractions depend on national regulations.

Earthquakes with high probability of occurrence during the intended working life of the expansion joint should not create any damage and therefore be in accordance with the requirements of one of the modes A. Appropriate values for the seismic movement have to be used. In the absence of an explicit optimisation the following value is recommended:

- 40% of the design seismic displacement and
- the frequent combination of other movements in accordance with EN 1990.

J.3 – BRIDGES WITH FUSIBLE LINKS

Specially to isolate bridges against seismic inputs and to limit seismic actions, fusible links are provided to bear horizontal loads during the service condition. After the fuse is activated, the movement design requirements (amplitude and direction) for the expansion joint are changed.

Such functioning is out of the scope of this ETAG.

Annex K

MOVEMENT CAPACITY TEST METHOD

K.1 – OBJECT

This annex specifies a method to assess by testing the ability of an expansion joint to accommodate the movements of the structure. These movements are evaluated in three dimensions.

K.2 – SCOPE

Where the movement capacity of the expansion joint is influenced by the temperature (see 2.3.2: Assumptions - Temperatures), this influence shall be evaluated and if relevant take into account in movement capacity test procedure.

The test is carried out in the laboratory on a sample of expansion joint for road bridges with a representative length of at least 1 metre (exception subject to agreement with Test Bodies).

K.3 – TERMS AND DEFINITIONS

For the needs of this annex, the following terms and definitions apply.

K.3.1 – MOVEMENT

The variation of the distance between the parts of the structures supporting the expansion joint.

K.3.2 – MOVEMENT CAPACITY

The declared range of the relative displacement between the extreme positions (maximum opening and closing) of an expansion joint not leading to damage of the product tested.

K.3.3 – HORIZONTAL DISPLACEMENT

Movement in a horizontal plane imposed on the product tested along an axis perpendicular to the principal axis of the joint.

K.3.4 – VERTICAL DISPLACEMENT

Movement imposed on the product tested along a vertical axis. It corresponds in particular to the vertical component of rotations of the deck relative to the abutment.

K.3.5 – TRANSVERSE DISPLACEMENT

Movement imposed on the product tested along the axis of the joint (occurs on skew bridges, effect of the centrifugal force on the curved bridges, ...).

Relation transactional movement of "2" with respect to "1" (see Figure K1).

X	Main direction along an axis perpendicular to the principal axis of the joint	In "horizontal" plane	Variable by actuator
Y	Transverse		Variable by actuator
Z	Vertical		Variable or constant by mechanical devices filling plates or actuator

Movements in x, y and z may be combined.

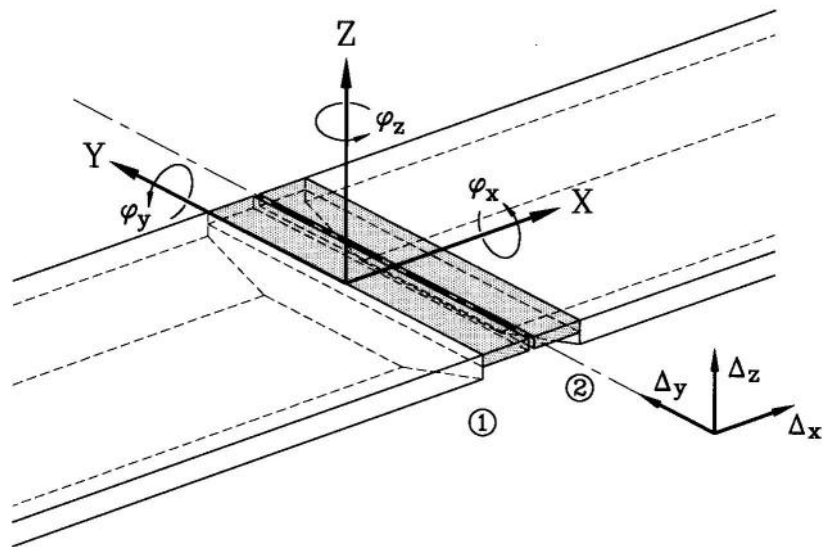

Figure K.1: Combination of movements

K.3.6 – GAP

For definition, see Terminology, 3.2.1.

K.4 – PRINCIPLE

A sub-component or a section from an element of an expansion joint for road bridges is fixed in a frame with moving parts allowing a horizontal displacement normal and parallel to the bridge deck gap axis.

Vertical displacement can be generated by a device ensuring a continuous displacement or by shim plates under one of the tested joint supports. The principle of the test frame is represented in Figure K.2.

The device shall be equipped to measure the values of the movements and the forces necessary to obtain the displacements.

K.5 – EQUIPMENT

The testing machine consists of a frame including one or two moving supports allow the fixing of the joint.

Requirements on testing machine:

- The stiffness of the machine shall be such that the generated forces in the expansion joint tested do not influence the results of the measurement.
- Friction forces in the testing equipment shall not influence the measured results by more than 10 %.
- The movement capacity in each degree of freedom of the testing machine shall be sufficient in order to be able to carry out the test.
- The connections of the test specimen at the testing machine shall be rigid enough to avoid uneven movement in the connections.

Vertical displacements shall be possible for an offset of 20 mm.

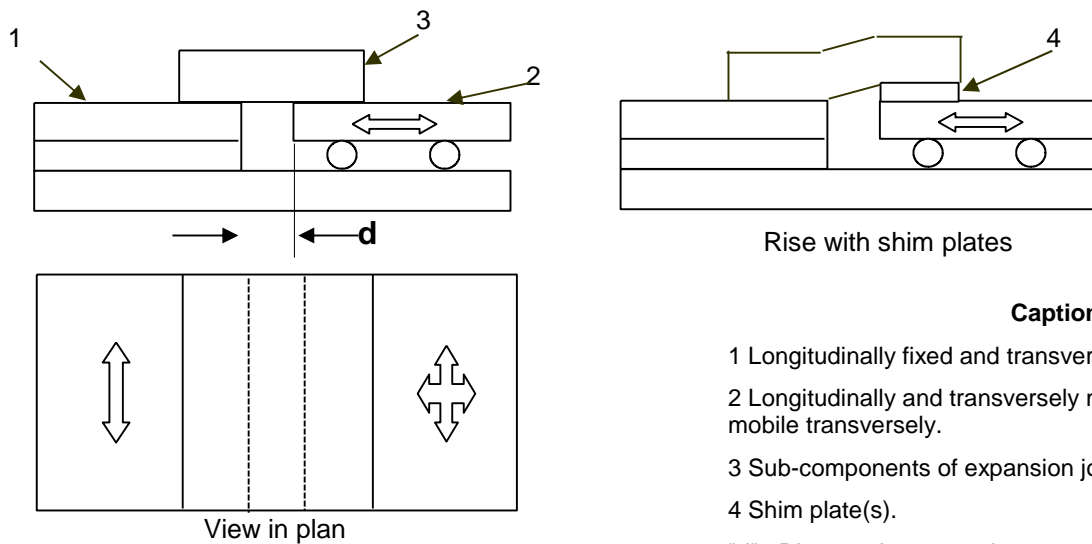

Figure K.2: Example of a test assembly

Displacements are generated by devices whose type and capacity are appropriate to the model of joint tested.

In the test reaction forces and deformations of the sample shall be measured.

The measurement of loads and deformations together with the type of sensors and their location at the test specimen is specified before the beginning of the test.

For materials subject to a load-dependent creep, the creep and relaxation effects in time shall be evaluated and taken into account.

The displacement measurements are carried out using comparators or possibly incremental position sensors allowing the recording of the test data.

The accuracy of the measuring apparatus of the forces will be 5 % of the maximum reaction force, the resolution of the incremental position sensors shall be $\pm 1/10$ mm, in order to obtain a precision of measurements of the order of ± 1 mm.

K.6 – SAMPLES AND PREPARATION OF TEST SPECIMENS

K.6.1 – DIMENSIONS

The joint sample shall be representative of the assembled expansion joint. Where relevant in the expansion joint, the test piece shall comprise assembly details between adjacent parts in the longitudinal direction of the expansion joint.

The exact length of the sample is fixed by agreement between the manufacturer and the test laboratory according to the type of product in order to avoid cuts modifying the operating mode.

The minimum length of the test specimen shall be 1 m unless otherwise specified in relevant family Part.

Note: It is recommended that the test specimen has a length corresponding to the nominal length of a standard manufactured element.

K.6.2 – CONTROL OF SAMPLES

The product tested shall be in conformity with the manufacturing drawings and the specifications including the tolerances.

It shall be verified that the samples comply with the specifications.

The number of test samples is one. It is recommended for products which show a variation in functioning, to use 3 test samples.

K.6.3 – INSTALLATION OF SAMPLES ON THE TEST FRAME

The product to be tested shall be installed in the testing rig under the control of the manufacturer and shall comply with the installation procedure.

K.7 – PROCEDURE

K.7.1 – TESTING CONDITIONS

The test is carried out under the following conditions:

- Test temperature

The ambient temperature during the tests shall be between +5 °C and +35 °C. Where relevant, the family Part gives details if the ambient temperature, defined in this clause, is not appropriate for carrying out the test and which procedures for testing are applicable.

- Test speed

The speed of longitudinal and transverse displacements during the test shall not exceed 1 mm/s between the stages of observation. A complete cycle shall not exceed 24 hours.

K.7.2 – TEST PROCEDURE

Check and record the test temperature.

Fix the devices of measuring of displacements so that the movements are correctly recorded.

The test specimen shall be subjected to movements which simulate opening and closing of the joint.

The test comprises 6 cycles (See Figure K.3). For each cycle, the maximum relative displacement of the test specimen as designed by the producer is subdivided into a minimum of 4 steps, each 25 % of the maximum relative displacement. The test may start at any desired position within the maximum relative displacement. After completion of each step, a dwell period is allowed.

During cycle 1 and cycle 5, the displacements are measured together with the reaction forces.

During the 5th cycle, the transverse movement capacity is verified in combination with the total range of longitudinal movement and the values of corresponding reaction forces are recorded.

For the joints having a symmetrical operation under transverse solicitation, the checking will be done in one direction only.

In a 6th cycle the supports are positioned with a vertical offset in order to simulate the unevenness of supports. Only opening and closing movements are applied, no transverse movements. When the joint has a different behaviour for an upward movement compared to a downward movement both directions shall be measured.

The behaviour and the appearance of the joint shall be recorded.

Note: Parts of this test procedure will be used for the derivation of fatigue tests by imposed deformations according to 4.1.1.3.

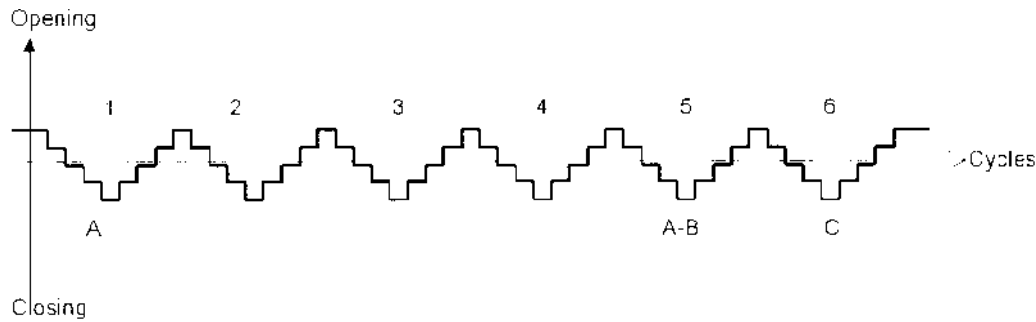

- A: Measure of F at opening and closing position
- B: Transversal movement with opening/closing movement
- C: Vertical movement with opening/closing movement

Figure K.3: Description of cycles during test procedure for movement capacity

K.8 – EXPRESSION OF RESULTS

Displacements are expressed in mm and the forces in N.

The following results are recorded and expressed using figures and/or graph(s) where appropriate:

- Measurements "d" reached during 1st and 5th cycles (opening, closing) (see K.3);
- Graphs of force/deformation as recorded in the cycles 1, 4, 5, 6;
- Maximum transverse displacement(s) during the 5th cycle;
- Measurements "d" reached during the 6th cycle with unevenness and its corresponding value;
- Forces corresponding to each position previously written;
- Observations of behaviour shall be described and supported with photographs.

K.9 – TEST REPORT

The test report shall refer to the present annex and mention:

- The origin of the expansion joint to be tested (the name of the manufacturer, the name of the production centre);
- The model identification (type, theoretical movement capacity, N° of batch);
- A reference to this annex and any deviation from it;
- Description of the test equipment;
- The date of the preparation of specimens, the date of test and the mean test temperature;
- The statement of principal dimensions which allow for unique identification of the product tested;
- A brief description of the test conditions (assembly, description of the sample, speed of displacements, stages, ...);
- Values of displacements and the forces related obtained during the test;
- Observations on the behaviour corresponding to each stage;
- Test conditions and operational details not envisaged in this document as well as the possible incidents likely to have affected the results.

A description of any disorder and operating mode possibly appearing on the joint (cracking of rubber, rolling off the rim, abnormal deformations, etc.) is made for each stage of the test procedure.

Annex L

WATERTIGHTNESS TEST METHOD

L.1 – SCOPE

This annex describes a test method for water tightness of an expansion joint.

This test method is not intended as a verification of drainage systems or collection of water by means of additional devices.

This annex gives guidance on how to test whether an expansion joint, in its design (thus before the product is exposed to traffic loads), is ready to prevent percolation of water (Remark: percolation is different to moisture at bottom surface).

The test is carried out to verify that water cannot pass through the expansion joint.

The test is carried out on a representative sample of an expansion joint in laboratory conditions out of traffic.

In the case of design of an expansion joint where the device ensuring the waterproofing (or the existence of a discharge drainage system) is positioned below the riding surface (beyond 50 mm), the method of test has to be agreed between the manufacturer, Approval Body and the testing laboratory.

L.2 – DEFINITIONS

See 3.2 of this ETAG.

L.3 – PRINCIPLE

The full-scale representative sample of the expansion joint includes all components and at least one connection if applicable and an upstand.

The test shall be carried out on one sample.

The test involved subjecting the sample of the expansion joint to the action of a defined head of water on the joint.

There shall be no moisture under the joint.

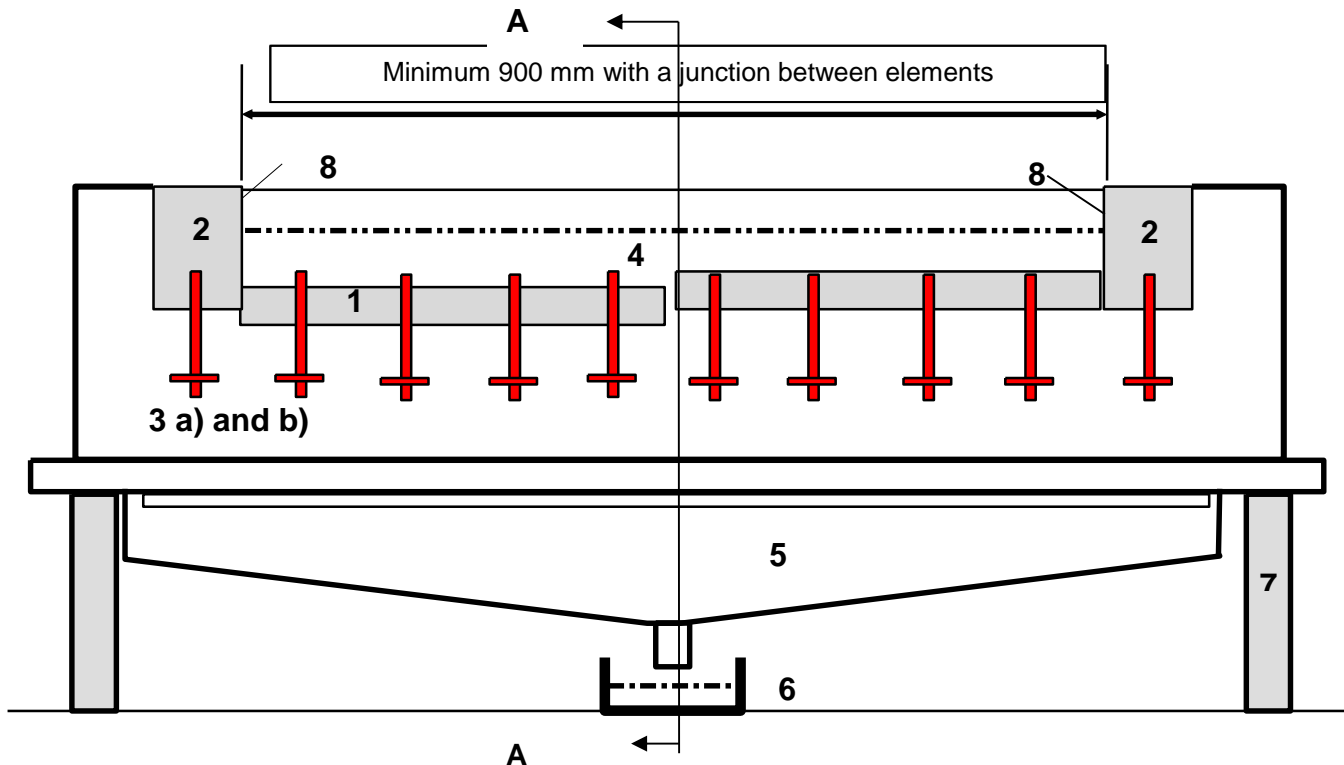

Key

- 1 Expansion joint test piece with, where relevant, longitudinal assembly details
- 2 Upstand
- 3 Concrete blocks forming test box a) and b)
- 4 Height of water H
- 5 Receptacle
- 6 Cup
- 7 Structure of test support
- 8 Cofferdam or provisionally raised part
- 9 Opening
- 10 Part maintaining the joint in opening position

L.1.a: Elevation

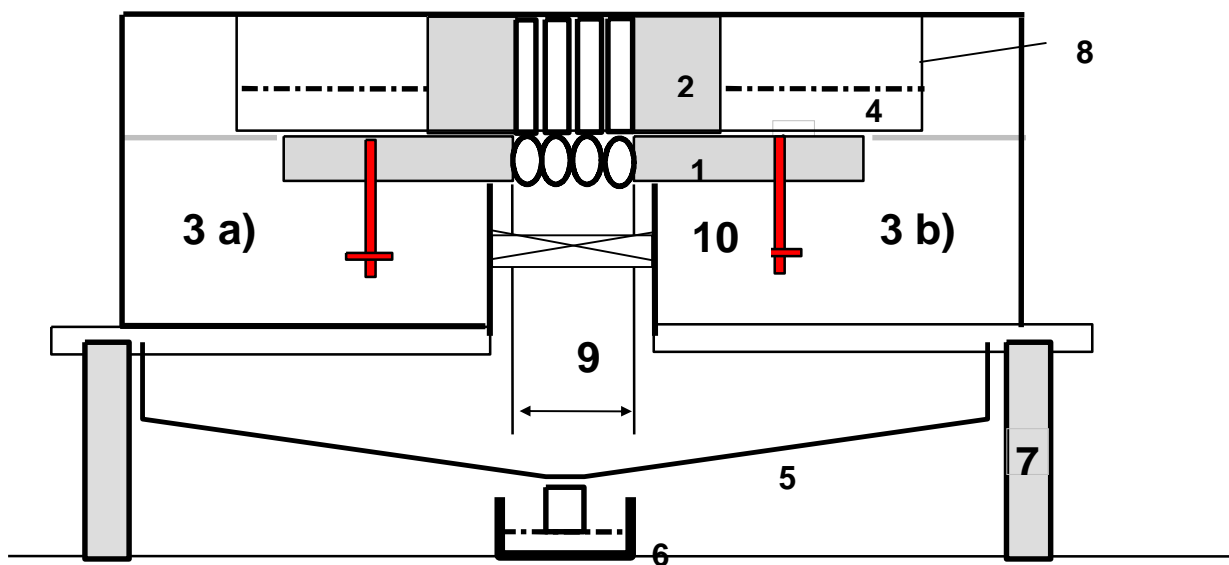

L.1 b: Cross section AA

Figure L.1: Example of test rig

L.4 – SAMPLES AND PREPARATION OF TEST SPECIMENS

L.4.1 – DIMENSIONS

The full-scale representative sample of the expansion joint shall include all components and at least one connection if applicable and an upstand.

The joint sample shall be representative of the assembled expansion joint. Where relevant in the expansion joint, the test piece shall comprise assembly details between adjacent parts in the longitudinal direction of the expansion joint. The exact length of the sample shall be fixed by agreement between the manufacturer, the Approval Body and the test laboratory according to the type of product.

The minimum length of the test specimen shall be 1 m.

L.4.2 – CONTROL OF SAMPLES

The tested product shall be in conformity with the manufacturing drawings and the specifications including the tolerances.

It shall be verified that the samples comply with the specifications.

The number of test samples shall be one.

L.4.3 – INSTALLATION OF SAMPLES ON THE TEST FRAME

The product to be tested shall be installed in the testing rig under the control of the manufacturer and shall comply with the procedure established by the manufacturer for the installation on the test rig.

L.4.4 – TEST RIG

The principle of the test rig is shown in Figure L.1.

L.5 – TEST PROCEDURE

L.5.1 – BEGINNING OF THE TEST

The test shall be carried out after the materials are fully cured and set in the test rig in accordance with the installation procedure manual, within a time defined by agreement between the manufacturer, the Approval Body and the testing laboratory.

L.5.2 – TEST TEMPERATURE

The temperature during the test shall be between +5 °C and +30 °C.

L.5.3 – EXECUTION OF THE TEST

The sample is assembled in accordance with Figure L.1. The opening of the joint shall be fixed at the nominal maximum opening declared by the manufacturer of the product.

Where relevant, the value of opening used for testing is modified in the family Part.

Note: Depending of the type of product and the condition of functioning, the opening will be defined in the worst condition of opening.

The test is carried out with potable water.

The minimum head shall be 30 mm at the highest location of the sample. Where relevant, deviation from this last value is specified in each family Part.

Note: A maximum head larger than 50 mm is not considered necessary.

The duration of the test is 6 hours.

During the testing continuous visual inspection shall be carried out to detect leakage. In the event of leakage the test shall be stopped. Locations where leakage has been observed are to be reported.

L.6 – EXPRESSION OF THE RESULTS

The openings are stated in millimetres.

The head shall be given in millimetres.

Times are expressed in hours. The air temperature during the test is expressed in degrees Celsius.

Pass/fail results.

In case of failure the location and the significance shall be reported.

L.7 – TEST REPORT

The test report shall include:

- The origin of the expansion joint to be tested (the name of the manufacturer, the name of the production centre);
- The model identification (type, theoretical movement capacity, N° of batch);
- A reference to this annex and any deviation from it;
- Description of the test equipment;
- The date of the preparation of specimens, the date of test and the test mean temperature;
- The statement of principal dimensions which allow for unique identification of the product tested;
- A brief description of the test conditions (head of water, opening test, test duration, description of the sample, ...);
- Test conditions and operational details not envisaged in this document as well as the possible incidents likely to have affected the results.
- Results of watertightness test (pass, fail, leakage location, etc.).