

OECD GUIDELINE FOR THE TESTING OF CHEMICALS

Simulation Test - Aerobic Sewage Treatment: 303 A: Activated Sludge Units - 303 B: Biofilms

303 A: Activated Sludge Units

INTRODUCTION

1. In the 1950s it was realised that the newly introduced surfactants caused excessive foaming in waste water treatment plants and in rivers. They were not fully removed in the aerobic treatment and in some cases limited the removal of other organic matter. This instigated many investigations into how surfactants could be removed from waste waters and whether new compounds produced by industry were amenable to waste water treatment. In order to do this, model units were used representing the two main types of aerobic biological waste water treatment (activated sludge and percolating, or trickling, filtration). It would have been impractical and very costly to distribute each new material and to monitor large-scale treatment plants, even on a local basis.

INITIAL CONSIDERATIONS

Activated sludge units

2. Model activated sludge units have been described ranging in size from 300 ml up to about 2000 ml. Some closely mimicked full-scale plants, having sludge settlement tanks with settled sludge being pumped back to the aeration tank, while others provided no settlement facilities e.g. Swisher (1). The size of the apparatus is a compromise; on the one hand, it must be large enough for successful mechanical operation and for the provision of sufficient volume of samples without affecting the operation, while on the other hand it should not be so large that it demands excessive space and materials.

3. Two forms of apparatus which have been extensively and satisfactorily used are the Husmann units (2) and Porous Pot units (3)(4), first used in the study of surfactants; these are described in this guideline. Others have also been used satisfactorily, e.g. Eckenfelder (5). Because of the relatively high cost and effort of applying this simulation test, simpler and cheaper screening tests, now embodied in 301 A-F were investigated in parallel. Experience with many surfactants and other chemicals has shown that those which passed the screening tests (readily biodegradable) also degraded in the simulation test. Some of those failing the screening tests passed the inherent biodegradability tests (302 A, B) but only some of this latter group were degraded in the simulation test, while those chemicals which failed tests for inherent biodegradability did not degrade in the simulation tests (6)(7)(8).

4. For some purposes simulation tests carried out under a single set of operating conditions are sufficient; the results are expressed as a percentage removal of the test substance or of dissolved organic

carbon (DOC). A description of such a test is given in 303 A. However, unlike the previous 303 A (9), which described only one type of apparatus treating synthetic sewage in the coupled mode using a relatively crude method of sludge wastage, this text offers a number of variations. Alternatives to the type of apparatus, mode of operation, sewage and sludge wastage removal are described. This text closely follows that of the ISO Standard 11733 (10), which was carefully scrutinised during its preparation, though the method has not been subject to a ring test.

5. For other purposes the concentration of the test chemical in the effluent is required to be known more accurately and for this a more extensive method is needed. For example, the sludge wastage rate must be more precisely controlled throughout each day and throughout the period of the test, and units have to be run at a number of wastage rates. For a fully comprehensive method, tests should also be run at two or three different temperatures: such a method is described by Birch (11)(12) and summarised in Annex 6. However, present knowledge is insufficient to decide which of the kinetic models are applicable to the biodegradation of chemicals in waste water treatment and in the aquatic environment generally. The application of Monod kinetics, given in Annex 6 as an example, is limited to substances present at 1 mg/l and above, but in the opinion of some even this remains to be substantiated. Tests at concentrations more truly reflecting those found in waste waters are indicated, in Annex 7, but such tests, and those in Annex 6, are included in Annexes instead of being issued as separate Test Guidelines.

Filters

6. Much less attention has been given to model percolating filters, perhaps because they are more cumbersome and less compact than activated sludge plant models. Gerike et al (13) developed trickling filter units and operated them in the coupled mode (9)(13). These filters were relatively large (height 2 m; volume 60 l) and each required as much as 2 l/h of sewage. Baumann et al (14), simulated trickling filters by inserting polyester "fleece" strips into 1 m tubes (14 mm int. diameter) after the strips had been immersed in concentrated activated sludge for 30 min. The test chemical as sole C source in a mineral salts solution was fed down the vertical tube and biodegradation was assessed from measurements of DOC in the effluent and CO₂ in the issuing gas.

7. Biofilters have been simulated in another way (15); the inner surfaces of rotating tubes, inclined at a small angle to the horizontal, were fed with sewage (about 250 ml/h) with and without the test chemical, and the collected effluents analysed for DOC and/or the specific substance. This method is described in 303 B.

PRINCIPLE OF THE TEST

8. This method is designed to determine the elimination and the primary and/or ultimate biodegradation of water-soluble organic compounds by aerobic micro-organisms in a continuously operated test system simulating the activated sludge process. An easily biodegradable organic medium and the organic test compound are the sources of carbon and energy for the micro-organisms.

9. Two continuously operated test units (activated sludge plants or porous pots) are run in parallel under identical conditions which are chosen to suit the purpose of the test. Normally the mean hydraulic retention time is 6 h and the mean sludge age (sludge retention time) is 6 to 10 days. Sludge is wasted by one of two methods, the test substance is normally added at a concentration of between 10 mg/l dissolved organic carbon

(DOC) and 20 mg/l DOC, to the influent (organic medium) of only one of the units. The second unit is used as a control unit to determine the biodegradation of the organic medium.

10. In frequently taken samples of the effluents, the DOC, preferably, or chemical oxygen demand (COD) is determined, together with the concentration of the test substance (if required) by specific analysis, in the effluent from the unit receiving the test substance. The difference between the effluent concentrations of DOC or COD in the test and control units is assumed to be due to the test substance or its organic metabolites. This difference is compared with the influent concentration of DOC or COD due to the added test substance in order to determine the elimination of the test substance.

11. Biodegradation may normally be distinguished from bioadsorption by careful examination of the elimination-time curve and may usually be confirmed by applying a test for ready biodegradation using an acclimatised inoculum from the unit receiving the test substance.

INFORMATION ON THE TEST SUBSTANCE

12. The purity, water solubility, volatility and adsorption characteristics of the test substance should be known to enable correct interpretation of results to be made. Normally volatile and insoluble substances cannot be tested unless special precautions are taken (see Annex 5). The chemical structure, or at least the empirical formula should also be known in order to calculate theoretical values and/or to check measured values of parameters, e.g. theoretical oxygen demand (ThOD), dissolved organic carbon (DOC) and chemical oxygen demand (COD).

13. Information on the toxicity of the test substance to micro-organisms (see Annex 4) may be useful for selecting appropriate test concentrations and may be essential for the correct interpretation of low biodegradation values.

PASS LEVELS

14. In the original application of this simulation (confirmatory) test to the primary biodegradation of surfactants, a removal of more than 80% of the specific substance is required before the surfactant may be marketed. If the value of 80% is not attained, this simulation (confirmatory) test may be applied and the surfactant may be marketed only if more than 90% of the specific substance is removed. With chemicals in general there is no question of pass/fail and the value of percentage removal obtained can be used in proximate calculations of the probable environmental concentration to be used in hazard assessments posed by chemicals. Results tend to follow an all or nothing pattern. In a number of studies of pure chemicals the percentage removal of DOC was found to be >90% in more than three quarters and >80% in over 90% of chemicals which showed any significant degree of biodegradability.

15. Relatively few chemicals (e.g. surfactants) are present in sewage at the concentrations (about 10 mg C/l) used in this test. Some chemicals may be inhibitory at these concentrations, while the kinetics of removal of others may be different at low concentrations. A more accurate assessment of the degradation could be made by using modified methods, using realistically low concentrations of the test chemical, and the data collected could be used to calculate kinetic constants. However, the necessary experimental techniques

have not yet been fully validated and neither have the kinetic models, which describe the biodegradation reactions, been established (see Annex 7).

REFERENCE SUBSTANCES

16. To ensure that the experimental procedure is being carried out correctly, it is useful occasionally to test substances whose behaviour is known simultaneously when test substances are investigated. Such compounds include adipic acid, 2-phenyl phenol, 1-naphthol, diphenic acid, 1-naphthoic acid, etc. (6)(7)(8).

REPRODUCIBILITY OF TEST RESULTS

17. There have been far fewer reports of studies of simulation tests than of tests for ready biodegradability. Reproducibility between (simultaneous) replicates is good (within 10-15%) for test substances degraded by 80% or more but for less well degraded substances variability is greater. Also, with some borderline substances widely disparate results (e.g. 10%, 90%) have been recorded on different occasions within the 9 weeks allowed in the test.

18. Little difference has been found in results obtained with the two types of apparatus, but some substances have been more extensively and consistently degraded in the presence of domestic sewage than with OECD synthetic sewage.

DESCRIPTION OF THE TEST METHOD

Apparatus

Test system

19. The test system for one test substance consists of a test unit and a control unit; but when only specific analyses are performed (primary biodegradation) only a test unit is required. One control unit can be used for several test units receiving either the same or different test substances. In the case of coupling (Annex 3) each test unit must have its own control unit. The test system may be either an activated sludge plant model, Husmann unit (Annex 1, Figure 1) or a porous pot (Annex 1, Figure 2). In both cases storage vessels of sufficient size for the influents and effluents are needed, as well as pumps to dose the influent, either mixed with solution of the test substance or separately.

20. Each activated sludge plant unit consists of an aeration vessel with a known capacity of about 3 litres of activated sludge and a separator (secondary clarifier) which holds about 1.5 litres; the volumes can, to some extent, be changed by adjusting the height of the separator. Vessels of different sizes are permissible if they are operated with comparable hydraulic loads. If it is not possible to keep the temperature in the test room in the desired range, the use of water-jacketed vessels with temperature controlled water is recommended. An airlift pump or a dosing pump is used to recycle the activated sludge from the separator to the aeration vessel, either continuously or intermittently at regular intervals.

21. The porous pot system consists of an inner, porous cylinder with a conical bottom held in a slightly larger vessel of the same shape, but made of an impervious plastic material. A suitable material for the porous

vessel is porous polyethylene of maximum pore size 90 µm and 2 mm thickness. Separation of the sludge from the treated organic medium is effected by differential passage through the porous wall. Effluents collect in the annular space from where it overflows into the collecting vessel. No settlement occurs and hence there is no sludge return. The whole system may be mounted in a thermostatically controlled water-bath. Porous pots become blocked and could overflow in the initial stages. In such a case, replace the porous liner with a clean one by first siphoning the sludge from the pot into a clean bucket and removing the blocked liner. After wiping out the impervious outer cylinder insert a clean liner and return the sludge to the pot. Any sludge adhering to the sides of the blocked liner is also carefully scraped off and transferred. Clean blocked pots first by using a fine jet of water to remove remaining sludge and by soaking in dilute sodium hypochlorite solution, then in water, followed by thoroughly rinsing with water.

22. For aeration of the sludge in the aeration vessels of both systems, suitable techniques are required, for example sintered cubes (diffuser stones) and compressed air. The air shall be cleaned, if necessary, by passing through a suitable filter and washed. Sufficient air must pass through the system to maintain aerobic conditions and to keep sludge flocs in suspension at all times during the test.

Filtration apparatus or centrifuge

23. Device for filtration of samples with membrane filters of suitable porosity (nominal aperture diameter 0.45 µm) which adsorb soluble organic compounds and release organic carbon to a minimum degree. If filters are used which release organic carbon, wash the filters carefully with hot water to remove leachable organic carbon. Alternatively, a centrifuge capable of producing 40,000 m/s² may be used.

Analytical equipment

24. Apparatus required to determine:

- DOC(dissolved organic carbon) and TOC (total organic carbon), or COD (chemical oxygen demand);
- specific substance, if required;
- suspended solids, pH, oxygen concentration in water;
- temperature, acidity and alkalinity;
- ammonium, nitrite and nitrate, if the test is performed under nitrifying conditions.

Water

25. Tap water, containing less than 3 mg/l DOC. Determine the alkalinity if not already known.

26. Deionised water, containing less than 2 mg/l DOC.

Organic medium

27. Synthetic sewage, domestic sewage or a mixture of both is permissible as the organic medium. It has been shown (8)(12) that the use of domestic sewage alone often gives increased percentage DOC removal and even allows the removal and biodegradation of some chemicals which are not biodegraded when OECD synthetic sewage is used. Also, the constant or intermittent addition of domestic sewage often stabilises the activated sludge, including the crucial ability to settle well. Thus, the use of domestic sewage is recommended. Measure the DOC or COD concentration in each new batch of organic medium. The acidity or alkalinity of the organic medium should be known. The organic medium may require the addition of a suitable buffer (sodium hydrogen carbonate or potassium dihydrogen phosphate) if it is of low acidity or alkalinity, to maintain a pH of about 7.5 ± 0.5 in the aeration vessel during the test. The amount of buffer to be added, and when to add it, has to be decided in each individual case. When mixtures are used either continuously or intermittently, the DOC (or COD) of the mixture must be kept at an approximately constant value, e.g. by dilution with water.

Synthetic sewage

28. Dissolve in each litre of tap water: peptone, 160 mg; meat extract, 110 mg; urea, 30 mg; anhydrous dipotassium hydrogen phosphate (K_2HPO_4), 28 mg; sodium chloride (NaCl), 7 mg; calcium chloride dihydrate ($CaCl_2 \cdot 2H_2O$), 4 mg; magnesium sulphate heptahydrate ($MgSO_4 \cdot 7H_2O$), 2 mg. This OECD synthetic sewage is an example and gives a mean DOC concentration in the influent of about 100 mg/l. Alternatively, use other compositions, with about the same DOC concentration, which are closer to real sewage. If a less concentrated influent is required, dilute the synthetic sewage, for example 1:1, with tap water to obtain a concentration of about 50 mg/l. Such a weaker influent will allow better growth of nitrifying organisms and this modification should be used if the simulation of nitrifying waste water plants is to be investigated. This synthetic sewage may be made up in distilled water in a concentrated form and stored at about 1 °C for up to one week. When needed, dilute with tap water. (This medium is unsatisfactory e.g. nitrogen concentration is very high, relatively low carbon content, but nothing better has been suggested, except to add more phosphate as buffer and extra peptone).

Domestic sewage

29. Use fresh settled sewage collected daily from a treatment works receiving predominantly domestic sewage. It should be collected, prior to primary sedimentation, from the overflow channel of the primary sedimentation tank, or from the feed to the activated sludge plant, and be largely free from coarse particles. The sewage can be used after storage for several days (but generally should not exceed seven days) at about 4 °C, if it is proved that the DOC (or COD) has not significantly decreased (i.e. by less than 20%) during storage. In order to limit disturbances to the system, the DOC (or COD) of each new batch should be adjusted before use to an appropriate constant value, e.g. by dilution with tap water.

Activated sludge

30. Collect activated sludge for inoculation from the aeration tank of a well operated waste water treatment plant or from a laboratory - scale activated sludge unit, treating predominantly domestic sewage.

Stock solutions of test substance

31. For substances of adequate solubility, prepare stock solutions at appropriate concentrations (e.g. 1 to 5 g/l) in deionised water, or in the mineral portion of the synthetic sewage. (for insoluble and volatile substances, see Annex 5). Determine the DOC and total organic carbon (TOC) of the stock solution and repeat the measurements for each new batch. If the difference between the DOC and TOC is greater than 20%, check the water-solubility of the test substance. Compare the DOC or the concentration of the test substance measured by specific analysis of the stock solution with the nominal value, to ascertain whether recovery is good enough (normally >90% can be expected). Ascertain, especially for dispersions, whether or not DOC can be used as an analytical parameter or if only an analytical technique specific for the test substance can be used. Centrifugation of the samples is required for dispersions. For each new batch, measure the DOC, COD or the test compound with specific analysis.

32. Determine the pH of the stock solution. Extreme values indicate that the addition of the substance may have an influence on the pH of the activated sludge in the test system. In this case neutralise the stock solution to obtain a pH of 7 ± 0.5 with small amounts of inorganic acid or base, but avoid precipitation of the test substance.

PROCEDURE

33. The procedure is described for the activated sludge plant units; it has to be slightly adapted for the porous pot system.

Preparation of the inoculum

34. Inoculate the test system at the beginning of the test with either activated sludge or an inoculum containing a low concentration of micro-organisms. Keep the inoculum aerated at room temperature until it is used and use it within 24 h. In the first case, take a sample of activated sludge from the aeration tank of an efficiently operated biological waste water treatment plant, or a laboratory treatment plant, which receives predominantly domestic sewage. If nitrifying conditions are to be simulated, take sludge from a nitrifying waste water treatment plant. Determine the concentration of suspended solids and, if necessary, concentrate the sludge by settling so that the volume added to the test system is minimal. Ensure that the starting concentration of dry matter is about 2.5 g/l.

35. In the second case, use 2 ml/l to 10 ml/l of an effluent from a domestic biological waste water treatment plant as an inoculum. To get as many different species of bacteria as possible, it may be helpful to add inocula from various other sources, for example surface water. In this case, the activated sludge will develop and grow in the test system.

Dosage of organic medium

36. Ensure that influent and effluent containers and tubing from influent vessels and to effluent vessels are thoroughly cleaned to remove microbial growths initially and throughout the test. Assemble the test systems in a room where the temperature is controlled (normally in the range 20-25° C) or use water-jacketed test units. Prepare a sufficient volume of the required organic medium (paragraphs 27-29). Initially fill the aeration vessel and the separator with the organic medium and add the inoculum (paragraphs 34, 35). Start the

aeration such that the sludge is kept in suspension and in an aerobic state and begin dosing the influent and recycling the settled sludge. Dose organic medium out of storage vessels into the aeration vessels (paragraphs 20, 21) of the test and control units and collect the respective effluents in similar storage vessels. To get the normal hydraulic retention time of 6 h, the organic medium is pumped at 0.5 l/h. To confirm this rate, measure the daily amount of organic medium dosed by noting the reduction in volumes of the medium in the storage vessels. Other modes of dosing would be necessary for determining the effects of intermittent release and “shock” loading of chemicals.

37. If the organic medium is prepared for use for a period longer than 1 day, cooling at about 4 °C, or other appropriate methods of conservation are necessary to prevent microbial growth and biodegradation outside the test units (paragraph 29). If synthetic sewage is used, it is possible to prepare, and store at about 4 °C, a concentrated stock solution (e.g. 10-fold the normal concentration, paragraph 28). This stock solution can be well mixed with the appropriate volume of tap water before use; alternatively, it can be pumped directly while the appropriate amount of tap water is pumped separately.

Dosage of test substance

38. Add an appropriate volume of the stock solution of the test substance (paragraph 31) to the storage vessel of the influent or dose it directly with a separate pump into the aeration vessel. The normal mean test concentration in the influent should be between 10 mg/l and 20 mg/l DOC, with an upper concentration of no more than 50 mg/l. If the water-solubility of the test substance is low or if toxic effects are likely to occur, reduce the concentration to 5 mg/l DOC or even less, but only if a suitable specific analytical method is available and performed (dispersed test substances which are poorly soluble in water may be added using special dosing techniques, see Annex 5).

39. Start adding the test substance after a period in which the system has stabilised and is removing DOC of the organic medium efficiently (about 80%). It is important to check that all units are working equally efficiently before the addition of test substance; if they are not, it usually helps to mix the individual sludges and to re-dispense equal volumes to individual units. When an inoculum of (about) 2.5 g/l (dry weight) activated sludge is used, the test substance may be added from the start of the test since directly adding increasing amounts from the beginning has the advantage that the activated sludge may be better able to adapt to the test substance. In whatever manner the test substance is added, it is recommended that the relevant flow rate and/or the volumes in the storage vessel(s) are measured at regular intervals.

Handling of activated sludge

40. The concentration of activated sludge solids normally stabilises between limits during the test, independent of the inoculum used, in the range 1 to 3 g/l (dry weight) depending on the quality and concentration of the organic medium, operating conditions, the nature of the micro-organisms present and the influence of the test substance.

41. Either determine the suspended solids in the aeration vessels at least weekly and discard surplus sludge to maintain the concentration at 1 g/l to 3 g/l (dry weight), or control the mean sludge age at a constant value usually in the range 6 days to 10 days. If, for example, a sludge retention time of 8 days is chosen, remove daily 1/8 of the volume of the activated sludge in the aeration vessel and discard it. Carry this out on a daily basis or, preferably, by means of an automatic intermittently operating pump. Maintaining the concentration of suspended solids constant, or within narrow limits, does not maintain a constant sludge

retention time (SRT), which is the operating variable that determines the value of the concentration of test substance in the effluent.

42. Throughout the test, remove, at least daily, any sludge adhering to the walls of the aeration vessel and the separator so that it is resuspended. Check and clean regularly all tubes and tubing to prevent growth of biofilm. Recycle the settled sludge from the separator to the aeration vessel, preferably by intermittent pumping. No recycling takes place in the porous pot system but ensure that clean inner pots are inserted before the volume in the vessel rises significantly (paragraph 21).

43. Poor settlement and loss of sludge may occur in the Husmann plant units. These may be rectified by employing one or more of the actions, listed below, in parallel in test and control units:

- fresh sludge or flocculant (for example 2 ml/vessel of 50 g/l FeCl_3) could be added at regular intervals, e.g. weekly, but ascertain that no reaction or precipitation of the test substance occurs with FeCl_3 ;
- the air-lift pump could be replaced by a peristaltic pump, thus enabling a sludge recirculation flow which about equals the influent flow to be used and allowing development of an anaerobic zone in the settled sludge (the geometry of the air-lift pump limits the minimum flow rate of returned sludge to be about 12-fold that of the influent);
- sludge could be pumped intermittently from the separator to the aeration vessel (e.g. 5 min. every 2.5 h to recycle 1 l/h to 1.5 l/h);
- a non-toxic, anti-foaming agent at minimal concentration could be used to prevent loss by foaming (e.g. silicone oil);
- air could be passed through the sludge in the separator in short, shock bursts (e.g. 10 sec. every hour);
- the organic medium may be dosed at intervals into the aeration vessel (e.g. 3 min. to 10 min. every hour).

Sampling and analysis

44. At regular intervals measure the dissolved oxygen concentration, the temperature and the pH value of the activated sludge in the aeration vessels. Ensure that sufficient oxygen is always available (>2 mg/l) and that the temperature is kept in the required range (normally 20 °C to 25 °C). Keep the pH at 7.5 ± 0.5 by dosing small amounts of inorganic base or acid into the aeration vessel or into the influent, or by increasing the buffering capacity of the organic medium (see paragraph 27). When nitrification occurs acid is produced, the oxidation of 1 mg N producing the equivalent of about 7 mg CO_3^{--} . The frequency of measuring depends on the parameter to be measured and the stability of the system, and may vary between daily and weekly measurements.

45. Measure the DOC or COD in the influents to the control and test vessels. Measure the test substance concentration in the test influent by specific analysis or estimate it from the concentration in the stock solution (paragraph 31), the volume used and the amount of sewage dosed into the test unit. It is recommended that the concentration of the test substance be calculated in order to reduce the variability of the concentration data.

46. Take suitable samples from the collected effluent (e.g. 24 h composites) and filter through a membrane of pore size 0.45 μm or centrifuge them at about 40,000 m/s^2 for about 15 min. Centrifuging should

be used if filtering is difficult. Determine DOC or COD at least in duplicate to measure ultimate biodegradation and, if required, primary biodegradation by an analysis specific for the test substance.

47. The use of COD may give rise to analytical problems at low concentrations and is therefore recommended only if a sufficiently high test concentration (about 30 mg/l) is used. Also, for strongly adsorbing substances, it is recommended that the amount of adsorbed substance in the sludge be measured using an analytical technique specific for the test substance.

48. The frequency of sampling depends on the expected duration of the test. A recommended frequency is three times per week. Once the units are operating efficiently, allow from 1 week to a maximum of 6 weeks after the test substance has been introduced, for adaptation to reach a steady state. Preferably obtain at least 15 valid values in the plateau phase (paragraph 59), normally lasting 3 weeks, for the evaluation of the test result. The test may be completed if a sufficient degree of elimination is reached (e.g. >90%) and these 15 values, which represent analyses carried out each weekday over 3 weeks, are available. Normally, do not exceed a test duration of more than 12 weeks after addition of the test substance.

49. If the sludge nitrifies and if the effects of the test substance on nitrification are to be studied, analyse samples from the effluent of the test and control units at least once per week for ammonium and/or nitrite plus nitrate.

50. All analyses should be performed as soon as possible, especially the nitrogen determinations. If analyses have to be postponed, store the samples at about 4 °C in the dark in full, tightly stopped bottles. If samples have to be stored for more than 48 h, preserve them by deep-freezing, acidification (e.g. 10 ml/l of a 400 g/l solution of sulphuric acid) or by addition of a suitable toxic substance (e.g. 20 ml/l of a 10 g/l solution of mercury (II) chloride). Ensure that the preservation technique does not influence results of analysis.

Coupling of test units

51. If coupling is to be used (Annex 3), daily exchange the same amount of activated sludge (150 ml to 1500 ml for aeration vessels containing 3 litres of liquor) between the aeration vessels of the test unit and its control unit. If the test substance adsorbs strongly onto the sludge, change only the supernatant of the separators. In both cases use a correction factor to calculate the test results (paragraph 55).

DATA AND REPORTING

Treatment of results

52. Calculate the percentage of DOC or COD elimination of the test substance for each timed assessment, using the equation:

$$D_t = \frac{C_s - (E - E_0)}{C_s} \times 100$$

where D_t = % elimination of DOC or COD at time t

- C_s = DOC or COD in the influent due to the test substance, preferably estimated from the stock solution (mg/l)
 E = measured DOC or COD value in the test effluent at time t (mg/l)
 E_o = measured DOC or COD value in the control effluent at time t (mg/l)

53. The degree of DOC or COD elimination of the organic medium in the control unit is helpful information in assessing the biodegradative activity of the activated sludge during the test. Calculate the percentage elimination from the equation:

$$D_B = \frac{C_M - E_o}{C_M} \times 100$$

- where D_B = % elimination of DOC or COD of the organic medium in the control unit at time t
 C_M = DOC or COD of the organic medium in the control influent (mg/l)

Optionally, calculate the percentage elimination DOC or COD due to the organic medium plus test substance in the test unit from the equation:

$$D_T = \frac{C_T - E}{C_T} \times 100$$

- where D_T = % elimination of total test influent DOC or COD
 C_T = DOC or COD of total test influent or calculated from stock solutions (mg/l)

54. Calculate the removal of the test substance if measured with a specific analytical method at each time assessment from equation:

$$D_{ST} = \frac{S_i - S_e}{S_i} \times 100$$

- where D_{ST} = % primary elimination of test substance at time t
 S_i = measured or estimated test substance concentration in the test influent (mg/l)
 S_e = measured test substance concentration in test effluent at time t (mg/l)

55. If the coupling mode has been used, compensate the dilution of the test substance in the aeration vessel by the sludge exchange using a correction factor (see Annex 3). If a mean hydraulic retention time of 6 h and an exchange of half of the volume of the activated sludge in the aeration vessel have been used, the determined daily elimination values (D_t , paragraph 52) have to be corrected to obtain the true degree of elimination, D_{tc} , of the test substance from the equation:

$$D_{tc} = \frac{4D_t - 100}{3}$$

Expression of test results

56. Plot the percentage elimination D_t (or D_{tc}) and D_{st} , if available, versus time (see Annex 2). From the shape of the elimination curve of the test substance (*per se* or as DOC) some conclusions may be drawn about the removal process.

Adsorption

57. If a high DOC elimination of the test substance is observed from the beginning of the test, the test substance is probably eliminated by adsorption onto the activated sludge solids. It is possible to prove this by determining the adsorbed test substance by specific analysis. It is not usual for the elimination of DOC of adsorbable substances to remain high throughout the test; normally, there is a high degree removal initially which gradually falls to an equilibrium value. If, however, the adsorbable test substance was able to cause acclimation of the microbial population in some way or other, the DOC elimination of the test substance would subsequently increase and reach a high plateau value.

Lag phase

58. As in static, screening tests, many test substances require a lag phase before full biodegradation occurs. In the lag phase, acclimation or adaptation of the degrading bacteria takes place with almost no removal of the test substance; then the initial growth of these bacteria occurs. This phase ends and the degradation phase is taken to begin when about 10% of the initial amount of test substance is removed (after allowing for adsorption, if it occurs). The lag phase is often highly variable and poorly reproducible.

Plateau phase

59. The plateau phase of an elimination curve in a continuous test is defined as that phase in which the maximum degradation takes place. The plateau phase should be at least 3 weeks and have about 15 measured valid values.

Mean degree of elimination of test substance

60. Calculate the mean value from the elimination values (D_t) of the test substance at the plateau phase. Rounded to the nearest whole number (1%), it is the degree of elimination of the test substance. It is also recommended to calculate the 95% confidence interval of the mean value.

Elimination of organic medium

61. Plot the percentage of elimination of the DOC or COD of the organic medium in the control unit (D_B) versus time. Indicate the mean degree of elimination in the same way as for the test substance (paragraph 60).

Indication of biodegradation

62. If the test substance does not adsorb significantly on to activated sludge and the elimination curve has a typical shape of a biodegradation curve with lag, degradation and plateau phases (paragraphs 58, 59), the

measured elimination can safely be attributed to biodegradation. If a high initial removal has taken place, the simulation test cannot differentiate between biological and abiotic elimination processes. In such cases, and in other cases where there is any doubt about biodegradation (e.g. if stripping takes place), analyse adsorbed test substances or perform additional static biodegradation tests based on parameters clearly indicating biological processes. Such tests are the oxygen uptake methods (301 C, 301 D and 301 F) or a test with measurement of carbon dioxide production (301 B) or the ISO Headspace method (16), using a pre-exposed inoculum from the simulation test. If both the DOC removal and specific substance removal have been measured, significant differences (the former being lower than the latter) between the percentages removed indicate the presence in the effluents of intermediate organic products which may be more difficult to degrade than the parent compound.

Validity of test results

63. Information on the normal biodegradation behaviour of the inoculum is achieved if the degree of elimination of the organic medium (paragraph 53) in the control unit is determined. Consider the test to be valid if the degree of DOC or COD elimination in the control unit(s) is >80% after two weeks and no unusual observations have been made.

64. If a readily biodegradable (reference) substance has been used, the degree of biodegradation (D, paragraph 52) should be >90%.

65. If the test is performed under nitrifying conditions, the mean concentration in the effluents should be <1 mg/l ammonia-N and <2 mg/l nitrite-N.

66. If these criteria (paragraphs 63-65) are not met, repeat the test using an inoculum from a different source, test a reference substance, and review all experimental procedures.

Test Report

67. The test report must include the following:

Test substance:

- identification data;
- physical nature and, where relevant, physical-chemical properties.

Test conditions:

- type of test system; any modifications for testing insoluble and volatile compounds;
- type of organic medium;
- proportion and nature of industrial waste waters in sewage, if known;
- inoculum, nature and sampling site(s), concentration and any pre-treatment;
- test substance stock solution: DOC and TOC content; how prepared, if suspension; test concentration used; reasons if outside range of 10 - 20 mg DOC/l; method of addition; date first added; any changes;
- mean sludge age and mean hydraulic retention time; method of sludge wastage; methods of overcoming bulking, loss of sludge, etc.;

- analytical techniques employed;
- test temperature;
- qualities of the sludge-bulking, sludge volume index (SVI), mixed liquor suspended solids (MLSS);
- any deviations from standard procedures and any circumstances which may have affected results.

Test results:

- all measured data (DOC, COD, specific analyses, pH, temperature, oxygen concentration, suspended solids, N compounds, if relevant);
- all calculated values of D_t (or D_{tc}), D_B , D_{St} obtained in tabular form and the elimination curves;
- information on lag and plateau phases, test duration, the degree of elimination of the test compound and that of the organic medium in the control unit, together with statistical information and statements of biodegradability and validity of the test;
- discussion of results.

LITERATURE

- (1) Swisher RD "Surfactant Biodegradation", 2nd Edn. Marcel Dekker Inc. New York, 1085 pp (1987).
- (2) German Government (1962) Ordinance of the degradability of detergents in washing and cleaning agents. Bundesgesetzblatt, Pt.1 No.49:698-706.
- (3) Painter H A and King E F (1978,a) WRc porous-pot method for assessing biodegradability. Technical Report No.70, Water Research Centre, Medmenham, UK.
- (4) Painter H A and King E F (1978,b) The effect of phosphate and temperature on growth of activated sludge and on biodegradation of surfactants. Wat. Res., 12,909-915.
- (5) Eckenfelder, W.W (19) [to come from USEPA].
- (6) Gerike, P and Fischer, W K (1979) A correlation study of biodegradability determinations with various chemicals in various tests. Ecotox. Env. Saf., 3,157-173.
- (7) Gerike, P and Fischer, W K (1981), as (6), II Additional results and conclusions. Ecotox. Env. Saf., 5, 45-55.
- (8) Painter, H A and Bealing, D (1989) Experience and data from the OECD activated sludge simulation test. pp 113-138, In: Laboratory tests for simulation of water treatment processes. CEC Water Pollution Report 18. Eds. Jacobsen BN, Muntau, H, Angeletti,G.
- (9) OECD Test Guideline 303A, Paris (1981).

- (10) International Organization for Standardization, ISO Standard 11,733. Evaluation of the elimination and biodegradability of organic compounds in an aqueous medium - activated sludge simulation test (1995).
- (11) Birch, R R (1982) The biodegradability of alcohol ethoxylates. XIII Jornado Com. Espanol. Deterg., 33-48.
- (12) Birch, R R (1984) Biodegradation of nonionic surfactants. J.A.O.C.S., 61 (2) 340-343.
- (13) Gerike P, Fischer W K and Holtmann W (1980) Biodegradability determinations in trickling filter units compared with the OECD confirmatory test. Wat.Res., 14, 753-758.
- (14) Baumann U, Kuhn G and Benz M. (1998) Einfache Versuchsanordnung zur Gewinnung gewässerökologisch relevanter Daten, UWSF - Z. Umweltchem. Ökotox., 10, 214-220.
- (15) Her Majesty's Stationery Office (1982) Assessment of biodegradability. Methods for the examination of waters and associated materials. pp. 91-98 ISBN 011 751661 9.
- (16) ISO 14,593 (1998) Water Quality - Evaluation in an aqueous medium of the ultimate biodegradability of organic compounds. Method by the analysis of inorganic carbon in sealed vessels.

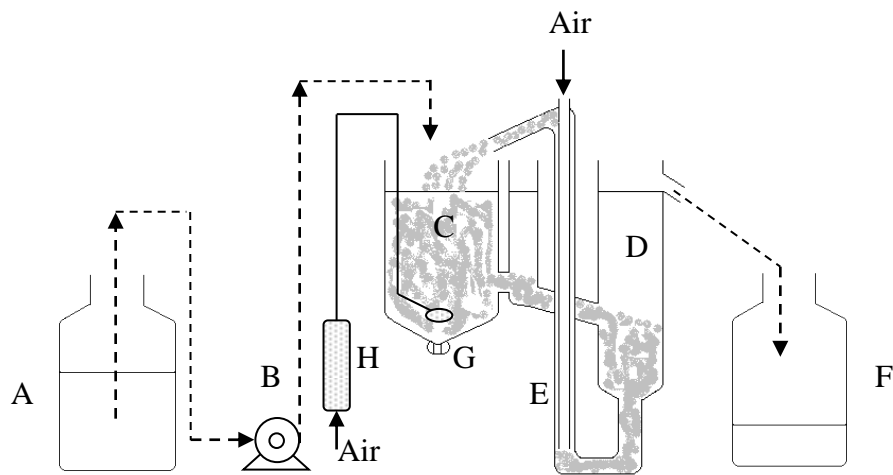
ANNEX 1Figure 1: Equipment used for assessment of biodegradabilityHusmann unit

- | | |
|------------------------------------|----------------------|
| A. Storage vessel | E. Air lift pump |
| B. Dosing pump | F. Collection vessel |
| C. Aeration chamber (3 l capacity) | G. Aerator |
| D. Settling vessel | H. Air flow meter |

Figure 2: Equipment used for assessment of biodegradability

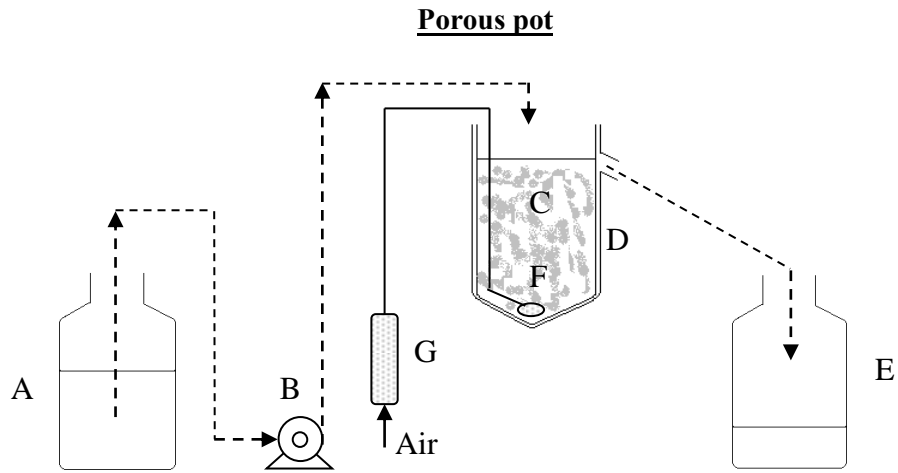

- | | |
|---|--|
| <ul style="list-style-type: none"> A. Storage vessel B. Dosing pump C. Porous aeration vessel D. Outer impermeable vessel | <ul style="list-style-type: none"> E. Collection vessel F. Diffuser G. Air flow meter |
|---|--|

ANNEX 1 (continued)

Figure 3: Details of 3 litre porous pot aeration vessel

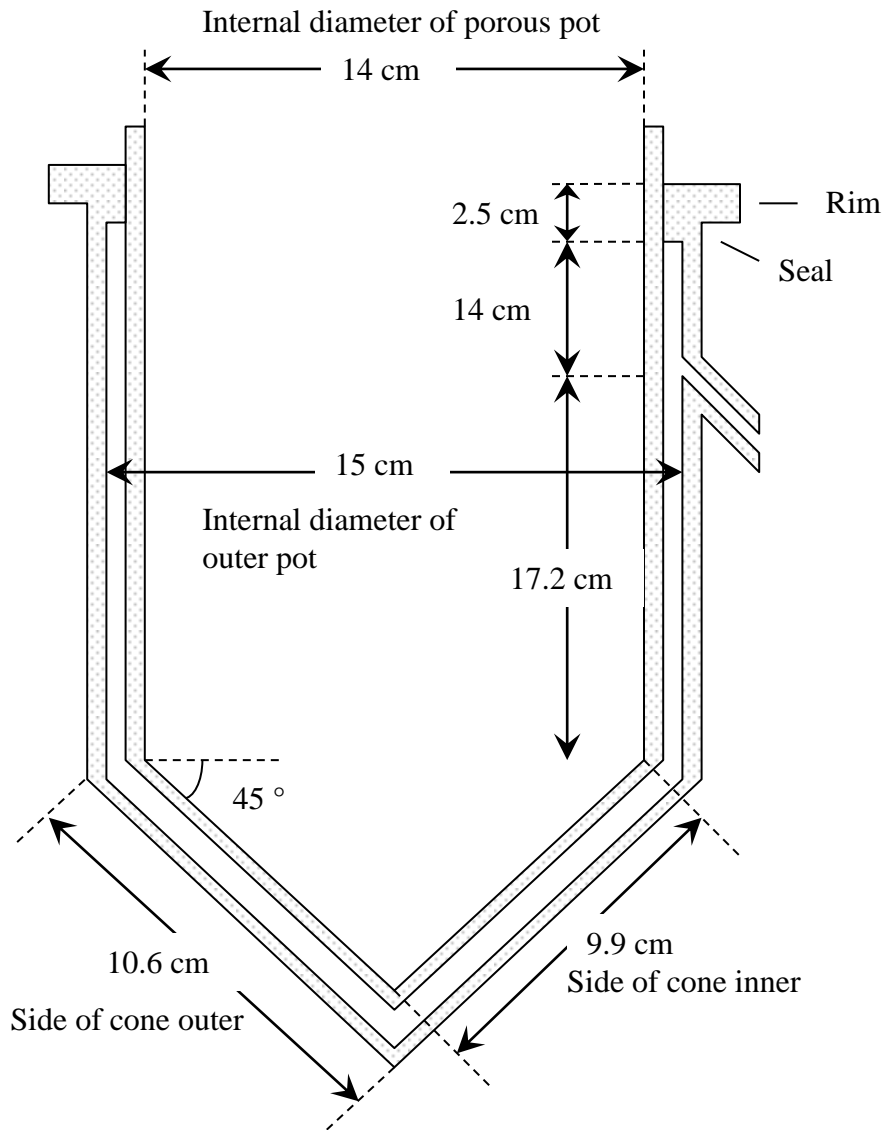

ANNEX 2

EXAMPLE OF AN ELIMINATION CURVE

Polyethylene glycol 400
 Test Concentration 20 mg/l DOC

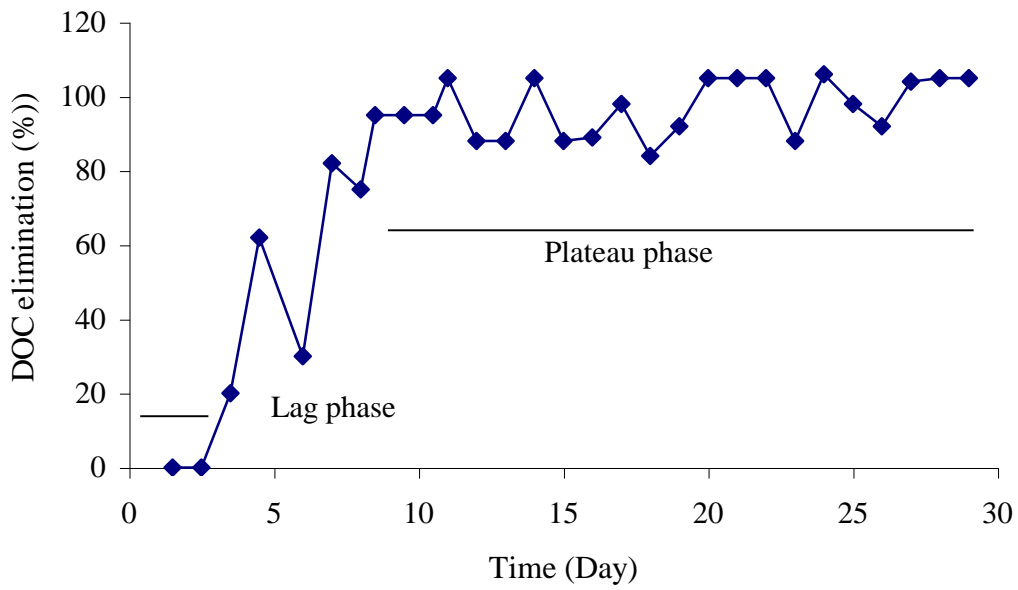

ANNEX 3

[INFORMATIVE]

COUPLING OF THE TEST UNITS

In order to try to equalise the microbial populations in sludges in a test unit, receiving sewage plus a test substance, and in a control unit, receiving only sewage, a daily interchange of sludge was introduced (1). The procedure was called coupling and the method is known as coupled units. Coupling was initially performed using Husmann activated sludge units but it has also been done with Porous Pot units (2)(3). No significant differences in results were found as between non-coupled and coupled units, whether Husmann or Porous Pot so there is no advantage in expending the time and energy needed in coupling the units.

Sludge exchanges can give the appearance of quite a considerable removal, since some of the test substance is transferred and the concentrations of test substance in the test and control effluents become more nearly equal. Thus, correcting factors have to be used which depend on the fraction exchanged and the mean hydraulic retention time. More details of the calculation have been published (1).

Calculate the corrected DOC or COD elimination degree using the general formula:

$$D_{ic} = (D_t - 100 \cdot a \cdot r / 12) / (1 - a \cdot r / 12) \%$$

where

- D_{ic} = corrected % DOC or COD elimination
- D_t = determined % DOC or COD elimination
- a = interchange fraction of the volume of the activated sludge units
- r = mean hydraulic retention time (h)

If, for example, half of the volume of the aeration tank is exchanged ($a = 0.5$) and the mean hydraulic retention time is 6h, the correction formula is:

$$D_{ic} = \frac{4D_t - 100}{3}$$

References

- (1) Fischer W., Gerike P., Holtmann W. (1975). Biodegradability Determinations via Unspecific Analyses (Chemical Oxygen Demand, DOC) in Coupled Units of the OECD Confirmatory Test. I The test. *Wat. Res.*, 9, 1131-1135.
- (2) Painter H.A., Bealing D.J. (1989). Experience and Data from the OECD Activated Sludge Simulation Test. pp. 113-138. In: *Laboratory Tests for Simulation of Water Treatment Processes CEC Water Pollution Report 18*. Eds. Jacobsen BN, Muntau H, Angeletti G.
- (3) Painter H.A., King E.F. (1978). *Water Research Centre Porous Pot Method for Assessing Biodegradability*. Technical Report TR70, Water Research Centre, Stevenage, UK.

ANNEX 4**EVALUATION OF INHIBITION OF THE ACTIVATED SLUDGE
PROCESS BY TEST SUBSTANCES**

1. A chemical (or a waste water) may not be degraded or removed in the simulation test and may even have an inhibitory effect on the sludge micro-organisms. Other chemicals are biodegraded at low concentrations but are inhibitory at higher concentration (hormesis). Inhibitory effects may have been revealed at an earlier stage or may be determined by applying a toxicity test, using an inoculum similar to or identical with that used in the simulation test (Reynolds et al.). Such methods are inhibition of oxygen uptake (OECD Guideline 209 and ISO Standard 8192) or inhibition of growth of sludge organisms (ISO 15522).
2. In the simulation test any inhibition will be manifest by the difference in dissolved organic carbon (DOC) or chemical oxygen demand COD between the effluent from the test vessel and that from the control being greater than the DOC added as test substance. Expressed in another way, the percentage removal of DOC (and biochemical oxygen demand BOD, chemical oxygen demand COD, and/or NH_4^+) of the organic medium on treatment will be decreased by the presence of the test substance. If this occurs, the test should be repeated reducing the concentration of the test substance until a level is reached at which no inhibition occurs and perhaps further reducing the concentration until the test substance is biodegraded. However, if the test substance (or waste water) has adverse effects on the process at all concentrations tested, the indications are that the substance is difficult, if not impossible, to treat biologically, but it may be worth repeating the test with activated sludge from a different source and/or subjecting the sludge to a more gradual acclimation.
3. Conversely, if the test substance is bioeliminated at the first attempt in the simulation test, its concentration should be increased if it is required to be known whether the substance could be inhibitory.
4. It should be remembered in trying to determine degrees of inhibition that the activated sludge population can change, so that with time the micro-organisms may develop a tolerance towards an inhibitory substance.

5. Calculation of degree of inhibition:

The overall percentage removals R_o , of BOD, DOC, COD etc., for the test and control units can be calculated from:

$$R_o = 100 (I - E) / I \%$$

where: I = influent concentration of BOD, DOC, COD etc, for test or control vessels (mg/l)
E = respective effluent concentrations (mg/l).

I and E must be corrected for the DOC due to the test compound in the test units, otherwise the calculations of percentage inhibition will be incorrect.

The degree of inhibition caused by the presence of the test material can be calculated from:

$$\% \text{ inhibition} = 100 (R_c - R_t) / R_c$$

where: R_c = percentage removal in the control vessels
 R_t = percentage removal in the test vessels

References

Reynolds, L. et al. (1987). Evaluation of the toxicity of substances to be assessed for biodegradability. *Chemosphere*, 16, 2259.

OECD 209 (1984). Activated sludge, Respiration Inhibition Test. OECD Guidelines for Testing of Chemicals.

ISO 15522 (1999). Water Quality - Determination of the inhibitory effect of water constituents on activated sludge microorganisms.

ANNEX 5**POORLY WATER-SOLUBLE TEST SUBSTANCES - VOLATILE SUBSTANCES****Poorly water soluble substances**

Few reports seem to have been published on subjecting poorly water-soluble and insoluble chemicals to tests simulating waste water treatment (1)(2)(3).

There is no single method of dispersal of the test material which is applicable to all insoluble chemicals. Two of the four types of method described in ISO 10634 (4) would seem to be suitable for attempting to disperse test substances for simulation testing; they are the use of emulsifying agents and/or of ultrasonic energy. The stability over at least 24h periods of the resulting dispersion should be established. Suitably stabilised dispersions, contained in a constantly stirred reservoir (paragraph 38), would then be dosed to the aeration tank separately from the domestic (or synthetic) sewage.

If the dispersions are stable, investigate how the test substance can be determined in the dispersed form. It is unlikely that DOC will be suitable, so that a specific analytical method for the test substance would have to be established which could be applied to effluents, effluent solids and activated sludge. The fate of the test substance in the simulation of the activated sludge process would then be determined in liquid and solid phases. Thus, a "mass balance" would be established to decide whether the test substance had been biodegraded. However, this would indicate only primary biodegradation. Demonstration of ultimate biodegradation should be attempted by applying a respirometric test for ready biodegradability (301 B, C or F) using as inoculum sludge exposed to the test substance in the simulation test.

Volatile chemicals

The application of waste water treatment simulations to volatile substances is both debatable and problematic. As with poorly water-soluble test substances, very few reports seem to have been published describing simulation tests using volatile substances. A conventional type of complete-mixing apparatus is adapted by sealing the aeration and settling tanks, measuring and controlling the air flow using flow-meters and passing the exit gas through traps to collect volatile organic matter. In some cases, a vacuum pump is used to draw the exit gas through a 'cold' trap or a purge-trap containing Tenax and silica gel for gas-chromatographic analyses. The test substance present in the trap can be determined analytically.

The test is carried out in two parts. The units are first operated without sludge but with the synthetic waste water plus test substance being pumped into the aeration tank. Influent, effluent and exit gas samples are collected and analysed for the test substance for a few days. From the data collected, the percentage (R_{vs}) of the test material stripped from the system may be calculated.

Then the normal biological test (with sludge) is performed under operating conditions identical to those in the stripping study. DOC or COD measurements are also made to check that the units are performing efficiently. Occasional analyses are made to determine the test substance in the influent, effluent and exit gas in the first part of the test; after acclimation more frequent analyses are made. Again, from the data in the

steady state, the percentage of removal of the test substance from the liquid phase by all processes (R_T) (physical and biological) may be calculated, as well as the proportion (R_V) stripped from the system.

Calculation:

- (a) In the non-biological test, the percentage (R_{VP}) of the test material stripped from the system may be calculated from:

$$\% R_{VP} = \frac{S_{VP}}{S_{IP}} \cdot 100$$

where R_{VP} = removal of test substance by volatilisation (%),
 S_{VP} = test substance collected in trap expressed as equivalent concentration in liquid phase (mg/l),
 S_{IP} = test substance concentration in influent (mg/l).

- (b) In the biological test, the percentage (R_V) of the test material stripped from the system may be calculated from:

$$\% R_V = \frac{S_V}{S_I} \cdot 100$$

where R_V = removal of test substance by volatilisation in biological test (%),
 S_V = test substance collected in trap in biological test, expressed as equivalent concentration in liquid influent (mg/l),
 S_I = test substance concentration in influent (mg/l).

- (c) In the biological test, the percentage (R_T) of the test substance removed by all processes is given by:

$$R_T \% = 1 - \frac{S_E}{S_I} \cdot 100$$

where S_E = concentration of test substance in the (liquid) effluent (mg/l).

- (d) Thus, the percentage (R_{BA}) removed by biodegradation plus adsorption can be calculated from:

$$\% R_{BA} = (R_T - R_V)$$

Separate tests should be carried out to determine whether the test substance is adsorbed; if it is then a further correction may be made.

- (e) A comparison between the proportion of test substance stripped from the biological (R_V) and non-biological test (R_{VP}) systems indicates the overall effect that biological treatment has had on the emission of the test substance into the atmosphere.

Example: Benzene

Sludge retention time = 4 days

A synthetic sewage; retention time = 8h

$$\begin{aligned}S_{IP} &= S_I = 150 \text{ mg/l} \\S_{VP} &= 150 \text{ mg/l} \quad (S_{EP} = 0) \\S_V &= 22.5 \text{ mg/l} \\S_E &= 50 \text{ } \mu\text{g/l}\end{aligned}$$

Thus, $R_{VP} = 100\%$, $R_V = 15\%$
 $R_T = 100\%$ and $R_{BA} = 85\%$.

Benzene was assumed not to be adsorbed onto sludge.

References

- (1) Horn J.A., Moyer J.E., Hale J.H. (1970). Biological degradation of tertiary butyl alcohol. Proc. 25th Ind. Wastes Conference Purdue Univ., 939-854.
- (2) Pitter P., Chudoba J. (1990). Biodegradability of organic substances in the aquatic environment. CRC Press. Boston, USA.
- (3) Stover E.L, Kincannon D.F. (1983). Biological treatability of specific organic compounds found in chemical industry waste waters. J. Wat. Pollut. Control Fed., 55, 97.
- (4) ISO 10634 (1995) Water Quality - Guidance for the preparation and treatment of poorly water-soluble organic compounds for the subsequent evaluation of their biodegradability in an aqueous medium.

ANNEX 6**EFFECTS OF SLUDGE RETENTION TIME (SRT) ON TREATABILITY OF CHEMICALS**INTRODUCTION

1. The method described in the main text was designed to ascertain whether the chemicals tested (usually those known to be inherently, but not readily, biodegradable) can be biodegraded within the limits imposed in waste water treatment plants. The results are expressed in terms of percentage removal and percentage biodegradation. The conditions of operation of the activated sludge units and choice of influent allow rather wide variations in concentration of the test chemical in the effluent. Tests are carried out at only one nominal concentration of sludge solids or one nominal sludge retention time (SRT) and the sludge wastage regimes described can cause the value of SRT to vary considerably during the test, both from day to day and during a day.

2. In this variant (1)(2) the SRT is controlled within much narrower limits throughout each 24h period (just as happens on the large-scale) which results in a more constant concentration in effluents. Domestic sewage is recommended since it gives more consistent and higher percentage removals. Also, the effects of a number of SRT values are investigated and in a more detailed study the effects of a range of temperatures on effluent concentration may be determined.

3. There is no general agreement yet on which kinetic models operate when chemicals bio-degrade under conditions in waste water treatment. The Monod model of bacterial growth and substrate utilisation was chosen (1)(2) to be applied to the data collected, since the method was intended to be applied only to chemicals produced in high tonnages, resulting in concentrations in sewage of above 1 mg/l. The validity of the simplified model and the assumptions made was established using a series of alcohol ethoxylates having varying degrees of primary biodegradability (2)(3).

Note. This variant method follows closely much of the text of 303 A and only those details which differ are given hereafter.

PRINCIPLE OF THE TEST

4. Activated sludge porous-pot units, designed to facilitate the (almost) continuous wastage of mixed liquor allowing very precise control of the sludge retention time (SRT, or θ_s), are operated in the non-coupled mode over a range of SRTs and, optionally, over a range of temperatures. The retention time is usually 2 to 10 days and the temperature between 5 and 20°C. Sewage, preferably domestic, and a solution of the test substance are dosed separately to the units at rates to give the required sewage retention time (3 to 6 hours) and the required concentration of test substance in the influent. Control units receiving no test substance are operated in parallel for comparative purposes.

5. Other types of apparatus can be used but great care should be exercised to ensure that good control of SRT is achieved. For example, when using plants which incorporate a settler, allowance for loss of solids via the plant effluent may be necessary. Further, special precautions to avoid errors due to variation in the quantity of sludge in the settler should also be taken.

6. The units are operated at each selected set of conditions and, after equilibrium has been reached, the average steady state concentrations in the effluents of test substance and, optionally, DOC are obtained over a period of about three weeks. Besides assessing the percentage removal of test substance and, optionally, DOC, the relationship between plant-operating conditions and the concentration in the effluent is expressed in graphical form. From this tentative kinetic constants may be calculated and the conditions under which the test substance can be treated may be predicted.

INFORMATION ON THE TEST SUBSTANCE

7. 303 A, paragraphs 12 and 13 apply.

PASS LEVELS

8. 303 A, paragraphs 14 and 15 apply.

REFERENCE TEST SUBSTANCE

9. 303 A, paragraph 16 apply.

REPRODUCIBILITY OF TEST RESULTS

10. 303 A, paragraphs 17 and 18 apply.

DESCRIPTION OF THE METHOD

Apparatus

11. A suitable unit is the modified porous pot system (Appendix 1). It consists of an inner vessel (or liner) constructed from porous polypropylene of 3.2 mm thickness and pore size of approximately 90 µm, the joint being butt-welded. (This makes a more robust unit than that described in paragraph 21, 303 A). The liner is fitted into an impervious polyethylene outer vessel, which consists of two parts: a circular base in which holes are bored to accommodate two air lines and a sludge-wastage line, and an upper cylinder which screws on to the base and which has an outlet placed so as to give a known volume (3 l) in the porous pot vessel. One of the air lines is fitted with a diffuser stone and the other is open-ended and set at right-angles to the stone in the pot. This system produces the necessary turbulence to ensure that the contents of the pot are completely mixed, as well as providing concentrations of dissolved oxygen greater than 2 mg/l.

12. The appropriate number of units are maintained at controlled temperatures in the range of 5 to 20°C ($\pm 1^\circ\text{C}$), either in water baths or in constant temperature rooms. Pumps are required to dose to the aeration vessels the solution of the test substance and settled sewage at the required rates (0-1.0 ml/min and 0-25 ml/min, respectively) and a third pump to remove waste sludge from the aeration vessels. The necessary

very low flow-rate of waste sludge is achieved by using a pump set at a higher rate and operated intermittently by the use of a timer-switch, e.g. operating for 10 seconds per min, pump delivery rate of 3ml/min yielding a wastage rate of 0.5 ml/min.

Filtration apparatus or centrifuge

13. 303 A, paragraph 23 apply.

Analytical equipment

14. 303 A, paragraph 24 apply.

Water

15. 303 A, paragraphs 25 and 26 apply.

Organic medium

16. 303 A, paragraph 27 apply.

Synthetic sewage

17. 303 A, paragraph 28 apply.

Domestic sewage

18. 303 A, paragraph 29 apply.

Activated sludge

19. 303 A, paragraph 30 apply.

Stock solutions of test substance

20. 303 A, paragraphs 31 and 32 apply.

PROCEDURE

Preparation of the inoculum

21. 303 A, paragraph 34 apply only - use activated sludge (about 2.5 g/l).

Number of test units

22. For a simple test, ie. to measure percentage removal, only a single SRT is required, but in order to acquire data necessary to calculate tentative kinetic constants 4 or 5 SRT values are required. Values between

2 and 10 days are usually chosen. Practically, it is convenient to perform a test at 4 or 5 SRTs simultaneously at one temperature; in extended studies the same SRT values, or perhaps a different range of values, are used at other temperatures within the range 5 to 20°C. For primary biodegradation (the main use), only one unit per set of conditions is normally required. However, for ultimate biodegradability a control unit is required, for each set of conditions, which receives sewage but not test substance. If the test substance is thought to be present in the sewage used, it would be necessary to use control units when assessing primary biodegradation, and making the necessary correction in the calculations.

Dosage of organic medium and test substance

23. 303 A, paragraphs 36 to 39 apply, but note that the test substance solution is dosed separately and that various sludge wastage rates are used. Also monitor and adjust, if necessary, to within $\pm 10\%$, the flow-rates of influents, effluents and sludge wastage frequently, e.g. twice per day. If difficulties are encountered in the analytical methods when domestic sewage is used, carry out the test with synthetic sewage, but it must be assured that different media give comparable kinetic data.

Handling of activated sludge units

24. 303 A, paragraphs 40 to 43 apply, but control SRT only by “constant” wastage of sludge.

Sampling and analysis

25. 303 A, paragraphs 44 to 50 apply, except that the concentration of the test substance is to be determined and DOC determined optionally; COD should not be used.

DATA AND REPORTING

Treatment of results

26. 303 A, paragraphs 52 to 54 apply.

Expression of test results

27. 303 A, paragraphs 56 to 62 apply.

Calculation of kinetic constants

28. It is more realistic to quote the mean steady - state concentration of the test substance in the effluent and to describe how this varies with plant-operating conditions than to quote percentage primary biodegradation. This can be done by consideration of equation (6) in Appendix 2, which can yield values for K_S , μ_m and θ_{SC} , the critical sludge retention time.

(Alternatively, approximate values of K_S and μ_m may be obtained using a simple computer program to fit the theoretical curve calculated from equation 2 (Appendix 2) to the experimental values obtained. Although any given solution will not be unique, a reasonable approximation of K_S and μ_m can be obtained.)

Variability of results

29. It is common experience that variable values of kinetic parameters for individual chemicals are obtained. It is thought that the conditions under which the sludge has been grown, as well as the conditions prevailing in the test used (as in paragraph 5 and in other tests), have a large effect on the resulting values. One aspect of this variability has been discussed by Grady et al (4), who have suggested that the terms “extant” and “intrinsic” should be applied to two extreme conditions representing the limits of physiological state a culture may attain during a kinetic experiment. If the state is not allowed to change during the test, the kinetic parameter values reflect the conditions in the environment from which the micro-organisms were taken; these values are called “extant” or currently existing. At the other extreme, if conditions in the test are such as to permit the full development of the protein-synthesizing system allowing maximum possible growth rate, the kinetic parameters obtained are said to be “intrinsic”, and are dependent only on the nature of the substrate and the types of bacteria in the culture. As a guide, extant values will be obtained by keeping the ratio of concentration of substrate to competent micro-organisms (S_0/X_0) low, e.g. 0.025, and intrinsic values arise when the ratio is high e.g. at least 20. In both cases, S_0 should equal or exceed the relevant value of K_s , the half-saturation constant.

30. Variability and other facets of biodegradation kinetics were discussed at a recent SETAC workshop (5). From such studies, reported and projected, a clearer view of kinetics operating in waste water treatment plants should be forth-coming to enable a better interpretation of existing data to be made, as well as to suggest more relevant designs for future test guidelines.

References

- (1) Birch R R (1982) The biodegradability of alcohol ethoxylates. XIII Jornado Com. Espanol Deterg., 33-48.
- (2) Birch R R (1984) Biodegradation of nonionic surfactants. J.A.O.C.S., 61(2) 340-343.
- (3) Birch R R (1991) Prediction of the fate of detergent chemicals during sewage treatment. J. Chem. Tech. Biotechnol., 50, 411-422.
- (4) Grady, CPL. Smets, BF. and Barbeau DS. (1996). Variability in kinetic parameter estimates: A review of possible causes and a proposed terminology. Wat. Res., 30 (3) 742-748
- (5) Biodegradation kinetics: Generation and use of data for regulatory decision making (1997). Workshop at Port Sunlight, UK. Eds. Hales, SG. Feitjel, T. King, H. Fox, K. and Verstraete, W. 4-6th Sept. 1996. SETAC- Europe, Brussels.

Appendix 1

Porous Pot with SRT Control

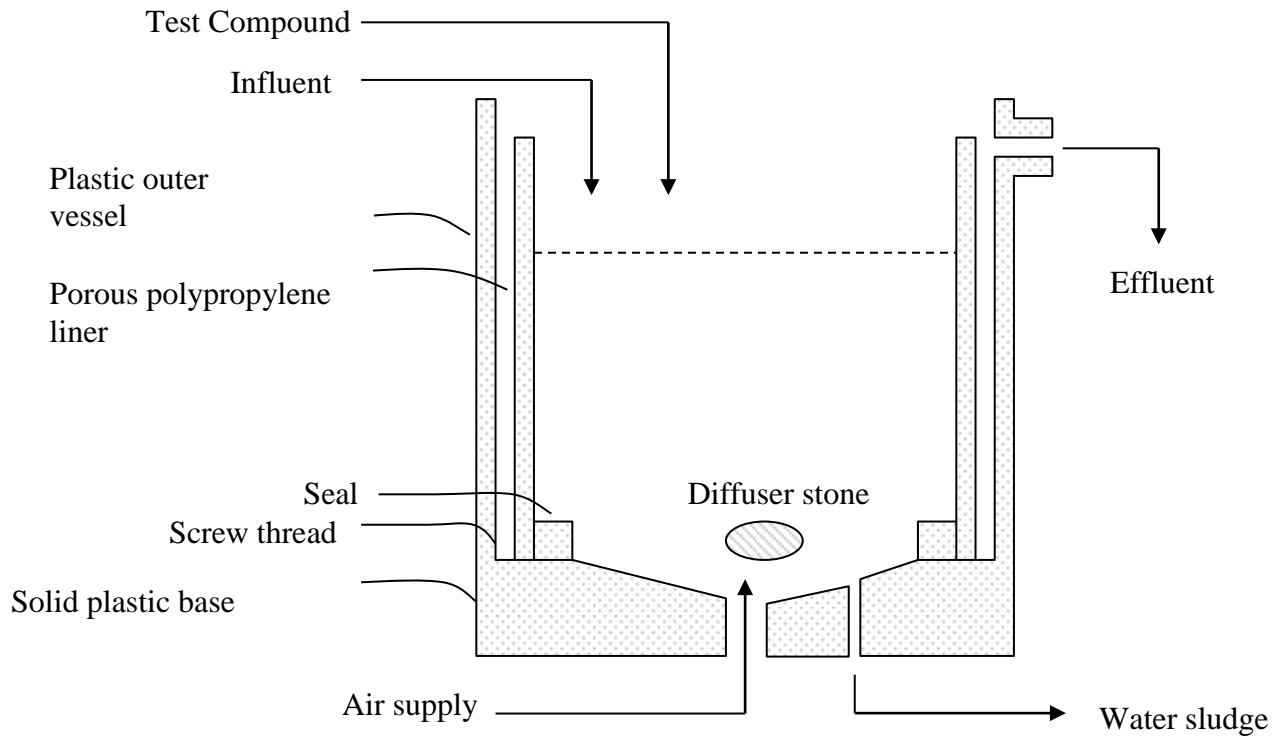

Appendix 2Calculation of Kinetic Constants

1. By assuming Monod kinetics apply and considering a mass balance of active solids and substrate across the activated sludge system (1), the following steady state expressions can be obtained:

$$\frac{1}{\theta_s} = \frac{\mu_m \cdot S_1}{K_s + S_1} - K_d \quad [1]$$

or

$$S_1 = \frac{K_s \cdot (1 + K_d \cdot \theta_s)}{\theta_s \cdot (\mu_m - K_d) - 1} \quad [2]$$

where S_1 = concentration of substrate in effluent, (mg/l)
 K_s = half-saturation constant, the concentration at which $\mu = \mu_m/2$ (mg/l)
 μ = specific growth rate (d^{-1})
 μ_m = maximum value of μ (d^{-1})
 K_d = specific decay rate of active solids (d^{-1})
 θ_s = sludge mean retention time, SRT (d)

Examination of this equation leads to the following conclusions:

- (i) The effluent concentration is independent of that in the influent (S_0); hence, the percentage biodegradation varies with the influent concentration, S_0 .
- (ii) The only plant-control parameter affecting S_1 is the sludge retention time, θ_s .
- (iii) For a given concentration in the influent, S_0 , there will be a critical sludge retention time, such that:

$$\frac{1}{\theta_{sc}} = \frac{\mu_m \cdot S_0}{K_s + S_0} - K_d \quad [3]$$

where θ_{sc} = critical sludge retention time, below which the competent micro-organisms will be washed out of the plant.

- (iv) Since the other parameters in equation (2) are associated with growth kinetics, temperature is likely to affect the effluent substrate level and the critical sludge age, ie. the sludge retention time needed to obtain a certain degree of treatment would increase with decreasing temperature.

2. From a mass balance of solids in the porous pot system, and assuming that the solids concentration in the plant effluent, X_2 is low compared with that in the aeration vessel, X_1 , the sludge retention time

$$\theta_s = \frac{V \cdot X_1}{(Q_0 - Q_1) \cdot X_2 + Q_1 \cdot X_1} \quad [4]$$

and

$$\theta_s = \frac{V \cdot X_1}{Q_1 \cdot X_1} = \frac{V}{Q_1}$$

where V = volume of the aeration vessel (l)

X_1 = concentration of solids in aeration vessel (mg/l)

X_2 = concentration of solids in effluent (mg/l)

Q_0 = flow rate of influent (l/d)

Q_1 = flow rate of waste sludge (l/d)

Thus, it is possible to control the sludge retention time at any pre-selected value by the control of the waste sludge flow rate, Q_1 .

Conclusions

3. The main purpose of the test is thus to allow the effluent concentration, and hence the levels of test substance in the receiving waters, to be predicted.

4. By plotting S_1 , vs. θ_s , the critical sludge retention time, θ_{SC} , can sometimes be readily evaluated, eg. curve 3 in Figure 1. When this is not possible, θ_{SC} may be calculated, together with approximate values of μ_m and K_s , by plotting S_1 , vs. $S_1 \cdot \theta_s$.

Rearrangement of equation (1) gives

$$\frac{S_1 \cdot \theta_s}{1 + \theta_s \cdot K_d} = \frac{K_s}{\mu_m} + \frac{S_1}{\mu_m} \quad [5]$$

If K_d is small, then $1 + \theta_s \cdot K_d \sim 1$ and [5] becomes:

$$S_1 \cdot \theta_s = \frac{K_s}{\mu_m} + \frac{S_1}{\mu_m} \quad [6]$$

Thus, the plot should be a straight line (see Figure 2) of slope $1/\mu_m$ and intercept K_s/μ_m ; also $\theta_s \sim 1/\mu_m$.

Figure 1: Three temperatures; Five SRTs

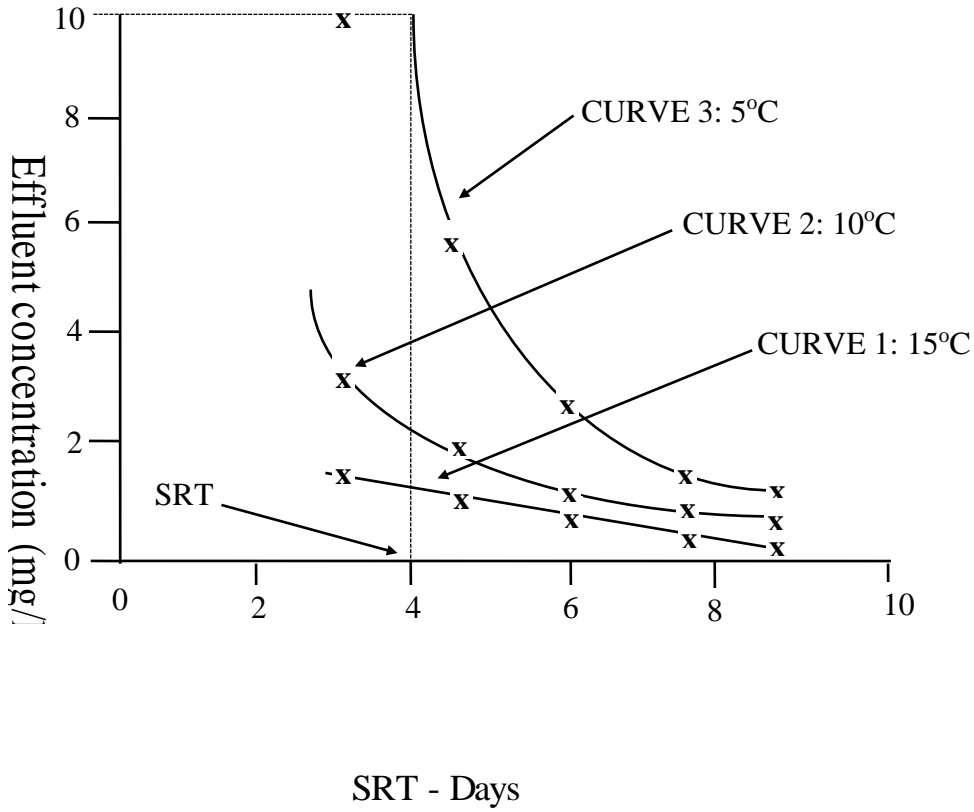
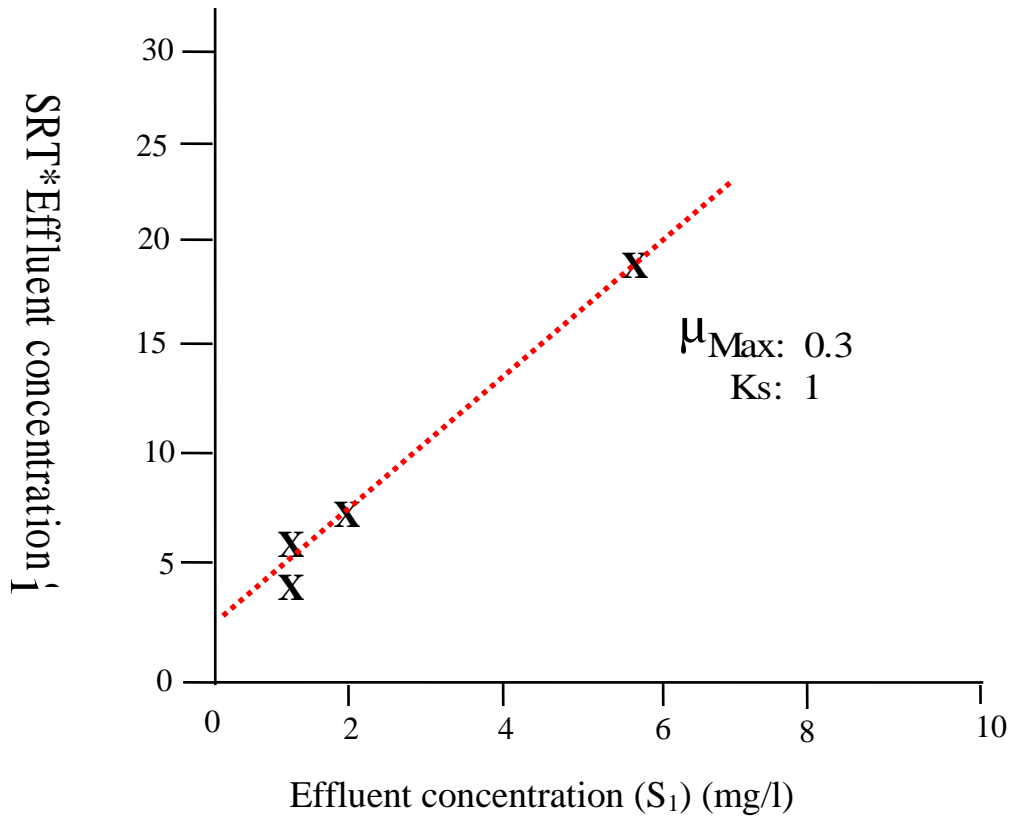

Figure 2: Regression Line $SRT \cdot S_1$ vs S_1 at $T = 5^\circ C$



ANNEX 7**TEST AT LOW ($\mu\text{g/l}$) CONCENTRATION RANGE**

1. Many chemicals are normally present in the aquatic environment, even in waste waters, at very low concentrations ($\mu\text{g/l}$). At such concentrations, they probably do not serve as primary substrates resulting in growth, but are more likely to degrade as non-growth, secondary substrates, concurrent with a variety of naturally occurring carbon compounds. Consequently the degradations of such chemicals will not fit the model described in Annex 6. There are many models which could be applied and, under the conditions prevailing in waste water treatment systems, more than one may be simultaneously operative. Far more research will be necessary to elucidate this problem.

2. Meanwhile the procedure given in the main text (303A) can be followed, but only for primary biodegradability, using suitably low concentrations ($<100 \mu\text{g/l}$) and a validated analytical procedure. The percentage biodegradation may be calculated (see para. 54 of the guideline) provided that abiotic processes (adsorption, volatility, etc.) are taken into account. An example is the study by Nyholm and his associates (1)(2) using a 4 h cycle in a fill and draw system. They reported pseudo first-order constants for 5 chemicals added in a synthetic sewage at 5 to $100 \mu\text{g/l}$. (For ultimate biodegradability ^{14}C -labelled test substances may be used. A description of this is beyond the scope of this Guideline since there are as yet no agreed procedures, though a proposed method for ISO standard 14592 (3) contains guidance on the use of ^{14}C -labelled substances.

SCAS test

3. Later, a simpler two-stage test was proposed (4)(5)(6); the semi-continuous activated sludge (SCAS) method is followed by short-term kinetic tests on samples withdrawn from the SCAS units. The SCAS system is operated with known sludge wastage rates (unlike the original 302 A method) and is fed a modified OECD synthetic sewage or domestic sewage. The synthetic sewage was modified (because of changing pH value and poor sludge settleability) by addition of phosphate as buffer, yeast extract, iron (III) chloride and trace element salts, and its COD was increased to about 750 mg/l by increasing the concentration of peptone and meat extract. The units were operated on a 24 h cycle: aeration for 23 h, wastage of sludge, settlement, withdrawal of supernatant (effluent) followed by addition of synthetic sewage plus test substance, up to $100 \mu\text{g/l}$, (i.e. at about the same concentration used in the short term test). Once per week 10% of the total sludge was replaced by fresh sludge in order to maintain a balanced microbial population.

4. The concentrations of test substance initially and at the end of aeration are measured and the test is continued until a constant removal of test substance is attained; this takes from one week to several months.

Short-term test

5. A short test (e.g. 8 hours) is applied to determine the (pseudo) first order kinetic rate constant for the decay of the test substance in activated sludge of known but different origins and histories. In particular, sludge samples are taken from the SCAS reactors - at the end of an aeration period when the concentration of organic substrate is low - during the course of an acclimatisation experiment (paragraphs 3, 4). Sludge may also be taken from a parallel SCAS unit not exposed to the test substance, for comparison. Mixtures of sludge and the test substance added at two or more concentrations in the range $1\text{-}50 \mu\text{g/l}$ are aerated, without the

addition of synthetic sewage or other organic substrate. The test substance remaining in solution is determined at regular intervals e.g. hourly depending on the degradability of the substance, for a period not longer than 24h. Samples are centrifuged before appropriate analysis.

Calculations

6. Data from the SCAS units are used to calculate the percentage removal of test substance (paragraph 54). Also, an average rate constant, K_1 , (normalised for concentration of suspended solids) can be calculated from:

$$K_1 = 1/t \cdot \ln \frac{C_e}{C_i} \cdot 1/SS \text{ (l/g h)}$$

where t = aeration time (23h)
 C_e = concentration at end of aeration period ($\mu\text{g/l}$)
 C_i = concentration at beginning of aeration ($\mu\text{g/l}$)
 SS = concentration of activated sludge solids (g/l)

7. In the short term test the log.% concentration remaining is plotted against time and the slope of the initial part (10-50% degradation) of the plot is equivalent to K_1 , the (pseudo) first order constant. The constant is normalised with respect to the concentration of sludge solids by dividing the slope by the concentration of sludge solids. The reported result must also include details of initial concentrations of the test substance and suspended solids, sludge retention time, sludge loading and source, and details of pre-exposure (if any) to the test substance.

Variability of results

8. Variability and other facets of biodegradation kinetics were discussed at a recent SETAC workshop (7). From such studies, reported and projected, a clearer view of kinetics operating in waste water treatment plants should be forth-coming to enable a better interpretation of existing data to be made, as well as to suggest more relevant designs for future test guidelines.

References

- (1) Nyholm, N. Jacobsen, BN. Pedersen, BM. Poulsen, O. Dambourg, A. and Schultz, B. (1992) Removal of micropollutants in laboratory activated sludge reactors. Biodegradability. *Wat. Res.*, 26, 339-353.
- (2) Jacobsen, BN. Nyholm, N. Pedersen, BM. Poulsen O, and Ostfeldt, P. (1993). Removal of organic micropollutants in laboratory activated sludge reactors under various operating conditions: Sorption. *Wat. Res.*, 27, 1505-1510.
- (3) ISO 14592 (ISO/TC 147/ SC5/ WG4, N264) (1998). Water Quality - Evaluation of the aerobic biodegradability of organic compounds at low concentrations in water.

- (4) Nyholm, N. Ingerslev, F. Berg, UT. Pedersen, JP and Frimer-Larsen H. (1996) Estimation of kinetic rate constants for biodegradation of chemicals in activated sludge waste water treatment plants using short-term batch experiments and $\mu\text{g/l}$ range spiked concentrations *Chemosphere* 33 (5) 851-864.
- (5) Berg U.T. and Nyholm, N. (1996). Biodegradability simulation Studies in semi-continuous activated sludge reactors with low ($\mu\text{g/l}$ range) and standard (ppm range) chemical concentrations. *Chemosphere* 33 (4) 711-735.
- (6) Danish Environmental Protection Agency. (1996). Activated sludge biodegradability simulation test. Environmental Project, No. 337. Nyholm, N. Berg, UT. Ingerslev, F. Min. of Env. and Energy, Copenhagen.
- (7) Biodegradation kinetics: Generation and use of data for regulatory decision making (1997). Workshop at Port Sunlight, UK. Eds. Hales, SG. Feitjel, T. King, H. Fox, K. and Verstraete, W. 4-6th Sept. 1996. SETAC- Europe, Brussels.

303 B: Biofilms**INTRODUCTION**

1. Simulation tests are normally applied to chemicals which have failed a screening test for ready biodegradability (301 A to F), but have passed a test for inherent biodegradability. Exceptionally simulation tests are also applied to any substance about which more information is required, especially high-tonnage chemicals, and normally the activated sludge test is applied (303 A). In some circumstances, however, specific information is required relating the behaviour of a chemical to methods of waste water treatment involving biofilms, namely, percolating or trickling filters, rotating biological contactors, fluidised beds. To meet this need various devices have been developed.

2. Gerike et al (1) used large, pilot-scale trickling filters which they used in the coupled mode. These filters took up much space and required relatively large volumes of sewage or synthetic sewage. Truesdale et al (2) described smaller filters (6 ft x 6 in. diameter) which were fed surfactant-free natural sewage but still required rather large volumes. As many as 14 weeks were required for the development of a "mature" biofilm and an additional 4-8 weeks were needed after first introduction of the test surfactant before acclimatisation took place.

3. Baumann et al (3) developed a much smaller filter which used polyester "fleece" previously steeped in activated sludge as the inert medium supporting the biofilm. The test substance was used as the sole source of carbon and biodegradability was assessed from measurements of dissolved organic carbon (DOC) in the influent and effluent, and from the amount of CO₂ in the exit gas.

4. A quite different approach was made by Gloyna et al (4) who invented the rotating tubular reactor. On the internal surface of the rotating tube a biofilm was grown on the known surface area by passage of influent introduced at the top end of the tube, inclined at a small angle to the horizontal. The reactor has been used to study the biodegradability of surfactants (5), as well as to investigate the optimal thickness of biofilm and diffusion through the film (6). These latter authors further developed the reactor, including modifying it to be able to determine CO₂ in the exit gas.

5. The rotating tubular reactor has been adopted by the Standing Committee of Analysts (UK) as a standard method for assessing both the biodegradability of chemicals (7) and the treatability and toxicity of waste waters (8). The method described here has the advantages of simplicity, compactness, reproducibility and the need for relatively small volumes of organic medium.

PRINCIPLE OF THE TEST

6. Synthetic or domestic sewage, and the test substance, in admixture or alone, are applied to the internal surface of a slowly rotating inclined tube. A layer of microorganisms, similar to those present on bio-filter media, is built up on the internal surface. The conditions of operation of the reactor are chosen to give adequate elimination of organic matter and, if required, oxidation of ammonium.

7. Effluent from the tube is collected and either settled and/or filtered before analysis for dissolved organic carbon (DOC) and/or the test substance by a specific method. Control units receiving no test substance are operated in parallel under the same conditions for comparative purposes. The difference between the concentrations of DOC in the effluent from the test and control units is assumed to be due to the test substance and its organic metabolites. This difference is compared with the concentration of the added test substance (as DOC) to calculate the elimination of the test substance.

8. Biodegradation may normally be distinguished from bio-adsorption by careful examination of the elimination-time curve. Confirmation may usually be obtained by applying a test for ready biodegradation (oxygen uptake or carbon dioxide production) using an acclimated inoculum taken at the end of the test from the reactors receiving the test substance.

INFORMATION ON THE TEST SUBSTANCE

9. The purity, water solubility, volatile and adsorption characteristics of the test substance should be known to enable correct interpretation of results to be made.

10. Normally, volatile and poorly soluble substances cannot be tested unless special precautions are taken (see Annex 5, 303 A). The chemical structure, or at least the empirical formula, should also be known in order to calculate theoretical values and/or to check measured values of parameters, e.g. theoretical oxygen demand (ThOD), DOC.

11. Information on the toxicity of the test substance to micro-organisms (see Annex 4, 303 A) may be useful for selecting appropriate test concentrations and may be essential for the correct interpretation of low biodegradation values.

PASS LEVELS

12. Originally, the primary biodegradation of surfactants was required to reach 80% or more before the substance could be marketed. If the value of 80% is not attained, this simulation (confirmatory) test may be applied and the surfactant may be marketed only if more than 90% of the specific substance is removed. With chemicals in general there is no question of a pass/fail level and the value of percentage removed can be used in proximate calculations of the probable environmental concentration to be used in hazard assessments posed by chemicals. In a number of studies of pure chemicals the percentage removal of DOC was found to be >90% in more than three-quarters, and >80% in over 90%, of chemicals which showed any significant degree of biodegradability.

REFERENCE SUBSTANCES

13. To ensure that the experimental procedure is being carried out correctly, it is useful occasionally to test reference compounds whose behaviour is known. Such compounds include adipic acid, 2-phenyl phenol, 1-naphthol, diphenic acid and 1-naphthoic acid.

REPRODUCIBILITY OF TEST RESULTS

14. The relative standard deviation within tests was found by a laboratory in the UK to be 3.5% and between tests to be 5% (7).

DESCRIPTION OF THE METHOD

Apparatus

Rotating tubular reactors

15. The apparatus (see figures 1 and 2 in the Annex) consists of a bank of acrylic tubes each 30.5 cm long and 5 cm internal diameter, supported on rubber-rimmed wheels contained within a metal supporting frame. Each tube has an outside lip, approximately 0.5 cm deep, to retain it on the wheels, the internal surface is roughened with coarse wire wool and there is a 0.5 cm deep internal lip at the upper (feed) end to retain the liquid. The tubes are inclined at an angle of approximately one degree to the horizontal to achieve the required contact time when the test medium is applied to a clean tube. The rubber-tyred wheels are rotated using a slow, variable-speed motor. The temperature of the tubes is controlled by installation in a constant temperature room.

16. By enclosing each tube reactor inside a slightly larger, capped tube and ensuring that connections were gas-tight, exit CO₂ gas could be collected in an alkaline solution for subsequent measurement (6).

17. A 24h supply, for each tube, of organic medium with added test substance if applicable, is contained in a 20 l storage vessel (A)(see Figure 2). If required, the test substance solution may be dosed separately. Near the bottom of each storage vessel there is an outlet which is connected by suitable tubing, e.g. silicone rubber, via a peristaltic pump (B) to a glass or acrylic delivery tube which enters 2-4 cm into the higher (feed) end of the inclined tube (C). Effluent is allowed to drip from the lower end of the inclined tube to be collected in another storage vessel (D). The effluent is settled or filtered before analysis.

Filtration apparatus-centrifuge

18. Device for filtration of samples with membranes filter of suitable porosity (nominal aperture diameter 0.45 µm) which adsorb organic compounds or release organic carbon to a minimum degree. If filters are used which release organic carbon, wash them carefully with hot water to remove leachable organic carbon. Alternatively a centrifuge capable of achieving 40,000 m/sec² may be used.

19. Analytical equipment for determining:

- DOC/total organic carbon (TOC), or chemical oxygen demand (COD);
- specific substance (HPLC, GC etc.) if required;
- pH, temperature, acidity, alkalinity;
- ammonium, nitrite, nitrate, if the tests are performed under nitrifying conditions.

Water

20. Tap water, containing less than 3 mg/l DOC.

21. Distilled or deionised water, containing less than 2 mg/l DOC.

Organic medium

22. Synthetic sewage, domestic sewage or a mixture of both may be used as the organic medium. It has been shown that the use of domestic sewage alone often gives increased percentage removed of DOC (in activated sludge units) and even allows the biodegradation of some chemicals which are not biodegraded when OECD synthetic sewage is used. Thus, the use of domestic sewage is recommended. Measure the DOC (or COD) concentration in each new batch of organic medium. The acidity or alkalinity of the organic medium should be known. The medium may require the addition of a suitable buffer (sodium hydrogen carbonate or potassium hydrogen phosphate), if it is of low acidity or alkalinity, to maintain a pH of about 7.5 ± 0.5 in the reactor during the test. The amount of buffer, and when to add it, has to be decided in each individual case.

Synthetic sewage

23. Dissolve in each 1 litre of tap water: peptone, 160 mg; meat extract, 110 mg; urea, 30 mg; anhydrous dipotassium hydrogen phosphate, (KH_2PO_4), 28 mg; sodium chloride, (NaCl), 7 mg; calcium chloride dihydrate, ($\text{CaCl}_2 \cdot 2\text{H}_2\text{O}$), 4 mg; magnesium sulphate heptahydrate, ($\text{MgSO}_4 \cdot 7\text{H}_2\text{O}$), 2 mg. This OECD synthetic sewage is an example and gives a mean DOC concentration in the influent of about 100 mg/l. Alternatively, use other compositions, with about the same DOC concentrations, which are closer to real sewage. This synthetic sewage may be made up in distilled water in a concentrated form and stored at about 1 °C for up to one week. When needed, dilute with tap water. (This medium is unsatisfactory e.g. nitrogen concentration is very high, relatively low carbon content, but nothing better has been suggested, except to add more phosphate, as buffer, and extra peptone).

Domestic sewage

24. Use fresh settled sewage collected daily from a treatment works receiving predominantly domestic sewage. It should be collected from the overflow channel of the primary sedimentation tank, or from the feed to activated sludge plant, and be largely free from coarse particles. The sewage can be used after storage for several days at about 4 °C, if it is proved that the DOC (or COD) has not significantly decreased (i.e. by less than 20%) during storage. In order to limit disturbances to the system, the DOC (or COD) of each new batch should be adjusted before use to an appropriate constant value, e.g. by dilution with tap water.

Lubricant

25. Glycerol or olive oil may be used for lubricating the peristaltic pump rollers: both are suitable for use on silicone-rubber tubing.

Stocks solutions of test substance

26. For substances of adequate solubility prepare stock solutions at appropriate concentrations (e.g. 1 to 5 g/l) in deionised water or in the mineral portion of the synthetic sewage. For insoluble substances, see Annex 5 in guideline 303 A. This method is not suitable for volatile substances without modifications to the tubular reactors (paragraph 16). Determine the DOC and TOC of the stock solution and repeat the measurements for each new batch. If the difference between the DOC and TOC is greater than 20%, check the water-solubility of the test substance. Compare the DOC or the concentration of the test substance measured by specific analysis

of the stock solution with the nominal value to ascertain whether recovery is good enough (normally >90% can be expected). Ascertain, especially for dispersions, whether or not DOC can be used as an analytical parameter or if only an analytical technique specific for the test substance can be used. Centrifugation of the samples is required for dispersions. For each new batch, measure the DOC, COD or the test substance with specific analysis.

27. Determine the pH of the stock solution. Extreme values indicate that the addition of the substance may have an influence on the pH of the activated sludge in the test system. In this case neutralise the stock solution to obtain a pH of 7 ± 0.5 with small amounts of inorganic acid or base, but avoid precipitation of the test substance.

PROCEDURE

Preparation of organic medium for dosing

28. Ensure that all influent and effluent containers and tubing from influent vessels and to effluent vessels are thoroughly cleaned to remove microbial growths, initially and throughout the test.

29. Prepare the synthetic sewage (paragraph 23) freshly each day either from the solids or from the concentrated stock solution by appropriate dilution with tap water. Measure the required amount in a cylinder and add to a clean influent vessel. Also, where necessary, add the required amount of the stock solution of the test substance or reference substance to the synthetic sewage before dilution. If it is more convenient or necessary to avoid loss of the test substance, prepare a separate diluted solution of the test substance in a separate reservoir and deliver this to the inclined tubes via a different dosing pump.

30. Alternatively (and preferably), use settled domestic sewage (paragraph 24) collected freshly each day if possible.

Operation of rotating tubular reactors

31. Two identical tubular reactors are required for the assessment of one test substance, and they are assembled in a constant temperature room normally at 22 ± 2 °C.

32. Adjust the peristaltic pumps to deliver 250 ± 25 ml/h of the organic medium (without test substance) into the inclined tubes, which are rotated at 18 ± 2 rpm. Apply the lubricant (paragraph 25) to the pump tubes initially and periodically through the test to ensure proper functioning and to prolong the life of the tubing.

33. Adjust the angle of inclination of the tubes to the horizontal to produce a residence time of 125 ± 12.5 sec. for the feed in a clean tube. Estimate the retention time by adding a non-biological marker (e.g. NaCl, inert dye) to the feed: the time taken to reach peak concentration in the effluent is taken to be the mean retention time (when maximum film is present, the retention time can increase up to about 30 min.).

34. These rates, speeds and times have been found to give adequate removals (>80%) of DOC (or COD) and to produce nitrified effluents. The rate of flow should be changed if removal is insufficient or if the performance of a particular treatment plant is to be simulated. In the latter case, adjust the rate of dosing the organic medium until the performance of the reactor matches that of the treatment plant.

Inoculation

35. Airborne inoculation may be sufficient to start the growth of micro-organisms when synthetic sewage is used, but otherwise add 1 ml/l of settled sewage to the feed for 3 days.

Measurements

36. At regular intervals check that the dose-rates and rotating speeds are within the required limits. Also, measure the pH of the effluent, especially if nitrification is expected.

Sampling and analysis

37. The method, pattern and frequency of sampling are chosen to suit the purpose of the test. For example, take snap (or grab) samples of influent and effluent, or collect samples over a longer period e.g. 3-6 h. In the first period, without test substance, take samples twice per week. Filter the samples through membranes or centrifuge at about 40,000 m/sec² for about 15 min (paragraph 18). It may be necessary to settle and/or coarse-filter the samples before membrane filtration. Determine DOC (or COD) at least in duplicate and if required BOD, ammonium and nitrite/nitrate.

38. All analyses should be performed as soon as possible after collection and preparation of the samples. If analyses have to be postponed, store the samples at about 4°C in the dark in full, tightly stoppered bottles. If samples have to be stored for more than 48h, preserve them by deep-freezing, acidification or by addition of a suitable toxic substance (e.g. 20 ml/l of a 10 g/l solution of mercury (II) chloride). Ensure that the preservation technique does not influence the results of analysis.

Running-in period

39. In this period, the surface biofilm grows to reach an optimal thickness, usually taking about 2 weeks and should not exceed 6 weeks. The removal (paragraph 44) of DOC (or COD) increases and reaches a plateau value. When the plateau has been reached at a similar value in both tubes, one is selected to be a control in the remainder of the test, during which their performance should remain consistent.

Introduction of test substance

40. At this stage add the test substance to the other reactor at the required concentration, usually 10-20 mg C/l. The control continues to receive the organic medium alone.

Acclimation period

41. Continue the twice weekly analyses for DOC (or COD) and, if primary biodegradability is to be assessed, also measure the concentration of the test substance by specific analysis. Allow from one to six weeks (or longer under special conditions) after the test substance has first been introduced for acclimation to occur. When the percentage removal (paragraphs 43-45) reaches a maximum value, obtain 12-15 valid values in the plateau phase over about 3 weeks for evaluation of the mean percentage removal. The test is considered completed if a sufficiently high degree of elimination is reached. Normally, do not exceed a test duration of more than 12 weeks after the first addition of the test substance.

Sloughing of the film

42. The sudden removal of large quantities of excess film from the tubes, or sloughing, takes place at relatively regular intervals. To ensure that the comparability of results is unaffected, allow tests to cover at least two full cycles of growing and sloughing.

DATA AND REPORTING**Treatment of results**

43. Calculate the percentage DOC (or COD) elimination of the test substance for each timed assessment using the equation:

$$D_t = 100 [C_s - (E - E_o)] / C_s \%$$

where D_t = percentage elimination of DOC (or COD) at time t;
 C_s = concentration of DOC (or COD) in the influent due to the test substance, preferably estimated from the concentration in, and volume added, of the stock solution (mg/l);
 E = measured DOC (or COD) in the test effluent at time t (mg/l);
 E_o = measured DOC (or COD) in the control effluent at time t (mg/l).

Repeat the calculation for the reference substance, if tested.

Performance of the control reactor

44. The degree of DOC (or COD) elimination (D_B) of the organic medium in the control reactors is helpful information in assessing the biodegradative activity of the biofilm during the test. Calculate the percentage elimination from the equation:

$$D_B = 100 (1 - E_o/C_m) \%$$

where C_m = DOC (or COD) of the organic medium in the control influent (mg/l).

45. Calculate the removal (D_{ST}) of the test substance, if measured, by a specific analytical method at each time assessment from the equation:

$$D_{ST} = 100 (1 - S_e / S_i) \%$$

where S_i = measured or, preferably, estimated concentration of test substance in the test influent (mg/l)
 S_e = measured test substance concentration in the test effluent at time t (mg/l)

If the analytical method gives a positive value in unamended sewage equivalent to S_e mg/l, calculate the percentage removal (D_{SC}) from:

$$D_{SC} = 100 (S_i - S_e + S_e) / (S_i + S_e) \%$$

Expression of test results

46. Plot the percentage elimination D_t and D_{ST} (or D_{SC}), if available, versus time (see Annex 2 in 303 A). Take the mean (expressed to the nearest whole number) and standard deviation of the 12-15 values for D_T (and for D_{ST} , if available) obtained in the plateau phase as the percentage removal of the test substance. From the shape of the elimination curve, some conclusions may be drawn about the removal processes.

Adsorption

47. If a high DOC elimination of the test substance is observed at the beginning of the test, the test substance is probably eliminated by adsorption on to the biofilm. It may be possible to prove this by determining the adsorbed test substance on solids sloughed from the film. It is not usual for the elimination of the DOC of adsorbable substances to remain high throughout the test; normally, there is an initial high degree of removal which gradually falls to an equilibrium value. If, however, the adsorbed test substance was able to cause acclimation of the microbial population, the elimination of the test substance DOC would subsequently increase and reach a high, plateau level.

Lag phase

48. As in static, screening tests many test substances require a lag phase before full biodegradation occurs. In the lag phase, acclimation (or adaptation) of the competent bacteria takes place with almost no removal of the test substance; then the initial growth of these bacteria occurs. This phase ends and the degradation phase is arbitrarily taken to begin when about 10% of the initial amount of test substance is removed (after allowing for adsorption, if it occurs). The lag phase is often highly variable and poorly reproducible.

Plateau phase

49. The plateau phase of an elimination curve in a continuous test is defined as that phase in which the maximum degradation takes place. This phase should last at least 3 weeks and have about 12-15 measured valid values.

Mean degree of elimination of the test substance

50. Calculate the mean value from the elimination values D_t (and D_{st} , if available) of the test substance at the plateau phase. Rounded to the nearest whole number (1%), it is the degree of elimination of the test substance. It is also recommended to calculate the 95% confidence interval of the mean value. In a similar way calculate the mean degree (D_B) of elimination of the organic medium in the control vessel.

Indication of biodegradation

51. If the test substance does not adsorb significantly on to the biofilm and the elimination curve has a typical shape of a biodegradation curve with lag, degradation and plateau phases (paragraphs 48, 49), the measured elimination can safely be attributed to biodegradation. If a high initial removal has taken place, the simulation test cannot differentiate between biological and abiotic elimination processes. In such cases, and in other cases where there is any doubt about biodegradation (e.g. if stripping takes place), analyse adsorbed test substance on samples of the film or perform additional static (screening) tests for biodegradability based on parameters clearly indicating biological processes. Such tests are the oxygen uptake methods (301 C, 301 D

and 301 F) (9) or a test which measures CO₂ production (301 B or the Headspace method) (10); use as inoculum pre-exposed biofilm from the appropriate reactor.

52. If both the DOC removal and specific substance removal have been measured, significant differences (the former being lower than the latter) between the percentages removed indicate the presence in the effluents of intermediate organic products which may be more difficult to degrade; these should be investigated.

Validity of test results

53. Consider the test to be valid if the degree of DOC (or COD) elimination (D_B) in the control units is >80% after 2 weeks operation and no unusual observations have been made.

54. If a readily biodegradable (reference) substance has been tested, the degree of biodegradation should be >90% and the difference between duplicate values should not be greater than 5%. If these two criteria are not met, review the experimental procedures and/or obtain domestic sewage from another source.

55. Similarly, differences between biodegradation values from duplicate units (if used) treating a test substance should not differ by more than 5%. If this criterion is not met but the removals are high, continue analysis for a further three weeks. If removal is low, investigate the inhibitory effects of the test substance if not known and repeat the test at a lower concentration of test substance, if that is feasible.

Test Report

56. The test report must include the following:

Test substance:

- identification data;
- physical nature and, where relevant, physico-chemical properties.

Test conditions:

- any modifications to test system, especially if insolubles or volatiles tested;
- type of organic medium;
- proportion and nature of industrial wastes in sewage, if used and if known;
- method of inoculation;
- test substance stock solution - DOC (dissolved organic carbon) and TOC (total organic carbon) content; how prepared, if suspension; test concentration(s) used, reasons if outside range 10-20 mg/l DOC; method of addition; date first added; any changes in concentration;
- mean hydraulic retention time (with no growth); rotational speed of tube; approximate angle of inclination, if possible;
- details of sloughing; time and intensity;
- test temperature and range;
- analytical techniques employed.

Test results:

- all measured data DOC, COD, specific analyses, pH, temperature, N compounds, if relevant;

- all calculated date of D_t (or D_{tc}), D_B , D_s obtained in tabular form and elimination curves;
- information on lag and plateau phases, test duration, the degree of elimination of the test substance, of the reference substance (if tested) and of the organic medium (in the control unit), together with statistical data and statements of biodegradability and validity of the test;
- discussion of results.

LITERATURE

- (1) Gerike P, Fischer W, Holtmann W (1980). Biodegradability determinations in trickling filter units compared with the OECD Confirmatory Test. *Wat. Res.*, 14, 753-758.
- (2) Truesdale GA, Jones K, Vandyke KG (1959). Removal of synthetic detergents in sewage treatment processes: Trials of a new biologically attackable material. *Wat. Waste Tr. J.*, 7, 441-444.
- (3) Baumann U, Kuhn G and Benz M. (1998) Einfache Versuchsanordnung zur Gewinnung gewässerökologisch relevanter Daten, *UWSF - Z. Umweltchem. Ökotox.*, 10, 214-220.
- (4) Gloyna EF, Comstock RF, Renn CE (1952). Rotary tubes as experimental trickling filters. *Sewage ind. Waste*, 24, 1355-1357.
- (5) Kumke GW, Renn CE (1966). LAS removal across an institutional trickling filter. *JAOCS*, 43, 92-94.
- (6) Tomlinson TG, Snaddon DHM, (1966). Biological oxidation of sewage by films of micro-organisms. *Int.J. Air Wat. Pollut.*, 10, 865-881.
- (7) Her Majesty's Stationery Office (1982). Methods for the examination of waters and associated materials. Assessment of biodegradability, 1981, London.
- (8) Her Majesty's Stationery Office (1984). Methods for the examination of waters and associated materials. Methods for assessing the treatability of chemicals and industrial waste waters and their toxicity to sewage treatment processes, 1982, London.
- (9) OECD Guidelines for the Testing of Chemicals (1993). Ready Biodegradability 301 A-F.
- (10) ISO 14593 (1998) Water Quality-Evaluation in an aqueous medium of the ultimate biodegradability of organic compounds. Method by analysis of released inorganic carbon in sealed vessels. 14pp.

ANNEX
Figure 1: Rotating tubes

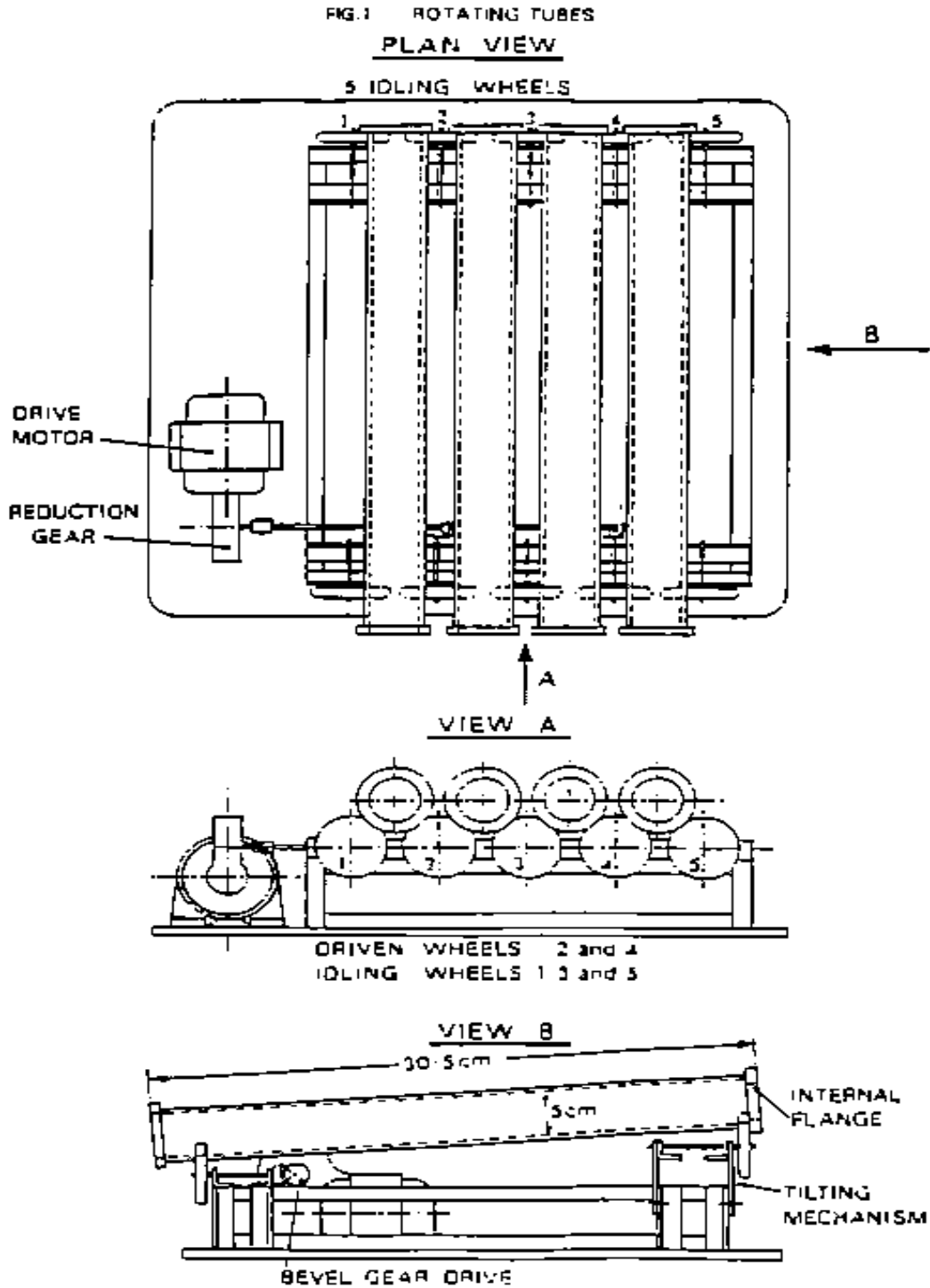
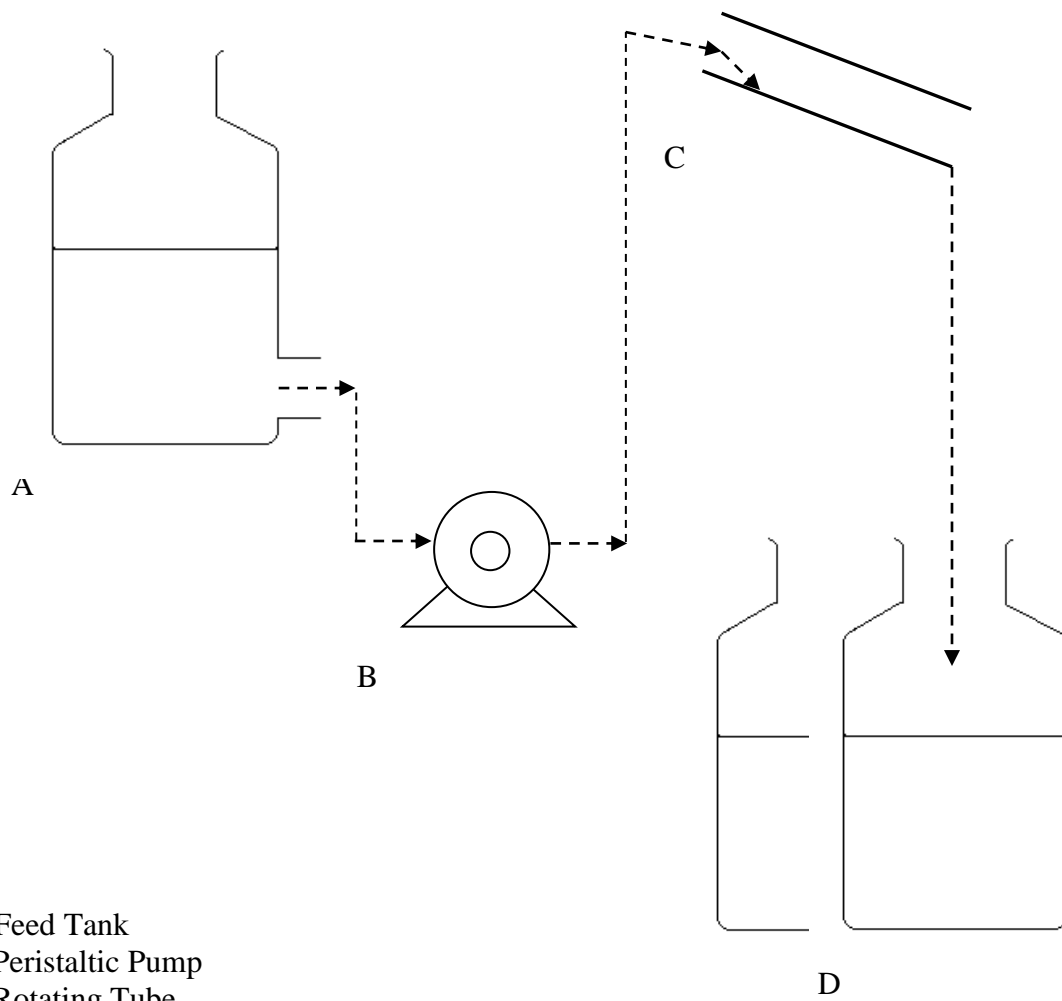

Figure 2**Flow diagram**

- A: Feed Tank
- B: Peristaltic Pump
- C: Rotating Tube
- D: Effluent Collection Vessel